

4

3

2

1

ITEM NO.	PART NUMBER	DESCRIPTION	QTY.
1	M09-10569	Ferris Z1 Hitch Mate Rect Tube	1
2	M09-10568	HITCH MATE FERRIS Z1 REAR SIDE BRACKET	1
3	M09-10567	HITCH MATE FERRIS Z1 REAR SIDE BRACKET	1
4	H09-10220	3/8-16 x 4.5" Long, Socket Head Screw	2
5	H09-10230	3/4" Dia 2" Long, Clevis Pin	2
6	HM-FLT-UNV	STANDARD FLAT HITCH RECEIVER	1
7	H09-10215	3/8-16 x 2.25" Carraige Bolt	4
8	H09-10008	3/8"-16 FLANGE LOCKNUT	4
9	H09-10231	1/8" Wire Cotter Pin (Hairpin) for 5/8" to 7/8" Clevis Pin Diameter	2

REVISIONS				
ZONE	REV.	DESCRIPTION	DATE	NAME
	A	ORIGINAL RELEASE	1/10/2022	JL

B

B

A

A



HITCH MATE MOUNT LOCATION

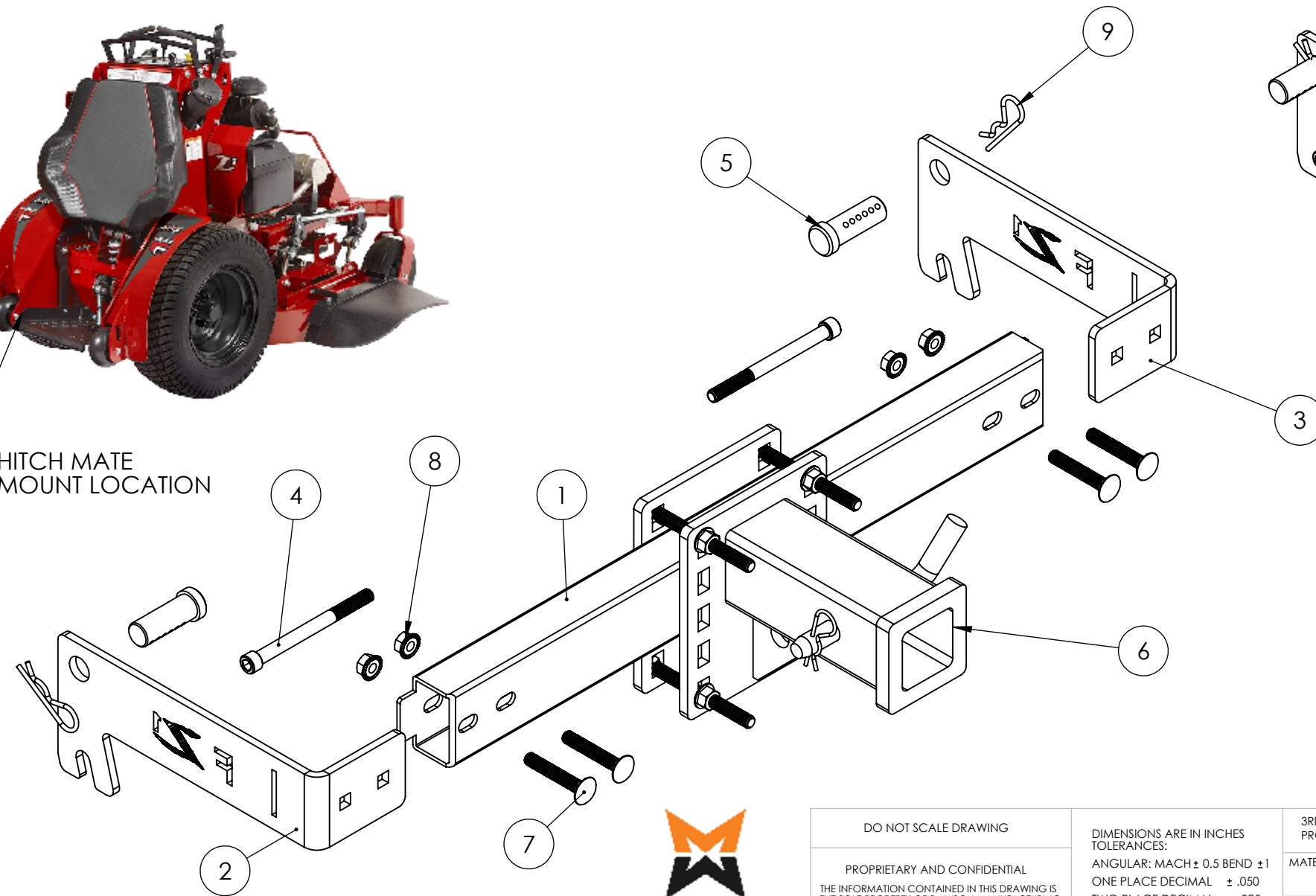
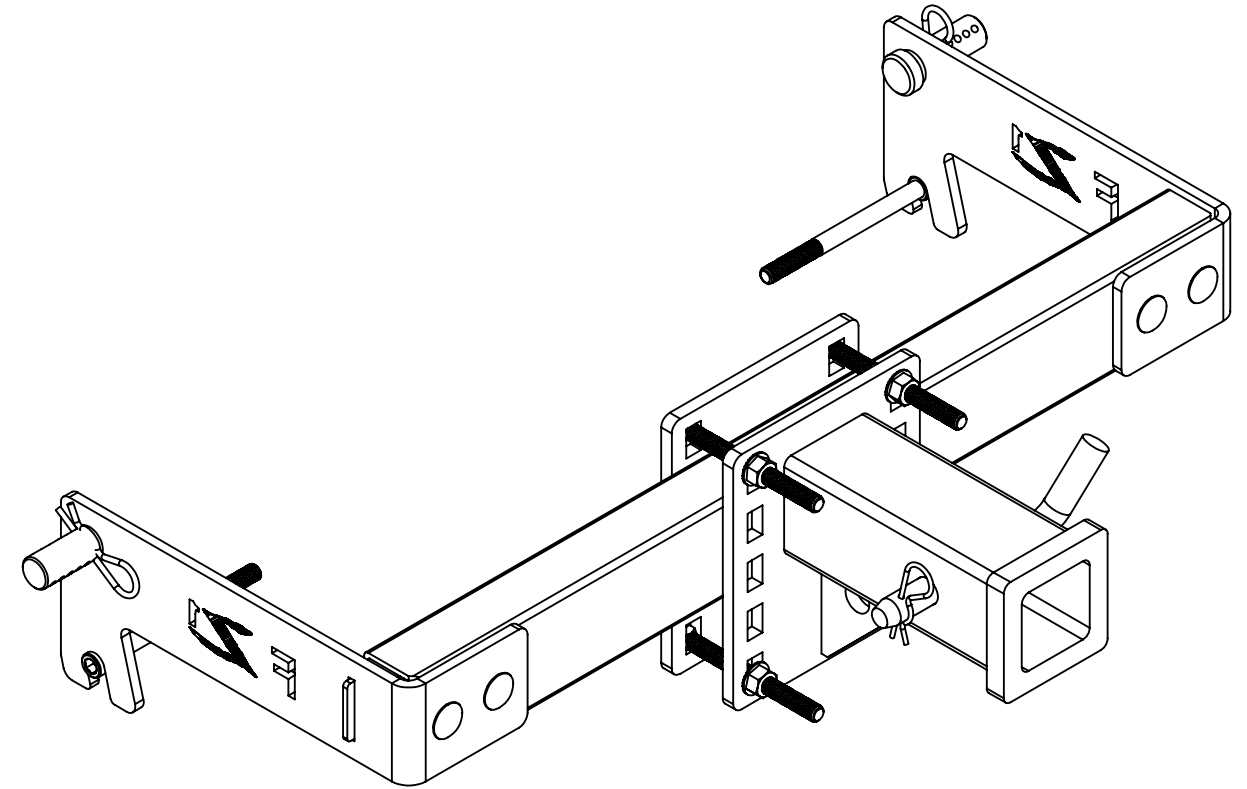

DO NOT SCALE DRAWING		3RD ANGLE PROJECTION		TITLE: HITCH MATE FERRIS Z1 REAR		PATENT PENDING	
PROPRIETARY AND CONFIDENTIAL THE INFORMATION CONTAINED IN THIS DRAWING IS THE SOLE PROPERTY OF DAWSON MANUFACTURING. ANY REPRODUCTION IN PART OR AS A WHOLE WITHOUT THE WRITTEN PERMISSION OF DAWSON MANUFACTURING IS PROHIBITED.		DIMENSIONS ARE IN INCHES TOLERANCES: ANGULAR: MACH ± 0.5 BEND ± 1 ONE PLACE DECIMAL ± .050 TWO PLACE DECIMAL ± .025 THREE PLACE DECIMAL ± .005		MATERIAL: SEE BOM		SCALE: 1:4	
				WEIGHT: 22.92 lbs		SHEET 1 OF 1	

4

3

2

1

SIZE	PART NO.	REV
B	HM-FER-Z1-R	A