

4

3

2

1

ITEM NO.	PART NUMBER	DESCRIPTION	QTY.
1	H09-10008	3/8"-16 FLANGE LOCKNUT	4
2	A09-10088	STANDARD FLAT HITCH RECEIVER	1
3	P09-10162	5/8" HITCH PIN AND COTTER PIN	1
4	H09-10223	3/8-16 x 4in CARRIAGE BOLT	4

REVISIONS				
ZONE	REV.	DESCRIPTION	DATE	NAME
	A	ORIGINAL RELEASE	5/8/2020	JL

*IF BOLTS STICK OUT MORE THAN 1/2" FROM NUT, IT IS RECOMMENDED TO CUT BOLT TO LENGTH

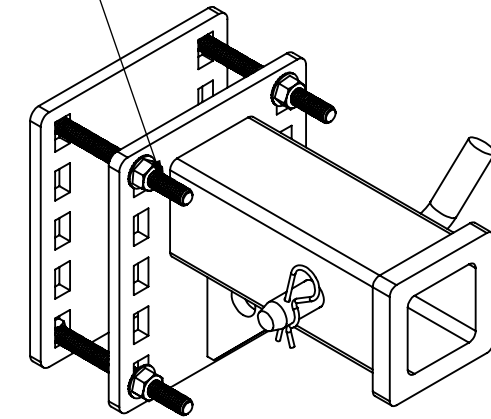
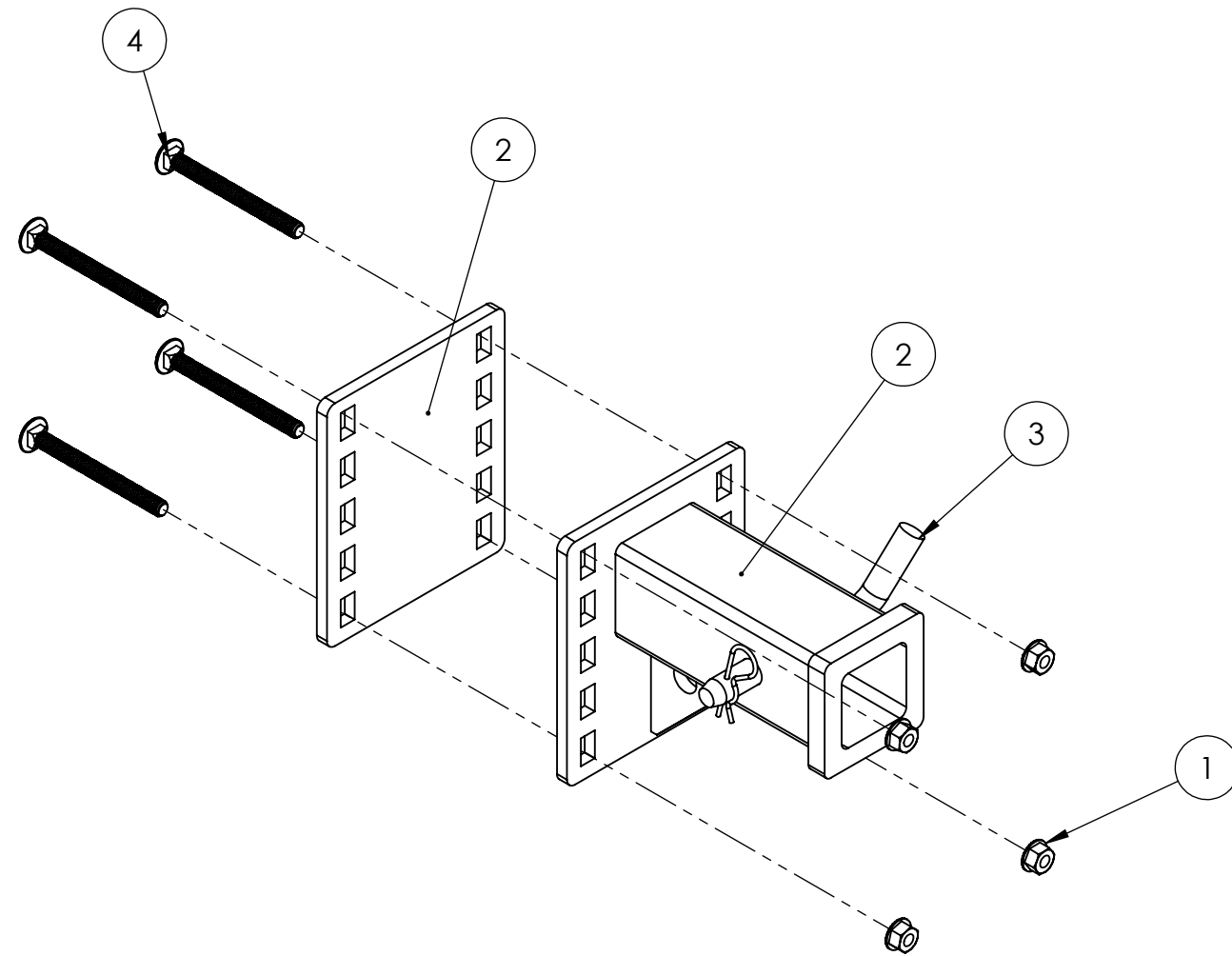

DO NOT SCALE DRAWING
 PROPRIETARY AND CONFIDENTIAL
 THE INFORMATION CONTAINED IN THIS DRAWING IS THE SOLE PROPERTY OF DAWSON MANUFACTURING. ANY REPRODUCTION IN PART OR AS A WHOLE WITHOUT THE WRITTEN PERMISSION OF DAWSON MANUFACTURING IS PROHIBITED.

DIMENSIONS ARE IN INCHES
 TOLERANCES:
 ANGULAR: MACH ± 0.5 BEND ± 1
 ONE PLACE DECIMAL ± .050
 TWO PLACE DECIMAL ± .025
 THREE PLACE DECIMAL ± .005

3RD ANGLE PROJECTION
 MATERIAL: SEE BOM
 FINISH

TITLE:
 STANDARD FLAT HITCH RECEIVER

PATENT PENDING
 SIZE: B PART NO.: HM-FLT-UNV REV: A
 SCALE: 1:4 WEIGHT: 11.47 lbs SHEET 1 OF 1

4

3

2

1

B

B

A

A