

4

3

2

1

ITEM NO.	PART NUMBER	DESCRIPTION	QTY.
1	HM-FLT-UNV	STANDARD FLAT HITCH RECEIVER	1
2	M09-10660	Hitch Mate JD/WRT Rear, Rect Tube	1
3	M09-10659	HITCH MATE SIDE SUPPORT, JOHN DEERE/WRIGHT, 661R/STX GEN 1	1
4	M09-10649	HITCH MATE SIDE SUPPORT, JOHN DEERE/WRIGHT, 661R/STX GEN 1	1
5	H09-10236	Clevis Pin 1" Diameter, 1-11/16" Usable Length	2
6	H09-10237	Cotter Pins 3/4" to 1-1/16" Clevis Pin Diameter, .172" Wire Diameter	2
7	H09-10215	3/8-16 x 2.25" Carriage Bolt	4
8	H09-10008	3/8"-16 FLANGE LOCKNUT	4

REVISIONS				
ZONE	REV.	DESCRIPTION	DATE	NAME
	A	ORIGINAL RELEASE	5/11/2021	JL



HITCH MATE  
MOUNT LOCATION

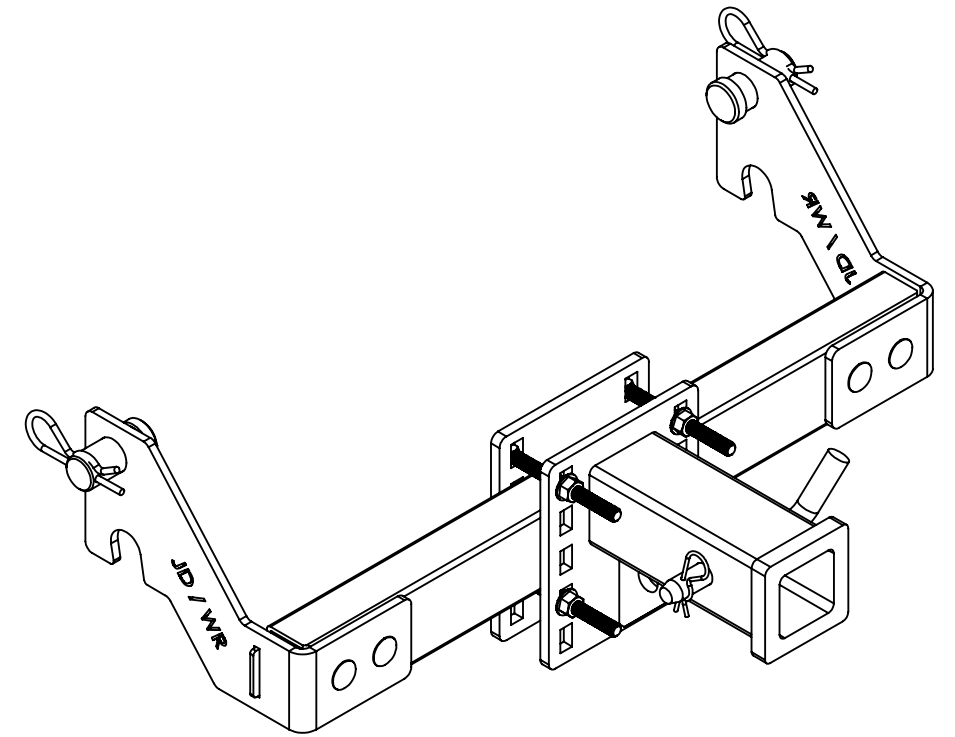
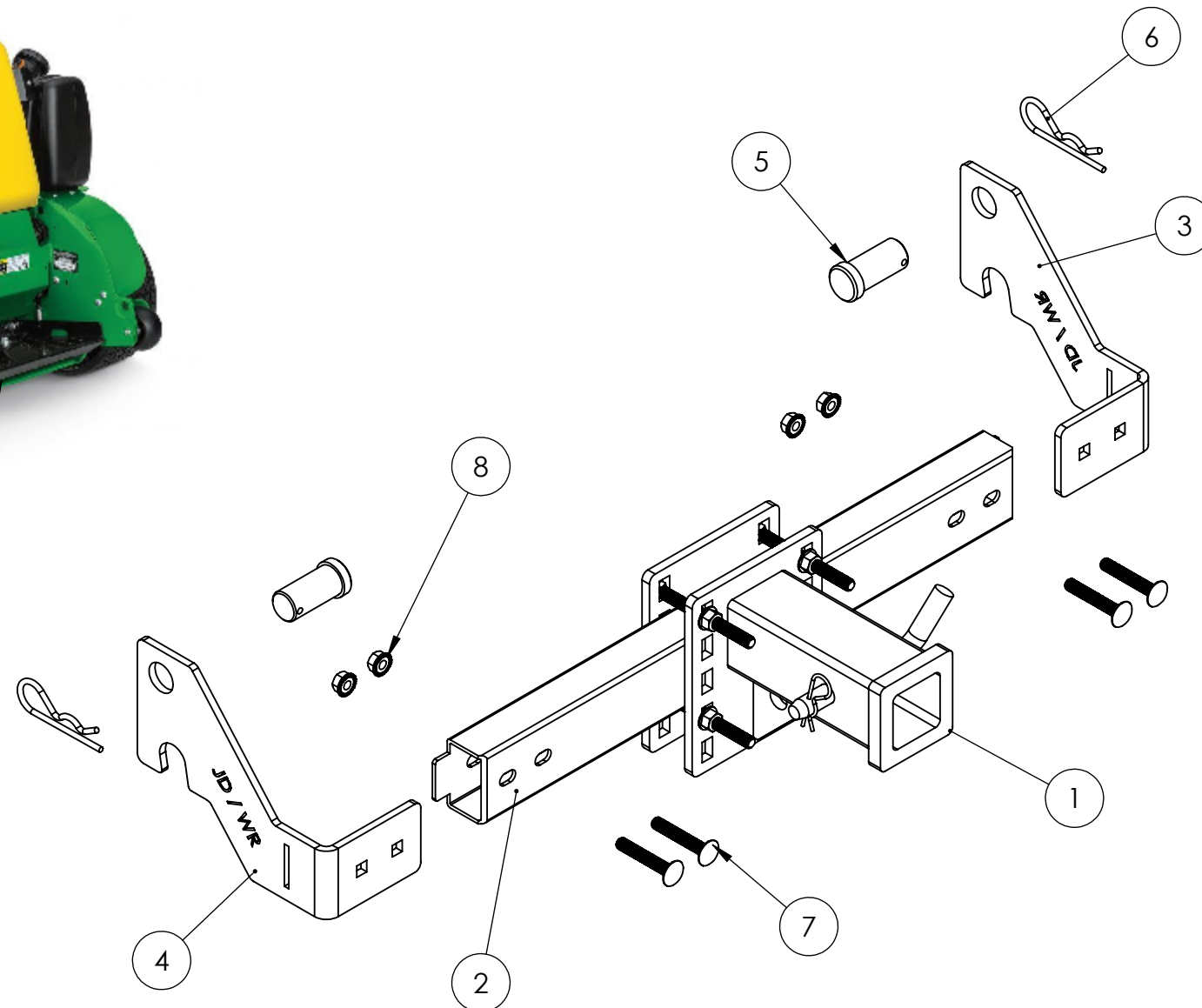

DO NOT SCALE DRAWING		3RD ANGLE PROJECTION		TITLE:	
PROPRIETARY AND CONFIDENTIAL		MATERIAL		HITCH MATE, JOHN DEERE, 661R, REAR	
THE INFORMATION CONTAINED IN THIS DRAWING IS THE SOLE PROPERTY OF DAWSON MANUFACTURING. ANY REPRODUCTION IN PART OR AS A WHOLE WITHOUT THE WRITTEN PERMISSION OF DAWSON MANUFACTURING IS PROHIBITED.		FINISH		SEE BOM	
DIMENSIONS ARE IN INCHES		PATENT PENDING		SCALE: 1:5 WEIGHT: 23.61 lbs SHEET 1 OF 1	
TOLERANCES:		SIZE		REV	
ANGULAR: MACH ± 0.5 BEND ± 1		B		A	
ONE PLACE DECIMAL ± .050		PART NO.		HM-JD-661R-R	
TWO PLACE DECIMAL ± .025					
THREE PLACE DECIMAL ± .005					

4

3

2

1

B

B

A

A