

MULCH MATE®

Truck Charging Harness Installation

- Disconnect all power before installing the wiring harness.
- Mount 12 volt solenoid in a safe location under the hood away from heat source or any possible hazard.
- Route wiring harness from the unit at the back of the truck toward the front of the truck being sure to avoid any heat source or any place the wire could get pinched or come in contact with moving parts of the truck. Secure with zip ties.
- Attach long red #2 cable to one side (A1) of the 12 volt solenoid
- Attach medium red #2 cable to the other side (A2) of the 12 volt solenoid.
- Attach the other side of the medium red #2 cable to the 125 amp fuse assembly.
- Attach short red #2 cable to the opposite side of the fuse assembly and then the other side to the positive (+) terminal of the battery.
- Attach the black #2 cable to the negative (-) terminal of the battery.
- Use #12 wire (not provided) to connect one side of the solenoid signal terminal (B2) to a switched 12 volt source. It is easiest to replace an existing switched 12V fuse with an "add-a-fuse". (see diagram →)
- Use #12 wire (not provided) to connect the other side of the solenoid signal terminal (B1) to ground.
- Test to be sure the Mulch Mate Connector only provides power when the truck is turned on. Otherwise the Mulch Mate could drain the truck's battery.

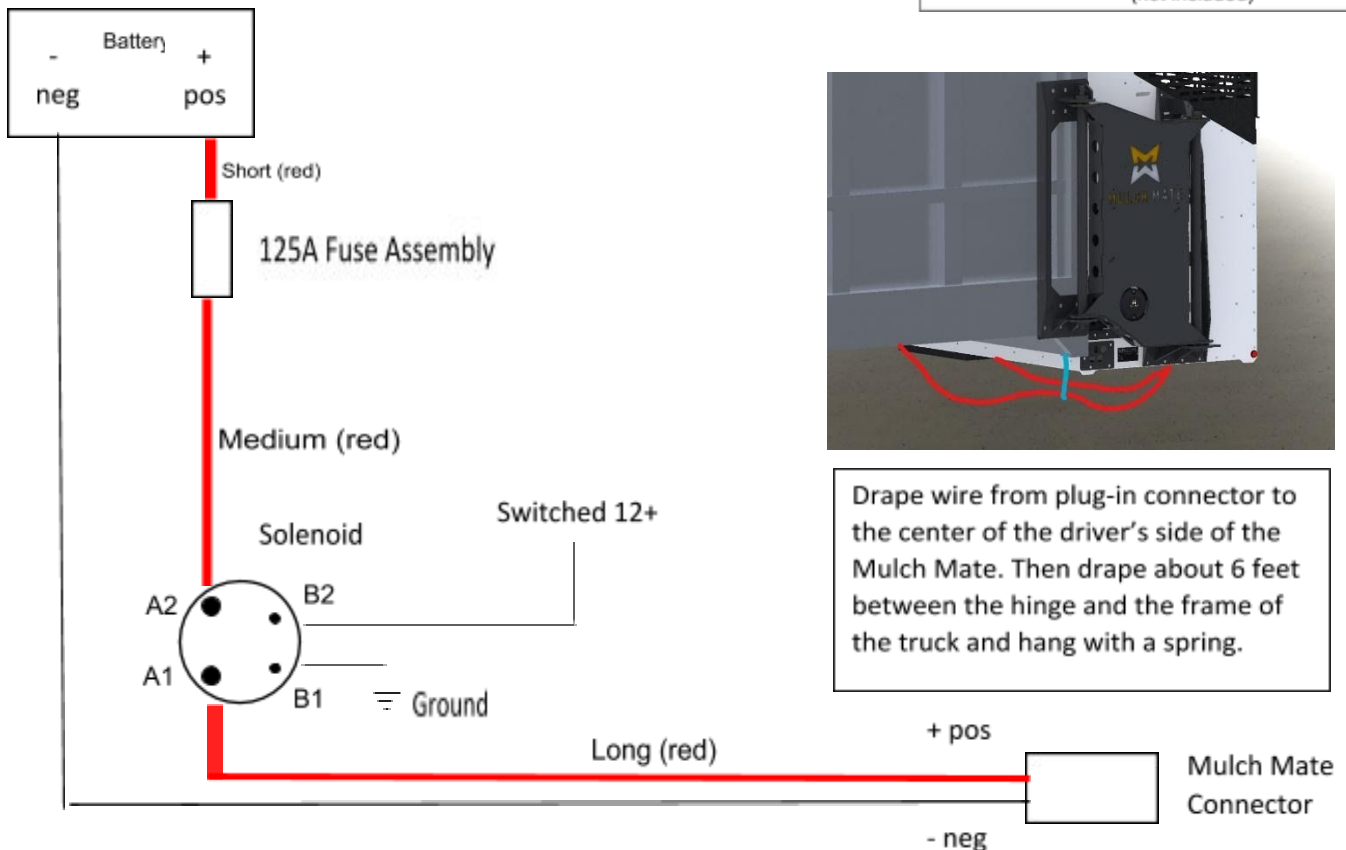
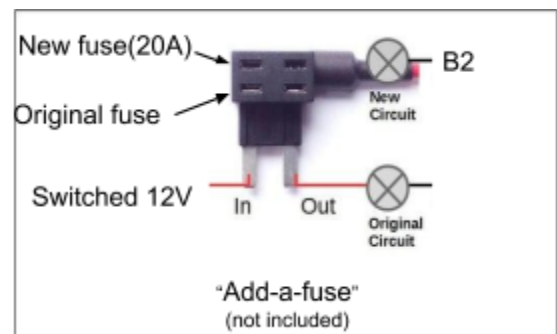

Dawson Manufacturing LLC

899 Airport Park Rd #E Glen Burnie, Md 21061 (888) 77MULCH www.MulchMateUSA.com