



# LED Linear High Bay

**Onward** ™  
TECH INC

## Product Appearance



*Light up your world with Onward .*

[www.onward-tech.com](http://www.onward-tech.com)

## Product Features

- 1. DLC5.1& FCC listed with LM79 & LM80
- 2. High luminous efficacy 160lm/w
- 3. High quality isolated driver, 0-10V dimming, Flicker free
- 4. PF > 0.95, driver efficiency > 88%, THD < 20%
- 5. Installation: hanging, it can add extra motion sensor or emergency battery.
- 6. Suitable for dry/damp location
- 7. Designed for warehouses, gymnasiums, and industrial spaces
- 8. CCT: 4000K & 4500K& 5000K& 5700K
- 9. Five years warranty

## Product Dimension

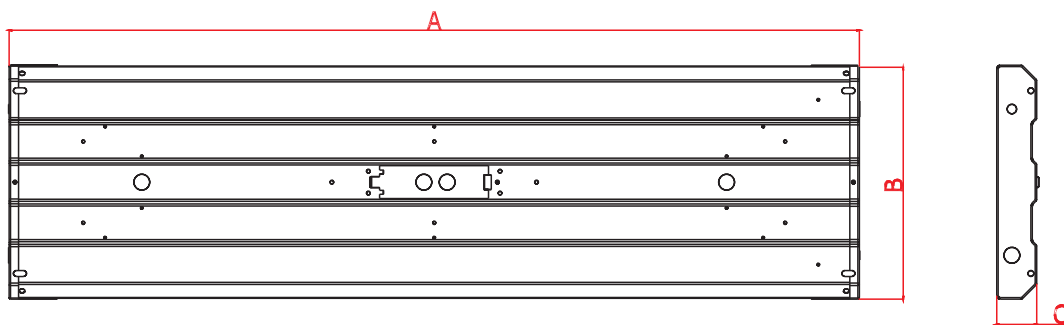

| Mode           | A<br>(inch)(mm) | B<br>(inch)(mm) | C<br>(inch)(mm) |
|----------------|-----------------|-----------------|-----------------|
| 2FTLHBA-80WLH  | 23.82"(605mm)   | 12.60"(320mm)   | 2.17"(55mm)     |
| 2FTLHBA-110WLH | 23.82"(605mm)   | 12.60"(320mm)   | 2.17"(55mm)     |
| 2FTLHBB-165WLH | 23.82"(605mm)   | 17.32"(440mm)   | 2.17"(55mm)     |
| 2FTLHBB-220WLH | 23.82"(605mm)   | 17.32"(440mm)   | 2.17"(55mm)     |
| 4FTLHBA-165WLH | 45.79"(1163mm)  | 12.60"(320mm)   | 2.17"(55mm)     |
| 4FTLHBA-225WLH | 45.79"(1163mm)  | 12.60"(320mm)   | 2.17"(55mm)     |
| 4FTLHBB-325WLH | 45.79"(1163mm)  | 17.32"(440mm)   | 2.17"(55mm)     |
| 2FTLHBA-110WHH | 23.82"(605mm)   | 12.60"(320mm)   | 2.17"(55mm)     |
| 2FTLHBB-165WHH | 23.82"(605mm)   | 17.32"(440mm)   | 2.17"(55mm)     |
| 2FTLHBB-220WHH | 23.82"(605mm)   | 17.32"(440mm)   | 2.17"(55mm)     |
| 4FTLHBA-225WHH | 45.79"(1163mm)  | 12.60"(320mm)   | 2.17"(55mm)     |
| 4FTLHBB-325WHH | 45.79"(1163mm)  | 17.32"(440mm)   | 2.17"(55mm)     |



## Specification

| Part No.       | Power | Input Voltage | Size | Input Current | PF    | Light Efficacy | Ra | CCT        |
|----------------|-------|---------------|------|---------------|-------|----------------|----|------------|
| 2FTLHBA-80WLH  | 80W   | AC120-277     | 2FT  | 0.8A          | >0.95 | 160lm/w        | 80 | 4000-5700K |
| 2FTLHBA-110WLH | 110W  | AC120-277     | 2FT  | 1.1A          | >0.95 | 160lm/w        | 80 | 4000-5700K |
| 2FTLHBB-165WLH | 165W  | AC120-277     | 2FT  | 1.65A         | >0.95 | 160lm/w        | 80 | 4000-5700K |
| 2FTLHBB-220WLH | 220W  | AC120-277     | 2FT  | 2.2A          | >0.95 | 160lm/w        | 80 | 4000-5700K |
| 4FTLHBA-165WLH | 165W  | AC120-277     | 2FT  | 1.65A         | >0.95 | 160lm/w        | 80 | 4000-5700K |
| 4FTLHBA-225WLH | 225W  | AC120-277     | 4FT  | 2.25A         | >0.95 | 160lm/w        | 80 | 4000-5700K |
| 4FTLHBB-325WLH | 325W  | AC120-277     | 4FT  | 3.25A         | >0.95 | 160lm/w        | 80 | 4000-5700K |
| 2FTLHBA-110WHH | 110W  | AC347-480     | 2FT  | 0.33A         | >0.95 | 160lm/w        | 80 | 4000-5700K |
| 2FTLHBB-165WHH | 165W  | AC347-480     | 2FT  | 0.5A          | >0.95 | 160lm/w        | 80 | 4000-5700K |
| 2FTLHBB-220WHH | 220W  | AC347-480     | 2FT  | 0.67A         | >0.95 | 160lm/w        | 80 | 4000-5700K |
| 4FTLHBA-225WHH | 225W  | AC347-480     | 4FT  | 0.68A         | >0.95 | 160lm/w        | 80 | 4000-5700K |
| 4FTLHBB-325WHH | 325W  | AC347-480     | 4FT  | 1.25A         | >0.95 | 160lm/w        | 80 | 4000-5700K |

## Testing Report

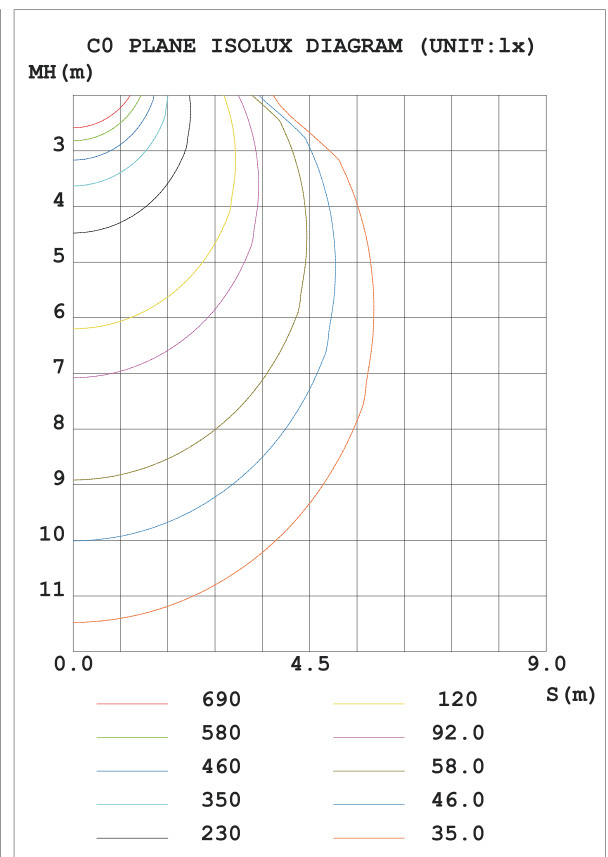
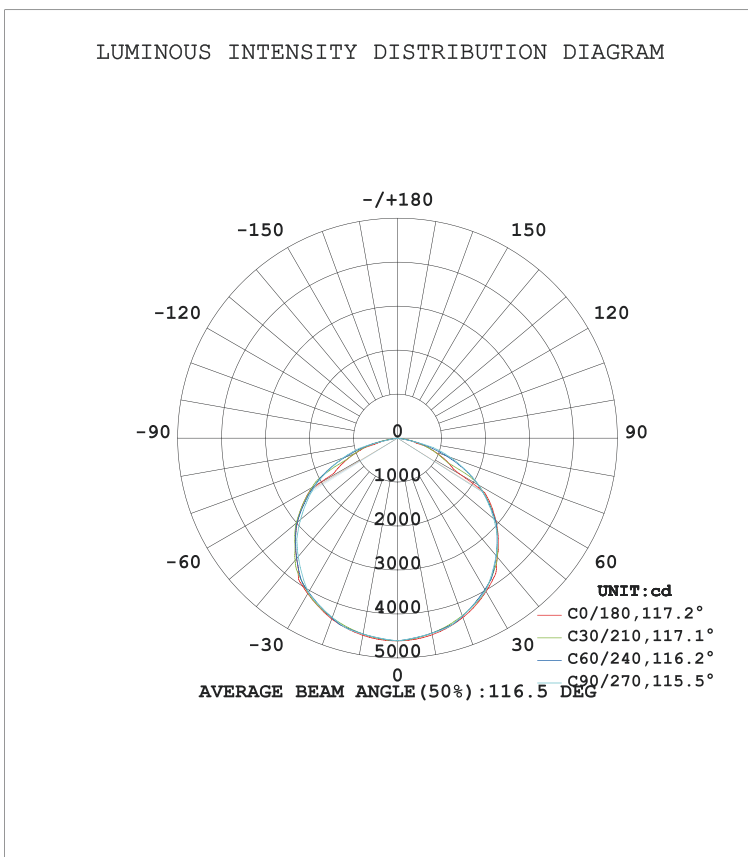



## Hanging installation instruction

Please turn off the power before installation

1. Hook the chain as below pic.

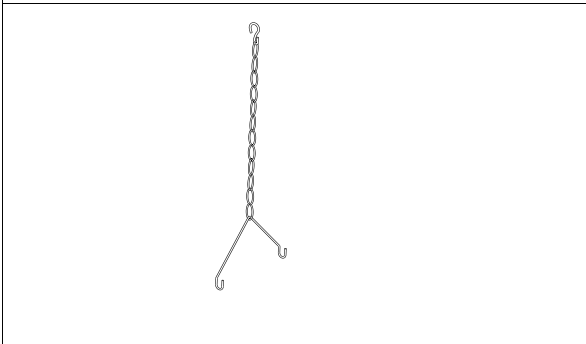

2. Insert the hook into the slotted holes, as shown below.

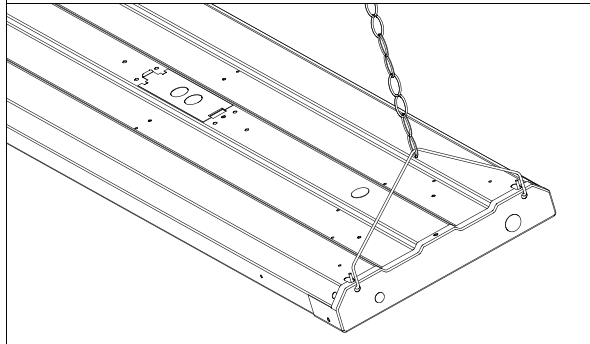

3. Hook up the chain on the ceiling anchor.

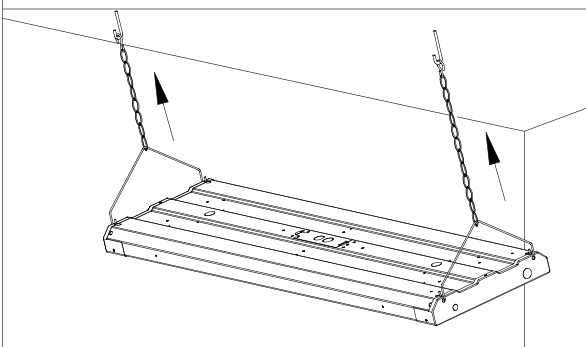

4. Turn off power, and make wiring connections with screw-on wire connectors.

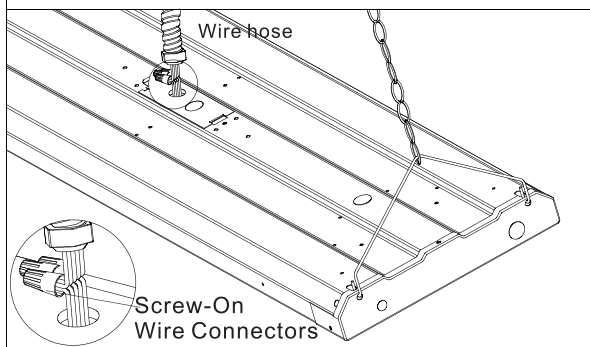

5. Insert the terminal cap and wires into the driver box.

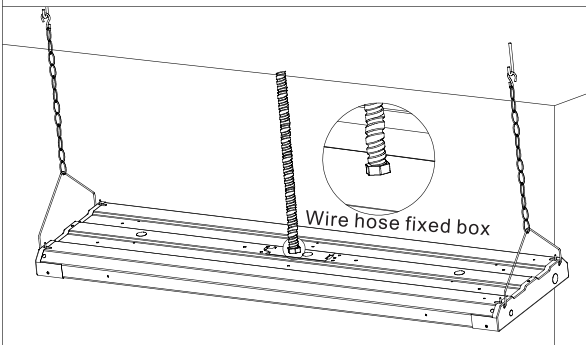

### Wiring instruction

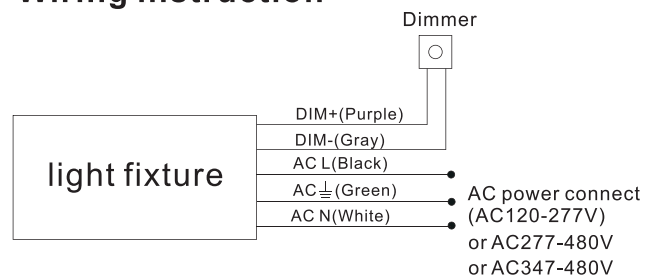

## Surface Mounting instruction

Please turn off the power before installation

1. Drill holes in the ceiling according to the the L bracket holes.

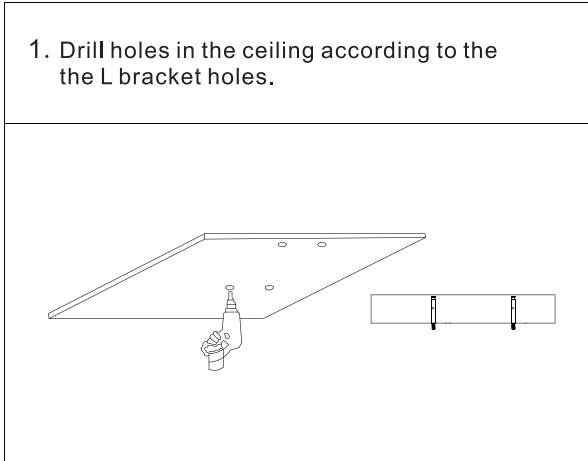

2. Insert the screws into the holes and fix the L brackets with provided accessories.

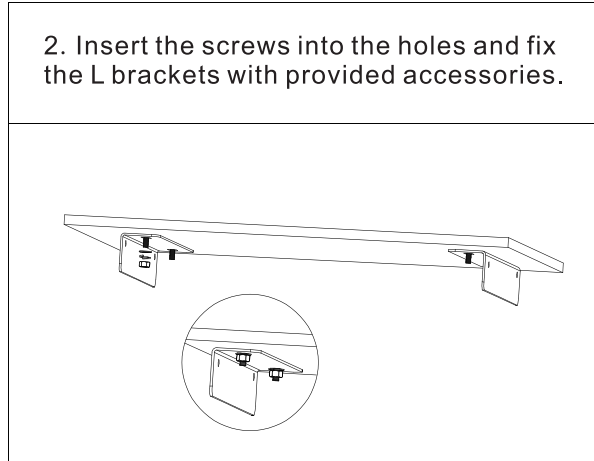

3. Match the holes on each side of the Linear highbay with the L bracket.

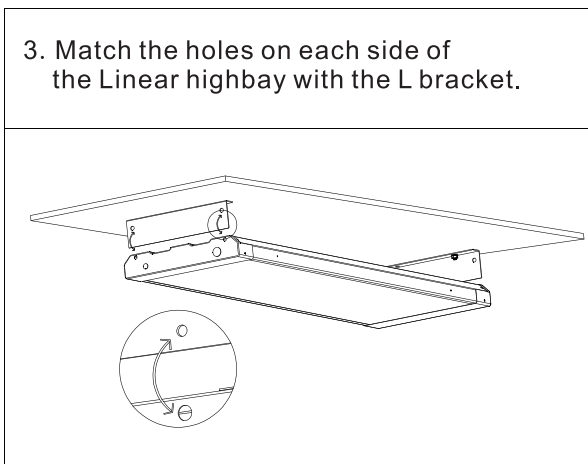

4. Insert screws into the matched holes to fix the Linear Highbay on the L bracket.

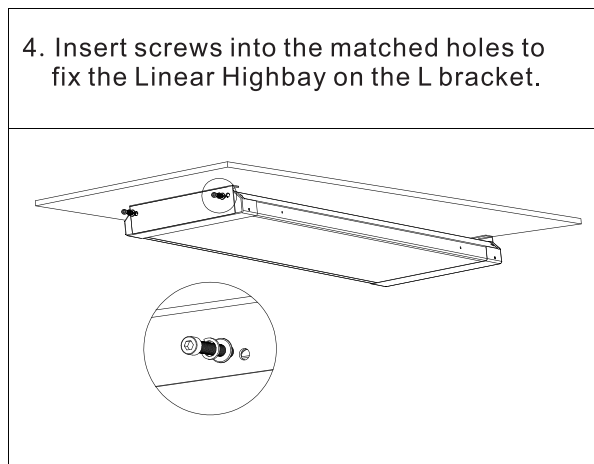

5. Use screws to lock up the linear highbay -together with the L bracket.

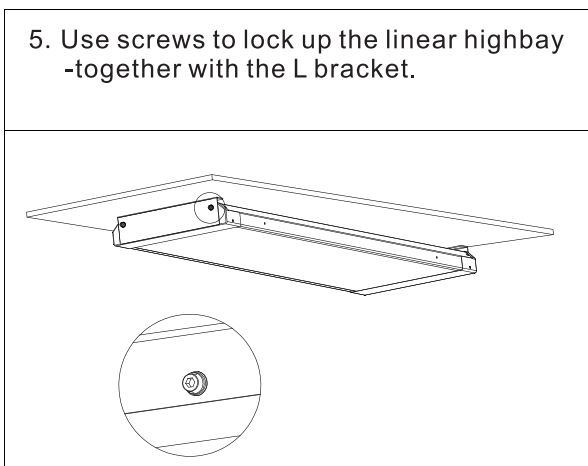

### Wiring instruction

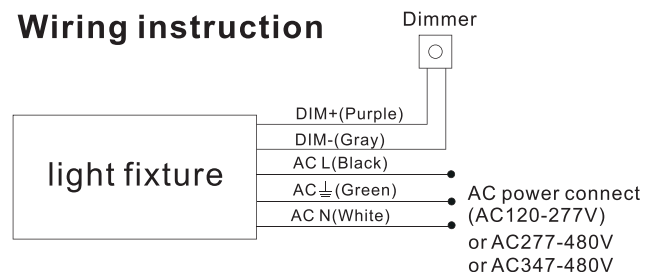

## Pipe installation instruction

Please cut off the power before Installation

1. Fix the expansion screws into the right place on the ceiling.

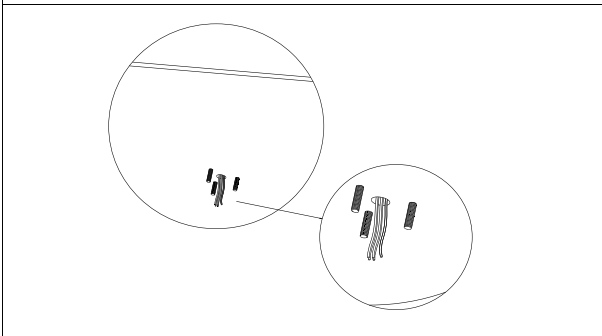

2. Pull wires through the pipe hole and then connect the pipe with u shape brackets by screws.

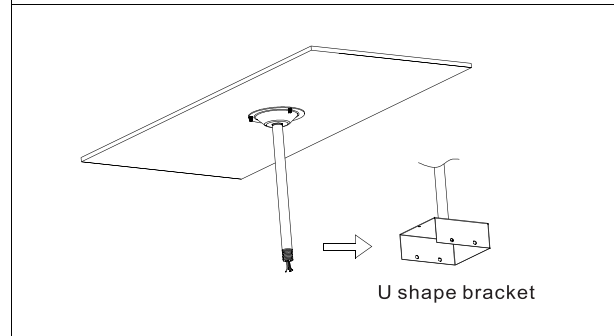

3. Fix the 2pcs L shape bracket with screws 3 holes at the back of the linear highbay.

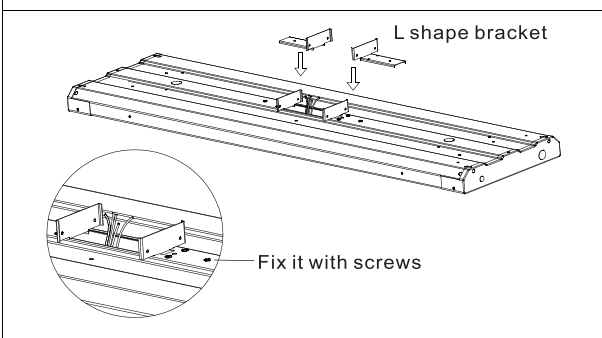

4. Connect u shape brackets with L shape bracket by screws. then make wiring connections with screw-on wire connectors.

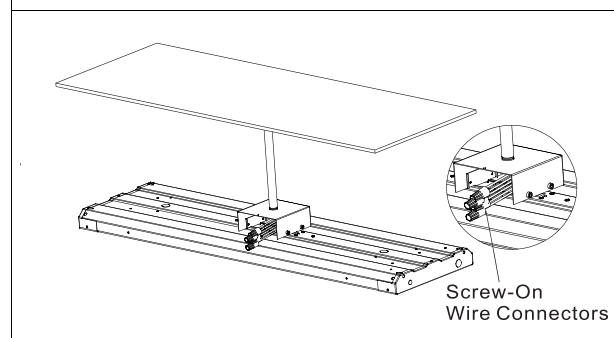

5. Connect the wires, and then Lock the cover with screws.

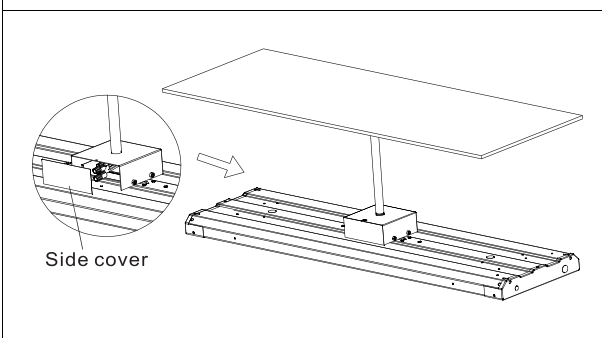

### Wiring instruction

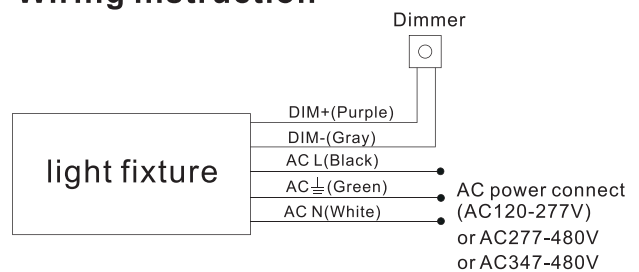



## Microwave motion sensor

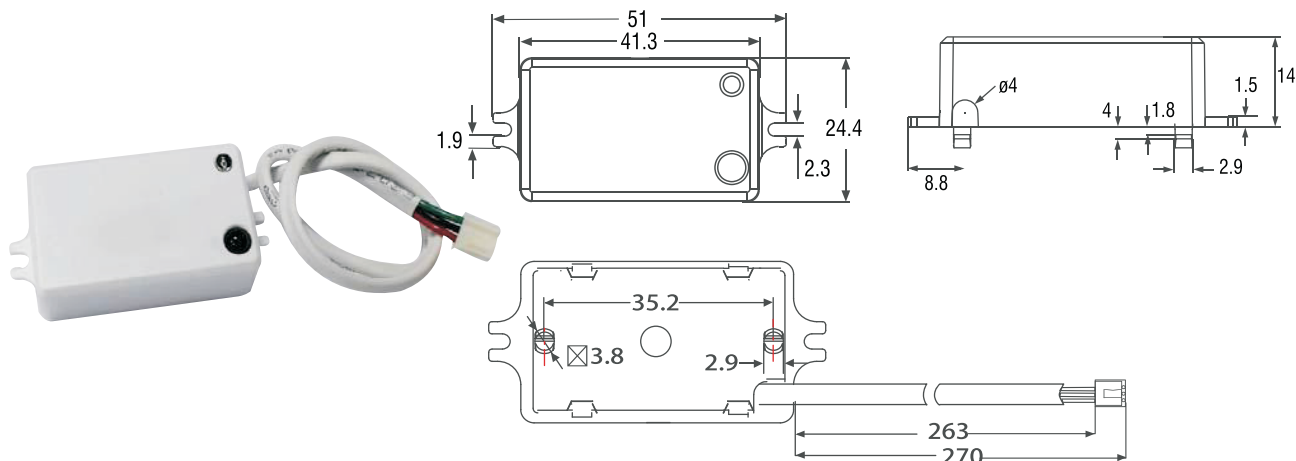

## Technical data

|                        |   |
|------------------------|---|
| Operating voltage      | 12VDC                                       |
| Operating current      | ≤25mA                                       |
| Output                 | DIM/0-10V                                   |
| Stand-by power         | ≤0.5W                                       |
| Detection area         | 25%/50%/75%/100%                            |
| Hold time              | 5s/30s/1min/3min/5min/10min/20min/30min     |
| Daylight threshold     | 2Lux/10Lux/30Lux/50Lux/80Lux/120Lux/Disable |
| Stand-by period        | 0s/10s/30s/1min/5min/10min/30min/+∞         |
| Stand-by dimming level | 10%/20%/30%/50%                             |
| Microwave frequency    | 5.8GHz±75MHz                                |
| Microwave power        | <0.3mW                                      |
| Mounting height        | Max.15m/49.2ft (ceiling mounted)            |
| Detection range        | Max.∅14m/45.92ft (ceiling mounted)          |
| Operating temperature  | -20°C~+60°C                                 |
| Motion detection       | 0.5~1.5m/s                                  |
| IP rating              | IP20  |
| Warranty               | 5 years                                     |

Factory Default Setting: Detection area 100%/ Hold time 5s/ Daylight threshold Disable/Stand-by period 0s/Stand-by dimming level 10%.

**Wiring**

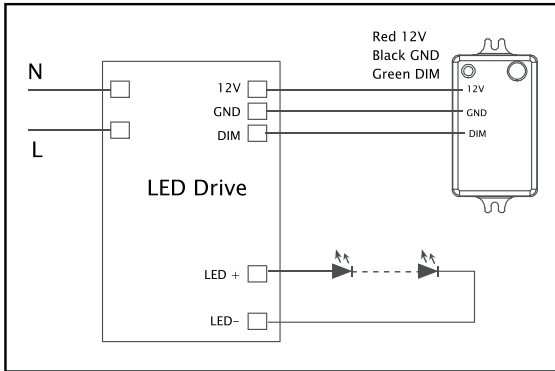

**Structure**

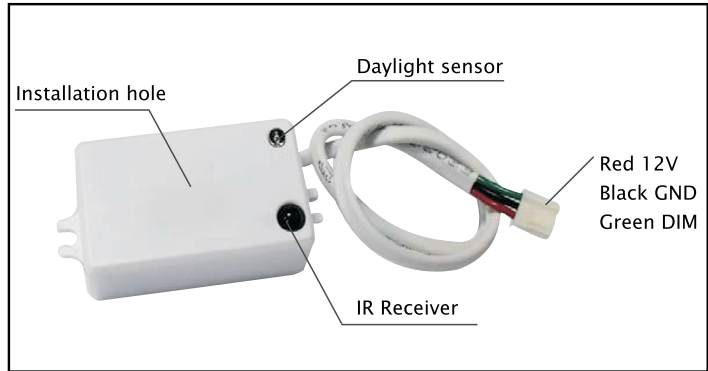

**Mounted To Linear High Bay Light**

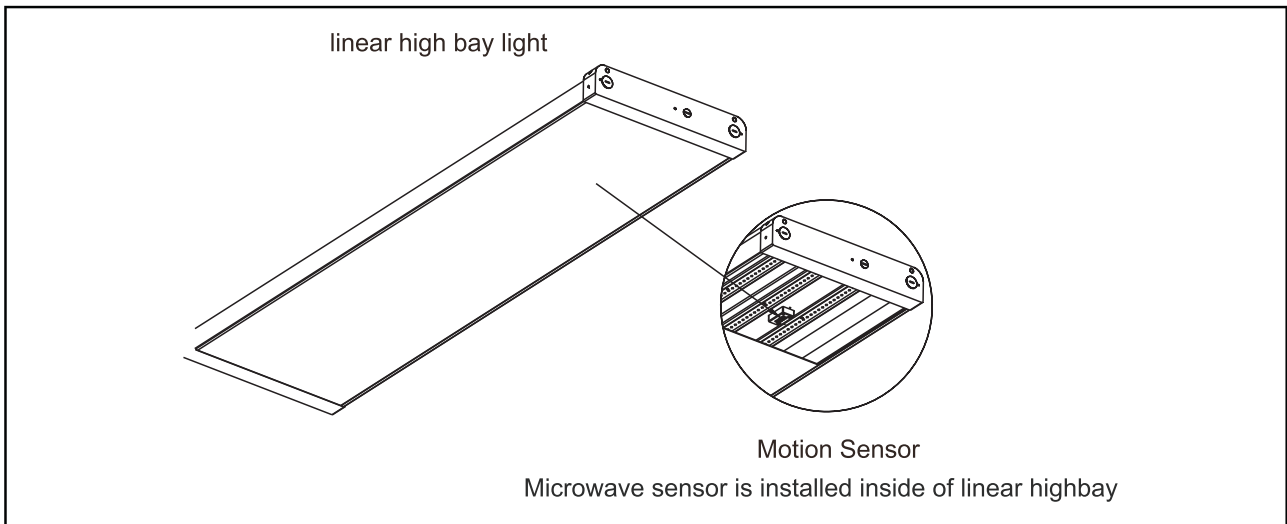

**Function**

● **Detection Patterns**

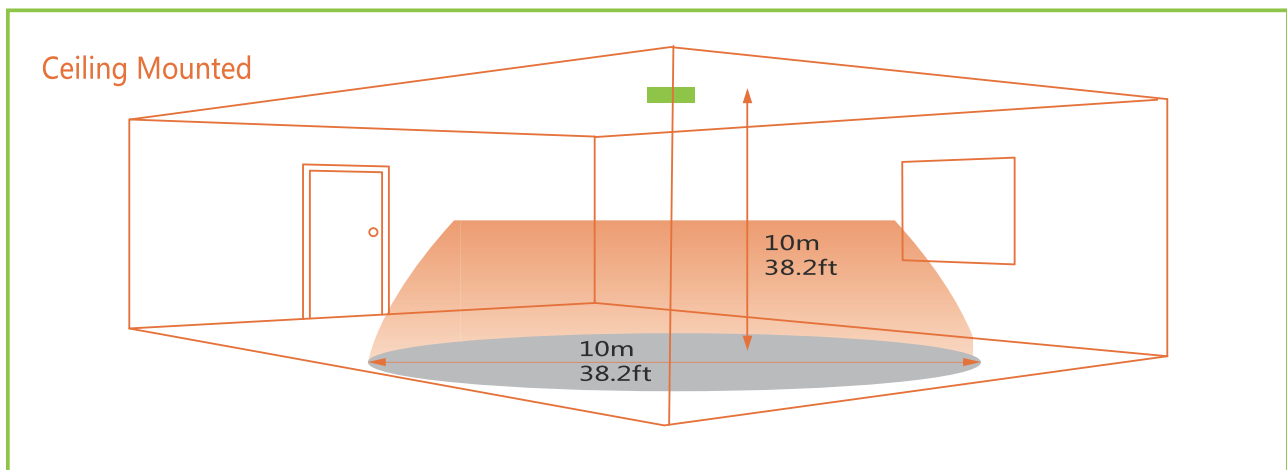

● **Customer can set it according to actual needs with a remote controller.**

**ON/OFF** Press the "On/off" button, the light keeps permanently on or off. Press "Auto Mode", "Reset" or "Apply" buttons to quit from this mode.

**Auto Mode** Press "Auto Mode" button, the sensor starts to work and all settings remain the same before the light gets switched on/off.

**Reset** 1. Press "Reset" button, change brightness to max level.  
2. Press "Reset" button, products with DIP switch will be controlled by DIP switches; otherwise all the setting will be just initial, that is 100% detection range, hold time 5S, no stand-by time and daylight threshold disabled.

Flick after press any button

Flick only after press "Apply" button

**+/-** 1. To adjust brightness 10-100% in on/off mode.  
2. To adjust highest brightness 60-100% in sensor mode.

**Start** Press "Start" to customize scene, users can change detection range, daylight threshold, holdtime, standby dimming level and standby period.

**Memory** 1. Press "Memory" to save all the settings.  
2. The settings remained as the last time if not get resetted values.

**Apply** 1. Press "Apply" to deliver the saved setting.  
2. Press "Apply" without "memory" will make all the setting one-time operation.  
3. Settings should be done within 30S, otherwise it exits memory mode.

**Detection area** Press to define detection area 100%/75%/50%/25%.

**Hold time** Press to define holdtime 5s/30s/1min/3min/5min/10min/20min/30min.

**Stand-by dimming level** Press to define stand-by dimming level 10%/20%/30%/50%.

**Stand-by period** Press to define stand-by period 0s/ 10s/30s/1min/5min/10min/30min/∞.

**Note: "0s" means no standby period; "∞" means unlimited standby period.**

**Daylight threshold** Press to define daylight level 2Lux / 10Lux / 30Lux / 50Lux / 80Lux / 120Lux / Disable.

**Note: Disable means light will be turned on once sensor detects movement, regardless of the ambient lux.**

**Test (2s)** The button "Test (2s)" is for testing purpose after commissioning. Pressing this button, the sensor goes to test mode ( hold time is only 2s )

● **Lux on/off**

Adopted dual PD technology, it is able to differentiate artificial light brightness from natural light after installed inside the fixture, and automatically turn off light when ambient brightness exceeds preset lux level.

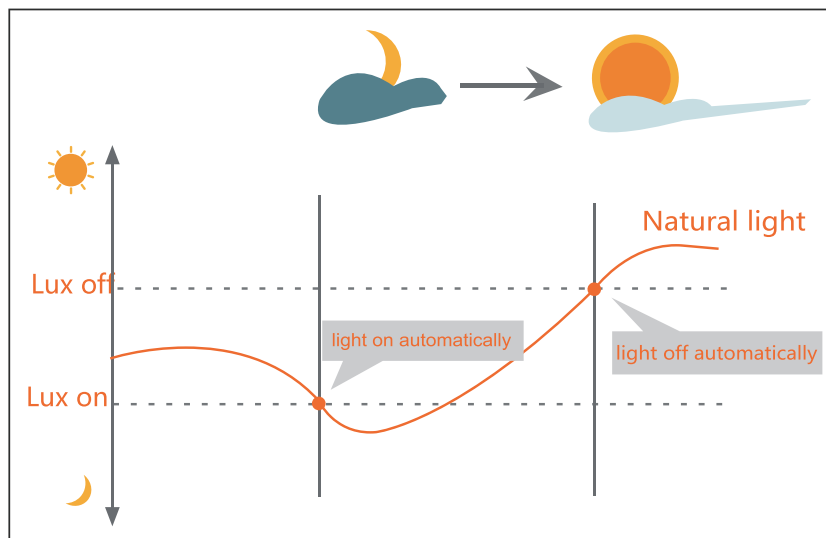

**Preconditions to use the Lux-off function:**

1. Standby period is +∞;
2. Standby dimming level is on 10%, or 50%;
3. Daylight threshold is on 30Lux-50Lux, 80Lux or 100Lux.



● **Application—Lux on/off**

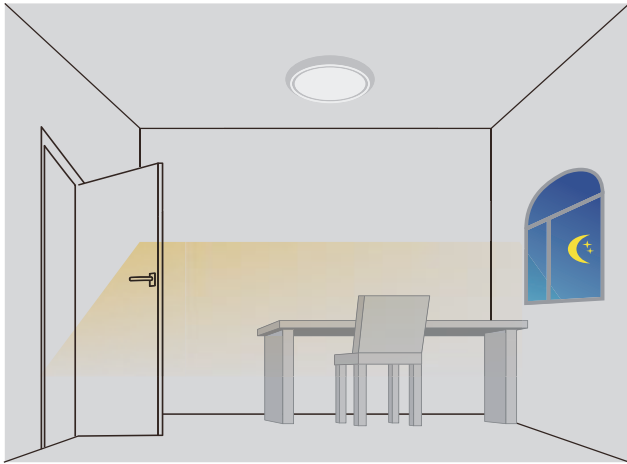

Light automatically on when ambient brightness is lower than preset lux level.



With insufficient ambient brightness, light dims to 100% when motion detected.

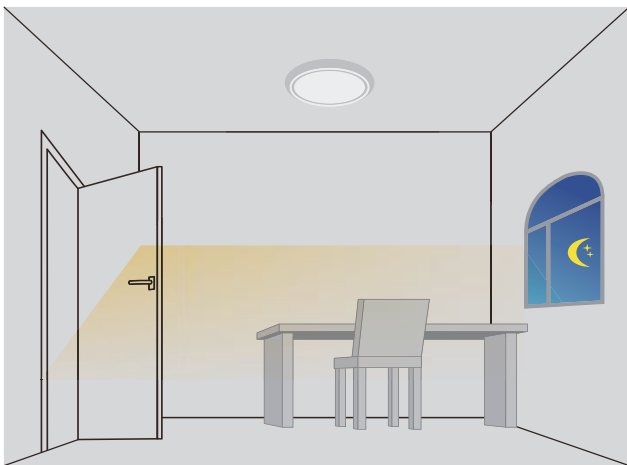

Light dims to standby level if no motion detected after holdtime.

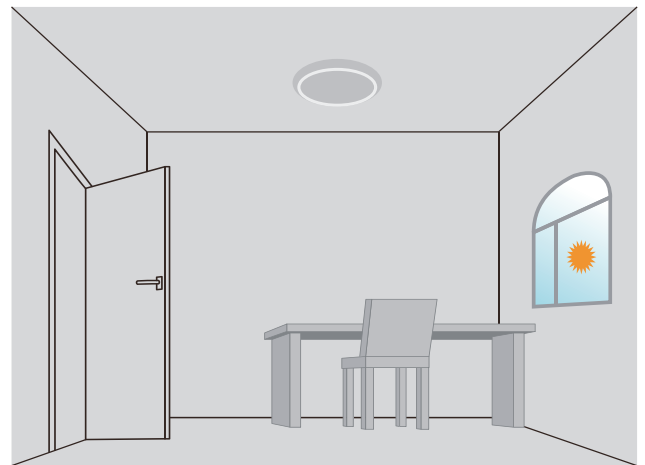

Light off when ambient lux level is higher than preset lux amount.

● **Application—Dimmable control/Corridor function**

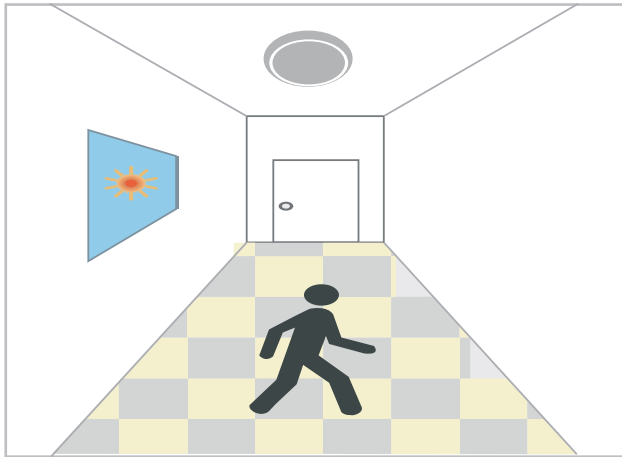

With sufficient daylight, even when motion detected, light remains OFF

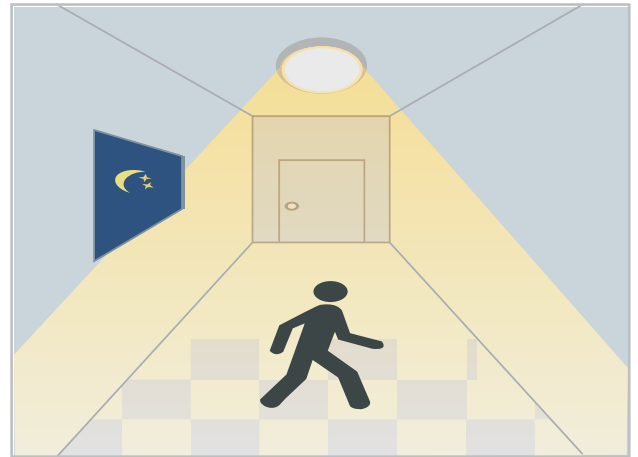

With insufficient daylight, when motion detected, light ON

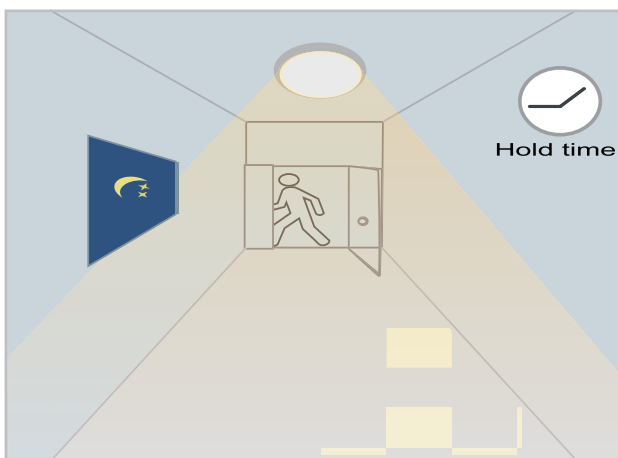

After the stand-by period, light OFF. After last detection, the light will be dimmed down to the stand-by dimming level (10%, 20%, 30% or 50%) after holdtime.

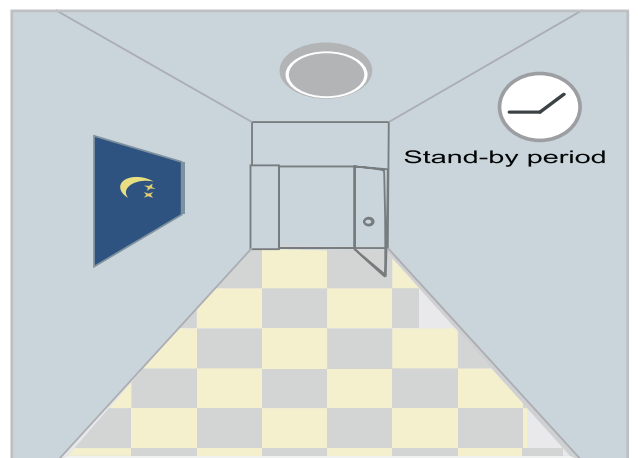

Light dims to standby level if no motion detected after holdtime.

## Emergency LED Driver

### Features

- Easy wiring: directly connect to AC input of LED lamps
- Ideal for many kinds of indoor LED fixtures with 0/1-10V dimming wires  
(Can work with up to 25W LED lamps without dimming function)
- UL Listed for US and Canada.
- Listed for factory or field installation-UL924&CSA C22.2 NO.141
- Constant Power output
- Input voltage: 100-347Vac, 50/60Hz
- Battery protections: over temperature protection, over charge protection  
Over discharge protection, shortcircuit protection.
- Self testing monthly/yearly
- Can work with sensors
- 5 years warranty
- RoHS compliant
- Meet CEC Title 20 standards (california energy commission)



### Specifications

| MODEL NO.           | BLD-HM15D-480800   | BLD-HM20D-480800   | BLD-HM25D-480800   |
|---------------------|--|--|--|
| Input Voltage       | 100-347Vac, 50/60Hz  | 100-347Vac, 50/60Hz  | 100-347Vac, 50/60Hz  |
| Input Current       | <100mA   | <100mA   | <100mA   |
| Input Power         | 8W max   | 8W max   | 8W max   |
| Output Voltage      | ≤175V DC   | ≤175V DC   | ≤175V DC   |
| Output Power        | 15W  | 20W  | 25W  |
| Application         | ① 3.5-100W (0/1-10V Dimmable Fixture)<br>② ≤15W LED Lamps without dimming function | ① 3.5-100W (0/1-10V Dimmable Fixture)<br>② ≤20W LED Lamps without dimming function | ① 3.5-100W (0/1-10V Dimmable Fixture)<br>② ≤25W LED Lamps without dimming function |
| Ambient Temperature | 0°C to +50°C (30°F to 122°F)   | 0°C to +50°C (30°F to 122°F)   | 0°C to +50°C (30°F to 122°F)   |



## Wiring Diagram

0/1-10V Dimmable LED Driver + Dimmer Switch

Emergency Driver Dim+(Yellow) , Driver Dim-(Green) Have to connect with LED driver DIM+ and DIM-

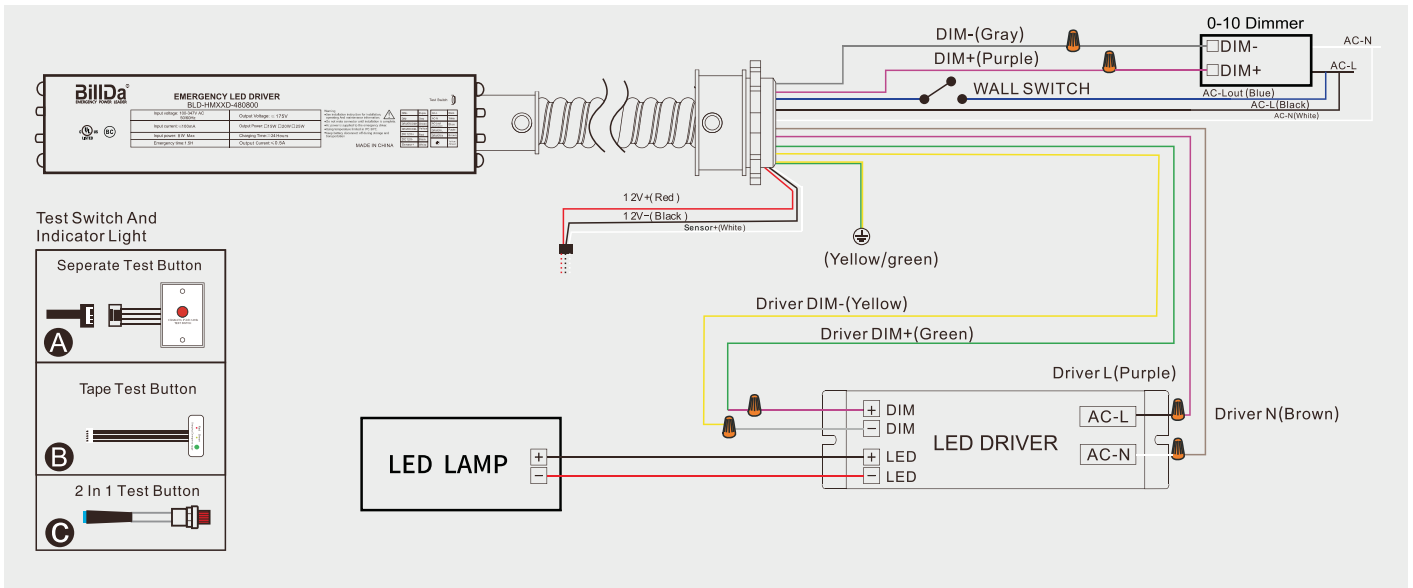

## Dimensions

Case: 12.91" X 1.97" X 0.94" (mounting center 8.62")

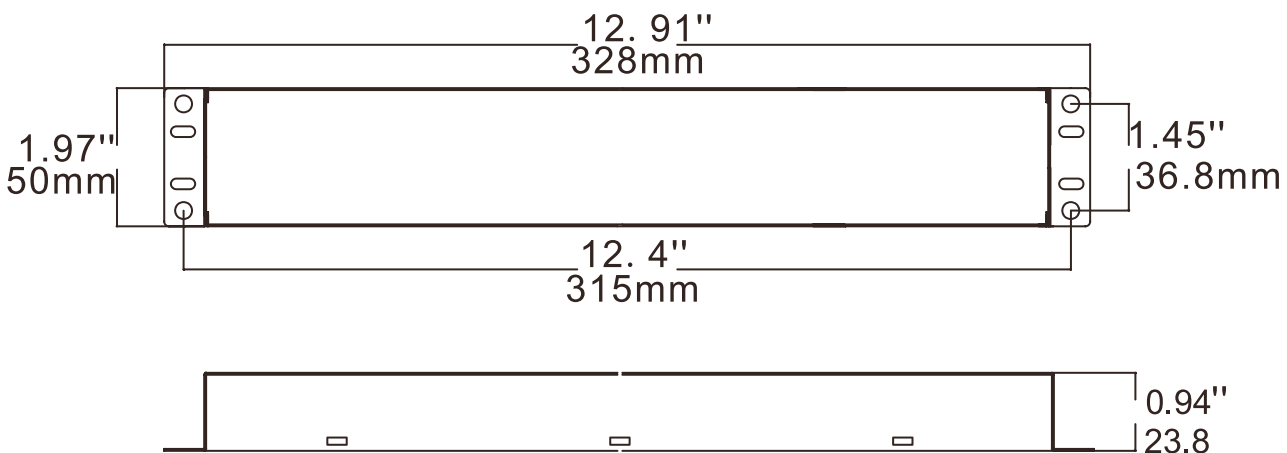

## Emergency LED Driver

The integrated self-diagnostic circuitry will automatically conduct monthly 30-second and annual 90-minute tests to verify proper emergency capability per Life Safety Code requirements.

Press the test button to cut the power to the AC driver and switch the system to emergency mode. Release the test button to return to normal mode. Switch off the circuit breaker to simulate a full power outage.

NFPA 101, Life Safety Code outlines the following schedule:

Monthly- Insure that the test button light is illuminated. Conduct a 30 second discharge test by depressing the test button. The LED load should operate at reduced output.

Annually- Insure that the test button is illuminated. Conduct a full 90 minute discharge test. The unit should operate as intended for the duration of the test.

“Written records of the testing shall be kept by the owner for inspection by the authority having jurisdiction.”

- Risk of fire or electric shock. Luminaire wiring and electrical parts may be damaged when drilling for installation of LED Emergency Backup. Check for enclosed wiring and components.
- Risk of fire or electric shock. This LED Emergency Backup installation requires knowledge of luminaire. electrical systems. If not qualified, do not attempt installation. Contact a qualified electrician.
- Before installing, make certain the AC power to the fixture is off.
- The electrical rating of this product is 100-347Vac. Installer must confirm that there is 100-347Vac to the fixture before installation.
- To prevent electrical shock only mate unit connector after installation is complete and before the AC power to the fixture is back on.
- This LED Emergency Backup unit requires an un-switched AC power source of 100-347Vac, 50/60Hz. The AC driver must be on the same branch circuit as the LED Emergency Backup unit.
- Do not let power supply cords touch hot surfaces.
- Do not mount near gas or electric heaters.
- Do not use outdoors.
- Do not connect battery pack connector until all other wiring is complete and AC power is on.
- The emergency LED driver is for use with grounded, UL listed LED luminaires, shall be enclosed by the LED luminaire and bonded to the grounding of LED luminaire.
- Verify that all replacement lamp types marked on the installed luminaire are also identified as suitable for use with this emergency battery pack.
- The battery pack is fixed by the screw and the indicator lamp is attached to the shell of the luminaire by 3M tape.
- Equipment should be mounted in locations and at heights where it is not be subjected to tampering by unauthorized personnel.
- The use of accessory equipment not recommended by the manufacturer and may cause an unsafe condition.
- Do not use this equipment for other than its intended use.
- Use with grounded, UL Listed, dry or damp location rated fixtures.

## Packing / weight

| Part NO.                         | Outer Carton Size (LxWxH)               | Qty/Carton (pcs) | Net weight (kg)(lbs) | Gross weight (kg)(lbs) | 20GP (QTY) | 40HQ (QTY) |
|----------------------------------|---|------------------|----------------------|------------------------|------------|------------|
| 2FTLHBA-80WLH<br>2FTLHBA-110WLH  | 24.41"*5.39"*13.39"<br>(620*137*340mm)  | 2                | 7.6Kg/16.72lbs       | 8.2Kg/18.04lbs         | 1874       | 4436       |
| 2FTLHBB-165WLH<br>2FTLHBB-220WLH | 24.41"*5.39"*17.91"<br>(620*137*455mm)  | 2                | 9.8Kg/21.56lbs       | 10.55Kg/23.21lbs       | 1394       | 3302       |
| 4FTLHBA-165WLH<br>4FTLHBA-225WLH | 46.38"*5.39"*13.39"<br>(1178*137*340mm) | 2                | 14.0Kg/30.8lbs       | 15.1Kg/32.22lbs        | 982        | 2326       |
| 4FTLHBB-325WLH                   | 46.38"*5.39"*17.91"<br>(1178*137*455mm) | 2                | 21.0Kg/46.2lbs       | 22.5Kg/49.5lbs         | 740        | 1752       |
| 2FTLHBA-110WHH                   | 24.41"*5.39"*13.39"<br>(620*137*340mm)  | 2                | 7.6Kg/16.72lbs       | 8.2Kg/18.04lbs         | 1874       | 4436       |
| 2FTLHBB-165WHH<br>2FTLHBB-220WHH | 24.41"*5.39"*17.91"<br>(620*137*455mm)  | 2                | 9.8Kg/21.56lbs       | 10.55Kg/23.21lbs       | 1394       | 3302       |
| 4FTLHBA-225WHH                   | 46.38"*5.39"*13.39"<br>(1178*137*340mm) | 2                | 14.0Kg/30.8lbs       | 15.1Kg/32.22lbs        | 982        | 2326       |
| 4FTLHBB-325WHH                   | 46.38"*5.39"*17.91"<br>(1178*137*455mm) | 2                | 21.0Kg/46.2lbs       | 22.5Kg/49.5lbs         | 740        | 1752       |

## Packing

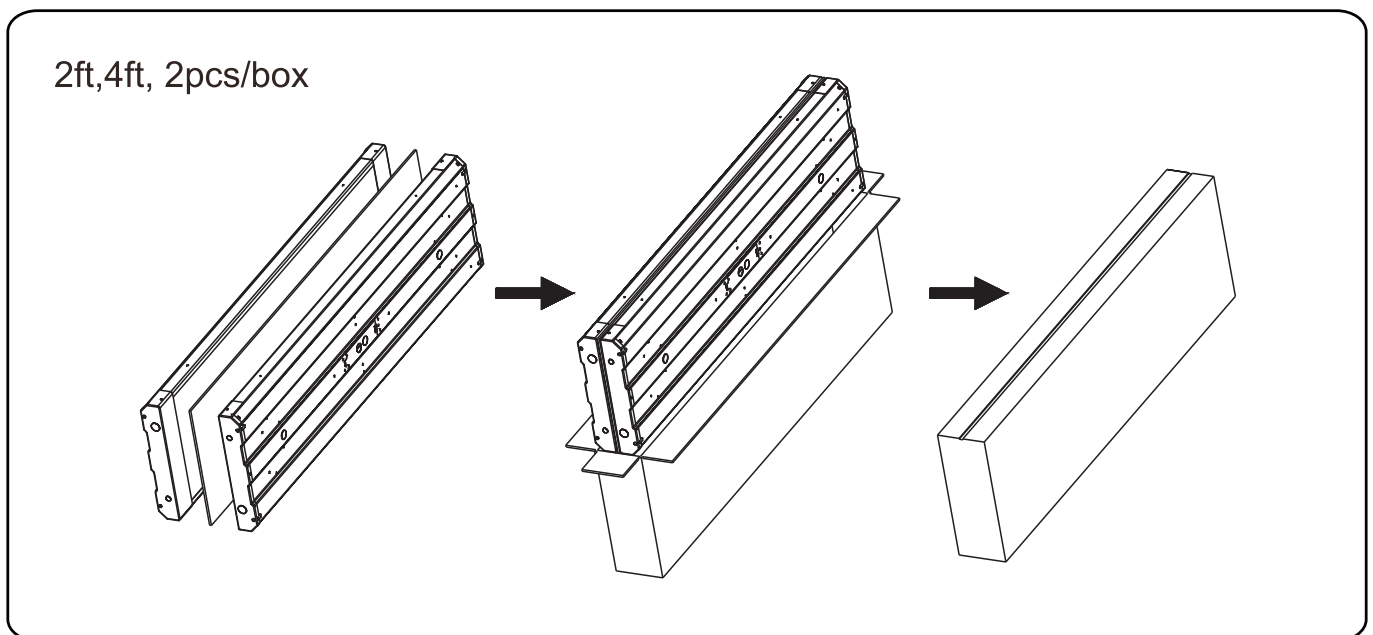



## LED Linear High Bay



### Note

- 1.The installation and maintenance must be completed by electricians or professionals.
- 2.Please cut off the power before installation and maintenance.
- 3.The fixture is not allowed to be covered by thermally insulating material.
4. Please keep away from the corrosive substance,and keep the fixture dry and clean.
5. Working temperature:-4°F~104°F, storage temperature:-22°F~140°F.

# Onward™

T E C H I N C

## ONWARD TECH INC.

 Address: 14243 Don Julian Road.  
City of Industry CA 91746 USA

 Tel : +1 626-820-9300

 Fax : +1 626-820-9299

 Email : [info@onward-tech.com](mailto:info@onward-tech.com)

 Web : [www.onward-tech.com](http://www.onward-tech.com)

## Sunny Opto-electronics Co., Ltd

 Web : [www.sunnyled.net.cn](http://www.sunnyled.net.cn)

