

FRANCIA H

Middle size High-End Performance Class

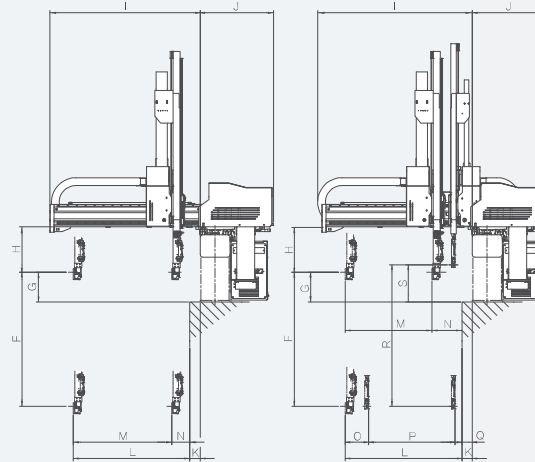
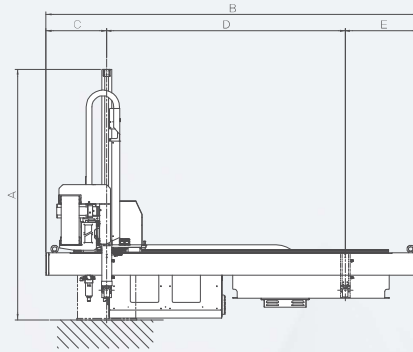

- ▶ I.M.M (ton) 100 - 850
(Horizontal I.M.M)

- ▶ Traverse (mm) 1,600 / 2,300

- ▶ Vertical (mm) 900 / 1,600
(Non-Telescopic arm, Telescopic arm)

- ▶ Driving method All axes AC servo

- ▶ Payload (Kg) 5 / 8 / 15
(Including weight of chuck unit)

- ▶ Power source AC 380V, 50/60 Hz

YUCON-800 Controller

- 8 inch TFT Touch Screen (16,70million color)
- Preferred languages :
Basic supporting 5 languages (Responding to all languages in the world as an option)



Model	Crosswise (X-axis)		Vertical (Y-axis)		Traverse (Z-axis)		Air consumption (L/Cycle(ANP))	Power consumption (KVA)	Payload (Kg)
	Stroke (mm)	Speed (m/s)	Stroke (mm)	Speed (m/s)	Stroke (mm)	Speed (m/s)			
FRANCIA-509i-H	Ⓢ650		Ⓢ900				4,8	3,7	5
FRANCIA-509is-H	Ⓢ580 Ⓢ580	1,5	Ⓢ900 Ⓢ950	3,3	1,600	2,5	4,9	4,9	8
FRANCIA-809i-H	Ⓢ830		Ⓢ900				4,8	4,2	15
FRANCIA-809is-H	Ⓢ670 Ⓢ670	1,5	Ⓢ900 Ⓢ950	3,3	1,600	2,5	4,9	5,4	
FRANCIA-1516i-H	Ⓢ1,240		Ⓢ1,600				4,8	5,7	
FRANCIA-1516is-H	Ⓢ1,040 Ⓢ1,040	1,2	Ⓢ1,600 Ⓢ1,650	3,0	2,300	1,6	4,9	7,3	

* Ⓢ Product side Ⓢ Runner side

Model	Outer dimension (mm)																		
	A	B	C	D	E	F	G	H	I	J	K	L	M	N	O	P	Q	R	S
FRANCIA-509i-H	1,683	2,504	407	1,600	497	900	200	304	1,008	482	50	790	650	140	-	-	-	-	-
FRANCIA-509is-H	1,733	2,504	407	1,600	497	900	200	304	1,008	482	50	790	580	210	156	580	54	950	250
FRANCIA-809i-H	1,779	2,504	428	1,600	476	900	200	328	1,233	504	50	956	830	126	-	-	-	-	-
FRANCIA-809is-H	1,829	2,504	428	1,600	476	900	200	328	1,233	504	50	956	670	286	176	670	110	950	250
FRANCIA-1516i-H	2,067	3,340	462	2,300	578	1,600	300	483	1,782	586	50	1,430	1,230	192	-	-	-	-	-
FRANCIA-1516is-H	2,080	3,340	462	2,300	578	1,600	300	483	1,782	586	50	1,430	1,030	392	249	1,030	143	1,650	350