

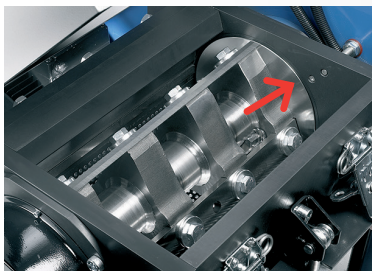

Your recycling needs. Our grinding solutions.

JM Series 20

Technical moulds, reinforced materials, lack of fine parts, minimum noise level, and uniform regrind material, easy and limited maintenance: since many years the series JM has become the most reliable solution for the in-line recovery with injection moulding machines.



Rotary discs integral with the rotor and containment rings. Scissor cutting configuration.

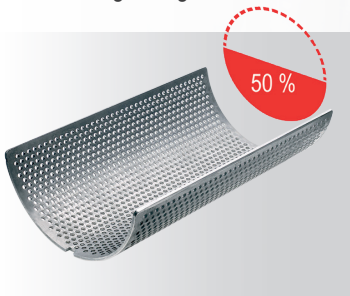

Screen equal to approx. 50% of the blades rotation length.

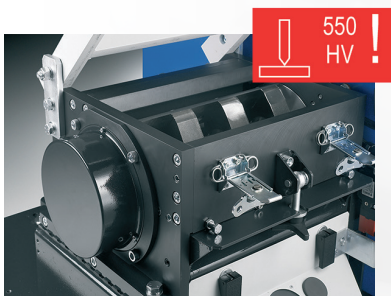

Grinding chamber in antiwear execution 550 HV. Roller bearings, mounted to the grinding chamber and fixed to the circumference.



Access without tools to the main parts subject to ordinary maintenance. Moving on castors.



Integrated electric control panel. Safety devices and circuit in compliance with EEC Directives.

JM Series 20

FEATURES JM 3220

Feeding opening (in): 12.6 x 7.9
 Nr. blades / counter-blades: 3 / 2
 Rotor speed (RPM): 315
 Rotor diameter (mm): 7
 Motor (hp): 4
 Weight (lb): 705
 Standard screen (in): 1/4
 Indicative throughput (lb/hr): 88 - 132

FEATURES JM 4220

Feeding opening (in): 16.5 x 7.9
 Nr. blades / counter-blades: 3 / 2
 Rotor speed (RPM): 315
 Rotor diameter (in): 7
 Motor (hp): 4
 Weight (lb): 840
 Standard screen (in): 1/4
 Indicative throughput (lb/hr): 110 - 175

OPTIONAL

- A) Blades and screen in antiwear execution
- B) Soundproof rigid flap
- C) Not soundproofed version
- D) Level control
- E) Discharge for hopper loader
- F) Discharge with auger screw
- G) EC extractor with storage
- H) Discharge with suction group on board
- I) Discharge with suction group not on board

DIMENSIONS

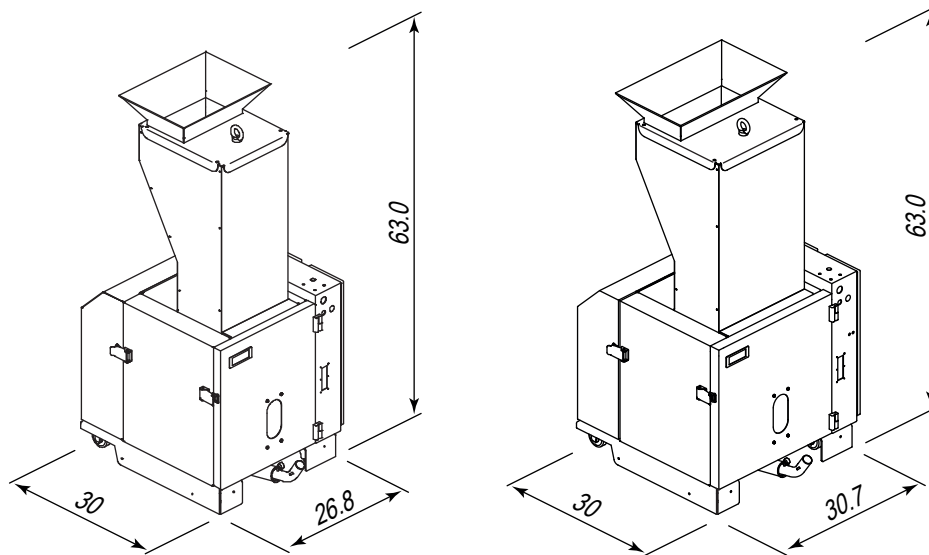

ACCESSORIES

Suction group on board

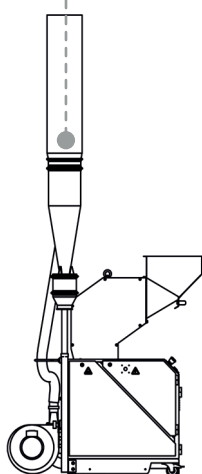

Depowdering system

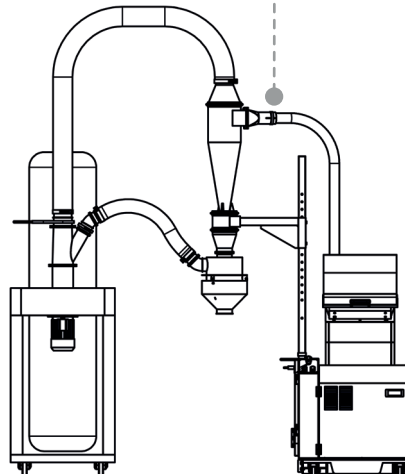

Auger screw

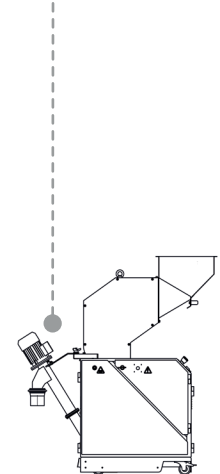

Your recycling needs. Our grinding solutions.

TRIA Italy
www.trioplastics.com

TRIA America
 TRIA Brazil

TRIA China
 TRIA Germany