



Your recycling needs. Our grinding solutions.

XT Series 30

Granulators dedicated to scraps recovery from rigid or flexible extrusion for small sprues or heavy moulds, also suitable for second step grinding of pre-crushed pieces.

The granulators of this series, thanks to the special design of the cutting chamber, are also widely used for an immediate and safe inline grinding of film and trims.

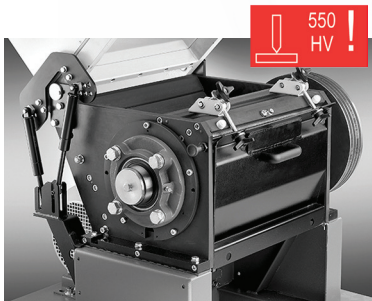

Grinding chamber in 550HV antiwear execution; hopper opening by gas cylinder.



Integrated electric control panel. Safety devices and circuit in compliance with EEC Directives.



Access without tools to the parts subject to the ordinary maintenance. Moving on castors.

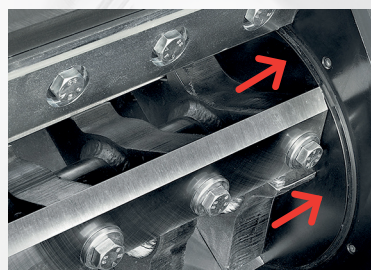

Rotary discs integral with the rotor and containment rings; bench adjustment of blades and counterblades. Scissor cutting configuration.



Chamber water cooling; screen equal to approximately 50% of blades rotation length

XT Series 30

FEATURES XT 3530

Feeding opening (in): **13.8 x 11.8**
 Nr. blades / counter-blades: **3 / 2** Rotor
 speed (RPM): **535**
 Rotor diameter (in): **10.2**
 Motor (hp): **10**
 Weight (lb): **1430**
 Standard screen (in): **1/4 - 9**
 Indicative throughput (lb/hr): **330 - 485**

FEATURES XT 5030

Feeding opening (in): **13.8 x 11.8**
 Nr. blades / counter-blades: **3 / 2** Rotor
 speed (RPM): **535**
 Rotor diameter (in): **10.2**
 Motor (hp): **15**
 Weight (lb): **1650**
 Standard screen (in): **1/4 - 3/8**
 Indicative throughput (lb/hr): **440 - 700**

FEATURES XT 7030

Feeding opening (in): **27.6 x 11.8**
 Nr. blades / counter-blades: **3 / 2** Rotor
 speed (RPM): **535**
 Rotor diameter (in): **10.2**
 Motor (hp): **20**
 Weight (lb): **2200**
 Standard screen (in): **1/4 - 3/8** Indicative
 throughput (lb/hr): **660 - 880**

DIMENSIONS

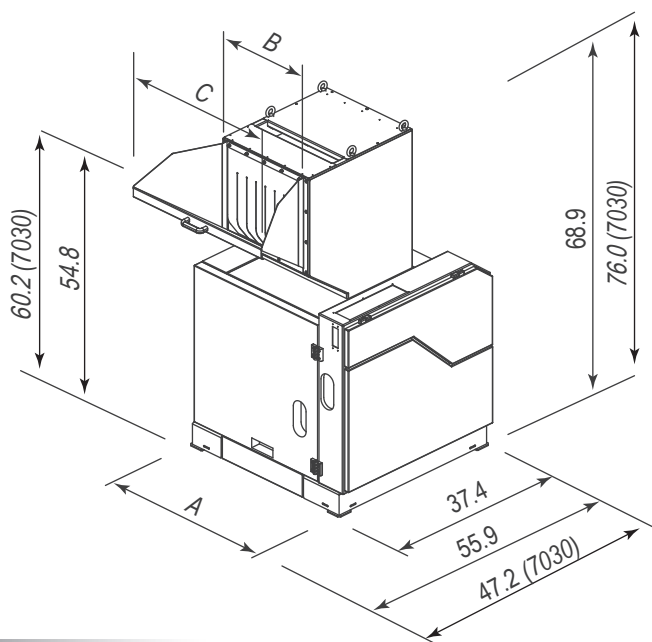

OPTIONAL

- A) Blades and screen in antiwear execution
 - B) Soundproof rigid flap
 - C) Hopper for pipes and sheets
 - D) Not soundproof version
 - E) Hopper for trims
 - F) Aphonic tunnel for conveyor belt
 - G) Level control
 - H) Discharge for power supply
 - I) Discharge with auger screw*
 - L) Discharge with suction group on board
 - M) Discharge with suction group not on board
- (* available only for 3530 and 5030)

CHAMBER SECTION: XT SERIES

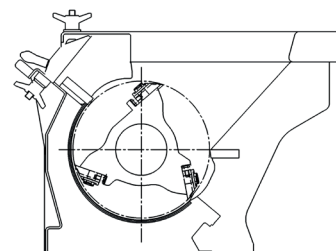

	A	B	C
XT 3530	33.5	13.4	20.5
XT 5030	39.4	19.3	36.4
XT 7030	47.2	27.2	34.3

ACCESSORIES

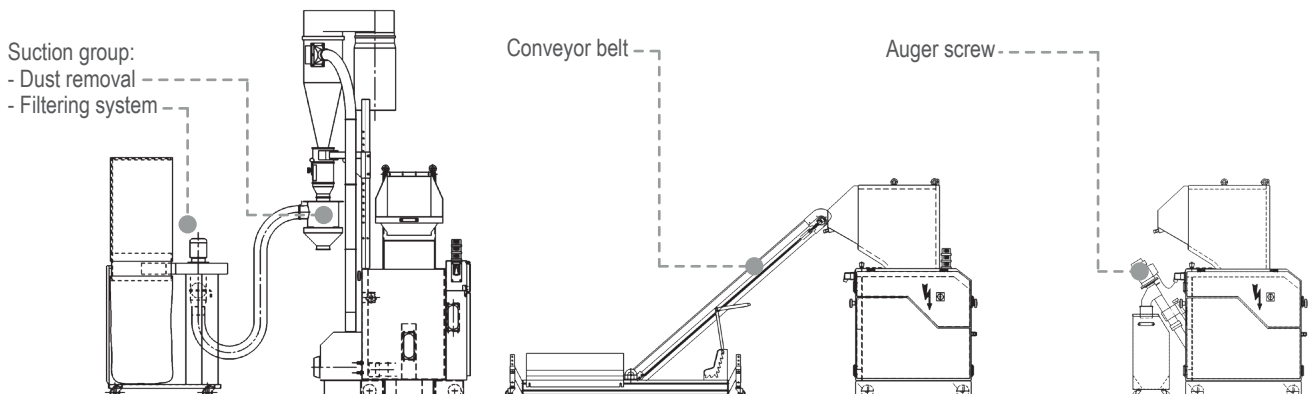

Your recycling needs. Our grinding solutions.

TRIA Italy
www.trioplastics.com

TRIA America
 TRIA Brazil

TRIA China
 TRIA Germany