



# Universal Industries

# P1000

**MAXIMUM CLEANINESS  
DURING OPERATION FOR  
MINIMUM OPERATOR  
CLEANUP**

## BUCKET ELEVATORS

*up to 1,067 ft<sup>3</sup>/h  
(29.88 m<sup>3</sup>/h)  
/857 BPH*



(Guards removed for photos only)

## SPECIFICATIONS

Model	P1000-60	P1000-90
Capacity - Free Flowing Material @ 85% Bucket fill	568 BPH 708 ft <sup>3</sup> /h 20.1 m <sup>3</sup> /h	857 BPH 1,067 ft <sup>3</sup> /h 30 m <sup>3</sup> /h
Short TPH @ 50lbs/ft <sup>3</sup>	17.7 TPH	26.7 TPH
Short TPH @ 75lbs/ft <sup>3</sup>	26.6 TPH	40 TPH
Chain Speed	60 FPM	90 FPM
Headshaft RPM	23.6 RPM	35.6 RPM
Bucket Spacing	6"	6"
Head Casing	11 gauge	
Headshaft Dia.	Determined by discharge height - Consult factory	
Headshaft Bearing	Ball bearing, four bolt flange	
Buckets	8" x 6" HDPE	
Chain	C2060H	
Trunking	14 gauge single trunk	
Boot Casing	11 gauge	
Bootshaft	1" diameter	
Bootshaft Bearing	Ball bearing, four bolt flange	
Construction	Carbon steel (Consult factory for other options)	
Drive Package	Optional	
Motor	Optional	

# THE TRADITION OF EXCELLENCE CONTINUES!

# MODEL P1000

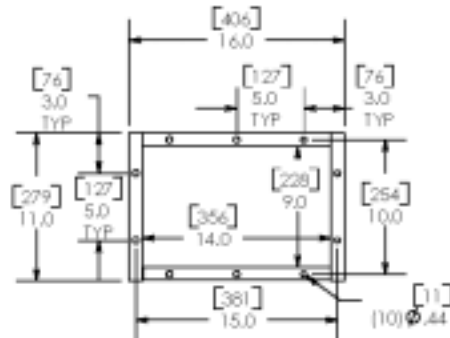

DISCHARGE FLANGE  
BOLT PATTERN

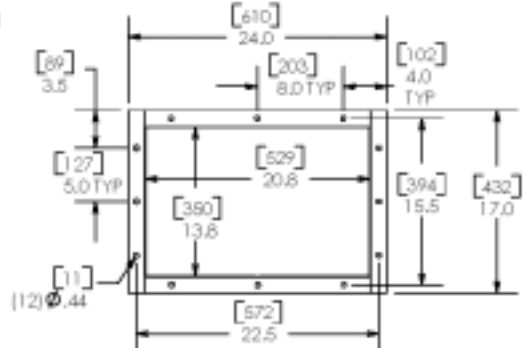

COUPLING FLANGE  
SECTION A-A

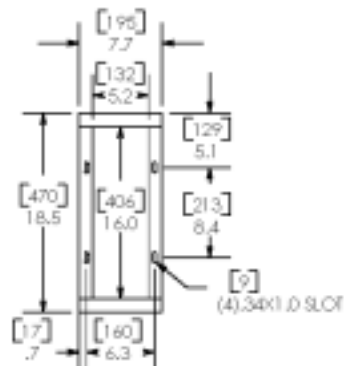

INLET OPENING  
SECTION B-B

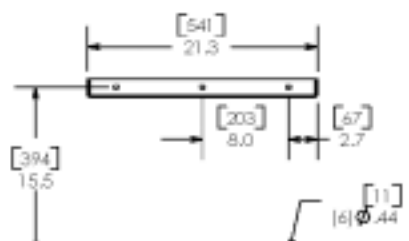

BASE BOLT PATTERN  
SECTION C-C

