



Universal Industries

P2800

BUCKET ELEVATORS

**SLOWER HANDLING SPEEDS
PROVIDE MINIMAL
DAMAGE TO FRAGILE
PRODUCTS**

*up to 2,879 ft³/h
(81.5 m³/h)
/2,313 BPH*

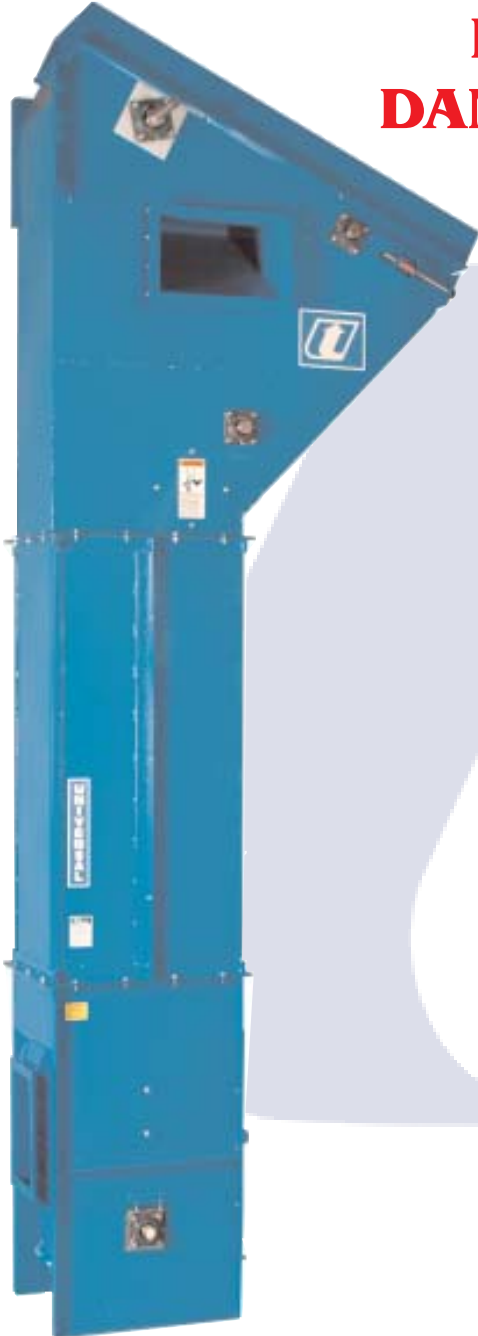

(Guards removed for photos only)

SPECIFICATIONS

Model	P2800-60	P2800-90
Capacity - Free	1,555 BPH	2,313 BPH
Flowing Material @ 75% Bucket fill	1,936 ft ³ /h 54.8 m ³ /h	2,879 ft ³ /h 81.5 m ³ /h
Short TPH @ 50lbs/ft ³	48.4 TPH	72 TPH
Short TPH @ 75lbs/ft ³	72.6 TPH	108 TPH
Chain Speed	60 FPM	90 FPM
Headshaft RPM	14.7 RPM	21.8 RPM
Bucket Spacing	8"	8"
Head Casing	11 gauge	
Headshaft Dia.	Determined by discharge height - Consult factory	
Headshaft Bearing	Ball bearing, four bolt flange	
Buckets	18" x 8" HDPE	
Chain	C2080H	
Trunking	12 gauge single trunk	
Boot Casing	11 gauge	
Bootshaft	1 15/16" diameter	
Bootshaft Bearing	Ball bearing, four bolt flange	
Construction	Carbon steel (Consult factory for other options)	
Drive Package	Optional	
Motor	Optional	

**THE TRADITION OF
EXCELLENCE CONTINUES!**

MODEL P2800

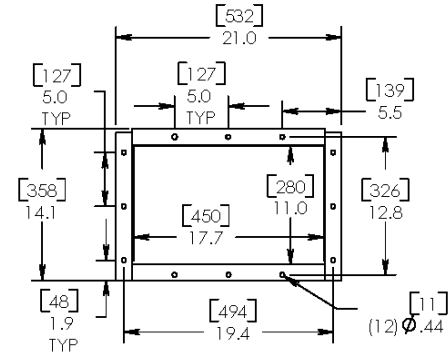
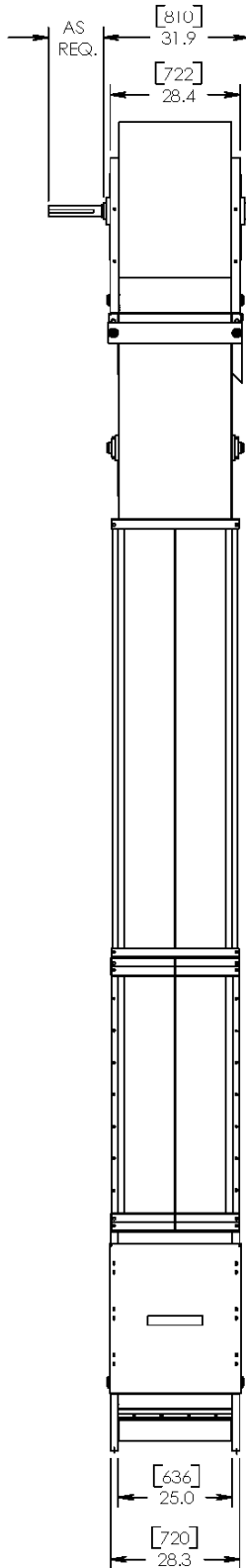

DISCHARGE FLANGE
BOLT PATTERN

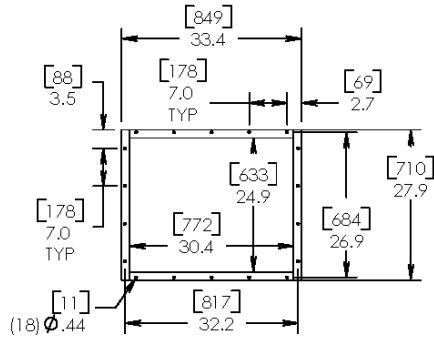

COUPLING FLANGE
SECTION A-A

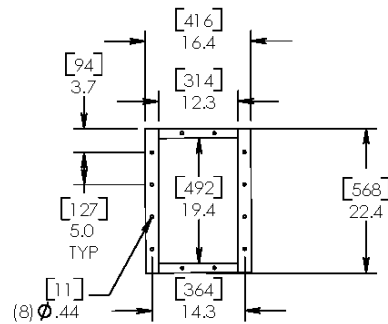

INLET OPENING
SECTION B-B

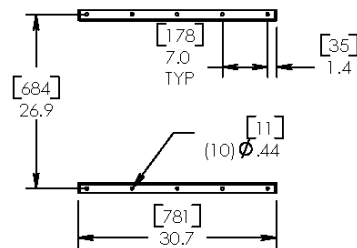

BASE BOLT PATTERN
SECTION C-C

