

REGION 4 AHHA

# 2024 PLAY BOOK

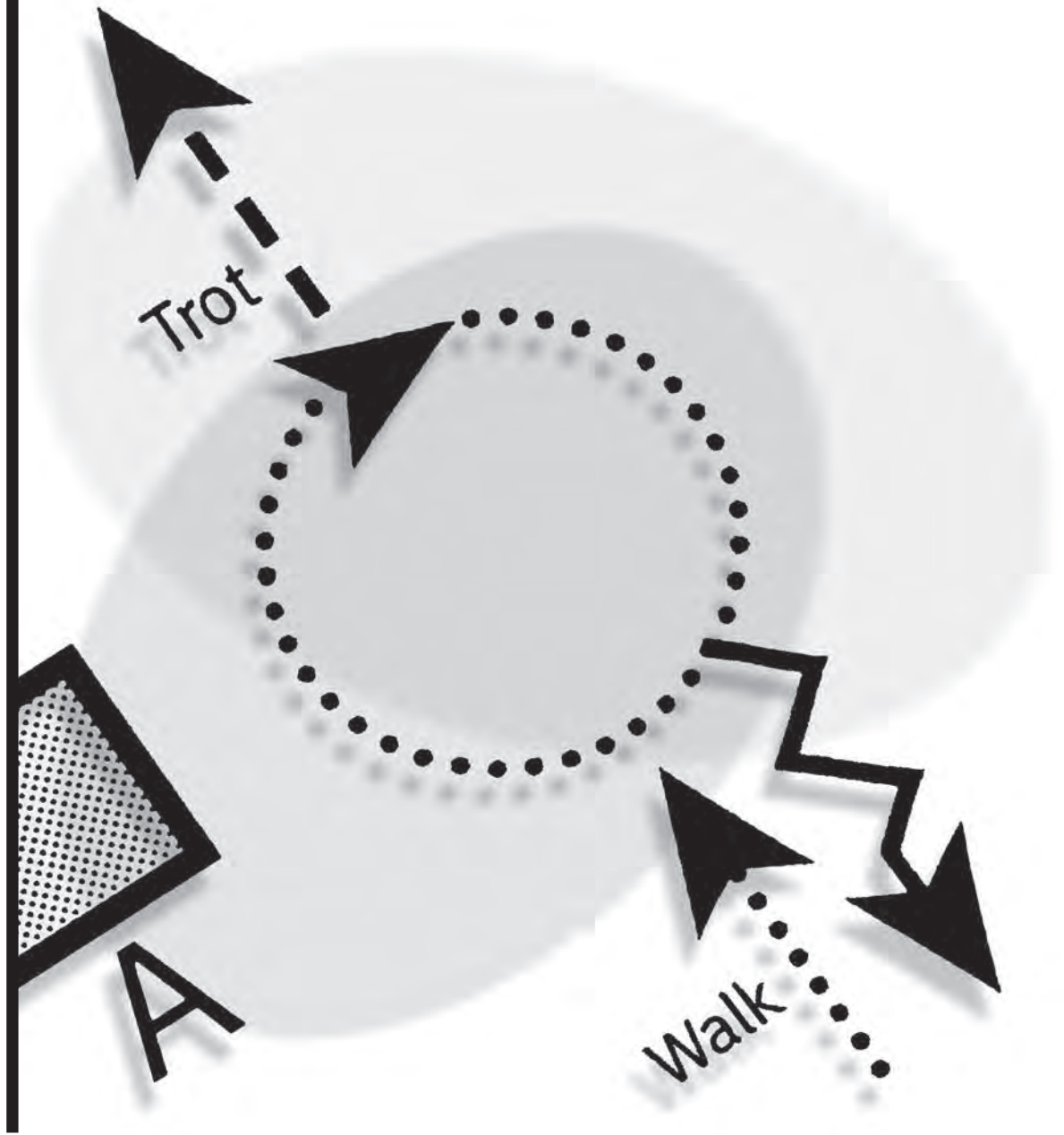

# PATTERNS

*These patterns current as of 04/24/24 from AHA, NRCHA and NRHA*

| <u>Section</u> | <u>Test</u> | <u>Cls.</u> | <u>Class Name</u>  | <u>Call Judge:</u> |
|----------------|-------------|-------------|--|--------------------|
| Horsemanship   | C           | 115         | Western Horsemanship ATR Pattern#C                                 | McGinnis           |
| Horsemanship   | D           | 469         | REGION 4 Western Horsemanship JTR 14 & Under Pattern#D             | Hart               |
| Horsemanship   | Z           | 524         | REGION 4 Western Horsemanship AATR 19-49 Pattern#Z                 | Hart               |
| Horsemanship   | BB          | 468         | REGION 4 Western Horsemanship JTR 15-18 Pattern#BB                 | Hart               |
| Horsemanship   | NN          | 523         | REGION 4 Western Horsemanship AATR 50 & Over Pattern#NN            | Hart               |
| Hunt Seat      | A           | 502         | REGION 4 Hunter Seat Equitation NTJ JTR 14 & Under Pattern#A       | Carson             |
| Hunt Seat      | F           | 108         | Hunter Seat Equitation ATR Pattern#F                               | McGinnis           |
| Hunt Seat      | P           | 503         | REGION 4 Hunter Seat Equitation NTJ JTR 15-18 Pattern#P            | Carson             |
| Hunt Seat      | MM          | 547         | REGION 4 Hunter Seat Equitation NTJ AATR Pattern#MM                | Carson             |
| Saddle Seat    | E           | 584         | REGION 4 Saddle Seat Equitation JTR 15-18 Pattern#E                | Sperte             |
| Saddle Seat    | C           | 585         | REGION 4 Saddle Seat Equitation JTR 14 & Under Pattern#C           | Sperte             |
| Showmanship    | B           | 528         | REGION 4 Walk/Trot 10 & Under Showmanship Pattern#B                | Carson             |
| Showmanship    | C           | 106         | Showmanship ATH Pattern#C  | McGinnis           |
| Showmanship    | F           | 527         | REGION 4 Showmanship JTH 14 & Under Pattern#F                      | Carson             |
| Showmanship    | H           | 487         | REGION 4 Showmanship AATH 50 & Over Pattern#H                      | Carson             |
| Showmanship    | M           | 486         | REGION 4 Showmanship AATH 19 – 49 Pattern#M                        | Carson             |
| Showmanship    | T           | 526         | REGION 4 Showmanship JTH 15-18 Pattern#T                           | Bradley            |
| Ranch Horse    | 9           | 499         | REGION 4 Arabian Ranch Horse Riding Pattern#9                      | Bradley            |
| Ranch Horse    | 12          | 173         | Arabian Ranch Horse Riding Pattern#12                              | Livengood          |
| Ranch Horse    | 12          | 174         | HA/AA Ranch Horse Riding Pattern#12                                | Livengood          |
| Ranch Horse    | 12          | 538         | REGION 4 HA/AA Ranch Horse Riding AATR 19-49 Pattern#12            | Bradley            |
| Ranch Horse    | 12          | 539         | REGION 4 Arabian Ranch Horse Riding AATR 19-49 Pattern#12          | Bradley            |
| Ranch Horse    | 12          | 540         | REGION 4 HA/AA Ranch Horse Riding AATR 50 & Over Pattern#12        | Bradley            |
| Ranch Horse    | 12          | 541         | REGION 4 Arabian Ranch Horse Riding AATR 50 & Over Pattern#12      | Bradley            |
| Ranch Horse    | 12          | 542         | REGION 4 HA/AA Ranch Horse Riding JTR Pattern#12                   | Bradley            |
| Ranch Horse    | 12          | 543         | REGION 4 Arabian Ranch Horse Riding JTR Pattern#12                 | Bradley            |
| Ranch Horse    | 15          | 453         | REGION 4 Arabian Ranch Horse Riding Junior Horse Pattern#15        | Bradley            |
| Ranch Horse    | 15          | 455         | REGION 4 HA/AA Ranch Horse Riding Pattern#15                       | Bradley            |
| Ranch Horse    | 15          | 500         | REGION 4 HA/AA Ranch Horse Riding Junior Horse Pattern#15          | Bradley            |
| Reining        | 2           | 513         | REGION 4 Arabian Reining Horse Pattern#2                           | Bradley            |
| Reining        | 2           | 525         | REGION 4 HA/AA Reining Horse Pattern#2                             | Bradley            |
| Reining        | 3           | 152         | Reining Seat Equitation ATR Pattern#3                              | McGinnis           |
| Reining        | 3           | 442         | REGION 4 Arabian Reining Horse AAOTR Pattern #3                    | Bradley            |
| Reining        | 3           | 492         | REGION 4 Arabian Reining Horse JTR 18 & Under Pattern#3            | Bradley            |
| Reining        | 3           | 493         | REGION 4 HA/AA Reining Horse JTR 18 & Under Pattern#3              | Bradley            |
| Reining        | 3           | 494         | REGION 4 HA/AA Reining Horse AAOTR \$\$ Pattern#3                  | Bradley            |
| Reining        | 4           | 154         | HA/AA Reining Pattern#4  | McGinnis           |
| Reining        | 5           | 153         | Arabian Reining Pattern#5  | McGinnis           |
| Reining        | 5           | 452         | REGION 4 Arabian Reining Horse Junior Horse \$\$ <b>Pattern #5</b> | Bradley            |
| Reining        | 5           | 471         | REGION 4 HA/AA Reining Junior Horse \$\$ Pattern # 5               | Bradley            |
| Reining        | 11          | 447         | REGION 4 Reining Seat Equitation AATR Pattern #11                  | Bradley            |
| Reining        | 11          | 448         | REGION 4 Reining Seat Equitation JTR 15-18 Pattern #11             | Bradley            |
| Reining        | 11          | 449         | REGION 4 Reining Seat Equitation JTR 14 & Under Pattern #11        | Bradley            |
| Reining        | A           | 450         | REGION 4 A/HA/AA Short Stirrup Reining 10 & Under Pattern#A        | Bradley            |

|            |    |     |  |           |
|------------|----|-----|--|-----------|
| Reined Cow | 5  | 304 | REGION 3 Arabian Limited Reined Cow Horse ATR (C3) Pattern#5 | Livengood |
| Reined Cow | 5  | 305 | REGION 3 HA/AA Limited Reined Cow Horse ATR (C3) Pattern#5   | Livengood |
| Reined Cow | 5  | 308 | REGION 3 Arabian Reined Cow Horse (C2) Pattern#5             | Livengood |
| Reined Cow | 5  | 309 | REGION 3 HA/AA Reined Cow Horse (C2) Pattern#5               | Livengood |
| Reined Cow | 5  | 404 | REGION 4 Arabian Limited Reined Cow Horse ATR (C3) Pattern#5 | Bradley   |
| Reined Cow | 5  | 405 | REGION 4 HA/AA Limited Reined Cow Horse ATR (C3) Pattern#5   | Bradley   |
| Reined Cow | 5  | 408 | REGION 4 Arabian Reined Cow Horse (C2) Pattern#5             | Bradley   |
| Reined Cow | 5  | 409 | REGION 4 HA/AA Reined Cow Horse (C2) Pattern#5               | Bradley   |
| Reined Cow | 7  | 163 | Arabian Reined Cow Horse (C2) Pattern#7                      | Livengood |
| Reined Cow | 7  | 164 | HA/AA Reined Cow Horse (C2) Pattern#7                        | Livengood |
| Reined Cow | 7  | 165 | HA/AA Reined Cow Horse ATR (C2) Pattern#7                    | Livengood |
| Reined Cow | 7  | 166 | Arabian Reined Cow Horse ATR (C2) Pattern#7                  | Livengood |
| Reined Cow | 11 | 159 | Arabian Limited Reined Cow Horse ATR (C3) Pattern#11         | Livengood |
| Reined Cow | 11 | 160 | HA/AA Limited Reined Cow Horse ATR (C3) Pattern#11           | Livengood |

# Western Horsemanship

## LEVEL 1 • PATTERN C

*The drawn description of this pattern is only intended for the general depiction of the pattern.  
 Exhibitors should utilize the arena to best exhibit their horses.*

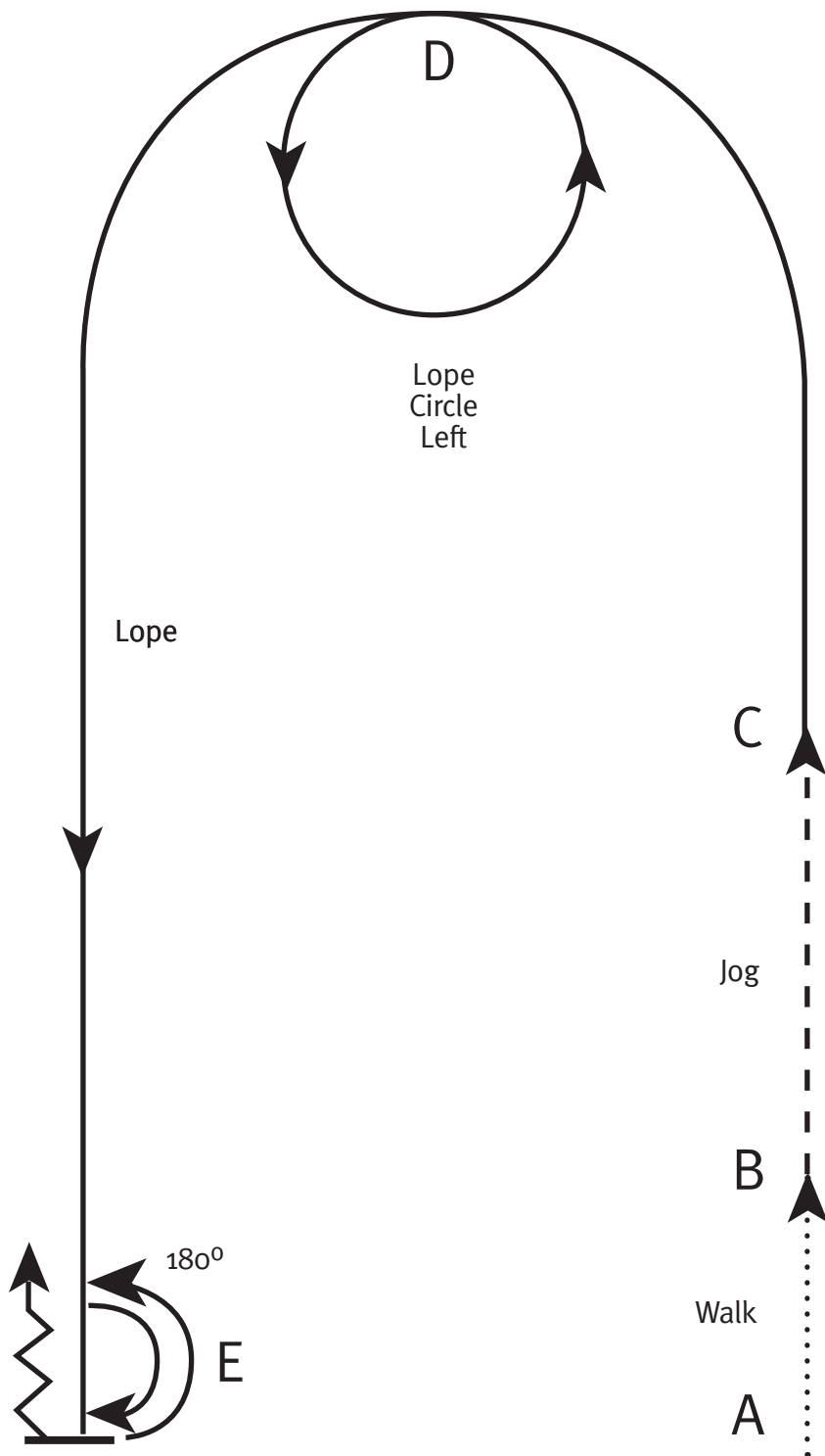

- Be ready at marker A.
- Walk from marker A to marker B.
- Jog to marker C.
- Lope on the left lead to marker D.
- Continue to lope a circle on the left lead around marker D and continue to marker E. Stop.
- Execute a 180-degree on hindquarters to the left.
- Execute a 180-degree turn on hindquarters to the right.
- Back four steps.
- Return to the lineup at the jog or exit arena at the jog.

|  |             |
|--|-------------|
|  | Stop / Halt |
|  | Lope        |
|  | Jog         |
|  | Walk        |
|  | Back        |
|  | Marker      |
|  | Lineup      |

*This pattern is appropriate to use for all age groups*

*If used at a Regional or National Show, pattern may not be run from the lineup.*

# Western Horsemanship

## LEVEL 1 • PATTERN D

The drawn description of this pattern is only intended for the general depiction of the pattern. Exhibitors should utilize the arena to best exhibit their horses.

Be ready at marker A.







Lope a two loop serpentine beginning on the right lead showing one simple change (walk or jog) of lead.

Stop at marker C turn 180-degrees on haunches to the right.

Lope on right lead to marker D.

Stop at marker D and back four steps.

Return to the lineup at the jog or exit arena at the jog.

|   |             |
|---|-------------|
|  | Stop / Halt |
|  | Lope        |
|  | Jog         |
|  | Walk        |
|  | Back        |
|  | Marker      |
|  | Lineup      |

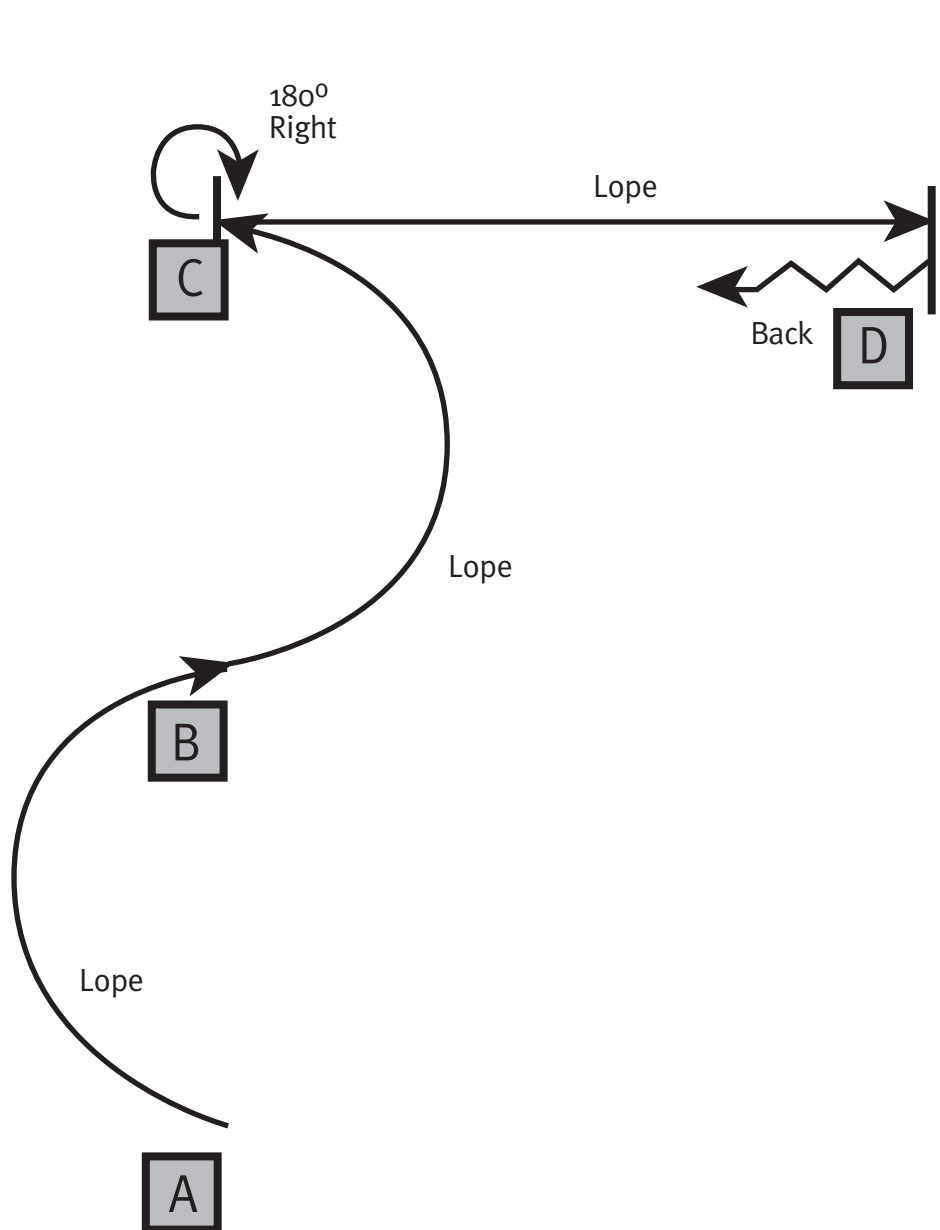

This pattern is appropriate to use for all age groups

If used at a Regional or National Show, pattern may not be run from the lineup.

# Western Horsemanship

## LEVEL 2 • PATTERN Z

The drawn description of this pattern is only intended for the general depiction of the pattern. Exhibitors should utilize the arena to best exhibit their horses.

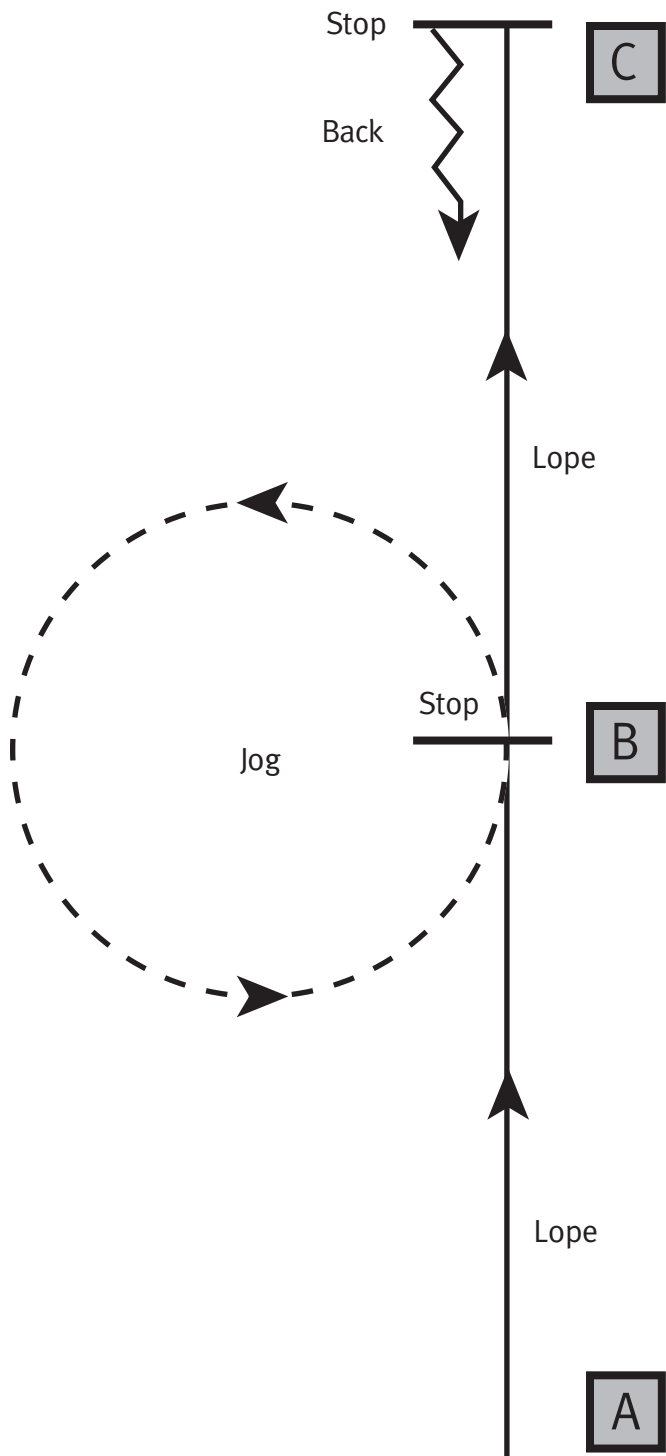

Be ready at marker A.

Lope on the left lead to marker B.  
Stop.

Drop stirrups. Jog a circle to the left and stop. Pick up stirrups.

Lope on the right lead to marker C.

Stop and back four steps.

Return to the lineup at the jog or exit the arena at the jog.

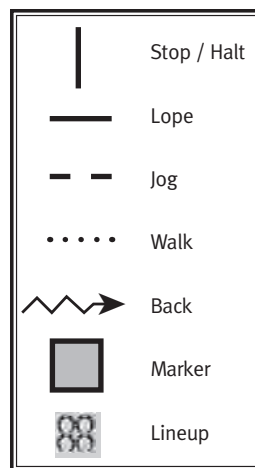

This pattern may only be used for:

- 14 - 18
- 18 & Under
- 19 & Over

This pattern may **NOT** be used for:

- 13 & Under
- 14 & Under

**If used at a Regional or National Show, pattern may not be run from the lineup.**

# Western Horsemanship

## LEVEL 2 • PATTERN BB

The drawn description of this pattern is only intended for the general depiction of the pattern. Exhibitors should utilize the arena to best exhibit their horses.

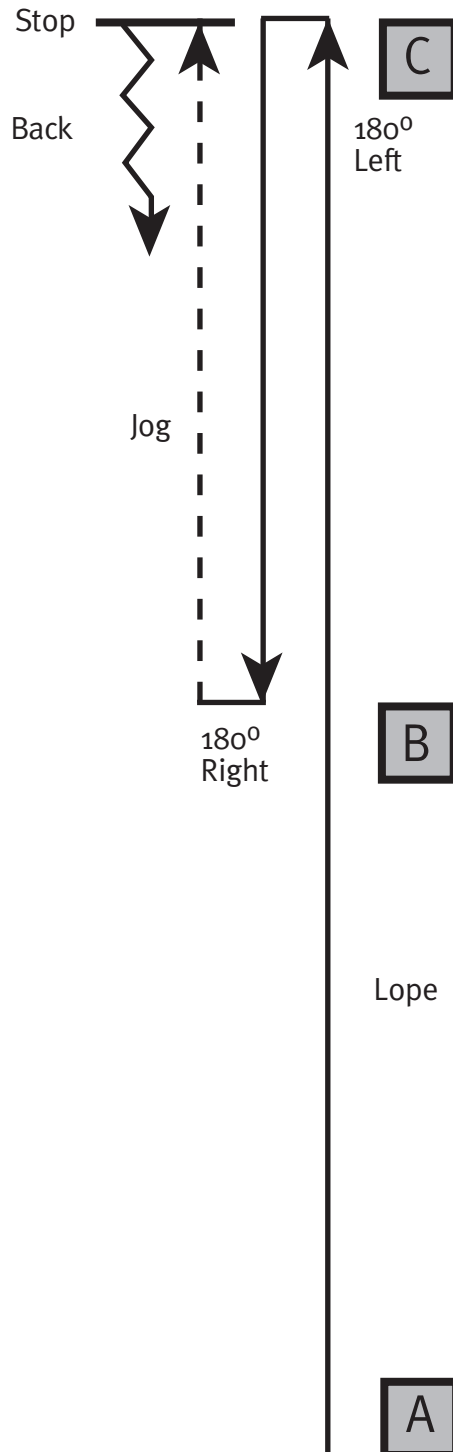

Be ready at marker A.

Lope to marker C on the right lead.

Stop at marker C. Do a 180-degree turn on the haunches to the left.

Lope to marker B on the left lead.

Stop at marker B. Do a 180-degree turn on the haunches to the right.

Drop stirrups. Jog to marker C. Stop and back five steps. Pick up stirrups.

Return to the lineup at the jog or exit the arena at the jog.

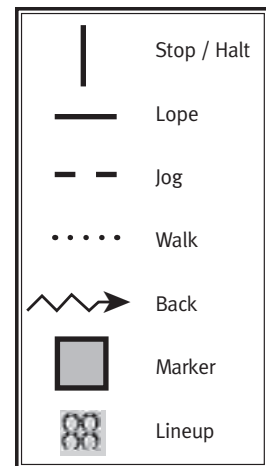

This pattern may only be used for:

- 14 - 18
- 18 & Under
- 19 & Over

This pattern may **NOT** be used for:

- 13 & Under
- 14 & Under

**If used at a Regional or National Show, pattern may not be run from the lineup.**

# Western Horsemanship

## LEVEL 3 • PATTERN NN

The drawn description of this pattern is only intended for the general depiction of the pattern. Exhibitors should utilize the arena to best exhibit their horses.

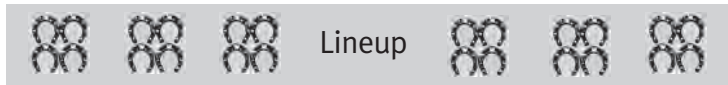
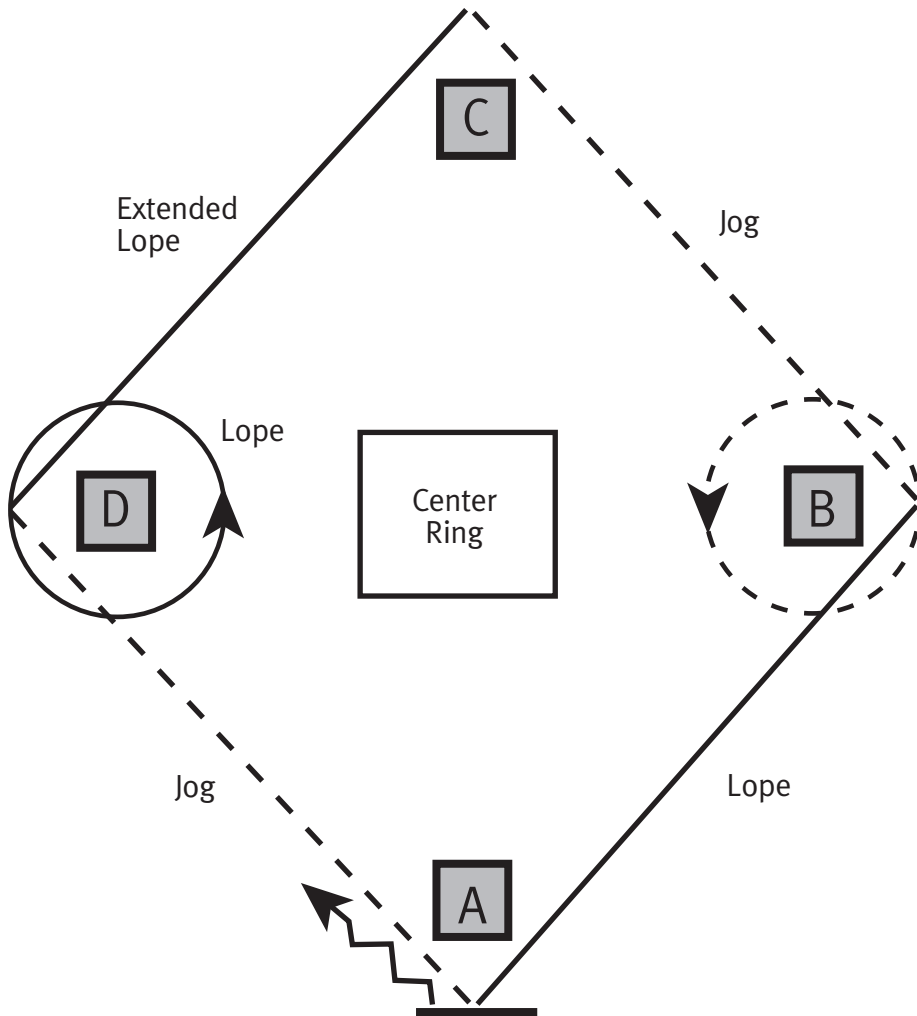

OUT GATE

IN GATE

Be ready at marker A.

Lope right lead to marker B and stop.

At marker B, drop stirrups and jog a circle to the left.

After closing circle, continue at jog to marker C and stop.

Pick up stirrups and then execute the extended lope on left lead to marker D.

Return to a lope and execute a circle to the left.

Upon completion of circle, drop down to jog and jog to marker A and stop.

Back seven steps at marker A.

Return to the lineup at the jog or exit arena at the jog.

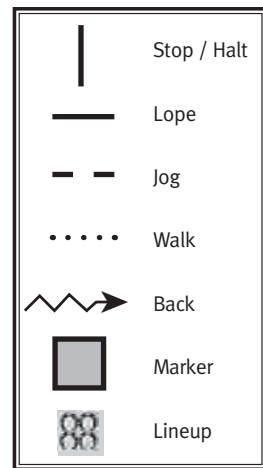

This pattern may only be used for:

- 14 - 18
- 18 & Under
- 19 & Over

This pattern may **NOT** be used for:

- 13 & Under
- 14 & Under

**If used at a Regional or National Show, pattern may not be run from the lineup.**



# Hunter/Jumping Seat

## LEVEL 1 • PATTERN A

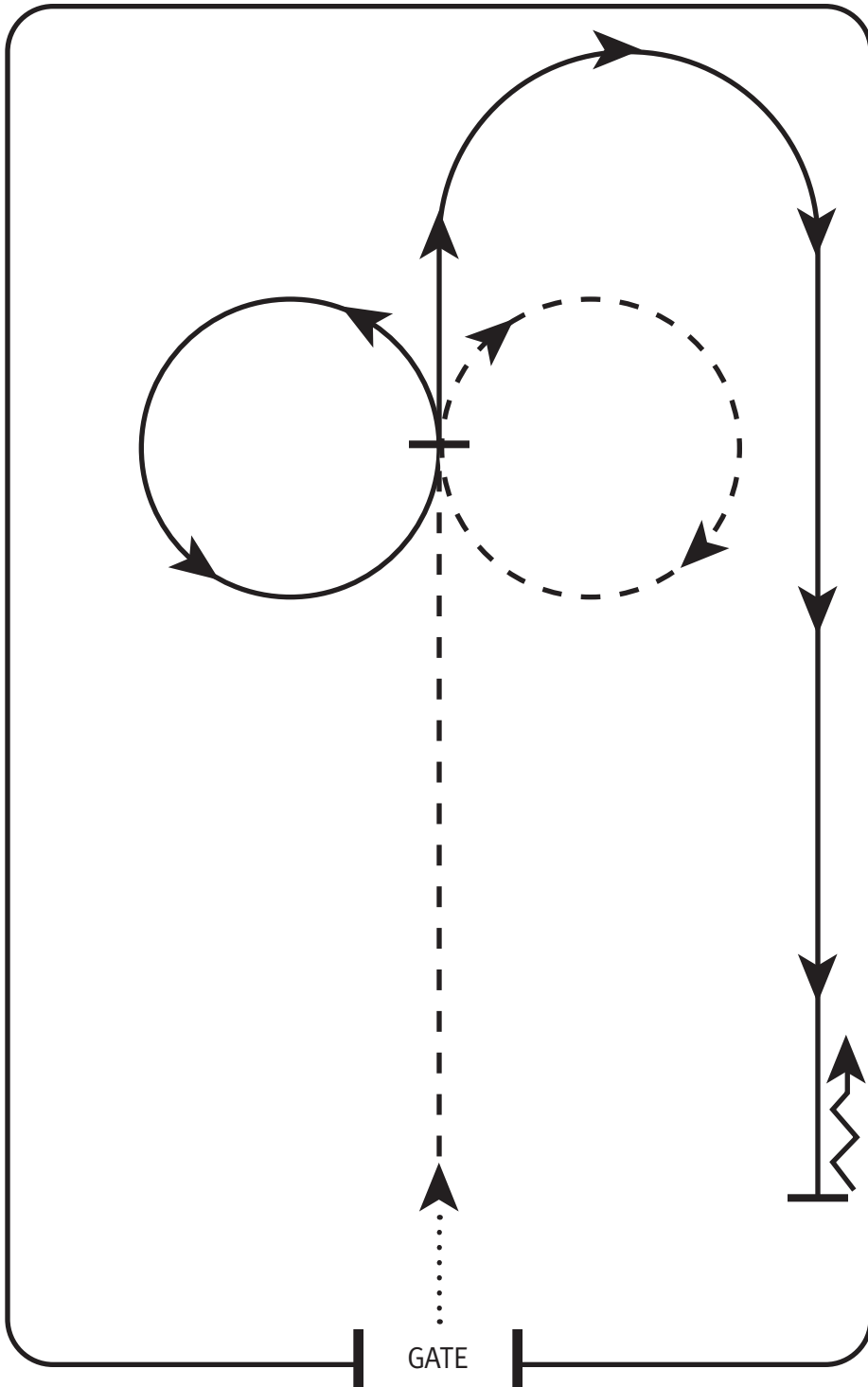

Walk to the starting point.

Trot down the center of the arena on the left diagonal. Continue into a circle to the right at the trot.

Transition to the canter and demonstrate a circle to the left. Halt.

Canter on the right lead around the top of the arena and down the straightaway. Halt. Back five steps.

Return to lineup or exit at a walk.

|  |             |
|--|-------------|
|  | Stop / Halt |
|  | Canter      |
|  | Hand Gallop |
|  | Trot        |
|  | Walk        |
|  | Back        |
|  | Marker      |
|  | Lineup      |

*This pattern is appropriate for all ages.*

*If used at a Regional or National Show, pattern may not be run from the lineup.*

# Hunter/Jumping Seat

## LEVEL 1 • PATTERN F









Walk to the starting point.

At the beginning of the straightaway pick up the sitting trot.

Transition to the canter on the correct lead. At the 3/4 mark of the straightaway execute a canter circle to the left. Continue around the top of the arena and make a half circle to the left. Demonstrate a simple change of lead and canter a circle to the right.

Transition to the trot on the left diagonal. Halt.

Return to lineup or exit at a walk.

|   |             |
|---|-------------|
|  | Stop / Halt |
|  | Canter      |
|  | Hand Gallop |
|  | Trot        |
|  | Walk        |
|  | Back        |
|  | Marker      |
|  | Lineup      |

*This pattern is appropriate for all ages.*

*If used at a Regional or National Show, pattern may not be run from the lineup.*

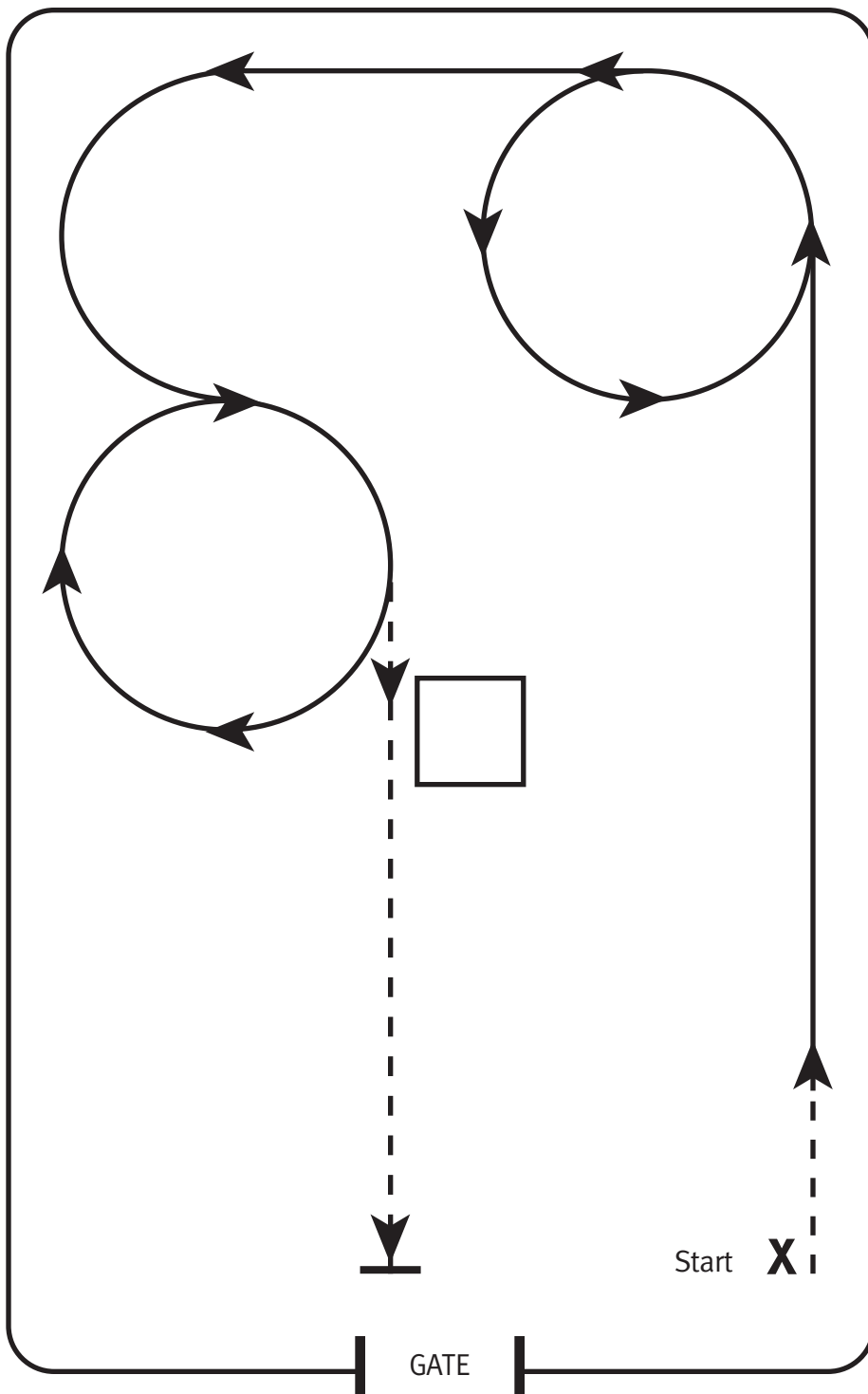

# Hunter/Jumping Seat

## LEVEL 1 • PATTERN P

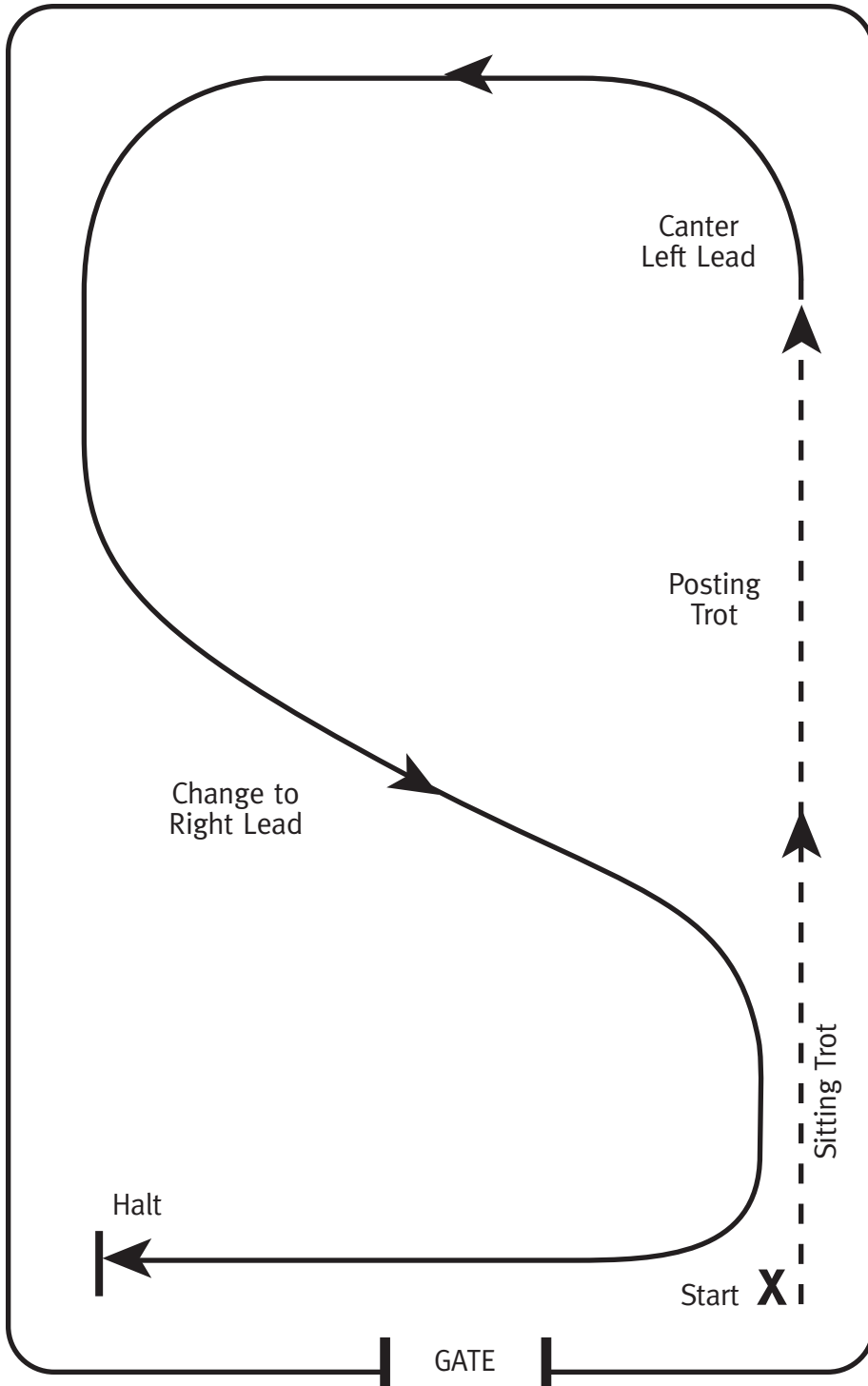

- Walk to the starting point.
- Pick up sitting trot.
- Continue at posting trot on the correct diagonal.
- Pick up canter, correct lead.
- Cut diagonally across arena and change lead (simple change).
- Continue around end of arena.
- Halt.
- Return to lineup or exit at a walk.

|  |             |
|--|-------------|
|  | Stop / Halt |
|  | Canter      |
|  | Hand Gallop |
|  | Trot        |
|  | Walk        |
|  | Back        |
|  | Marker      |
|  | Lineup      |

*This pattern is appropriate for all ages.  
 If used at a Regional or National Show,  
 pattern may not be run from the lineup.*

# Hunter/Jumping Seat









## LEVEL 1 • PATTERN MM

Walk to the starting point.

Demonstrate a hand gallop on the correct lead going down the rail. At the corner transition to the canter.

On the left side of the arena demonstrate a three loop serpentine with the first two loops at the posting trot and the third loop at the sitting trot. Halt.

Return to the lineup or exit the arena at the walk.

|   |             |
|---|-------------|
|  | Stop / Halt |
|  | Canter      |
|  | Hand Gallop |
|  | Trot        |
|  | Walk        |
|  | Back        |
|  | Marker      |
|  | Lineup      |

*This pattern may only be used for:*

- 14 - 18
- 18 & Under
- 19 & Over

*This pattern may **NOT** be used for:*

- 13 & Under
- 14 & Under

*If used at a Regional or National Show, pattern may not be run from the lineup.*

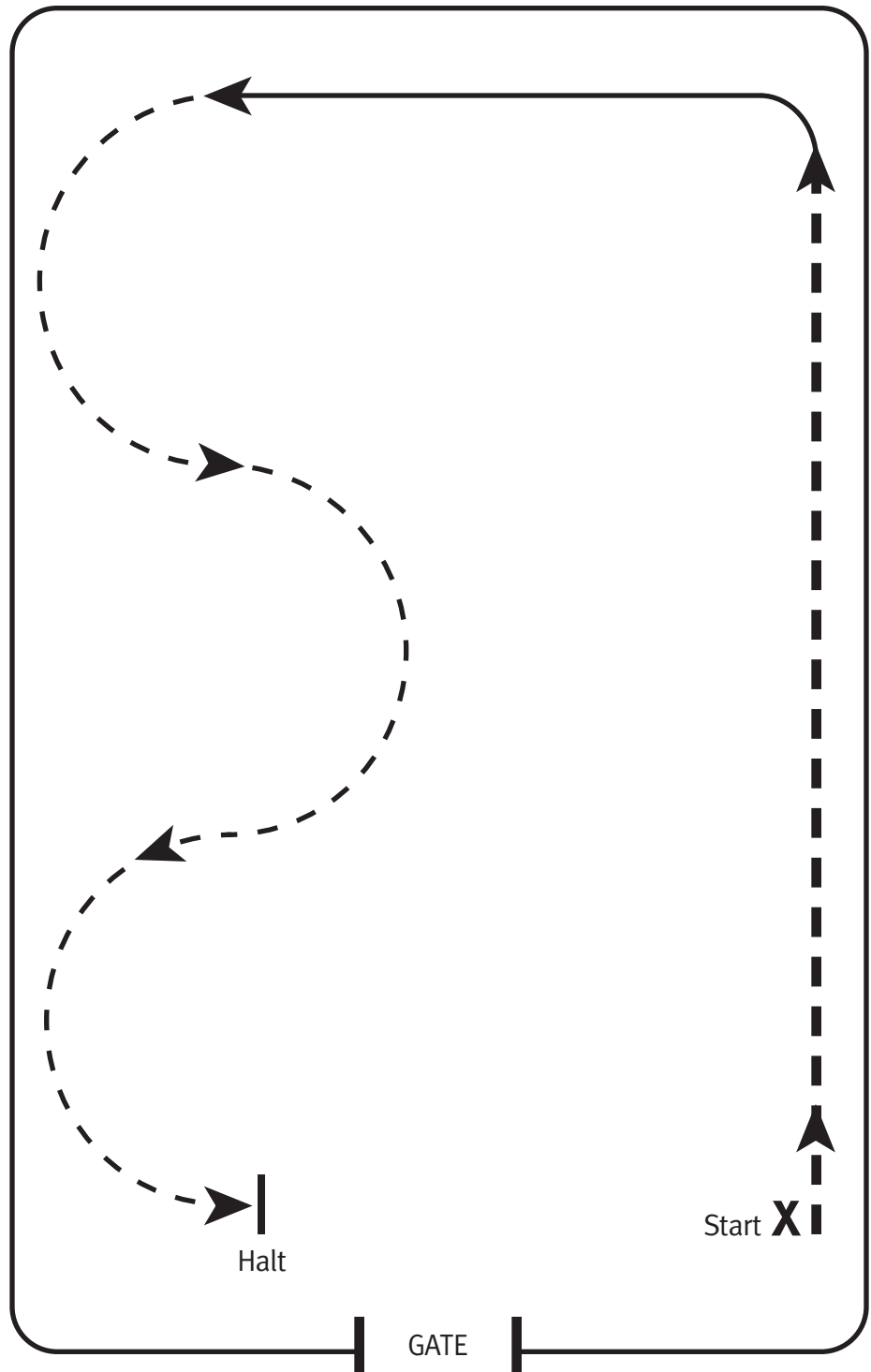

# Saddle Seat

## LEVEL 1 • PATTERN C • Tests 6,10

From the lineup, trot down the right hand straightaway showing two changes of diagonal. Begin on the right diagonal. Continue trotting to the center of the end. Halt.

Canter a circle on the left lead. Halt.

Trot from the center of the end down the opposite straightaway on the right diagonal. Return to the lineup without stopping, or continue to the exit at the trot.

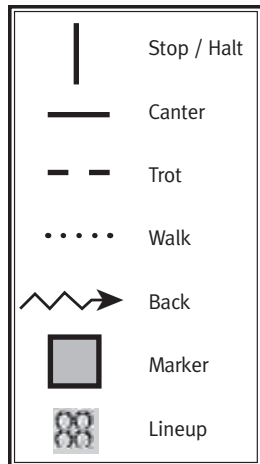

*This pattern may only be used for:*

- 13 & Under
- 14 - 18
- 18 & Under
- 19 & Over

***If used at a Regional or National Show, pattern may not be run from the lineup.***

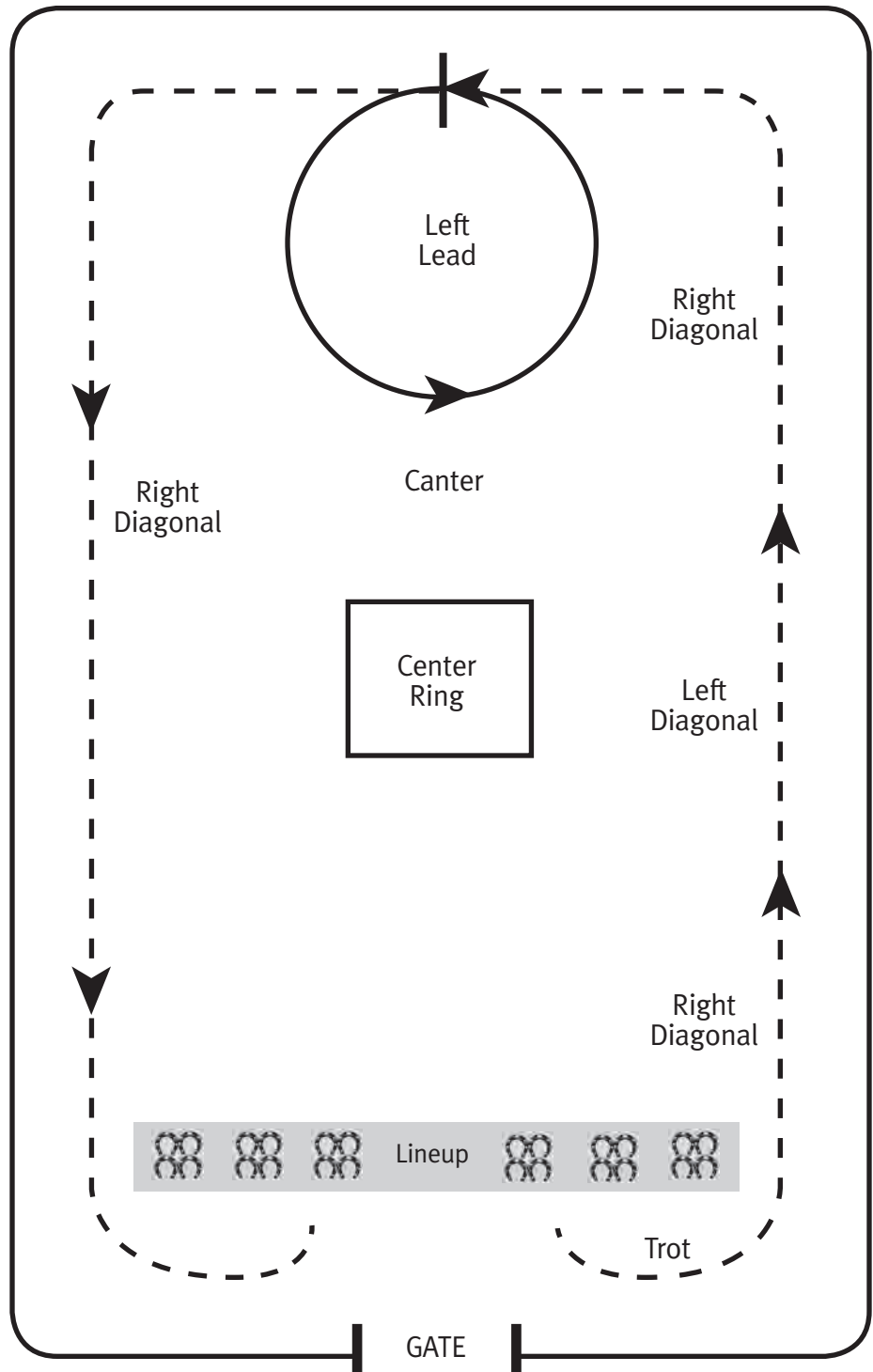

# Saddle Seat

## LEVEL 2 • PATTERN E • Tests 3,6,11

Enter the ring to the right at a trot.  
Trot down the rail showing one change of diagonal. Begin on the left/incorrect diagonal.

Halt at the end of the rail.

Canter on the left lead to the midpoint of the turn and continue cantering executing a two loop serpentine down the center line. Halt.

Trot to the rail on the left diagonal.  
Halt.

Turn left. Trot down the rail on the right diagonal and return to the lineup or exit the ring at the trot.

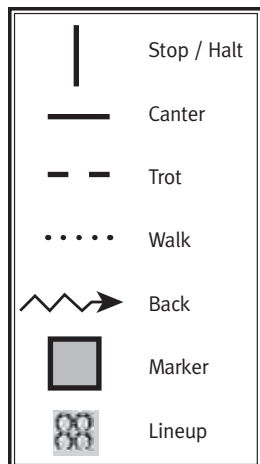

*This pattern may only be used for:*

- 13 & Under
- 14 - 18
- 18 & Under
- 19 & Over

**If used at a Regional or National Show, pattern may not be run from the lineup.**

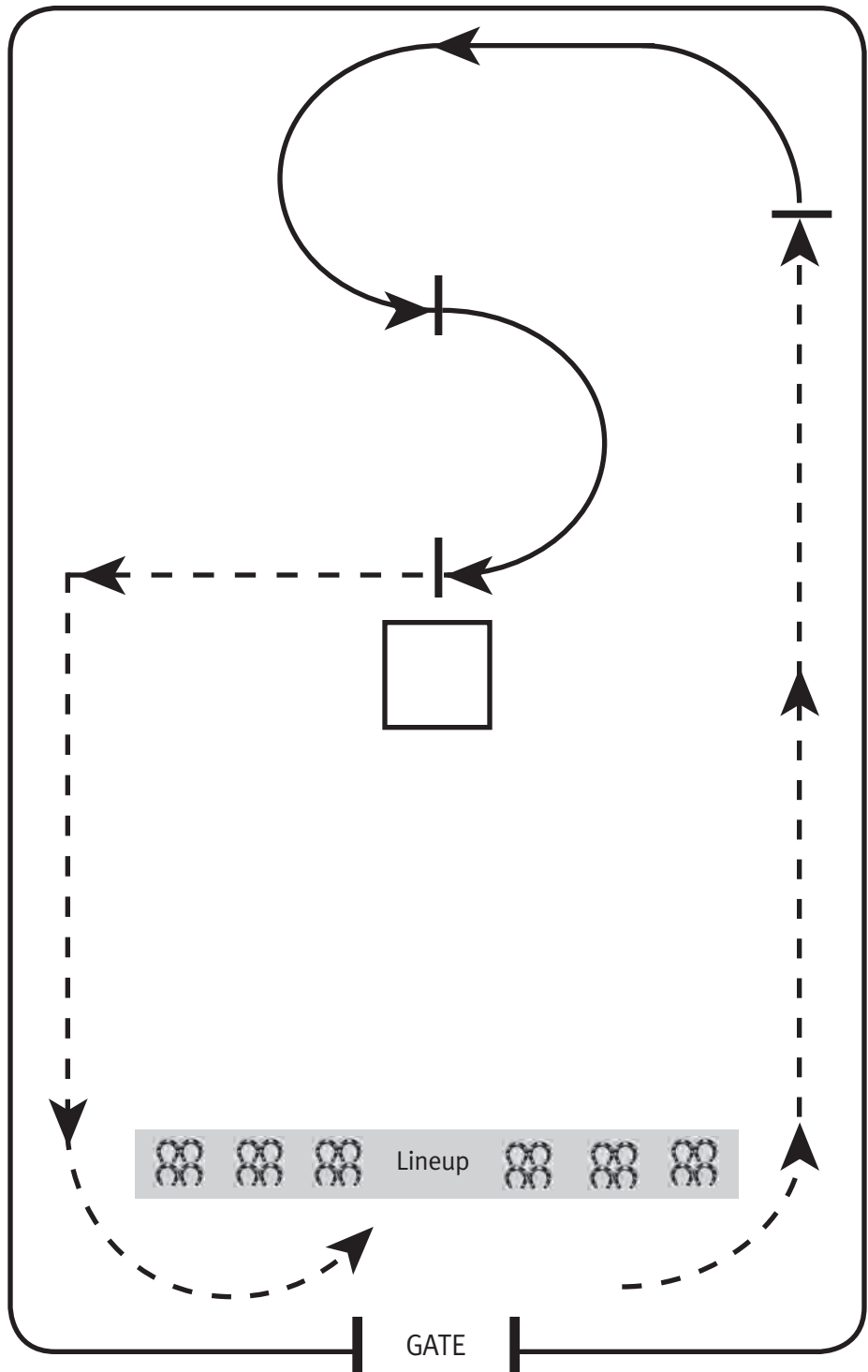

# Showmanship

## LEVEL 1 • PATTERN B

Exhibitors are to complete the pattern on the side of the marker as indicated in the drawing

Be ready at marker A.

Walk from marker A to marker B.

Trot from marker B to marker C.

Stop at marker C and set up for inspection.

When dismissed, back four steps.

Execute a 90-degree turn and trot to marker D as drawn. Stop.

Hesitate for several seconds and then trot to new lineup as directed by the ringmaster or exit as directed by the ringmaster.

- ☐ **In the Ring**— Exhibitors enter arena and remain collectively for the entire class. Exhibitors are to enter the arena at the walk. Trot at the marker and line up at the discretion of the ringmaster.
- ☐ **In and Out of the Ring**— Exhibitors enter arena one at a time and are excused at the completion of their pattern.
- ☐ **At the Gate**— Exhibitors enter arena one at a time and are gathered in arena for final inspection as a collective group.

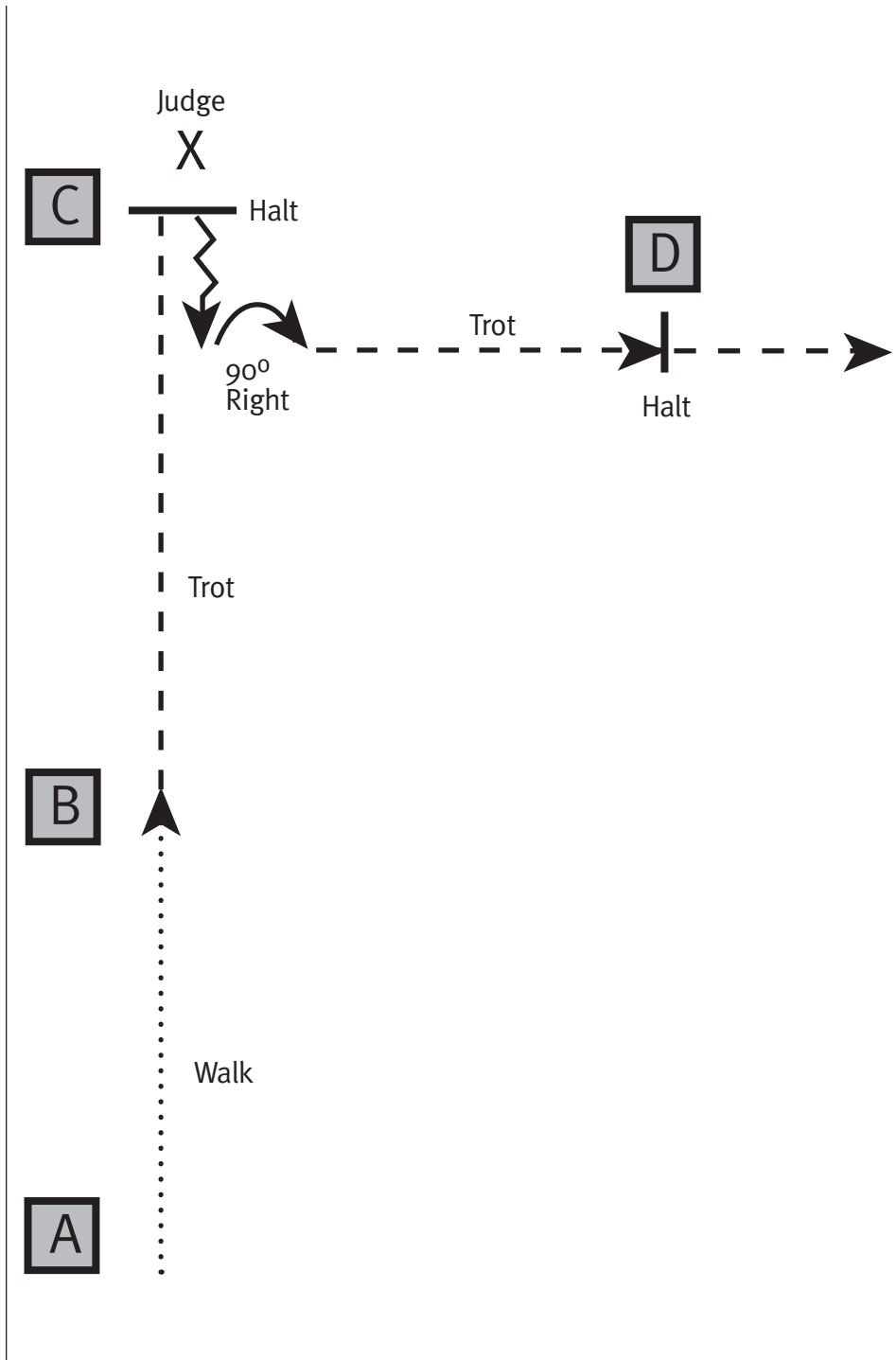

|  |             |
|--|-------------|
|  | Stop / Halt |
|  | Canter      |
|  | Trot        |
|  | Walk        |
|  | Back        |
|  | Marker      |
|  | Lineup      |

- ❑ **In the Ring**— Exhibitors enter arena and remain collectively for the entire class. Exhibitors are to enter the arena at the walk. Trot at the marker and line up at the discretion of the ringmaster.
- ❑ **In and Out of the Ring**— Exhibitors enter arena one at a time and are excused at the completion of their pattern.
- ❑ **At the Gate**— Exhibitors enter arena one at a time and are gathered in arena for final inspection as a collective group.

# Showmanship

## LEVEL 1 • PATTERN C

*Exhibitors are to complete the pattern on the side of the marker as indicated in the drawing*

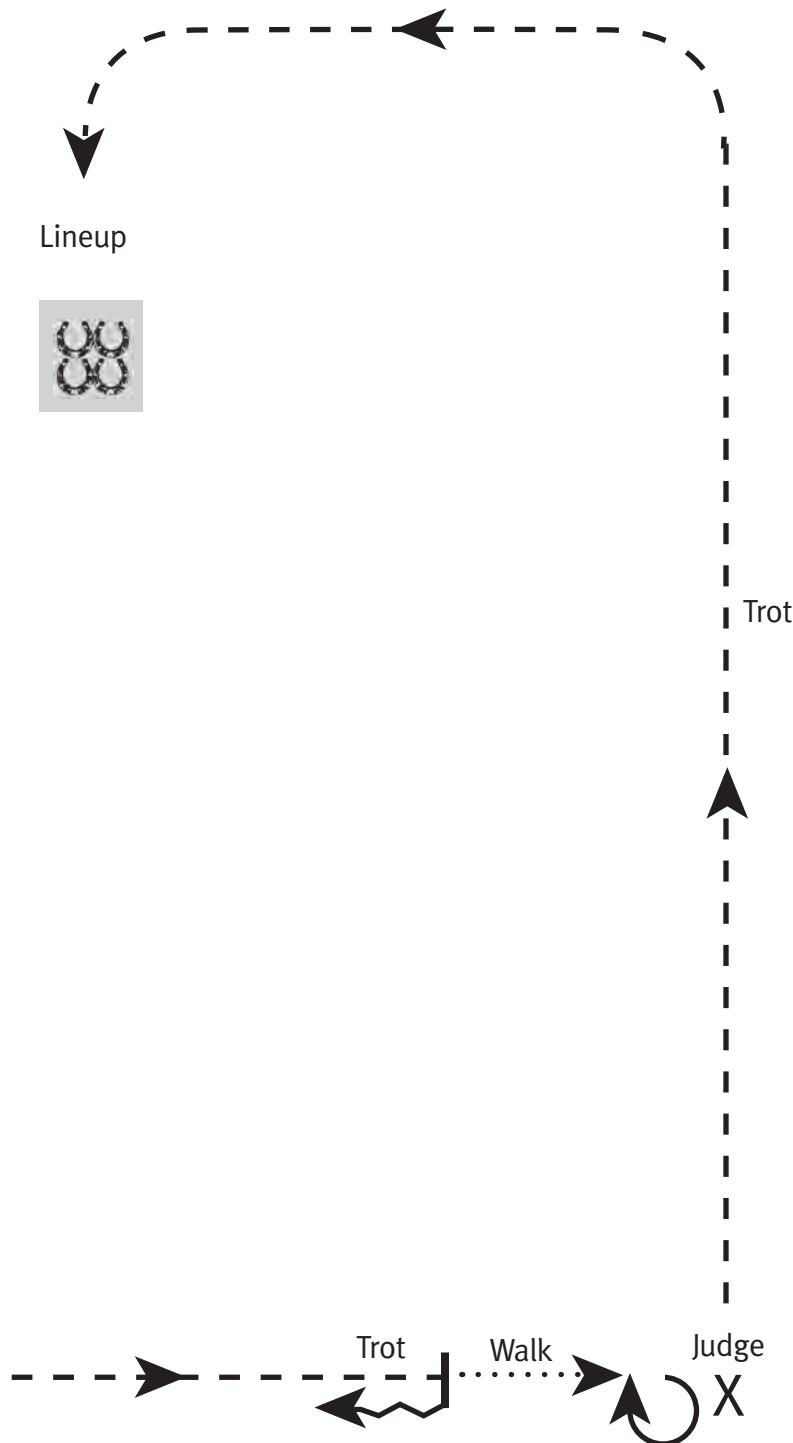

Trot 3/4 way to the judge.

Stop and back four steps.

Walk to the judge and set up for inspection.

When excused, execute a 270-degree turn to the right and trot straight away from the judge.

Return to lineup at the trot or exit as directed by the ringmaster.

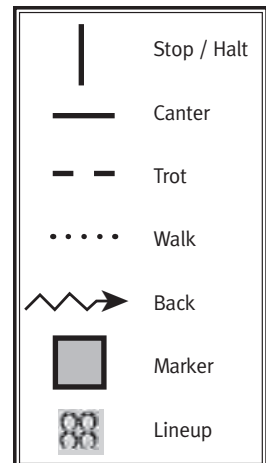



# Showmanship

## LEVEL 1 • PATTERN F

*Exhibitors are to complete the pattern on the side of the marker as indicated in the drawing*

Be ready at marker A.

Walk from marker A to around marker B.

Trot from marker B to the judge.

Stop and set up for inspection.

When dismissed, turn approximately 90-degrees.

Return to lineup at the trot or exit at the direction of the ringmaster.

- ❑ **In the Ring**— Exhibitors enter arena and remain collectively for the entire class. Exhibitors are to enter the arena at the walk. Trot at the marker and line up at the discretion of the ringmaster.
- ❑ **In and Out of the Ring**— Exhibitors enter arena one at a time and are excused at the completion of their pattern.
- ❑ **At the Gate**— Exhibitors enter arena one at a time and are gathered in arena for final inspection as a collective group.

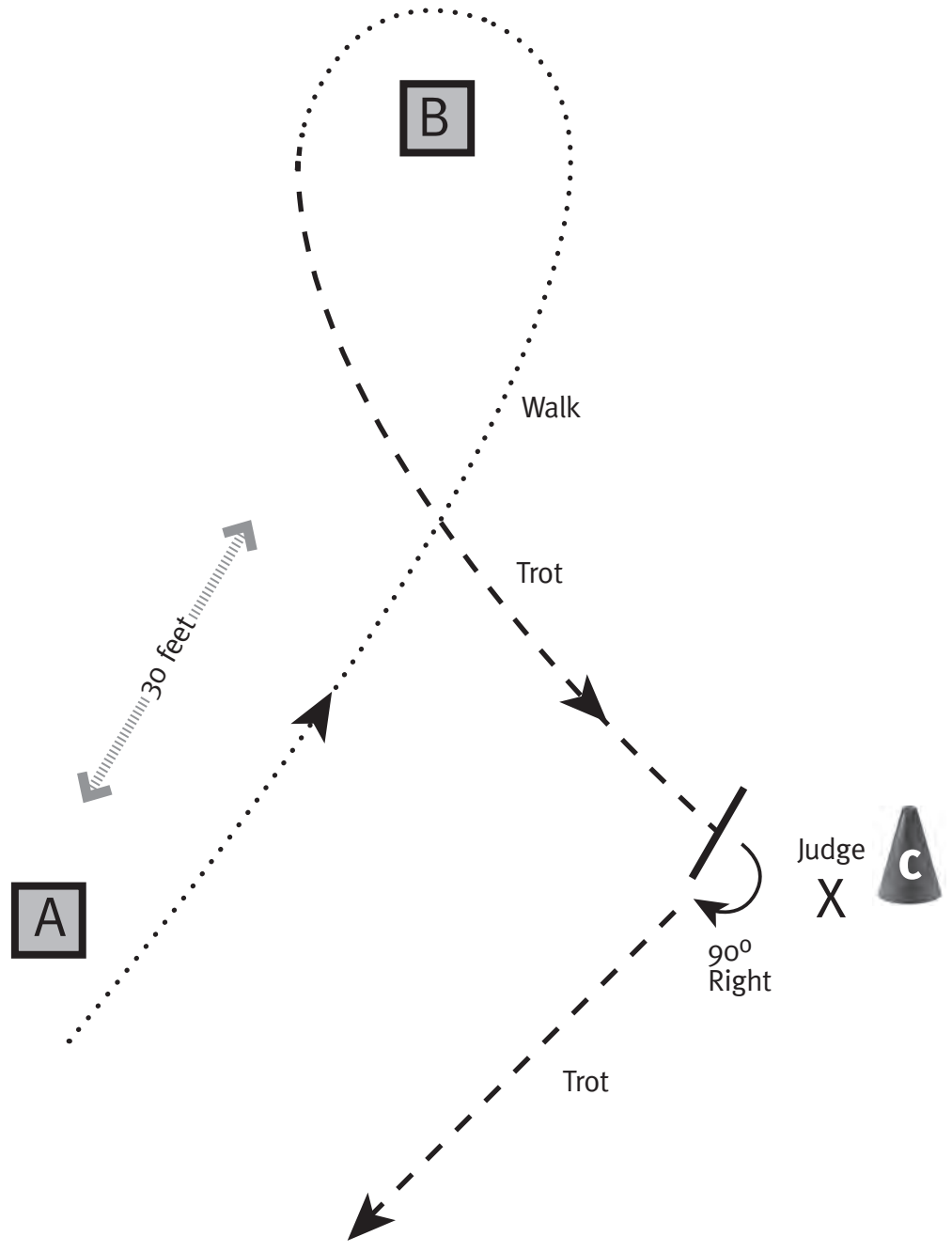
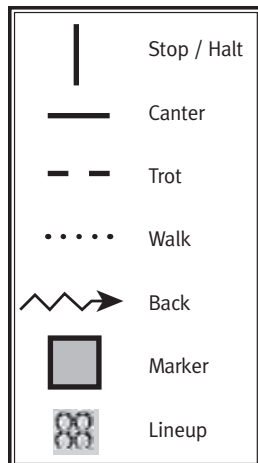

# Showmanship

## LEVEL 1 • PATTERN H

*Exhibitors are to complete the pattern on the side of the marker as indicated in the drawing*

Be ready at marker A.

Back four steps at marker A.

Perform a 180-degree turn.

Walk to the judge and set up for inspection.

When dismissed perform a 90-degree turn and trot to marker B.

Stop at marker B.

Return to lineup at the trot or exit as directed by the ringmaster.

- ❑ **In the Ring**— Exhibitors enter arena and remain collectively for the entire class. Exhibitors are to enter the arena at the walk. Trot at the marker and line up at the discretion of the ringmaster.
- ❑ **In and Out of the Ring**— Exhibitors enter arena one at a time and are excused at the completion of their pattern.
- ❑ **At the Gate**— Exhibitors enter arena one at a time and are gathered in arena for final inspection as a collective group.

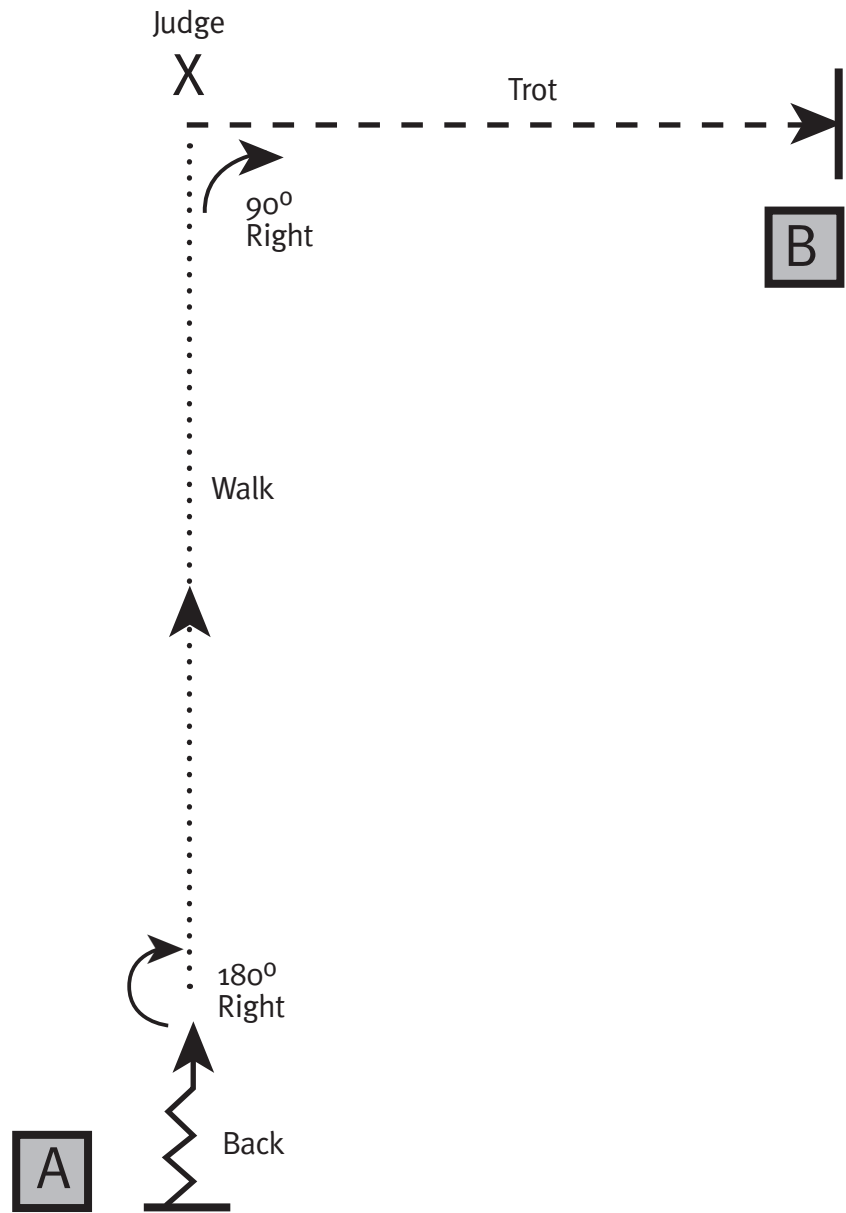
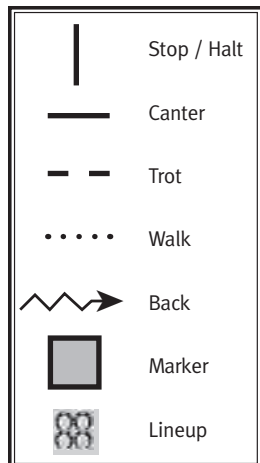

- ❑ **In the Ring**— Exhibitors enter arena and remain collectively for the entire class. Exhibitors are to enter the arena at the walk. Trot at the marker and line up at the discretion of the ringmaster.
- ❑ **In and Out of the Ring**— Exhibitors enter arena one at a time and are excused at the completion of their pattern.
- ❑ **At the Gate**— Exhibitors enter arena one at a time and are gathered in arena for final inspection as a collective group.

# Showmanship

## LEVEL 2 • PATTERN M

*Exhibitors are to complete the pattern on the side of the marker as indicated in the drawing*

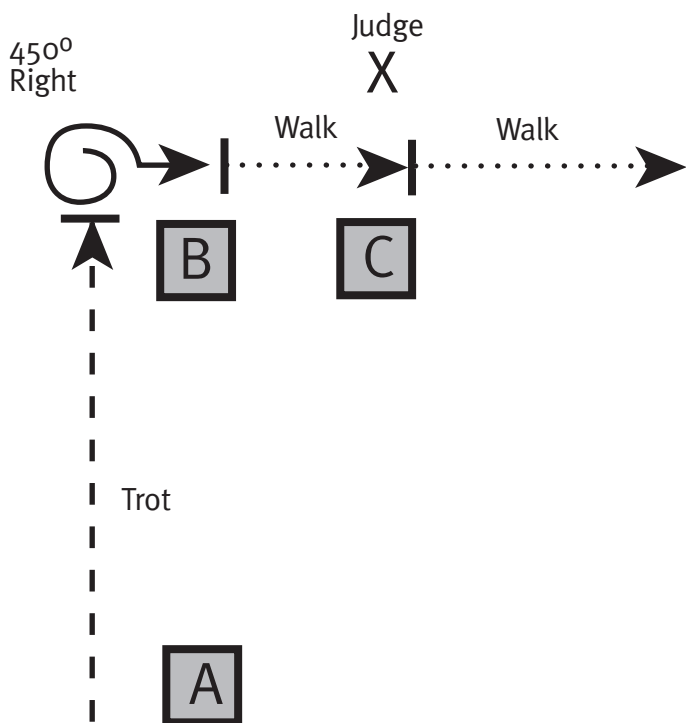

Be ready at marker A.

Trot just past marker B. Stop.

Execute a 450-degree haunch turn to the right. Stop.

Walk to marker C. Stop.

Set up for inspection.

After dismissal, walk into lineup.

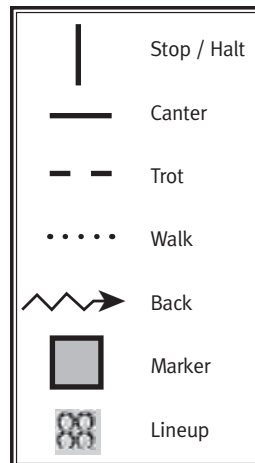

- ❑ **In the Ring**— Exhibitors enter arena and remain collectively for the entire class. Exhibitors are to enter the arena at the walk. Trot at the marker and line up at the discretion of the ringmaster.
- ❑ **In and Out of the Ring**— Exhibitors enter arena one at a time and are excused at the completion of their pattern.
- ❑ **At the Gate**— Exhibitors enter arena one at a time and are gathered in arena for final inspection as a collective group.

# Showmanship

## LEVEL 2 • PATTERN T

*Exhibitors are to complete the pattern on the side of the marker as indicated in the drawing*

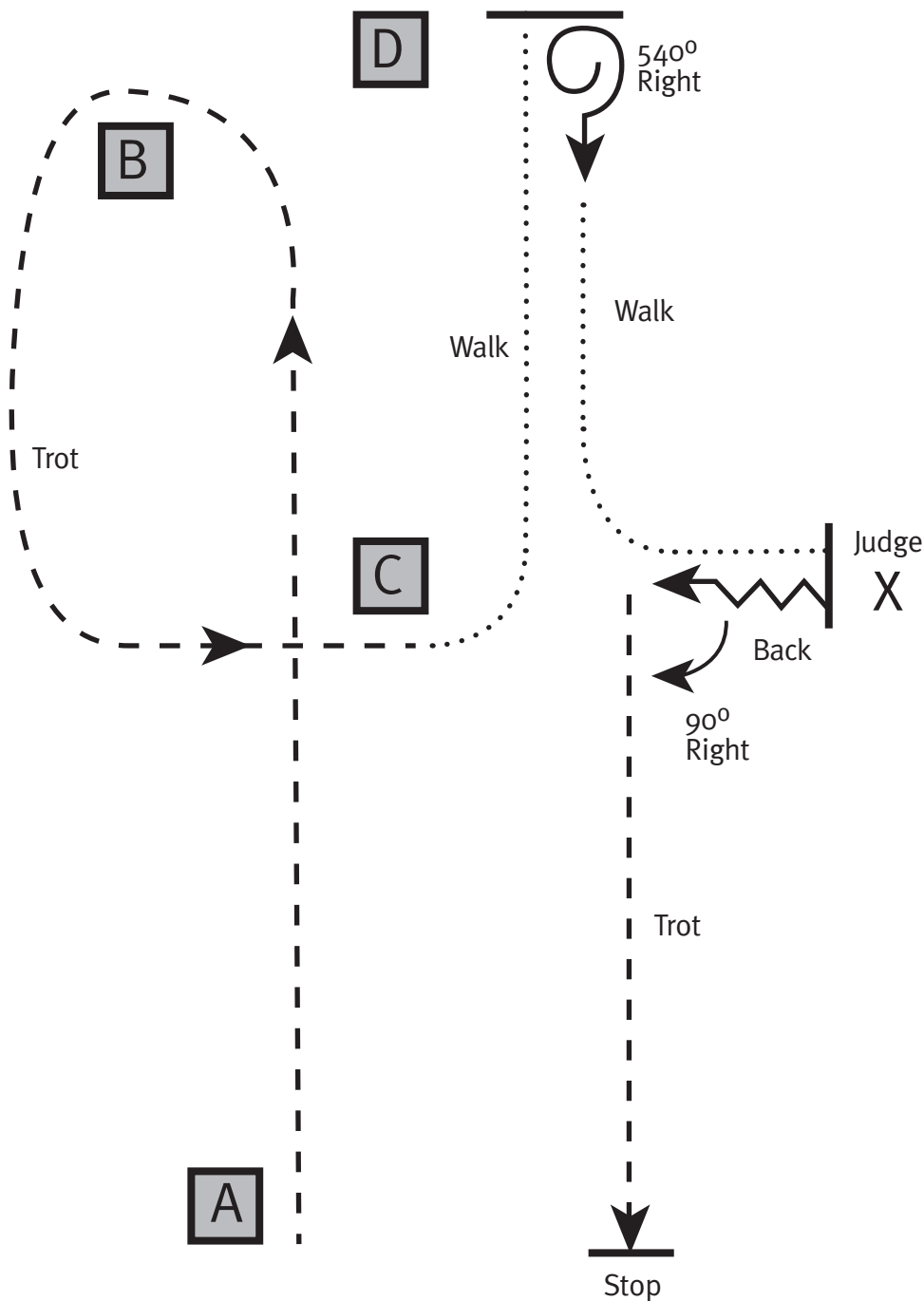

- Be ready at marker A.
- Trot around marker B and to marker C.
- Walk curve directly to marker D.
- Stop and execute 540-degree turn.
- Walk curve to the judge.
- Stop and set up for inspection.
- When dismissed, back four steps, execute 90-degree turn.
- Trot away as drawn until even with marker A.
- Stop.
- Return to lineup at trot or exit as instructed by the ringmaster.

|  |             |
|--|-------------|
|  | Stop / Halt |
|  | Canter      |
|  | Trot        |
|  | Walk        |
|  | Back        |
|  | Marker      |
|  | Lineup      |

# RANCH RIDING - PATTERN 9

## LEGEND

|         |               |
|---------|---------------|
| .....   | Walk          |
| ....    | Extended Walk |
| - - -   | Trot          |
| - - - - | Extended Trot |
| — — —   | Lope          |
| — — — — | Extended Lope |
| ////    | Back          |
| \\      | Lead Change   |

Note: The drawn description of this pattern is only intended for the general depiction of the pattern. Exhibitors should utilize the arena space to best exhibit their horses.

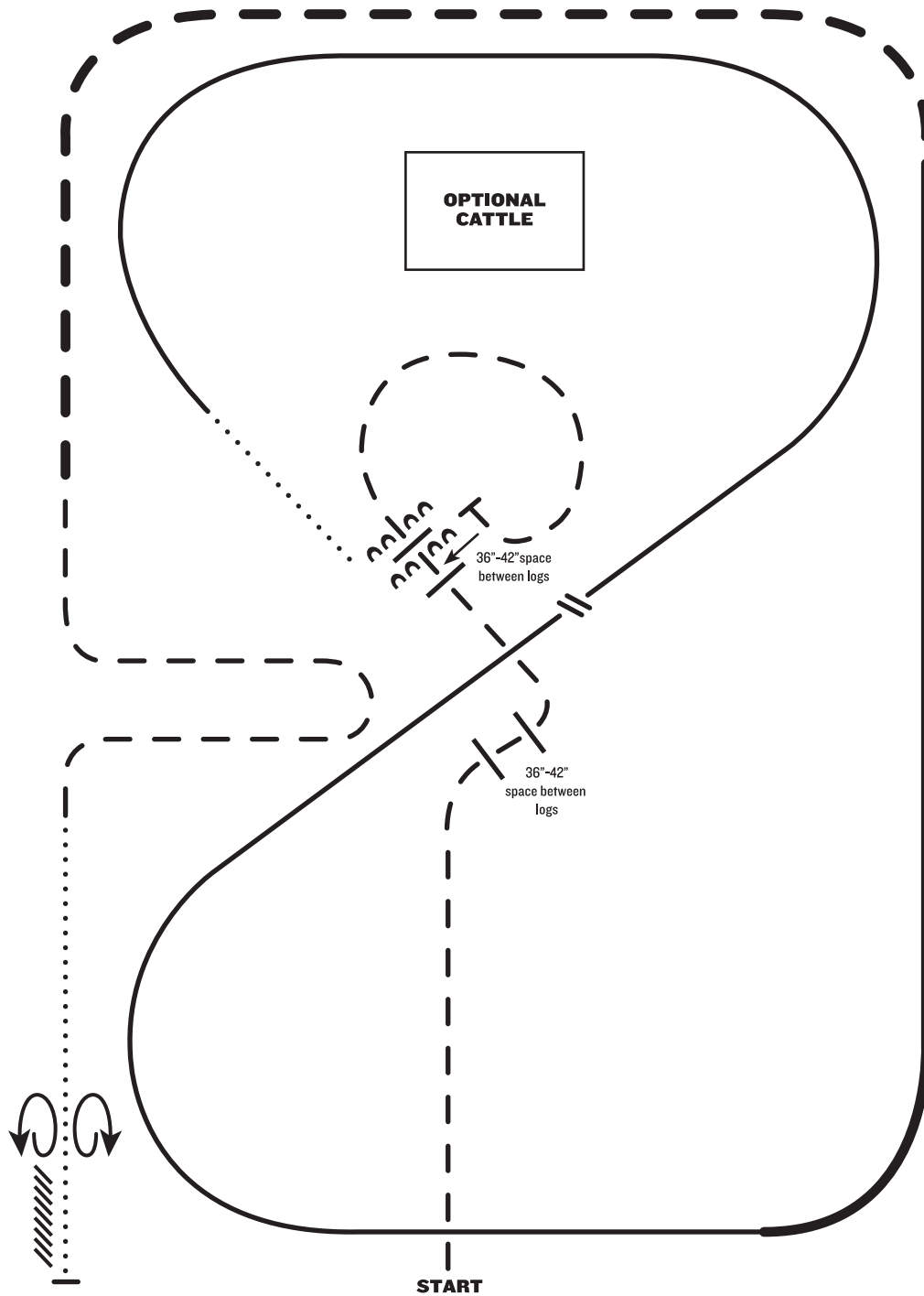

1. Trot
2. Trot over two sets of logs
3. Trot circle, stop and side pass left over log
4. Walk
5. Lope right lead
6. Change leads (simple or flying)
7. Lope left lead
8. Extended lope left lead
9. Extended trot
10. Trot
11. Walk
12. Stop and back
13. 360° turn each direction (either direction 1st) (L-R or R-L)

REGION 4 AHA CHAMPIONSHIPS 2024

JUNE 16 - 22, 2024

455 REGION 4 HA/AA Ranch Horse Riding Pattern#

499 REGION 4 Arabian Ranch Horse Riding Pattern#

# RANCH RIDING - PATTERN 12

## LEGEND

|         |               |
|---------|---------------|
| .....   | Walk          |
| ....    | Extended Walk |
| - - -   | Trot          |
| - - - - | Extended Trot |
| — — —   | Lope          |
| — — — — | Extended Lope |
| ////    | Back          |
| \\      | Lead Change   |

Note: The drawn description of this pattern is only intended for the general depiction of the pattern. Exhibitors should utilize the arena space to best exhibit their horses.

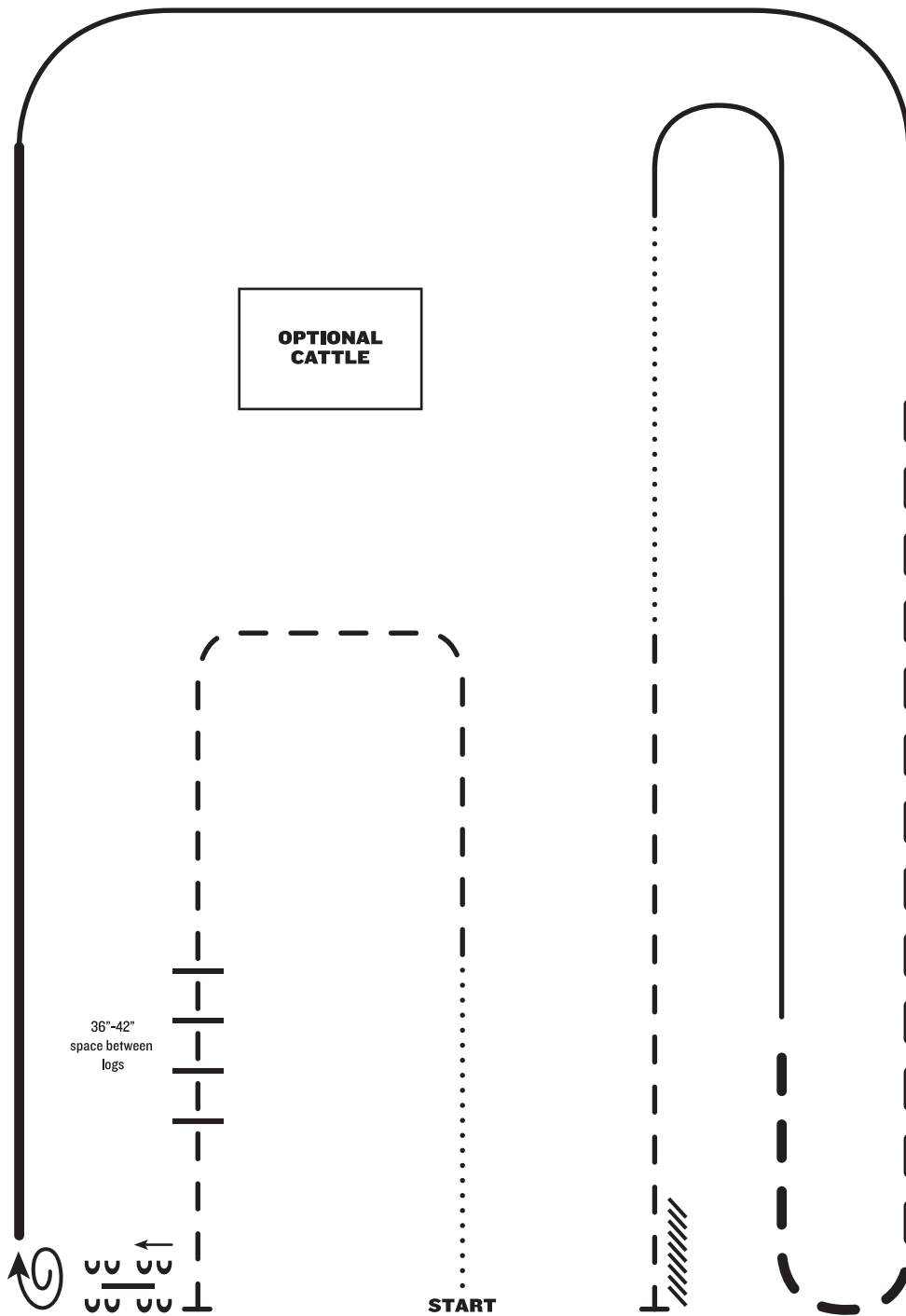

1. Walk
2. Trot
3. Trot over logs, stop
4. Side pass right over log
5. 1 1/2 turn right
6. Extended lope right lead
7. Lope right lead
8. Extended trot
9. Lope left lead
10. Walk
11. Trot
12. Stop and back

### REGION 4 AHA CHAMPIONSHIPS 2024 JUNE 16 - 22, 2024

- |     |   |
|-----|---|
| 538 | REGION 4 HA/AA Ranch Horse Riding AATR 19-49 Pattern#       |
| 539 | REGION 4 Arabian Ranch Horse Riding AATR 19-49 Pattern#     |
| 540 | REGION 4 HA/AA Ranch Horse Riding AATR 50 & Over Pattern#   |
| 541 | REGION 4 Arabian Ranch Horse Riding AATR 50 & Over Pattern# |
| 542 | REGION 4 HA/AA Ranch Horse Riding JTR Pattern#              |
| 543 | REGION 4 Arabian Ranch Horse Riding JTR Pattern#            |

453 REGION 4 Arabian Ranch Horse Riding Junior Horse Pattern#

454 REGION 4 Arabian Ranch Horse Riding Futurity ★ Pattern#

500 REGION 4 HA/AA Ranch Horse Riding Junior Horse Pattern#

501 REGION 4 HA/AA Ranch Horse Riding Futurity ★ Pattern#

**RANCH RIDING - PATTERN 15**

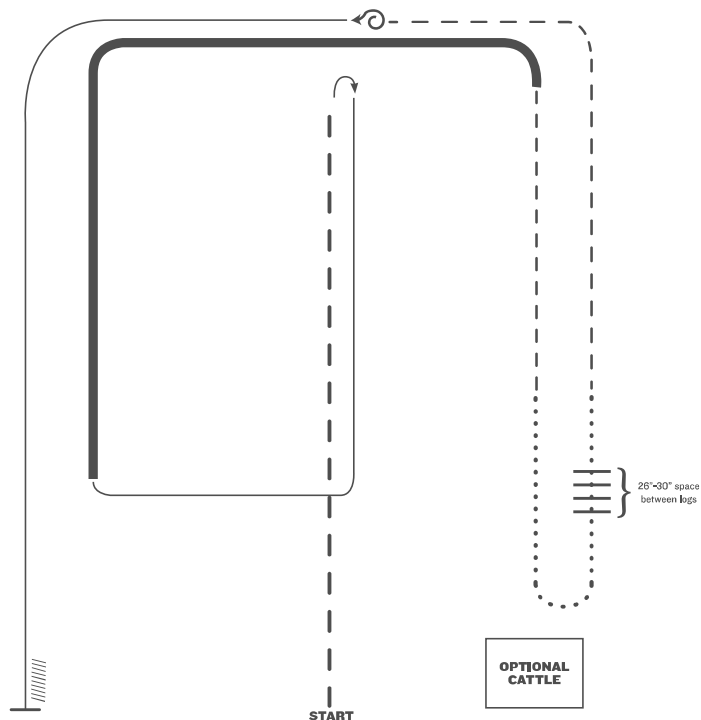

1. Extended trot
2. Stop, rollback right
3. Lope right lead
4. Extended lope (right lead)
5. Trot
6. Walk
7. Walk over logs
8. Walk
9. Trot
10. Stop, 360 left
11. Lope left lead
12. Stop and back

Note: The drawn description of this pattern is only intended for the general depiction of the pattern. Exhibitors should utilize the arena space to best exhibit their horses.

## Pattern 2

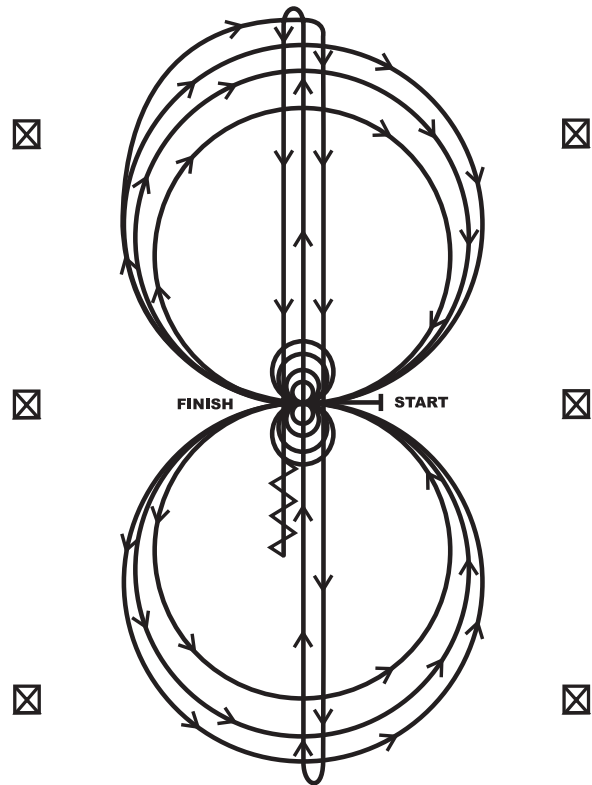

## Pattern 2

Horses may walk or jog to the center of arena. (To assist with the show schedule, show management may require that horses be jogged to center. Show management is responsible for posting this requirement.) Horses must walk or stop prior to starting pattern. Beginning at the center of the arena facing the left wall or fence.

1. Beginning on the right lead, complete three circles to the right: the first circle small and slow; the next two circles large and fast. Change leads at the center of the arena.
2. Complete three circles to the left: the first circle small and slow; the next two circles large and fast. Change leads at the center of the arena.
3. Continue around previous circle to the right. At the top of the circle, run down the middle to the far end of the arena past the end marker and do a right rollback—no hesitation.
4. Run up the middle to the opposite end of the arena past the end marker and do a left rollback—no hesitation.
5. Run past the center marker and do a sliding stop. Back up to the center of the arena or at least ten feet (three meters). Hesitate.
6. Complete four spins to the right. Hesitate.
7. Complete four spins to the left. Hesitate to demonstrate the completion of the pattern.

### REGION 4 AHA CHAMPIONSHIPS 2024 JUNE 16 - 22, 2024

- 513 REGION 4 Arabian Reining Horse Pattern#  
525 REGION 4 HA/AA Reining Horse Pattern#



### Pattern 3

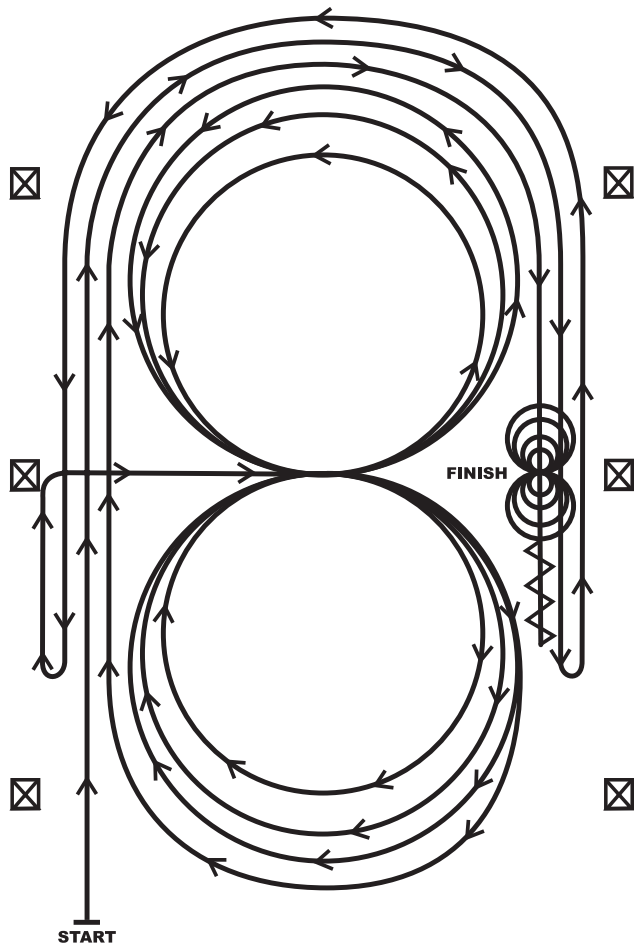

### Pattern 3

1. Beginning, lope straight up the left side of the arena, circle the top end of the arena, and staying at least twenty feet (six meters) from the walls or fence, run straight down the opposite or right side of the arena past the center marker and do a left rollback—no hesitation.

2. Continue straight up the right side of the arena circle back around the top of the arena, and staying at least twenty feet (six meters) from the walls or fence, run straight down the left side of the arena past the center marker and do a right rollback—no hesitation.

3. Continue up the left side of the arena to the center marker. At the center marker, the horse should be on the right lead. Guide the horse to the center of the arena on the right lead and complete three circles to the right: the first two circles large and fast; the third circle small and slow. Change leads at the center of the arena.

4. Complete three circles to the left: the first two circles large and fast; the third circle small and slow. Change leads in the center of the arena.

5. Begin a large circle to the right but do not close this circle. Continue up the left side of the arena, circle the top of the arena, and staying at least twenty feet (six meters) from the walls or fence, run straight down the opposite or right side of the arena past the center marker and do a sliding stop. Back up at least ten feet (three meters). Hesitate.

6. Complete four spins to the right. Hesitate.

7. Complete four spins to the left. Hesitate to demonstrate completion of the pattern.

## REGION 4 AHA CHAMPIONSHIPS 2024

JUNE 16 - 22, 2024

- 442 REGION 4 Arabian Reining Horse AAOTR Pattern #
- 443 REGION 4 Arabian Reining Horse Intermediate Non-Pro AATR
- 444 REGION 4 Arabian Reining Horse Limited Non-Pro AATR
- 445 REGION 4 Arabian Reining Horse Primetime Non-Pro AATR
- 446 REGION 4 Arabian Reining Horse Rookie Non-Pro AATR
- 492 REGION 4 Arabian Reining Horse JTR 18 & Under Pattern#

- 494 REGION 4 HA/AA Reining Horse AAOTR \$\$ Pattern#
- 495 REGION 4 HA/AA Reining Horse Intermediate Non-Pro AATR
- 496 REGION 4 HA/AA Reining Horse Limited Non-Pro AATR
- 497 REGION 4 HA/AA Reining Horse Primetime Non-Pro AATR
- 498 REGION 4 HA/AA Reining Horse Rookie Non-Pro AATR
- 493 REGION 4 HA/AA Reining Horse JTR 18 & Under Pattern#

# PATTERN

## 4

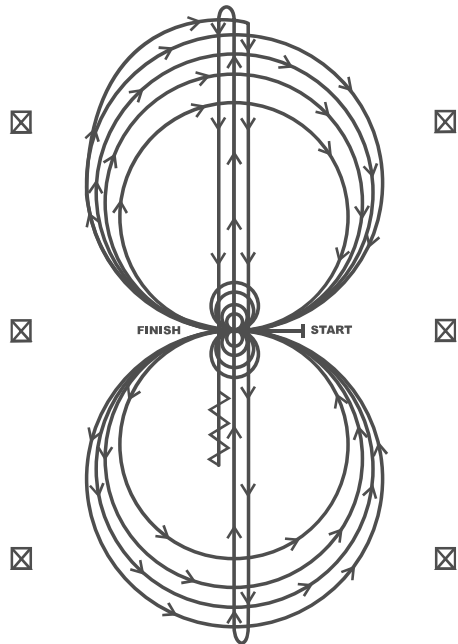

REGION 4 AHA CHAMPIONSHIP SHOW  
JUNE 16 - 22, 2024      CALL JUDGE: MCGINNIS  
154    HA/AA Reining Pattern#4

# PATTERN

## 4

Horses may walk or jog to the center of the arena. Horses must walk or stop prior to starting pattern. Beginning at the center of the arena facing the left wall or fence.

1. Beginning on the right lead, complete three circles to the right: the first two large and fast; the third circle small and slow. Stop at the center of the arena. Hesitate.
2. Complete four spins to the right. Hesitate.
3. Beginning on the left lead, complete three circles to the left: the first two circles large and fast; the third circle small and slow. Stop at the center of the arena. Hesitate.
4. Complete four spins to the left. Hesitate.
5. Beginning on the right lead, run a large fast circle to the right, change leads at the center of the arena, run a large fast circle to the left, and change leads at the center of the arena. (Figure 8)
6. Continue around previous circle to the right. At the top of the circle, run down the middle to the far end of the arena past the end marker and do a right rollback—no hesitation.
7. Run up the middle to the opposite end of the arena past the end marker and do a left rollback—no hesitation.
8. Run past the center marker and do a sliding stop. Back up to the center of the arena or at least ten feet (three meters). Hesitate to demonstrate completion of the pattern.

## Pattern 5

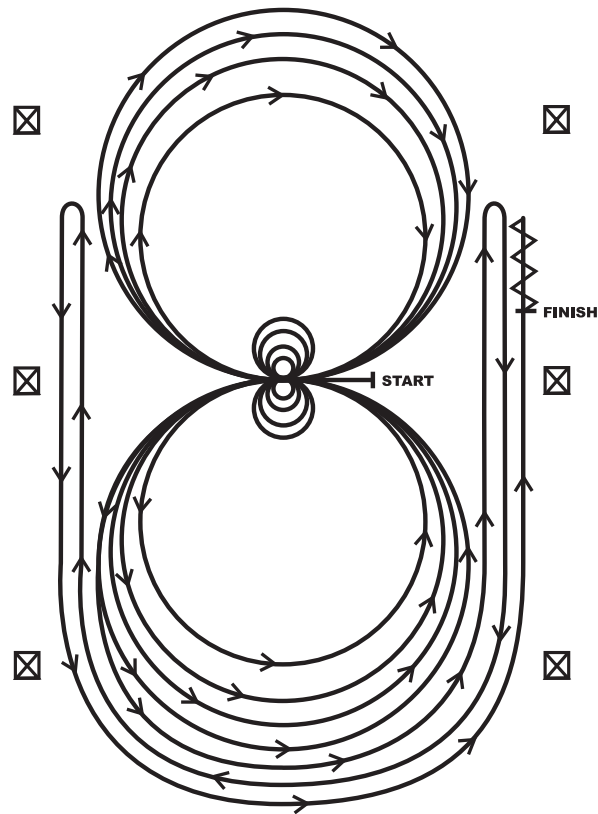

## Pattern 5

Horses may walk or jog to the center of arena. (To assist with the show schedule, show management may require that horses be jogged to center. Show management is responsible for posting this requirement.) Horses must walk or stop prior to starting pattern. Beginning at the center of the arena facing the left wall or fence.

1. Beginning on the left lead, complete three circles to the left: the first two circles large and fast; the third circle small and slow. Stop at the center of the arena. Hesitate.
2. Complete four spins to the left. Hesitate.
3. Beginning on the right lead, complete three circles to the right: the first two circles large and fast; the third circle small and slow. Stop at the center of the arena. Hesitate.
4. Complete four spins to the right. Hesitate.
5. Beginning on the left lead, run a large fast circle to the left, change leads at the center of the arena, run a large fast circle to the right, and change leads at the center of the arena. (Figure 8)
6. Continue around previous circle to the left but do not close this circle. Run up the right side of the arena past the center marker and do a right rollback at least twenty feet (six meters) from the wall or fence—no hesitation.
7. Continue around previous circle but do not close this circle. Run up the left side of the arena past the center marker and do a left rollback at least twenty feet (six meters) from the wall or fence—no hesitation.
8. Continue back around previous circle but do not close this circle. Run up the right side of the arena past the center marker and do a sliding stop at least twenty feet (six meters) from the wall or fence. Back up at least ten feet (three meters). Hesitate to demonstrate completion of the pattern.

## REGION 4 AHA CHAMPIONSHIPS 2024

JUNE 16 - 22, 2024

- 451 REGION 4 Arabian Reining Horse Futurity ★ Pattern #5
- 452 REGION 4 Arabian Reining Horse Junior Horse \$\$ Pattern #5
- 470 REGION 4 HA/AA Reining Horse Futurity ★ Pattern # 5
- 471 REGION 4 HA/AA Reining Junior Horse \$\$ Pattern # 5

### Pattern 11

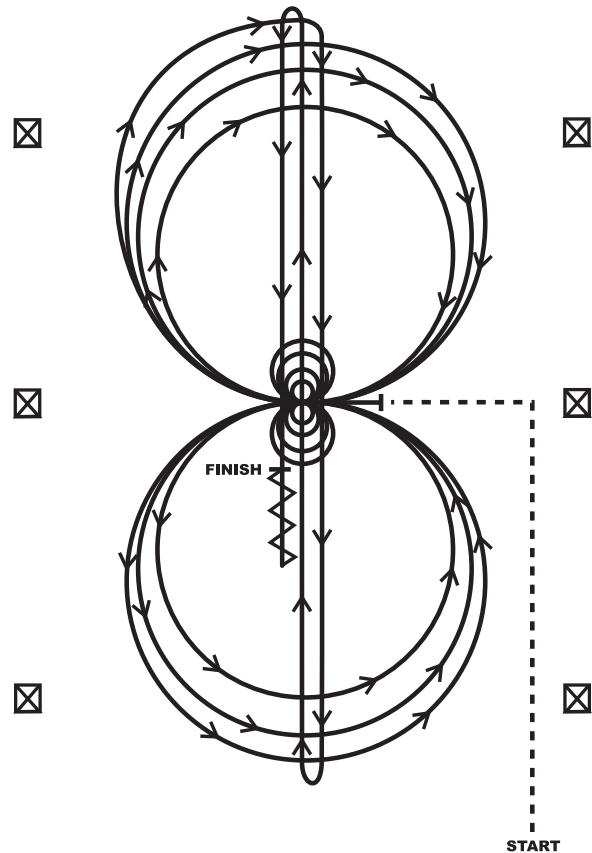

### Pattern 11

Horses must jog to the center of the arena (see Judges Guide for maneuver description). Horses must walk or stop prior to starting the pattern. Beginning at the center of the arena facing the left wall or fence.

1. Complete four spins to the left. Hesitate.
2. Complete four spins to the right. Hesitate.
3. Beginning on the right lead complete three circles to the right; the first circle small and slow; the next two circles large and fast. Change leads at the center of the arena.
4. Complete three circles to the left; the first circle small and slow; the next two circles large and fast. Change leads at the center of the arena.
5. Begin a large circle to the right, but do not close this circle. Run down the center of the arena past the end marker and do a right rollback—no hesitation.
6. Run up the middle to the opposite end of the arena past the end marker and do a left rollback—no hesitation.
7. Run past the center marker and do a sliding stop. Back up to the center of the arena or at least ten feet (three meters). Hesitate to demonstrate completion of the pattern.

### REGION 4 AHA CHAMPIONSHIPS 2024 JUNE 16 - 22, 2024

- 447 REGION 4 Reining Seat Equitation AATR Pattern #11
- 448 REGION 4 Reining Seat Equitation JTR 15-18 Pattern #11
- 449 REGION 4 Reining Seat Equitation JTR 14 & Under Pattern #11

### Pattern A

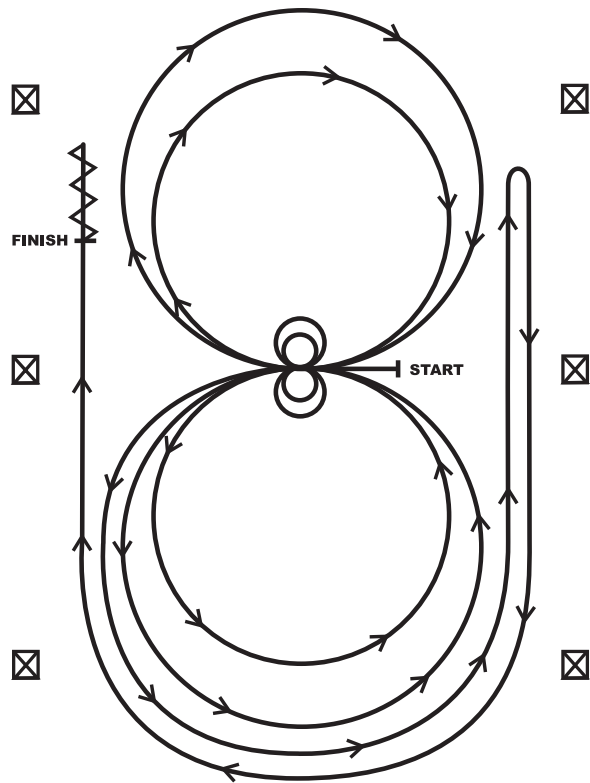

### Pattern A

To be used for the Youth 10 & Under Short Stirrup and Para-Reining only.

Horses may walk or jog to the center of the arena. (To assist with the show schedule, show management may require that horses be jogged to center. Show management is responsible for posting this requirement.) Horses must walk or stop prior to starting the pattern. Beginning at the center of the arena facing the left wall or fence.

1. Beginning on the left lead, complete two circles to the left. Stop at the center of the arena. Hesitate.
2. Complete two spins to the left. Hesitate.
3. Beginning on the right lead complete two circles to the right. Stop at the center of the arena. Hesitate.
4. Complete two spins to the right. Hesitate.
5. Beginning on the left lead, go around the end of the arena, run down the right side of the arena past center marker, stop and roll back right.
6. Continue around the end of the arena to run down the left side of the arena past the center marker. Stop. Back up. Hesitate to demonstrate completion of the pattern.

See the Judges' Guide for a summary of other allowances made in the *Handbook*.

REGION 4 AHA CHAMPIONSHIP SHOW  
JUNE 16 - 22, 2024 CALL JUDGE: BRADLEY  
450 REGION 4 A/HA/AA Short Stirrup Reining 10 & Under Pattern#A

REGION 4 AHA CHAMPIONSHIPS 2024

JUNE 16 - 22, 2024

404 REGION 4 Arabian Limited Reined Cow Horse ATR (C3) Pattern#5

405 REGION 4 HA/AA Limited Reined Cow Horse ATR (C3) Pattern#5

408 REGION 4 Arabian Reined Cow Horse (C2) Pattern#5

409 REGION 4 HA/AA Reined Cow Horse (C2) Pattern#5

PATTERN 5

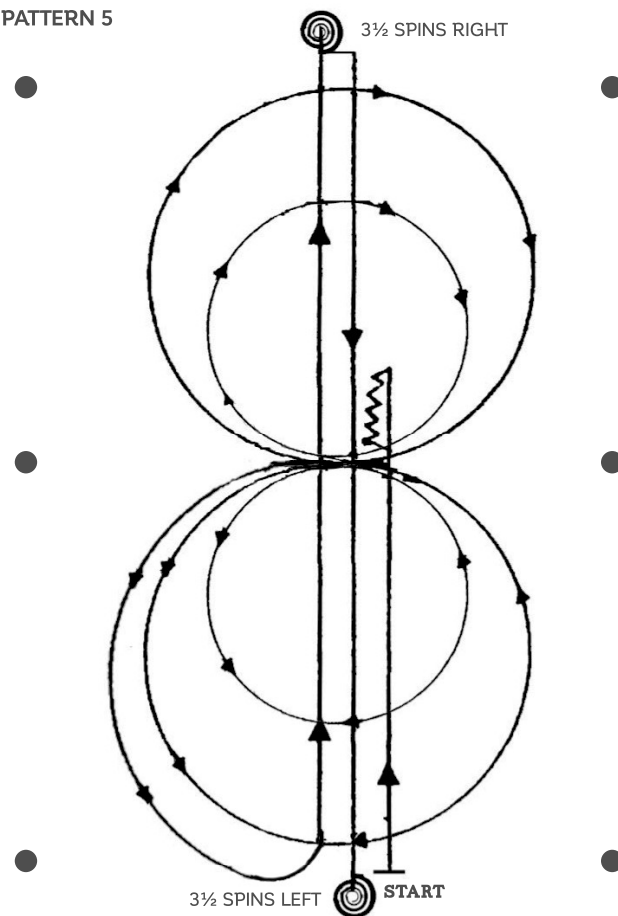

This pattern works best when the exhibitor and cattle enter from the same end of arena.

1. Start at end of arena. Run past center marker, stop, and back at least 10 feet. 1/4 turn to left.
2. Complete two circles to left. The first circle large and fast, the second circle small and slow. Change leads at the center of the arena.
3. Complete two circles to the right. The first circle small and slow, the second circle large and fast. Change leads at the center of the arena.
4. Continue around end of arena without breaking gait or changing leads, run down center of arena past end marker, execute a square sliding stop.
5. Complete 3½ spins to the right.
6. Run down center of arena past end marker, execute a square sliding stop.
7. Complete 3½ spins to the left. Hesitate to complete pattern.

**PATTERN 7**

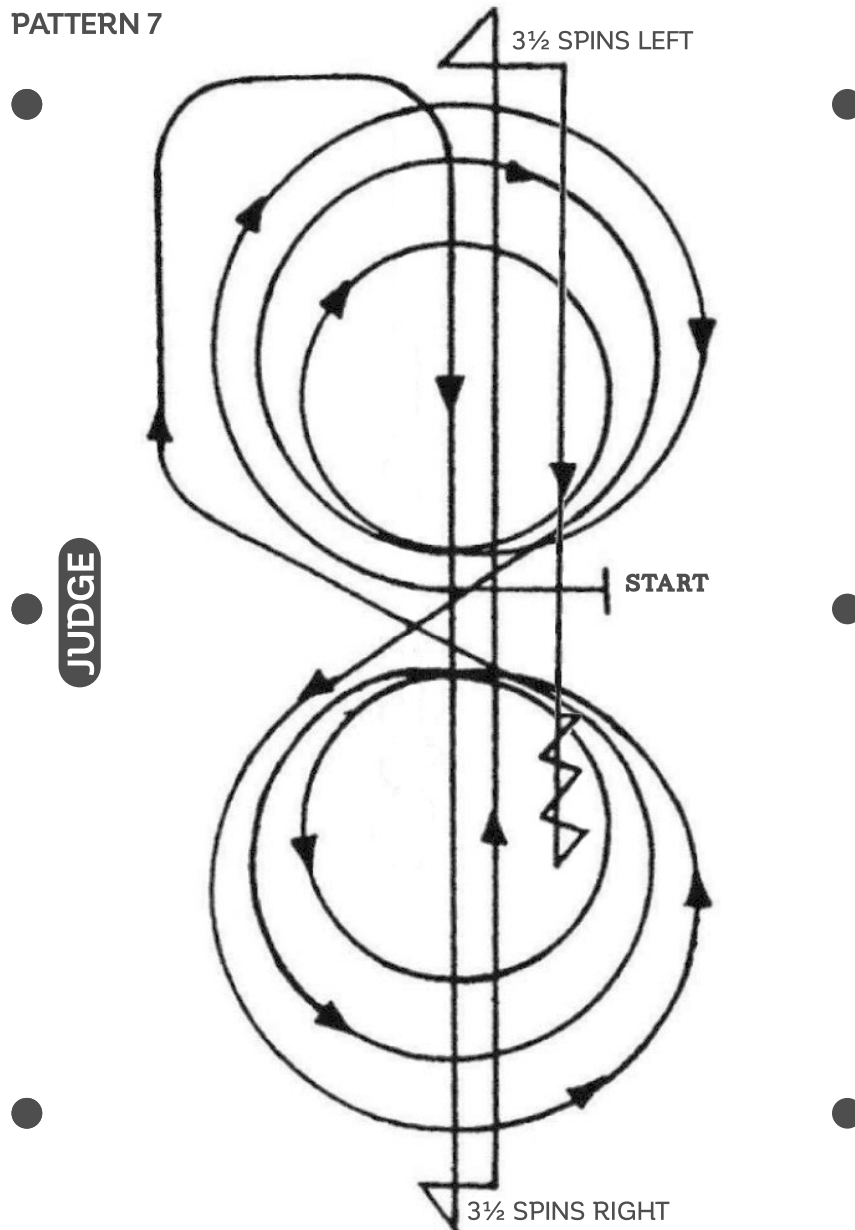

Trot to center of arena, stop. Start pattern facing towards judge.

1. Beginning on right lead and complete three circles, the first large and fast, the second small and slow, the third large and fast. Change leads to the left.
2. Complete three circles, the first large and fast, the second small and slow, the third, large and fast. Change leads to the right.
3. Continue loping around end of arena without breaking gait or changing leads. Run down center of arena, past end marker and come to a sliding stop.
4. Complete 3½ spins to the right.
5. Run down center of arena past end marker come to sliding stop.
6. Complete 3½ spins to the left.
7. Run past center marker come to sliding stop. Back up at least 10 feet. Hesitate to complete pattern.

\*This pattern may be used as a lope in pattern, please refer to rule 20.6.

**PATTERN 11**

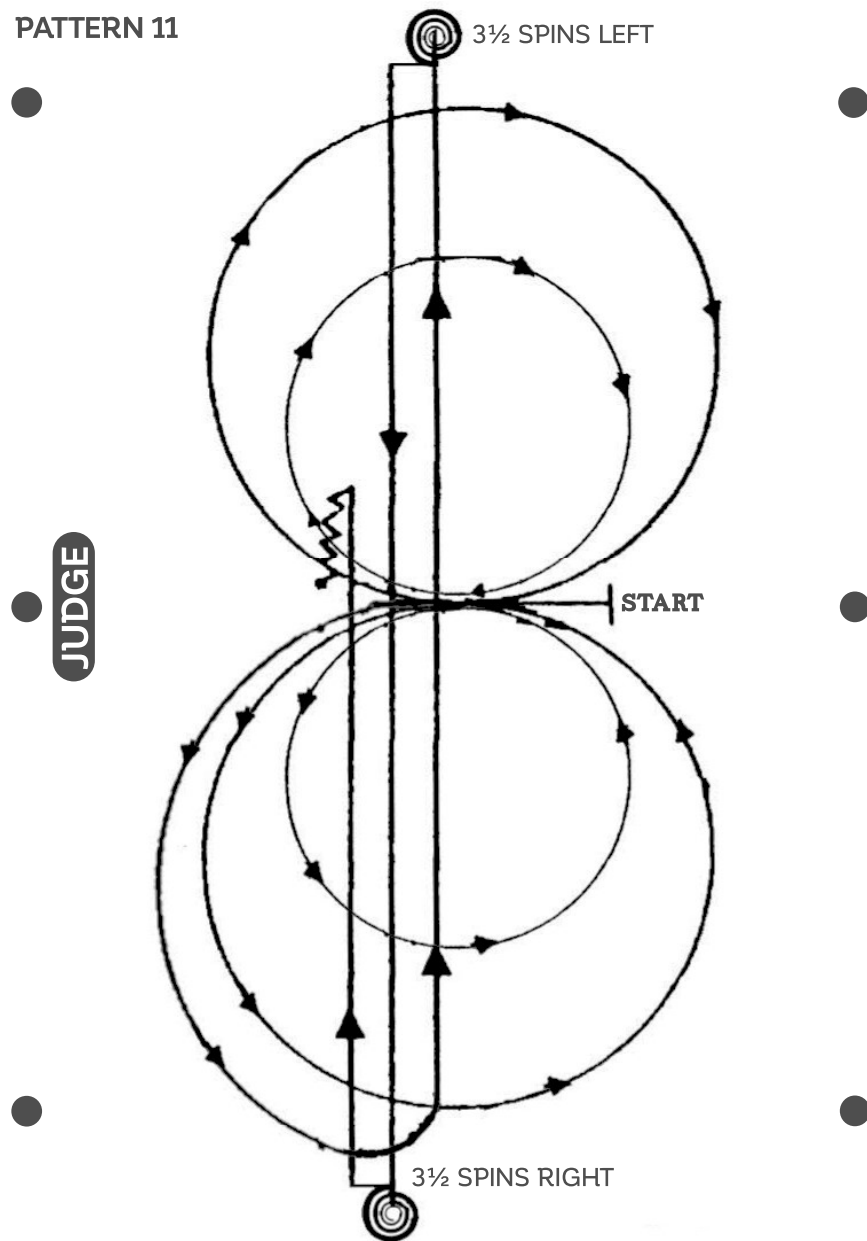

Trot to center of arena, stop. Start pattern facing towards judge.

1. Beginning on the left lead complete two circles to the left, the first circle large and fast, and the second circle small and slow. Change leads at the center of the arena.
2. Complete two circles to the right, the first large and fast, the second small and slow. Change leads at the center of the arena.
3. Continue around end of arena without breaking gait or changing leads, run down center of the arena past the end marker, execute a square sliding stop.
4. Complete  $3\frac{1}{2}$  spins to the left.
5. Run down center of arena past end marker, execute a square sliding stop.
6. Complete  $3\frac{1}{2}$  spins to the right.
7. Run down center of arena past center marker, execute a square sliding stop. Back at least 10 feet. Hesitate to complete pattern.

\*This pattern may be used as a lope in pattern. Please refer to rule 20.6.