



RoboLabs

Incredible machines for fastfood & funfood

TECHNICAL MANUAL ROBOSUGAR TWIN AUTO 20 (CPA-20)



ASSEMBLING AND INSTALLATION



Scan QR code to see assembling process video.

Dimensions (all in mm):

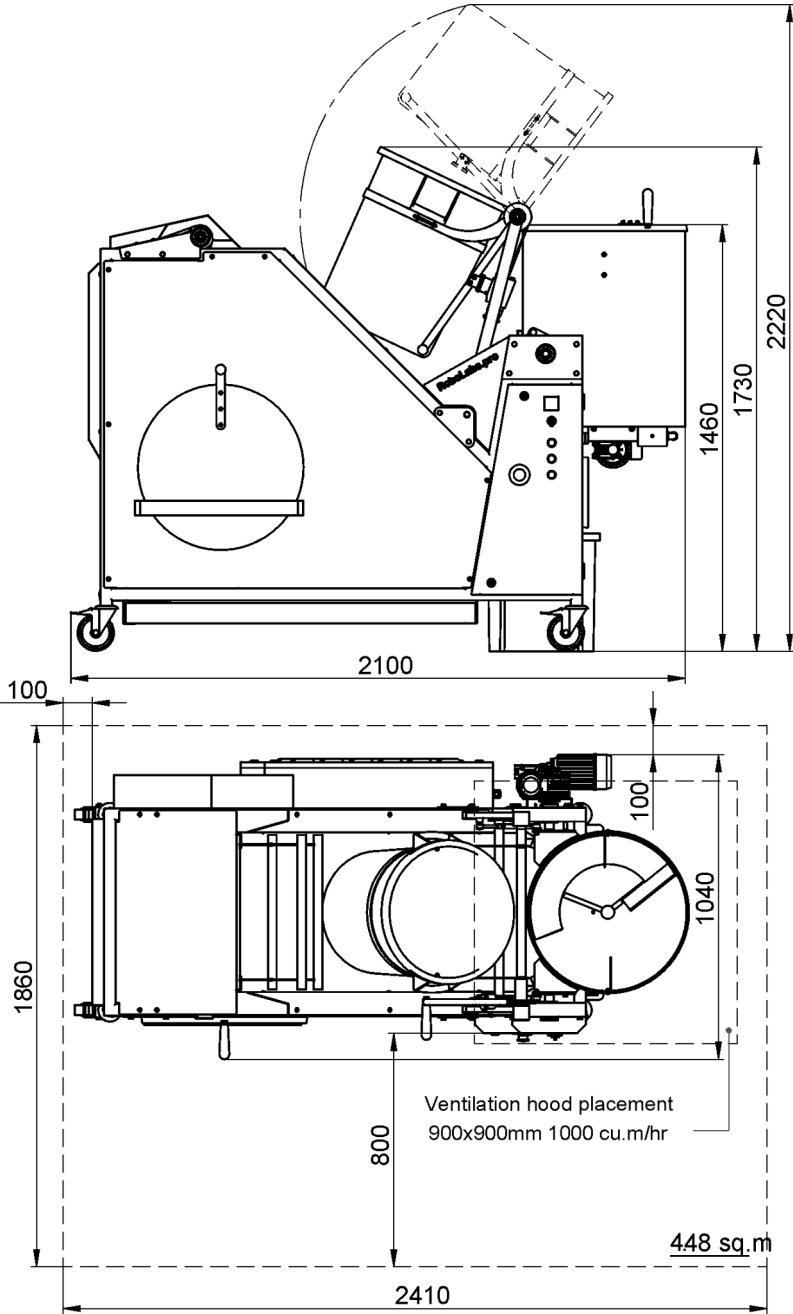

A ventilation hood measuring at least 900x900mm must be provided above the kettle, not less than 2,3 m from the floor, with a minimum capacity of 1000 m³/hr.

ELECTRIC CONNECTION



EQUIPMENT MUST BE GROUNDED!

5 wire 3 phase 400 V 16 Amp service – use **IEC 60309 3P+N+PE 16 A** plug

4 wire 3 phase 240 V 30 Amp service – use **NEMA 15-30P** plug



3P+N+PE 16 A



NEMA 15-30

Equipotential bonding

Equipotential bonding wire (up to 10 sq.mm) shall be connected to screw terminal marked with IEC 5021 sign:



Mixer rotation direction

Turn the machine on by turning the switch in CAMEL position, and then press blinking HEATING button. Check to see if the mixer inside the kettle rotates **clockwise**. If not, turn the machine off and swap any two phase wires in the plug.

TEMPERATURE REGULATOR SETUP



The regulator has three setting groups: 1st setting group, 2nd setting group, and SV setting group (the main indication mode).

The settings must be changed in the same order as they appear in the list. Note that after changing In-t (temperature sensor type) or Unl-t (temperature unit) values, parameters H-Su, L-Su, AL1, AL2, AHYS must be set again. The regulator has more parameters than listed below; if you see a parameter not from the list, skip it and move forward.

To access the 2nd group of parameters press and hold orange MODE button for 4 seconds; once you see PAr2 on the display, release the MODE button. To access the 1st group of parameters, press and hold the MODE button 2 seconds, until you see PAr1 on the display. Use MODE button to list parameters. Actual value of the parameter is shown in the lower line of the display. Use up or down arrow keys to change the value. Once the new value is set, press MODE button to proceed to the next parameter.

PARAMETER GROUP	PARAMETER	VALUE	DESCRIPTION
2 nd	LoC	oFF	Unlock all setting for changing
2 nd	In-t	YCA.H	Temperature sensor type
2 nd	UnIt	C (F)	Temperature unit, °C (°F)
2 nd	L-Su	90 (194)	SV low-limit value, °C (°F)
2 nd	H-Su	200 (392)	SV high-limit value, °C (°F)
2 nd	AL-1	An1._	AL1 alarm operation mode
2 nd	AL-2	An5._	AL2 alarm operation mode
2 nd	AHYS	10 (18)	Output hysteresis, °C (°F)
1 st	AL1	-10 (-18)	AL1 alarm temperature
1 st	AL2	50 (122)	AL2 alarm temperature
1 st	P	100 (180)	Proportional band, °C (°F)
1 st	I	0	Integral time
1 st	d	0	Derivative time
2 nd	LoC	LoC2	All settings locked, except SV
SV	SV	180 (356)	Default cooking temperature, °C (°F)

CONVEYOR MOTOR VFD SETUP



VFD setup must be performed while the drive is stopped (from the testing mode). To change or view parameter value, press ENTER, the display shows 00.__. Then use ▲ or ▼ keys to choose the first two digits of the parameter (for example, 02.). Now press ENTER again, display shows 02.00. Use ▲ or ▼ keys to choose the second two digits of the parameter, for example, 02.11. Press ENTER again to see the current value of the parameter. Change value, if needed, with ▲ or ▼ keys. Press ENTER to confirm and save the new value, the display shows **End**. Now use MODE button to return back to the previous level of selection or to the main mode.

PARAMETER	VALUE	DESCRIPTION
00.02	9	Settings initialization
00.03	1	Start-up display selection
01.00	120.00	Maximum output frequency
01.09	10.0	Acceleration time
01.10	10.0	Deceleration time
01.16	4	Auto acceleration/deceleration
02.00	3	Source of first master frequency command: RS-485
02.01	4	Source of first operation command: RS-485
02.04	0	Motor direction control
02.07	1	Up/Down mode
09.00	1	VFD communication address
09.01	2	Transmission speed: 19200 bps
09.02	3	Transmission fault treatment: no warning and keep operating
09.04	3	Communication protocol: RTU 8, N, 2

KETTLE TILT MOTOR VFD SETUP



VFD setup must be performed while the drive is stopped (from the testing mode). To change or view parameter value, press ENTER, the display shows 00.__. Then use ▲ or ▼ keys to choose the first two digits of the parameter (for example, 02.). Now press ENTER again, display shows 02.00. Use ▲ or ▼ keys to choose the second two digits of the parameter, for example, 02.11. Press ENTER again to see the current value of the parameter. Change value, if needed, with ▲ or ▼ keys. Press ENTER to confirm and save the new value, the display shows **End**. Now use MODE button to return back to the previous level of selection or to the main mode.

PARAMETER	VALUE	DESCRIPTION
00.02	9	Settings initialization
00.03	1	Start-up display selection
01.00	50.00	Maximum output frequency
01.09	1.0	Acceleration time
01.10	1.0	Deceleration time
01.16	0	Auto acceleration/deceleration
02.00	0	Source of first master frequency command: keypad
02.01	4	Source of first operation command: RS-485
02.04	0	Motor direction control
02.07	1	Up/Down mode
02.11	50.00	Keypad frequency command
09.00	2	VFD communication address
09.01	2	Transmission speed: 19200 bps
09.02	3	Transmission fault treatment: no warning and keep operating
09.04	3	Communication protocol: RTU 8, N, 2

To change the mode of display, press MODE button few times, until the display shows FXX.0. Use up and down arrow keys to change the reference frequency to F50.0

ELECTRIC COMPONENTS LAYOUT

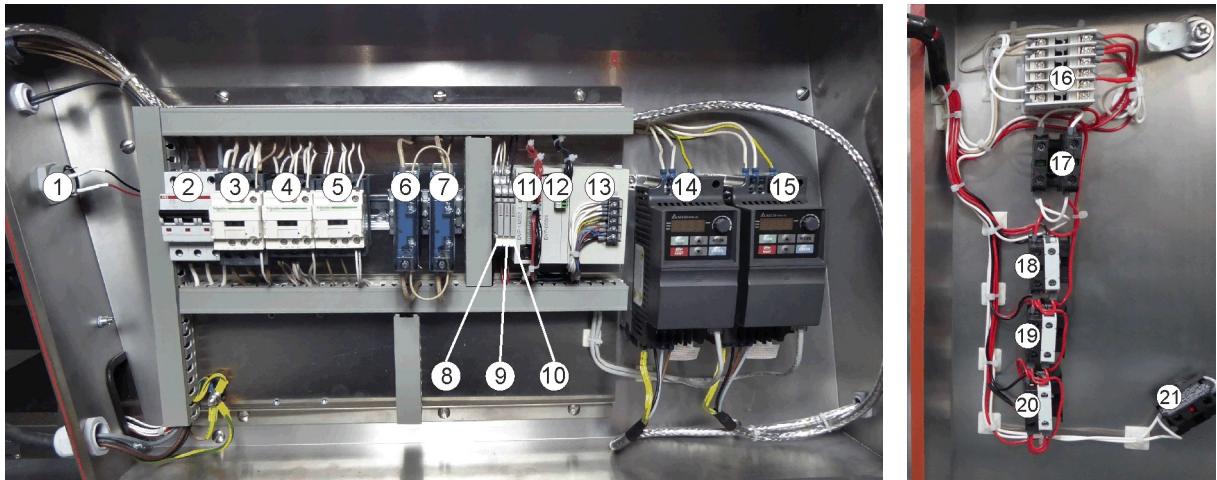

1. Buzzer BZ
2. Circuit breaker QF
3. Contactor KM2
4. Contactor KM1
5. Contactor KM3
6. Solid-state relay VS1
7. Solid-state relay VS2
8. Relay K3
9. Relay K1
10. Relay K2
11. PLC DC1
12. I/O extension module DC2
13. Power supply unit TV
14. VFD UZ1 (conveyor belt drive)
15. VFD UZ2 (kettle tilt drive)
16. Temperature regulator DC3
17. Switch SA2 (Cheese/OFF/Caramel)
18. Pushbutton SB1 (Heating)
19. Pushbutton SB2 (Mixing)
20. Pushbutton SB3 (Cooling)
21. E-Stop pushbutton SA1