

FOODS APPLICATIONS

technical catalogue

RD
RG
RB
RE
RC
HD
HG
RS
VERTICAL
CANTILEVER
RN
TS
RAM

SR SALVATORE
ROBUSCHI
PUMPS

Pompe centrifughe per ogni esigenza Centrifugal pumps for any need

Le pompe Salvatore Robuschi sono largamente utilizzate nel settore alimentare pur non essendo pompe sanitarie. Nell'industria della lavorazione degli alimenti infatti una minima parte delle pompe centrifughe richiede una certificazione sanitaria. L'Azienda ha una grandissima esperienza nel settore della produzione di succhi di frutta e concentrazione del pomodoro.

Le pompe con girante a canali sono il cuore degli impianti di evaporazione, grazie alla loro affidabilità e bassissimi valori NPSHr. Forniamo inoltre pompe per il lavaggio e la movimentazione di frutta e verdura e pompe per i sistemi di pastorizzazione, sterilizzazione, CIP e trattamento dei reflui.

Salvatore Robuschi è anche presenti nel settore della lavorazione della carne e della produzione di cibo per animali (pet food). Le nostre pompe, grazie all'elevata efficienza ed a bassi valori NPSHr, vengono utilizzate nella distillazione di alcohol sia per uso alimentare che industriale.

Although Salvatore Robuschi pumps are not provided with a sanitary certification, they are widely employed in food plants because it is not a compulsory requirement in the majority of cases. Salvatore Robuschi has a great experience in fruit juice processing and tomato concentrate.

The pumps with channel impellers are the heart of the evaporators' plants due to reliability and NPSHr low values. We produce pumps for fruit and vegetable washing and handling, pumps for pasteurisation, sterilization, CIP and waste treatment.

We also supply pumps for meat processing and pet food industry. Salvatore Robuschi pumps can be used for alcohol distillation both in food and industrial fields, thanks to low NPSHr values.

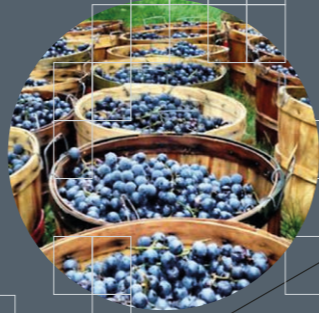

PROCESS

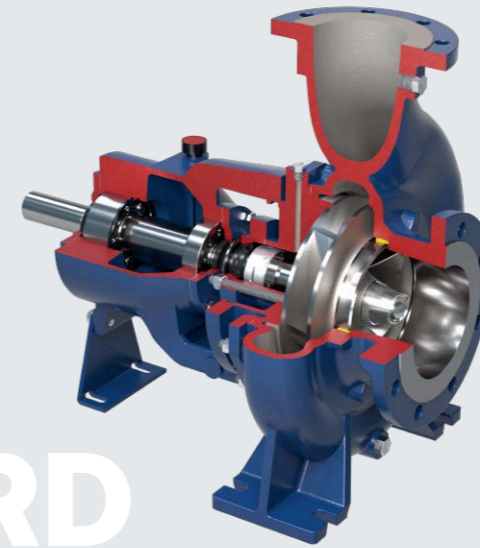

RD
Closed impeller ISO 2858

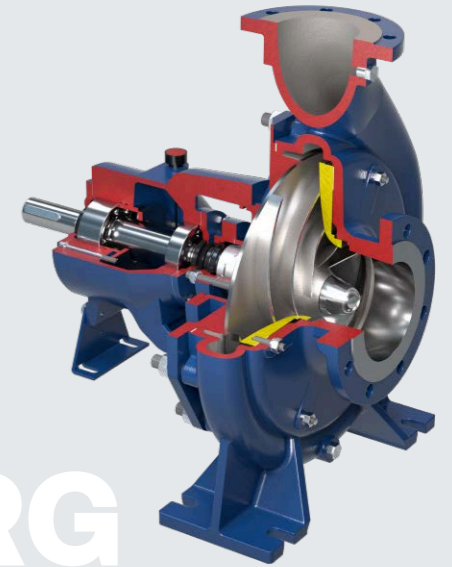

RG
Open impeller ISO 2858

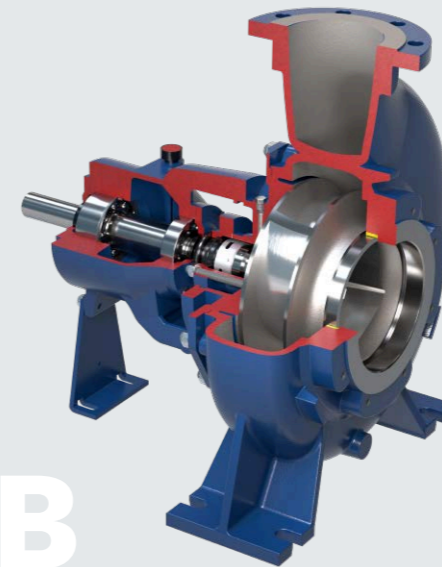

RB
Channel impeller

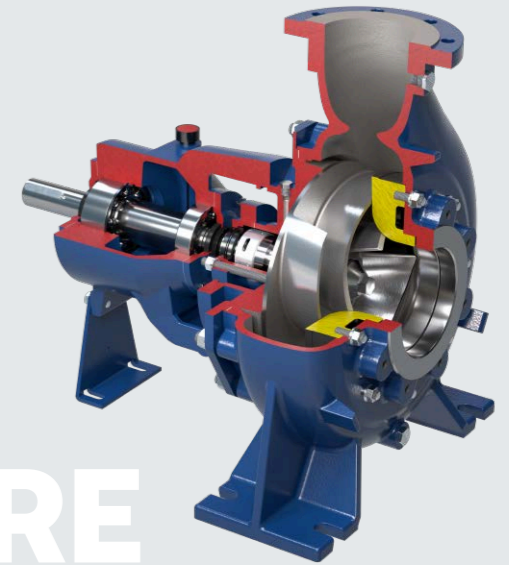

RE
Open channel impeller

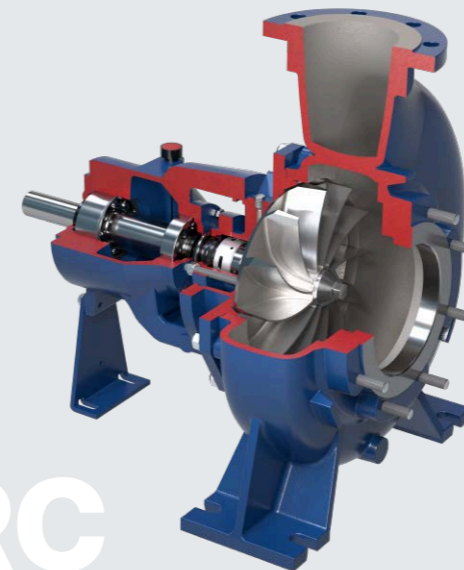

RC
Vortex impeller



VERTICAL

Closed, Open, Channel and Vortex impeller

VERTICAL



Vortex, Channel and Closed impeller

CANTILEVER



CLOSE COUPLED

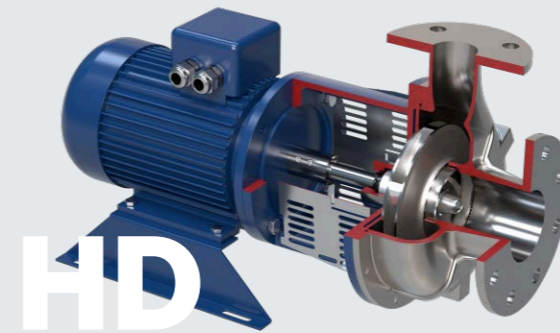

HD
Closed impeller

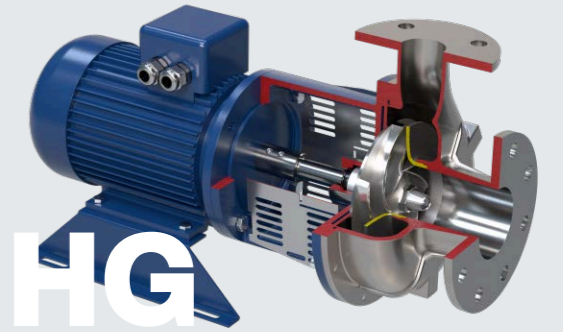

HG
Open impeller

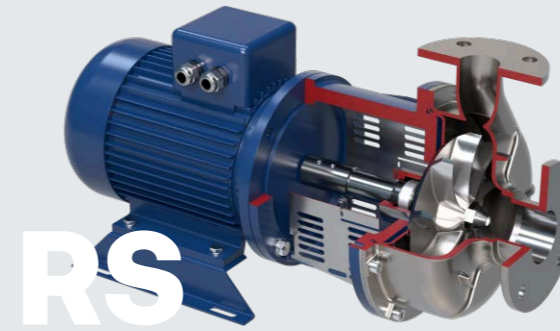

RS
Vortex impeller

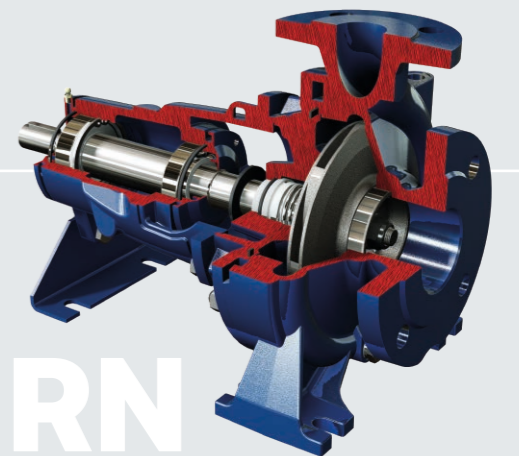

RN
Closed impeller EN 733

WATER

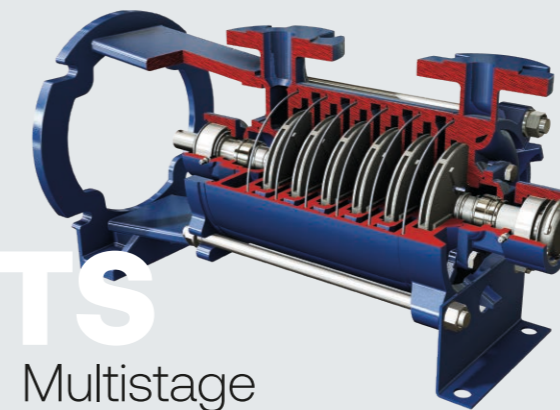

TS
Multistage

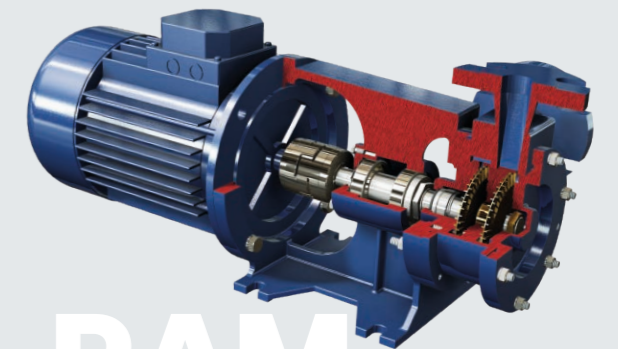

RAM
Peripheral impeller



RC

RECEIVING WASHING AND SORTING

Vegetables are unloaded into a collection channel, made in stainless steel or cement, into which is continuously pumped a quantity of water 3 to 5 times higher than the amount of unloaded vegetable. This liquid could contain pieces of vegetable, soil, branches, grass, etc.

Our RC pumps are used to send this high amount of water to the filters and remove all solids. Thanks to completely recessed impeller, RC can be used with liquid with **high concentration of suspended solids up to 150 mm.**



RB

ROTARY DRUM FILTERS

Rotary drum filters are ideal for removing fine suspended solids in recirculating systems where water reuse strategies are imperative.

Our RB pumps, thanks to the channel impeller, can move **without clogging problems and with high efficiency** large quantities of water containing small suspended solids.



RB

HOT BREAK

In the production of Hot Break tomato paste, the sorted product is finely crushed and heated at the temperature of complete enzymatic inactivation or higher (up to 105°C).

Our RB pumps, thanks to the channel impeller, can move **without clogging problems and with high efficiency** large quantities crushed tomatoes at high temperature.



RB

FORCED CIRCULATION EVAPORATOR

In this type of evaporator, liquid is pumped through heat exchanger tubes at high velocity avoiding precipitation and creating high turbulence; liquid passes through vapour separator for separation of vapour and finally condensing the vapour in the condenser.

Our RB pumps are one of the key points of the plant as they must ensure the movement of the product in heavy conditions, in terms of **vacuum , viscosity and specific gravity** of the product (in particular for the final product).



RD

TUBE IN TUBE PASTEURIZER

Pasteurization is a process that applies heat to destroy pathogens in foods. The product is sterilized before packaging by a tube in tube heater or plate heat exchanger. The heating is done with superheated water instead of direct live steam to avoid thermal stress.

Our RD pumps are used for **superheated water up to 150°C** recirculation.



RB

COOLING TOWER

A cooling tower is a specialized heat exchanger in which air and water are brought into direct contact with each other in order to reduce water's temperature. Towers dedicated to food industry ,in particular to evaporator, could recirculate water containing traces of suspended solids.

Our RB pumps, thanks to the channel impeller, can move **without clogging problems and with high efficiency** large quantities of hot water slightly contaminated



RD

**FISH PROCESSING:
FISHMEAL STICKWATER**

Stickwater is obtained as a by-product in the wet process of manufacturing fish meal and fish oil. Stickwater is often concentrated by evaporation to be used in animal feeds as a source of vitamins and amino acids.

Our RD are used for recirculating stickwater juice in a multiple effect falling film evaporator.

Thanks to investment casting technology, RD can work in heavy conditions in terms of **NPSHa, lower than 1.5 m, and viscosity, up to 300 cP.**



RC

**RENDERING:
MEAT AND OFFAL PROCESSING**

Rendering is a process for separating fat from animal tissue. Rendering serves the invaluable function of converting what would be otherwise a waste materials into useful products.

Our RC pumps, thanks to the vortex impeller, can move **without clogging problems** hot fluid grease with large quantity of small bones and fine abrasive particles.



RCV

SLAUGHTERHOUSES

Meat processing plants (MPPs) produce large amounts of slaughterhouse wastewater (SWW) because of the slaughtering process and cleaning of facilities.

Cleaning waters together with processing wastes (blood, meat, feathers, etc.) are transferred to the storage tanks before recovery.

Our vertical pumps RCV with vortex impeller and rubber bottom bearing bush are able to transfer process waste water with high percentage of hard solid without clogging problem.



HG

**ALCOHOL PRODUCTION:
DISTILLATION**

Distillation in simple terms, is basically the process of separating a liquid or vapor mixture into its component parts, through vaporization and condensation. Since alcohol boils at a lower temperature than water, it will turn to steam before the water does, and rise up in the still. Collect and cill the vapors of alcohol and collect the alcohol from the still

Our HG pumps, thanks to the semi-open impeller, can easily recirculate mixture of wort (juice) and alcohol without clogging problem. Furthermore they must ensure the movement of product in heavy conditions in terms of vacuum.



RB

**ALCOHOL PRODUCTION:
STILLAGE**

Stillage, also called distillery wastewater or vinasse, is the aqueous byproduct from the distillation of alcohol. Vinasse is used as feedstock in biofuel production and as an agricultural fertilizer and soil conditioner.

Our RB pumps, thanks to the channel impeller, can move **without clogging problems and with high efficiency** large quantity of vinasse.

Furthermore they must ensure the movement of product in heavy conditions in terms of vacuum.



HD

CROSS FLOW FILTRATION

Cross-flow filtration system based on the use of ceramic membranes can filter any type of product with even high degrees of suspended solids and ensure better clarity, the maximum recovery of product. They also permit the processing of products containing filtration aids, such as bentonite.

Our HD pumps, thanks to investment casting technology, can recirculate not filtered wine with high efficiency and high resistance against corrosion. They can also withstand high temperatures, sterilizing, and even cleaning with aggressive chemicals



RSA

VACUUM FILLER

Vacuum filler is an automatic machine suitable for vacuum filling glass and tin containers of different sizes and shapes carrying whole or diced fruit or vegetables in liquid such as oil, vinegar, brine, syrup, sauce, etc.

Our RSA are equipped with special seal able to work under vacuum and suitable for all filling medium. Connections are DIN 11851 in compliance with food standards.



RB

SPIRAL PASTEURIZER

The spiral pasteurizer is an automatic machine suitable for pasteurizing and/or cooling the products previously packaged in containers made of glass, plastic and tin and of different size and shape.

Our RB pumps, thanks to the channel impeller, can work with hot liquid (up to 98°C) with low NPSHa, lower than 1 m.



RC

**DEEP FRYING:
DIRTY HOT OIL**

Deep frying is a cooking method in which food is submerged in hot oil. In a continuous deep frying machine, the product runs continuously on a conveyor belt through the heated oil and gets gently fried or cooked according to product temperature, oil temperature and belt speed.

Our RC, thanks to vortex impeller, can work with dirty hot oil. Oil with suspended fine particles is recirculating through a heat exchanger or a filter with working temperature that can easily reach 190°C.



RG

**DAF:
DISSOLVED AIR FLOTTATION**

DAF technology refers to the method of liquid-solid separation by air introduction. The fat and grease along with light solids are moved to the surface creating a sludge blanket. Thus, it can be continuously removed via scum scraping.

Our RG, thanks to the semi-open impeller and special seal arrangement, can work with a solution of water and air up to 10%. Air drum for saturating the pressurized effluent water with air is not required.



RB

WWTP

Conventional wastewater treatment consists of a combination of physical, chemical, and biological processes and operations to remove solids, organic matter and, sometimes, nutrients from wastewater.

Our RB pumps, thanks to the channel impeller, can move without clogging problems and with high efficiency large quantities of sludges in the primary treatment (circular clarifier with surface skimmer).



HG

**CIP:
CLEANING IN PLACE**

Cleaning in Place (CIP) refers to the use of a mix of chemicals, heat and water used to clean machinery, vessels or pipe work without dismantling the plant. CIP is principally concerned with scales, foreign bodies or bacteria removal.

Our HG pumps with body and impeller in casted AISI 316 (investment casting up to 8mm thickness) grant high resistance against corrosion caused by caustic and acid solutions at high temperature. Thanks to semi-open impeller, HG can easily pump scales coming from the systems.

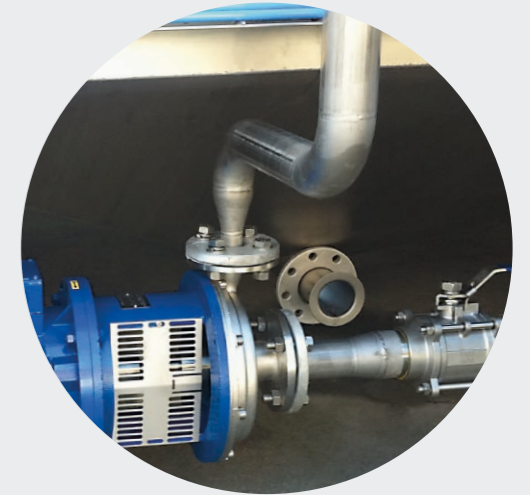

La nostra storia ha inizio nel 1935 in una piccola officina nel centro di Parma dove Salvatore Robuschi, il fondatore dell'azienda, costruiva e riparava piccole pompe.

Nel corso degli anni l'assistenza si è trasformata in produzione e oggi, quasi 90 anni dopo, la Salvatore Robuschi è uno dei principali produttori di pompe di processo in Italia e ricopre un ruolo strategico anche a livello mondiale.

La gamma odierna comprende pompe centrifughe orizzontali e verticali con girante chiusa, aperta, a canali ed arretrata utilizzate in settori quali trattamento acque, chimico, alimentare e molto altro.

Ciò che contraddistingue la Salvatore Robuschi dalla concorrenza è il supporto tecnico: grazie alla continua crescita degli ultimi decenni è stato possibile creare uno staff tecnico-commerciale altamente qualificato che, con competenza e rapidità, è in grado di sviluppare soluzioni personalizzate per ogni esigenza del cliente.

L'ampia gamma, l'affidabilità, la totale modularità dei prodotti, i brevi tempi di consegna ed il supporto puntuale sono i motivi principali per cui la Salvatore Robuschi continua ad accrescere la propria quota di mercato anno dopo anno, senza però tralasciare l'attenzione per l'ambiente ed il benessere dei dipendenti.

La struttura organizzativa

L'ufficio tecnico commerciale è in grado di affiancare il cliente nella scelta del prodotto, intesa come vera e propria guida nell'identificazione della corretta macchina da destinare all'uso specifico.

Direttiva ATEX

L'azienda è anche in grado di fornire pompe certificate secondo le norme ATEX, categorie 2 e 3, per l'utilizzo in atmosfera esplosiva.

Attenzione per l'ambiente

L'attenzione che la Salvatore Robuschi riserva all'ambiente ha portato l'azienda a sviluppare una politica ecosostenibile investendo nella posa di un impianto fotovoltaico composto da 1.000 m² di pannelli di ultima generazione con capacità produttiva media annuale di 1 MW.

Our history starts back in 1935 in a small workshop in Parma where Salvatore Robuschi, the company founder, built and repaired small pumps.

Over the years service has turned into production and today, almost 90 years later, Salvatore Robuschi is one of the largest manufacturers of process pumps in Italy and plays a strategic role worldwide too.

Today's range includes horizontal and vertical centrifugal pumps with closed, open, channel and vortex impeller used in applications such as water treatment, chemicals, food and much more.

The main difference between Salvatore Robuschi and other competitors is the technical support: thanks to the continuous growth in the last decades it has been possible to create a highly qualified technical-sales staff that, with competence and rapidity, is able to develop tailor-made solutions for every customer need.

The wide range, the reliability, the total modularity of its products, the short delivery times and the punctual support are the main features that allow Salvatore Robuschi to keep on increasing its market year after year, always keeping in mind the attention to the environment and the employees' welfare.

Organisational structure

The sales-technical department is well-qualified to assist the customer in choosing the most suitable machine and meet customers specific needs.

Atex directive

Salvatore Robuschi is able to supply pumps according to the ATEX rule, category 2 & 3, suitable to be installed in hazardous area.

Environment

Salvatore Robuschi concern with the environment led to an eco-friendly policy investing in a photovoltaic system that has an average capacity per year of 1 MW thanks to its 1,000 m² panels.

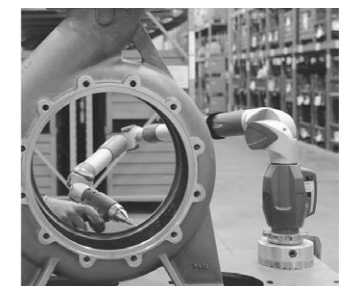
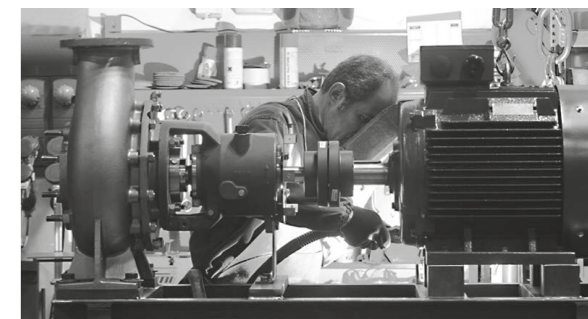



Salvatore Robuschi & C. srl
via Emilio Gino Segrè 11/a
43122 Parma | Italy

t +39 (0)521 606285
f +39 (0)521 606278

salvatorerobuschi.com
srpumps.com

sr@salvatorerobuschi.com

