

S10-2HY Inline Hygienic Style 3A Certified

Example application

Measures 0-40% milk fat. 2" Triclover fitting. Install directly into food product lines.



Dimensions

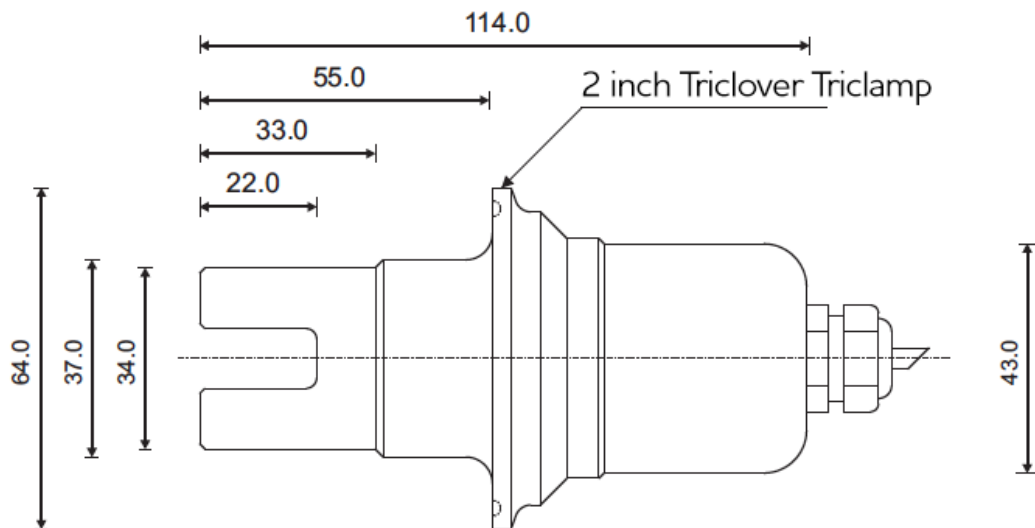

Key features



SELF-COMPENSATING

Multi-beam sensor, virtually eliminates drift due to contamination or electronic ageing.



ONE-PIECE BODY

No lenses to leak, glass-free design.



SIMPLE TO USE

Simple user interface



RELIABLE

Accurate, repeatable & reliable.

Example applications

Hygienic style sensors are designed for installation directly into food product lines where CIP cleaning is used.

Monitoring high solids concentrations, for example fruit pulp monitoring, milk fat concentration, product to water interface, solids concentration control.

Milk fat

0 to 40%

(the measuring range will vary according to media and particle characteristics)

Further specifications

ACCURACY

+/- 2% of reading

REPEATABILITY

+/- 1% of reading

TEMPERATURE

0 to 85°C operating range

PRESSURE

10 Bar

CABLE

Polyurethane-covered cable rated to 95°C. Extension cables can be supplied to extend the cable up to 50m.

TRANSMITTER

Quadbeam MXD75 or MXD73

Model no. selection guide

BASIC MODEL NO.:

S10 - Measuring range 0 - 40% milk fat*.

*the measuring range will vary according to media and particle characteristics

BODY STYLE

2HY - Hygienic Style body with 2" Triclover fitting

WAVE LENGTH

880 - 880nm Standard. Other wave lengths available

BODY MATERIAL

PP - Polypropylene

CABLE

10 - Both immersion and hygienic sensors are supplied with a 10m cable as standard. Other lengths available

CONNECTOR

NC - No Connector. Cores stripped and crimped for direct connection with the MXD Transmitters

CA - Amphenol Connector. For use with Hygienic sensors using extension cables.

Sample model no: S10-2HY-880-PP-10-NC

Quadbeam Technologies Ltd – Contact us

Email – info@quadbeam.com

Call US – (303) 923 5273

Call international – +64 9 238 4609

Call NZ – 09 238 4609