



Be in Control

2024 VAV & CONTROL DAMPER PRODUCTS CATALOG



AZV-TUB TERMINAL BOX

DESCRIPTION

The **AZPV-TUB** series boxes are terminal boxes designed for variable air volume applications (with or without FSD flow sensor).

Order **AZV-TUB-XX** for pressure Dependent with no Flow Sensor
 Order **AZV-TUB-XX-PI** for pressure Independent with Flow Sensor



CHARACTERISTICS

Galvanized steel housing, satin finish, 0.8 mm (22 gauge) 12.5 mm (1/2") internal fiberglass acoustic insulation covered with an acrylic layer and fiberglass reinforcement. The insulation complies with the following standards: NFPA- 90A & 90B, SMACNA, Can/ULC S102-M88 and CGSB 51- GP-11M.

- Single blade, dual density control damper with Polyolefin insulation seal.
- "S" shaped output joint.
- 12.5 mm (1/2") shaft compatible with most actuators.

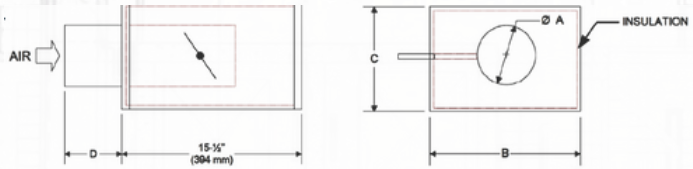

TECHNICAL SPECIFICATIONS

Model	Air Flow CFM (l/s)	Velocity FPM (m/s)	A Inlet Diameter	B Width	C Height	D 610 Length	Weight LBS (kg)
AZV-TUB05	130 (60)	953 (4.84)	5" (127mm)	12" (305mm)	8" (203mm)	6.25" (158.75mm)	13 (5.90)
AZV-TUB06	200 (95)	1019 (5.18)	6" (152mm)	12" (305mm)	8" (203mm)	6.25" (158.75mm)	14 (6.35)
AZV-TUB07	275 (130)	1029 (5.23)	7" (178mm)	12" (305mm)	8" (203mm)	6.25" (158.75mm)	15 (6.80)
AZV-TUB08	350 (165)	1003 (5.10)	8" (203mm)	12" (305mm)	10" (254mm)	6.25" (158.75mm)	16 (7.26)
AZV-TUB09	450 (210)	1019 (5.18)	9" (229mm)	12" (305mm)	10" (254mm)	6.25" (158.75mm)	16 (7.26)
AZV-TUB10	550 (260)	1008 (5.12)	10" (254mm)	14" (356mm)	12" (305mm)	6.25" (158.75mm)	19 (8.62)
AZV-TUB12	800 (375)	1019 (5.19)	12" (305mm)	14" (356mm)	12" (305mm)	6.25" (158.75mm)	23 (10.43)
AZV-TUB14	1100 (520)	1029 (5.23)	14" (356mm)	16" (406mm)	15" (381mm)	6.25" (158.75mm)	29 (13.15)
AZV-TUB16	1400 (660)	1003 (5.10)	16" (406mm)	20" (508mm)	18" (457mm)	8" (203mm)	34 (15.42)
AZV-TUB18	1800 (849)	1018 (5.17)	18" (457mm)	22" (559mm)	20" (508mm)	10" (254mm)	40 (18.14)
AZV-TUB20	2200 (1038)	1008 (5.12)	20" (508mm)	24" (610mm)	22" (559mm)	10.5" (266.7mm)	45 (20.41)
AZV-TUB22	2600 (1227)	985 (5.00)	22" (559mm)	26" (660mm)	24" (610mm)	14" (356mm)	51 (23.13)



**AZC-VC2000-PI
VAV ZONE CONTROLLER**



DESCRIPTION

AirZoe **AZC-VC2000-PI** series zone controllers are designed for pressure independent variable air volume zoning systems. The built-in microprocessor offers precise digital control to maximize performance. The outputs and control sequences are all fully configurable, either locally or remotely, using free software or from the digital room sensor. The on-board brushless actuator provides electronic feedback on damper position. When in a network, the CAP2000s can share information such as the occupancy state, the demand, the supply temperature and more. For pressure dependent systems a **AZC-V2000** can be used.

FEATURES

- Proportional integral (PI) control loops maximize performance
- Precise control of the Belimo actuator using Halomo® technology
- 1 digital output and 1 analog output, both protected with resettable fuses
- Supports Modbus and BACnet protocols
- Remote monitoring and configuration with FREE AirZoe Focus software
- Standalone or networked (up to 127 nodes)
- Configurable sequences for radiant floor and duct heater
- Analog input can monitor discharge air, occupancy, CO2 levels and more
- Works with or without a flow sensor
- Monitoring and configuration from a digital sensor
- Quick and easy installation using detachable numbered terminal blocks
- Possibility of multiple actuator control
- FlexiZone system facilitates multiple zone management by evaluating the average weighted demand of the zones using customized groups

TECHINCAL SPECIFICATIONS

SUPPLY	24 VAC ±10%, 50/60 Hz, Class 2
POWER	3 VA (Typ Consumption), 5 VA (Max Consumption), 24 VA (Input)
INPUTS	1 general purpose analog input supporting 3 types of input signals (0-5V, 4-20mA and thermistor), as well as an RS485 communication port for a digital zone temperature sensor
FLOW SENSOR	0-2 inches of H2O (optional)
DIGITAL OUPUT	1 triac 10-30 VAC dry contact, 300 mA max (resettable fuse), ON/OFF or pulsed, heating or cooling
ANALOG OUTPUT	0-10 VDC, 40 mA max (resettable fuse), modulating, ON/OFF or pulsed, heating or cooling
INDICATION LIGHTS (LED)	State of each output / Communication/Power / State of microprocessor
CASING	Molded ABS, UL94-HB
MICROPROCESSOR	PIC18F6722, 8 bits, 40 MHz, 128KB FLASH memory
COMMUNICATION	1 RS485 network port (Modbus RTU or BACnet MS/TP - up to 127 nodes), and 1 RS485 port for digital sensor or computer interface.
BAUD RATES	9600, 19200, 38400, 57600, 76800, 115200
CONNECTION	Removable screw-type terminal blocks (16 AWG max)
DIMENSIONS	5" x 5" x 3" (127 mm x 127 mm x 77 mm)
WEIGHT	1.15 lbs (0.5 kg)
ENVIORNMENT	32-122 °F (0-50 °C) Non-Condensing
CERTIFICATION	UL916 Energy Management Equipment, CAN /CSA-C22.2, FCC part 15: 2012 class B, RoHS
ACTUATOR	Belimo® with Halomo® technology, 45 in-lb Minimum Spindle Length: 37 mm / 1.5 in (Belimo LM) Spindle Diameter Range: 6-20 mm / 0.25-0.75 in (Belimo LM)

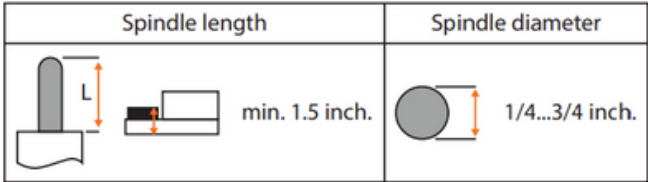



AZC-T1000F & AZC-T200F VAV DIGITAL SENSOR



DESCRIPTION

The **AZC-T1000F** digital sensor is designed to work with a variety of AirZoe controllers, to which it transmits information such as the ambient zone temperature, heating and cooling setpoints, occupancy override status and other valuable parameters. The AZC-T1000 also provides the user with an access point to view and configure any parameter of the connected controller through a very intuitive onscreen menu system. The AZC-T1000 has a circular touchpad, a backlit graphical LCD and an auxiliary analog input, useful for an additional temperature reading.

FEATURES

- 10K Ω Type 3 NTC thermistor 1% precision
- Circular capacitive touchpad and graphical display, which allow simple and intuitive control
- Designed to work with various AZC-C1000 and AZC-VC2000 series controllers, sending them zone temperature, setpoints and other configuration parameters
- Easy wiring with numbered screw type terminal block or RJ45 modular jack
- Input for auxiliary temperature sensor: Room temperature (average or remote) or slab temperature (for radiant floor applications)
- Circular touchpad and curved features offer a modern look. Other colors available!

TECHNICAL SPECIFICATIONS

- Supply: 24 VAC \pm 10%, 50/60 Hz, Class 2
- Power: 5 VA (max) • Inputs: 1 analog input (Thermistor 10K type 3), 10 bit resolution • Outputs: None
- Screen: LCD 80x130 pixels with backlighting
- Interface: Circular capacitive touchpad
- Sound: Audible feedback during user interactions
- Microprocessor: Atmel 32 bits, 60 MHz, 256KB FLASH memory
- Connection: Screw type terminal blocks (16 AWG max) and RJ45 modular jack
- Dimensions: 3.23" x 4.96" x 1" (82 mm x 126 mm x 25 mm)
- Weight: 0.5 lbs (0.23 kg)
- Environment: 32-122 °F (0-50 °C)
- Mounting: Standard electrical box 2" x 4"
- Certification: FCC part 15: 2012 class B

DESCRIPTION

The **AZC-T200F** digital sensor is designed to work with a variety of AirZoe controllers, to which it transmits information such as the ambient zone temperature, heating and cooling setpoints as well as the schedule override request from the zone. The modern, attractive, low-profile enclosure is suitable for classrooms, hotels, executive areas, office spaces and other commercial areas. Mounting hardware is provided for installation on dry wall or a 2" x 4" electrical junction box.

FEATURES

- 10K Ω Type 3 NTC thermistor 1% precision
- Standard 10K Ω setpoint potentiometer +/- 20% tolerance across the range
- Embossed momentary pushbutton used to override unoccupied status
- Easy wiring with numbered screw type terminal block or RJ45 modular jack
- Oval shape and curved features offer a modern look. Other colors available!

TECHNICAL SPECIFICATIONS

- Supply: 24 VAC \pm 10%, 50/60 Hz
- Power: 2 VA (max)
- Interface: Rotary knob and schedule override push-button
- Microprocessor: SyncMOS 8-bit, 11 MHz, 64KB FLASH memory
- Communication: Modbus RTU (RS485), 57600 bps
- Connection: Screw type terminal blocks (16 AWG max) and RJ45 modular jack
- Dimensions: 3.23" x 4.96" x 1" (82 mm x 126 mm x 25 mm)
- Weight: 0.35 lbs (0.16 kg) • Environment: 32-122 °F (0-50 °C)
- Mounting: Standard electrical box 2" x 4"
- Certification: FCC part 15: 2012 class B



AZC-EZ SERIES ZONE CONTROLLER



AZC-EZ2N

- Economy 2-Zone Controller
- Electronic Limit Control™
- Intelligent SmartStaging™
- Bright, Backlit LCD Display
- Dependable Field-Proven Platform
- Supply Air Sensor Included
- Plastic Enclosure and Spare Fuse Included
- AZ Exclusive Start-Up Equipment Test Mode LED Indicates Blown Fuse
- 3-Heat/2-Cool
- Gas/Electric and Heat Pump
- Uses ANY 5-Wire Thermostat
- Mounts with 2 Screws
- Quick-Connect Screw-less Wiring Terminals
- Simple Step-by-Step System Setup
- NO DIPSWITCHES - No Guessing - No Confusion
- Color LED Indicators for Thermostat and Equipment Calls
- Two-Color LED Indicators Show Damper Position
- Mix and Match Gas/Electric and Heat pump Thermostats



AZC-EZ2F

- Full-Featured 2 and 4 Zone Controller
- Electronic Limit Control™
- Intelligent SmartStaging™
- On-Board Fresh Air and Economizer Control – Use 2-Wire or 3-Wire Damper
- Return Air or Fresh Air Temperature Monitoring Available
- Stand-Alone or Communicating Expansion Module
- Quick-Connect Screw-less Terminals
- NO DIPSWITCHES - No Confusion - No Guessing
- Automatic Changeover for Maximum Comfort and Flexibility
- Adjustable Staging Time and Temp for Maximum Comfort
- Constant Supply Air Monitoring from ELC™ Ensures Customer Safety
- Mix and Match Single-Stage Heat Pump and Gas/Electric Thermostats
- 5-Year No Hassle Warranty



AZC-EZ4F

- Supply Air Sensor and Return Air Sensor Included
- LED Indicates Blown Fuse
- Bright, Backlit LCD Display
- Plastic Enclosure and Spare Fuse Included
- AZ Exclusive Start-Up Equipment Test Mode
- Dependable, Field-Proven Platform
- Simple Step-By-Step System Setup
- Display Indicates Full System Status
- Color-Coded LED Indicators for Thermostat and Equipment Calls
- Selectable Zone-1 Priority for More Customer Control
- Zone Specific Ventilation - Energize Fan from Any Thermostat
- Use ANY 5-Wire Thermostat
- Economy Mode Allows for More Efficiency Control
- 3-Heat/2-Cool

COMPATIBLE WITH GAS/ELECTRIC - ELECTRIC HEAT PUMP - DUAL FUEL



**AZD-POC
SUPPLY AIR DAMPER 3-WIRE POWER
OPEN/POWER CLOSE**

The **AZ-POC**-series low pressure two-position damper was developed for precise control of supply air in the HVAC duct system. The solid aluminum shaft provides a lifetime of service. The damper actuator with built-in LED lights is designed for years of care-free operation. The power open/power close design guarantees precise control of supply air into each zone. Poron® rubber blade edges provides a positive seal for the blade. Our gasketed damper blade is designed to compensate when installation conditions are not exact, and the damper is not perfectly round. Long-life nylon bushings ensure a quiet, low friction operation of the damper. Heavy-duty galvanized steel ribbed cylinder provides strength to keep the damper round. One crimped end and one straight end allows for flexible installation. 30-Second operation to full open or closed position. A minimum open position can be set to bleed air for ventilation or duct balancing.

- DEPENDABLE POWER OPEN/POWER CLOSE/MODULATING
- LED INDICATORS FOR FULL OPEN AND CLOSED POSITIONS
- LED INDICATORS FLASH WHEN BLADE IS MOVING
- INSULATION PAD UNDER MOTOR AVAILABLE SIZES: 6", 7", 8", 9", 10", 12", 14", 16", 18" & 20"
- LONG-LIFE ACTUATOR
- 5 YEAR FACTORY WARRANTY

PART NUMBER	D CYLINDER DIAMTER (INCHES)	L CYLINDER LENGTH (INCHES)
POC06	6	12
POC07	7	12
POC08	8	12
POC09	9	12
POC10	10	12
POC12	12	12
POC14	14	14
POC16	16	16
POC18	18	18
POC20	20	20
6" THRU 10" - 24 ga. G90 Galvanized		
12" thru 20" - 22 ga. G90 Galvanized		

SPECIFICATIONS

POWER	24VAC, 2 VA typical (3 VA Max)
ACTUATOR	XCI POCJ Brushless Motor Design 18 in-lb Torque Power-Open/Power-Close 30 Second Operation Cycle Max 90 Degree Travel
INDICATOR	LED Indicates Full Open or Close
WIRING	3 Screw Terminals PO, PC, Common Use 18/3 Solid Core Wire

DESCRIPTION :

DDC : DIRECT DIGITAL CONTROLLER
DB : DISTRIBUTION BOARD (LIGHTING PANEL)
S/S : START/STOP
ST : STATUS



SUPPLY AIR DAMPER 3-WIRE POWER OPEN/POWER CLOSE

The SmartZone™ **AZD-RPOCA**-series low pressure two-position damper was developed for precise control of supply air in the HVAC duct system. Rigid aluminum components provide a strong, yet lightweight construction. The damper actuator with built-in LED lights is designed for years of care-free operation. The power open/power close design guarantees precise control of supply air into each zone. Long-life nylon gears drive the opposed blades open and closed. Opposed blade design reduces turbulence in the air stream. 30 Second operation to full open or closed position. A minimum open position can be set to bleed air for ventilation or duct balancing. End of shaft marked with high-visibility blade position indicator. Custom sizes are available.

- DEPENDABLE POWER OPEN/POWER CLOSE
- LED INDICATORS FOR FULL OPEN AND CLOSED POSITIONS
- INSULATION PAD UNDER MOTOR REDUCES CONDENSATION
- AVAILABLE SIZES: 8 X 8 UP TO 30 X 30
- LONG-LIFE ACTUATOR
- 5 YEAR FACTORY WARRANTY



POWER	24VAC, 2 VA typical (3 VA Max)
ACTUATOR	XCI POCM Brushless Motor Design 10 in-lb Torque Power-Open/Power-Close 30 Second Operation Cycle Max 90 Degree Travel
INDICATOR	LED Indicated Full Open or Close Blink When Opening & Closing
WIRING	3 Screw Terminals PO, PC, Common Use 18/3 Solid Core Wire

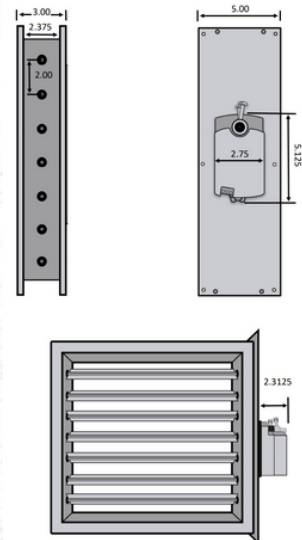

The **AZD-RPUCA** series low pressure two-position & modulating damper was developed for precise control of supply air in the HVAC duct system. Rigid aluminum components provide a strong, yet lightweight construction. The damper actuator with built-in LED lights is designed for years of care-free operation. The power/open close design guarantees precise control of supply air into each zone. Long-life nylon gears drive the opposed blades open and closed. Opposed blade design reduces turbulence in the air stream. 15 second operation to full open or closed position. A minimum open position can be set to bleed air ventilation or duct balancing. End or shaft marked with high-visibility blade position indicator. Custom sizes are available. Quick turnaround on orders. Most orders ship the same day.

- DEPENDABLE POWER OPEN/POWER CLOSE/MODULATING
- LED INDICATORS FOR FULL OPEN AND CLOSED POSITIONS
- LED INDICATORS FLASH WHEN BLADE IS MOVING
- INSULATION PAD UNDER MOTOR REDUCES CONDENSATION
- AVAILABLE SIZES: 8 X 8 UP TO 30 X 30 & CUSTOM SIZES
- LONG-LIFE ACTUATOR
- 5 YEAR FACTORY WARRANTY
- WORKS WITH MOST AFTERMARKET ZONING SYSTEMS
- WORKS WITH CARRIER/BRYANT/ION ZONING SYSTEMS



AZD-BBD BAROMETRIC BYPASS DAMPER



- STATIC PRESSURE CONTROLLING DESIGN
- ADJUSTABLE WEIGHTED ARM
- STURDY STEEL CYLINDER
- 24 GAUGE G-90 MATERIAL
- SOLID ALUMINUM SHAFT
- SHAFT CAN BE ATTACHED ON EITHER SIDE OF DAMPER
- RUBBER SEAL PROVIDES POSITIVE STOP OF AIR FLOW
- LONG LIFE NYLON SHAFT BUSHINGS QUALITY DESIGN

FEATURES

- FLEXIBLE INSTALLATION - ONE CRIMPED END, ONE STRAIGHT END
- MOUNT IN ANY POSITION - VERTICAL OR HORIZONTAL
- HIGH VISIBILITY ARROW INDICATES AIRFLOW DIRECTION
- AVAILABLE SIZES: 8", 9", 10", 12", 14", 16"

STANDARD SPECIFICATIONS

- FRAME: 20 gauge galvanized formed steel.
- BLADE: 20 gauge galvanized formed steel.
- BEARINGS: 1/2" diameter nylon.
- AXLES: 3/8" square plated steel rods.
- QUADRANT: Heavy gauge plated steel w/ wingnut locks.
- FINISH: Standard Mill.
- MAXIMUM VELOCITY: 1500 F.P.M.
- MINIMUM SIZE: 4" diameter.
- MAXIMUM SIZE: 20" diameter



AZD-BBD Spring Loaded Backdraft Dampers Spring Loaded Backdraft Damper

Neoprene damper seal minimizes leakage
 20 gauge steel housing, aluminum spring loaded butterfly damper blades
 Gasket designed to withstand temperatures from -22 F to 180 F
 Requires from 0.04 to 0.08 in. wg pressure to open
 Simple installation in any position – entire assembly inserts into duct
 Exterior foam gasket assures a tight seal against duct
 4", 5", 6" & 8" sizes include stamped metal sleeve with center pin design
 10" & 12" sizes include rolled metal sleeve with center post design

AZD-BAFD BUTTERFLY AIR FLOW DAMPER

- Foam seal provides minimal leakage.
- No springs or metal hinges to go bad.
- Works for both horizontal or vertical applications.
- Ideal for intake or exhaust applications.
- Due to its unique design, it opens easily with normal air flow
- and closes by gravity.



AZD-MAN Manual Control DAMPER

AZD-MAN Manual - Hand Operated Balancing Dampers
 Hand Operated Dampers are designed to be used when a motorized system is not practical. Our rotary-to-linear (rack and pinion) mechanical actuator assembly securely holds the damper in position for precise dependable settings.



AZ-AD-PF Access Doors



AirZoe's Press On Hinge & Cam (H) is used to provide easy access into rectangular ductwork. Double paneled with front and back metal plates, and 1" insulation



CABLE CONTROLLED AIR FLOW DAMPER FOR OUTSIDE AIRSTREAM WITH GASKET & INSIDE AIRSTREAM WITH BLADE NOT GASKETED

AirZoe's Cable Damper Systems are designed to be used when a motorized system is not practical. The flexible cable and wire can be routed around electrical conduit, piping and other obstructions, without fear of binding or catching. Rotary-to-linear (rack & pinion) mechanical actuator assembly securely holds the damper in position for precise dependable settings. Cables can be connected together if a greater length is required.

FEATURES & BENEFITS

- Quick and easy to install
- Substantially reduces installation costs
- Works with round, oval or rectangular dampers
- Can be attached to any manufacturers dampers
- AirZoe can build the damper tube or attach it to your fitting
- Route the cable from the damper upstream to a more accessible location to adjust the air volume to a satisfactory level
- Available with or without a gasketed damper which allows a better seal.
- Adjust air flow volume from the rotary actuator without needing to access the ceiling/damper
- Rotation of adjustment knob yields approx. 1.65" of linear travel.
- Custom angles & detents are available, or use standard 15-detent or smooth.
- Different D-shaft lengths are available.
- 1.75" dia. printed knobs for Fan, Temperature, or Mode.
- Proven durability in OEM trucking, bus, and agriculture applications.
- Meets FMVSS 302 Requirements.

CABLE DAMPER SYSTEM INCLUDES

- A push/pull sleeved cable and assembled Actuator that provides rotary actuation with a simple turning motion
- 42 inches of sleeved cable with end units for easy attachment to the adjustment lever of the damper blade
- A cable mounting support to mount the cable to the casing of the damper

SPECIFICATIONS

AZ-RD-CCD-WG-XX

PART #	SIZE	SLEEVE CABLE SIZE	PRINTED KNOB DIAMETER	APPROXIMATE KNOB ADJUSTMENT SIZE
AZ-RD-CCD-WG-04"	4	42	1.75in	1.65in
AZ-RD-CCD-WG-05"	5	42	1.75in	1.65in
AZ-RD-CCD-WG-06"	6	42	1.75in	1.65in
AZ-RD-CCD-WG-07"	7	42	1.75in	1.65in
AZ-RD-CCD-WG-08"	8	42	1.75in	1.65in
AZ-RD-CCD-WG-10"	10	42	1.75in	1.65in
AZ-RD-CCD-WG-12"	12	42	1.75in	1.65in
AZ-RD-CCD-WG-14"	14	42	1.75in	1.65in
AZ-RD-CCD-WG-16"	16	42	1.75in	1.65in
AZ-RD-CCD-WG-18"	18	42	1.75in	1.65in
AZ-RD-CCD-WG-20"	20	42	1.75in	1.65in
AZ-RD-CCD-WG-22"	22	42	1.75in	1.65in
AZ-RD-CCD-WG-24"	24	42	1.75in	1.65in

AZ-RD-CCD-XX

PART #	SIZE	SLEEVE CABLE SIZE	PRINTED KNOB DIAMETER	APPROXIMATE KNOB ADJUSTMENT SIZE
AZ-RD-CCD-04"	4	42	1.75in	1.65in
AZ-RD-CCD-05"	5	42	1.75in	1.65in
AZ-RD-CCD-06"	6	42	1.75in	1.65in
AZ-RD-CCD-07"	7	42	1.75in	1.65in
AZ-RD-CCD-08"	8	42	1.75in	1.65in
AZ-RD-CCD-10"	10	42	1.75in	1.65in
AZ-RD-CCD-12"	12	42	1.75in	1.65in
AZ-RD-CCD-14"	14	42	1.75in	1.65in
AZ-RD-CCD-20"	20	42	1.75in	1.65in
AZ-RD-CCD-22"	22	42	1.75in	1.65in
AZ-RD-CCD-24"	24	42	1.75in	1.65in

Rectangle and Square Cable Dampers also Available



AZ-CVR Constant Volume Regulators



Constant Volume Regulators (CVRs) are devices used in HVAC systems to maintain a consistent airflow rate, regardless of pressure variations. They work by automatically adjusting the airflow to a predetermined volume, ensuring efficient and balanced ventilation.

Functionality: CVRs limit airflow into or out of a room, preventing over-conditioning and ensuring uniform air distribution. **Applications:** They are commonly used in high-rise buildings to counter the thermal stack effect and ensure proper air intake and exhaust across multiple floors. **Benefits:** CVRs enhance energy efficiency, improve air balancing, and maintain consistent indoor air quality.

Part #	Diameter	CFM Range	Part #	Diameter	CFM Range
AZCV-4-015050	3 15/16"	15-50	AZCV-6-050100	5 29/38"	50-100
AZCV-4-050100	3 15/16"	50-100	AZCV-6-100180	5 29/38"	100-180
AZCV-4-100180	3 15/16"	100-180	AZCV-6-180300	5 29/38"	180-300
AZCV-5-015050	4 59/64"	15-50	AZCV-8-180300	7 7/8"	180-300
AZCV-5-050100	4 59/64"	15-50	AZCV-8-300500	7 7/8"	300-500
AZCV-5-100180	4 59/64"	100-180	AZCV-10-300500	9 27/32"	300-500
AZCV-5-015050	5 29/32"	15-50	AZCV-10-450800	9 27/32"	450-800

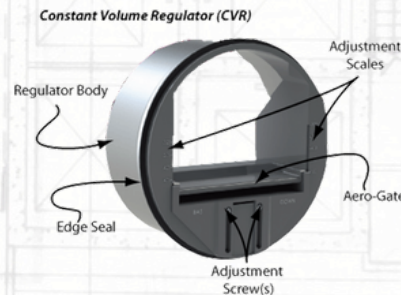

AZCV-XB - Outlet Box



AZCV-4B	4"RD x 6 x 6
AZCV-5B	5"RD x 6 x 6
AZCV-6B	6"RD x 8 x 8
AZCV-8B	8"RD x 10 x 10
AZCV-10B	10"RD x 12 x 12

AZFD-XxX - Fire Damper

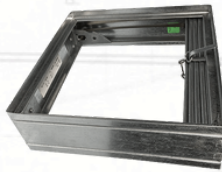

AZFD-6x6	6 x 6
AZFD-8x8	8 x 8
AZFD-10x10	10 x 10
AZFD-12x12	12 x 12

AZAD-XxX Air Outlet

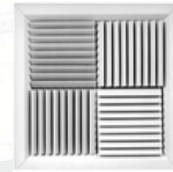

AZAD-6	6" x 6" - 4 way Air Outlet
AZAD-8	8" x 8" - 4 way Air Outlet
AZAD-10	10" x 10" - 4 way Air Outlet
AZAD-12	12" x 12" - 4 way Air Outlet



AZ-MOD Constant Volume Regulators

STANDARD SPECIFICATIONS

- FRAME: 20 gauge galvanized formed steel.
- BLADE: 20 gauge galvanized formed steel.
- BEARINGS: 1/2" diameter nylon.
- AXLES: 3/8" square plated steel rods.
- QUADRANT: Heavy gauge plated steel w/ wingnut locks.
- FINISH: Standard Mill.
- MAXIMUM VELOCITY: 1500 F.P.M.
- MINIMUM SIZE: 4" diameter.
- MAXIMUM SIZE: 20" diameter



AZ-MOD Manual - Hand Operated Balancing Dampers
 Hand Operated Dampers are designed to be used when a motorized system is not practical. Our rotary-to-linear (rack and pinion) mechanical actuator assembly securely holds the damper in position for precise dependable settings.



DESCRIPTION	
DDC	DIRECT DIGITAL CONTROLLER
DB	DISTRIBUTION BOARD (LIGHTING PANEL)
S/S	START/STOP
ST	STATUS



AZ-BDD Backdraft Damper



Spring Loaded Backdraft Dampers

Neoprene damper seal minimizes leakage

20 gauge steel housing, aluminum spring loaded butterfly damper blades

Gasket designed to withstand temperatures from -22 F to 180 F

Requires from 0.04 to 0.08 inches wg pressure to open

Simple installation in any position – entire assembly inserts into duct

Exterior foam gasket assures a tight seal against duct

4", 5", 6" & 8" models include stamped metal sleeve with center pin design

10" & 12" models include rolled metal sleeve with center post design

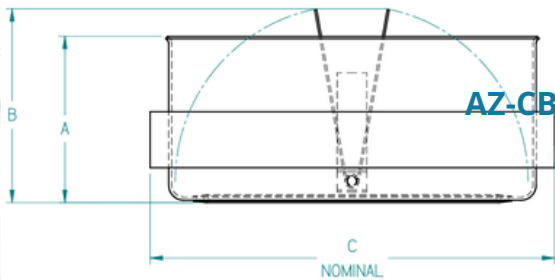

AZ-CBD Backdraft Damper

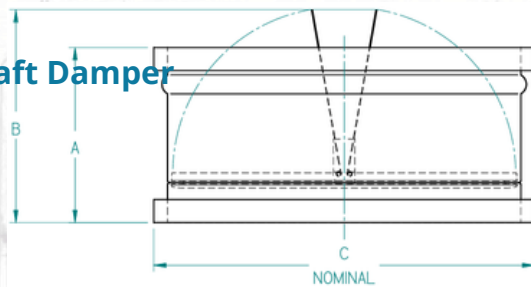

DAMPER		DIMENSIONS (IN INCHES)		
MODEL	SIZE	A	B	C
BDD100	4	1.75	2.00	3.80
BDD125	5	2.00	2.50	4.80
BDD150	6	2.50	3.00	5.80
BDD200	8	2.75	3.75	7.80

DAMPER		DIMENSIONS (IN INCHES)		
MODEL	SIZE	A	B	C
BDD250	10	4.75	5.75	9.8
BDD300	12	6.25	6.75	11.8

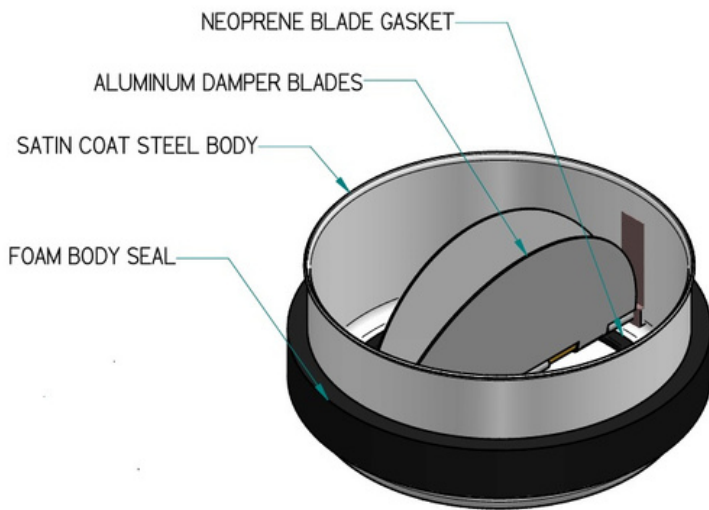

DDC : DIRECT DIGITAL CONTROLLER
 DB : DISTRIBUTION BOARD (LIGHTING PANEL)
 S/S : START/STOP
 ST : STATUS

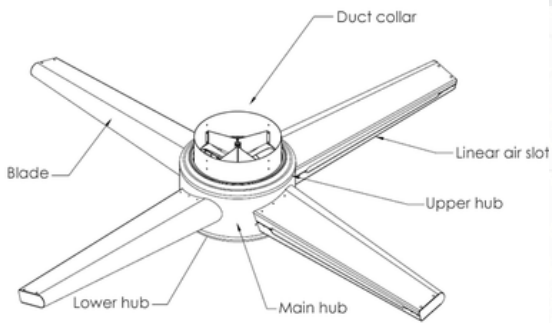

- Heavy gauge aluminum hub and blade construction.
- Upper and lower hub is spun for rigidity and appearance.
- Blades are engineered and formed to allow for great aerodynamics.
- Dual self-aligning oil-lite bushings.
- Dual high quality thrust bearings.
- Upper collar constructed of heavy gauge galvanized metal for a more secure connection.
- Standard powder coated colors of white, black, Silver and aluminum.
- Custom colors are available to match any architectural needs.
- Aluminum construction keeps the weight down to allow for ease of installation.
- No Electricity Required
- Assembly Required

DAD-08W

Airflow CFM	164	215	327	360	388
Blade RPM	31	38	58	63	79
Static Pressure	0.04	0.06	0.14	0.16	0.19
Velocity Pressure	0.02	0.03	0.08	0.09	0.09
Total Pressure	0.06	0.09	0.22	0.25	0.28
Throw in feet	1 - 2 - 5	1 - 3 - 7	2 - 4 - 9	2 - 5 - 9	3 - 6 - 9
NC Rating	20	27	38	40	42

*All pressures are given in w.g. All measurements are given in inches.

*Throw values for the 8" D.A.D. are based on an exposed installation at 10' A.F.F.

DAD-10W

Airflow CFM	255	388	440	512	702
Blade RPM	27	35	45	54	74
Static Pressure	0.05	0.09	0.10	0.18	0.34
Velocity Pressure	0.01	0.02	0.03	0.04	0.09
Total Pressure	0.06	0.11	0.13	0.22	0.43
Throw in feet	1 - 3 - 8	2 - 4 - 9	2 - 5 - 10	3 - 7 - 11	4 - 8 - 12
NC Rating	21	33	35	42	51

*All pressures are given in w.g. All measurements are given in inches.

*Throw values for the 10" D.A.D. are based on an exposed installation at 13' A.F.F.

DAD-12W

Airflow CFM	350	450	653	758	835	967	1069
Blade RPM	22	29	41	48	54	62	70
Static Pressure	0.05	0.07	0.14	0.18	0.23	0.27	0.32
Velocity Pressure	0.01	0.01	0.02	0.04	0.07	0.07	0.10
Total Pressure	0.06	0.08	0.16	0.22	0.31	0.34	0.42
Throw in feet	n/a	n/a	2 - 4 - 11	2 - 5 - 12	3 - 6 - 13	4 - 8 - 13	4 - 9 - 14
NC Rating	21	29	40	43	47	54	58

*All pressures are given in w.g. All measurements are given in inches.

*Throw values for the 12" D.A.D. are based on an exposed installation at 16' A.F.F.

DAD-08W

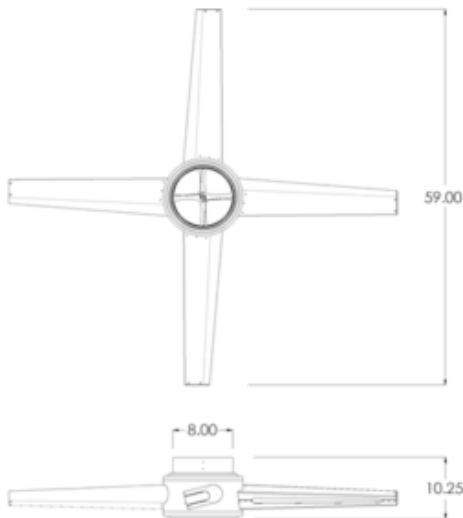

DAD-10W

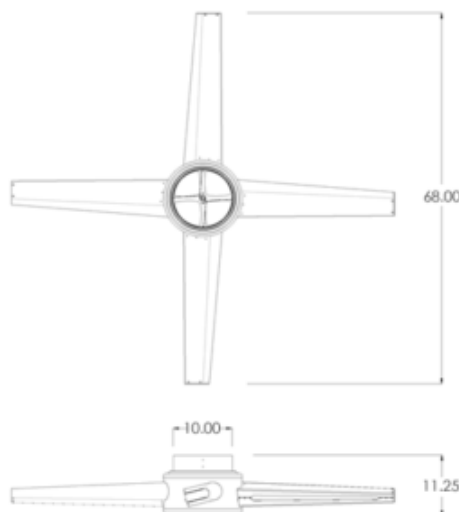

DAD-12W

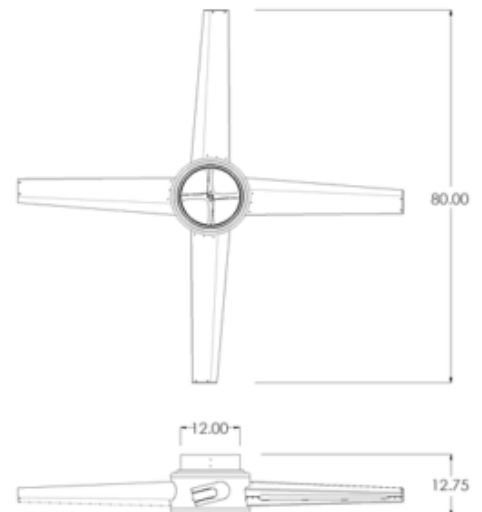

Throw Data

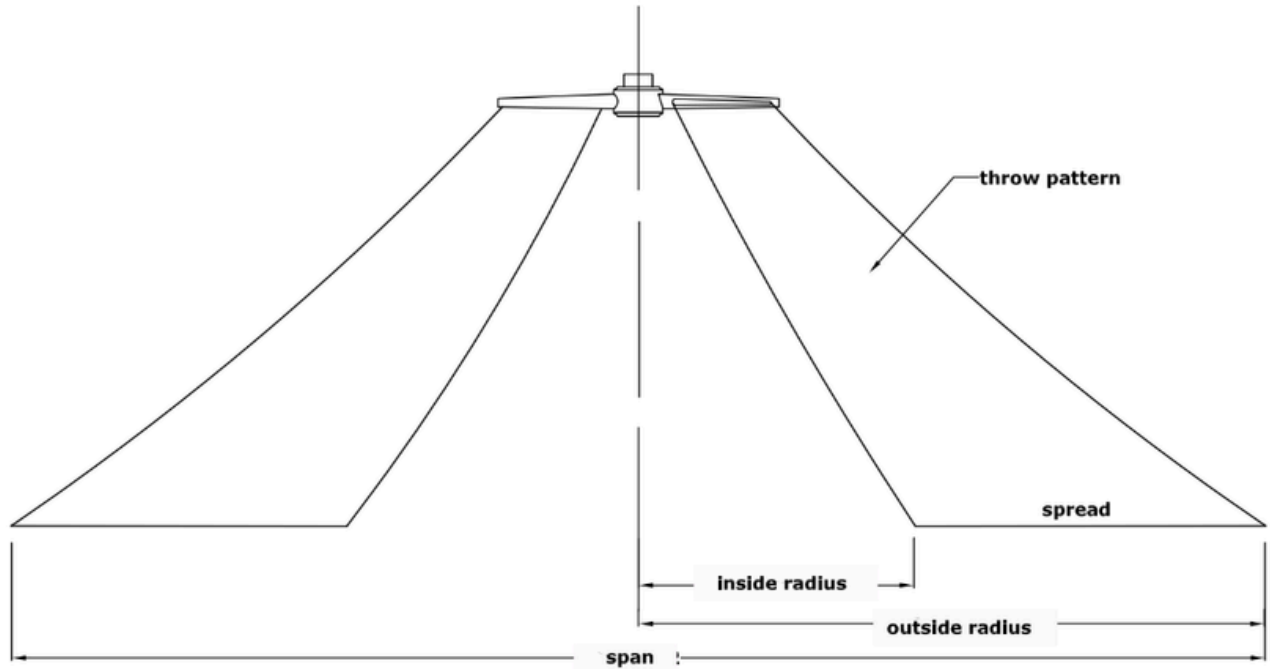

HEIGHT	8" @ 300 CFM	8" @ 300 CFM	8" @ 300 CFM	10" @ 440 CFM	10" @ 440 CFM	10" @ 440 CFM	12" @ 600 CFM	12" @ 600 CFM	12" @ 600 CFM
-	Inside	Outside	Spread	Inside	Outside	Spread	Inside	Outside	Spread
8	6'-4"	12'-1"	5'-9"						
9	7'-0"	14'-5"	7'-5"						
10	7'-9"	14'-5"	7'-5"	7'-11"	16'-2"	8'-3"			
11	8'-6"	16'-11"	8'-5"	8'-7"	17'-3"	8'-8"			
12	9'-4"	18'-5"	9'-1"	9'-5"	18'-7"	9'-2"			
13				10'-1"	20'-1"	10'-0"			
14				11'-1"	21'-3"	10'-2"	11'-2"	22'-3"	11'-1"
15				11'-8"	22'-7"	10'-11"	11'-9"	23'-1"	11'-4"
16				12'-6"	24'-0"	11'-6"	12'-7"	24'-6"	11'-11"
17							13'-2"	25'-9"	12'-7"
18							13'-11"	27'-0"	13'-1"
19							14'-9"	28'-6"	13'-9"
20							15'-7"	29'-9"	14'-2"

- Span equals two times outer radius
- Field acquired numbers may vary based on installation
- Highlighted measurements show optimal range of height for each size of diffuser.



Be in Control

DESCRIPTION	
DDC	DIRECT DIGITAL CONTROLLER
DB	DISTRIBUTION BOARD (LIGHTING PANEL)
S/S	START/STOP
ST	STATUS