

1
1 SALON GROUNDPLAN

NOTES:

- FURNITURE PLACEMENT NOT INCLUDED
- MOULDINGS SIMPLIFIED IN PLAN VIEW FOR EASE OF READING
- MASKING DIMENSIONS ON PLATE NO.2

FOR ESTIMATE ONLY



COMPOSED BY KIRKE MECHEM
DIRECTED BY STEPHANIE HAVEY
SCENERY DESIGNED BY LEO MURPHY
AGNES DE MILLE THEATER

SCALE: 3/8" = 1'-0"

PLATE NO.
1 OF 14

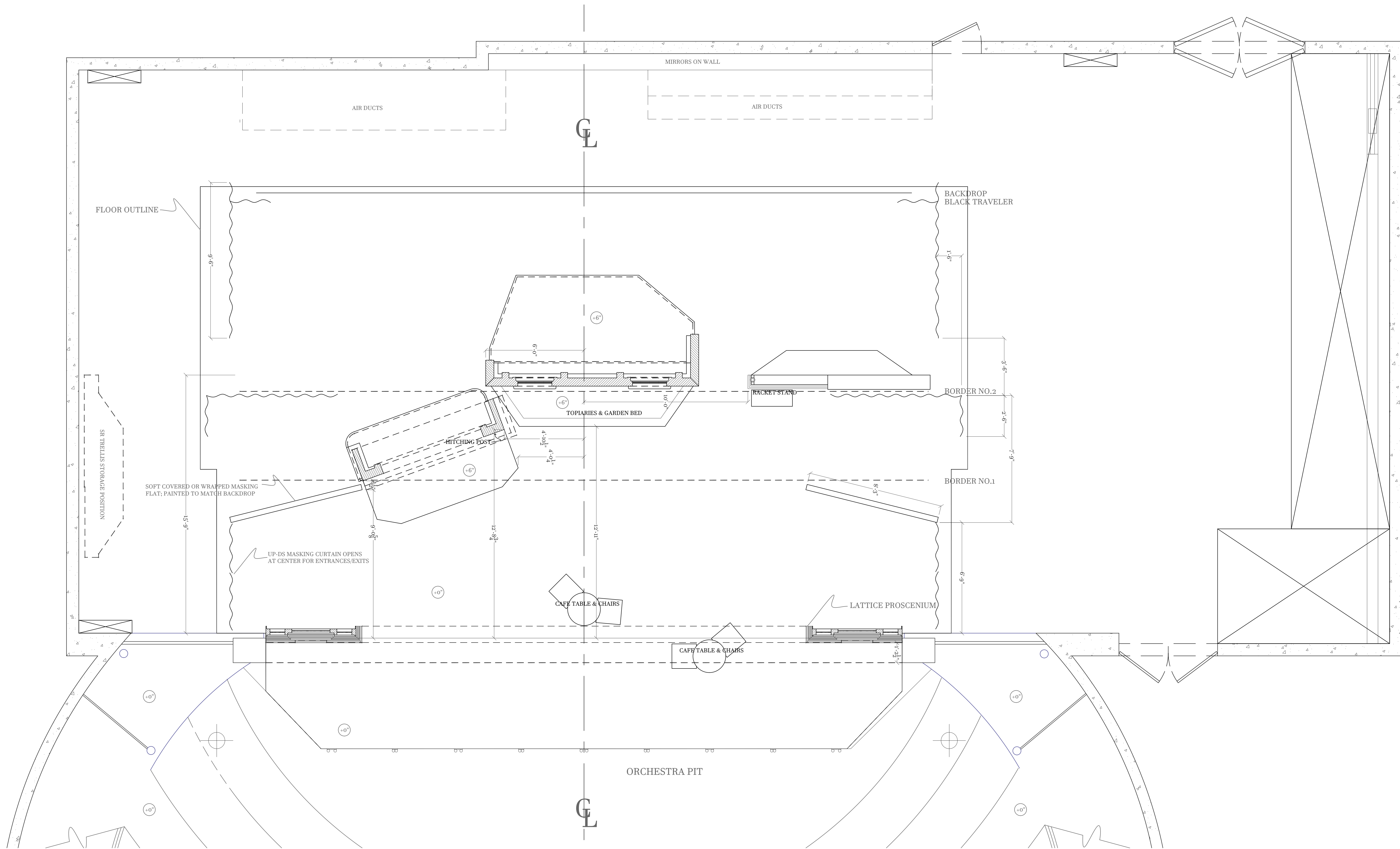

NOTES:

- FURNITURE PLACEMENT NOT INCLUDED
- MOULDINGS SIMPLIFIED IN PLAN VIEW FOR EASE OF READING

FOR ESTIMATE ONLY



COMPOSED BY KIRKE MECHEM
DIRECTED BY STEPHANIE HAVEY
SCENERY DESIGNED BY LEO MURPHY
AGNES DE MILLE THEATER

SCALE: 3/8" = 1'-0"

PLATE NO.
2 OF 14

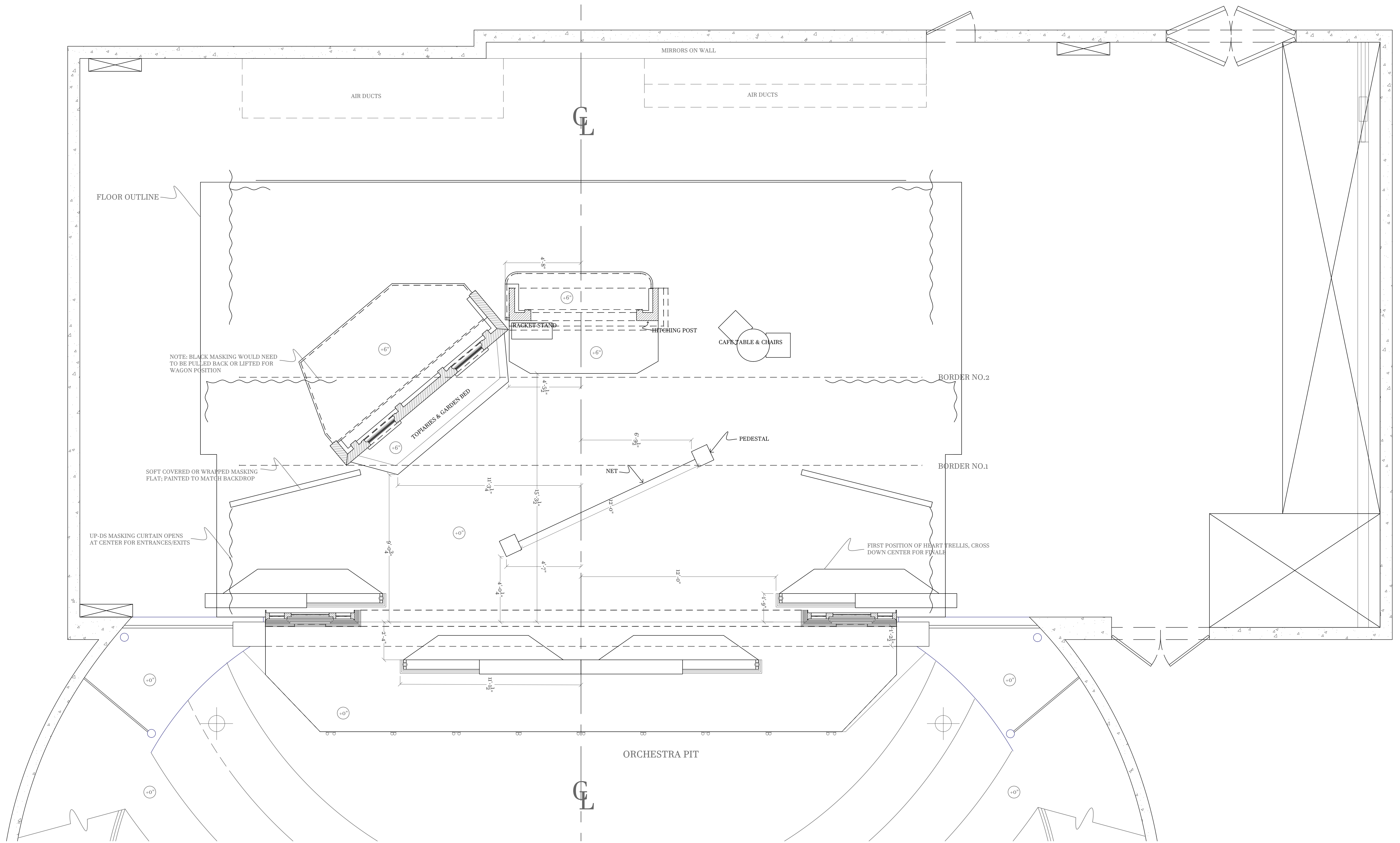

NOTES:

- BOTH POSITIONS FOR HEART TRELLIS UNITS SHOWN, START SCENE IN OFFSTAGE POSITION AND TRANSITION TO DOWNSTAGE CENTER
- FURNITURE PLACEMENT NOT INCLUDED
- MOULDINGS SIMPLIFIED IN PLAN VIEW FOR EASE OF READING
- MASKING DIMENSIONS ON PLATE NO.2

FOR ESTIMATE ONLY



COMPOSED BY KIRKE MECHEM
DIRECTED BY STEPHANIE HAVEY
SCENERY DESIGNED BY LEO MURPHY
AGNES DE MILLE THEATER

SCALE: 3/8" = 1'-0"

PLATE NO.
3 OF 14

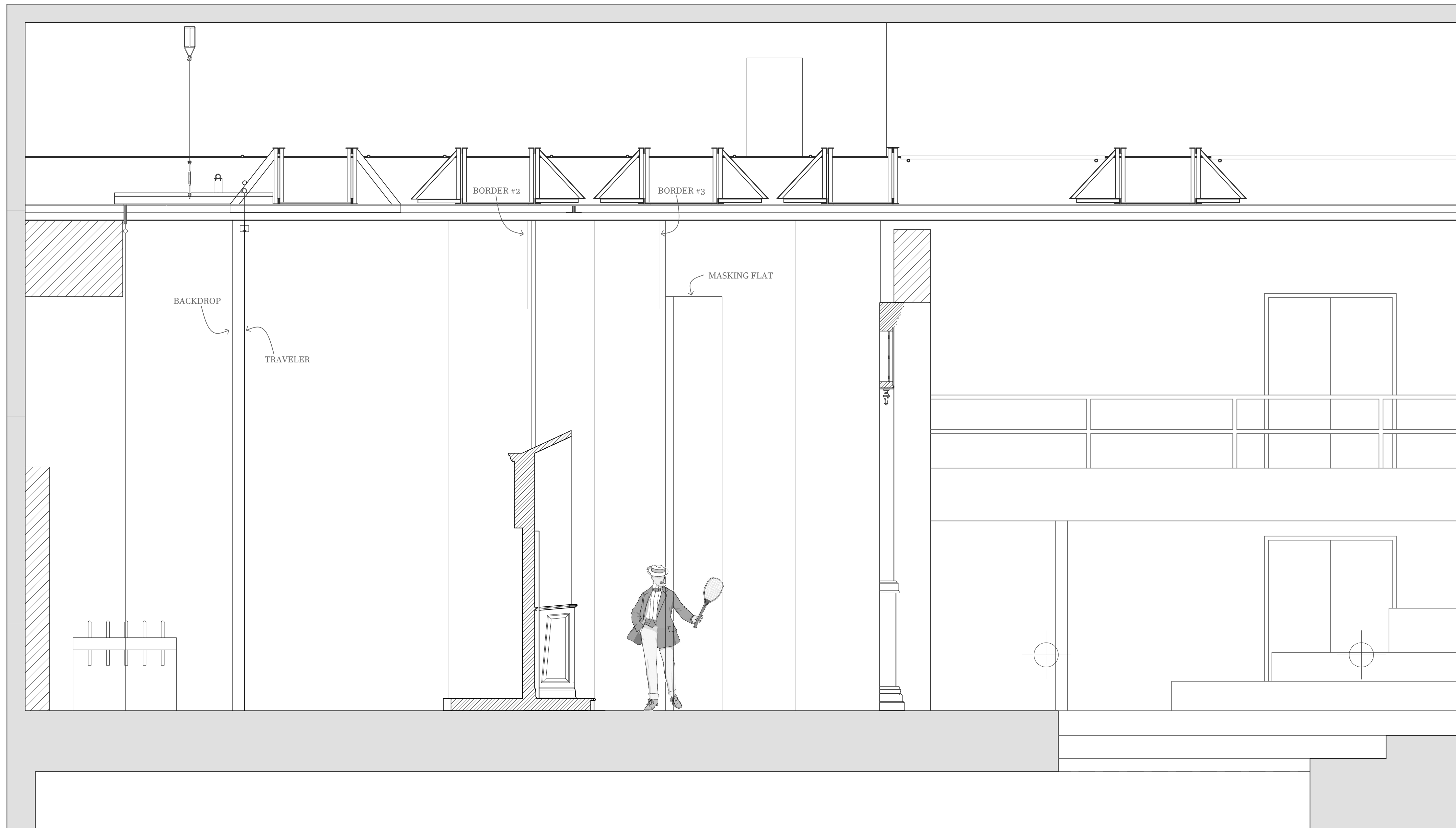

1
4

SALON SECTION

FOR ESTIMATE ONLY

NOTES:

- MOULDINGS MAY BE SIMPLIFIED FOR READABILITY
- TRIM HEIGHT OF BORDERS IS 16'-6"



COMPOSED BY KIRKE MECHEM
 DIRECTED BY STEPHANIE HAVEY
 SCENERY DESIGNED BY LEO MURPHY
 AGNES DeMILLE THEATER

SCALE: 3/8" = 1'-0"

PLATE NO.
 4 OF 14

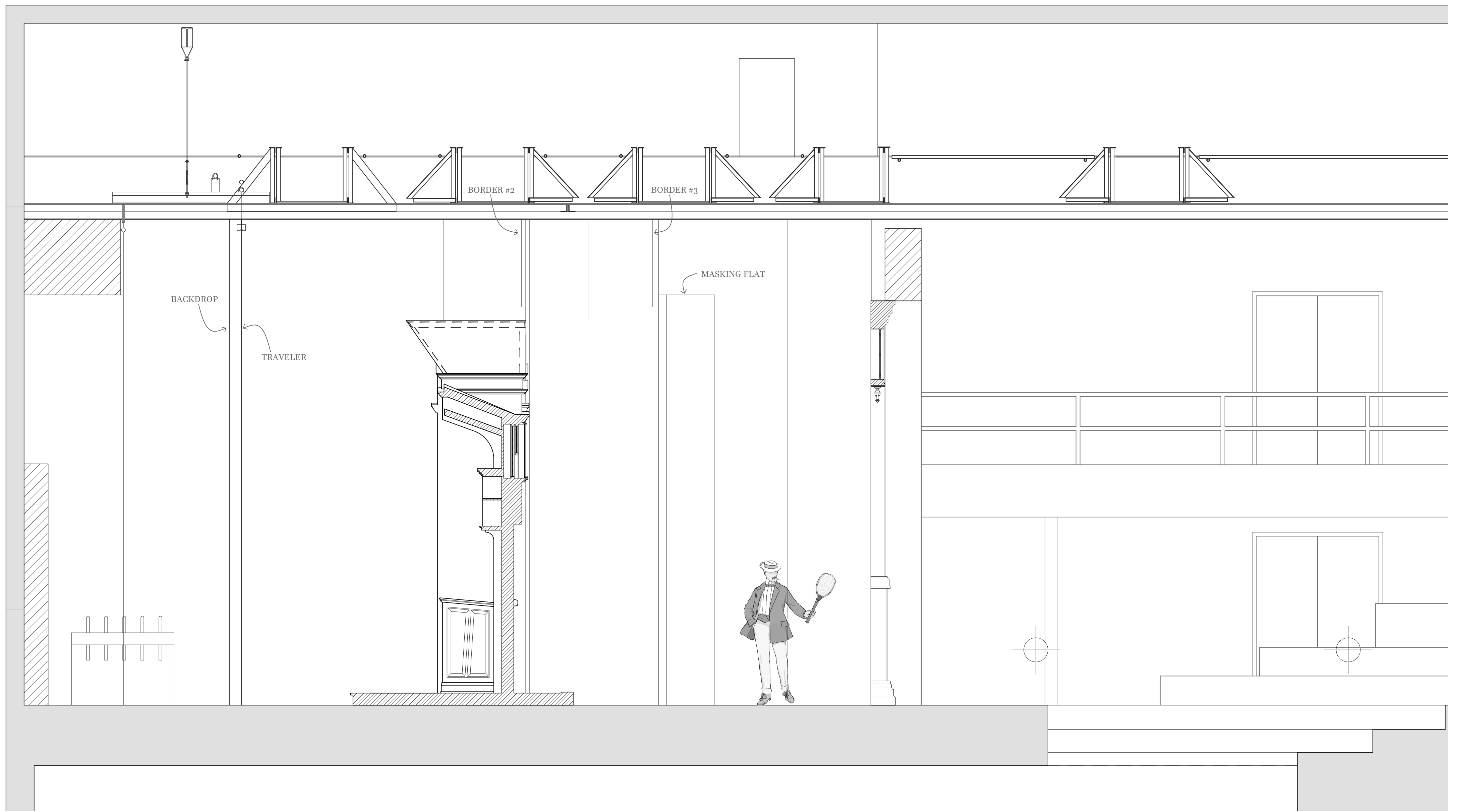

1
5

CASINO SECTION

FOR ESTIMATE ONLY

NOTES:

- MOULDINGS MAY BE SIMPLIFIED FOR READABILITY
- TRIM HEIGHT OF BORDERS IS 16'-6"



COMPOSED BY KIRKE MECHEM
 DIRECTED BY STEPHANIE HAVEY
 SCENERY DESIGNED BY LEO MURPHY
 AGNES DeMILLE THEATER

SCALE: 3/8" = 1'-0"

PLATE NO.
 5 OF 14

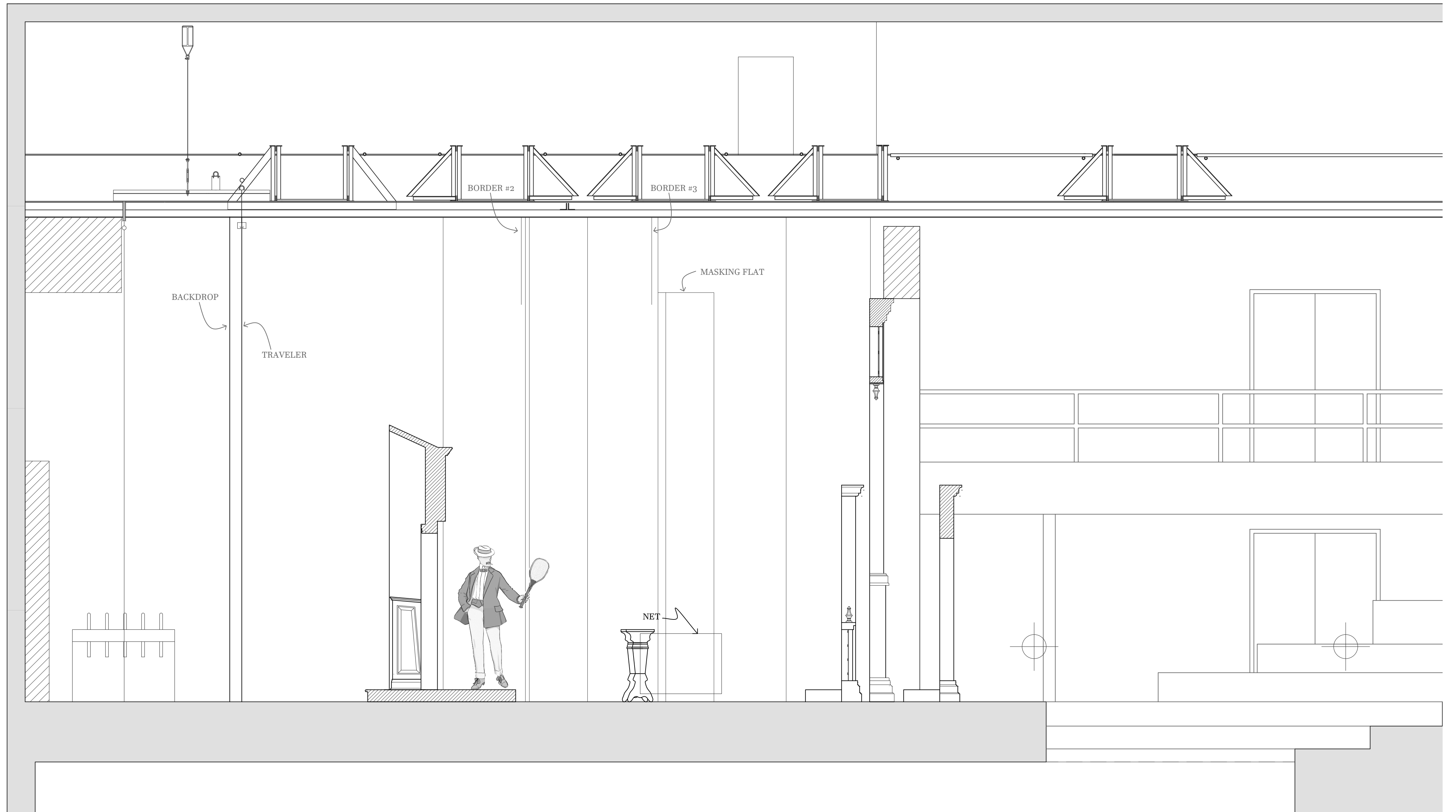

1
6

TENNIS SECTION

FOR ESTIMATE ONLY

NOTES:

- MOULDINGS MAY BE SIMPLIFIED FOR READABILITY
- TRIM HEIGHT OF BORDERS IS 16'-6"
- BOTH POSITIONS OF HEART TRELLIS UNITS ARE REPRESENTED
- TENNIS NET NOT SHOWN IN SECTION



COMPOSED BY KIRKE MECHEM
DIRECTED BY STEPHANIE HAVEY
SCENERY DESIGNED BY LEO MURPHY
AGNES DeMILLE THEATER

SCALE: 3/8" = 1'-0"

PLATE NO.
6 OF 14

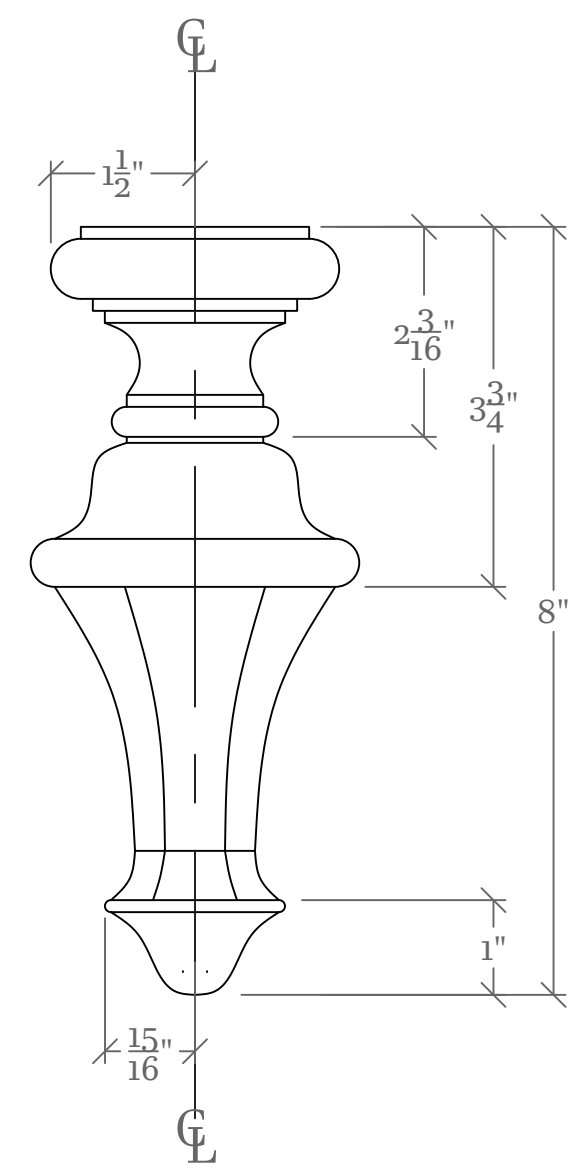

2
7
PENDANT DETAIL
SCALE: 6" = 1'-0"
MAKE 6

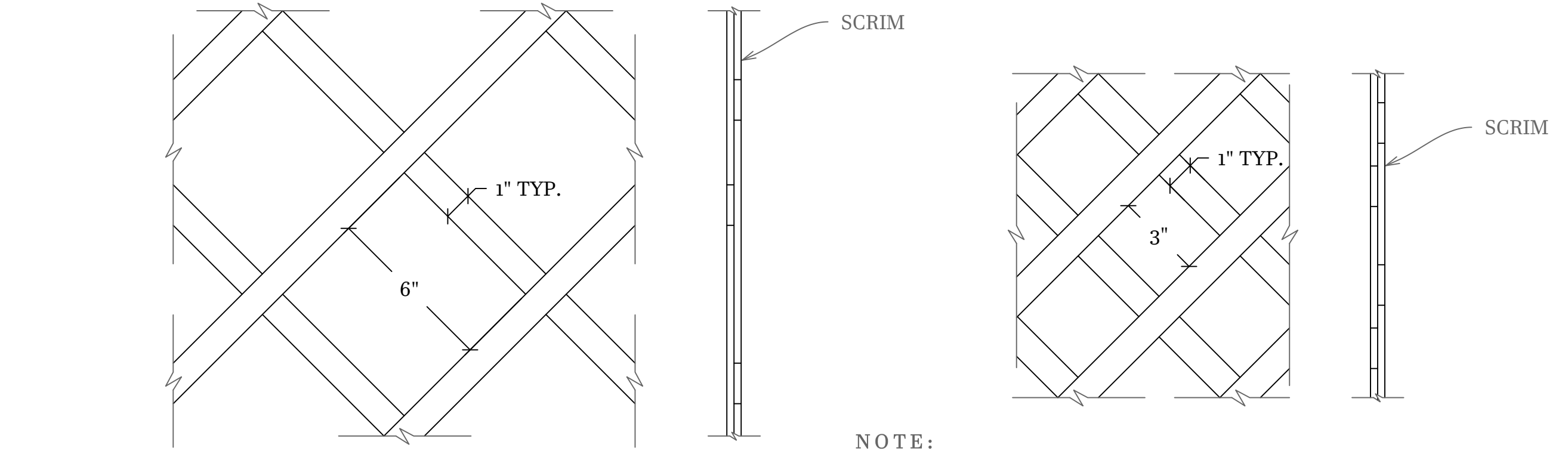

3
7
DIAGONAL LATTICE DETAIL
SCALE: 3" = 1'-0"
NOTE:
• DIRECTION OF LATTICE ON TOP MIRRORED OVER CL. SEE FULL ELEVATION
• COTTON SCRIM ATTACHED DIRECTLY TO BACK OF LATTICE

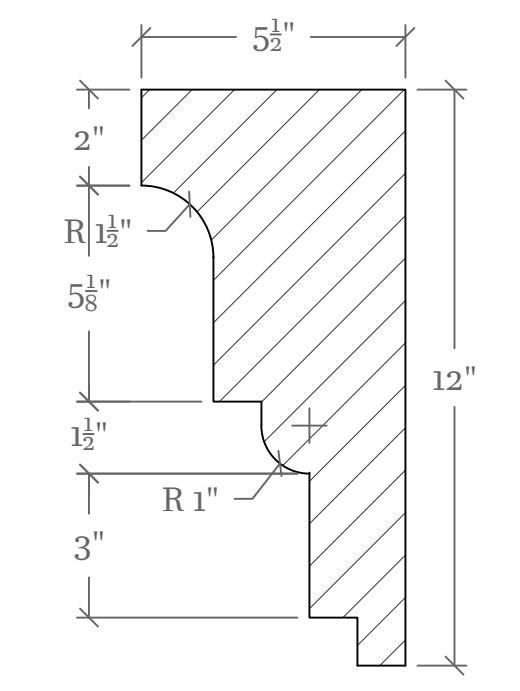

4
7
CROWN MOULDING DETAIL
SCALE: 3" = 1'-0"

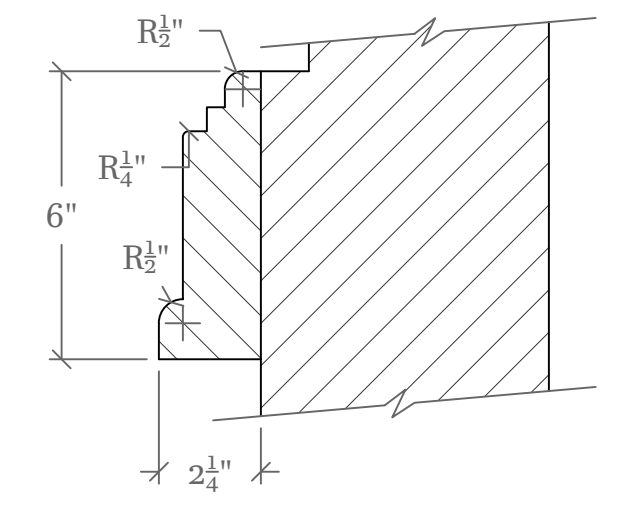
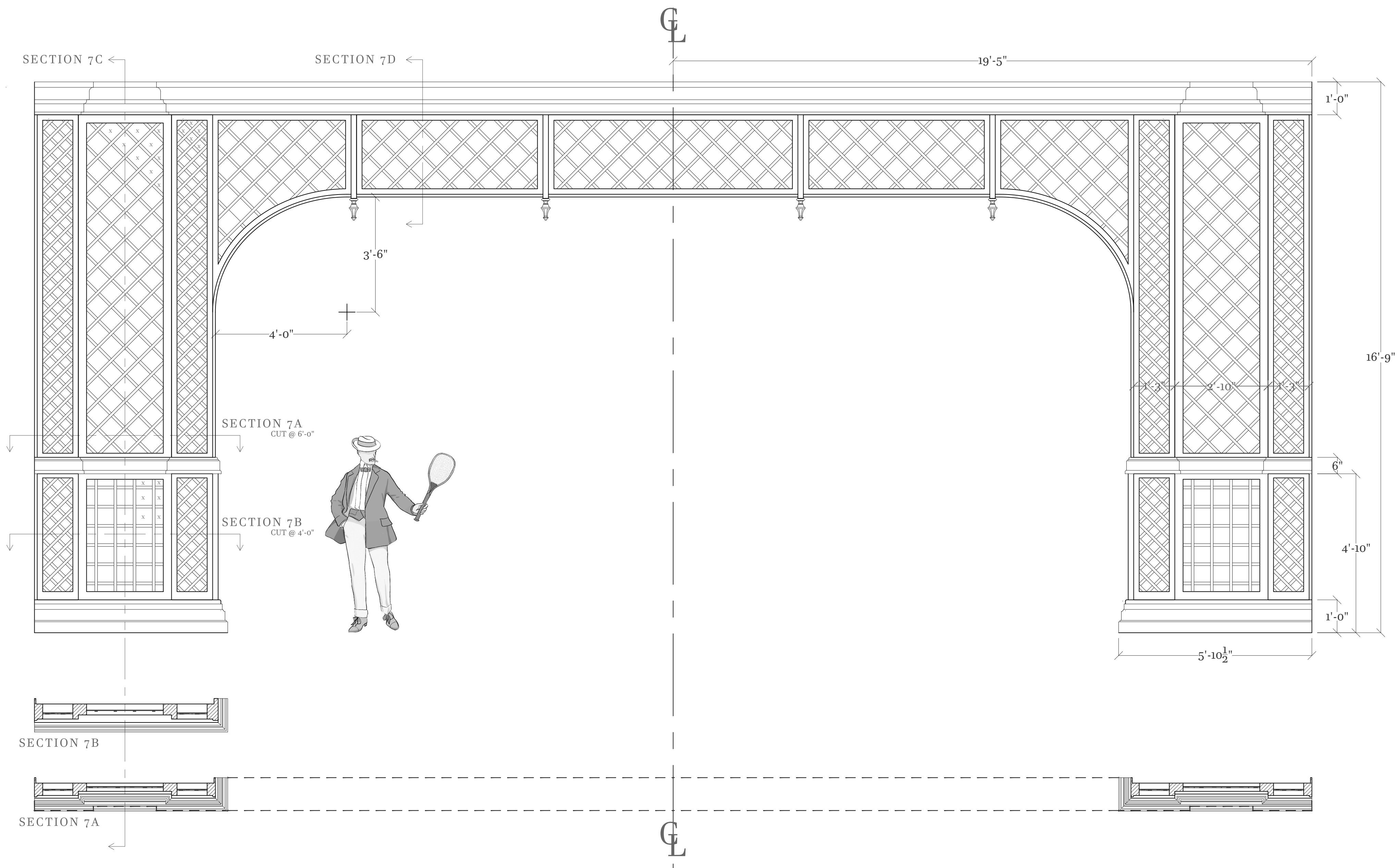
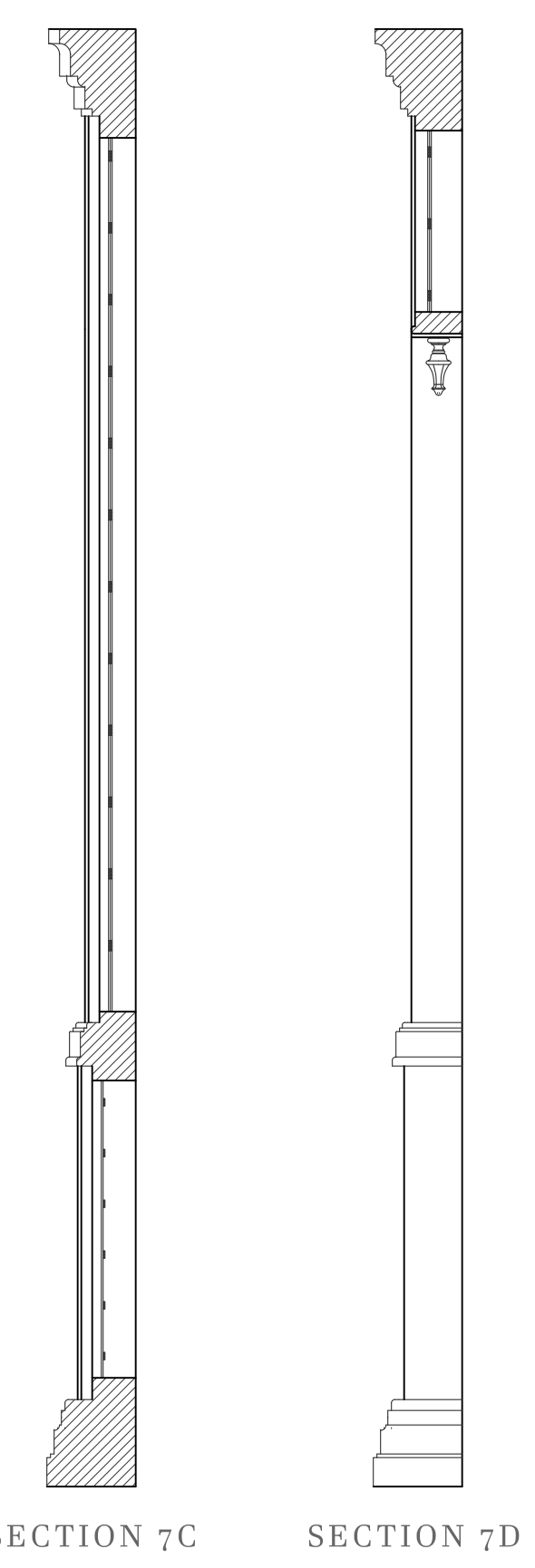

5
7
BASE MOULDING DETAIL
SCALE: 3" = 1'-0"

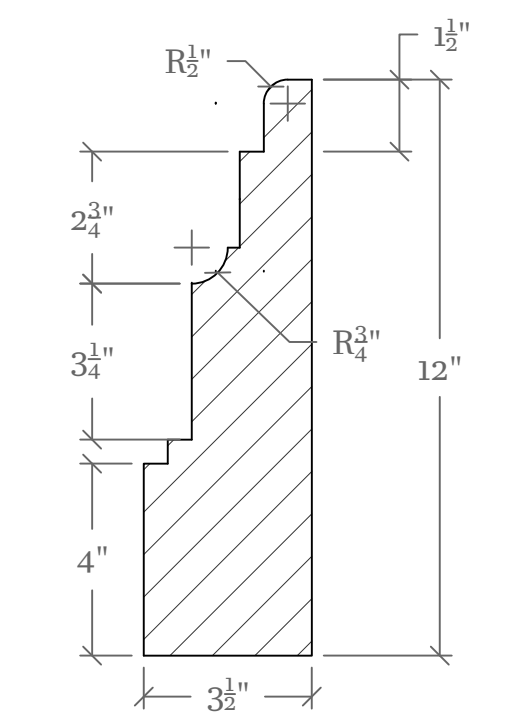

6
7
BASE MOULDING DETAIL
SCALE: 3" = 1'-0"

1
7
LATTICE PROSCENIUM
NOTE:
• LATTICE IS SEE THROUGH, SPACES OPEN BETWEEN BOARDS (AREAS PARTIALLY MARKED WITH X'S BUT NOT FULLY)

FOR ESTIMATE ONLY



COMPOSED BY KIRKE MECHEM
DIRECTED BY STEPHANIE HAYEY
SCENERY DESIGNED BY LEO MURPHY
AGNES DE MILLE THEATER

SCALE: 1/2" = 1'-0"
OR AS NOTED
PLATE NO.
7 OF **14**

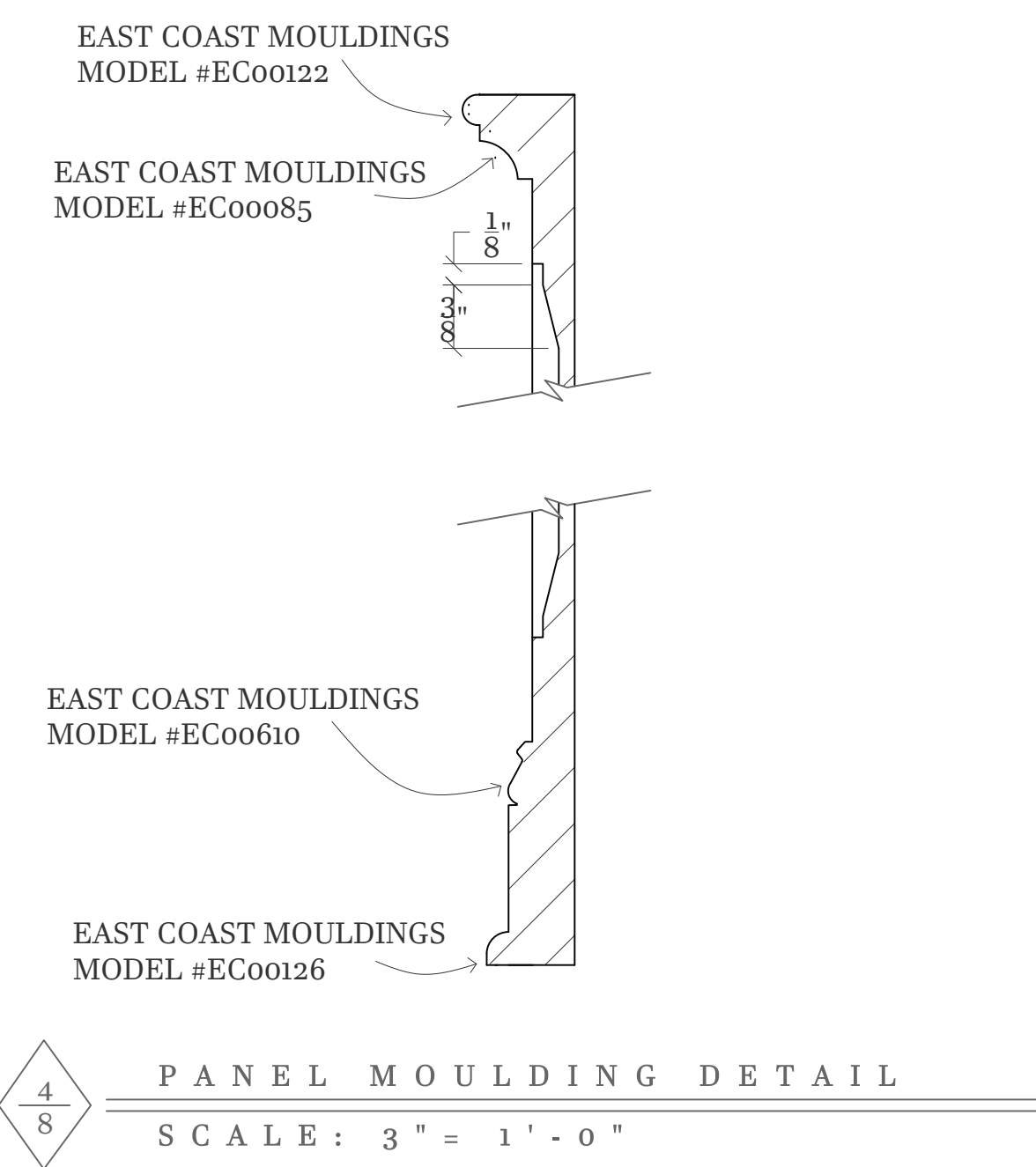
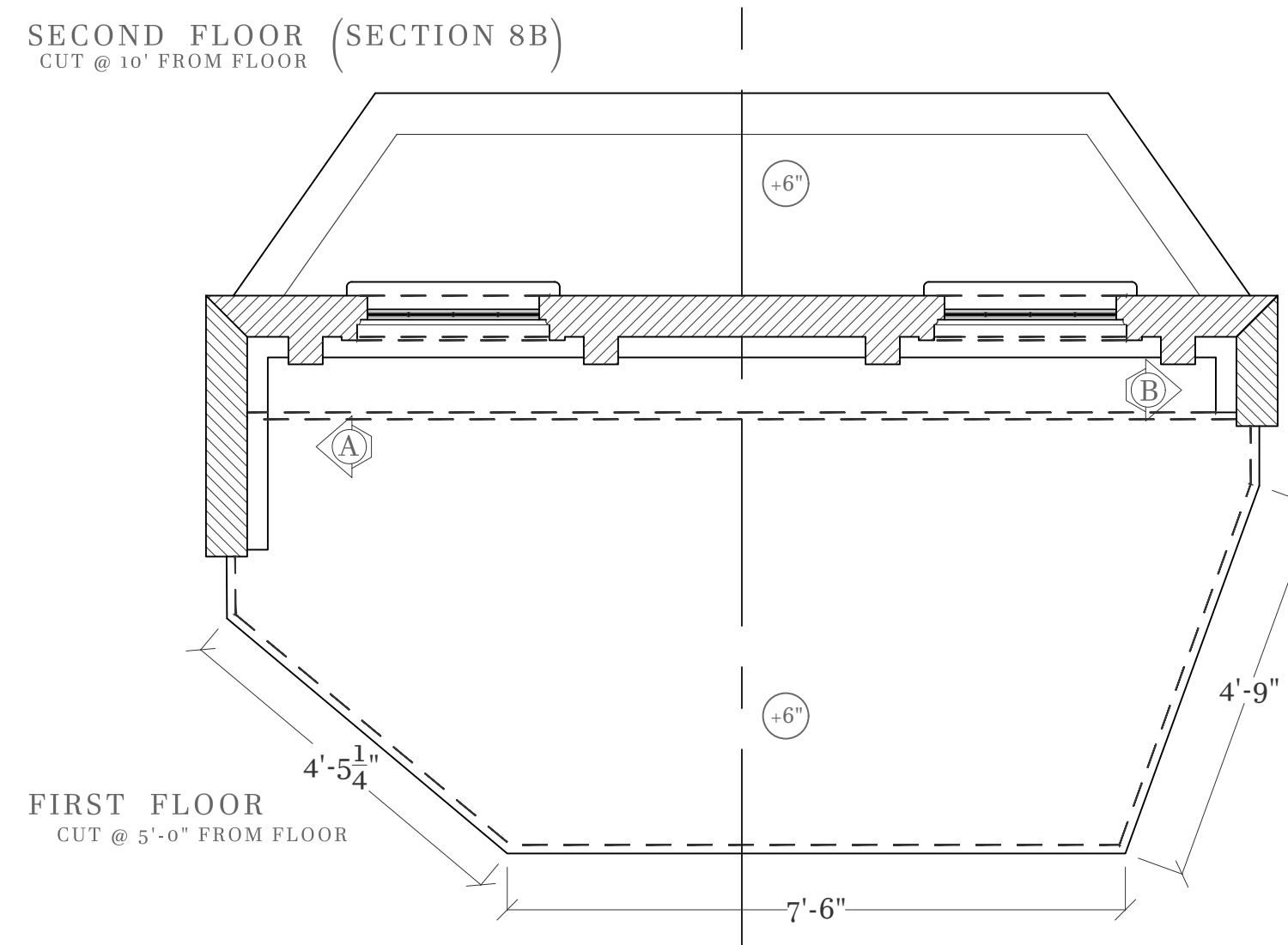
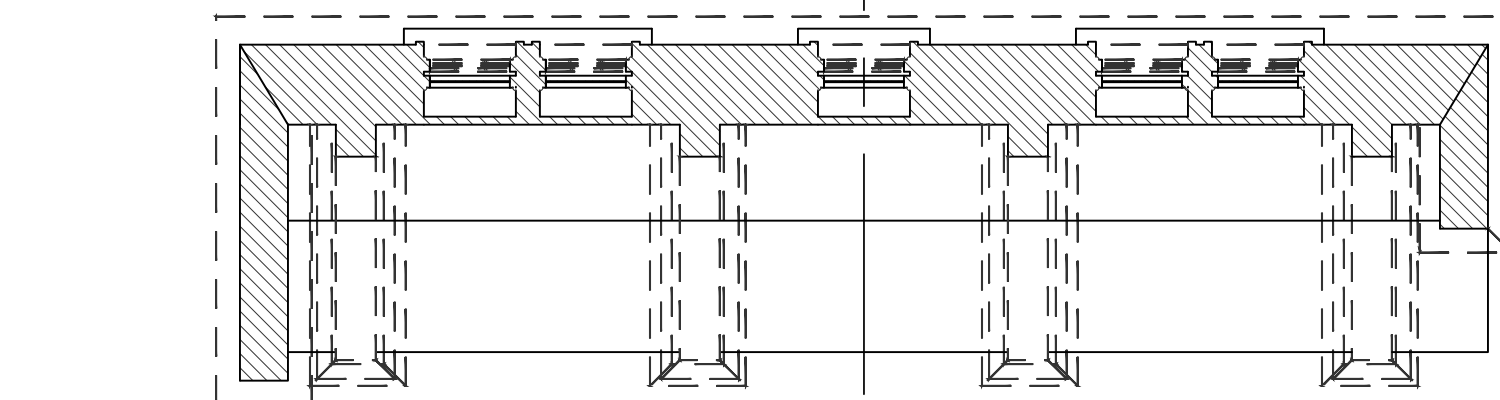
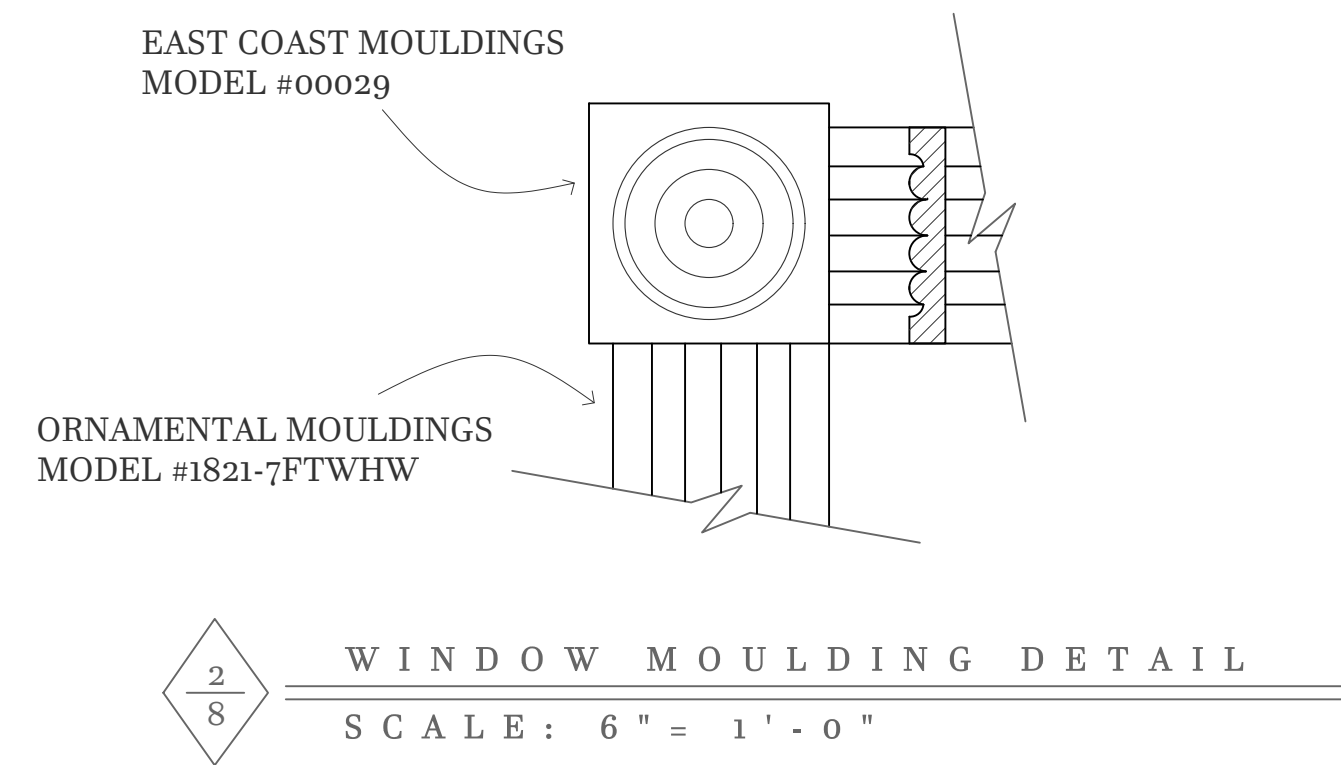
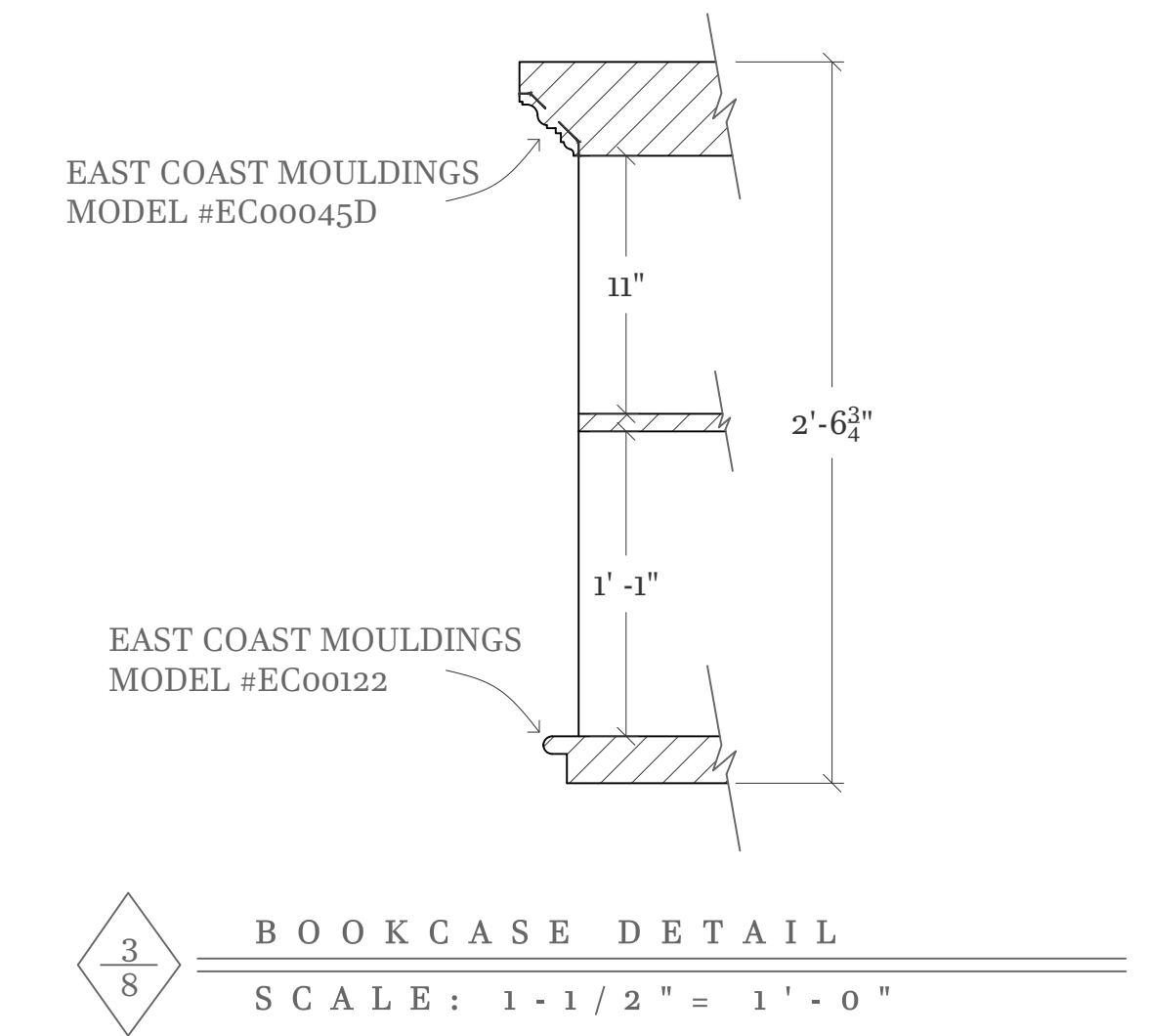
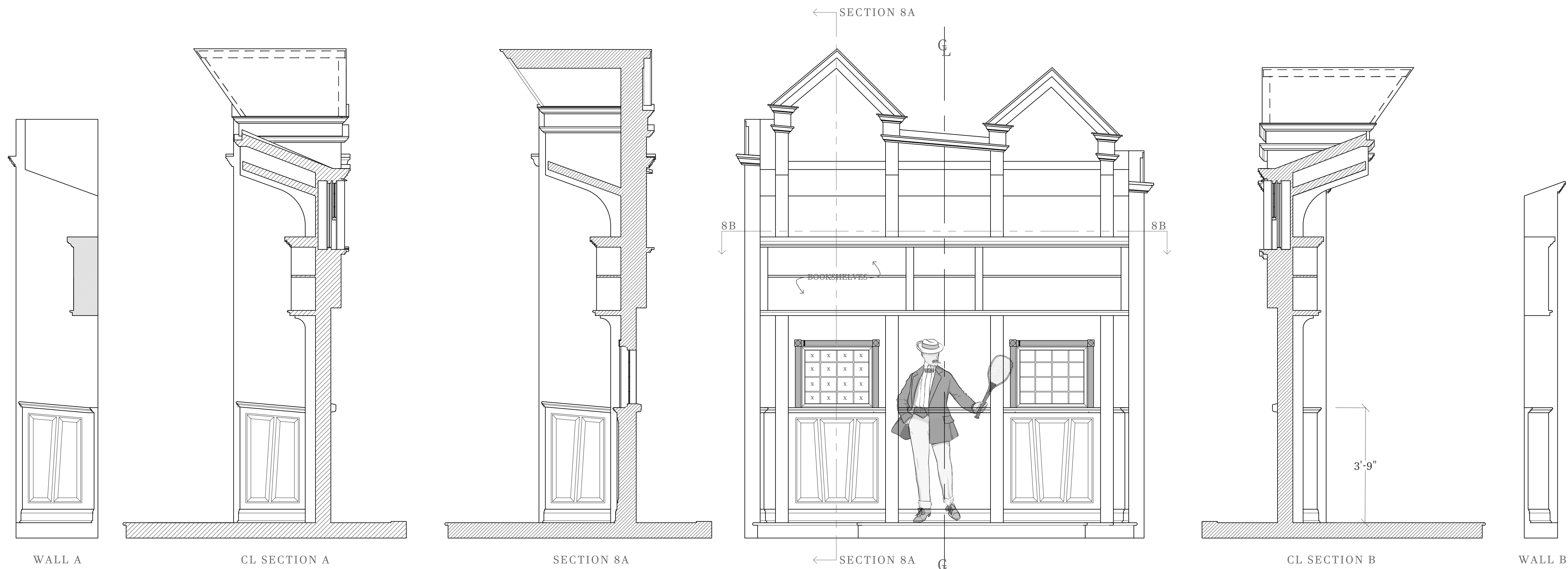

1
8

COMBINED SALON ELEVATION

NOTE:

- MOULDINGS IN PLAN VIEWS ARE SIMPLIFIED FOR EASE OF READING
- X'S IN WINDOWS ARE TYPICAL, NOT ALL HOLES ARE MARKED

FOR ESTIMATE ONLY



COMPOSED BY KIRKE MECHEM
DIRECTED BY STEPHANIE HAVEY
SCENERY DESIGNED BY LEO MURPHY
AGNES DE MILLE THEATER

SCALE: 1/2" = 1'-0"
OR AS NOTED

PLATE NO.
8 OF 14

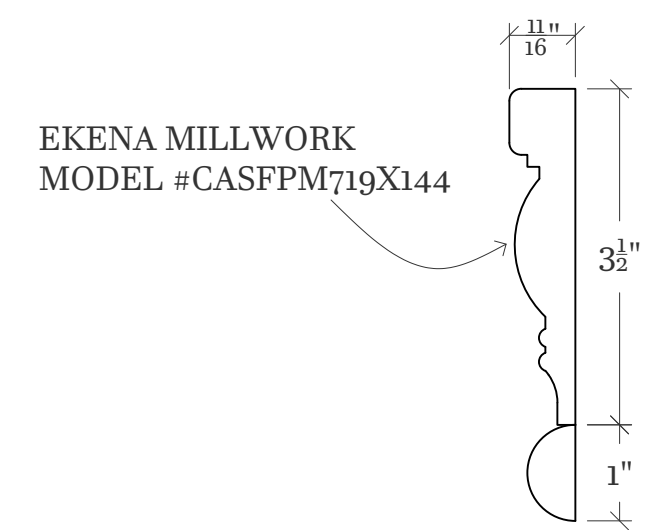
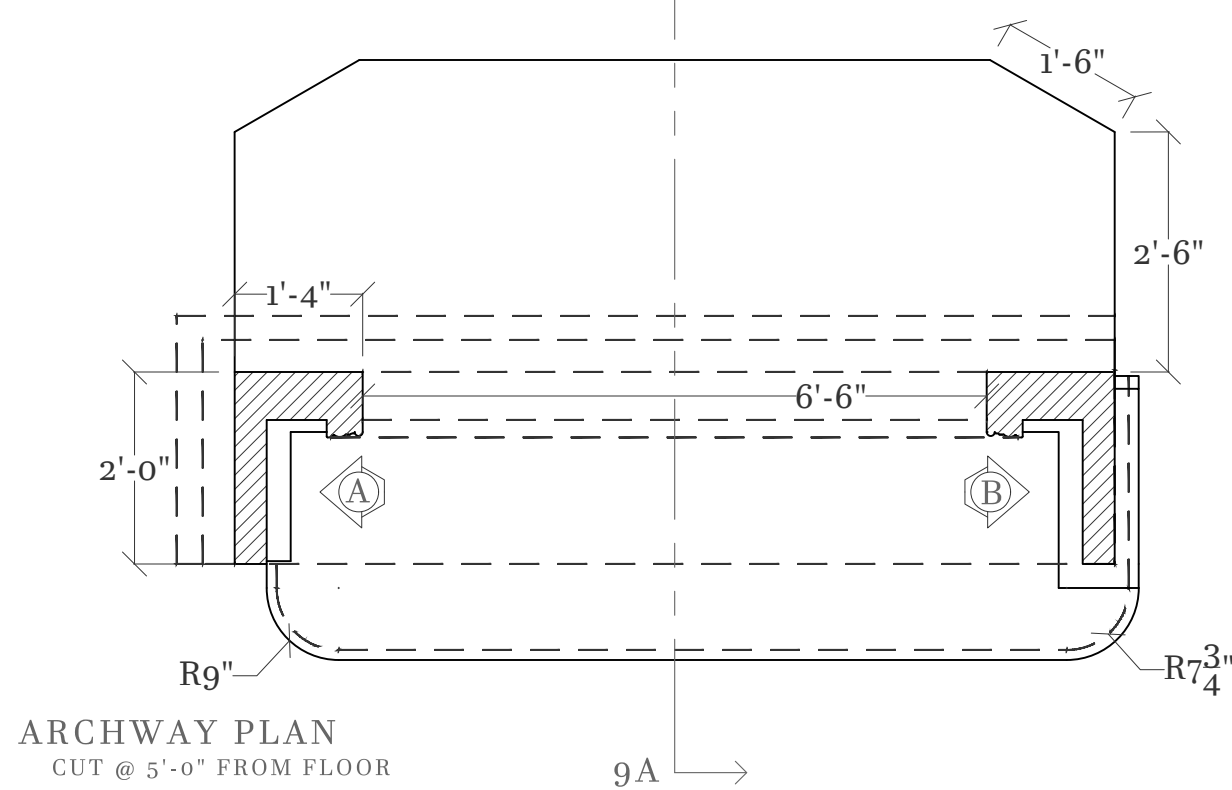
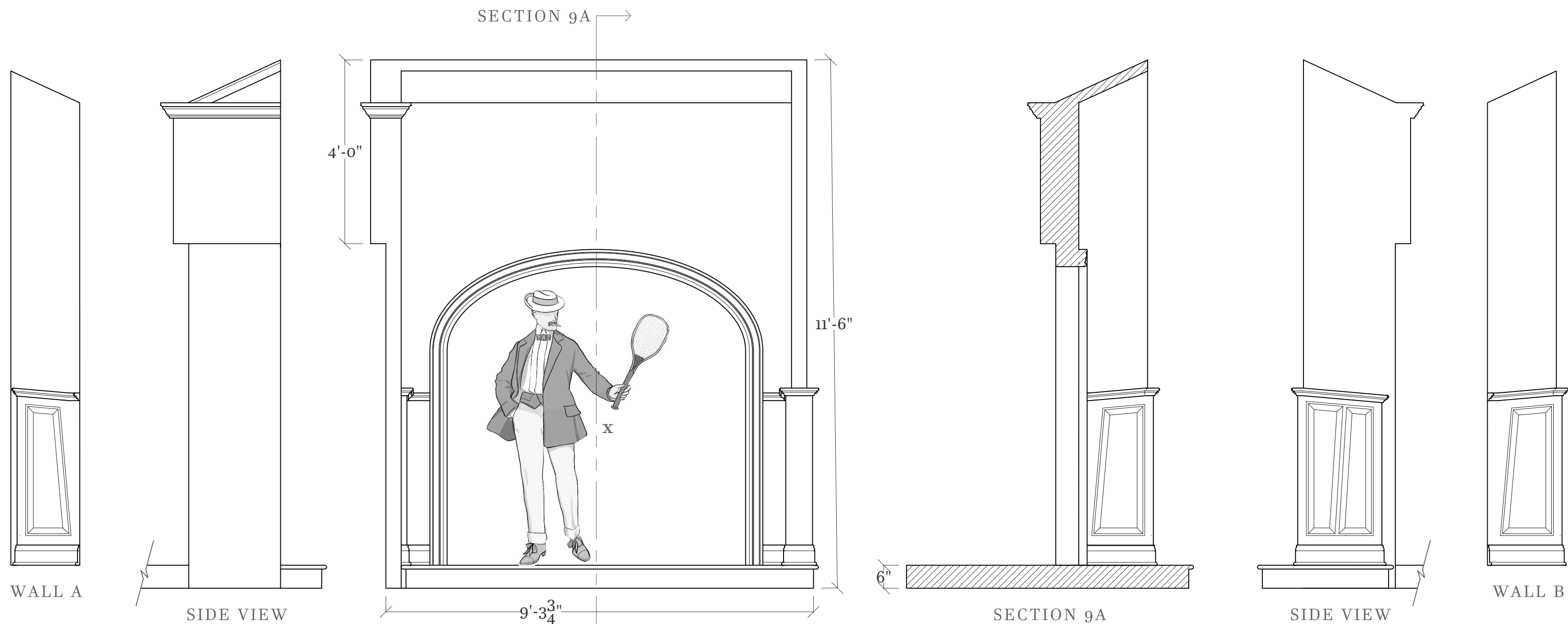

2
9 ARCHWAY MOULDING DETAIL
SCALE: 1 - 1/2" = 1' - 0"

NOTE:

- MOULDINGS IN PLAN VIEWS ARE SIMPLIFIED FOR EASE OF READING
- ARCHWAY IS OPEN THROUGH TO OTHER SIDE
- SEE PLATE NO.8 FOR PANEL MOULDING DETAIL

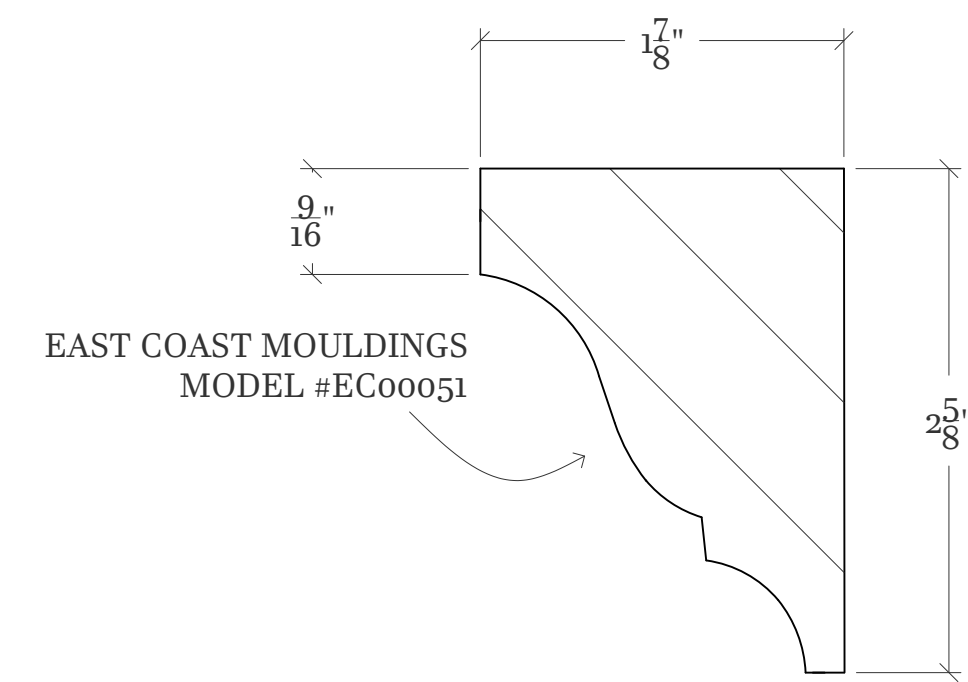
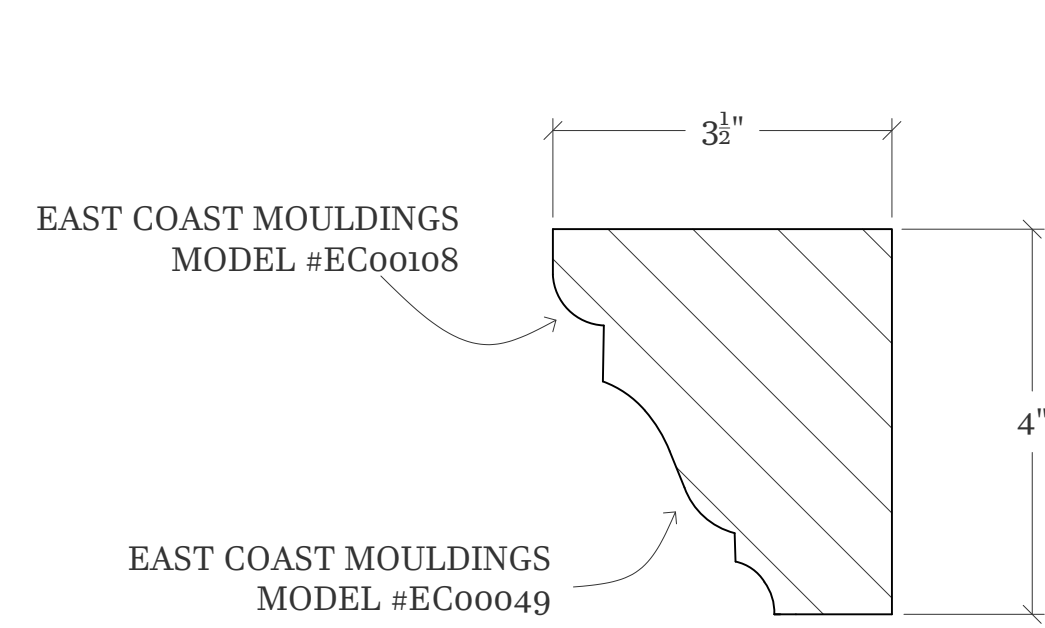

2
10 SECOND FLOOR TRIM
SCALE: 1-1/2" = 1'-0"

3
10 ROOFLINE TRIM
SCALE: 1:1

NOTE:

- HEIGHTS OF 2ND FLOOR WINDOW PANELS AND TRIM VARY ALONG WALL FOLLOWING ANGLED MOULDINGS (SEE ELEVATION)
- WINDOWS ARE STATIC AND DO NOT FUNCTION
- PLANTER BOXES TO BE PLACED ON WINDOWSILLS AND FLAGS HUNG FROM FRONT EDGE
- 2ND FLOOR WINDOWS OBSTRUCTED ON INTERIOR SIDE, DISCUSS WITH DESIGNER AND PROPS DIRECTOR
- SEE NOTE ABOUT SCREEN BELOW

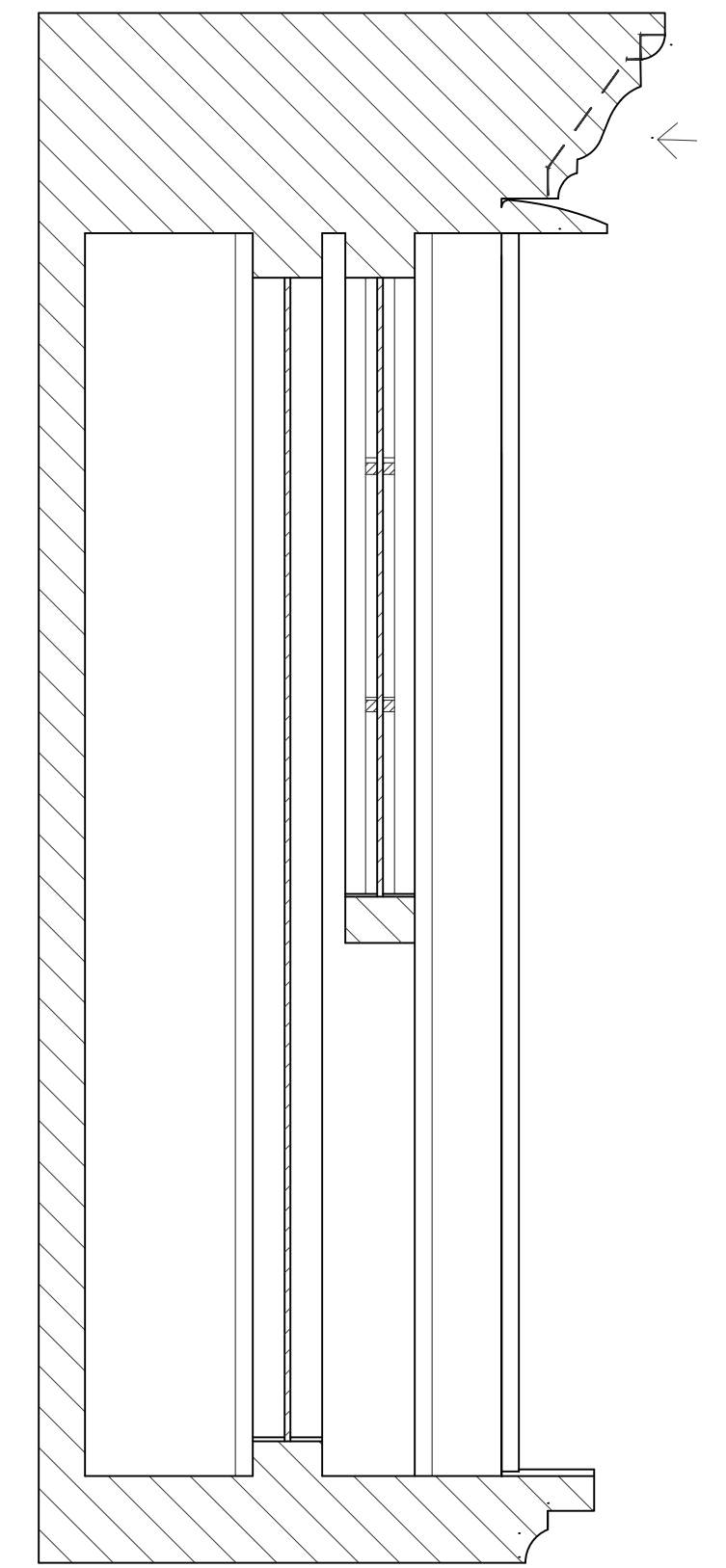

4
10 2ND FLOOR WINDOW DETAIL
SCALE: 3" = 1'-0"

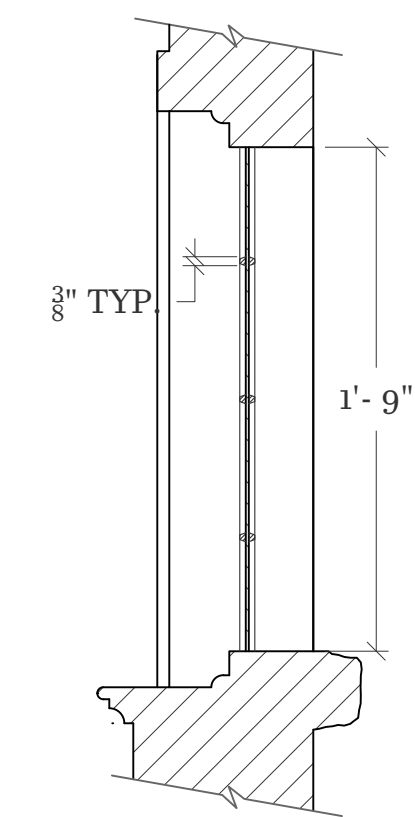
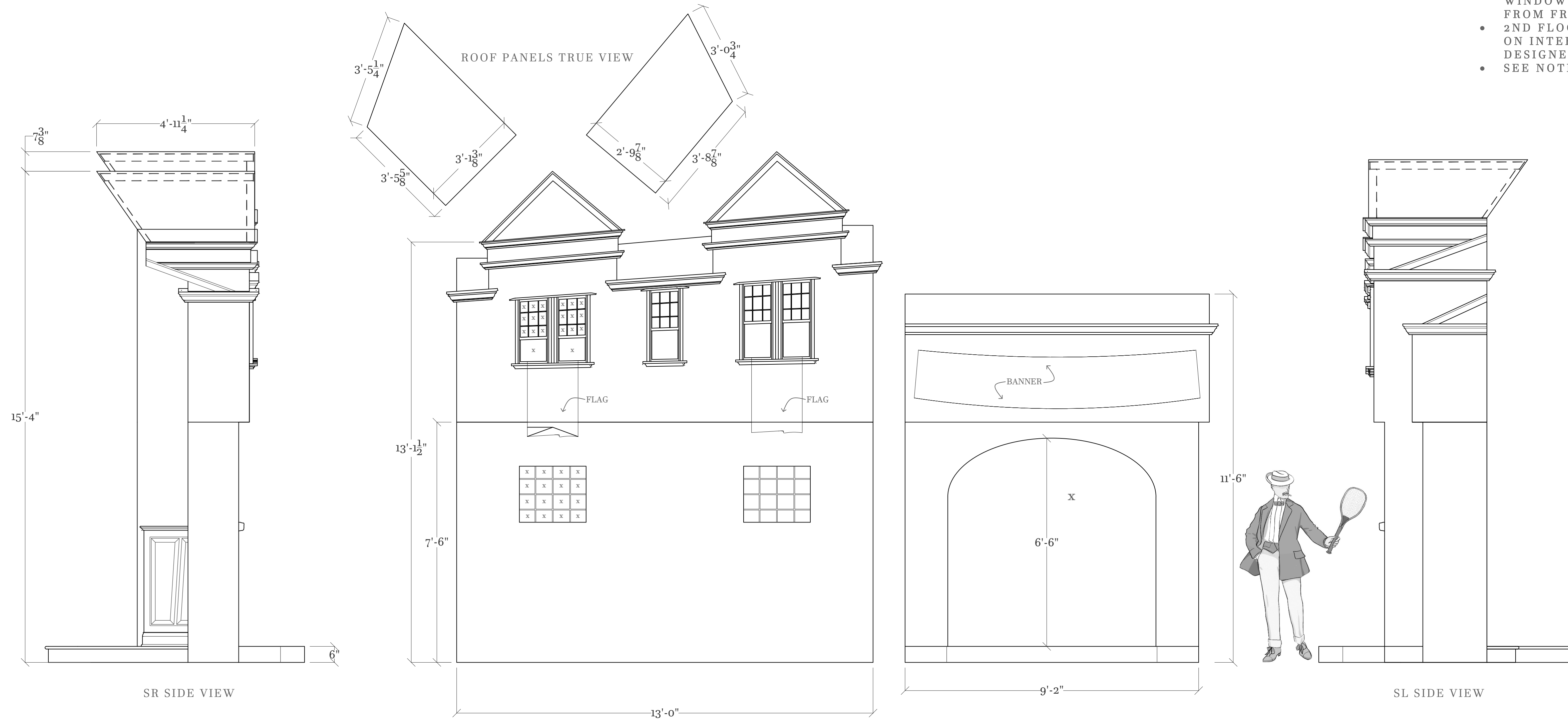

NOTE:

- 1ST FLOOR WINDOWS ARE IDENTICAL
- "GLASS" REPLACED WITH SCREEN, DISCUSS MATERIAL/COLOR WITH DESIGNER

5
10 1ST FLOOR WINDOW DETAIL
SCALE: 1-1/2" = 1'-0"

1
10 COMBINED CASINO ELEVATION
NOTE:

- MOULDINGS IN PLAN VIEWS ARE SIMPLIFIED FOR EASE OF READING
- X'S IN WINDOWS ARE TYPICAL, NOT ALL HOLES ARE MARKED
- THICKNESS OF STONE TEXTURE IS INCLUDED IN 6" WALL THICKNESS FOR FIRST FLOOR
- SEE PLATE NO.11 FOR APPLIED SHINGLES AND STONE
- SEE PLATE NO.8 FOR PLAN VIEWS

FOR ESTIMATE ONLY

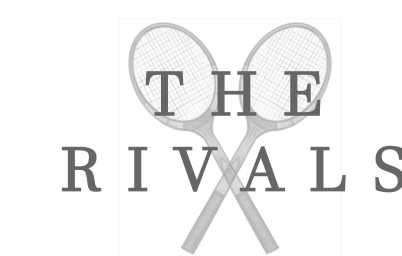

COMPOSED BY KIRKE MECHEM
DIRECTED BY STEPHANIE HAVEY
SCENERY DESIGNED BY LEO MURPHY
AGNES DeMILLE THEATER

SCALE: 1/2" = 1'-0"
OR AS NOTED

PLATE NO.
10 OF 14

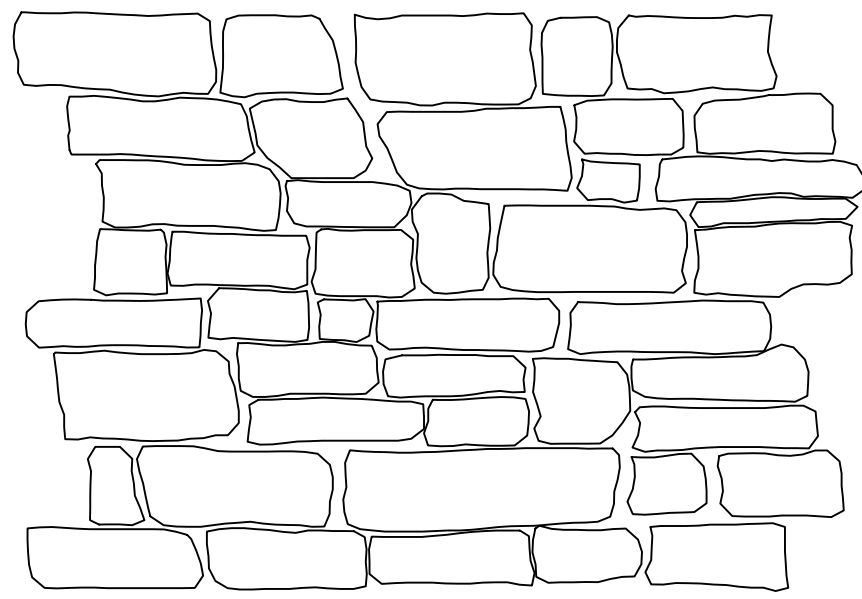

NOTES:

- PAS003 VERY CUT STONE FROM PULP ART SURFACES
- NOT ALL STONES FOLLOW PATTERN, MARKED STONES ARE CUSTOM AROUND ARCHWAY AND WINDOWS
- THICKNESS OF STONE IS FACTORED INTO 6" TOTAL WIDTH OF LOWER WALLS

2
11

STONE PATTERN
SCALE: 3/4" = 1'-0"

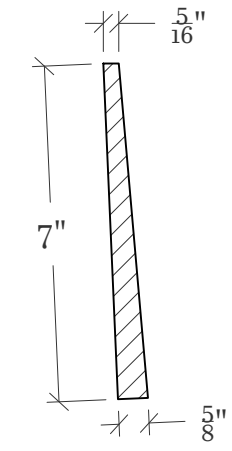

NOTES:

- BOTTOM ROW OF SHINGLES SHORTENED, SEE ELEVATIONS BELOW
- MOST SHINGLES, WITH EXCEPTION OF THOSE ON EDGES ARE IN WIDTHS OF 4", 6", & 8"

3
11

SHINGLE SECTION
SCALE: 3" = 1'-0"



1
11

STONE AND SHINGLE LAYOUT

FOR ESTIMATE ONLY



COMPOSED BY KIRKE MECHEM
DIRECTED BY STEPHANIE HAVEY
SCENERY DESIGNED BY LEO MURPHY
AGNES DeMILLE THEATER

SCALE: 1/2" = 1'-0"
OR AS NOTED

PLATE NO.
11 OF 14

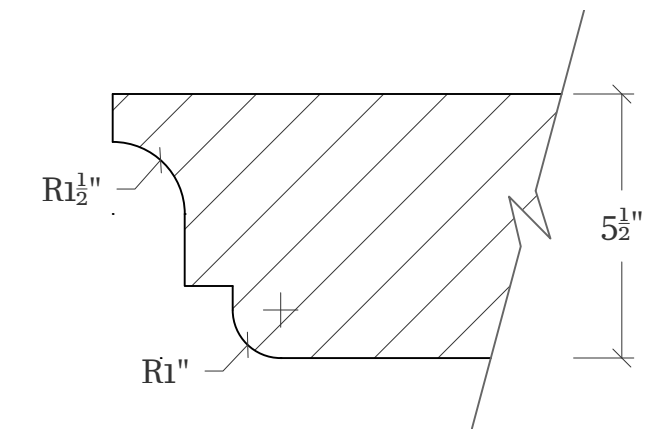
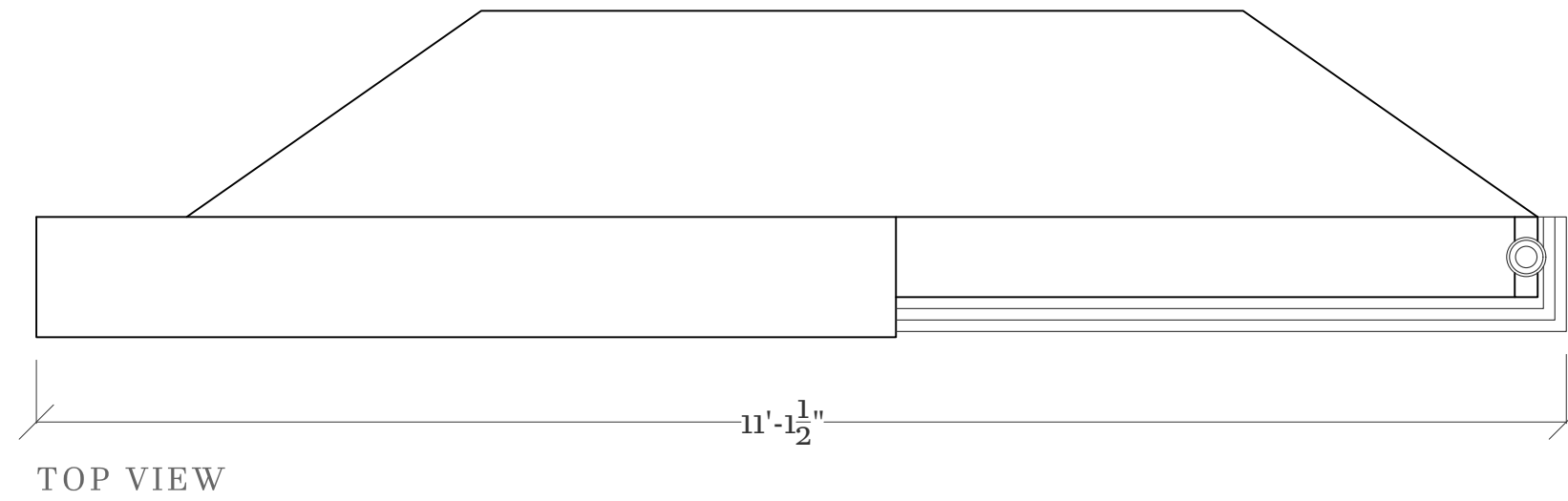

2
12
CROWN MOULDING DETAIL
SCALE: 3" = 1'-0"

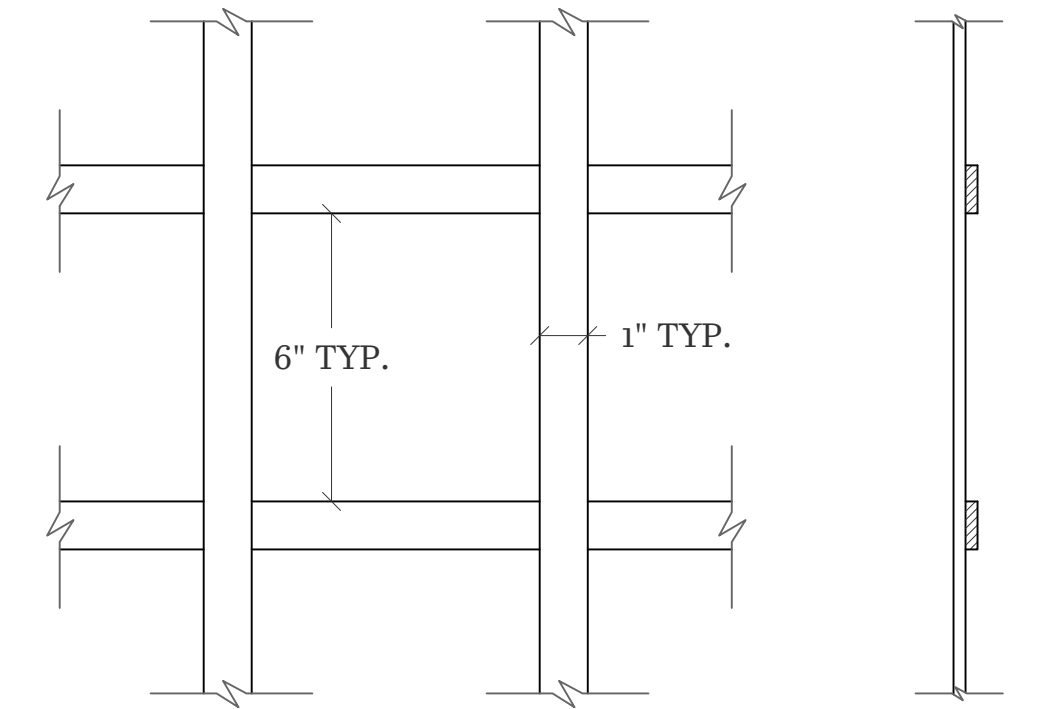
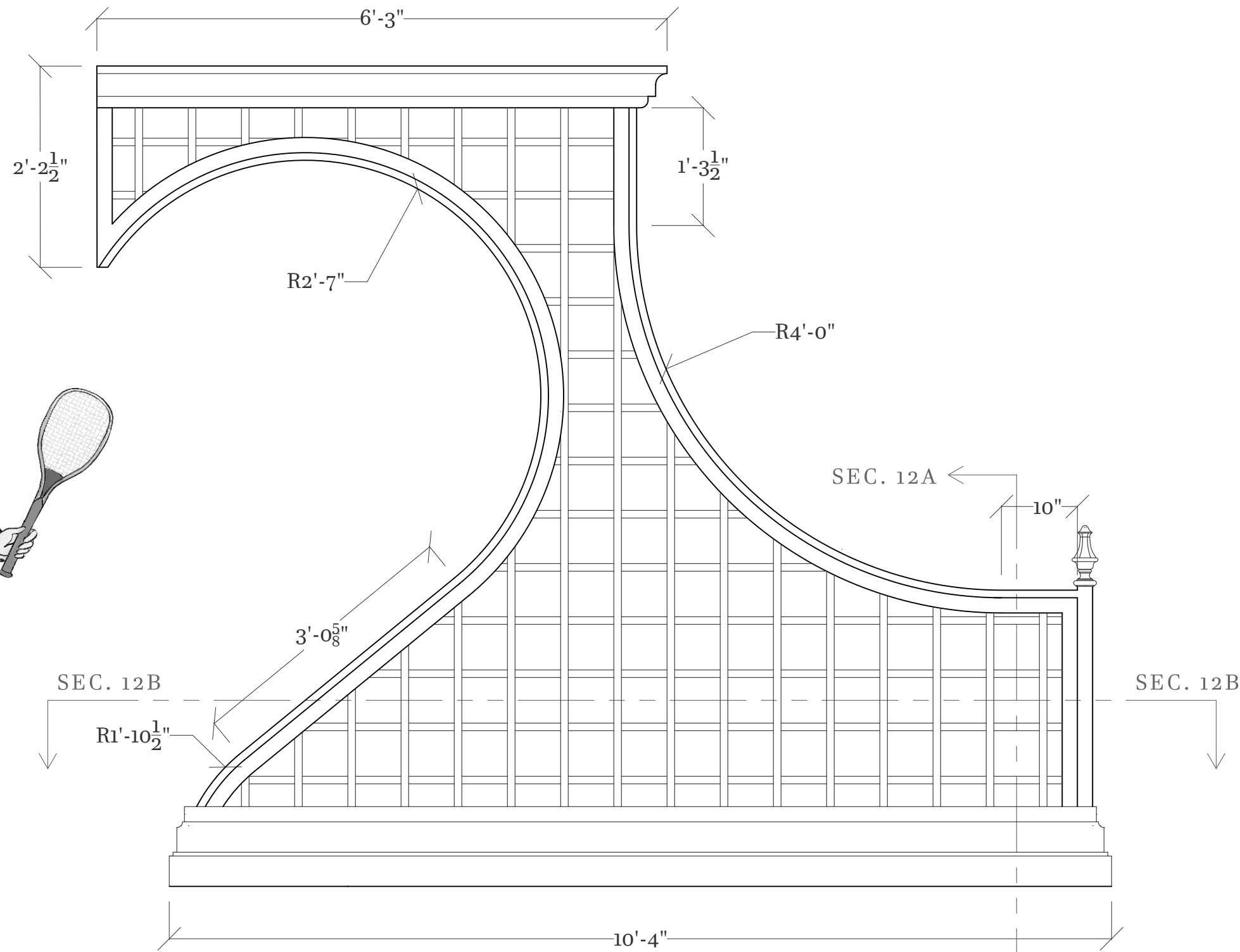
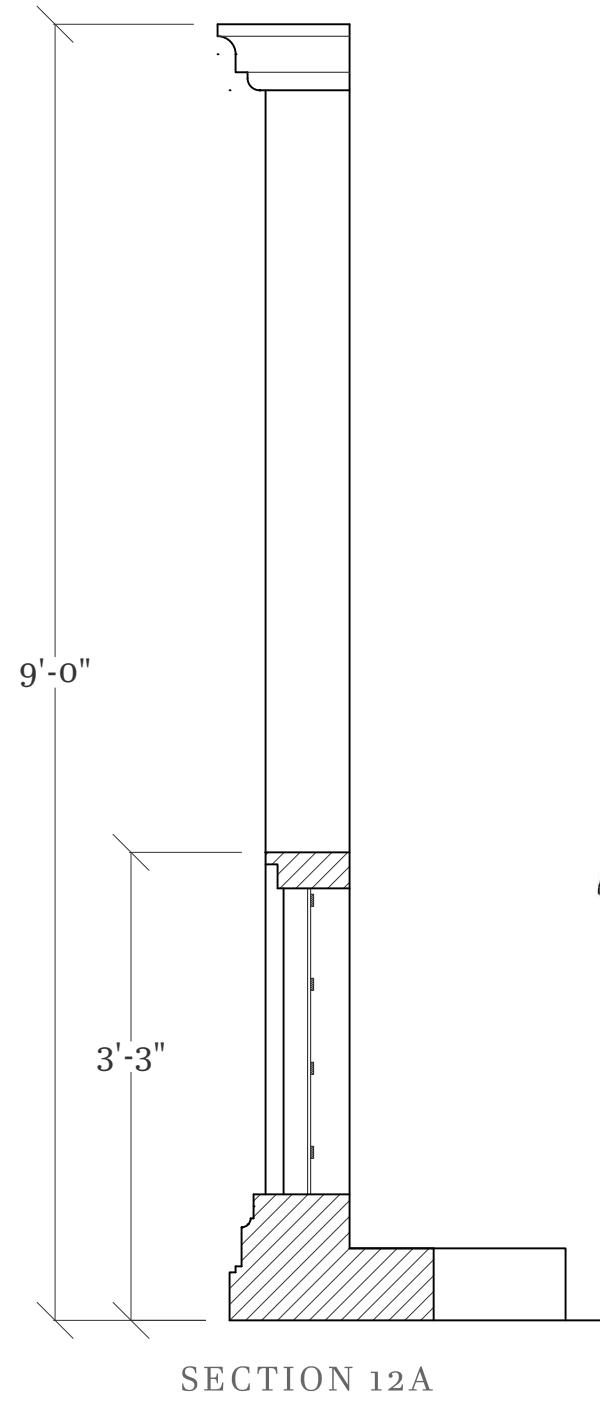

3
12
LATTICE DETAIL
SCALE: 3" = 1'-0"

- NOTES:**
- UNITS MADE TO LOOK LIKE SAME WOODEN MATERIAL AS PROSCENIUM
 - LATTICE IS NOT BACKED WITH SCRIM
 - WAGON BEHIND UNITS FOR STABILITY, COUNTERWEIGHT AND DRESSING TO BE ADDED BEHIND TRELLIS
 - FINIAL SHOWN IS SAME AS PROSCENIUM PENDANTS, SEE PLATE NO.7 FOR DETAIL

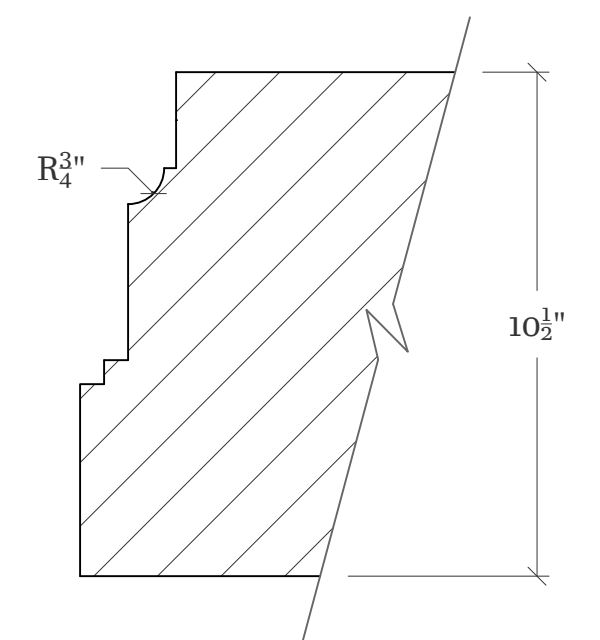
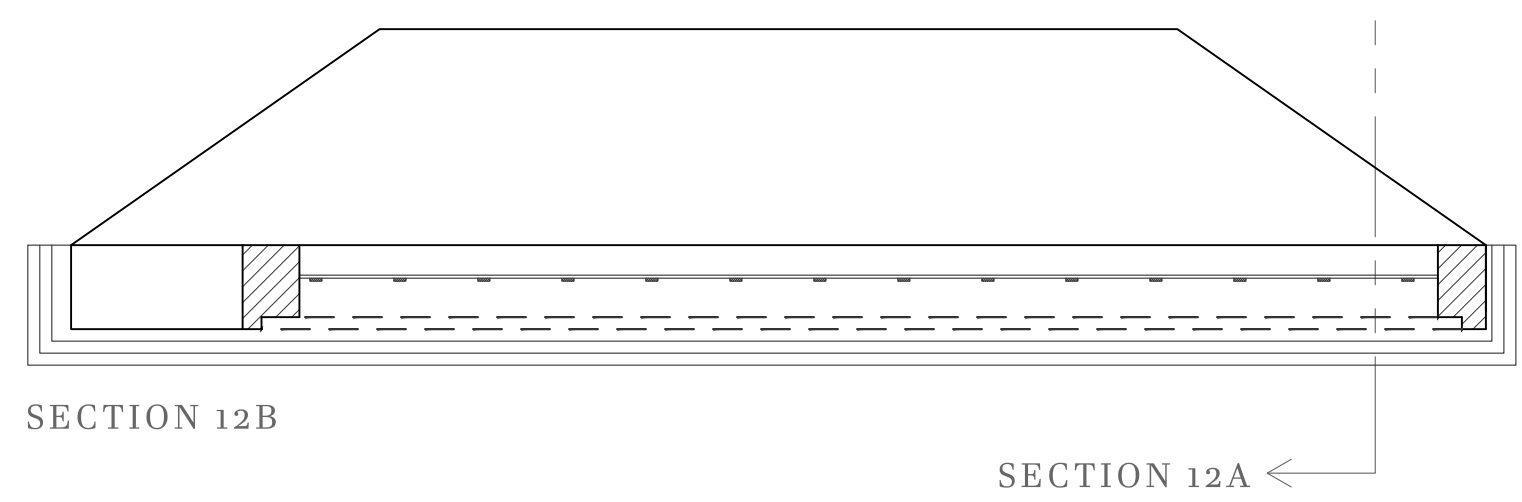

4
12
BASE MOULDING DETAIL
SCALE: 3" = 1'-0"

1
12
HEART TRELLIS UNITS
BUILD 2 - MIRRORED IMAGE OF EACH OTHER

FOR ESTIMATE ONLY



COMPOSED BY KIRKE MECHEM
DIRECTED BY STEPHANIE HAVEY
SCENERY DESIGNED BY LEO MURPHY
AGNES DeMILLE THEATER

SCALE: 3/4" = 1'-0"
OR AS NOTED

PLATE NO.
12 OF 14

NOTES:

- SIZE OF PROSCENIUM SCRIM INCLUDES THE ENTIRE AREA TRELLIS COVERS, INCLUDING MOULDINGS IN BETWEEN
- ONCE LINED UP & INSTALLED, EXCESS MATERIAL AROUND EDGES TO BE CUT OFF

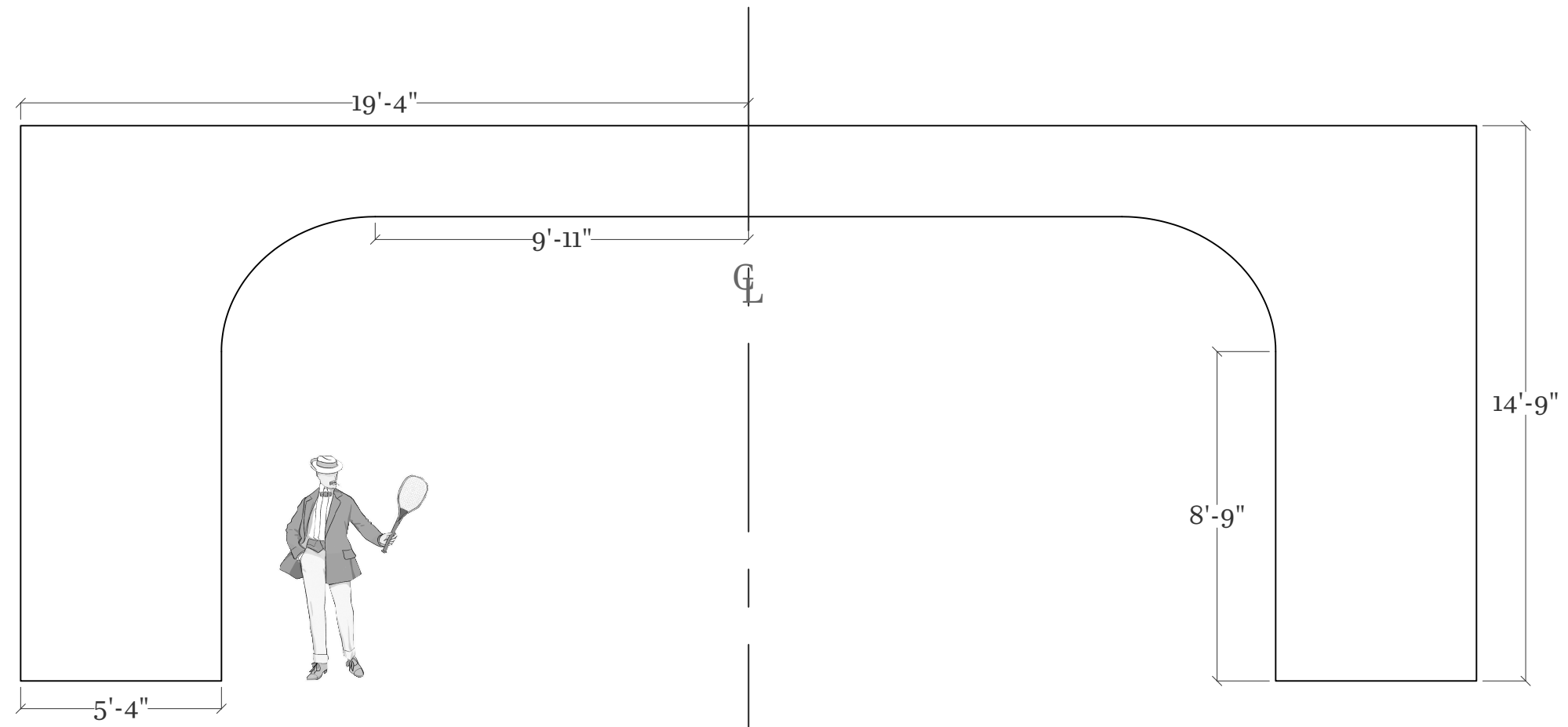

3
13 PRO . SCRIM LAYOUT

NOTES:

- MASKING FLAT WRAPPED IN MUSLIN TO MATCH BACKDROP, APPEAR SEAMLESS AROUND ONSTAGE EDGES
- PLACE BLACK MASKING BEHIND FLATS UP TO HEIGHT OF CATWALKS ABOVE, DISCUSS WITH DESIGNER

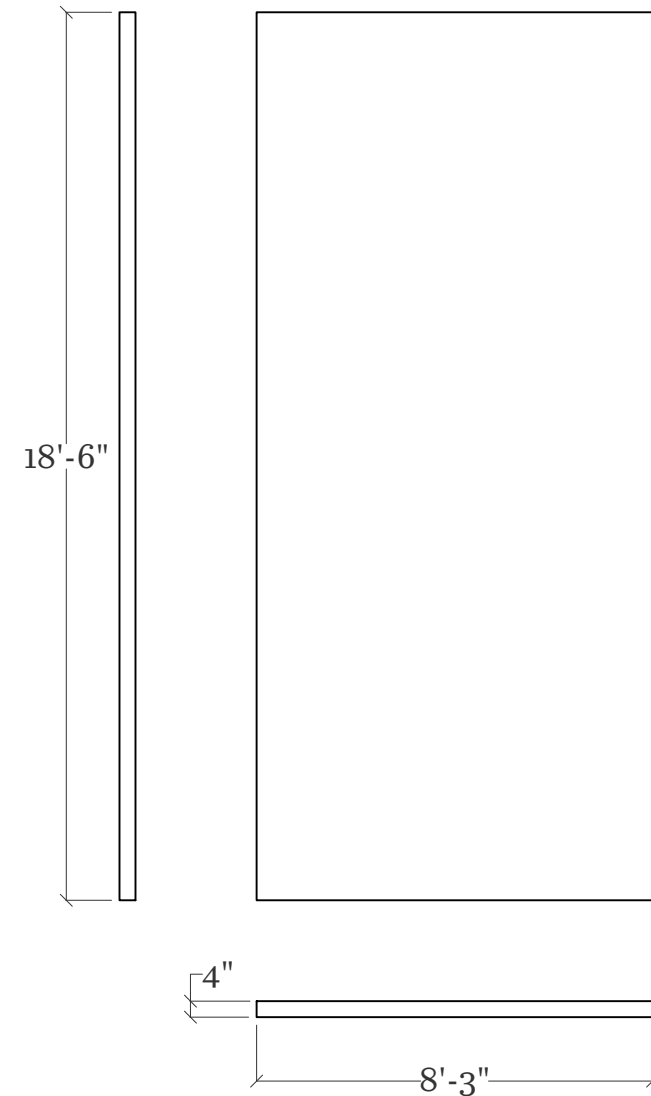

1
13 MASKING FLAT LAYOUT
BUILD 2

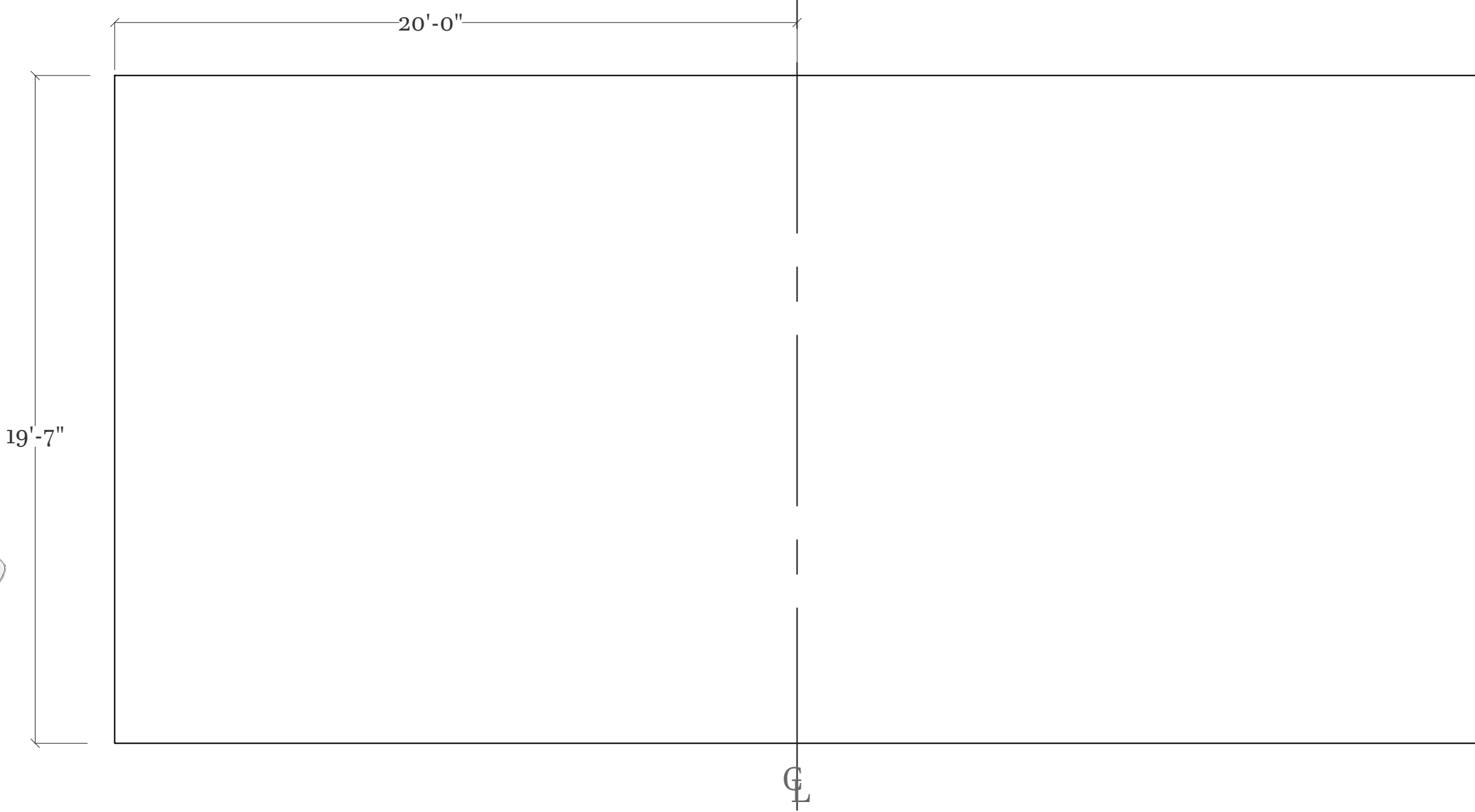

2
13 BACKDROP LAYOUT
HEIGHT OF BACKDROP IS UP TO CATWALKS, DISCUSS WAYS TO ATTACH WITH DESIGNER.

FOR ESTIMATE ONLY



COMPOSED BY KIRKE MECHEM
DIRECTED BY STEPHANIE HAVEY
SCENERY DESIGNED BY LEO MURPHY
AGNES DeMILLE THEATER

SCALE: 1/4" = 1'- 0"

PLATE NO.
13 OF 14

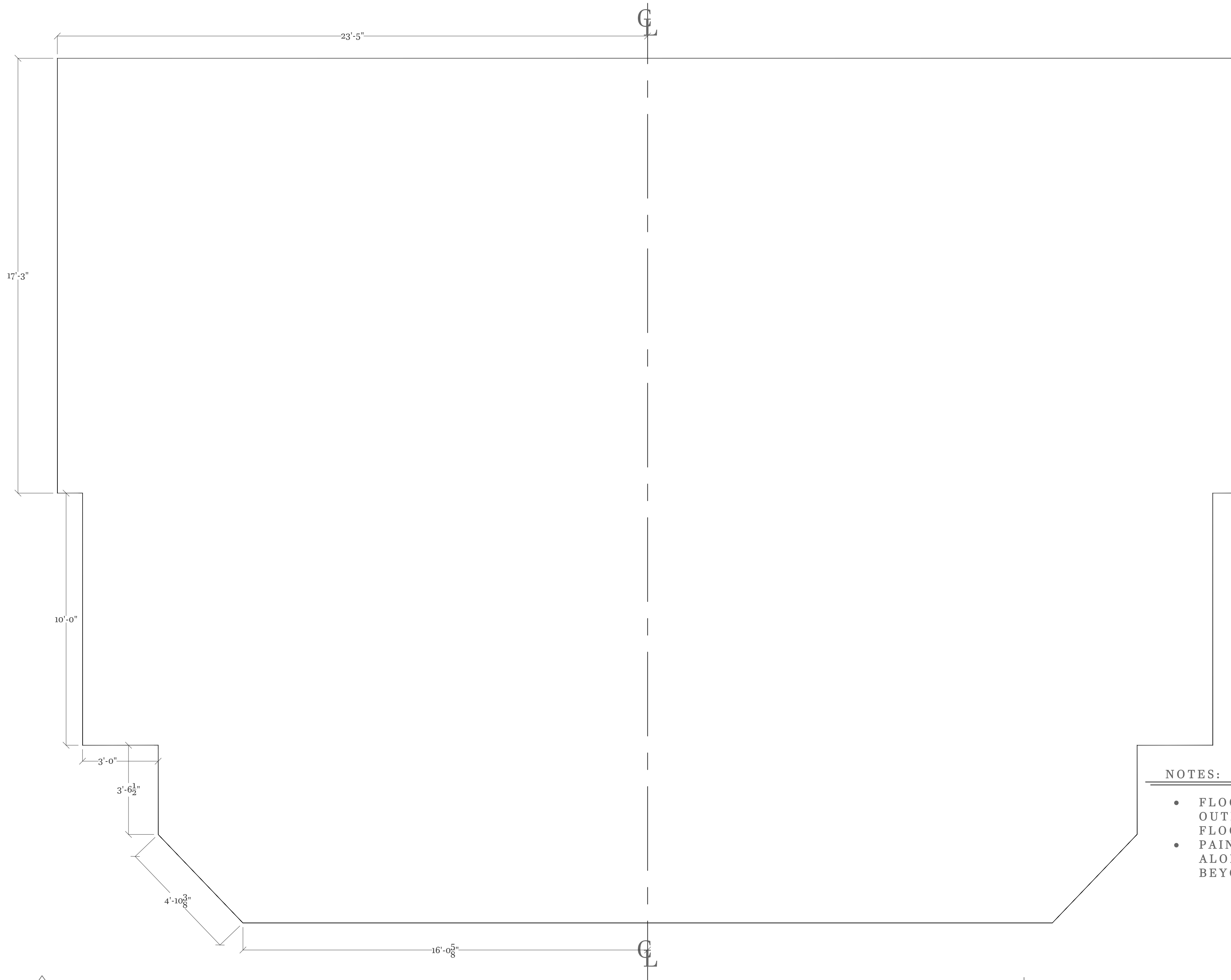

NOTES:

- FLOOR IS NOT HARD SCENERY; OUTLINE IS A GUIDE FOR THE SIZE OF FLOOR PAINT ELEVATIONS
- PAINTED FLOOR TO FADE TO BLACK ALONG OUTSIDE EDGE, WILL EXTEND BEYOND THIS LAYOUT.

1
14

FLOOR OUTLINE

FOR ESTIMATE ONLY



COMPOSED BY KIRKE MECHEM
 DIRECTED BY STEPHANIE HAVEY
 SCENERY DESIGNED BY LEO MURPHY
 AGNES DeMILLE THEATER

SCALE: 3/8" = 1'- 0"

PLATE NO.
14 OF **14**

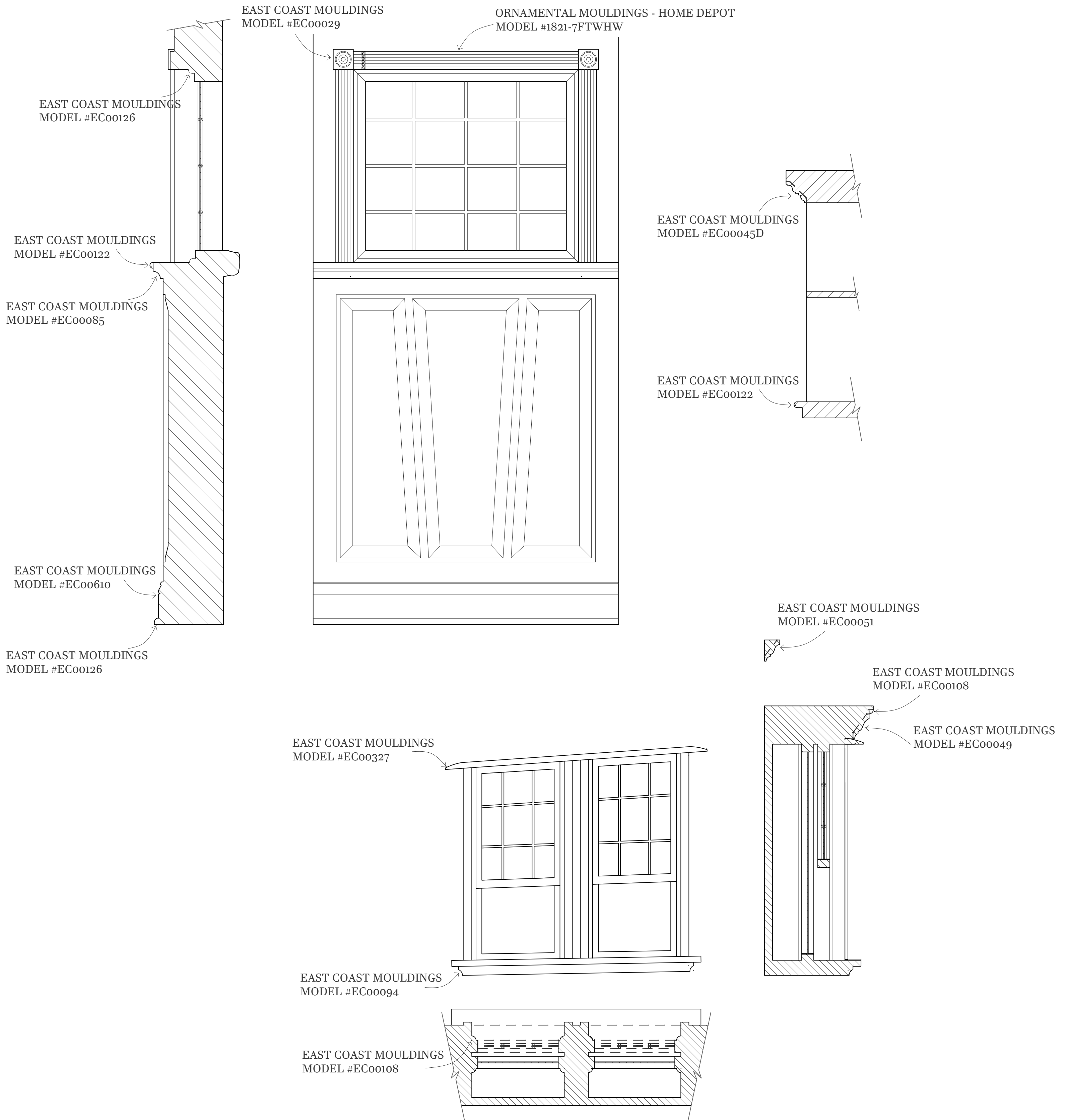

MOULDING SOURCING

AS OF 1/10/2023



COMPOSED BY KIRKE MECHEM
 DIRECTED BY STEPHANIE HAVEY
 SCENERY DESIGNED BY LEO MURPHY
 AGNES DeMILLE THEATER

SCALE: 1-1/2" = 1'- 0"

FOR ESTIMATE ONLY