

Mounting and installation manual

Sliding gate opener PULL TSA

V 2.1.002



tousek[®]
G A T E A U T O M A T I O N



General warning and safety details	3	
1. Features, general, function, technical data	4	
2. Installation	5	
Technical layout of PULL TSA, general installation notes, warning note	5	
2.1 Installation of the motor	6	
2.2 Installation of teh gear rack	7	
2.3 Dismantling.....	7	
3. Control board, layout of the control board.....	8	
Warning notes - connection works.....	9	
3.1 Clamp/terminal assignment.....	9	
3.2 Adjustments - overview, programming buttons	10	
Stucture of the menu	11	
3.3 Connections and adjustments	12	
<table border="1" style="display: inline-table; vertical-align: middle;"><tr><td>P0</td></tr></table> Radio (radio programming)	P0	12
P0		
<table border="1" style="display: inline-table; vertical-align: middle;"><tr><td>P1</td></tr></table> Mounting direction	P1	13
P1		
<table border="1" style="display: inline-table; vertical-align: middle;"><tr><td>P2</td></tr></table> Impulse button	P2	13
P2		
<i>Pedestrian button, STOP-contact</i>	14	
<table border="1" style="display: inline-table; vertical-align: middle;"><tr><td>P3</td></tr></table> Photocells	P3	15
P3		
Photocells - examples of connection	15	
<table border="1" style="display: inline-table; vertical-align: middle;"><tr><td>P4</td></tr></table> Safety edges (MSE-main , SSF- side safety edge)	P4	16
P4		
<table border="1" style="display: inline-table; vertical-align: middle;"><tr><td>P5</td></tr></table> Max. force.....	P5	16
P5		
<table border="1" style="display: inline-table; vertical-align: middle;"><tr><td>P6</td></tr></table> ARS response time.....	P6	17
P6		
<table border="1" style="display: inline-table; vertical-align: middle;"><tr><td>P7</td></tr></table> Soft stop way	P7	17
P7		
<table border="1" style="display: inline-table; vertical-align: middle;"><tr><td>P8</td></tr></table> Operating mode.....	P8	17
P8		
<table border="1" style="display: inline-table; vertical-align: middle;"><tr><td>P9</td></tr></table> Prewarning time (blinking lamp: clamp 10/11).....	P9	17
P9		
<table border="1" style="display: inline-table; vertical-align: middle;"><tr><td>PA</td></tr></table> End position.....	PA	17
PA		
<table border="1" style="display: inline-table; vertical-align: middle;"><tr><td>Pb</td></tr></table> Reset & Diagnosis	Pb	18
Pb		
4. Emergency release in case of power failure (note for the user)	19	
5. Exchange of the profil half cylinder lock	19	
6. Commisioning	20	
7. Status dispaly	21	
8. Trouble shooting guide.....	22	
9. Cable plan	24	
10. Dimensioned drawing.....	25	
11. List of the transmitter	26	
Declaration of incorporation and conformity	27	



Important warning and safety notes for minstallation and operation

- These installation and operating instructions form an integral part of the product “sliding gate operator”. They have been specifically written for professional installers trained and skilled in the trade and should be carefully read in their full length before carrying out the installation. They describe the proper installation and operation of the sliding gate operator only, not of the overall device “automatic gate”. After the installation this manual has to be handed over to the user.
- Installation, connection, adjustments, putting into operation, and servicing may only be carried out by trained professionals in full accordance with these installation- and operating instructions.
- Before carrying out works at the gate-system, the power supply has to be turned off.
- The EU Machine Directive, laws and rules concerning the prevention of accidents, and laws and standards which are in force in the EU and in the individual countries have to be strictly followed.
- The TOUSEK Ges.m.b.H. cannot be held liable for any claims resulting from disregards of the laws and standards in force during the installation and operation.
- The packaging materials (cardboard, plastic, EPS foam parts and filling material etc.) have to be properly disposed of in accordance with the applying recycling- and environmental protection laws. They may be hazardous to children and therefore have to be stored out of children’s reach.
- The product is not suitable for installation in explosion-hazardous areas.
- The product may only be used in accordance with its original purpose, for which it has been exclusively designed, and which is described in these installation and operating instructions. The TOUSEK Ges.m.b.H. rejects any liability if the product is used in any way not fully conforming to its original purpose as stated herein.
- Children have to be instructed, that the gate facility as well as the belonging parts may not be used improperly, e.g. for playing. Furthermore handheld transmitters have to be kept in safe places and other impulse emitters as buttons and switches have to be installed out of children’s reach.
- Before beginning with the installation the installer has to make sure that all mechanical components of the gate facility, like carrier profile/rail, gate frame and panels, guiding elements etc. are sufficiently supportive and resistant for the purpose of gate automation.
- All electrical installations have to be made in full conformity with the applying rules and laws (e.g. using a fault current circuit breaker, proper grounding etc.).
- An all-pole disconnecting main switch with a contact opening-gap of minimum 3 mm has to be foreseen.
- The electric motor heats up during operation. Therefore the device should only be touched after it has cooled off.
- After installation the proper function of the gate facility and the safety devices has to be checked!
- The TOUSEK Ges.m.b.H. rejects any liability for claims resulting from usage of the product in combination with components or devices which do not fully conform to the applying safety laws and rules.
- Only original spare- and replacement parts may be used for repair of the product.
- The installer has to inform the user about all aspects of the automatic operation of the complete gate facility, as well as about emergency operation. The installer further has to supply to the user all instructions relating to the safe operation of the gate facility. The installation and operating instructions also have to be handed over to the user.
- **Please notice that the warranty will not be applicable if the label with the engine number has been removed or damaged.**



Maintenance

- **Maintenance works may only be carried out by qualified personnel.**
- **The maintenance of the entire system must be carried out according to the instructions of the installer.**
- **Check the proper function of the power-operated shutdown monthly.**
- **Check the proper function of the emergency release mechanism periodically.**
- **Check if all mounting screws are securely fastened periodically.**
- **Remove dirt deposits from the operator and gear rack periodically.**

Features of PULL TSA

- Programmable via four buttons and 7-segment display or optionally via LC-Display (2 x 16 characters)
- Three selectable operating modes (impulse, automatic and dead man)
- Event memory of the last 800 cycles
- 1m partial opening for pedestrians (can also be operated via radio)
- Built in control board in separate housing
- Self-learning end positions
- Permanently self-learning force
- Safety system ARS (automatic reversal system)
- Direct connection of 8,2 kΩ safety sensing edges separated for main and side edge
- Adjustable soft stop
- Integrated radio receiver RS 868
- Up to 48 transmitters can be programmed
- Memory of the radio receiver manageable from the display
- Optional releasing system with standard half cylinder
- Gearbox unit in oil bath
- Worm gear and worm wheel made of tempered steel

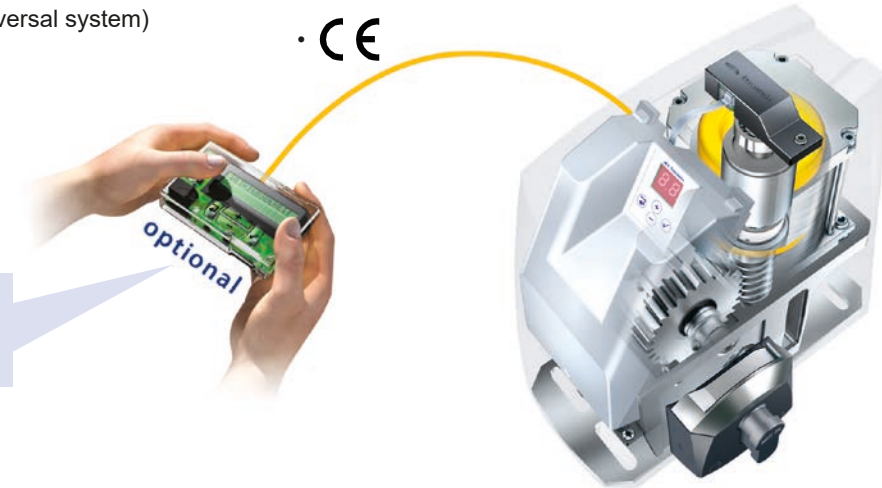

optional programming display incl. 20cm cable (art.code 12111250)

General

While developing the new operator generation Tousek PULL TSA special attention has been paid to a quick and simple installation and a troublefree operation, together with the proven quality and reliability. Accordingly, many clever details have been built into the operator - from the automatic learning of gate end positions, to the control board with removable clamps, which make it particularly user-friendly. The drive unit itself consists of an electric motor and a worm gearing, accommodated in a robust aluminium housing, and - together with the integrated microprocessor control incl. 2-ch. Radio receiver RS 868 and the safety reverse system ARS - forms a compact device with small overall dimensions.

The safety reverse system ARS senses obstacles during opening and closing of the gate and permits a continuous adjustment of the drive force. Following the Tousek tradition, all operator components have been built in a particularly robust and resistant way to guarantee the safe and reliable operation even in the most adverse weather conditions.

Additional improvements are for example: the separate control board housing, which double protects this sensible part, or the oil bath, which ensures that the motor/gearing components move in an optimal way in all temperatures with perfect lubrication and cooling effect. You can install the PULL TSA on new or already existing sliding gates in a simple and fast way.

Technical data

Schiebetorantrieb PULL TSA - Set			
Control board	integrated	Max. drive	30m
Power supply	230Va.c. 50Hz	Duty cycle in S3 mode	20 cycles/day
max. current consumption (excl. equipment)	1,3A	Ambient temperature	-20° bis +40°C
Gear wheel	Z20M4	Protection class	IP44
Max. gate weight	400kg	torque sensor	■
Speed	11m/min	Article code	61001
Torque	15Nm		
Kit accessories	1 motor PULL TSA with integrated receiver RS 868, 2-channel • 2 transmitters RS 868-4M, 4-channel • 1 photocell LS 180		
Optional equipment	Programming display incl. 20cm cable • half profile cylinder with 3 keys		

Technical layout PULL TSA

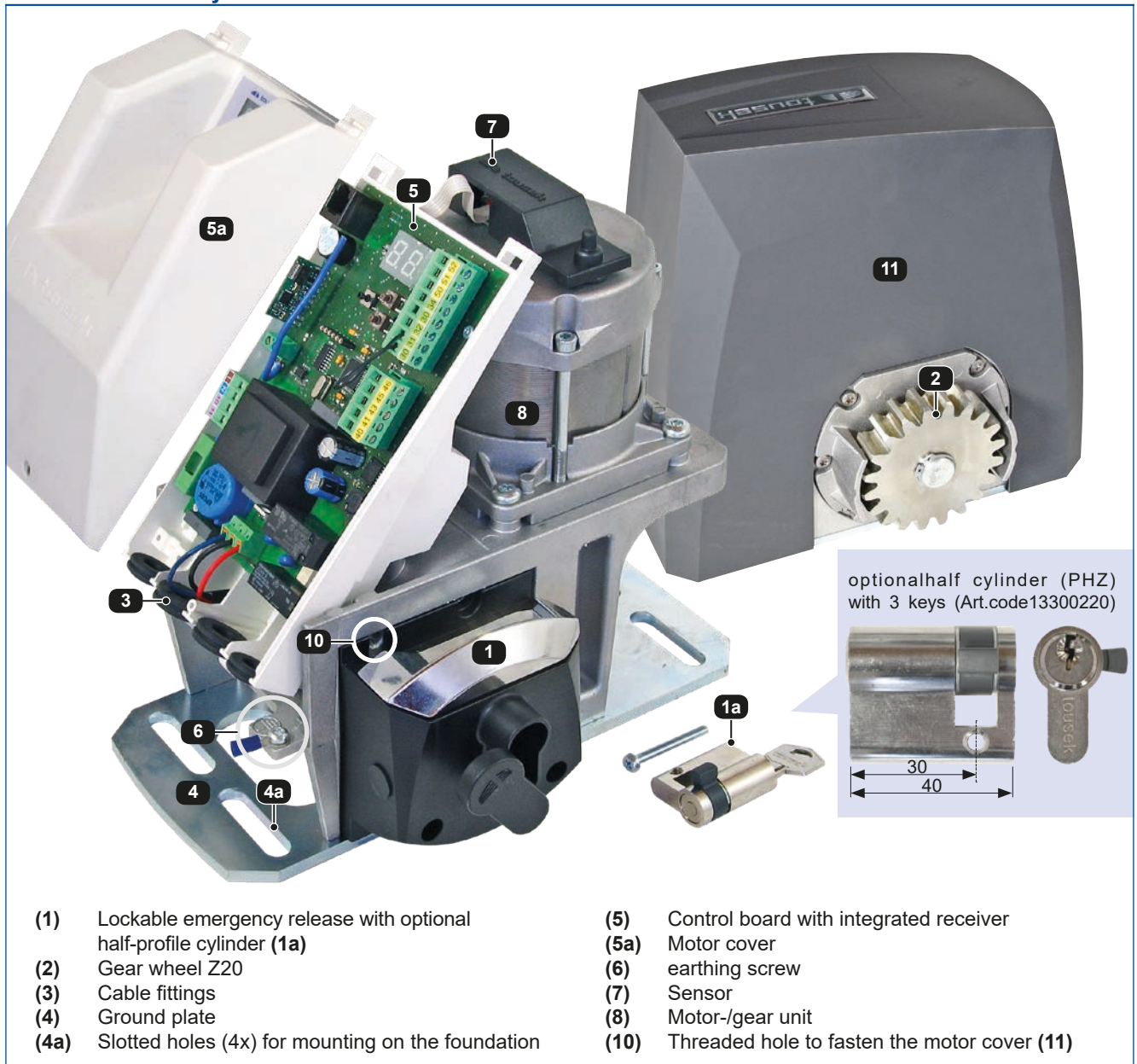

General installation notes

Before installing the Tousek PULL TSA sliding gate operator we recommend checking the following points:

- **Checking the gate structure:**
If the gate slides on floor rails, please check the bottom rollers and the upper guide rollers and make sure that there is no undue friction or jamming. In case of a cantilever gate please check if the gate can be moved out of its end-positions without undue effort.
- The gate must travel in a stable manner without any lateral movements..
- Make sure that the gate travels in a regular way without undue friction or jamming along the whole travel length.
- Make sure that there are stoppers at both ends of the track, preventing the gate from running over its travel limit.



ATTENTION !

- **Attention: Mechanical limit stops are absolutely necessary!**
- **Attention: The sliding gate operator PULL TSA has been developed and designed for the automation of horizontally travelling sliding gates. Gates on sloping tracks (i.e. gates which follow an inclined, non-horizontal, travel path) must not be automated without additional safety devices (which make sure that the gate cannot start moving on its own from any gate position).**

After installing the protection tubes (**check cable exit of operator (3)**) and having finished the concrete foundation, the motor has to be bolted through the 4 slotted holes (**4a**) to the concrete foundation. **It is particularly important that the operator is mounted parallel to the gate panel, and that the measurements given in the drawing are kept.**



NOTE concerning cable laying

- The electric cables have to be laid in insulating sleeves which are suitable for underground usage. The insulating sleeves have to be lead into the inner of the operator housing (see picture).
- 230V cables and control lines have to be laid in separate sleeves.
- Only double-insulated cables, which are suitable for underground usage (e.g. E-YY-J) may be used.
- In case that special regulations require another type of cable, cables according to these regulations have to be used.

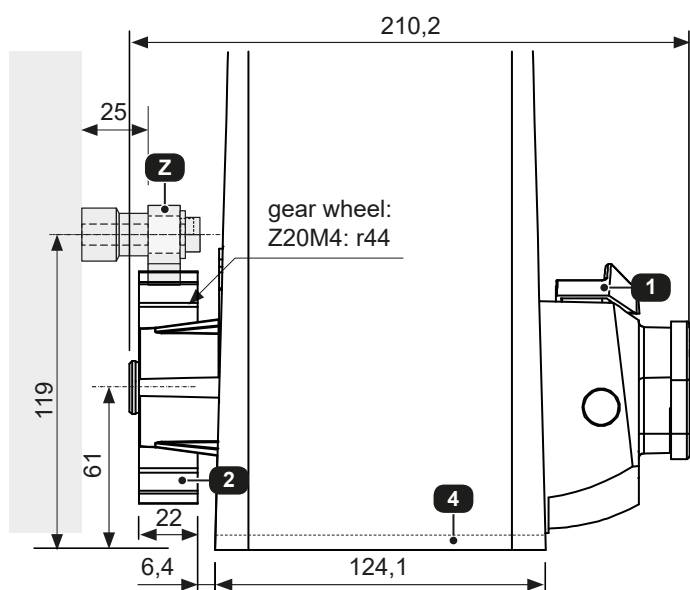

- (1) lockable emergency release with optional half-profile cylinder
- (2) gear wheel
- (3) cable exit
- (4) ground plate
- (4a) slotted holes (4x) for connection on the ground
- (Z) steel gear rack

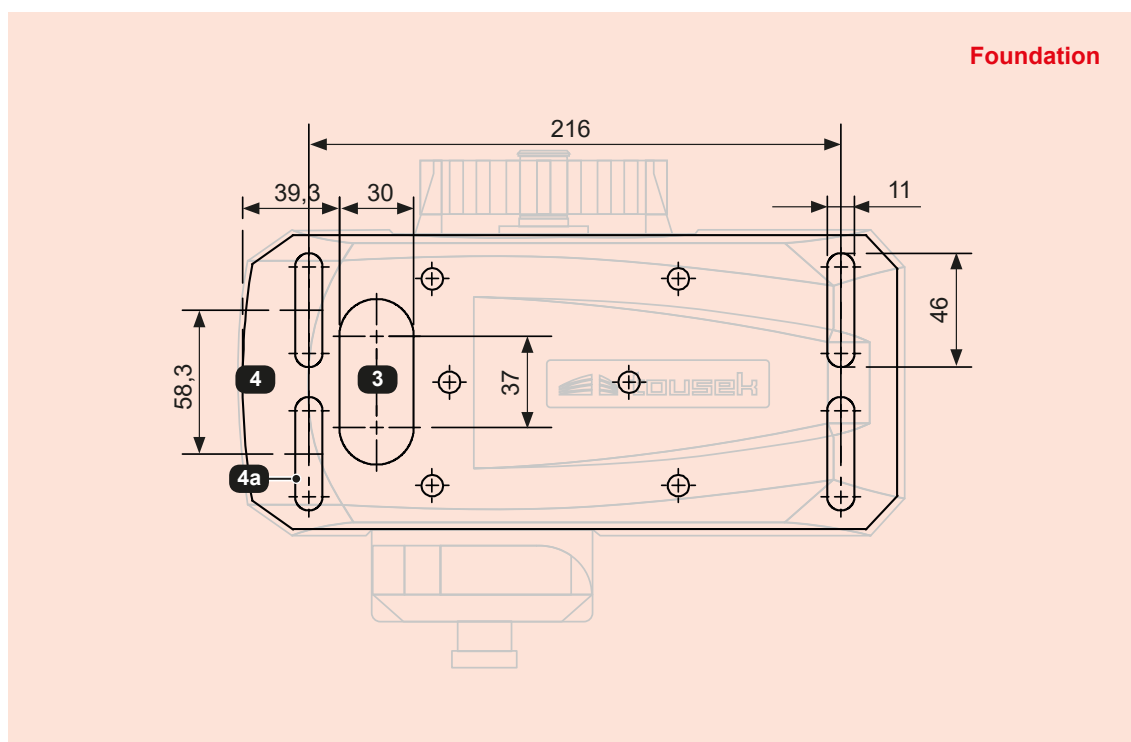

2.2 Installation of the gear rack

Installation

- Release the operator (see emergency release) and open the gate completely.
- Install the spacer tubes (D) with the help of the bolts and washers on the first meter of gear rack.
- Make sure that the bolts/screws sit in the top end of the vertical slots (L), then tighten them..
- Place the first gear rack element on the drive pinion and fix it in place with a screw clamp.
- Move the gate by hand until reaching the end of the first gear rack element, then weld the first, second, and third spacer tube to the gate.
- Proceed with the other gear rack elements in the same manner.
- **Before fixing the second meter of gear rack it is essential to place another gear rack element under the first and second gear rack elements, thereby making sure that the gearing module between the two gear rack elements will be exactly kept (see illustration).**
- After installation of the gear rack please loosen the fastening bolts slightly and rise the gear rack a little along the vertical slots, creating a **distance of approx. 1 mm between the drive pinion of the operator and the gear rack.**
- In case of gear rack elements installed without welding, please screw them to the gate frame together with the spacer tubes. Apart from that the gear rack elements have to be installed in the same manner.

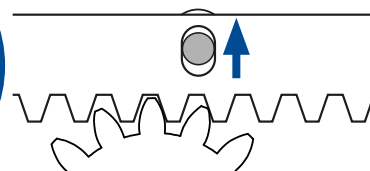
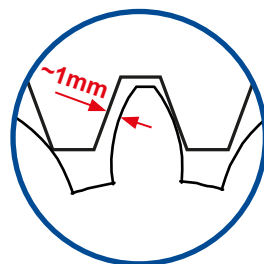
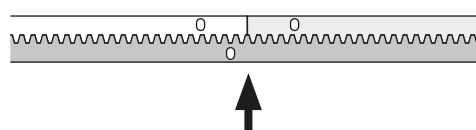
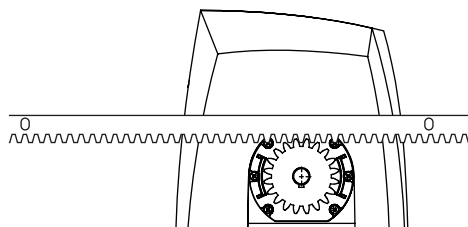
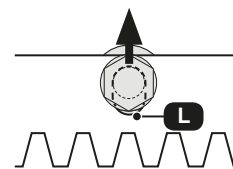
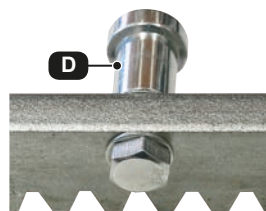

Attention

- Do not weld the individual gear rack elements together!

2.3 Dismantling

The dismantling of motor is made the other way around of mounting.



Before dismantling please plug off power supply of motor !

Overview of the control unit

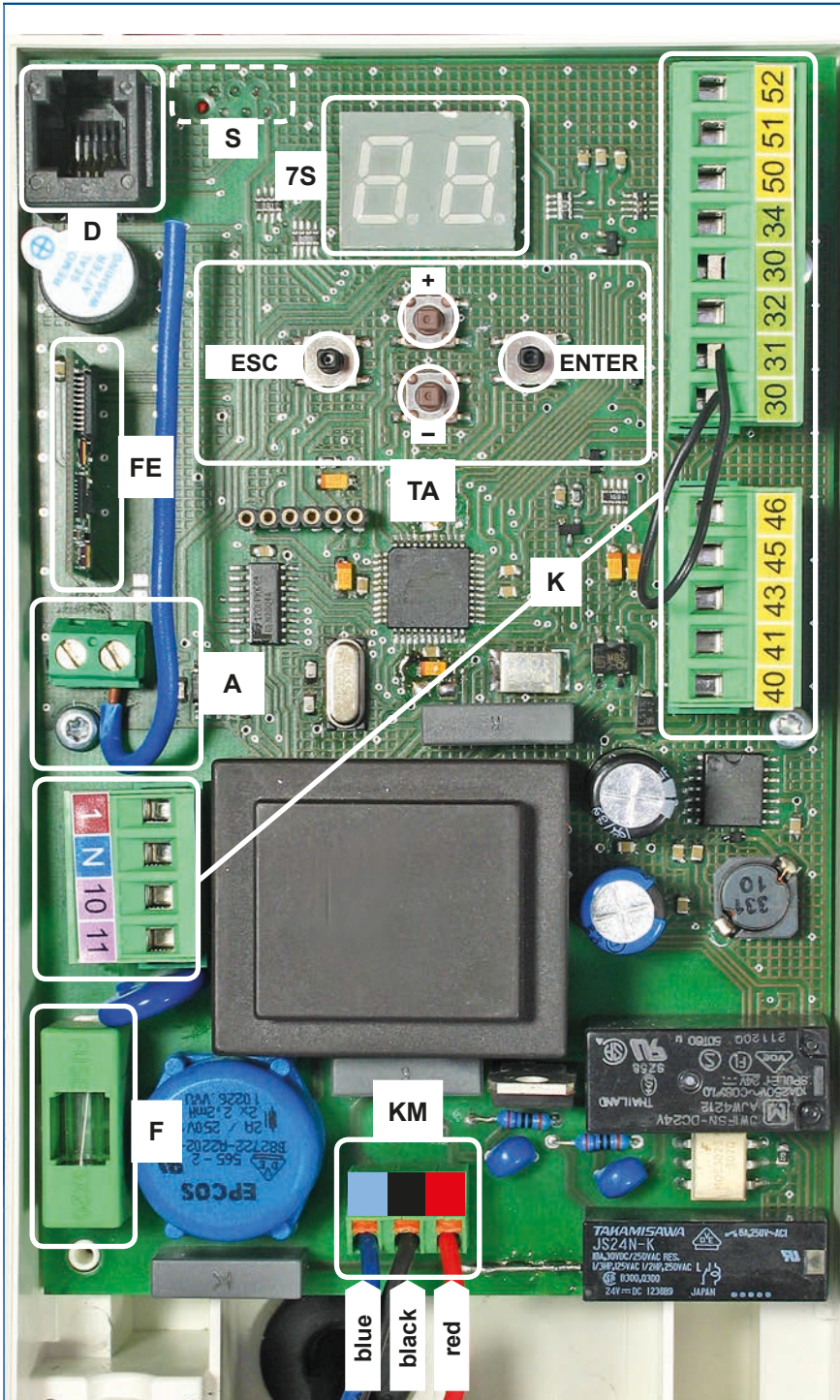

Grounding

The grounding connection is done in the operator housing by means of the designated grounding screw!



Grounding connection



Achtung

During connection, adjustment and maintenance works please take care, that the electronic circuit board won't be damaged by moisture (rain).

Elements of control board

- (K) Terminal blocks
- (KM) Motor clamps
- (FE) Integrated radio receiver
- (A) Antenna plug
- (D) Display plug
- (S) Sensor plug (on the back side)
- (7S) 7-Segment display
- (TA) Programming buttons (+, -, ESC und ENTER)
- (F) Fuse 3,15A T



Warning notes

- Before taking off the control cover, the mains switch must be turned off!
- If the control is power supplied, its inner part is under tension.
- In order to avoid electrical strokes, the safety regulations have to be kept.
- The device may only be connected by trained professionals. personal anzuschließen.
- The product is not suitable for installation in explosion-hazardous areas.
- An all-pole disconnecting mains switch with a contact opening gap of min. 3 mm has to be foreseen. The gate facility has to be secured according to the valid safety regulations!
- **IMPORTANT:** The control lines (buttons, radio, photocells, etc.) have to be laid separately from the 230V lines (supply line, motors, signal lamp).

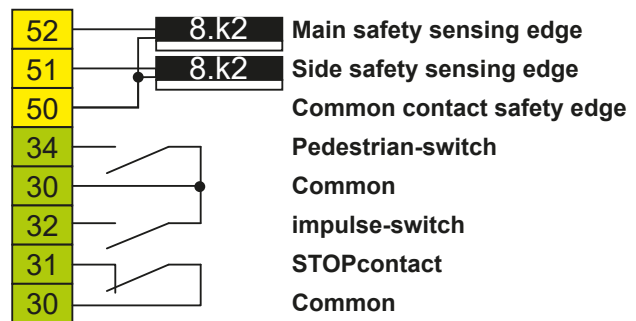

When the gate is in its CLOSED position (ready for operation) the terminal 40/41 get switched into power saving mode (i.e. no current)

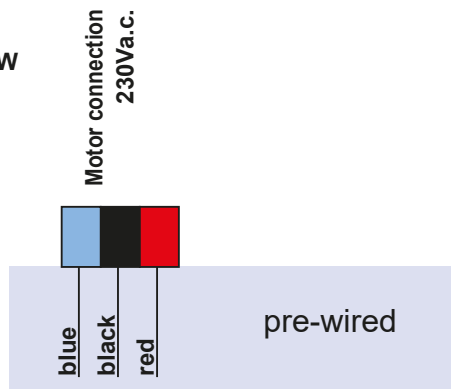
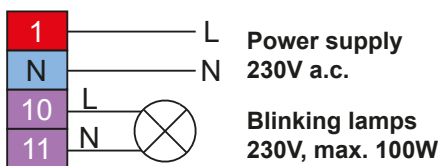
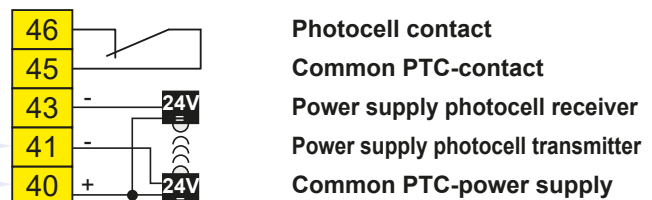

The stop input has no emergency stop function! - In order to ensure the emergency stop function, provide the supply line with an all-pole disconnecting emergency stop switch, that locks after actuation!



Alternatively to the programming of the motor via standard control panel, consisting of 4 programming buttons and a 7-segment display (7S), you can also connect the optional text display to the control unit (connector (D)). The indications are given in written form and this thereby facilitate the operation.



If the optional clear text display is connected, the programming buttons of the default panel are out of operation!

Programming buttons

Adjustments-overview

- Before programming please remove the motor cover.
- Die Anzeige (either 7Segment- (7S) or optional, external display) informs you about operating status, chosen menus and the adjustment of various parameters.
- The programming of the control is carried out with the help of four buttons (+, -, ✓ (=Enter) and ↶ (=Escape).
- Scrolling through the available menu points (up/down) or the adjustment of a parameter (value increase/decrease) is carried out with buttons + and -. **AUTO-COUNT:** when holding one of the buttons the value changes automatically.
- When pressing the ✓-button a confirmation for entering the shown menu point, resp. for accepting the shown value of a parameter is given.



- When pressing the ↶-button you return to the superior menu point. Possibly changed adjustments of a parameter are rejected with this button (the former values remain valid).
- **AUTO-EXIT:** if no button is pressed within 1 min., the menu switches automatically to the modus "ready for operation" (without saving the changed parameters).



The selectable parameters of the menu items $P0$ to Pb are marked in the table below as follows:
 ○ = selectable settings (value assignment possible) ⊙ = factory settings

Main layer		Settings									
LED display	Menu items	LED display	Settings								
P0 <i>see page 12</i>	radio	0 1 2 3	<input type="radio"/> learn impulse <input type="radio"/> learn partial opening <input type="radio"/> delete individu. <input type="radio"/> delete all <input checked="" type="radio"/> <table border="1"><tr><td>n</td><td>o</td></tr></table> (no) <input type="radio"/> <table border="1"><tr><td>y</td><td>e</td></tr></table> (yes)	n	o	y	e				
n	o										
y	e										
P1 <i>see page 13</i>	mounting direction	0 1	<input checked="" type="radio"/> <<<--- left <input type="radio"/> --->>> right								
P2 <i>see page 13</i>	impulse button	0 1 2 3 4	<input checked="" type="radio"/> OPEN/STOP/CLOSE <input type="radio"/> OPEN/CLOSE/OPEN <input type="radio"/> OPEN abort PT <input type="radio"/> OPEN extend PT <input type="radio"/> DEADMAN FUNCTION								
P3 <i>see page 15</i>	photocells	0 1 2 3	<input type="radio"/> not active <input checked="" type="radio"/> reverse during closing <input type="radio"/> Stop - after release open <input type="radio"/> during clos.stop then closing								
P4 <i>see page 16</i>	safety edges	0 1 2 3	<input type="radio"/> not active <input type="radio"/> only main edge <input type="radio"/> only side edge <input checked="" type="radio"/> MSE and SSE								
P5 <i>see page 16</i>	max. force	0-9	<input type="radio"/> 0 (weaker) ...9 (stronger) <input checked="" type="radio"/> = 7								
P6 <i>see page 17</i>	ARS-response time	0-8	<input type="radio"/> 0 (sensitive) ...8 (insensitive) <input checked="" type="radio"/> = 4								
P7 <i>see page 17</i>	soft stop way	0-9	<input type="radio"/> 0 (x 10cm) ...9 (x 10cm) soft stop way <input checked="" type="radio"/> = 5 (x10cm)								
P8 <i>see page 17</i>	operation mode	0 1 2 3 4 5 6 7 8 9	<input checked="" type="radio"/> impulse mode <input type="radio"/> aut. closing 5s <input type="radio"/> aut. closing 15s <input type="radio"/> aut. closing 30s <input type="radio"/> aut. closing 45s <input type="radio"/> aut. closing 60s <input type="radio"/> aut. closing 90s <input type="radio"/> aut. closing 120s <input type="radio"/> aut. closing 300s <input type="radio"/> aut. closing 600s								
P9 <i>see page 17</i>	prewarning time	0 1 2	<input checked="" type="radio"/> switched off <input type="radio"/> 4s only CLOSE <input type="radio"/> 4s OPEN and CLOSE								
PA <i>see page 17</i>	end position	0-9	<input type="radio"/> 0...9 <input checked="" type="radio"/> = 5								
Pb <i>see page 18</i>	reset & diagnosis	b0 b1 b2 b3 b4	<input type="radio"/> delete position <input checked="" type="radio"/> <table border="1"><tr><td>n</td><td>o</td></tr></table> (No) <input type="radio"/> <table border="1"><tr><td>y</td><td>e</td></tr></table> (YES) <input type="radio"/> factory setting <input checked="" type="radio"/> <table border="1"><tr><td>n</td><td>o</td></tr></table> (No) <input type="radio"/> <table border="1"><tr><td>y</td><td>e</td></tr></table> (YES) <input checked="" type="radio"/> status display <input checked="" type="radio"/> sensor status (0 ... 32 ... 63) <input type="radio"/> PHC test <input checked="" type="radio"/> 1 (active) <input type="radio"/> 0 (not active)	n	o	y	e	n	o	y	e
n	o										
y	e										
n	o										
y	e										



The selected setting applies to both - impulse and pedestrian - buttons

Note: some adjustments regarding function or operating logic can only be executed if the gate is closed and the display shows the status „ready for operation“.



DIGITAL

integrated control for slider PULL TSA



WARNING: Always follow the warning notes listed on page 9!

Radio

Connections and adjustments



Integrated radio receiver RS 868, 2-channel

- The integrated radio receiver is provided with a self-learning technology, i.e. the coding of the transmitter is learned into the receiver.
- Every time that a command is given, the coding gets altered by the transmitter (rolling code). Thanks to this permanent change, each code is used only once and thus an abusive use of the code by scanning is excluded.
- The receiver memory can store max. 48 transmitters. This means that all the buttons which are programmed with the function „impulse“ or „partial opening“ get stored under the same number. **IMPORTANT: Make note of the numbers shown on the display during programming procedure!**
- When the receiver memory is full by any attempt of programming a transmitter button, 3 sec. long and consecutive beeps are emitted.

Antenna

- An 8.5cm long piece of wire at the terminal strip (A) is connected to the antenna pole connection of the receiver.
- **Do not change the length of this piece of wire (loss of range)!!**
- In order to achieve longer range the antenna FK 868 is optionally available.

Antenna FK 868 (optional)

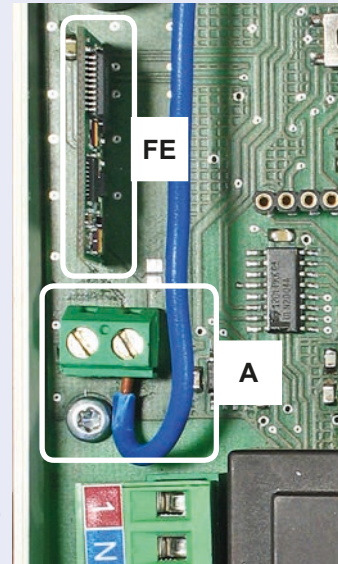

PO Radio

Buttons/ switches

- 0 ○ **learn impulse:** After confirming by pressing the ENTER button, the transmitter emits a continuous tone of approx. 10 sec. Press the transmitter buttons that have to be programmed within these 10 seconds. The successful storage process is signaled by a rapid succession of tones. **Important: Make a note of the memory position / number shown on the display (needed for deleting process).** [transmitter list page 26.](#)



SUGGESTION: with the function „programm impulse transmitter“ you can also see on the display the position of an already memorized transmitter. When you hear a continuous tone press the button P3, located on the back side of the remote control (eg with a paper clip.)

Learn impulse:

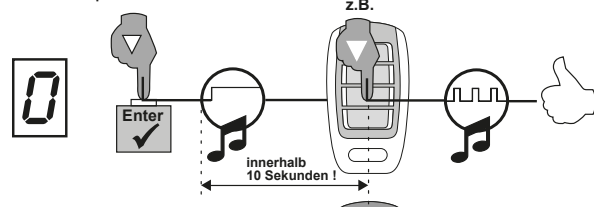

Determine memory position of an already memorized transmitter:



- 1 ○ **learn partial opening:** After confirming by pressing the ENTER button, the transmitter emits a continuous tone of approx. 10 sec. Press the transmitter buttons that have to be programmed for the partial opening within these 10 seconds. The successful storage process is signaled by a rapid succession of tones. **Important: Make a note of the memory position / number shown on the display (needed for deleting process).** [page 26.](#)

Learn partial opening:

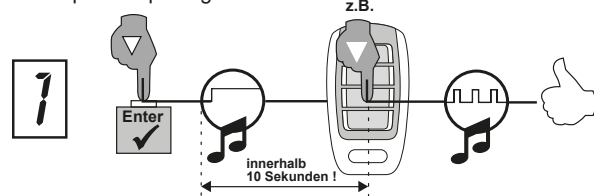

- 2 ○ **Delete individual transmitter:** After selecting with the ENTER key, the occupied memory locations are displayed. Scroll through with the buttons + - through this list until the memory location (number) displays the desired hand-held transmitter. With confirmation by the ENTER button of the remote control in question is completely extinguished, i.e. all programmed keys of the remote control.

- 3 ○ **delete all:**

n	0
y	E

 ○ **NO: do not delete the transmitters.**
○ **YES: all the programmed remote controls get deleted after confirming with ✓ Enter.**

P1

- 0 ☉ <<<--- **left**: seen from the inside, the gate opens to the left.
- 1 ○ --->>> **right**: Seen from the inside, the gate opens to the right.

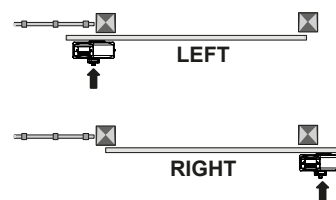

P2 Impulse button (terminals 30/32)

- 0 ☉ **OPEN/STOP/CLOSE impulse repetition** (factory settings): After a command give with the impulse switch the motor starts an open or close movement. If the impulse switch is pressed again during this movement, the motor stops. With the next command, the motor drives in the opposite direction of the last gate movement.
- 1 ○ **OPEN / CLOSE / OPEN impulse repetition**: After a command of the impulse switch the motor starts an open or close movement. If the impulse switch is pressed again during this movement, the motor reverses.

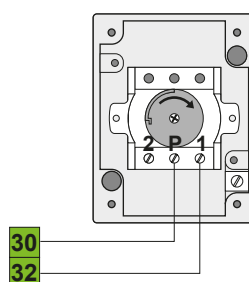

Impulse button (e.g. key switch EPZ 1-2T)

! • In this operation mode it is not possible to stop the motor with the impulse switch – it always travels until reaching an end position. (Opened or closed position).
 • for the function OPEN/CLOSE/OPEN we strongly suggest the installation of a photocell!

- 2 ○ **OPEN abort pause time**: With the impulse button you can only open the gate. It is not possible to close the gate during opening, by means of the impulse button. Only when the gate is open it is possible to terminate the pause time by giving an impulse. This causes an immediate closing movement.
- 3 ○ **OPEN extend pause time**: Only opening commands are accepted from the impulse button: ie it is not possible to close the gate via impulse button. When the gate is open the impulse button extends the pause time. The gate closes automatically after pause time.
- 4 ○ **DEAD-MAN**: The motor opens as long as the impulse switch is pressed – closing the gate with the impulse switch is not possible. As soon as the switch is released, the gate stops. **For safety reasons, once the deadman setting is selected, the radio receiver is put out of function.**



- If the impulse button is set on dead man operation, then automatically also the partial opening button will be on deadman operation. the gate will be opened by means of the impulse button and closed with the partial opening button.
- **IMPORTANT: do not carry out commissioning in dead man modus. If desired, select this function only after commissioning (see page 20).**



Pushbuttons, key switches as well as external radio receivers with potential free make contacts can be used as impulse emitters.

Pedestrian opening button (terminal 30/34)

Buttons/ /switches

- Upon actuation of the partial opening button the gate carries out **fixed partial opening of approx. 1 m**.
- **The partial opening button has automatically the same function selected for the impulse button (menu item P2).**

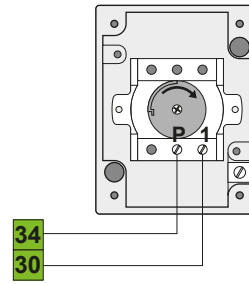

partial opening button
(e.g.. key switch EPZ 1-1T)



As impulse emitters you can use push-buttons or key switches as well as external radio receivers with potential free contacts.

STOP-contact (terminal 31/30)

Buttons / switches

- as soon as you press the stop button the gate stops in any desired position.

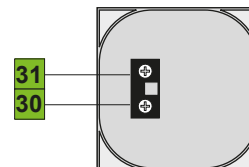

STOP button
(e.g. switch KDT-1N)



Important

As stop switch a break contact has to be used.

31
30



If no stop switch is connected, terminals 31/30 have to be wire-bridged.



The stop input has no emergency stop function! - In order to ensure the emergency stop function, provide the supply line with an all-pole disconnecting emergency stop switch, that locks after actuation!

P3 Photocell (Contact: terminals 45/46)

- 0 ○ **not active:** the safety device "photocell" is not evaluated.
- 1 ⊕ **Reverse during closing:** an interruption of the photocell during closing makes the gate reverse (open). When in automatic mode the gate closes as soon as the pause time has run out. When in impulse operation you have to give another closing command.
- 2 ○ **Stop - after release open:** an interruption of the photocell beam during opening or closing movement makes the motor stop as long as the photocell is interrupted. After releasing the photocell, the gate opens. In automatic mode the gate closes as soon as the pause time has run out. When in impulse operation you have to give another closing command.
- 3 ○ **During closing stop, then closing:** an interruption of the photocell during closing movement makes the motor stop as long as the photocell stays interrupted. After releasing the photocell, the gate closes.



Important

- If no photocell is used, please deactivate the input („not active“).



Photocells

- The control unit has a power supply connection for a 24V d.c. photocell (LS):
- supply LS-transmitter: terminals 40(+)/41(-) / supply LS-receiver: terminals 40(+)/43(-).
- Note: in „gate closed“ position the terminals 40/41 are being switched into energy saving mode - no current!
- By powered and positioned photocells the contact must be closed (NC).
- Connection of photocells contact: terminal 45/46
- Photocell self-test function: The control unit has a monitoring function for the connected photocells. A test is triggered by each impulse and will be checked if the receiver of the photocell responds to the signal from the photocell transmitter. If there is no communication between the photocell receiver and transmitter the control unit responds with an error.
- **➔ The deactivation of the self-test function is only allowed if the safety installations correspond to the category 3!**
- **Function of the photocell:** If the photocell gets triggered during the closing movement, this causes an inversion of the of gate movement. An interruption during opening movement has no effect.
- Detailed information in the corresponding photocell manual.

Photocells - connection examples

Tousek Photocell LS 180 as safety device



Important

At the control of the PULL TSA can be connected only one photocell LS 180 (included in the kit).

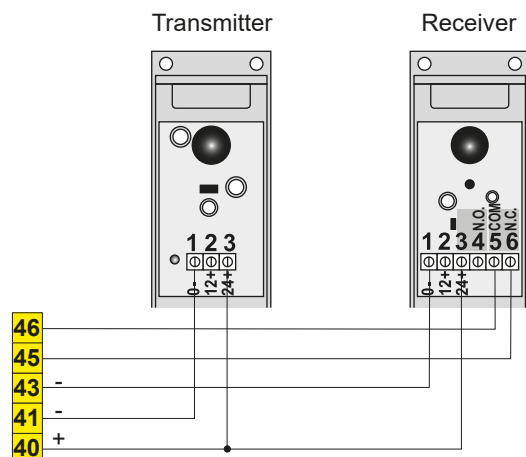

P4 Main safety edge (terminal 50/52), side safety edge (terminal 50/51)

- 0 not active : the safety devices "closing edges" are not evaluated.
- 1 only main edge: main safety edge gets evaluated.
- 2 only side edge: side safety edge gets evaluated.
- 3 MSE and SSE: main and side safety edge get evaluated.

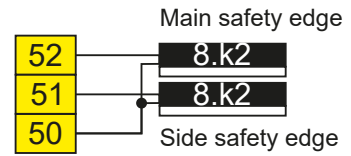

Important

- select the setting according to the carried contact strips connections!
- During the learning phase of the motor the contact edges shouldn't be triggered, since this would lead to an error message - the end stops have to be set accordingly.



Safety sensing edges (main and side edge)

• **OBSTACLE DETECTION:**

when a contact strip/safety edge is triggered/activated then a change of direction is effected for 1 second. After that the gate stops.

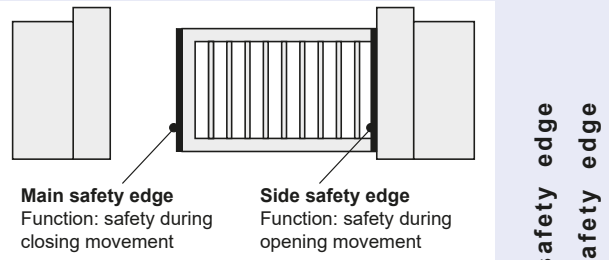

i.e.: Hence if the safety edges have to react to obstacles during the closing movement, they have to be serially connected to the terminals of the main safety edge

If the safety edges have to react to obstacles during the opening movement, they have to be serially connected to the terminals of the side safety edge

Example: W 8,2kΩ final resistance
 1 final edge
 2+3 passage edge
 S to control board

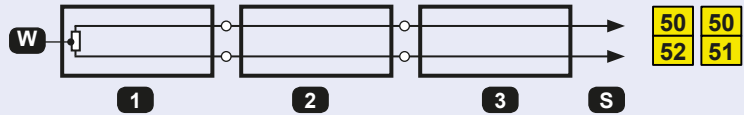

If you connect only one safety edge please use a final edge (1).

P5 factory settings: 7

- 0-9 adjustable: defines the max. permissible motor force (0 =min., 9 = max.)



Important

- The motor stops when max. set force is exceeded.
- **WARNING:** The safety regulations about the force settings must be observed!

ARS-response time

Connections and adjustments

P6 ☉ factory setting: **4**

- 0** – **8** ☉ **0–8 adjustable:** defines the response of the AR system. (0 = max. sensitivity, 8 = min. sensitivity)

Ausnahme: Befindet sich das Tor in der Teilöffnungsposition und das Tor wird über einen Befehl komplett geöffnet, so wird, nach Ablauf der Pauszeit, das Tor nicht geschlossen, sondern wieder die Gehtürposition angefahren.

Soft stop way

Connections and adjustments

P7 ☉ factory setting: **5**

- 0** – **9** ☉ **0–9 adjustable:** determines the route of the soft stops. This results approx. from the value shown in the display multiplied by 10. i.e.: the factory setting (= 5) results in a softstopp length: 5 x 10cm = 50cm.

Operation mode

Connections and adjustments

P8

- 0** ☉ **Impulse mode:** to start the closing movement of the gate, an impulse given by impulse emitter is necessary.

- 1** – **9** ☉ **automatic closing (see table):** gate closes automatically after the adjusted pause time.
Exception: If the gate is in partial open position and an impulse for complete opening arrives then the gate opens completely and after the pause time it returns to partial opening position.

Pause time		
0	☉ Impulse mode	
1	☉ aut. closing 5sec	
2	☉ aut. closing 15sec	
3	☉ aut. closing 30sec	
4	☉ aut. closing 45sec	
5	☉ aut. closing 60sec	
6	☉ aut. closing 90sec	
7	☉ aut. closing 120sec	
8	☉ aut. closing 300sec	
9	☉ aut. closing 600sec	

Prewarning time

Connections and adjustments

P9 (Blinking lamps: terminals 10/11)

- 0** ☉ **switched off**
- 1** ☉ **4s prewarning when closing**
- 2** ☉ **4s prewarning when opening and closing**



Signal lamp

- A signal lamp can be connected to the terminals 10/11 (230V, max. 100W).

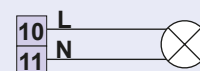

End position

Connections and adjustments

PA ☉ factory setting: **5**

- 0** – **9** ☉ **0–9 adjustable:** used to readjust the automatically detected end positions of the gate (e.g. for safety sensing edges). When the value is „0“ the motor runs to the previously learned end positions. In order to have a shorter drive distance, this value can be extended to up to 9, which means a reduction of approx 200mm for both final positions

This adjustment is ONLY adopted when the gate is CLOSED.

Pb

b0

Delete position:

NO

do not delete the end positions.

YES

the detected end positions of the motor will be deleted after confirming (✓ Enter). After giving an impulse the end positions get recalculated.



The mech. stops should be set so that ev. existing contact strips are not triggered, since this would lead to an error message.

b1

Factory setting:

NO

no resetting to factory settings.

YES

Reset to factory settings and delete of the detected end positions. The end positions are recalculated after giving an impulse.



In this manual the factory settings of the each menu item are marked with ⊙.

b2

⇒ **Status display:** status display of the following inputs on certain segments of the 7-segment display:

Segment lights up:

Input OK

Segment doesn't light up:

Input triggered or not OK

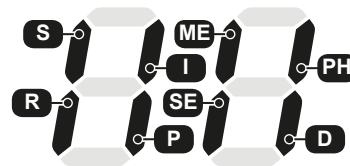

- | | | | |
|------------------------|---------------------------------|----------------------------|----------------------------|
| S Stop button | I Impulse switch | ME Main safety edge | PH Photocell |
| R Sensor active | P Partial opening button | SE Side safety edge | D Display connected |

Status shown on the optional display:

- not triggered
 triggered
 safety sensing edge interrupted
 not active

e.g.:

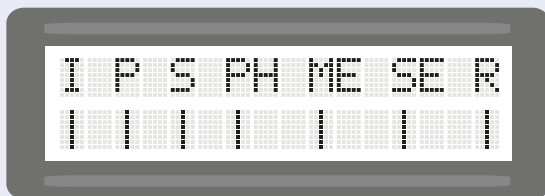

All inputs ok.



Impulse-, partial opening button not triggered.
 STOP-button and photocell triggered.
 Contact edge (main contact edge) interrupted
 Contact edge (side safety edge) shortcircuited.
 Sensor active.

b3

⇒ **Sensor status (0 ... 32 ... 63) < only display function:** Signal strength of the speed sensor is displayed on the display.

b4

PHC-Test:

1

⊙ **active:** the photocell test is performed by giving an opening impulse (button, remote) when the gate is in its closed position.

0

○ **not active:** photocell test is not performed.



Attention

- The photocell test can be suppressed by selecting „not active“.
- The deactivation of the self-test function is only permitted if the safety equipment correspond to the category 3.

In case of a power failure or other defect the motor can be disengaged from the gearmotor as follows::

- **Switch off power supply**



- Slide key-cover (A) slightly to the front and turn it away. Insert the key and turn it clockwise to its limit stop (the emergency release mechanism can be key-locked both in the engaged and in the disengaged position).
- Turn the handle 180° counter-clockwise (viewed from above). The gate can now be manually opened or closed.

Re-engaging the emergency release mechanism:

To return to normal motor operation please turn the handle back to its original position (i.e. 180° clockwise)



Wichtig

- after bringing the handle is back in normal position, slowly move the gate manually in its travel direction, until you can hear that the gearing has re-engaged!

Then lock again and remove the key.

With the next impulse the motor searches its open position (do not need to programm the end positions again).

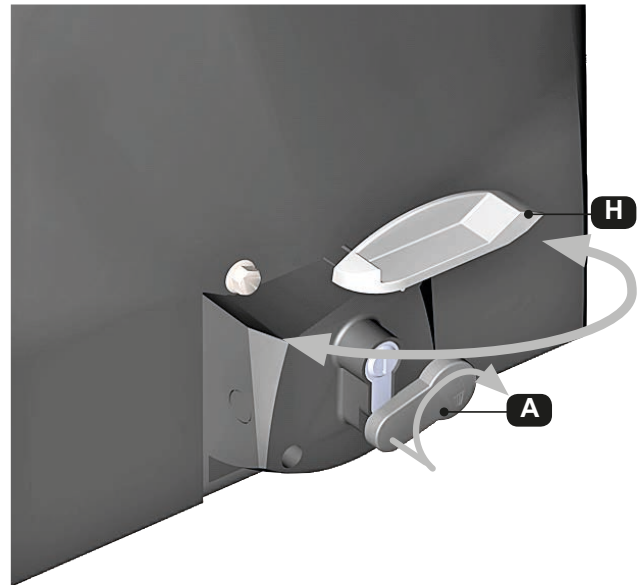

The handle in picture shows the unlocked position

5. Exchanging the halfprofile cylinder lock

- Turn the cylinder protection cap down.
- Insert the key into the cylinder that has to be installed and rotate the locking lug, so that the lock can be pushed into the actuator.
- Remove the protective cap and secure the cylinder with the screw (S). Then replace the protective cap.
- To re-insert the cylinder please carry out the above steps in the reverse order.

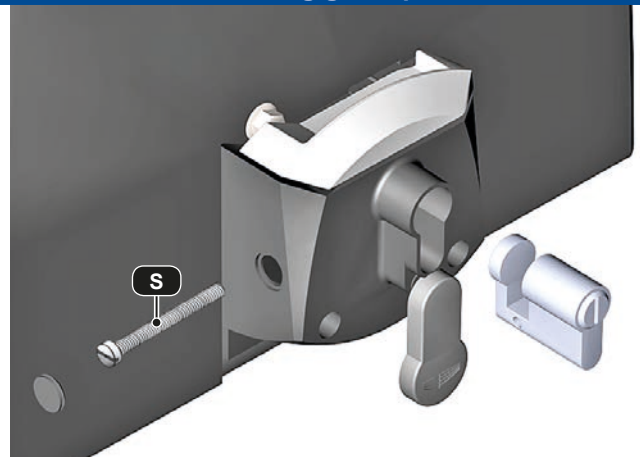



Important: preparation works

- Connect control panels, safety devices to the motor under the safety regulations in .
Attention: if no stop switch is connected then the terminals 30/31 have to be bridged.
- **The mechanical limits have to be placed so that contact edges are not triggered, as this would lead to an error message**
- Unlock emergency release of operator and set gate to half-opened position. Then lock the operator again.
- Switch on the system (assuming correct connection).
- **Important:** the commissioning has to be carried out in impulse mode (default setting) and not in deadman mode.

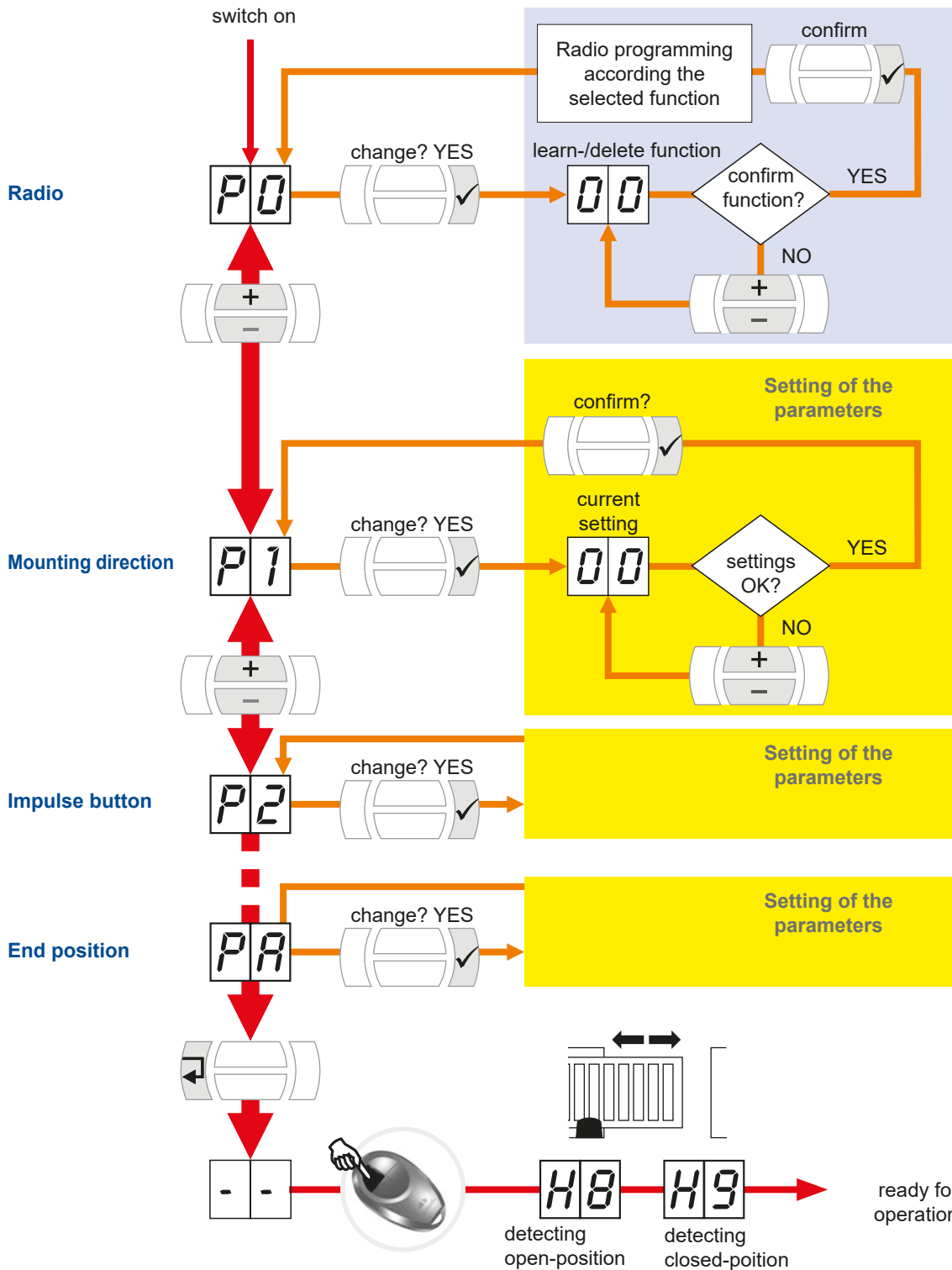

Display	Meanng
EP	detect end position open
--	ready
H0	gate closed
H1	gate opens
H2	gate stopped
H3	gate open
H4	gate partial opening
H5	gate closes
H8	detect open position
H9	detect closed position

Display / error	Meaning	Solution
F0	stop switch triggered	with the next impulse the gate moves in the same or in the opposite direction. (see <i>Stop button</i>)
	if there is no stop switch, no bridge places between terminal pair „STOP“.	place a bridge between terminals 30/31.
F1	photocell interrupted	if there is no visible interruption of the photocells, the reason could be the soiling. Check function and adjustment of the photocells.
	no photocell connected but still active in menu item P3	deactivate the photocell in P3
F2	main safety sensing edge interrupted or short circuited	check the correct functioning or remove the obstacle.
F3	side safety sensing edge interrupted or short circuited	check the correct functioning or remove the obstacle.
F4	sensor error, gate has bumped into an obstacle or is difficult to move	check the force settings, remove the obstacle / check gate smooth operation.
F5	a safety device or an impulse button has been triggered while detecting the end positions.	give another impulse
F7	receiver memory full	the integrated receiver can manage max. 48 remote controls
F8	runtime error	i.e. motor released > lock the motor
F9	sensor error (offline)	check sensor connection
No reaction when giving an impulse	no line voltage hence safety fuse broken	check line voltage as well as safety fuses
	error in the transmitter/control device/impulse button e.g. transmitter not programmed	check transmitter/control device, e.g. program transmitter and check the battery
Control relays are switching but no gate movement	motor released	lock motor gearing

9. Cable plan

Sliding gate opener PULL T8A

- 1 OPERATOR TOUSEK PULL TSA
- 2 a - outer photocell (s=transmitter, e=receiver)
- 3 Impulse button (key switch)
- 4 Stop button
- 5 Signal lamp
- 6 s - MSE main safety edge (safety when closing)
o - SSE Side safety edge (safety when opening)

- 7 power supply system TX100
When using other power supply systems (e.g. TX310) see *corresponding manual*
- 8 ext. antenna (optional) to improve the range, for integrated 2-channel receiver RS 868
- 9 fuse 12A
- 10 main switch 16 A
Note: use an all-pole separating main switch with a contact opening distance of min. 3mm.

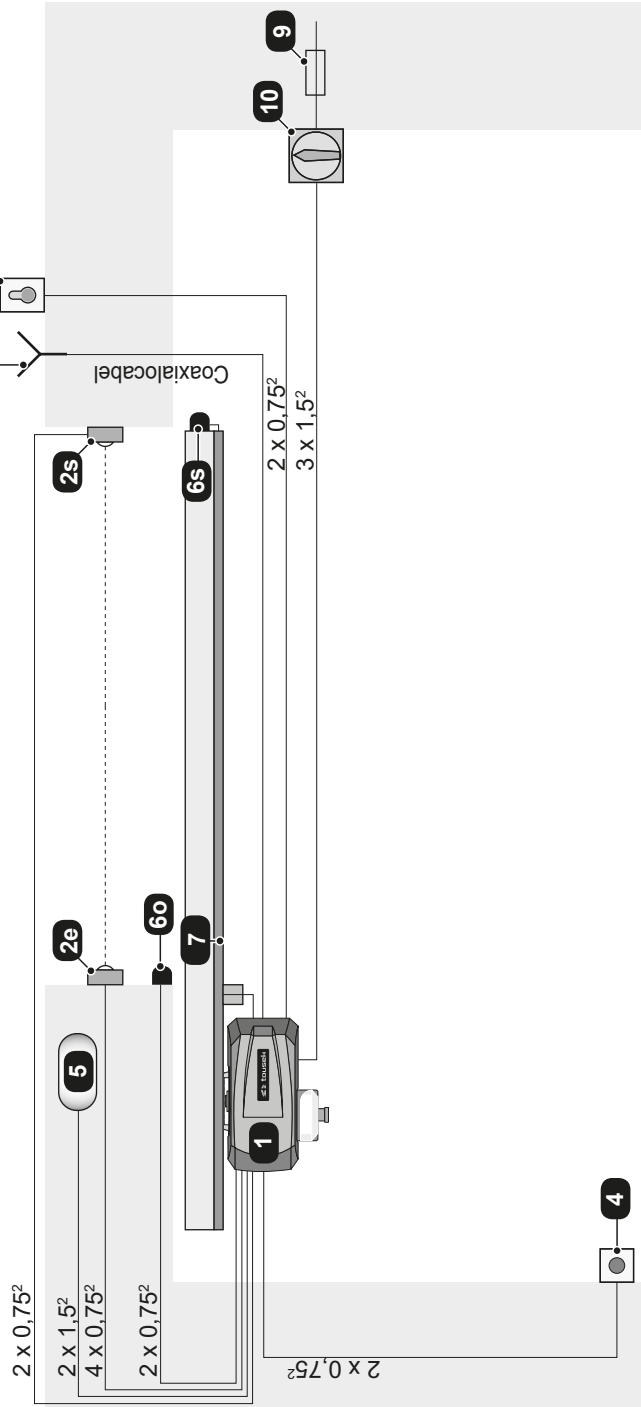

NOTE concerning cable laying

The electric cables have to be laid in insulating sleeves which are suitable for underground usage. The insulating sleeves have to be lead into the inner of the operator housing.

230 V cables and control lines have to be laid in separate sleeves.

Only double-insulated cables, which are suitable for underground usage (e.g. E-YY-J) may be used.

In case that special regulations require another type of cable, cables according to these regulations have to be used.



Warning note

Please be aware that the beside picture is only a symbolic sample illustration of a gate facility and may therefore not show all safety devices required for your specific application.

To achieve an optimum safety level at your gate facility, please make sure that all safety components and accessories which - according to the applying safety rules and laws - are required in your particular case (e.g. photocells, induction loops, sensing edges, signal lamps, traffic lights, mains- and emergency power off switches etc.) are properly installed, operated, and serviced.

In this context please follow the EU Machine Directive, accident prevention rules and laws, as well as applying EU- and national standards in force at the time of installation and operation of the gate facility.

The Tousek Ges.m.b.H. cannot be held responsible for any consequences resulting from disregard of applying standards and laws during installation or operation of the gate facility.

The 0,75mm² control lines are shown without ground lead. In order to facilitate connections we recommend using flexible wires and not using thicker wires for the control lines.

10. Dimensioned drawing

• Dimensions in mm

- (1) lockable emergency release (euro standard cylinder)
- (2) gear wheel
- (3) cable entrance
- (4) ground plate
- (4a) slotted holes (4x) for mounting on foundation

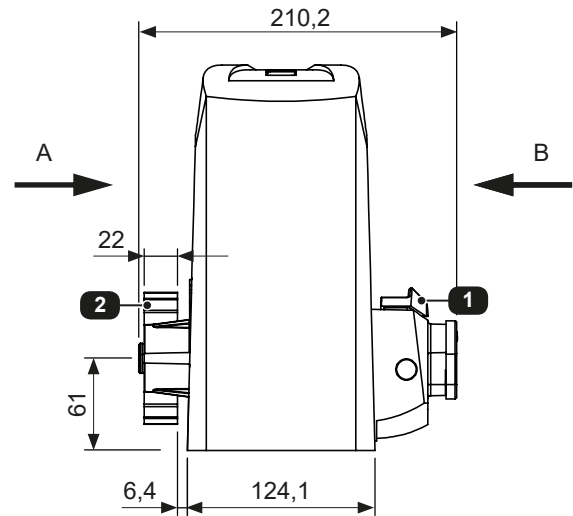

View B:

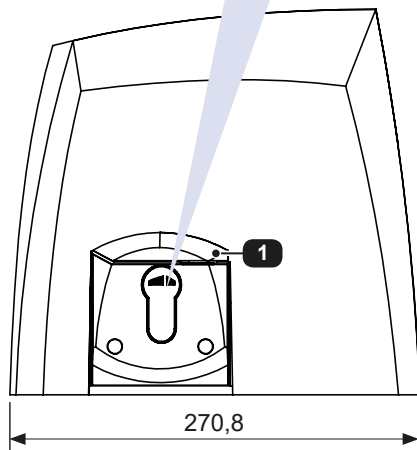

View A:

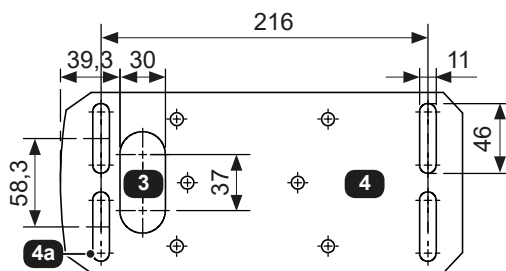
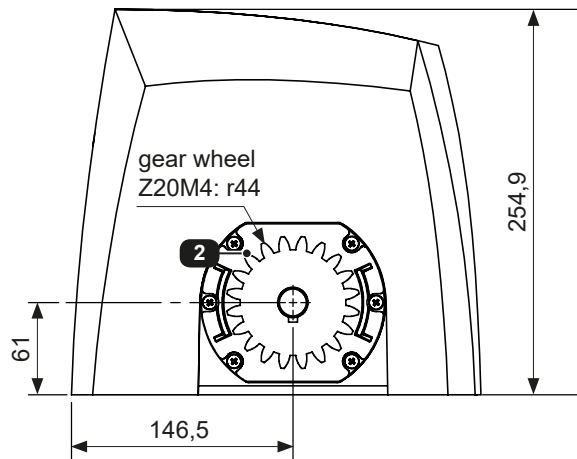

We reserve the right to change dimensions and technical specifications without prior notice.

11. List of the transmitter

Sliding gate opener PULL TSA

Memory position	Transmitter	memory position	Transmitter
0		24	
1		25	
2		26	
3		27	
4		28	
5		29	
6		30	
7		31	
8		32	
9		33	
10		34	
11		35	
12		36	
13		37	
14		38	
15		39	
16		40	
17		41	
18		42	
19		43	
20		44	
21		45	
22		46	
23		47	



Declaration of incorporation

In compliance with EC Machine Directive 2006/42/EC, Annex II B for the installation of an incomplete machine.

We hereby declare that the following product, as well as its version, put by us into circulation, complies with the essential requirements of the Machinery Directive (2006/42/EC), due to its design and type of construction.

The validity of this declaration will cease in case of any unauthorized modifications to the products.

The product:

Sliding gate opener PULL-T5, -T8, -T10, -T15, -T24, -T24speed, -T5SE, -T8 Master/Slave, -T8A, -TSA

is developed, designed and manufactured in accordance with:

Machinery Directive 2006/42/EG
Low Voltage directive 2014/35/EU
Electromagnetic compatibility 2014/30/EU

Applied and used standards and specifications:

EN ISO 13849-1, PL-,c", Cat 2
EN 60335-1 as applicable
EN 60335-2-103
EN 61000-6-3
EN 61000-6-2

Following requirements of Annex I of the EC Directive 2006/42/EC are met:

1.1.2, 1.1.3, 1.1.5, 1.2.1, 1.2.2, 1.2.3, 1.2.6, 1.3.2, 1.3.4, 1.3.7, 1.5.1, 1.5.4, 1.5.6, 1.5.8, 1.7

The relevant technical documentation is compiled in accordance with Annex VII, Part B of the EC Machinery Directive 2006/42/EC.

We undertake to submit it in electronic form and within a reasonable time to the market surveillance authorities in response to a duly substantiated request.

TOUSEK Ges.m.b.H., A1230 Wien, Zetschegasse 1, Österreich

is authorized to compile the technical documentation.

The incomplete machine cannot be put into service, until it is determined that the machine, into which the incomplete machine has to be inserted, complies with the the Machine Directive 2006/42/EC.

Eduard Tousek, CEO

Vienna, 24. 04. 2016

EC Declaration of Conformity

In compliance with EC Machine Directive 2006/42/EC, Annex II, Part 1 A.

When the described operators are connected to a gate they form a machine in the sense of the EC Machine Directive.

Relevant EU directives:

Construction Products Directive 89/106/EWG
Machinery Directive 2006/42/EG
Low Voltage directive 2014/35/EU
Electromagnetic compatibility 2014/30/EU

We hereby declare that the following product, in the version put by us into circulation, complies with the essential requirements of the Directives mentioned above. The validity of this declaration will cease in case of any unauthorized modifications to the products.

Product:

Gate description

Motor description

The incomplete machine cannot be put into service, until it is determined that the machine, into which the incomplete machine has to be inserted, complies with the the Machine Directive 2006/42/EC.

Installation company

Address, ZIP code, Place

Date/ Signature

Motor number (Type plate): _____

Other components:

tousek PRODUCTS

- sliding gate operators
- cantilever systems
- swing gate operators
- garage door operators
- folding door operators
- traffic barriers
- electronic controls
- radio remote controls
- key operated switches
- access control
- safety devices
- accessories

Tousek Ges.m.b.H. Austria
A-1230 Vienna
Zetschegasse 1
Tel. +43/ 1/ 667 36 01
Fax +43/ 1/ 667 89 23
info@tousek.at

Tousek GmbH Germany
D-83395 Freilassing
Traunsteiner Straße 12
Tel. +49/ 8654/ 77 66-0
Fax +49/ 8654/ 57 196
info@tousek.de

Tousek Benelux NV
BE-3930 Hamont - Achel
Buitenheide 2A/ 1
Tel. +32/ 11/ 91 61 60
Fax +32/ 11/ 96 87 05
info@tousek.nl

Tousek Sp. z o.o. Poland
PL 43-190 Mikołów (k/Katowic)
Gliwicka 67
Tel. +48/ 32/ 738 53 65
Fax +48/ 32/ 738 53 66
info@tousek.pl

Tousek s.r.o. Czech Republic
CZ-252 61 Jeneč u Prahy
Průmyslová 499
Tel. +420 / 777 751 730
info@tousek.cz

tousek
E_PULL-TSA_03
04. 04. 2019



tousek[®]
G A T E A U T O M A T I O N

your service partner:

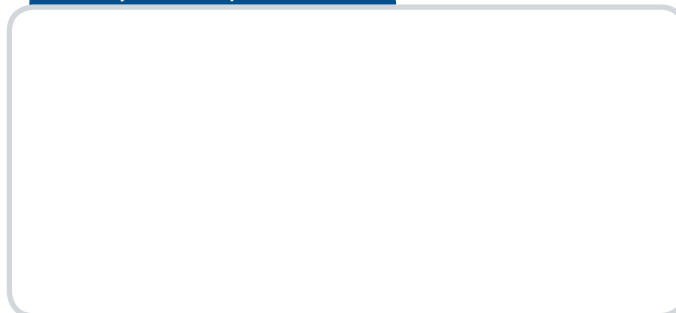

We reserve the right to change dimensions and/or technical specifications without prior notice. Claims resulting from misprints or errors cannot be accepted.

