

MILORD

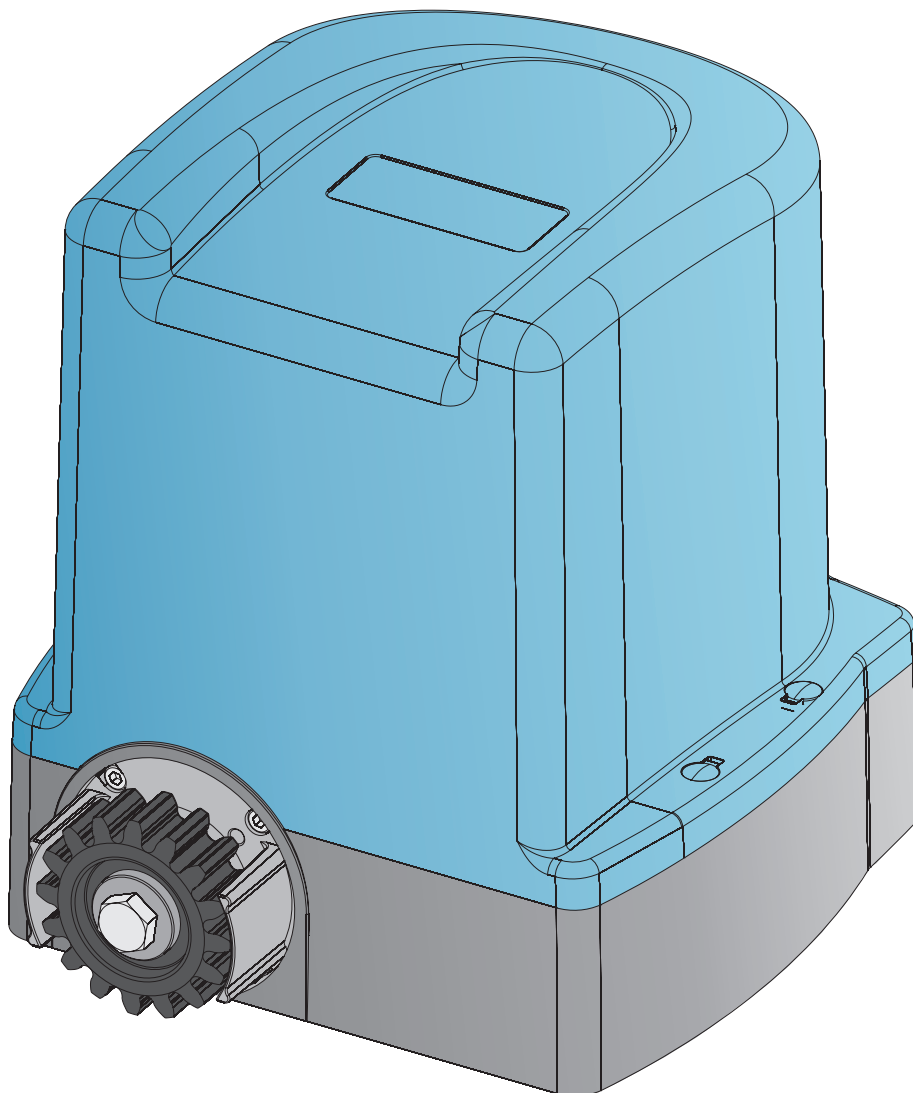

GENIUS[®]

COMPANY
WITH QUALITY SYSTEM
CERTIFIED BY DNV
= UNI EN ISO 9001/2000 =

CE

ENGLISH

IMPORTANT NOTICE FOR THE INSTALLER

GENERAL SAFETY REGULATIONS



ATTENTION! To ensure the safety of people, it is important that you read all the following instructions. Incorrect installation or incorrect use of the product could cause serious harm to people.

1. Carefully read the instructions before beginning to install the product.
2. Do not leave packing materials (plastic, polystyrene, etc.) within reach of children as such materials are potential sources of danger.
3. Store these instructions for future reference.
4. This product was designed and built strictly for the use indicated in this documentation. Any other use, not expressly indicated here, could compromise the good condition/operation of the product and/or be a source of danger.
5. GENIUS declines all liability caused by improper use or use other than that for which the automated system was intended.
6. Do not install the equipment in an explosive atmosphere: the presence of inflammable gas or fumes is a serious danger to safety.
7. The mechanical parts must conform to the provisions of Standards EN 12604 and EN 12605.
8. For non-EU countries, to obtain an adequate level of safety, the Standards mentioned above must be observed, in addition to national legal regulations.
9. GENIUS is not responsible for failure to observe Good Technique in the construction of the closing elements to be motorised, or for any deformation that may occur during use.
10. The installation must conform to Standards EN 12453 and EN 12445. The safety level of the automated system must be C+D.
11. Before attempting any job on the system, cut out electrical power and disconnect the batteries.
12. The mains power supply of the automated system must be fitted with an all-pole switch with contact opening distance of 3mm or greater. Use of a 6A thermal breaker with all-pole circuit break is recommended.
13. Make sure that a differential switch with threshold of 0.03 A is fitted upstream of the system.
14. Make sure that the earthing system is perfectly constructed, and connect metal parts of the means of the closure to it.
15. The automated system is supplied with an intrinsic anti-crushing safety device consisting of a torque control. Nevertheless, its tripping threshold must be checked as specified in the Standards indicated at point 10.
16. The safety devices (EN 12978 standard) protect any danger areas against mechanical movement Risks, such as crushing, dragging, and shearing.
17. Use of at least one indicator-light is recommended for every system, as well as a warning sign adequately secured to the frame structure, in addition to the devices mentioned at point "16".
18. GENIUS declines all liability as concerns safety and efficient operation of the automated system, if system components not produced by GENIUS are used.
19. For maintenance, strictly use original parts by GENIUS.
20. Do not in any way modify the components of the automated system.
21. The installer shall supply all information concerning manual operation of the system in case of an emergency, and shall hand over to the user the warnings handbook supplied with the product.
22. Do not allow children or adults to stay near the product while it is operating.
23. The application cannot be used by children, by people with reduced physical, mental, sensorial capacity, or by people without experience or the necessary training.
24. Keep remote controls or other pulse generators away from children, to prevent the automated system from being activated involuntarily.
25. Transit through the leaves is allowed only when the gate is fully open.
26. The User must not in any way attempt to repair or to take direct action and must solely contact qualified GENIUS personnel or GENIUS service centres.
27. Anything not expressly specified in these instructions is not permitted.

INDEX

1. DESCRIPTION AND TECHNICAL SPECIFICATIONS	page.7
2. ELECTRICAL SET-UP	page.7
3. INSTALLING THE AUTOMATED SYSTEM	page.7
3.1. PRELIMINARY CHECKS	page.7
3.2. INSTALLING THE OPERATOR	page.7
3.3. INSTALLING THE RACK	page.8
3.4. POSITIONING THE STROKE-LIMIT MAGNETS	page.9
4. START-UP	page.10
5. AUTOMATED SYSTEM TEST	page.10
6. MANUAL MODE OPERATION	page.10
7. SPECIAL APPLICATIONS	page.10
8. MAINTENANCE	page.10
9. REPAIRS	page.10

CE DECLARATION OF CONFORMITY FOR MACHINES (DIRECTIVE 98/37/EEC)

Manufacturer: GENIUS S.p.A.

Address: Via Padre Elzi, 32 - 24050 - Grassobbio- Bergamo - ITALY

Declares that: Operator mod. **MILORD 5 - MILORD 8 - MILORD 424**

- is built to be incorporate in a machine or to be assembled with other machinery to create a machine under the provisions of Directive 98/37/EC;
- conforms to the essential safety requirements of the other following EEC directives:



73/23/EEC and subsequent amendment 93/68/EEC.
89/336/EEC and subsequent amendment 92/31/EEC and 93/68/EEC

Furthermore, the manufacturer declares that the machinery must not be put into service until the machine into which it will be incorporated or of which it will become a part has been identified and its conformity to the conditions of Directive 98/37/EC has been declared.

Grassobbio, 01-06-2006

Managing Director
D. Gianantoni



Notes on reading the instruction
Read this installation manual to the full before you begin installing the product.
The symbol  indicates notes that are important for the safety of persons and for the good condition of the automated system.
The symbol  draws your attention to the notes on the characteristics and operation of the product.

MILORD AUTOMATED SYSTEM

The MILORD automated system for residential sliding gates is an electro-mechanical operator which transmits motion to the leaf through a pinion gear suitably coupled to a rack fitted on the gate.

The non-reversing system ensures mechanical locking when the motor is not operating and, therefore, installing a lock is unnecessary. A handy release facility makes it possible to move the gate in the event of a power cut or fault.

This operator has no mechanical clutch, and, therefore, requires a control unit with electronic clutch.

In the "C" versions, MILORD operators have the electronic control unit built into the operator body.

1. DESCRIPTION AND TECHNICAL SPECIFICATIONS

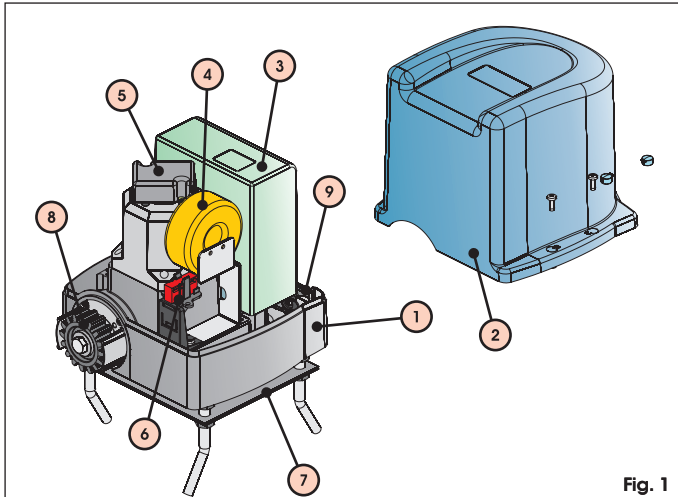

Fig. 1

1 Gearmotor	6 Magnetic sensor
2 Protective housing	7 Foundation plate
3 Control unit *	8 Pinion
4 Toroidal transformer **	9 Release device
5 Encoder **	

* Standard supply only in "C" versions
 ** For MILORD 424C model only

TECHNICAL SPECIFICATIONS OF OPERATORS

Model	MILORD 5-5C	MILORD 424-424C	MILORD 8-8C
Power supply	230V~ 50Hz	24 Vdc	230V~ 50Hz
Absorbed power	350 W	70 W	500 W
Absorption	1.5 A	3 A	2.2 A
Electric motor rpm	1400		
Thrust capacitor	10 μ F 400V	/	12.5 μ F 400V
Reduction ratio	1:25		
Pinion	Z16		
Rack	module 4		
Max torque	18 Nm	13.5 Nm	24 Nm
Max thrust	45 daN	40 daN	65 daN
Thermal protection on winding	140°C	/	140°C
Use frequency	30%	100%	40%
Operating ambient temperature	-20°C +55°C		
Operator weight	10 Kg		11Kg
Protection class	IP44		
Max gate weight	500 Kg	400 Kg	800 Kg
Gate speed	12 m/min		
Max gate length	15 m		

2. ELECTRICAL SET-UP

(standard system)

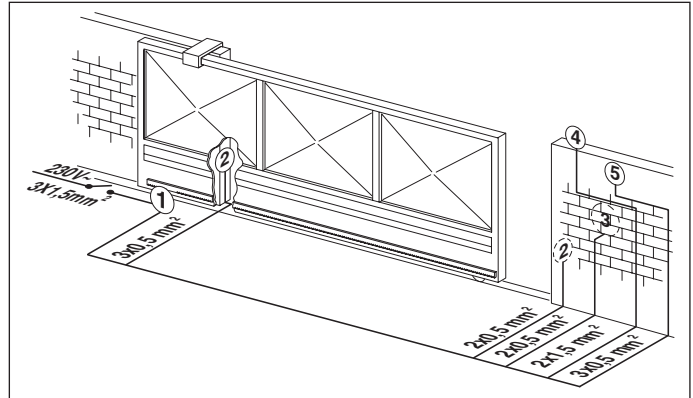

Fig. 2

1. Operator with built-in control unit (supply a suitable foundation plate)
2. Photocells
3. Key push-button
4. Flashing lamp
5. Receiver

- 1) To lay cables, use adequate rigid and/or flexible tubes.
- 2) Always separate connection cables of low voltage accessories from those operating at 230 V~. To prevent any interference whatever, use separate sheaths.

3. INSTALLING THE AUTOMATED SYSTEM

3.1. PRELIMINARY CHECKS

To ensure a correctly operating automated system, the structure of the existing gate or gate to be built must satisfy the following requirements:

- the weight of the gate must comply with the data in the technical specifications table;
- sturdy, rigid gate structure;
- smooth leaf surface (without any projections);
- smooth, uniform gate movement, without any friction during the entire travel;
- no sideward leaf swings;
- top and bottom sliding systems must be in excellent condition. It is preferable to use a ground-level guide with rounded groove to obtain reduced sliding friction.
- only two sliding wheels;
- mechanical safety stops required to prevent the danger of gate derailment; these stops must be firmly secured to the ground or to the ground-level guide at about 40 mm beyond the travel limit position.
- no mechanical closing locks.

We advise you to carry out the metalwork jobs before installing the automated system.

The condition of the structure directly influences the reliability and safety of the automated system.

3.2. INSTALLING THE OPERATOR

1. Assemble the foundation plate as in Fig.3.
2. Dig a cavity for the foundation plate as shown in Fig. 4. The foundation plate must be located as shown in Fig. 5 (right closing) or Fig.6 (left closing) to ensure correct meshing between rack and pinion.

We advise you to place the plate on a cement base about 50 cm off the ground (fig.7).

3. Lay the flexible pipes for routing the connection cables between gearmotor, accessories and electrical power supply. The flexible pipes must protrude by about 3 cm from the hole on the plate.

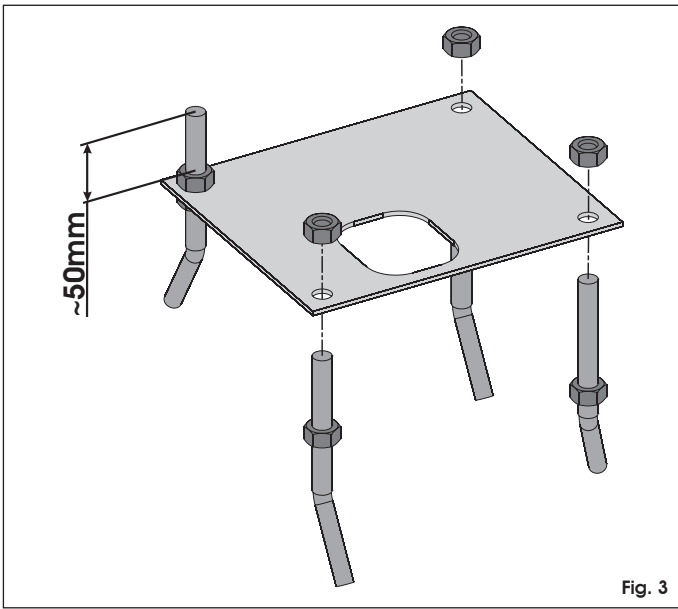

Fig. 3

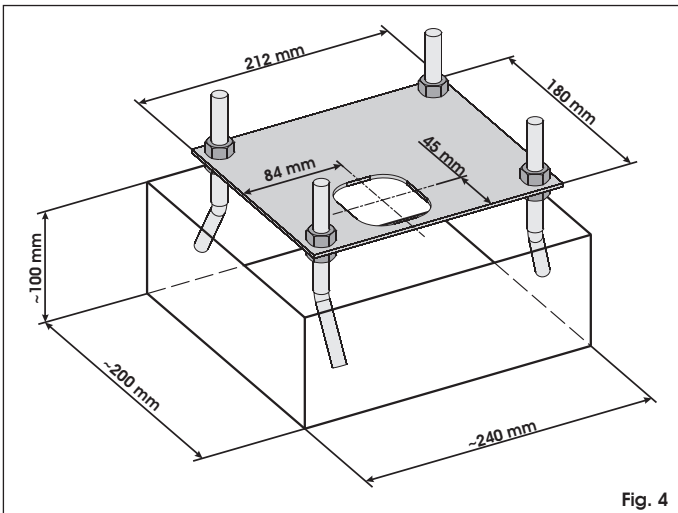

Fig. 4

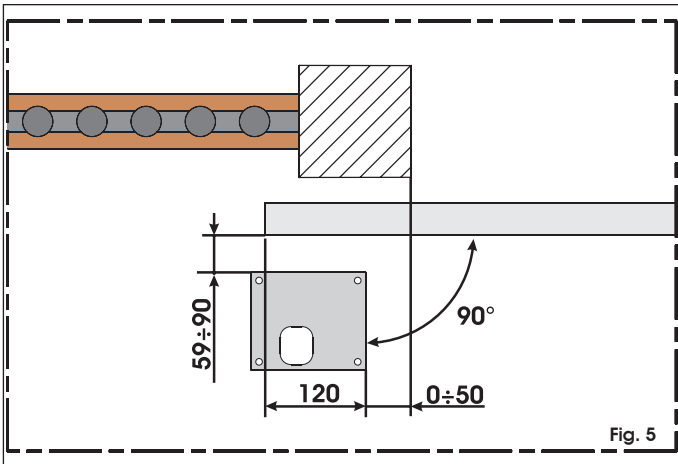

Fig. 5

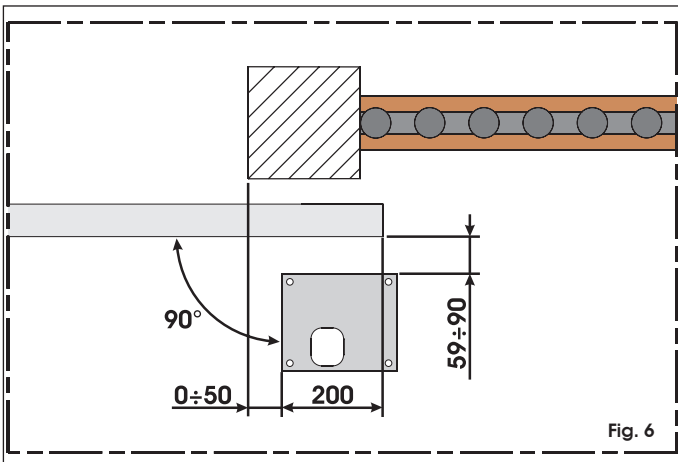

Fig. 6

4. Wall in the plate perfectly levelled.
5. Wait for the cement to set in the cavity.
6. Lay the electrical cables for connection to the accessories and the electrical power supply (paragraph 2). To facilitate making the electrical connections on the control unit, make the electric cables protrude by about 20 cm from the hole on the foundation plate.
7. Secure the operator on the foundation plate, using the supplied screws and washers as shown in Fig. 8. The operator's position is shown in Fig. 7. When positioning the operator, route the electrical cables through the hole on the base of the gearmotor body.
8. Route the connecting electrical cables through the hole on the base of the unit's support, using the supplied cable gripper.
9. Make the electrical connections to the electronic control unit according to the instructions for the unit.



1) Connect the earth cable of the system.

2) The operator is supplied for installation with the gate closing on the right of the operator (looking from the inside) (fig. 5). If you require left-hand closure, change over the connection of the cables connected to the terminals of the motor.

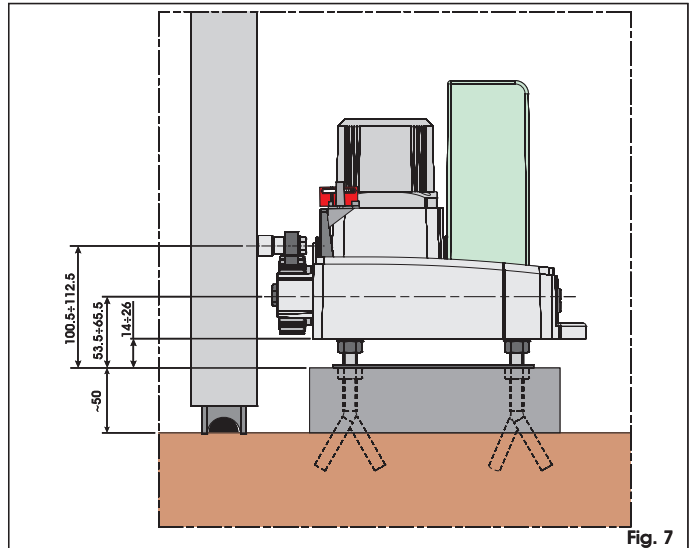

Fig. 7

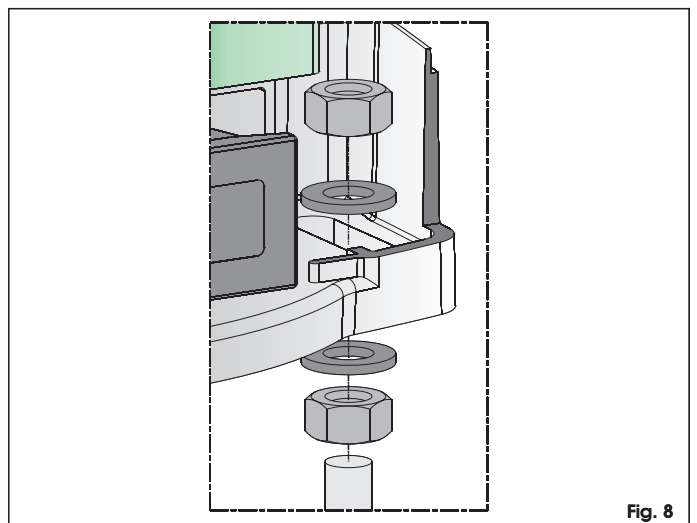

Fig. 8

The dimensions in the figures are in mm.

3.3. INSTALLING THE RACK

1. Prepare the rack (supplied on request), with the supplied Hex-head 8 x 25 screws, and spacers to be welded, as shown in Fig. 9. To avoid having to weld on the gate, galvanised through-spacers and Hex-head 8 x 50 securing screws are available.



We advise you to tighten the securing screws of the rack on the top end of the slot. This position will enable you to raise the rack when the gate tends to lower through time.

2. Release the operator (see paragraph 6).

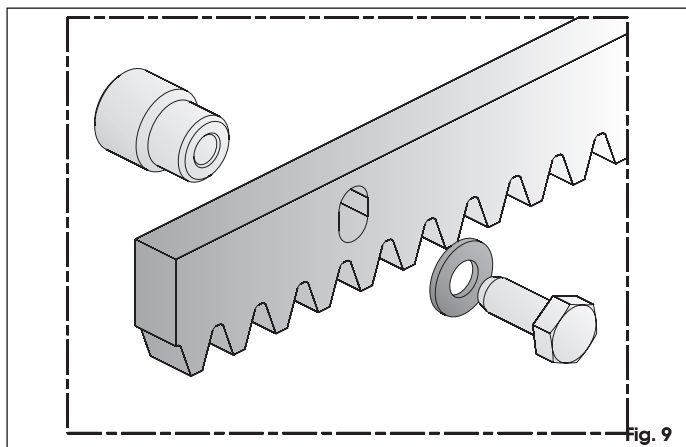

Fig. 9

3. Manually move the leaf to its open position.
4. Lay the first element of the rack on the pinion, on the first spacer (fig. 10).
5. Secure the rack element to the leaf with a clamp (fig. 10).

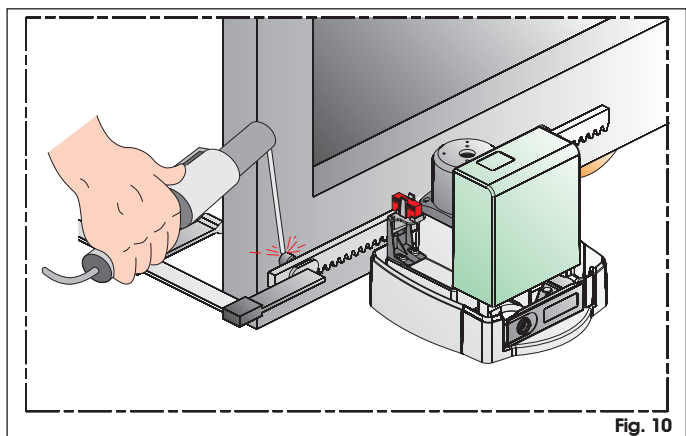

Fig. 10

6. Manually slide the leaf toward the closing point until you reach the rack's third spacer, and fix it with a weld spot.
7. Definitively weld the three spacers on the gate. Procedure for correctly fixing the other rack elements required to reach the closing position:
8. Bring near another rack element to the last fixed element, using a piece of rack to synchronise the teeth with the two elements (fig. 11).
9. Manually slide the leaf toward the closing point until you reach the pinion with the third spacer of the element to be secured (fig. 11).

⚠ Make sure that all the rack elements work on the centre of the pinion's teeth. Otherwise, adapt the gearmotor's position.

10. Weld the element's three spacers (fig. 10).

☞ a) Do not, on any account, weld the rack elements either to the spacers or to each other.

b) Do not, on any account, use grease or other lubricants between rack and pinion.

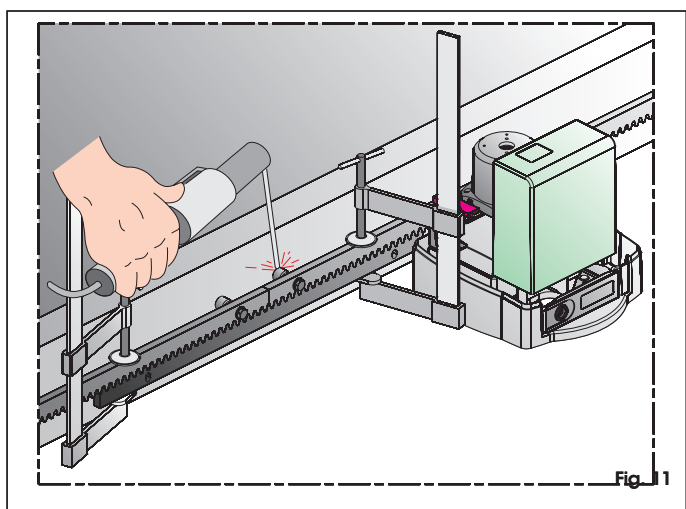

Fig. 11

11. To obtain correct play between rack and pinion, lower the gearmotor by 1.5 mm, using the nuts supporting the foundation plate. When you have finished adjusting, correctly tighten the operator securing nuts.

⚠ If the gate was recently built, check this play (fig.12) a few months after installation.

12. Manually check if the gate is free to open completely and if leaf movement is good and friction-free.

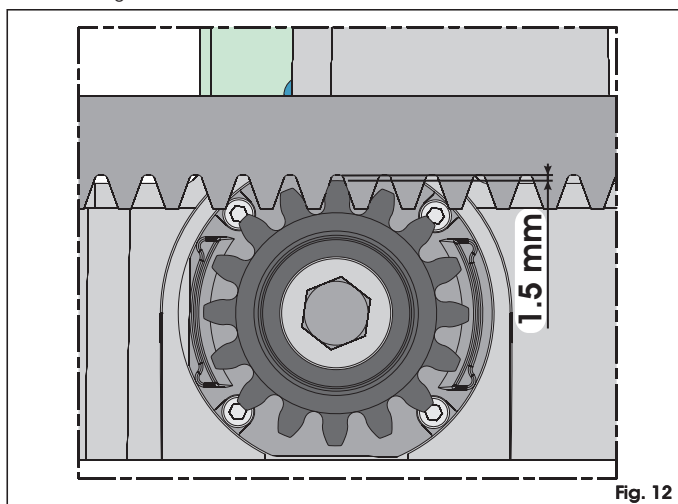

Fig. 12

3.4. POSITIONING THE STROKE-LIMIT MAGNETS

The operator has a magnetic limit-switch, which commands gate motion to stop when the magnet, which is secured to the upper part of the rack, activates the sensor. The magnets supplied with the operator are specifically polarised and activate only one of the sensor's contacts: the closing or opening contact. The magnet activating the open gate contact bears an open padlock symbol, and, vice versa, the magnet activating the closed gate contact bears the closed padlock symbol (see Fig. 13).

Procedure for a correct positioning of the two stroke-limit magnets:

1. Assemble the two magnets as shown in figure 13.

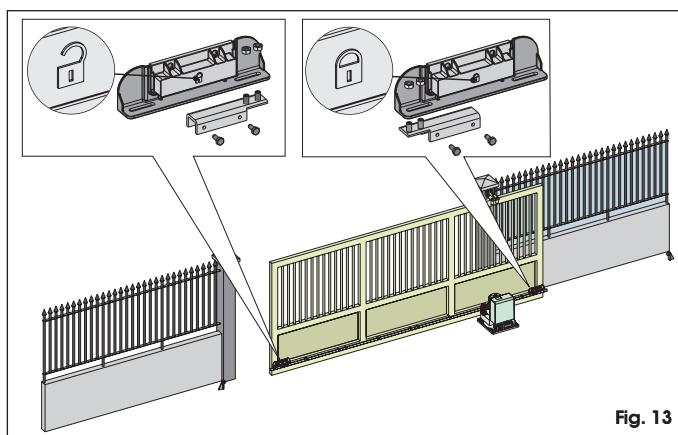

Fig. 13

2. Set the operator to manual mode operation - see chapter 6 - and power up the system.
3. Manually take the gate to opening position, leaving about 40 mm from the opening mechanical stop.
4. Allow the magnet, with the padlock open, to slide on the rack in opening direction - see figure 14. As soon as the LED on the board, referring to the opening limit-switch, goes OFF, take the magnet forward by another 10 mm and fasten it provisionally with the appropriate screws.
5. Repeat the operations from point 3 for the closing magnet.
6. Re-lock the system (see paragraph 6).

⚠ before sending a pulse, make sure that the gate cannot be moved manually.

7. Command a complete gate cycle to check if the limit-switches are operating correctly.

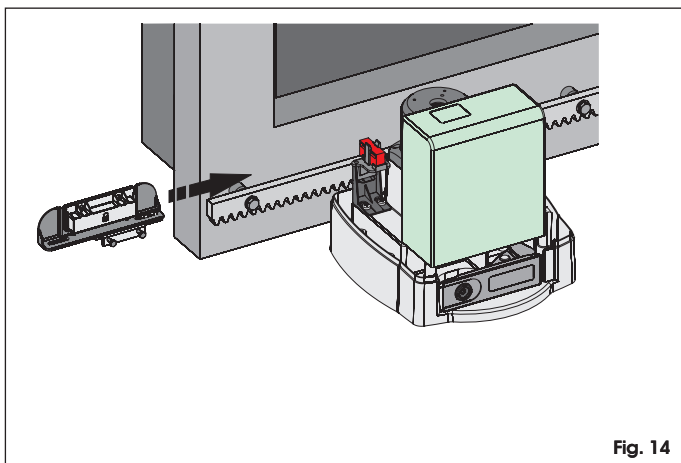

Fig. 14

⚠ - To avoid damaging the operator and/or interrupting operation of the automated system, leave a distance of about 40 mm from the safety mechanical stops.

- Make sure that at the end of both the opening and closing manoeuvre, the relevant contact stays active (LED OFF).

8. Change the position of the magnets as necessary and secure them definitively.

4. START-UP

1. Program the control unit according to your needs, as per relevant instructions.
2. Power up the system and check the condition of the LEDs according to the table in the control unit instructions.
3. When you have run the automated system test (par.5), secure the protective housing on the operator, using the supplied screws as shown in fig. 15.

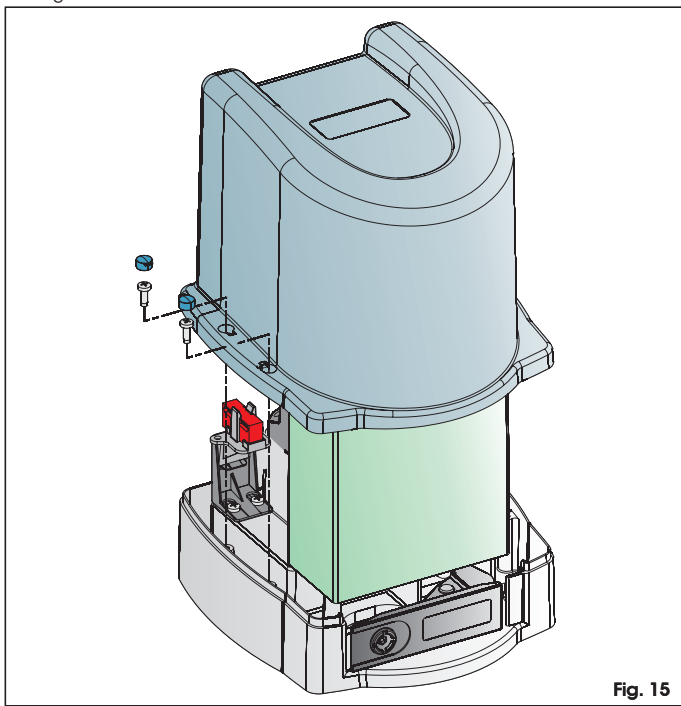

Fig. 15

5. AUTOMATED SYSTEM TEST

Check operating efficiency of the automated system and all accessories connected to it.
Hand the customer the "User's Guide" page and explain how the automated system operates correctly and how it should be used.

6. MANUAL MODE OPERATION

If the gate has to be moved manually due to a power cut or fault of the automated system, use the release device as follows:

1. Using a coin, turn the lock clockwise until it stops (Fig. 16 ref. ①)
2. Pull the lever as shown in fig. 16 ref. ②.
3. Open and close the gate manually.

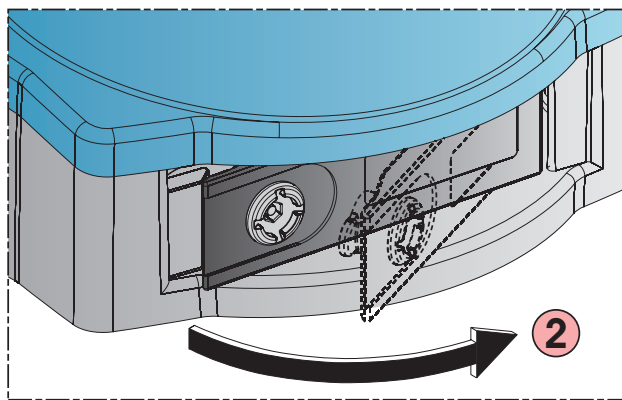
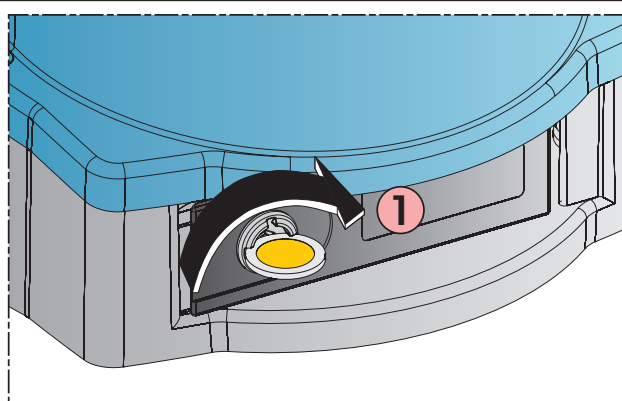

Fig. 16

Procedure for restoring normal operation:

1. Cut power to the system.
2. Position the gate at about halfway of opening travel.
3. Take the release lever back into its position;
4. Using a coin, turn the lock anti-clockwise until it stops;
5. Restore power to the system.

👉 when power is restored, command another complete opening cycle.

⚠ before sending a pulse, make sure that the gate cannot be moved manually.

7. SPECIAL APPLICATIONS

Applications other than those in this manual are EXPRESSLY PROHIBITED.

8. MAINTENANCE

To ensure correct long-term operation and a constant level of safety, we advise you to generally check the system every 6 months. In the "User's Guide" booklet, there is a form for recording jobs.

9. REPAIRS

The User must not in any way attempt to repair or to take direct action and must solely contact qualified GENIUS personnel or GENIUS service centres.

MILORD

Instructions for use

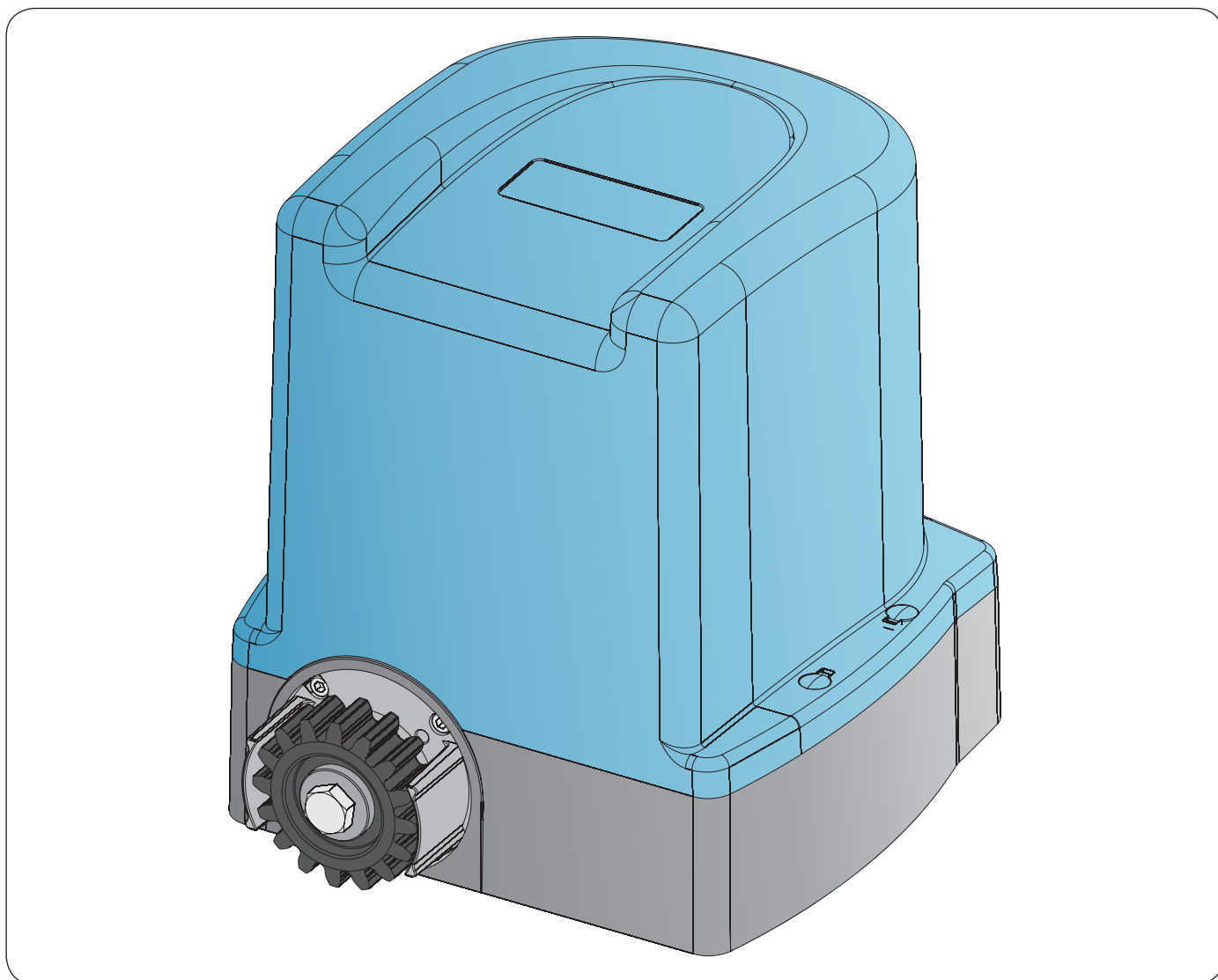

GENIUS[®]

COMPANY
WITH QUALITY SYSTEM
CERTIFIED BY DNV
= UNI EN ISO 9001/2000 =

CE

⚠ Read the instructions carefully before using the product and store them for future use

GENERAL SAFETY REGULATIONS

If correctly installed and used, the **MILORD** automated system will ensure a high degree of safety. Some simple rules on behaviour can prevent accidental trouble:

- Do not stand near the automated system, and do not allow children, persons or things to do so, especially when it is operating.
- Keep radio-controls, or any other pulse generators that could involuntarily activate the automated system, well away from children.
- Do not allow children to play with the automated system.
- Do not willingly obstruct gate movement.
- Prevent any branches or shrubs from interfering with gate movement.
- Keep the indicator-lights efficient and easy to see.
- Do not attempt to activate the gate by hand unless you have released it.
- In the event of malfunctions, release the gate to allow access and wait for qualified technical personnel to do the necessary work.
- When you have set manual operation mode, cut power to the system before restoring normal operation.
- Do not in any way modify the components of the automated system.
- Do not attempt any kind of repair of direct action whatever and contact qualified personnel only.
- At least every six months: arrange a check by qualified personnel of the automated system, safety devices and earth connection.

DESCRIPTION

The **MILORD** automated system is ideal for controlling vehicle access areas in residential ambients.

MILORD for sliding gates is an electro-mechanical operator which transmits motion to the leaf via a rack and pinion.

For details on sliding gate behaviour in different function logics, consult the installation Technician.

Automated systems include safety devices (photocells) that prevent the gate from closing when there is an obstacle in the area they protect.

The system ensures mechanical locking when the motor is not operating and, therefore, installing a lock is unnecessary. Manual opening is, therefore, only possible by using the release system.

The gearmotor has an adjustable electronic clutch enabling safe use of the automated system.

The control unit is built into the gearmotor.

A handy manual release facility makes it possible to move the gate in the event of a power cut or fault.

The warning-light indicates that the gate is currently moving.

MANUAL MODE OPERATION

If the gate has to be moved manually due to a power cut or fault of the automated system, use the release device as follows:

1. Cut power to the system;
2. Using a coin, turn the lock clockwise until it stops (Fig. 1 ref. ①);
3. Pull the lever as shown in Fig. 1 ref. ②
4. Open or close the gate manually.

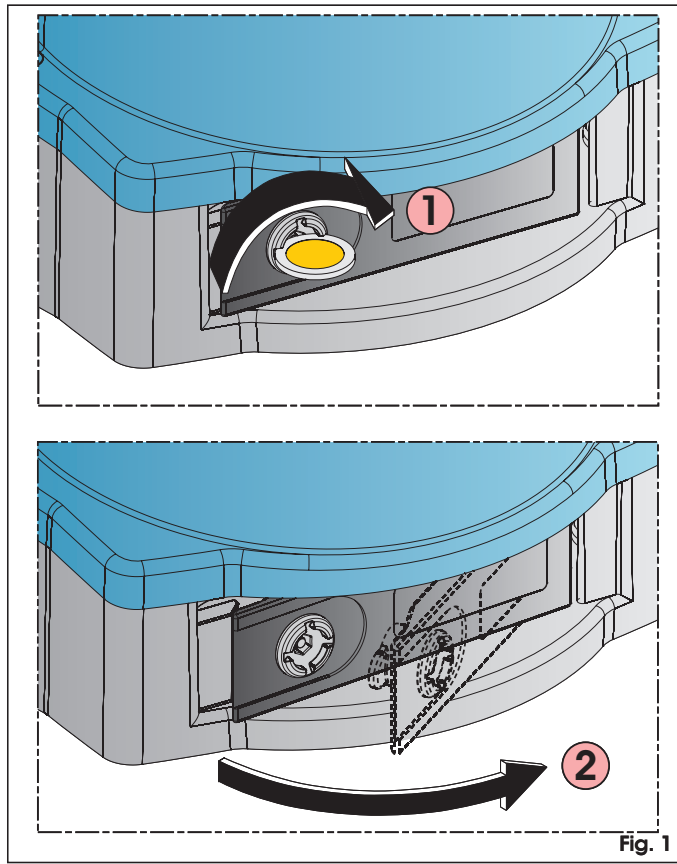

Fig. 1

RESTORING NORMAL OPERATING MODE.

1. Cut power to the system.
2. Position the gate at about halfway of opening travel
3. Take the release lever back into its position;
4. Using a coin, turn the lock anti-clockwise until it stops;
5. Restore power to the automated system.

👉 When power is restored, command another complete opening cycle.

⚠ Before sending a pulse, make sure that the gate cannot be moved manually.

