

EN TRANSLATION OF THE ORIGINAL INSTALLATION AND OPERATING MANUAL

Garage door operator

S 9050 pro / S 9050 pro+

S 9060 pro / S 9060 pro+

S 9080 pro / S 9080 pro+

S 9110 pro / S 9110 pro+

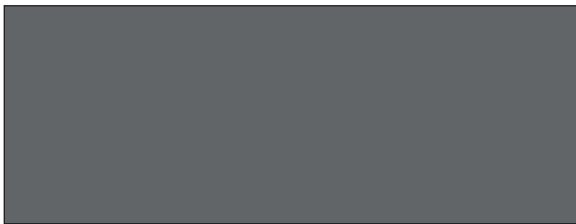

Download the current manual:



Dear customer,

Congratulations on your purchase of a product of

SOMMER Antriebs- und Funktechnik GmbH.

This product has been developed and manufactured under high standards of quality and with reference to ISO 9001.

Our passion for the product is just as important to us as the needs and requirements of our customers. We place particular emphasis on the safety and reliability of our products.

Read this installation and operating manual carefully and follow all instructions. This will ensure that you can install and operate the product safely and optimally.

If you have any questions, please contact your specialist retailer or installer.

Our products are intended for use by persons of all genders, even where this is not specifically stated.

Warranty

The warranty complies with statutory requirements. The contact person for warranties is the qualified dealer. The warranty is only valid in the country in which the operator was purchased. There is no warranty for consumables such as batteries, accumulators and safety products as well as light bulbs. This also applies for wear parts. The operator is only designed for a limited frequency of use. More frequent use leads to increased wear.

Contact data

If you require after-sales service, spare parts or accessories, please contact your qualified specialist retailer or installer.

Feedback on this Installation and Operating Manual

We have tried to make the Installation and Operating Manual as easy as possible to follow. If you have any suggestions as to how we could improve it or if you think more information is needed, please send your suggestions to us:



+49 (0) 7021 8001-403



doku@sommer.eu

Service

If you require service, please contact us on our service hotline (fee required) or see our web site:



+49 (0) 900 1800-150

• (0.14 euros/minute from land line telephones in Germany, mobile prices may vary)

www.sommer.eu/de/kundendienst.html

Copyright and proprietary rights

The manufacturer retains the copyright for this Installation and Operating manual. No part of this installation and operating manual may be reproduced in any form without the written permission of **SOMMER Antriebs- und Funktechnik GmbH** or processed, copied, or distributed using electronic systems. Violations of the above stipulations will lead to damage claims. All brands mentioned in this manual are the property of their respective manufacturer and hereby recognised as such.

Table of contents

1. About this Installation and Operating Manual	4
1.1 Storage and circulation of the Installation and Operating Manual	4
1.2 Important for translations	4
1.3 Description of the product type	4
1.4 Target groups of the Installation and Operating Manual	4
1.5 Explanation of symbols and notes	4
1.6 Special warning symbols and mandatory signs	5
1.7 Information regarding the depiction of text	5
1.8 Intended use of the operator	5
1.9 Improper use of the operator	6
1.10 Qualifications of personnel	6
1.11 Information for the user	7
2. General safety instructions	8
2.1 Basic safety instructions for operation	8
2.2 Additional safety information for the radio remote control	9
2.3 Information on operation and on radio remote control	9
2.4 Simplified Declaration of Conformity for radio systems	9
3. Description of function and product	10
3.1 The operator and its mode of operation	10
3.2 Safety equipment	10
3.3 Product designation	11
3.4 Explanation of tool symbols	11
3.5 Scope of delivery	12
3.6 Dimensions	13
3.7 Technical data	13
3.8 Overview of connection options	14
3.9 Door types and accessories	14
4. Tools and protective equipment	15
4.1 Required tools and personal protective equipment	15
5. Declaration of Installation	15
6. Installation	16
6.1 Important notes and information	16
6.2 Preparing for installation	17
6.3 Installing the drive system	18
6.4 Installing installation variant A or B of the drive system	19
6.5 Installing installation variant C of the drive system	21
6.6 Installation on the door	23
6.7 Installing the wall control unit	27
7. Removing and fastening covers	29
7.1 Cover of the motor carriage	29
7.2 Light and control unit cover of the wall control unit	30
8. Electrical connection	31
8.1 Connection to a power outlet	31

Table of contents

9. Initial operation	32	13. Operation	55
9.1 Important notes and information	32	13.1 Important notes and information	55
9.2 Carrying out automatic initial operation	32	13.2 Handover to the user	55
9.3 Carrying out manual initial operation	34	13.3 Operating modes of door movement	56
9.4 Detecting obstacles during the force programming run	34	13.4 Testing obstacle detection	56
9.5 Mechanical adjustment of the end positions	35	13.5 Power-saving mode	56
9.6 Attaching information sign and warning signs	36	13.6 In the event of a power failure	57
		13.7 Function of the emergency release	57
10. Connections and special functions of the motor carriage	37	14. Maintenance and care	59
10.1 Motor carriage circuit board	37	14.1 Important notes and information	59
10.2 Connection options on the motor carriage	38	14.2 Maintenance schedule	60
10.3 Reducing the illumination power of LEDs	39	14.3 Care	60
10.4 Explanation of the radio channels	39	15. Troubleshooting	61
10.5 Programming the transmitter	39	15.1 Important notes and information	61
10.6 Information on Memo	40	15.2 Troubleshooting	62
10.7 Cancelling programming mode	40	15.3 Time sequences of operator lighting in normal mode and in case of faults	63
10.8 Deleting a transmitter button from the radio channel	40	15.4 Troubleshooting table	64
10.9 Deleting transmitter completely from the receiver	40	15.5 Replacing the motor carriage	65
10.10 Deleting a radio channel in the receiver	40	16. Taking out of operation, storage and disposal	66
10.11 Deleting all radio channels in the receiver	41	16.1 Important notes and information	66
10.12 Programming a second handheld transmitter by radio (HFL)	41	16.2 Taking the operator out of operation and disassembly	66
10.13 Carrying out a reset	41	16.3 Storage	66
10.14 Setting the DIP switches on the motor carriage	42	16.4 Disposal of waste	67
10.15 Setting automatic closing function – defining basic values	42	17. Short instructions for installation	68
10.16 Setting the hold open time manually	43	18. Connection diagrams and functions of the DIP switches pro/pro+	72
10.17 Setting the lighting function	43		
10.18 Setting partial opening	44		
10.19 Deleting partial opening	44		
10.20 Wicket door safety device	44		
10.21 Connecting the safety contact strip	44		
10.22 12 V output	45		
10.23 SOMlink	45		
11. Connections and special functions of the wall control unit	46		
11.1 Wall control unit circuit board	46		
11.2 Connection options to the wall control unit	47		
11.3 Setting the DIP switches on the wall control unit	48		
11.4 Button assignment of wall control unit	48		
11.5 Button 2 for partial opening	49		
11.6 Photocell and frame photocell	49		
11.7 Wallstation	50		
11.8 Conex	51		
11.9 Output OC	51		
11.10 Relay	51		
11.11 Installing and removing the accumulator	51		
12. Function test and final test	53		
12.1 Testing obstacle detection	53		
12.2 Handover of the door system	54		

1. About this Installation and Operating Manual

1.1 Storage and circulation of the Installation and Operating Manual

Read this Installation and Operating Manual carefully and completely before installation, commissioning and operation and also before removal. Observe all warnings and safety instructions.

Keep this installation and operating manual accessible to all users at all times at the place of use. A replacement for the installation and operating manual can be downloaded from **SOMMER** at:

www.sommer.eu

During the transfer or resale of the operator to third parties, the following documents must be passed on to the new owner:

- EC Declaration of Conformity
- handover protocol and inspection book
- this Installation and Operating Manual
- proof of regular maintenance, testing and care
- documents recording retrofitting and repairs

1.2 Important for translations

The original installation and operating manual was written in German. The other available languages are translations of the German version. You can get the original Installation and Operating Manual by scanning the QR code.



<http://som4.me/orig-pro-plus-revg>

For other language versions, see:

www.sommer.eu

1.3 Description of the product type

The operator has been constructed according to the technological state-of-the-art and recognised technical regulations and is subject to the EC Machinery Directive 2006/42/EC.

The operator is fitted with a radio receiver. Optionally available accessories are also described. The version can vary depending on the type. This means the use of accessories can vary.



1.4 Target groups of the Installation and Operating Manual

The installation and operating manual must be read and observed by everyone assigned with one of the following tasks or using the device:

- Unloading and in-house transport
- Unpacking and installation
- Initial operation
- Setting
- Usage
- Maintenance, testing and care
- Troubleshooting and repairs
- Disassembly and disposal

1.5 Explanation of symbols and notes

The warnings in this installation and operating manual are structured as follows.

 Signal word	
	Type and source of hazard Consequences of the hazard ▶ Preventing/avoiding the hazard
Hazard symbol	



The hazard symbol indicates the hazard. The signal word is linked to a hazard symbol. The hazard is classified into three classes depending on its danger:



DANGER



WARNING

CAUTION

There are three different classifications of hazards.

 DANGER	
	Describes an immediate danger that leads to serious injury or death. Describes the consequences of the danger to you or other persons. ▶ Follow the instructions for avoiding/preventing the danger.

 WARNING	
	Describes a potential danger that may lead to fatal or serious injury. Describes the possible consequences of the danger to you or other persons. ▶ Follow the instructions for avoiding/preventing the danger.

 CAUTION	
	Describes a potential danger of a hazardous situation. Describes the possible consequences of the danger to you or other persons. ▶ Follow the instructions for avoiding/preventing the danger.

1. About this Installation and Operating Manual







The following symbols are used for notes and information:

NOTE

- Describes additional information and useful notes for correct use of the operator without endangering persons.
If this information is not observed, property damage or faults in the operator or door may occur.





 **INFORMATION**
Describes additional information and useful notes for optimum use of the operator.

The following symbols are used in the figures and text.



-  Continue reading the Installation and Operating Manual for more information.
-  Disconnect the operator from the mains voltage
-  Connect the operator to the mains voltage
-  Factory setting,
as-delivered state depending on version
-  Connection to a WiFi-enabled device via SOM-link
-  Operator components must be disposed of properly
-  Old accumulators and batteries must be disposed of properly

1.6 Special warning symbols and mandatory signs

To specify the source of danger more precisely, the following symbols are used together with the above-mentioned hazard symbols and signal words. Follow the instructions to prevent a potential hazard.

-  **Danger due to electric current!**
-  **Danger of falling!**
-  **Danger due to falling parts!**
-  **Danger of entrapment!**
-  **Danger of crushing and shearing!**
-  **Danger of tripping and falling!**
-  **Danger due to optical radiation!**

The following mandatory signs are used for the respective actions. The requirements described must be complied with.

-  **Wear personal safety glasses**
-  **Wear a personal safety helmet**
-  **Wear personal safety gloves**

1.7 Information regarding the depiction of text

1. Stands for directions for an action
⇒ Stands for the results of the action

Lists are shown as a list of actions:

- List 1
- List 2

1, A **1** A Item number in the figure refers to a number in the text

Important text items, for example in directions for actions, are emphasised in **bold** type.

References to other chapters or sections are in **bold** type and set in "quotation marks."

1.8 Intended use of the operator

The operator is intended exclusively to open and close doors. Any other use does not constitute intended use.

The manufacturer accepts no liability for damage resulting from use other than intended use. The user bears the sole responsibility for any risk involved. It also voids the warranty.

Any changes to the operator must be made with original **SOMMER** accessories only and only to the extent described. For more information on accessories, see:



<https://downloads.sommer.eu/>

1. About this Installation and Operating Manual

Doors automated with this operator must comply with all valid international and domestic standards, directives and regulations. These include EN 12604 and EN 13241-1.

The operator may only be used:

- in combination with door types in the reference list which can be found at:



<http://som4.me/cgdo>

- if the EC Declaration of Conformity has been issued for the door system
- if the CE mark and the type plate for the door system have been attached to the door
- if the handover protocol and the inspection book have been completed and are available
- if the installation and operating manuals for the operator and the door are present
- as specified in this Installation and Operating Manual
- in good technical condition
- with an awareness of the safety hazards and risks involved and by trained users.

After installation of the operator, the person responsible for the installation of the operator must complete an EC Declaration of Conformity for the door system in accordance with Machinery Directive 2006/42/EC and apply the CE mark and a type plate to the door system. This also applies if the operator is retrofitted to a manually operated door. In addition, a handover protocol and an inspection book must be completed.

The following are available:

- EC Declaration of Conformity
- handover protocol for the operator



<http://som4.me/konform>

1.9 Improper use of the operator

Any other use or additional use that has not been described in Chapter 1.8 constitutes improper use. The user bears the sole responsibility for any risk involved.

The manufacturer's warranty will be voided by:

- damage caused by other use and improper use
- use with defective parts
- unauthorised modifications to the operator
- modifications and non-approved programming of the operator and its components

The door must not be part of a fire protection system, an escape route or an emergency exit that automatically closes the door in the event of fire. Installation of the operator will prevent automatic closing.

Observe the local building regulations.

The operator may not be used in:

- areas with explosion hazard
- very salty air
- aggressive atmosphere, including chlorine

1.10 Qualifications of personnel

Qualified specialist for installation, commissioning and disassembly

This Installation and Operating Manual must be read and complied with by a **qualified specialist** who installs or performs maintenance on the operator.

Work on the electrical system and live parts must be performed by a **trained electrician** in accordance with EN 50110-1.

The installation, initial operation and disassembly of the operator may only be performed by a qualified specialist. A qualified specialist is a person commissioned by the installer.

The qualified specialist must be familiar with the following standards:

- EN 13241-1 Doors and gates - Product standard
- EN 12604 Doors and gates - Mechanical aspects - Requirements and test methods
- EN 12453: Safety in use of power-operated doors 2017 (Plc)

When all work has been completed, the qualified specialist must:

- issue an EC Declaration of Conformity
- attach the CE mark and the type plate to the door system.

Instructing the user and handing over documents

The qualified specialist must instruct the user:

- on the operation of the operator and its dangers
- on the handling of the manual emergency release
- on regular maintenance, testing and care which the user can carry out

The qualified specialist must inform the user which work may only be carried out by a qualified specialist:

1. About this Installation and Operating Manual

- installation of accessories
- settings
- regular maintenance, testing and care which can be carried out by the user, except that described in Chapter **"14. Maintenance and care"**
- troubleshooting which can be carried out by the user, except that described in Chapter **"15. Troubleshooting"**.

1.11 Information for the user

The user must ensure that the CE mark and the type plate have been attached to the door system.

The following documents for the door system must be handed over to the user:

- EC Declaration of Conformity
- handover protocol and inspection book
- the installation and operating manuals for the operator and the door

The user is responsible for:

- keeping this Installation and Operating Manual accessible at all times at the place of use
- the intended use of the operator
- its good condition
- instructing all users on how to use the operator, the associated risks and the emergency release
- operation
- regular maintenance, testing and care, except that described in Chapter **"14. Maintenance and care"** and which must be carried out by a qualified specialist
- troubleshooting, except that described in Chapter **"15. Troubleshooting"** and which must be carried out by a qualified specialist

The operator must not be used by persons with restricted physical, sensory or mental capacity or who lack experience and knowledge. All users must be specially instructed and have read and understood the Installation and Operating Manual.

Children must never play with or use the operator, even under supervision. Children must be kept clear of the operator. Handheld transmitters or other command devices must never be given to children. Handheld transmitters must be safely stored and protected against unintended and unauthorised use.

The user must ensure compliance with the accident prevention regulations and the applicable standards.

The guideline "Technical regulations for workplaces ASR A1.7" of the German committee for workplaces (ASTA) is applicable for commercial use. The guidelines described must be observed and complied with. In other countries, the user must comply with the applicable national regulations.

2. General safety instructions

2.1 Basic safety instructions for operation

Follow the basic safety instructions listed below.

Danger if not observed!

If safety instructions are not observed, serious injury or death may result.

- ▶ All safety instructions must be complied with.

Danger due to electric current!

Contact with live parts may result in electric current flowing through the body. Electric shock, burns or death will result.

- ▶ Installation, testing and replacement of electrical components must be carried out by a **trained electrician**.
- ▶ Disconnect the mains plug before working on the operator.
- ▶ If an accumulator is connected, disconnect it from the control unit.
- ▶ Check that the operator is not live.
- ▶ Secure the operator against being switched back on.

Danger due to use of the operator with incorrect settings or when it is in need of repair!

If the operator is used despite incorrect settings or if it is in need of repair, severe injury or death may result.

- ▶ The operator may only be used with the required settings and in the proper condition.
- ▶ You must have faults repaired professionally without delay.

Danger of hazardous substances!

Improper storage, use or disposal of accumulators, batteries and operator components are dangerous for the health of humans and animals. Serious injury or death may result.

- ▶ Accumulators and batteries must be stored out of the reach of children and animals.
- ▶ Keep accumulators and batteries away from chemical, mechanical and thermal influences.
- ▶ Do not recharge old accumulators and batteries.
- ▶ Components of the operator as well as old accumulators and batteries must not be disposed of with household waste. They must be disposed of properly.

Danger for trapped persons!

Persons may be trapped inside the garage. If trapped persons cannot free themselves, severe injury or death may result.

- ▶ Check the function of the emergency release at monthly intervals, **particularly** from inside in the door CLOSE end position and if necessary, also from outside.
- ▶ You must have faults repaired professionally without delay.

Danger due to projecting parts!

Parts must not project into public roads or footpaths. This also applies while the door is moving. Persons and animals may be seriously injured.

- ▶ Keep public roads and footpaths clear of projecting parts.
-

Danger due to falling parts of doors!

Actuating the emergency release can lead to uncontrolled door movement if

- Springs are weakened or broken.
 - The door has not been optimally weight-balanced.
- Falling parts may cause a hazard. Severe injuries or death may result.
- ▶ Check the weight balance of the door at regular intervals.
 - ▶ Pay attention to the movement of the door when the emergency release is actuated.
 - ▶ Keep clear of the movement area of the door.

Danger of entrapment!

Persons or animals in the movement area of the door may be trapped and pulled along with the door. Severe injuries or death may result.

- ▶ Keep clear of the movement area of the door.

Danger of crushing and shearing!

If the door moves and there are persons or animals in the movement area, crushing and shearing injuries may be caused by the mechanism and safety edges of the door.

- ▶ Only use the operator when you have a direct view of the door.
- ▶ All danger zones must be visible during the entire door operation.
- ▶ Always keep the moving door in sight.
- ▶ Keep persons and animals clear of the range of movement of the door.
- ▶ Never put your hand near the door when it is moving or near moving parts. In particular, do not reach into the moving push arm.
- ▶ Do not reach into the ceiling suspension unit when the motor carriage is running along the track.
- ▶ Do not drive through the door until it has opened completely.
- ▶ Store the handheld transmitter so that unauthorised or accidental operation, e.g., by children or animals, is impossible.
- ▶ Never stand under the opened door.

Danger due to optical radiation!

Looking into an LED at short range for an extended period may cause optical glare. This may temporarily reduce vision. This may cause serious or fatal accidents.

- ▶ Never look directly into an LED.

Risk of eye injury!

Chips flying when drilling may cause serious injuries to eyes and hands.

- ▶ Wear safety glasses when drilling.

Risk of injury in the head region

Impact with suspended objects may cause serious abrasions and cuts.

- ▶ You must wear a safety helmet when installing suspended parts.
-

2. General safety instructions

Risk of injury to hands!

Rough metal parts may cause abrasions and cuts when picked up or touched.

- ▶ Wear safety gloves when deburring or performing similar work.

2.2 Additional safety information for the radio remote control

Follow the basic safety instructions listed below.

Danger of crushing and shearing!

If the door is not visible and the radio control is operated, crushing and shearing injuries to persons or animals may be caused by the mechanism and safety edges of the door.

- ▶ In particular when operating control elements such as the radio remote control, all danger zones must be visible during the entire door operation.
- ▶ Always keep the moving door in sight.
- ▶ Keep persons and animals clear of the range of movement of the door.
- ▶ Never put your hand near the door when it is moving or near moving parts.
- ▶ Do not drive through the door until it has opened completely.
- ▶ Store the handheld transmitter so that unauthorised or accidental operation, e.g., by children or animals, is impossible.
- ▶ Never stand under the opened door.

2.3 Information on operation and on radio remote control

The user of the radio system is not protected against interference due to other telecommunications equipment or devices. This includes radio-controlled systems that are licensed to operate in the same frequency range. If significant interference occurs, please contact your appropriate telecommunications office which has radio interference measuring equipment or radio location equipment.

NOTE

- The motor carriage is supplied with safety low voltage via the chain and the track.
The use of oil or grease will greatly reduce the conductivity of the chain, track and motor carriage. This may result in faults due to inadequate electrical contact.
The chain and track are maintenance-free and must not be oiled or greased.
- Objects in the movement area of the door may be jammed and damaged.
Objects must not be in the range of movement of the door.
- If the door is not in view and the radio remote control is actuated, objects in the movement area of the door may be jammed and damaged.
Objects must not be in the range of movement of the door.

- Dispose of all components in accordance with local and national regulations to avoid environmental damage.



INFORMATION

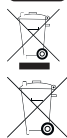

- All components that have been taken out of service, old accumulators and operator batteries must not be disposed of with household waste. Dispose of components which are no longer in use, old accumulators and batteries properly. You must observe the local and national regulations.

2.4 Simplified Declaration of Conformity for radio systems

SOMMER Antriebs- und Funktechnik GmbH hereby declares that the radio system (pro and pro+) complies with Directive 2014/53/EU. You can see the full text of the EU Declaration of Conformity for the radio system at:



<http://som4.me/konform-funk>

3. Description of function and product

3.1 The operator and its mode of operation

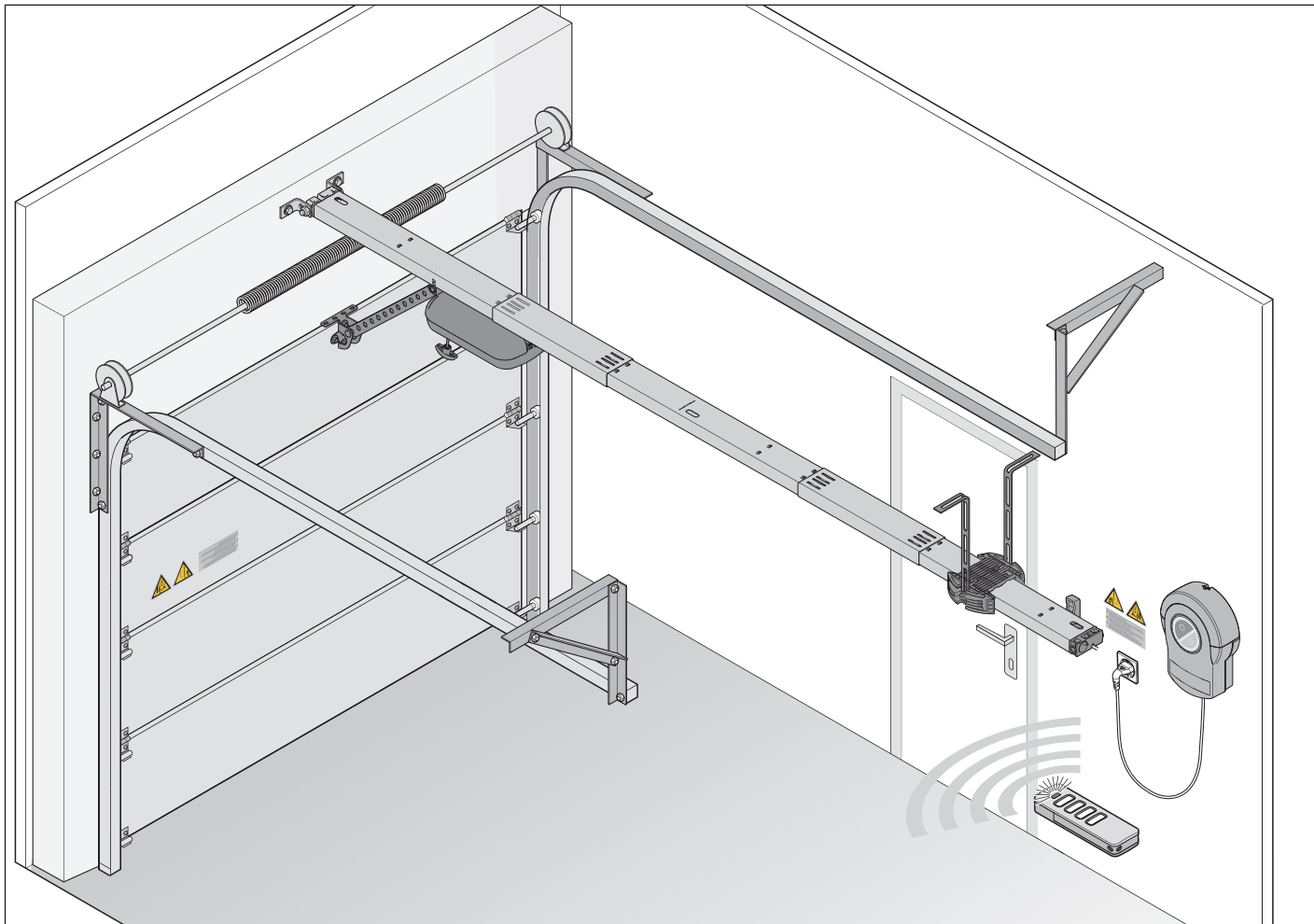

Fig. Door structure with operator, using the example of a sectional door

Sectional doors and other door types can be opened and closed with the electrically powered operator and its available accessories. The operator can be controlled with a handheld transmitter. The door can be opened and closed with the membrane keypad of the wall control unit.

The track is mounted on the ceiling and the lintel above the garage door. The motor carriage is attached to the door by a push arm. The motor carriage moves along the track on a spring-mounted chain and opens or closes the door.

The handheld transmitter can be stored in a holder in the garage or in the vehicle.

3.2 Safety equipment

The operator stops and reverses slightly if it encounters an obstacle. This prevents injury and damage to property. The door will be partially or completely opened, depending on the setting.

In the event of a power failure, the door can be opened from the inside via an emergency release handle or from the outside with a Bowden wire or emergency release lock.

3. Description of function and product

3.3 Product designation

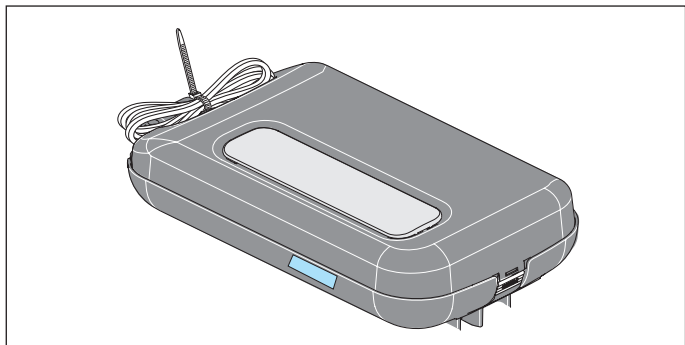

Fig. Motor carriage with type plate and device specifications

The type plate includes:

- type designation
- Item Number
- date of manufacture with month and year
- serial number

In case of questions or service, please supply the type designation, the date of manufacture and the serial number.

3.4 Explanation of tool symbols

Tool symbols

These symbols refer to the use of tools required for installation.



Phillips screwdriver



Metal drill 5 mm



Masonry drill 6/10 mm



Fork wrench 17 mm



Ratchet wrench 13/17 mm

Other symbols



Drilling depth



Audible engaging or clicking noise

3. Description of function and product

3.5 Scope of delivery

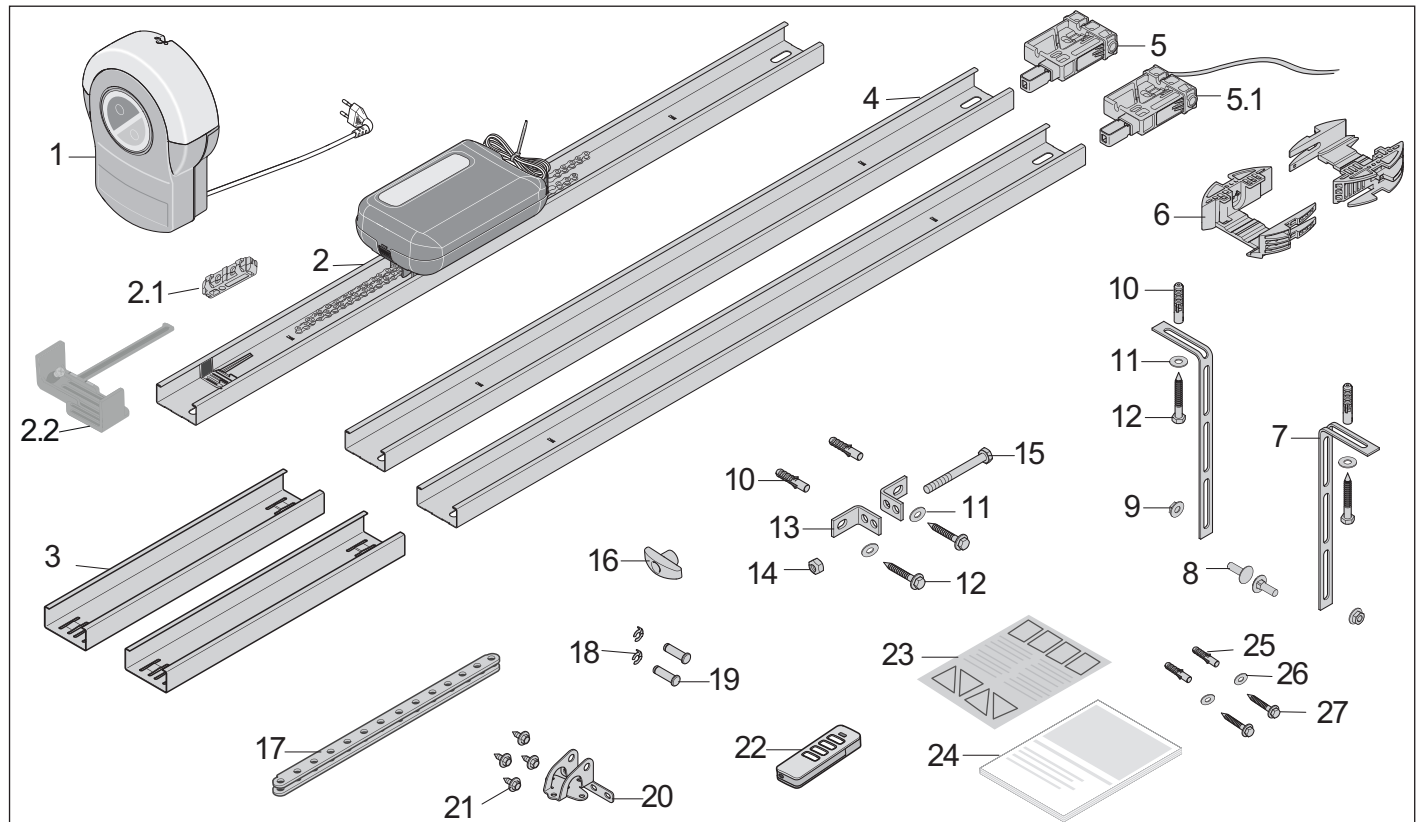

Fig. Scope of delivery

- | | |
|---|---|
| <ul style="list-style-type: none"> 1) Wall control unit 2) Track, pre-assembled with 1 x limit stop, chain and motor carriage 2.1) Isolator, included with the track 2.2) Limit stop, pre-assembled on the track 3) Connecting sleeve, 2x 4) Track, 2x 5) Plug-in unit, pre-assembled 5.1) Plug-in unit, pre-assembled, with control cable, 2-wire, approx. 5 m 6) Ceiling holder, 2-part 7) Perforated strip, angled, 2x 8) Screw M8 x 20 mm, 2x 9) Hexagonal nut, self-locking M8, 2x 10) S10 plug, 4x 11) Washer, 4x 12) Screw 8 x 60 mm, 4x 13) Lintel bracket, 2x 14) Hexagonal nut, self-locking M10 15) Hexagonal head screw M10 x 100 mm | <ul style="list-style-type: none"> 16) Emergency release handle 17) Push arm, straight 18) Bolt lock 10 mm, 2x 19) Bolt 10 x 34.5 mm, 2x 20) Door bracket 21) Combination self-tapping screw, 4x 22) Handheld transmitter, preprogrammed, channel 1 pulse sequence, with CR 2032 3V lithium battery 23) Information sticker for garage interior 24) Installation and Operating Manual <p>Mounting for the wall control unit</p> <ul style="list-style-type: none"> 25) S6 plug, 2x 26) Washer, 2x 27) Screw \varnothing 4 x 50 mm, 2x <p>When unpacking, make sure that all items are included in the packages. The actual scope of delivery may vary depending on the specific version.</p> |
|---|---|

3. Description of function and product

3.6 Dimensions

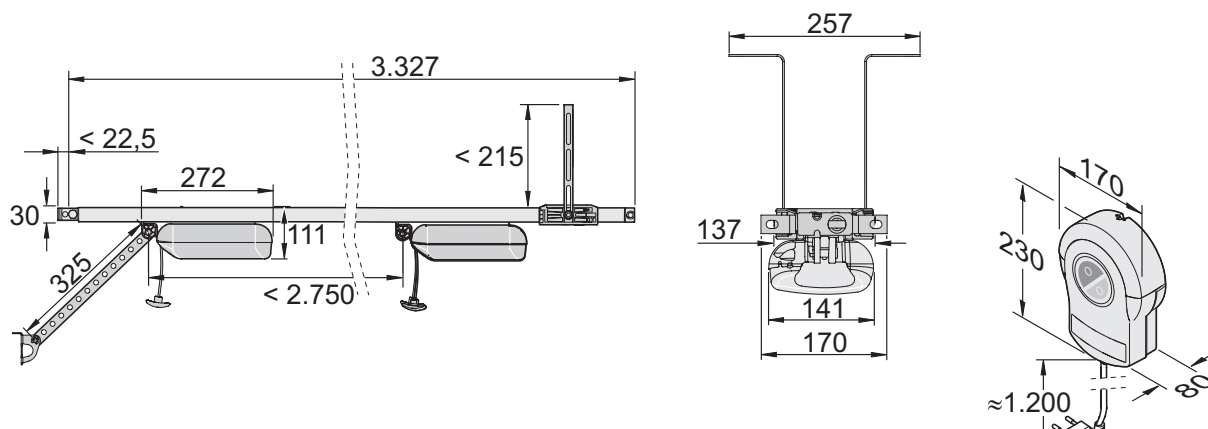

Fig. Dimensions (all dimensions are in mm)

3.7 Technical data

	S 9050 pro/pro+	S 9060 pro/pro+	S 9080 pro/pro+	S 9110 pro/pro+	
Rated voltage	AC 220–240 V				
Rated frequency	50/60Hz				
Rating	3 cycles or 4 minutes				
Memory positions in radio receiver	40				
Duty cycle	S3 = 40%				
Operating temperature	-25 °C ... +65 °C				
Emission value according to operating environment	< 59 dB(A) – operator only				
IP protection class	IP21				
IP-code	II				
Max. travel length	2,750 mm				
Max. travel length incl. extension	3,800 mm (1x 1,096 mm)	4,900 mm (2x 1,096 mm)	6,000 mm (3x 1,096 mm)	7,100 mm (4x 1,096 mm)	
Max. speed*	180 mm/s	240 mm/s	210 mm/s	180 mm/s	
Max. pull and pushing force	500 N	600N	800 N	1,100 N	
Rated pull force	150 N	180 N	240 N	330 N	
Max. current consumption	0.8 A	0.8 A	0.9 A	0.9 A	
Rated current consumption**	0.7 A	0.8 A	0.8 A	0.8 A	
Max. power consumption	195 W	205 W	185 W	175 W	
Rated power consumption**	130 W	150 W	170 W	165 W	
Power consumption in power-saving mode	<3 W pro/<1 W pro+				
Max. door weight*	approx. 80 kg	approx. 120 kg	approx. 160 kg	approx. 200 kg	
Max. door width/door height***	Sectional doors	3,000 mm/ 2,500 mm	4,500 mm/ 2,500 mm	6,000 mm/ 2,500 mm	8,000 mm/ 2,500 mm
	One piece doors	3,000 mm/ 2,750 mm	4,500 mm/ 2,750 mm	6,000 mm / 2,750 mm	8,000 mm/ 2,750 mm
	Up-and-over doors	3,000 mm/ 2,050 mm	4,500 mm/ 2,050 mm	6,000 mm / 2,050 mm	8,000 mm/ 2,050 mm
	Hinged double doors	2,800 mm/ 2,300 mm	2,800 mm/ 2,500 mm	2,800 mm/ 2,750 mm	2,800 mm/ 3,000 mm
	Side-opening sectional doors/ Side-opening doors	2,500 mm/ (3,000 mm)/ 2,300 mm	2,500 mm / (4,500 mm) / 2,500 mm	2,500 mm/ (5,750 mm)/ 2,750 mm	2,500 mm/ (6,850 mm)/ 3,000 mm
Max. no. of spaces	2	30	50	30	

* Depending on door and the operating conditions

** Values apply without lighting, Lumi pro+

*** Reference value, depending on the door construction

3. Description of function and product

3.8 Overview of connection options

Only **SOMMER** accessories may be used. Observe the corresponding instructions.

Accessories may only be installed and adjusted by qualified specialists. The use of accessories can vary depending on the type.

Motor carriage	pro	pro+
LED	3	6
Lock		•
Memo		•
USART	•	•
Senso		•
Buzzer	•	•
Laser		•
Motion for OSE/8k2		•
Wicket door contact	•	•
Output 12 V, 100 mA		•
DIP switches	4	4

Wall control unit	pro	pro+
Accumulator		•
Keypad (Conex connection)	•	•
Relay / Output OC	•	•
Lumi ⁺	•	•
Pulse button	•	•
Button 2 (partial opening)		•
Warning light, 24 V/25 W	•	•
2-/4-wire photocell	•	•
Output DC 24 V	•	•
DIP switches	•	4
Wallstation	•	•

A SOMlink is also available as an additional accessory. For more information on accessories, see:



<https://downloads.sommer.eu/>

3.9 Door types and accessories

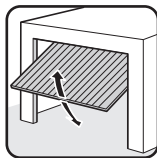
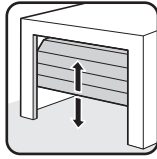
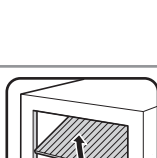
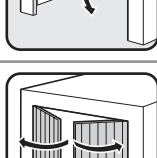
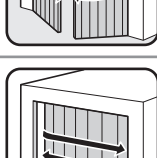
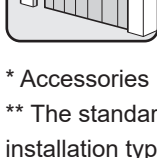
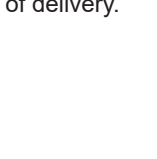
Door type	Accessories
 One piece door	No accessories required
 Sectional door with single track	Sectional door fitting with curved push arm*
 Sectional door with double track	Sectional door fitting without curved push arm**
 Sectional overhead door	No accessories required
 Up-and-over door	Curved arm*
 Hinged double door	Hinged double door fitting*
 Side-opening door, side-opening sectional door	Side-sectional door fitting**

* Accessories not included in the scope of delivery

** The standard fitting can also be used depending on the installation type. Custom fittings are not included in the scope of delivery.

4. Tools and protective equipment

4.1 Required tools and personal protective equipment

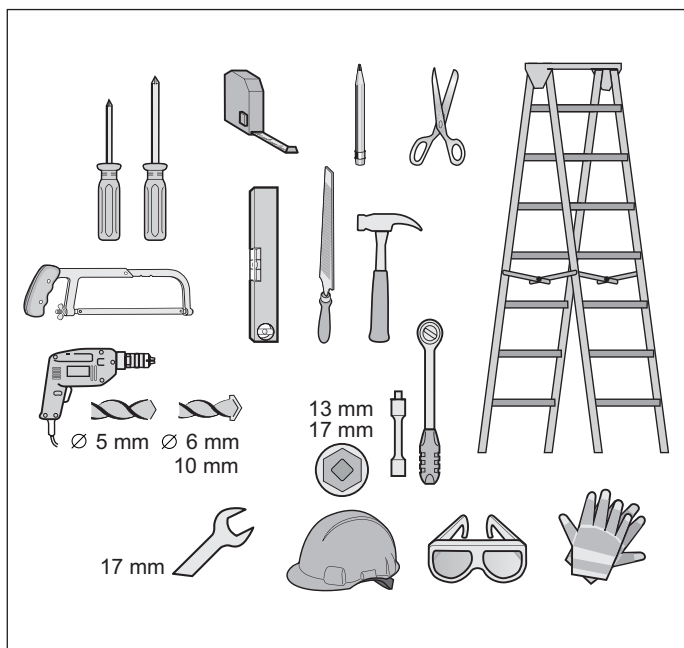

Fig. Recommended tools and personal protective equipment for installation

You will require the tools shown above to assemble and install the operator. Lay out the required tools beforehand to ensure fast and safe installation.

Wear your personal protective equipment. This includes safety glasses, safety gloves and a safety helmet.

5. Declaration of Installation

Declaration of Installation

for installation of an incomplete machine in accordance with the Machinery Directive 2006/42/EC, Annex II, Part 1 B

SOMMER Antriebs- und Funktechnik GmbH

Hans-Böckler-Straße 21-27

D-73230 Kirchheim/Teck

Germany

hereby declares that the control units

**S 9050 base; S 9060 base; S 9080 base; S 9110 base;
S 9050 base+ S 9060 base+; S 9080 base+; S 9110 base+;
S 9050 pro; S 9060 pro; S 9080 pro; S 9110 pro; S 9050
pro+; S 9060 pro+; S 9080 pro+; S 9110 pro+**

have been developed, designed and manufactured in conformity with the:

- Machinery Directive 2006/42/EC
- Low Voltage Directive 2014/35/EU
- Electromagnetic Compatibility Directive 2014/30/EU
- RoHS Directive 2011/65/EU

The following standards were applied:

- | | |
|------------------|--|
| EN ISO 13849-1, | Safety of machines - Safety-related parts of controls |
| PL "C" Cat. 2 | - Part 1: General design guidelines |
| EN 60335-1, | Safety of electrical appliances/operators for doors |
| where applicable | |
| EN 61000-6-3 | Electromagnetic compatibility (EMC) - interference |
| EN 61000-6-2 | Electromagnetic compatibility (EMC) - interference resistance |
| EN 60335-2-95 | General safety requirements for household and similar electrical appliances |
| | - Part 2: Particular requirements for operators for vertically moving garage doors for residential use |
| EN 60335-2-103 | General safety requirements for household and similar electrical appliances |
| | - Part 2: Special requirements for operators for gates, doors and windows |

The following requirements of Annex 1 of the Machinery Directive 2006/42/EC are met: 1.1.2, 1.1.3, 1.1.5, 1.2.1, 1.2.2, 1.2.3, 1.2.4, 1.2.5, 1.2.6, 1.3.1, 1.3.2, 1.3.4, 1.3.7, 1.5.1, 1.5.4, 1.5.6, 1.5.14, 1.6.1, 1.6.2, 1.6.3, 1.7.1, 1.7.3, 1.7.4

The special technical documentation was prepared in accordance with Annex VII Part B and will be submitted to regulators electronically on request.

The operator may only be used:

- in combination with door types in the reference list, which can be found under Certifications:
www.sommer.eu

The incomplete machine is intended for installation in a door system only to form a complete machine as defined by the Machinery Directive 2006/42/EC. The door system may only be put into operation after it has been established that the complete system complies with the regulations of the above EC Directives.

The undersigned is responsible for compilation of the technical documents.

Kirchheim/Teck,
20.04.2016



i.v.

Jochen Lude

Jochen Lude
Responsible for documents

6. Installation

6.1 Important notes and information

In particular, please observe and comply with the following warnings, notes and information to ensure safe installation.

DANGER



Danger if not observed!

If warnings are not observed, serious injury or death may result.

- ▶ All warnings must be complied with.

WARNING



Danger of falling!

Unsafe or defective ladders may tip and cause serious or fatal accidents.

- ▶ Use only a non-slip, stable ladder.
- ▶ Ensure that ladders are safely positioned.



Danger for trapped persons!

Persons may be trapped inside the garage. If trapped persons cannot free themselves, severe injury or death may result.

- ▶ Check the function of the emergency release at monthly intervals, **particularly** from inside in the door CLOSE end position and if necessary, also from outside.
- ▶ If there is no second entrance to the garage, you must have a release lock or a Bowden wire for unlocking from the outside installed. This can be used to free persons who cannot free themselves.



Danger due to projecting parts!

Door leaves or other parts must not project into roads or public footpaths. This also applies while the door is moving. This may cause serious injury or death to persons or animals.

- ▶ Keep public roads and footpaths clear of projecting parts.



Danger due to falling parts of doors!

If a door is incorrectly balanced, springs may break suddenly. Falling door parts may cause serious injury or death.

Check:

- ▶ The stability of the door.
- ▶ That the door does not bend, rotate or twist when you open or close it.
- ▶ That the door runs smoothly in the tracks.



Danger due to falling ceiling and wall parts!

The operator cannot be installed correctly if ceiling and walls are unstable or if unsuitable mounting materials are used. Persons or animals may be struck by falling parts of the wall, ceiling or operator. Severe injuries or death may result.

- ▶ You must test the stability of the ceiling and the walls.
- ▶ Use only permissible mounting materials appropriate for the supporting surface.



Danger of entrapment!

Loose clothing or long hair may be trapped by moving parts of the door. Severe injuries or death may result.

- ▶ Keep clear of the moving door.
- ▶ Always wear tight-fitting clothing.
- ▶ Wear a hairnet if you have long hair.



Danger of crushing and shearing!

If the door moves and there are persons or animals in the movement area, crushing and shearing injuries may be caused by the mechanism and safety edges of the door.

- ▶ Only use the operator when you have a direct view of the door.
- ▶ All danger zones must be visible during the entire door operation.
- ▶ Always keep the moving door in sight.
- ▶ Keep persons and animals clear of the range of movement of the door.
- ▶ Never put your hand near the door when it is moving or near moving parts. In particular, do not reach into the moving push arm.
- ▶ Do not reach into the ceiling suspension unit when the motor carriage is running along the track.
- ▶ Do not drive through the door until it has opened completely.
- ▶ Never stand under the opened door.



Danger of tripping and falling!

Unsafely positioned parts such as packaging, operator parts or tools may cause trips or falls.

- ▶ Keep the installation area free of unnecessary items.
- ▶ Place all parts where no-one is likely to trip or fall over them.
- ▶ The general workplace guidelines must be observed.



Risk of eye injury!

Chips flying when drilling may cause serious injuries to eyes and hands.

- ▶ Wear safety glasses when drilling.



6. Installation



Risk of injury in the head region!

Impact with suspended objects may cause serious abrasions and cuts.



- ▶ You must wear a safety helmet when installing suspended parts.



CAUTION



Risk of injury to hands!

Rough metal parts may cause abrasions and cuts when picked up or touched.



- ▶ Wear safety gloves when deburring or performing similar work.

NOTE

- If the ceiling and walls are not stable, parts of the ceiling and wall or the operator may fall. Objects may be damaged.
Ceiling and walls must be stable.
- To prevent damage to the door or operator, use only approved mounting materials such as wall plugs or screws.
The mounting material must be suitable for the material of the ceiling and walls. This applies particularly for prefabricated garages.

6.2 Preparing for installation

Before installation, you must check whether the operator is suitable for the door, see also Chapter "3.7 Technical data".

Removal of actuation parts



WARNING



Danger of entrapment!

Persons or animals may be trapped by straps or cords and pulled into the movement zone of the door. Severe injuries or death may result.

- ▶ Remove straps and cords used for mechanical actuation of the door.

Before installation remove:

- manual locking on door
- all cords or straps necessary to operate the door by hand.

Disabling mechanical locks

NOTE

- If locks or other locking systems are installed on a mechanical door, they may block the operator. This may cause faults or damage to the operator.
- Before the installation of the operator, all mechanical locking systems must be disabled.

The mechanical lock on a door with an operator must be removed or disabled if it is not compatible with the operator.

Checking the mechanism and weight balance



WARNING



Danger due to falling parts of doors or complete door panels!

Wires, spring sets and other fittings can be damaged and break. The complete door panel can fall.

Persons or animals may be struck by falling parts of the door or the complete door panel. Severe injuries or death may result.

Before installation, a **qualified specialist** must check and, if necessary, adjust the following:

- ▶ Wires, spring sets and other fittings of the door.
- ▶ The weight balance of the door.



WARNING



Danger of entrapment!

If the force setting is too high, persons or animals in the movement area of the door may be trapped and pulled along with the door. Severe injuries or death may result.

- ▶ The force setting is relevant to safety and must be carried out by a **qualified specialist**.
- ▶ You must proceed with extreme caution if you check and if necessary adjust the force setting.

NOTE

If the weight compensation of the door is incorrectly adjusted, the operator may be damaged.

- The door must be stable.
- It must not bend, rotate or twist when opening and closing.
- The door must move easily in its tracks.

1. Check the mechanisms of the door, such as cables, spring sets and other fittings.

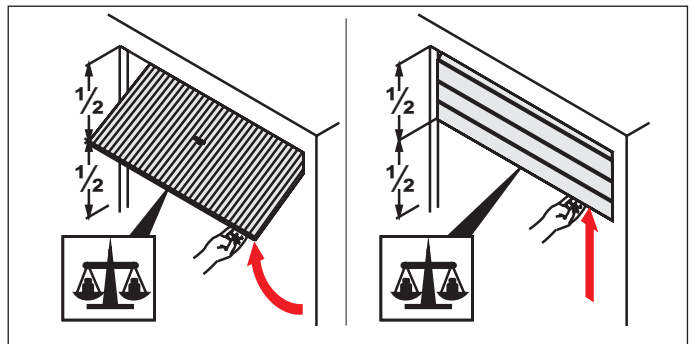

Fig. 2

6. Installation

2. Open the door halfway.
 - ⇒ The door must remain in this position.
 - ⇒ The door must be moved easily by hand and must be balanced.

If the door moves upwards or downwards by itself, the weight balance of the door must be adjusted.

Emergency release

In a garage without a separate entrance (e.g. wicket doors), the operator's emergency release must be operable from outside. The emergency release must also be routed to be accessible from the outside. This can be done with a Bowden wire or a release lock.



INFORMATION

- The emergency release must be easy to operate in all necessary positions.
- In particular, unlocking must be possible in door CLOSE.

6.3 Installing the drive system

Selecting the installation variant

The scope of delivery offers the option of implementing the following installation variants. Check your specific situation and select the optimum installation variant for you.

Installation situation A, B and C

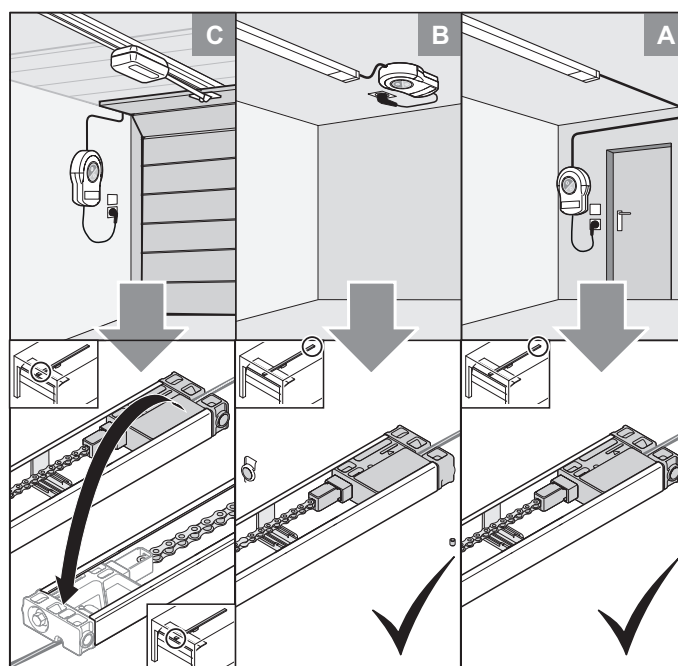

Fig. Installation variant A, B and C

Installation variant A

This variant is selected if there is a separate entrance to the garage. The wall control unit is installed near a power outlet. The integrated membrane keypad of the wall control unit can be used to open the door when entering the garage or to close the door when leaving the garage. The control cable is led out at the rear end of the track; see Chapter "6.4 Installing installation variant A or B of the drive system".

Installation variant B

This variant is selected when an existing device is being replaced by a new one and there is already a power outlet or other control lines such as buttons or photocells in this area. Here, the wall control unit is mounted on the ceiling in the rear area of the track. The control cable of the plug-in unit is also led out at the rear end of the track; see Chapter "6.4 Installing installation variant A or B of the drive system".

6. Installation

Installation variant C

This version is selected when there is a power outlet which can be used for the wall control unit located near the door opening. Here, the control cable is led out at the front end of the track; see Chapter "6.4 Installing installation variant A or B of the drive system".

6.4 Installing installation variant A or B of the drive system

The operator may only be installed if the installation requirements and dimensions below are correct.

NOTE

- Specify the position for mounting the operator on the door. Manually open and close the door several times. The door must be moved easily. A manual movement force of 150 N is applicable for private garage doors and 260 N for commercial doors. The value is applicable for the entire life of the door. The door must also be maintained and inspected as specified by the door manufacturer.

INFORMATION

- Before installation, check whether the garage is suitable for the operating temperature indicated on the motor carriage.

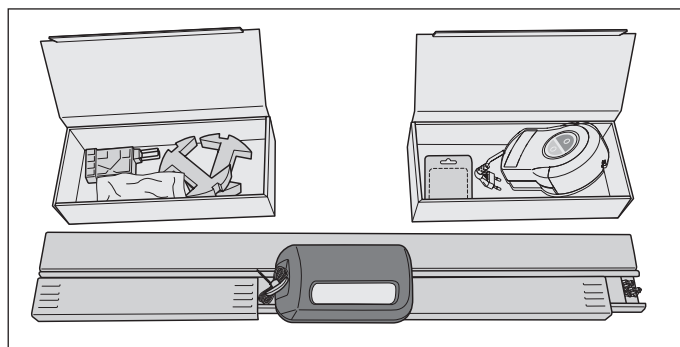

Fig. 1

CAUTION! Risk of injury to hands

Rough metal parts may cause abrasions and cuts when picked up or touched.

- ▶ You must wear safety gloves when working with rough metal parts.

1. Open the package.
Place the two cartons in the package beside the tracks and open them.
Check the entire contents against the scope of delivery, see Chapter "3.5 Scope of delivery".

6. Installation

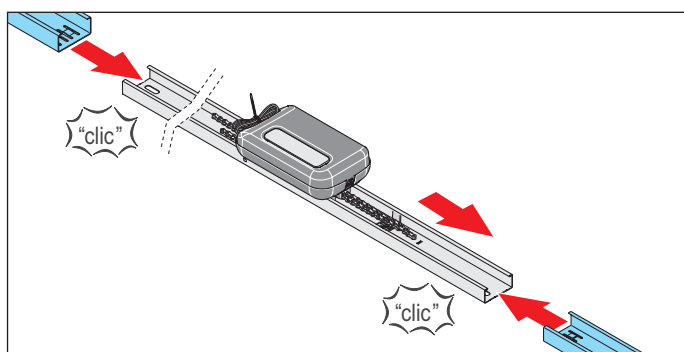

Fig. 2

2. Remove the two connecting sleeves beside the motor carriage and attach to the track on the left and right.

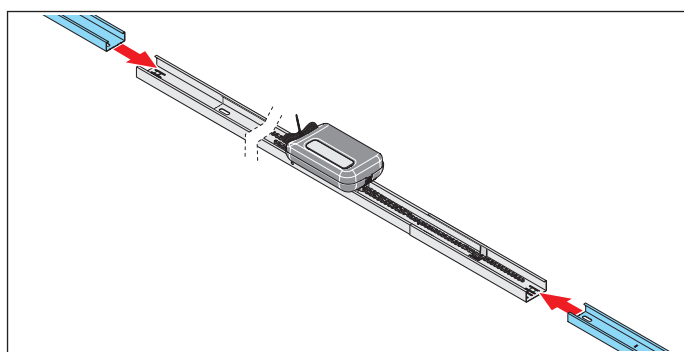

Fig. 3

3. Attach a track to each of the connecting sleeves.

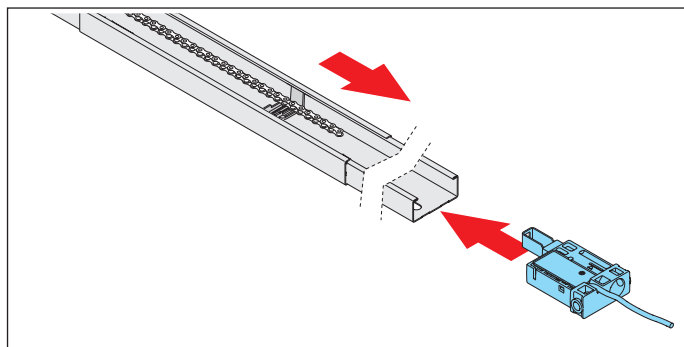

Fig. 4

4. Plug the **plug-in unit with control cable** into the track behind the limit stop.
Lay the chain over the limit stop.

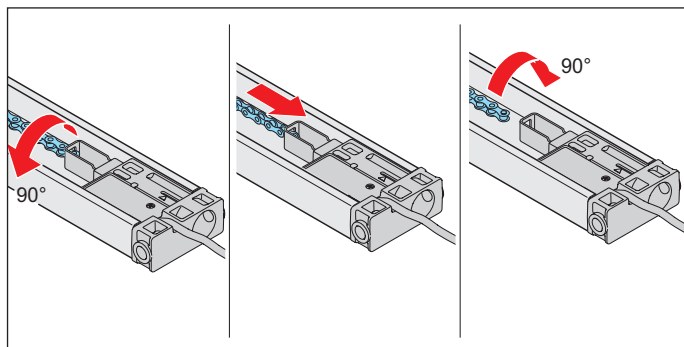

Fig. 5

5. Rotate the chain 90° and insert it into the chain holder of the **plug-in unit with control cable**.
Rotate the chain back 90°.

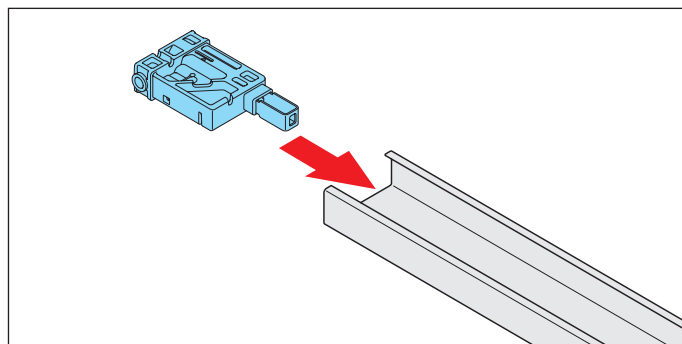

Fig. 6

6. Plug the plug-in unit without control cable in on the opposite side of the track.

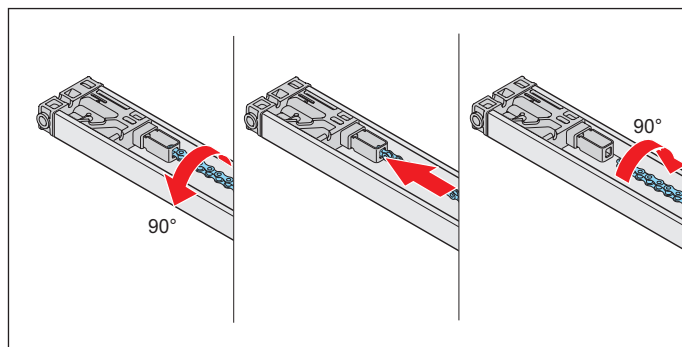

Fig. 7

NOTE

- The chain must be parallel to the track to prevent damage to the operator.

7. Rotate the chain 90° and insert it into the chain holder of the **plug-in unit without control cable**.
Rotate the chain back 90°.
⇒ The entire chain is attached.

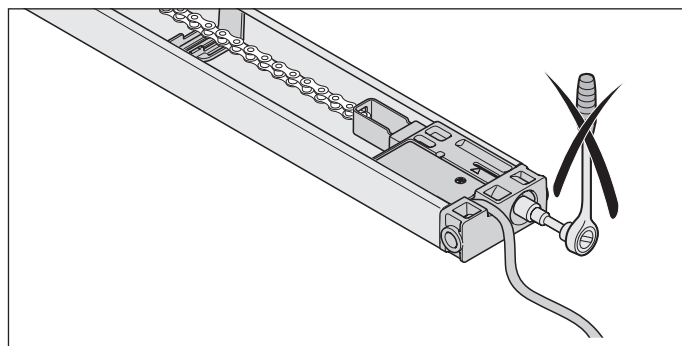

Fig. Plug-in unit with control cable

NOTE

- The plug-in unit with control cable must not be tensioned.

6. Installation

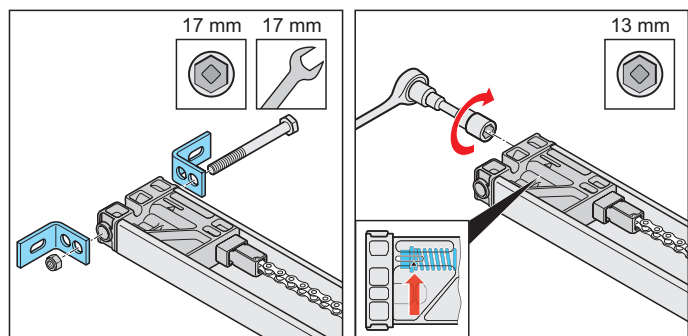

Fig. 8

Fig. 9

8. Tension the chain to the mark on the **plug-in unit without control cable**, see **arrow** in the detailed view.

9. Fasten the two header brackets to the **plug-in unit without control cable** with screw and nut.

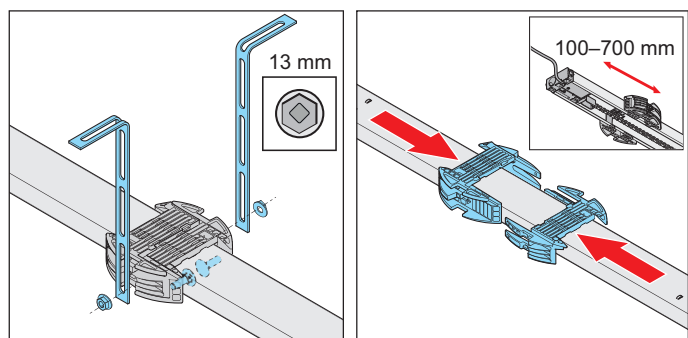

Fig. 10

Fig. 11

10. Turn the track to install the ceiling bracket.
The distance between the rear **plug-in unit with control cable** and the ceiling holder should be 100-700 mm.
Place the ceiling holder on the track and slide into one another.

NOTE

• Depending on the door construction, the installation situation and the installation type, it should be checked whether a second ceiling suspension unit is necessary.

11. Fasten the perforated strips to the ceiling holder on the left and right. Also observe the distances for installation to the ceiling or lintel.

⇒ The track is prepared for the remainder of the installation.

For further installation, see Chapter "6.6 Installation on the door".

6.5 Installing installation variant C of the drive system

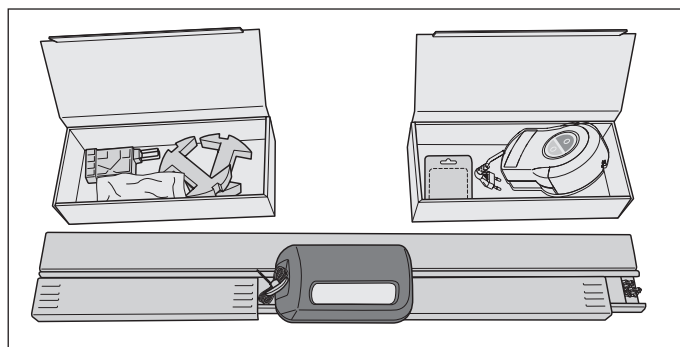

Fig. 1

⚠ CAUTION! Risk of injury to hands

Rough metal parts may cause abrasions and cuts when picked up or touched.

► You must wear safety gloves when working with rough metal parts.

1. Open the package.
Place the two cartons in the package beside the tracks and open them.
Check the entire contents against the scope of delivery listed in this Installation and Operating Manual; see Chapter "3.5 Scope of delivery."

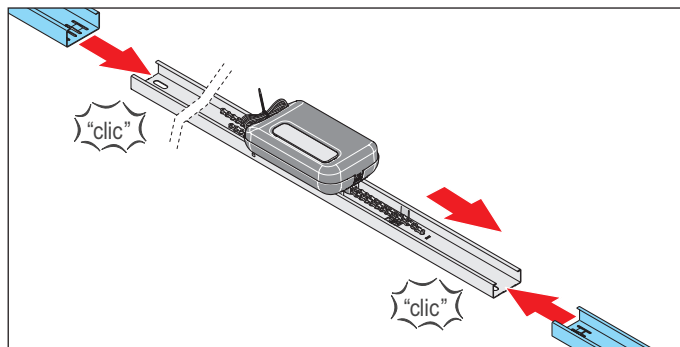

Fig. 2

2. Remove the two connecting sleeves beside the motor carriage and attach to the track on the left and right.

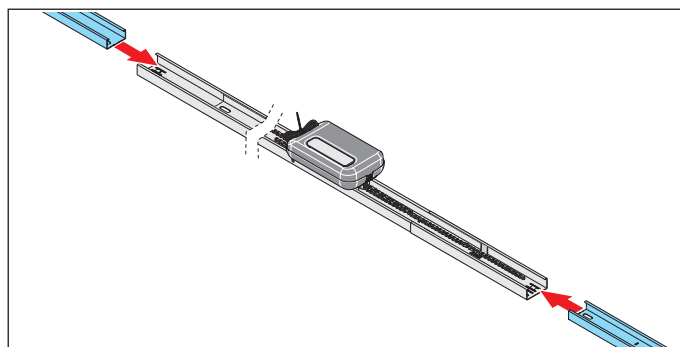

Fig. 3

3. Attach a track to each of the connecting sleeves.

6. Installation

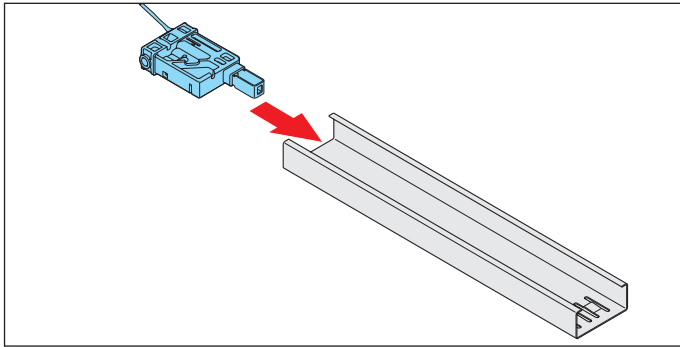

Fig. 4

4. Plug the **plug-in unit with control cable** into the track behind the limit stop.

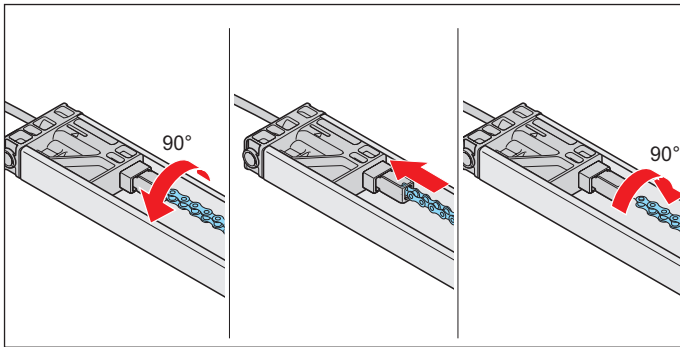

Fig. 5

➔ **NOTE**

- The chain must be parallel to the track to prevent damage to the operator.

5. Rotate the chain 90° and insert it into the chain holder of the **plug-in unit with control cable**. Rotate the chain back 90°.

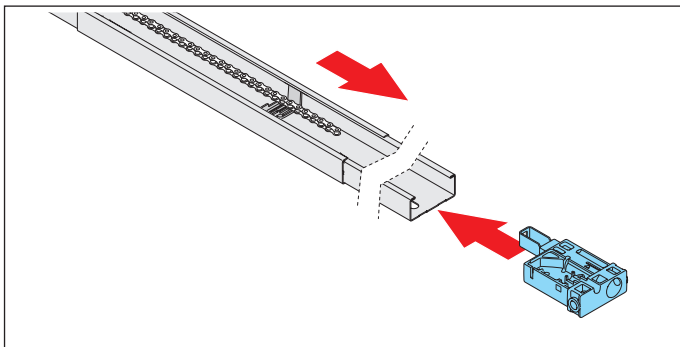

Fig. 6

6. Plug the **plug-in unit without control cable** in on the opposite side of the track. Lay the end of the chain over the limit stop.

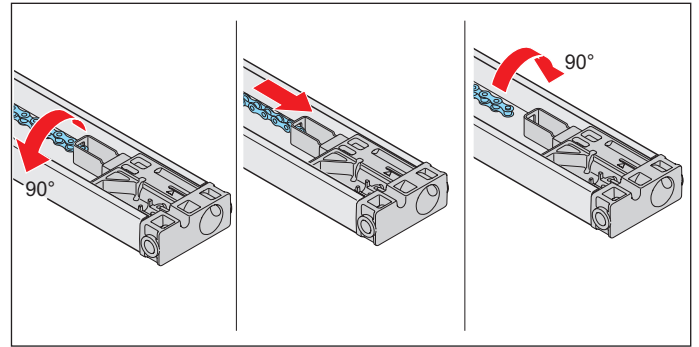

Fig. 7

7. Rotate the chain 90° and insert it into the chain holder of the **plug-in unit with control cable**. Rotate the chain back 90°.
➔ The entire chain is attached.

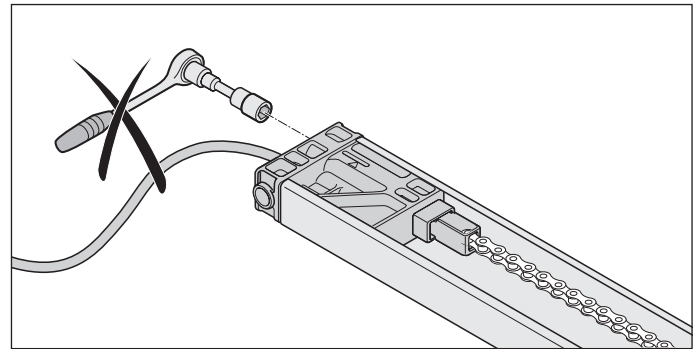

Fig. Plug-in unit with control cable

➔ **NOTE**

- The plug-in unit with control cable must not be tensioned.

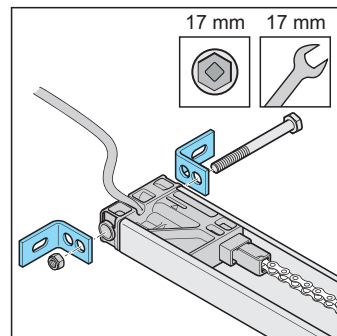

Fig. 8

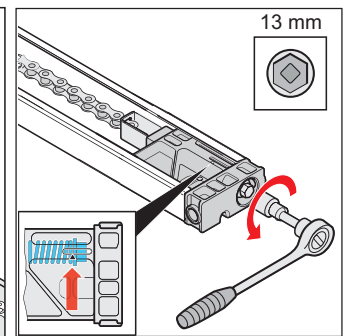

Fig. 9

8. Tension the chain to the mark on the **plug-in unit without control cable**, see **arrow** in the detailed view.
9. Fasten the two header brackets to the **plug-in unit with control cable** with screw and nut.

6. Installation

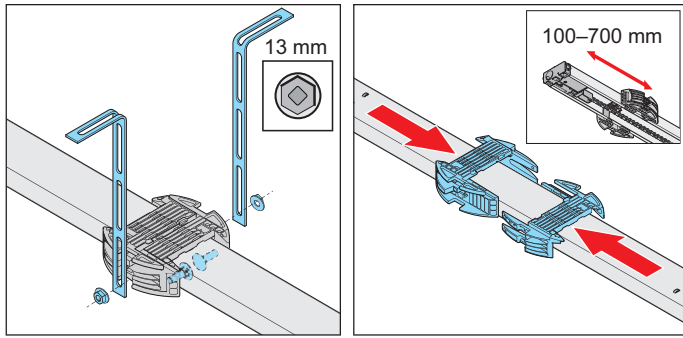

Fig. 10

Fig. 11

10. Turn the track to install the ceiling bracket.

The distance between the rear **plug-in unit without control cable** and the ceiling holder should be 100-700 mm.

Place the ceiling holder on the track and slide into one another.

NOTE

- Depending on the door construction, the installation situation and the installation type, it should be checked whether a second ceiling suspension unit is necessary.

11. Fasten the perforated strips to the ceiling holder on the left and right. Also observe the distances for installation to the ceiling or lintel.

⇒ The track is prepared for the remainder of the installation.

For further installation, see Chapter "6.6 Installation on the door".

6.6 Installation on the door

As installation on the door is similar for variants A, B and C, installation on the door is only described for variants A and B.

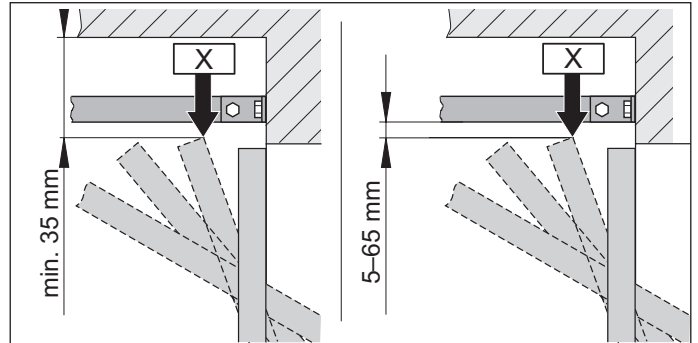

Fig. 1.1 Highest running point for one piece and up-and-over doors

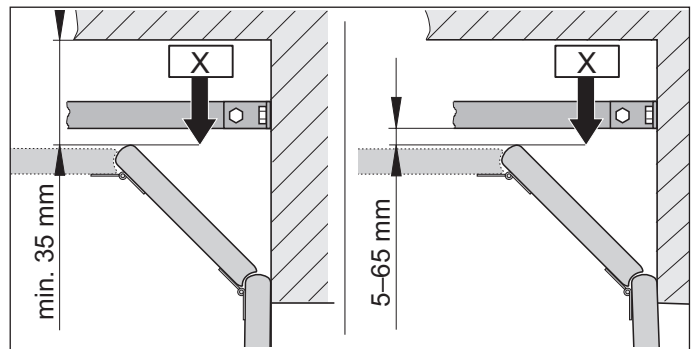

Fig. 1.2 Highest running point for a sectional door



INFORMATION

- The distance may be reduced if a door handle is attached to the middle of the door. The door must be able to run freely.

1. Measure the highest running point of the door "X" depending on the door type:
Open the door and measure the closest distance (min. 35 mm) between the top edge of the door and the ceiling.
The distance between "X" and the bottom edge of the track must be at least 5 mm and no more than 65 mm.
If the distance between the ceiling and the bottom edge of the track is greater than 245 mm, extend the ceiling holder with additional perforated strips.

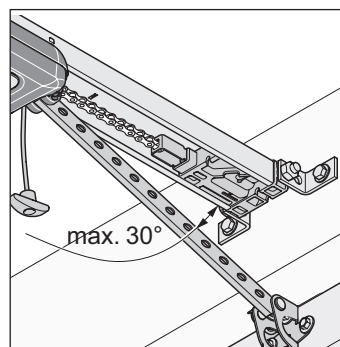

Fig. 2

6. Installation

2. The push arm must be at a max. angle of 30° with the door closed.

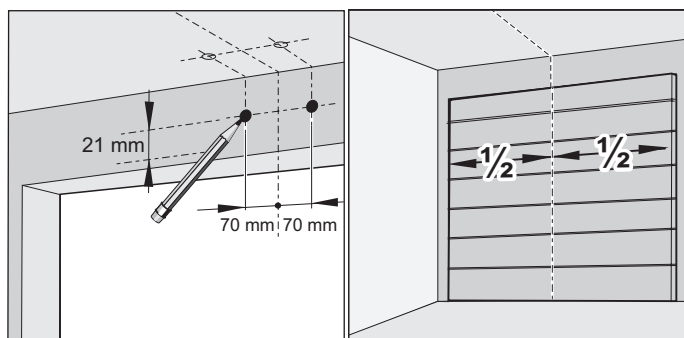

Fig. 3

Fig. 4

3. Close the door.
Select the lintel or ceiling for installation. Measure the centre of the door at the front and mark the position on the door and the lintel or ceiling.
4. Mark points 70 mm to the right and left of the centre of the door at the same height on the lintel or ceiling.

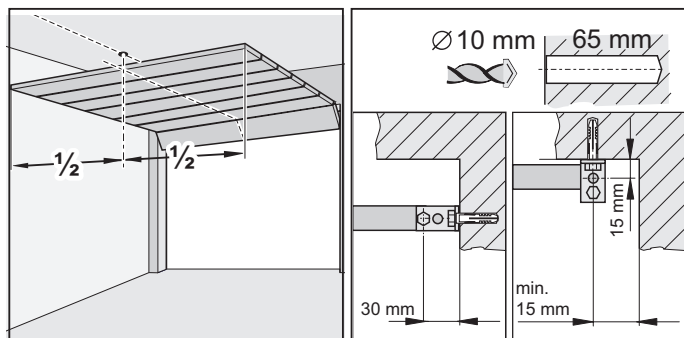

Fig. 5

Fig. 6

NOTE

- Cover the operator during drilling to prevent dirt from entering the operator unit and damaging it.

INFORMATION

- If installing on the ceiling, use drill holes 15 mm apart if possible. This reduces the tilting angle of the mounting bracket.
 - The drilling depth must be considered with respect to the ceiling and wall thickness, particularly with prefabricated garages. It may be necessary to reduce the hole depth.
 - Only use permissible mounting materials appropriate for the supporting surface.
5. Drill two holes (Ø 10 x 65 mm deep) in the ceiling or lintel.
6. Open the door.
Transfer the mark from the centre of the door to the ceiling at the rear.

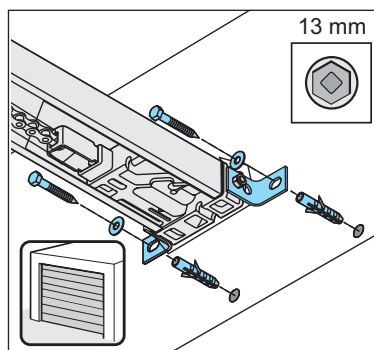

Fig. 7

7. Close the door.

Insert the wall plug into the lintel or ceiling. Lift the track at the front.

Screw the lintel fitting at the front to the lintel or ceiling with two screws and the washers. Tighten the screws.

⇒ The track is attached to the lintel or ceiling.

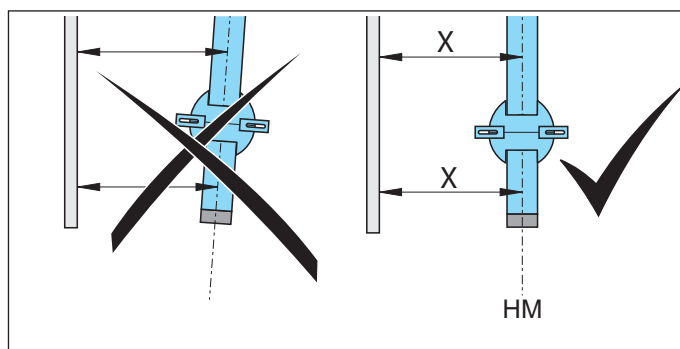

Fig. 8

NOTE

- The operator must always be installed parallel to the tracks of the door to prevent damage to the operator and the tracks.

8. Align the operator parallel to the tracks of the door.

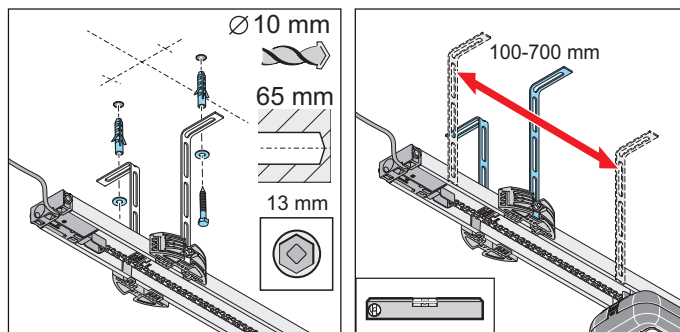

Fig. 9

Fig. 10

9. Align the track parallel to centre of the door at the rear. Align the ceiling bracket.

The distance between the rear plug-in unit and the ceiling holder should be approx. 100-700 mm. The ceiling bracket should be installed in this area.

6. Installation

Check the alignment of the track with a spirit level if necessary.

10. Mark the holes for the ceiling holder on the ceiling. Drill two holes (Ø 10 x 65 mm deep). Insert the wall plugs. Insert two screws with washers and screw to the ceiling with the perforated strips. Tighten the screws. ⇒ The track is attached to the ceiling.

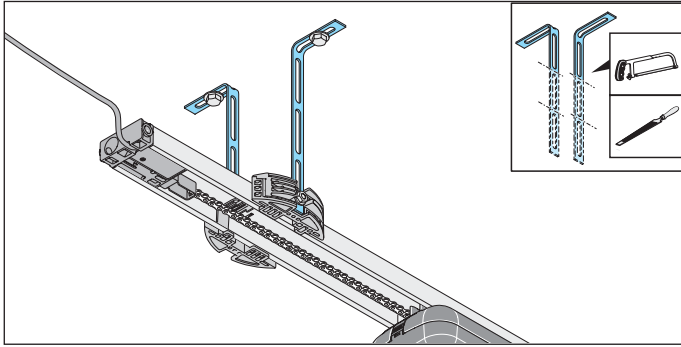

Fig. 11

⚠ CAUTION! Risk of injury to hands

Rough metal parts may cause abrasions and cuts when picked up or touched.

- ▶ The projecting perforated strips must be sawn off and deburred to prevent injury.
- ▶ Wear safety gloves when deburring.

11. The projecting perforated strips must be shortened.

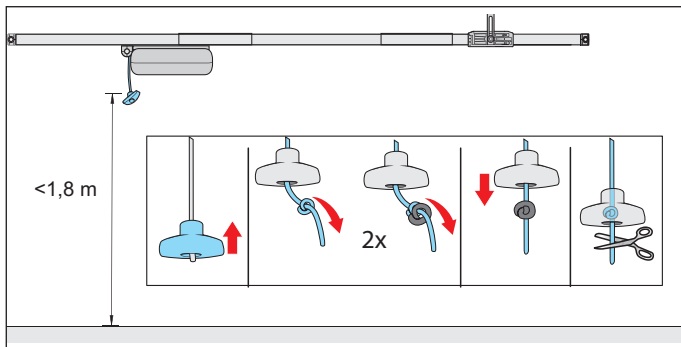

Fig. 12

⚠ WARNING! Danger of entrapment

Persons or animals in the movement area of the door may be trapped in a loop of the emergency release cord and the door may be accidentally unlocked. Severe injuries or death may result.

- ▶ The emergency release handle which is included must be used.

➔ NOTE

- The emergency release handle may cause damage, e.g. scratches on the vehicle. The distance between the garage floor and the emergency release cord must be less than 1.8 m. The emergency release handle must be at least 50 mm from moving and fixed parts throughout its complete travel path.

12. Attach the emergency release handle: Pull the cord through the emergency release handle. Tie a double knot in the cord at an appropriate point. Pull the emergency release handle over the double knot. If necessary, shorten the cord or lengthen it with suitable materials.

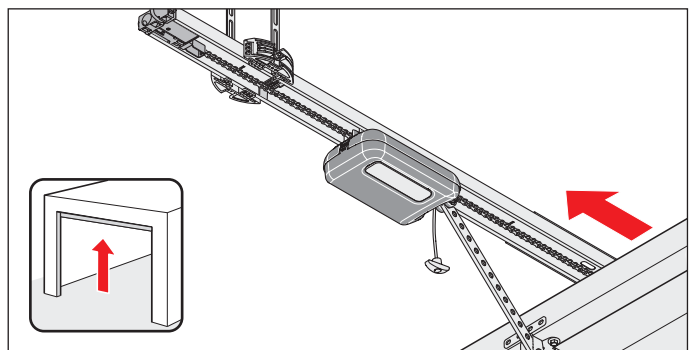

Fig. 13

13. Pull the emergency release cord once to unlock the motor carriage. Slide the motor carriage forward to the door.

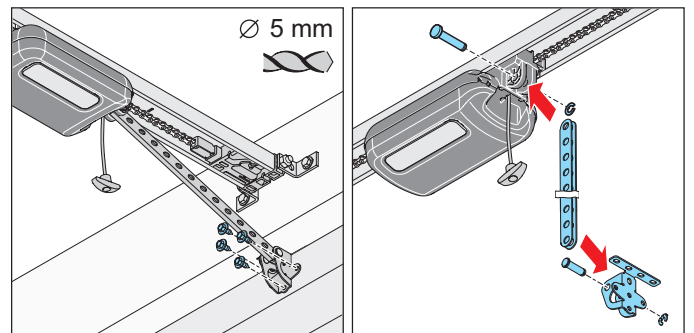

Fig. 14

Fig. 15

⚠ WARNING! Risk of injury in the head region

Impact with suspended objects may cause serious abrasions and cuts.

- ▶ You must wear a safety helmet when installing suspended parts.

14. Plug the push arm into the door bracket. Insert the bolt and slide on the safety bolt. Plug the push arm into the motor carriage at the front. Insert the bolt and slide on the safety bolt.
15. Align the door bracket with the centre of the door.

6. Installation

Mark the position of the holes and drill them (\varnothing 5 mm). Fix the door bracket to the door with the hexagon bolts.

⇒ The push arm is attached to the motor carriage and the door.

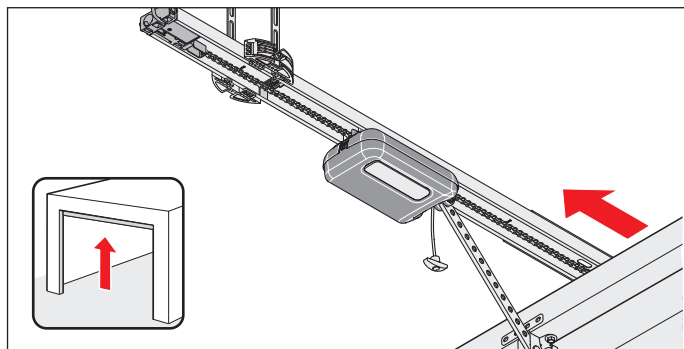

Fig. 16

NOTE

- The door must not rub against the operator or tracks. This could damage the operator or tracks. The operator must be offset.

16. Open the door completely by hand.

If the door rubs against the operator or the tracks, the operator must be offset.

⇒ The limit stop moves automatically with the motor carriage.

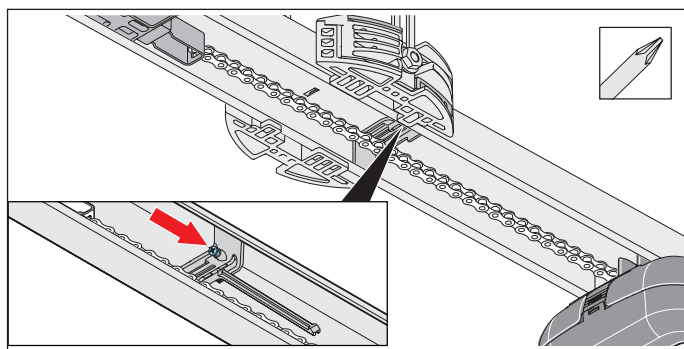

Fig. 17

NOTE

- Do not push the door all the way to the mechanical stop. This is because otherwise, the operator will pull the door against the mechanical stop. This will apply tension to the door and it may be damaged. A clearance of about 30 mm is required.

INFORMATION

- The limit stop can be subsequently pushed under the chain and screwed into the track. Then screw the limit stop tightly to the track at the respective spot.

17. Tighten the screw on the limit stop with a Phillips screwdriver without changing its position.

Check the door OPEN end position:

Open the door fully for this. The motor carriage moves against the limit stop to the door OPEN end position until a click noise is heard.

⇒ The door OPEN end position is set.

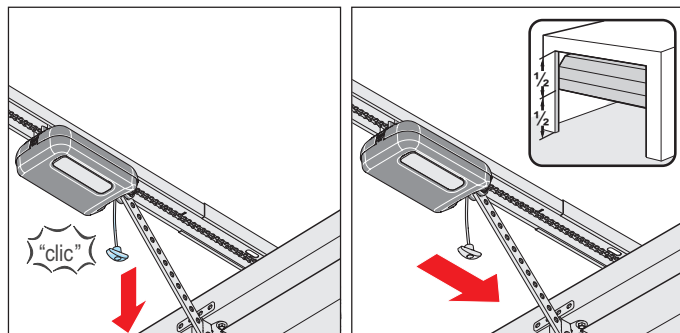

Fig. 18

Fig. 19

18. Move door to centre position.

⇒ The motor carriage moves with it.

19. Pull the emergency release cord.

⇒ **The motor carriage is locked.**

⇒ The door can only be moved by the operator.

20. Check to make sure that no part of the door projects into public footpaths or roads.

⚠ WARNING! Danger due to projecting parts

Parts must not project into public roads or footpaths. This also applies while the door is moving. Persons and animals may be seriously injured.

- ▶ Keep public roads and footpaths clear of projecting parts.

⇒ **Installation of the operator is complete.**

6. Installation

6.7 Installing the wall control unit

In particular, observe the basic warnings below.

DANGER



Danger due to electric current!

Contact with live parts may result in electric current flowing through the body. Electric shock, burns or death will result.

- ▶ All work on electrical components must be carried out by a **trained electrician**.
- ▶ Before inserting the mains power plug for the first time, ensure that the voltage of the power source matches the voltage listed on the operator type plate.
- ▶ Do not connect the power supply until installation is complete.
- ▶ Disconnect the mains plug before working on the operator.
- ▶ If an accumulator is connected, disconnect it from the control unit.
- ▶ Check that the operator is not live.
- ▶ Secure the operator against being switched back on.

WARNING



Danger of crushing and shearing!

The door can be actuated via the wall switch. If the door moves and there are persons or animals in the movement area, crushing and shearing injuries may be caused by the mechanism and safety edges of the door.

- ▶ The wall control unit with keypad must be mounted within sight of the door.
- ▶ The wall control unit must not be installed in the direct vicinity of moving parts.
- ▶ The membrane keypad of the wall control unit must be installed at a height of at least 1.5 m.

NOTE

- To prevent damage to the operator, do not connect the wall control unit to the power supply until installation is complete.



INFORMATION

- The power cord that has been provided may not be shortened or extended. All devices to be connected externally must have safe isolation of the contacts from the mains voltage supply in accordance with IEC 60364-4-41. Wiring for external devices must be installed in accordance with IEC 60364-4-41. All electrical wiring must be firmly secured to prevent displacement.

The following must be observed when installing the wall control unit:

- The power cable is approx. 1.2 m long.
- Note that the distance between the wall control unit and the power outlet must not exceed 1.1 m.
- The maximum length of the control cable is 5 m, and it must not be extended.
- The membrane keypad of the wall control unit must be installed at a height of at least 1.5 m.

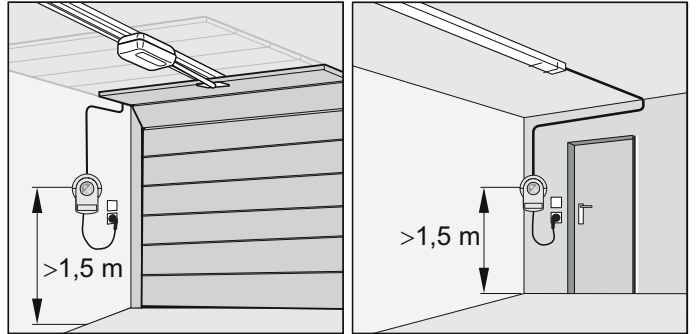

Fig.1



INFORMATION

- The drilling depth must be considered with respect to the ceiling and wall thickness, particularly with prefabricated garages. It may be necessary to reduce the hole depth. Only use permissible mounting materials appropriate for the supporting surface.

1. Choose a suitable location for the wall control unit close to an existing power outlet.

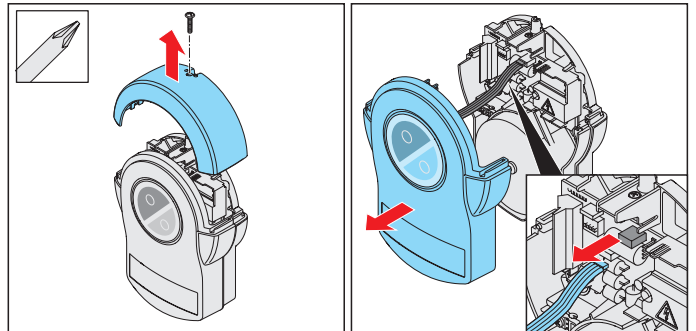

Fig. 2

Fig. 3

NOTE

- To prevent damage to the operator, do not connect the wall control unit to the power supply until installation is complete.
- The control unit cover is connected to the circuit board of the wall control unit via a connection cable.
- If an accumulator has been installed, it is also connected to the circuit board. Carefully remove the control unit cover and unplug the connections. This prevents damage to the wall control unit.

6. Installation

2. Loosen the screws on the wall unit of the light cover and remove the light cover upwards. Hold the front cover firmly while doing so.
3. Remove the control unit cover gently towards the front and unplug the connection cable for the membrane keypad from the wall control unit.

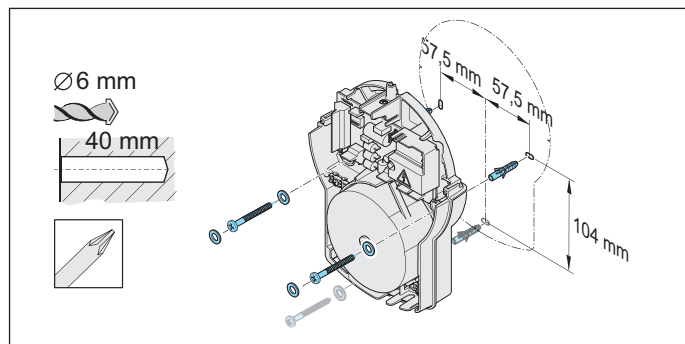

Fig. 4: Installation example

⚠ WARNING! Risk of eye injury!

Chips flying when drilling may cause serious injuries to eyes and hands.

▶ Wear safety glasses when drilling.

4. Transfer the mounting points to the substructure. Drill two holes (Ø 6 x 40 mm deep). Insert the two wall plugs. Affix the wall control unit with two screws and two washers, align the unit and firmly tighten the screws.
5. Route the control cable of the plug-in unit up to the wall control unit and secure to prevent displacement.

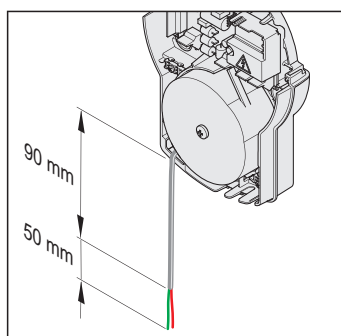

Fig. 6

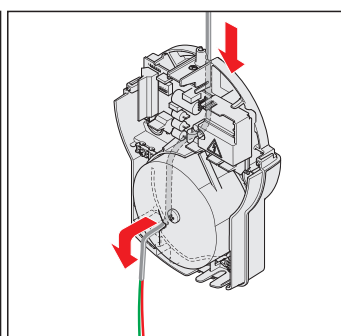

Fig. 7

6. Lay the control cable along the cable conduit on the rear side of the wall control unit up to the cable inlet. Feed the control cable into the wall control unit through the cable inlet.
7. Shorten the control cable to no less than 140 mm in length, uncover the last 50 mm and strip the wires.

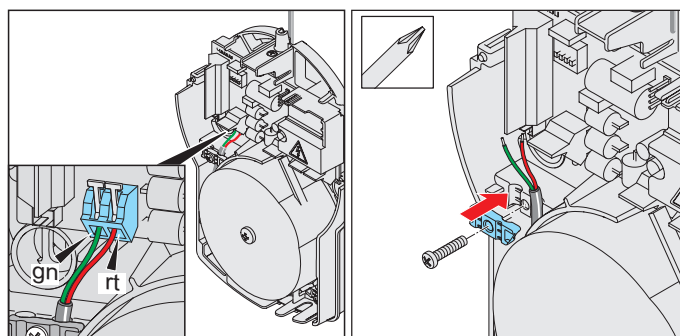

Fig. 8

Fig. 9

8. Route the control cable in the wall control unit along the transformer up to the **gn/rd** terminal. Secure the control cable with the upper strain relief to prevent displacement.
 9. Connect the **green** wire of the control cable to the **gn** terminal. Connect the **red** wire of the control cable to the **rd** terminal.
 10. Close the housing in reverse order
⇒ Installation of the wall control unit is complete.
- Other connection options such as buttons or warning light are described in Chapter "**11. Connections and special functions of the wall control unit**".

7. Removing and fastening covers

7.1 Cover of the motor carriage

In particular, observe the warnings below.

WARNING



Danger due to optical radiation!

Looking into an LED at short range for an extended period may cause optical glare. This may temporarily reduce vision. This may cause serious or fatal accidents.

▶ Never look directly into an LED.

WARNING



Danger due to hot surfaces!

After frequent operation, parts of the motor carriage or the control unit may become hot. If the cover is removed and hot parts are touched, they may cause burns.

▶ Allow the operator to cool down before removing the cover.

Removing the cover

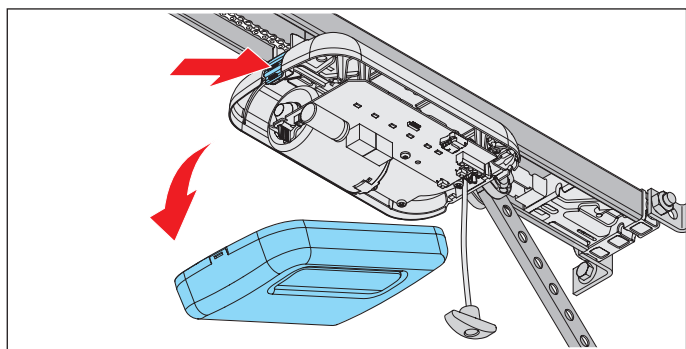

Fig. 1

1. Press on the cover lock at the back of the motor carriage and remove the cover.

Installing the cover

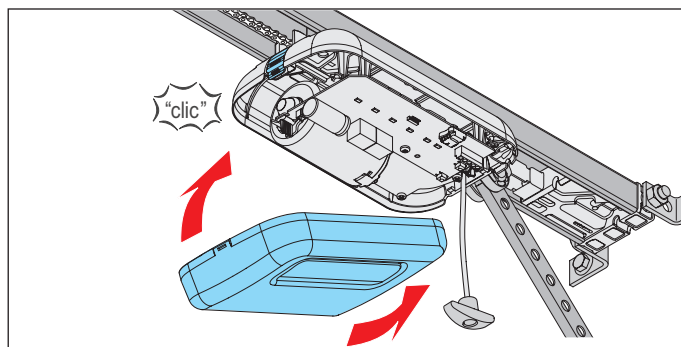

Fig. 1

1. Insert the cover from the front and lock it to the motor carriage at the back.

7. Removing and fastening covers

7.2 Light and control unit cover of the wall control unit

In particular, observe the warnings below.

DANGER



Danger due to electric current!

Contact with live parts may result in electric current flowing through the body. Electric shock, burns or death will result.

- ▶ All work on electrical components must be carried out by a **trained electrician**.
- ▶ Disconnect the mains plug before working on the operator.
- ▶ If an accumulator is connected, disconnect it from the control unit.
- ▶ Check that the operator is not live.
- ▶ Secure the operator against being switched back on.

WARNING



Danger due to hot surfaces!

After frequent operation, parts of the motor carriage or the control unit may become hot. If the cover is removed and hot parts are touched, they may cause burns.

- ▶ Allow the operator to cool down before removing the cover.

Removing the light and control unit cover

1. Disconnect the operator from the mains voltage. Check that the operator is disconnected from the power supply.

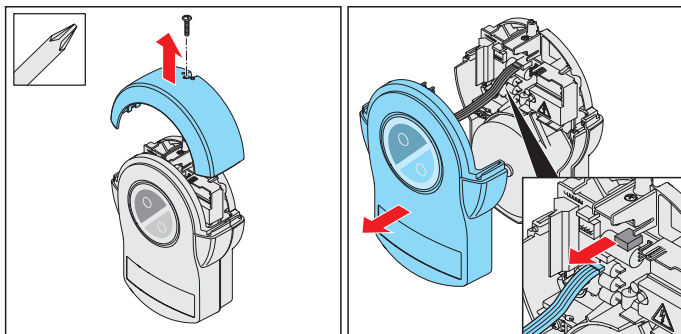

Fig. 2

Fig. 3

2. Unscrew the light cover from the wall control unit and remove it upwards. Hold the front cover firmly while doing so.

NOTE

- If there is an accumulator in the cover of the ceiling control unit, remove the cover carefully. The accumulator is loose in the cover. Disconnect the accumulator plug from the circuit board.

3. Remove the control unit cover gently towards the front and unplug the connection cable for the membrane keypad from the wall control unit.
4. If an accumulator is used, it must also be disconnected, see chapter "11.11 Installing and removing the accumulator".
5. Remove the control unit cover.

Attaching the light and control unit cover

1. After working on the wall control unit, replace the cover in reverse order.
2. Connect the operator to the mains voltage. Check that the power supply is connected.
⇒ The operator is supplied with mains voltage.

8. Electrical connection

8.1 Connection to a power outlet

A power outlet is required for the electrical connection of the operator.

A power outlet must be installed by a **trained electrician**. The power outlet must be protected by a fuse. Local and national installation regulations (e.g. VDE) must be observed.

In particular, observe the warnings below.

WARNING



Danger due to electric current!

Contact with live parts may result in electric current flowing through the body. Electric shock, burns or death will result.

- ▶ All work on electrical components must be carried out by a **trained electrician**.
- ▶ Before inserting the mains power plug for the first time, ensure that the voltage of the power source matches the voltage listed on the operator type plate.
- ▶ Do not connect the power supply until installation is complete.
- ▶ Disconnect the mains plug before working on the operator.
- ▶ If an accumulator is connected, disconnect it from the control unit.
- ▶ Check that the operator is not live.
- ▶ Secure the operator against being switched back on.

NOTE

- To prevent damage to the operator, do not connect the wall control unit to the power supply until installation is complete.

INFORMATION

All devices to be connected externally must have safe isolation of the contacts from the mains voltage supply in accordance with IEC 60364-4-41.

Wiring for external devices must be installed in accordance with IEC 60364-4-41.

All electrical wiring must be firmly secured to prevent displacement.

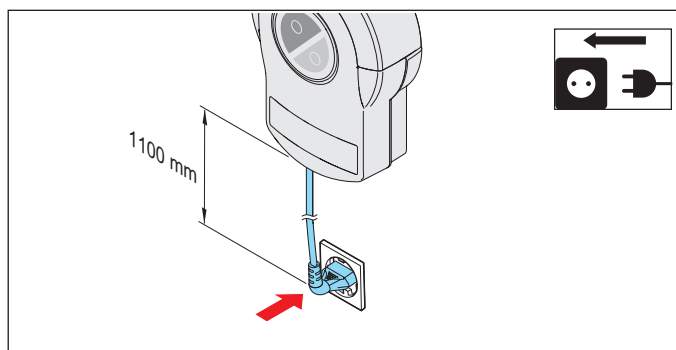

Fig. Distance between wall control unit and power outlet
The power cord is approx. 1.2 m long. The power cord supplied must not be shortened or extended. Note that the distance between the wall control unit and the power outlet must not exceed 1.1 m.

The power outlet must be installed as follows:

- within easy reach of the wall control unit power cable
- easily visible and clear of obstacles

9. Initial operation

9.1 Important notes and information

In particular, observe the warnings below.

WARNING



Danger of entrapment!

If the force setting is too high, persons or animals in the movement area of the door may be trapped and pulled along with the door. Severe injuries or death may result.

- ▶ The force setting is relevant to safety and must be carried out by a **qualified specialist**.
- ▶ You must proceed with extreme caution if you check and if necessary adjust the force setting.
- ▶ Please note that the operator may only be operated if a non-hazardous force value has been set.
- ▶ Select the force setting low enough to eliminate any danger of injury by the closing force.



Danger of crushing and shearing!

If the door moves and there are persons or animals in the movement area, crushing and shearing injuries may be caused by the mechanism and safety edges of the door.

- ▶ Only use the operator when you have a direct view of the door.
- ▶ All danger zones must be visible during the entire door operation.
- ▶ Always keep the moving door in sight.
- ▶ Keep persons and animals clear of the range of movement of the door.
- ▶ Never put your hand near the door when it is moving or near moving parts. In particular, do not reach into the moving push arm.
- ▶ Do not reach into the ceiling suspension unit when the motor carriage is running along the track.
- ▶ Do not drive through the door until it has opened completely.
- ▶ Never stand under the opened door.



Danger due to optical radiation!

Looking into an LED at short range for an extended period may cause optical glare. This may temporarily reduce vision. This may cause serious or fatal accidents.

- ▶ Never look directly into an LED.

NOTE

- In the case of a door without a fixed lintel, programming of the door CLOSE end position should be carried out as described in Chapter "9.3 Carrying out manual initial operation". Otherwise, the operator may be damaged.

- Do not use a metal object to set the DIP switches, because this may damage the DIP switches or the circuit board.
Use a suitable tool to set the DIP switches, such as a flat, thin plastic object.

- Objects in the movement area of the door may be jammed and damaged.
Objects must not be in the range of movement of the door.

INFORMATION

- The control unit detects a short-circuit between chain and track and then switches the operator off.
- If a photocell is used, it must not be actuated when starting the programming.
If a photocell is used as a frame photocell, move the door to the centre position.

9.2 Carrying out automatic initial operation

Before initial operation, read this chapter with special care to ensure that you can make the adjustments to the operator safely and optimally.

WARNING



Danger of entrapment!

If the force setting is too high, persons or animals in the movement area of the door may be trapped and pulled along with the door. Severe injuries or death may result.

- ▶ The force setting is relevant to safety and must be carried out by a **qualified specialist**.
- ▶ You must proceed with extreme caution if you check and if necessary adjust the force setting.
- ▶ Please note that the operator may only be operated if a non-hazardous force value has been set.
- ▶ Select the force setting low enough to eliminate any danger of injury by the closing force.

INFORMATION

- During initial operation:
 - Stay in the garage, particularly when programming.
 - Obstacle recognition is not yet coordinated to the door and is in the programming phase.
- Programming can be carried out via a handheld transmitter or an external button.
- The limit stop can also be retrofitted.

9. Initial operation

For compliance with EN 13241-1, before initial operation, the door type must be selected and set on the motor carriage with the DIP switch.

The factory setting of the DIP switches on the motor carriage is "OFF," which is then applicable for sectional doors. The motor carriage has an automatic force setting. The motor carriage memorises the required force during the door OPEN and CLOSE movements and stores it when the end position has been reached.

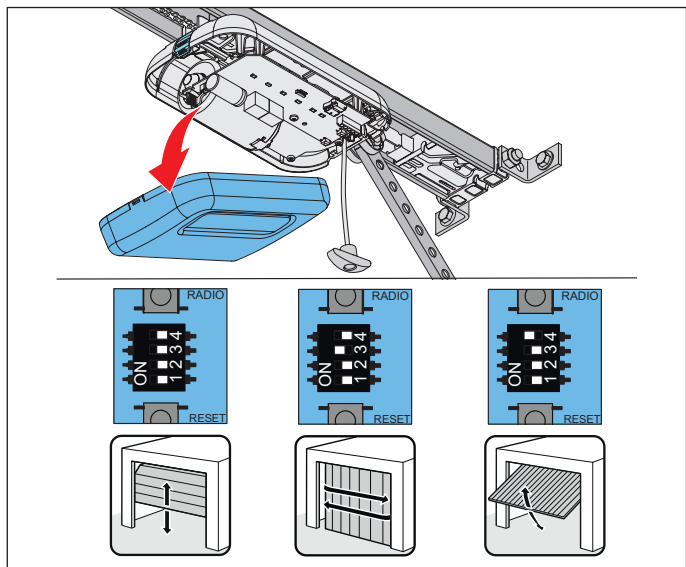

Fig. 1

1. Open the cover of the motor carriage. Set the DIP switches on the motor carriage depending on the door.

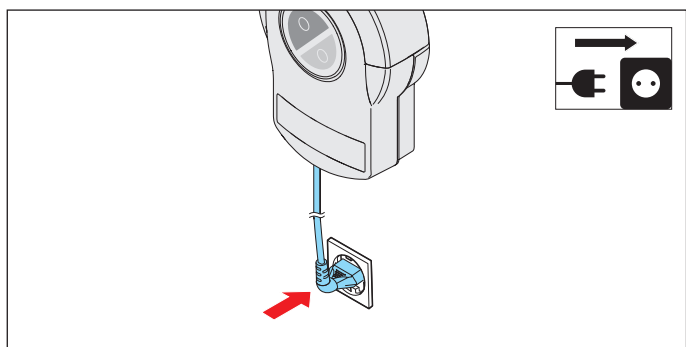

Fig. 2

2. Compare the existing power supply with the type plate. Connect the operator with the mains voltage.

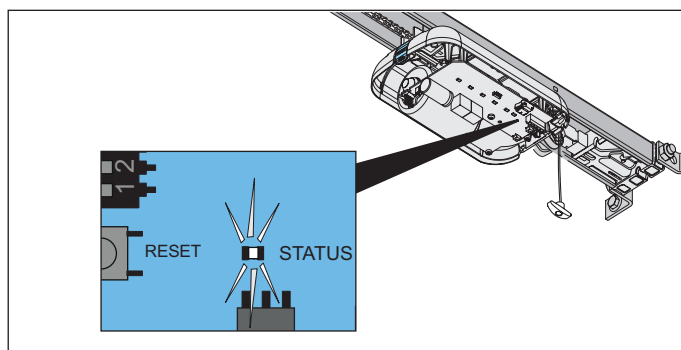

Fig. 2.1

⇒ The status LED of the motor carriage flashes green.

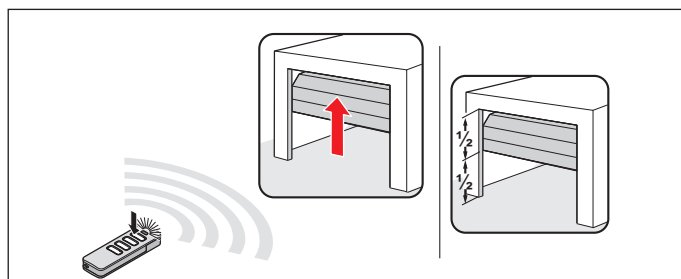

Fig. 3

3. After the operator has been connected to the voltage supply, its first movement after a pulse is always door OPEN.

Briefly press button 1 on the preprogrammed handheld transmitter. See also the separate instructions for the "**Handheld transmitter**".

⇒ The motor carriage moves slowly to the door OPEN end position and **automatically** switches off at the limit stop.

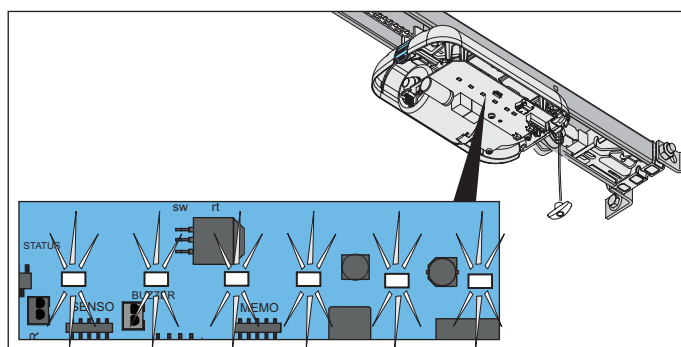

Fig. 3.1

⇒ The operator lighting flashes.

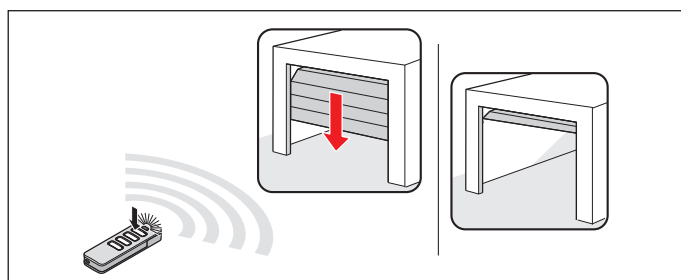

Fig. 4

9. Initial operation

- Press button 1 on the handheld transmitter again **briefly**.
 - ⇒ The motor carriage moves slowly in the door CLOSE direction.
 - ⇒ The operator lighting flashes.
The motor carriage switches off **automatically** when it reaches the factory-set closing force at the door CLOSE end position.
 - ⇒ The operator lighting flashes in a different sequence.

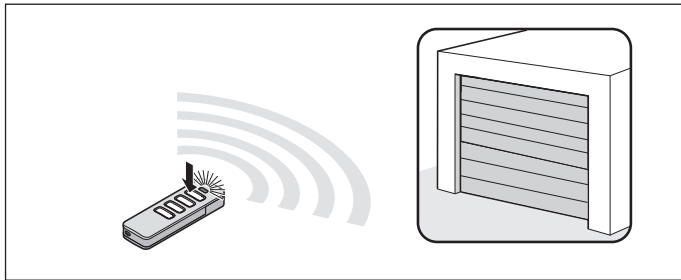

Fig. 5

- Press button 1 on the handheld transmitter **briefly** (<1 second) to save the end position.
 - ⇒ The operator lighting flashes briefly in a fast sequence.

The operator automatically starts its programming process

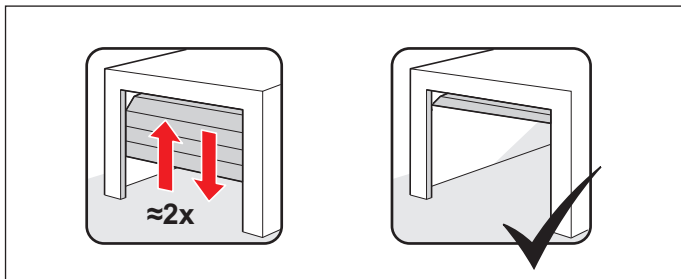

Fig. 5.1

- ⇒ The motor carriage moves **automatically** to the door OPEN end position again and programs the required operating force.
 - ⇒ The motor carriage **automatically** moves to the door CLOSE end position.
If necessary, the motor carriage moves over the path several times for programming with a greater door weight.
 - ⇒ The motor carriage **automatically** moves briefly in the door OPEN direction to program the soft run.
 - ⇒ The door **automatically** returns to the door CLOSE end position.
 - ⇒ The motor carriage **automatically** moves to the door OPEN end position.
 - ⇒ The LEDs of the operator lighting remain **steady**.
- The function of the emergency release must be checked in the door CLOSE end position. Unlocking must be possible.
 - ⇒ **Operator is programmed and ready for use.**



INFORMATION

- The motor carriage stops if the door is difficult to move. The door mechanism must be checked; see Chapter "9.3 Carrying out manual initial operation".
- It may be necessary to adjust the end positions; see Chapter "9.5 Mechanical adjustment of the end positions".
- The force setting must be checked after installation of the operator; see Chapter "12.1 Testing obstacle detection".

9.3 Carrying out manual initial operation

In the case of doors without lintel or without lintel panel, programming should be carried out manually. To do this, carry out steps 1.–3. In Chapter "9.2 Carrying out automatic initial operation" and then the steps below:

- Press button 1 on the handheld transmitter **briefly**.
 - ⇒ The door begins to move towards the door CLOSE end position.
- Before the door reaches the door CLOSE end position, press button 1 on the handheld transmitter again **briefly**.
 - ⇒ The door stops.
- To approach the desired end position for door CLOSE, **press and hold** button 1 on the handheld transmitter until the motor carriage **moves briefly**. Release button 1 on the handheld transmitter.
- The process can be repeated until the desired end position is reached.
- Press button 1 on the handheld transmitter **briefly** (<1 second) to save the door CLOSE end position.
- The door then starts the programming process; see Chapter "9.2 Carrying out automatic initial operation", section "The operator automatically starts its programming process".

9.4 Detecting obstacles during the force programming run

If the door detects an obstacle during its first door CLOSE movement and the force programming runs cannot be completed, the door stops.



NOTE

- Check the movement range, mechanism, spring tension and the weight balance to prevent damage to the door system.
- Press and hold** button 1 on the handheld transmitter.
 - ⇒ The motor carriage **moves briefly** and then moves continuously in the door CLOSE direction until the **desired end position** has been reached.
 - Release button 1 on the handheld transmitter.
 - Fine adjustment:**
Press and hold button 1 on the transmitter until the motor carriage **jerks briefly**.

9. Initial operation

Release button 1 on the handheld transmitter.

- 3.1 The process can be repeated until the desired end position is reached.

Press button 1 on the handheld transmitter **briefly** (< 1 second) to save the door CLOSE end position.

- ⇒ The motor carriage starts the **automatic** force programming runs for the door OPEN end position.
- ⇒ The door starts the **automatic** force programming runs for the door CLOSE end position.

If an obstacle is detected again, the motor carriage stops and reverses a short distance.

1. **Press and hold** button 1 on the handheld transmitter.
 - ⇒ The motor carriage starts without jerking, because the end position of the door is already saved.
 - ⇒ The motor carriage moves to the end position.
2. Release button 1 on the handheld transmitter.
3. Press button 1 on the handheld transmitter **briefly**.
 - ⇒ **Automatic force programming runs start again.**
 - ⇒ On completion of the force programming runs, the motor carriage **automatically** moves to the door OPEN end position.
 - ⇒ The LEDs of the operator lighting remain **steady**.
4. The function of the emergency release **must** be checked in the door CLOSE end position. Unlocking must be possible.
 - ⇒ **Operator is programmed and ready for use.**

9.5 Mechanical adjustment of the end positions

Increasing the closing pressure of the end position for door CLOSE

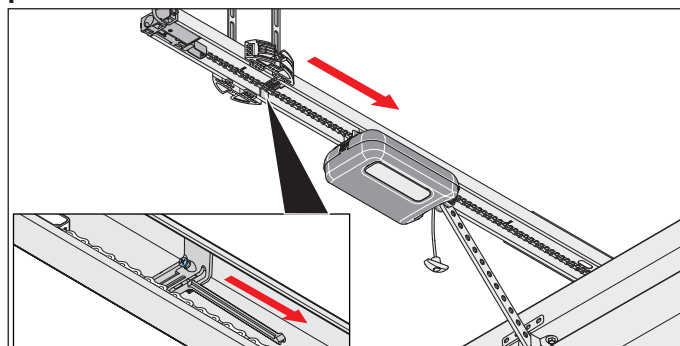

Fig. 1

1. Loosen the screw on the limit stop and move the limit stop a few millimetres towards door CLOSE. Re-tighten the screw.
2. The function of the emergency release must be checked in the door CLOSE end position. Unlocking **must** be possible.

Reducing the closing pressure of the end position for door CLOSE

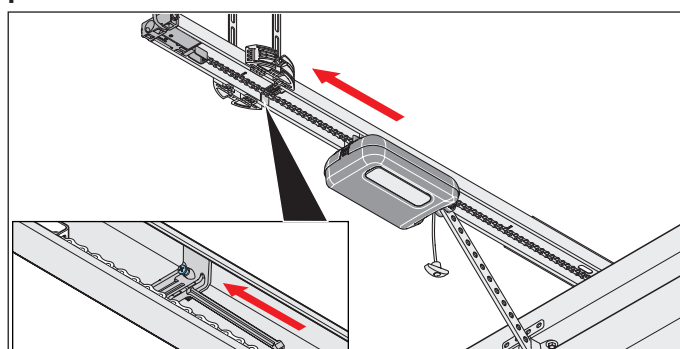

Fig. 1

1. Loosen the screw on the limit stop and move the limit stop a few millimetres towards door OPEN. Re-tighten the screw.

NOTE

- Do not push the door all the way to the mechanical stop. This is because otherwise, the operator will pull the door against the mechanical stop. This will apply tension to the door and it may be damaged. A clearance of about 30 mm is required.

9. Initial operation

9.6 Attaching information sign and warning signs

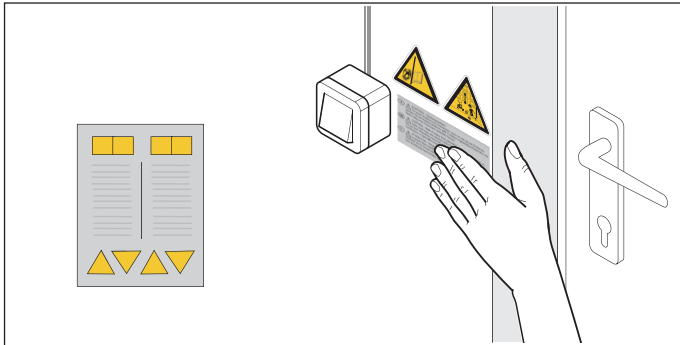

Fig. 1.1 Attach sticker near the stationary control or control unit



Fig. 1.2 Attach sticker on door panel

1. Attach the warning signs and information sign at a cleaned and degreased point:
 - far from moving parts
 - near the stationary control or control unit
 - at eye level in a highly visible section of the door leaf
2. Carry out obstacle detection, see Chapter "12.1 Testing obstacle detection".
 - ⇒ **Initial operation is complete.**

10. Connections and special functions of the motor carriage

10.1 Motor carriage circuit board

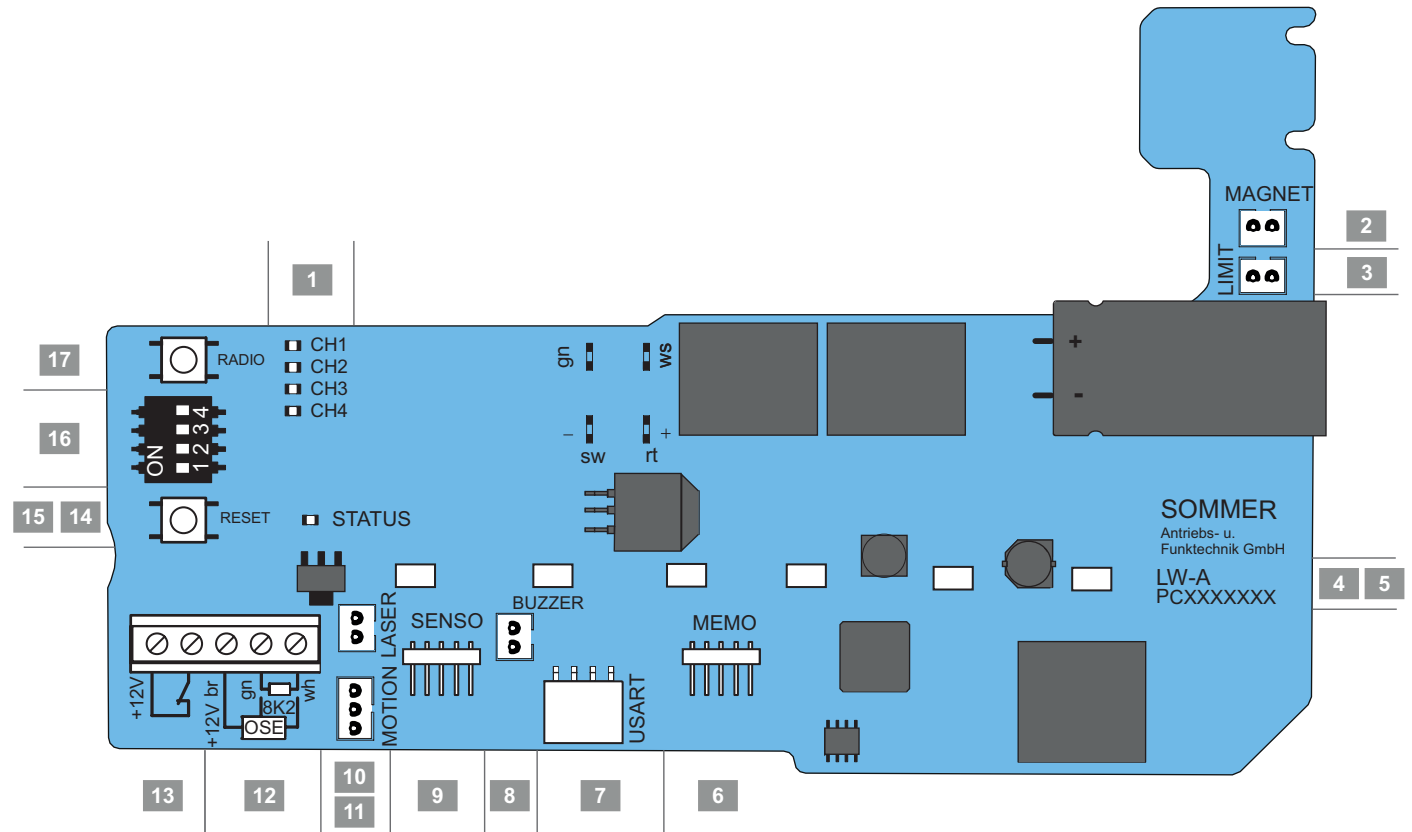

Fig. Motor carriage circuit board, (complete version)*

Connection options on the motor carriage



1	LED, CH 1–4, red Display for radio channel	10	LASER slot, white, 2-pin Parking position laser terminal
2	MAGNET slot, green, 2-pin Lock terminal	11	MOTION slot, white, 3-pin Terminal for movement sensor
3	LIMIT slot, blue, 2-pin Limit switch terminal (OPEN)	12	Terminal for safety contact strip 8k2/OSE
4	Circuit board label	13	Terminal for wicket door safety device, potential-free
5	LEDs, operator lighting	12/13	Terminal DC 12 V, max. 100 mA
6	MEMO slot Memo terminal	14	Status LED, green
7	USART slot Interface	15	Reset button, green
8	BUZZER slot, black, 2-pin Warning or alarm buzzer terminal	16	DIP switches
9	SENSO slot Senso terminal	17	Radio button, red

* The version can vary depending on the type. This means the use of accessories can vary.

A connection diagram can be found in Chapter "18. Connection diagrams and functions of the DIP switches pro/pro+"

10. Connections and special functions of the motor carriage

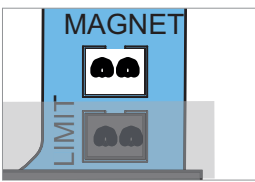
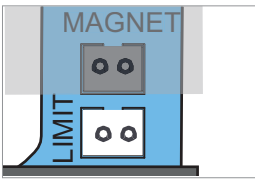
10.2 Connection options on the motor carriage

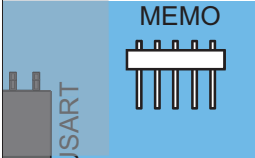
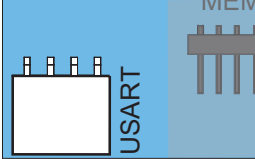
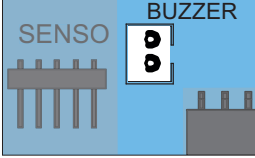
Circuit board section	Function/ application example
1 Radio channels, CH 1–4, red 	
2 MAGNET slot*, green, 2-pin 	Lock terminal Locking magnet
3 Limit slot, blue, 2-pin 	
4 Circuit board label	
5 Operator lighting, 6 LEDs 	
6 MEMO slot* 	Memo terminal Memory extension for 450 transmitter commands
7 USART slot 	Terminal, e.g. for Home automation
8 BUZZER slot*, black, 2-pin 	Warning or alarm buzzer terminal

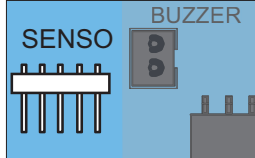
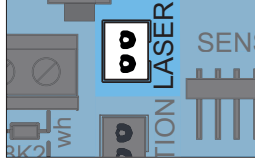
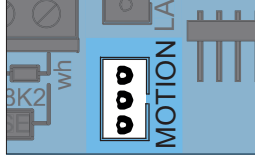
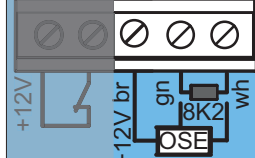
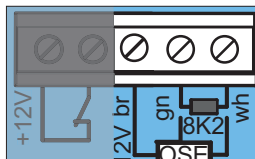
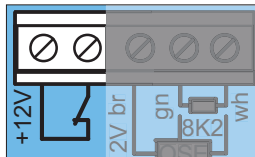
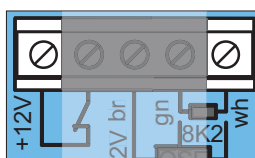
Circuit board section	Function/ application example
9 SENS0 slot* 	Sens0 terminal Humidity sensor
10 LASER slot*, white, 2-pin 	Parking position laser terminal
11 MOTION slot*, white, 3-pin 	Terminal for movement sensor 3-pin
12.1 8k2* terminal 	
12.2 OSE* connection 	+ 12 V = br OSE = gn GND = wh
13 Wicket door safety device terminal* 	(wicket door switch, reed contact etc.) potential-free Contact command (12 V DC, 10 mA) normally closed contact
12/13 Output DC +12 V terminal* 	max. 100 mA +12 V GND = wh Power supply for optional accessories, option of finger scanner or external lighting

10. Connections and special functions of the motor carriage

Circuit board section Function/
application example

14 Status LED, green

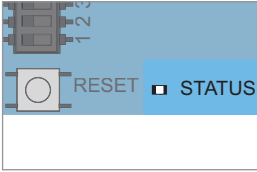

15 Reset button, green



16 DIP switches

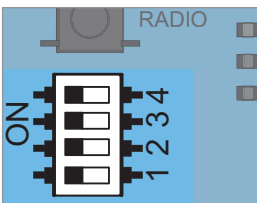

17 Radio button, red

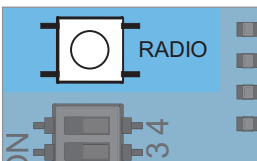

* The version can vary depending on the type. This means the use of accessories can vary.

⚠ DANGER



Danger due to electric current!

Contact with live parts may result in electric current flowing through the body. Electric shock, burns or death will result.

- ▶ All work on electrical components must be carried out by a **trained electrician**.
- ▶ Do not connect accessories unless the operator is disconnected from the power supply.
- ▶ Disconnect the mains plug before working on the operator.
- ▶ If an accumulator is connected, disconnect it from the control unit.
- ▶ Check that the operator is not live.
- ▶ Secure the operator against being switched back on.

➔ NOTE

- Do not use a metal object to set the DIP switches, because this may damage the DIP switches or the circuit board.
Use a suitable tool to set the DIP switches, such as a flat, thin plastic object.

10.3 Reducing the illumination power of LEDs

⚠ WARNING



Danger due to optical radiation!

Looking into an LED at short range for an extended period may cause optical glare. This may temporarily reduce vision. This may cause serious or fatal accidents.

- ▶ Never look directly into an LED.

The illumination power of the LEDs of the operator lighting can be reduced during adjustment work on the motor carriage.

1. Press the Radio or Reset button once briefly.
⇒ Illumination power of LEDs reduced.

10.4 Explanation of the radio channels

LED	Radio channel	Setting/function
1	CH 1	Pulse mode
2	CH 2	Partial opening or lighting function
3	CH 3	Defined OPEN
4	CH 4	Defined CLOSE

10.5 Programming the transmitter

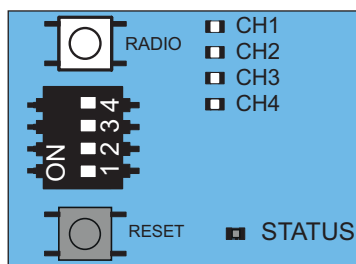

Fig. 1



INFORMATION

- If no transmission command is received within 30 seconds of pressing the Radio button, the radio receiver switches to normal mode.

1. Press the Radio button repeatedly to select the required channel.

10. Connections and special functions of the motor carriage

LED	1 x	2 x	3 x	4 x
CH 1				
CH 2				
CH 3				
CH 4				

- Press the desired button on the transmitter until the previously selected LED (CH 1, CH 2, CH 3, CH 4) goes out.
 - ⇒ **LED goes out - programming is complete.**
 - ⇒ The transmitter has transferred the radio command to the radio receiver.
- Repeat the above steps to program additional transmitters.

If the memory capacity has been reached

A total of 40 handheld transmitter commands are available for all channels. If an attempt is made to program additional transmitters, the red LEDs of radio channels CH 1–4 blink. If more memory positions are needed, see Chapter "10.6 Information on Memo".

10.6 Information on Memo

The use of the Memo depends on the version of the motor carriage circuit board. The memory capacity can be extended to 450 handheld transmitter commands using the optional Memo accessory part. When the Memo is plugged in, all available transmitters are transferred from the internal memory to the Memo and stored there. The Memo must remain plugged in on the control unit.

No more transmitters are then stored in the internal memory. Stored transmitters cannot be transferred from the Memo back to the internal memory.

All radio channels, including the memory of the Memo, can be deleted, see chapter "10.11 Deleting all radio channels in the receiver".



INFORMATION

- Delete a Memo on which data has been stored on a new operator. Otherwise, all stored transmitters of an operator are deleted and must be reprogrammed.

10.7 Cancelling programming mode

- Press the Radio button until all LEDs are off or make no input for 30 seconds.
 - ⇒ Programming mode is cancelled.

10.8 Deleting a transmitter button from the radio channel

- Press the Radio button repeatedly to select the required radio channel. Press and hold the Radio button for 15 seconds.

LED	1 x	2 x	3 x	4 x
CH 1				
CH 2				
CH 3				
CH 4				

- ⇒ The LED blinks after 15 seconds.
- Release the Radio button.
 - ⇒ The radio receiver is now in deletion mode.
 - Press the transmitter button for which the radio command is to be deleted in the radio channel.
 - ⇒ LED goes out.
 - ⇒ The deletion procedure is ended.
- Repeat the process for additional buttons as required.

10.9 Deleting transmitter completely from the receiver

- Press and hold the Radio button for 20 seconds.
 - ⇒ The LED blinks after 15 seconds.
 - ⇒ After another 5 seconds, the flash sequence changes to flashing.
- Release the Radio button.
 - ⇒ The radio receiver is now in deletion mode.
- Press any button on the transmitter that is to be deleted.
 - ⇒ LED goes out.
 - ⇒ The deletion procedure has been completed.
 - ⇒ The transmitter is deleted from the radio receiver.

Repeat the process for additional transmitters as required.

10.10 Deleting a radio channel in the receiver

- Press the Radio button repeatedly to select the required radio channel. Press and hold the Radio button for 25 seconds.

10. Connections and special functions of the motor carriage

LED	1 x	2 x	3 x	4 x
CH 1				
CH 2				
CH 3				
CH 4				

- ⇒ The LED blinks after 15 seconds.
- ⇒ After another 5 seconds, the flash sequence changes to flashing.
- ⇒ After another 5 seconds, the LED of the selected radio channel remains steady.

2. Release the Radio button.

- ⇒ The deletion procedure is ended.
- ⇒ All programmed transmitters on the selected radio channel are deleted from the radio receiver.

10.11 Deleting all radio channels in the receiver

1. Press and hold the Radio button for 30 seconds.

- ⇒ The LED blinks after 15 seconds.
- ⇒ After another 5 seconds, the flash sequence changes to flashing.
- ⇒ After another 5 seconds, the LED of the selected radio channel remains steady.
- ⇒ After another 5 seconds, all LEDs light up.

2. Release the Radio button.

- ⇒ All LEDs are off after 5 seconds.
- ⇒ **All programmed transmitters are deleted from the receiver.**
- ⇒ **Receiver is completely deleted; this also applies if the Memo is plugged in.**

10.12 Programming a second handheld transmitter by radio (HFL)

Prerequisites for programming by radio

A handheld transmitter must already be programmed on the radio receiver. The handheld transmitters used must be identical. This means, for example, that a Pearl can only be programmed on a Pearl and a Pearl Vibe on a Pearl Vibe.

The key assignment of handheld transmitter (A) that put the radio receiver into programming mode by radio is used for the new handheld transmitter (B) that is to be programmed. The already-programmed transmitter and the new transmitter to be programmed must be situated within the range of the radio receiver.

Example:

1. Button 1 has been programmed to radio channel 1 and button 2 to radio channel 2 by handheld transmitter (A).

- ⇒ The newly-programmed transmitter (B) adopts the button assignment of transmitter (A): Button 1 on radio channel 1, button 2 on radio channel 2.

Restriction

The following settings are **not** possible:

- This function is not possible with the Pearl Twin handheld transmitter.
- Targeted programming of a selected handheld transmitter button to a radio channel.

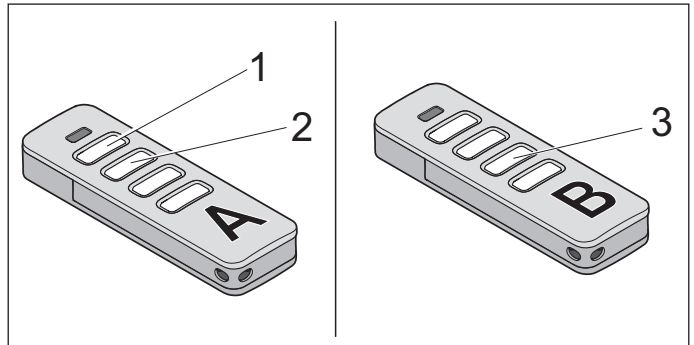

Fig. 1

1. Press buttons 1 and 2 of a programmed handheld transmitter (A) for 3–5 seconds until the LED on the handheld transmitter briefly lights up.
 - ⇒ The operator lighting flashes.
2. Release buttons 1 and 2 of handheld transmitter (A).
 - ⇒ If **no** radio command is transmitted within another 30 seconds, the radio receiver switches over to normal mode.
3. Press any button, e.g. (3) on the new handheld transmitter (B) to be programmed.
 - ⇒ The LEDs of the operator lighting remain steady.
 - ⇒ The second handheld transmitter (B) has been programmed.

10.13 Carrying out a reset

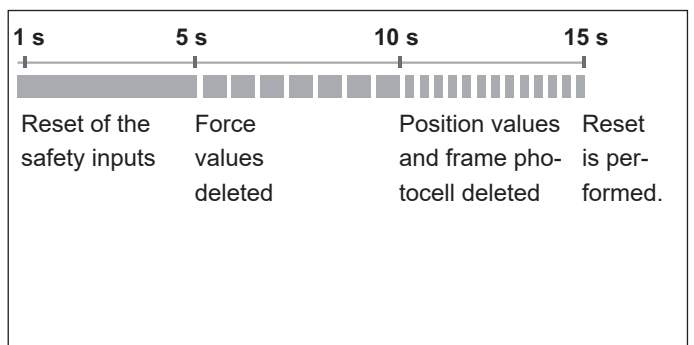

Fig. Overview of the time sequence of the motor carriage status LED when pressing the green Reset button

10. Connections and special functions of the motor carriage

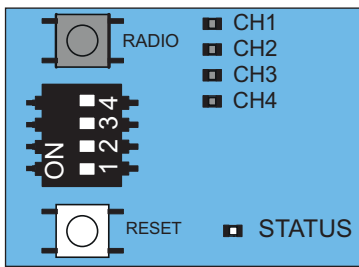

Fig. 1



INFORMATION



- A SOMlink and a WiFi-enabled device are required to reset all parameters to the factory setting.
- The DIP switches can only be manually reset.

Resetting the safety devices

1. Press the green Reset button for 1 second.
 - ⇒ Reset of the connected safety devices.
 - ⇒ Subsequently attached safety devices are detected.

Deleting the force values

1. Press the green Reset button on the motor carriage for 5 seconds until the green status LED flashes slowly.
 - ⇒ Force values are deleted.

Deleting force and position values

1. Press the green Reset button on the motor carriage for 10 seconds until the green status LED flashes quickly.
 - ⇒ Force and position values deleted.
 - ⇒ Frame photocell deleted.

Resetting

1. Press the green Reset button on the motor carriage for 15 seconds until the green status LED goes out.
 - ⇒ Reset is performed.

10.14 Setting the DIP switches on the motor carriage

Special functions can be set with the DIP switches on the motor carriage.

For compliance with EN 13241-1, before initial operation, the door type must be selected and set on the motor carriage with the DIP switch. The factory setting of the DIP switches is "OFF," which is then applicable for sectional doors.

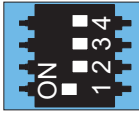
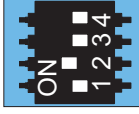
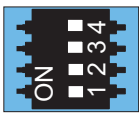
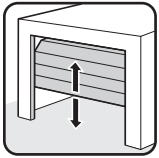
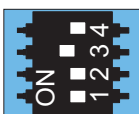
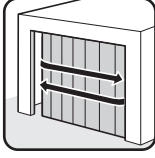
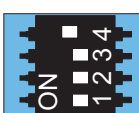
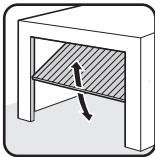
DIP switch on motor carriage	ON	OFF 
1 	• Automatic closing function activated	• Automatic closing function deactivated
2 	• Partial opening activated/ • Lighting function deactivated	• Partial opening deactivated/ • Lighting function activated
3+4 	• No function	
3 		
4 		

10.15 Setting automatic closing function – defining basic values

When automatic closing is activated, the door is opened by a pulse.

The door moves to the door OPEN end position. The door closes automatically after the hold open time. With the factory settings, the door also closes automatically from the partial opening position when the automatic closing function is activated.

WARNING



Risk of injury during automatic closing!

Automatically closing doors can injure people or animals in the movement area of the door when the door is closing. This may cause serious or fatal injury.

- ▶ Always keep the moving door in sight.
- ▶ Keep persons and animals clear of the range of movement of the door.
- ▶ Never put your hand near the door or near moving parts, in particular the ceiling holders or the push arm, when the door is moving.
- ▶ Do not drive through the door until it has opened completely.

10. Connections and special functions of the motor carriage

NOTE

- If the door is not in view and the operator is actuated, objects in the movement area of the door may be jammed and damaged. Objects must not be in the range of movement of the door.

INFORMATION

- The door opens completely if it hits an obstacle.
 - Operation with automatic closing must comply with standard EN 12453. 2017 (Plc). This is a legal requirement. National regulations must be observed in non-European countries.
 - A photocell must be connected. Bridging the safety inputs with jumpers is not permitted.
1. Close the door.
 2. Set DIP switch 1 to "ON" position.
 3. The set hold open time of the door is 60 seconds. Every new command within these 60 seconds restarts the hold open time. The door OPEN position is reached by pressing button 1 on the transmitter. The door movement cannot be stopped with the transmitter.
 4. The door closes automatically after 60 seconds. The closing movement can be stopped by a command with the transmitter.
 - ⇒ Door opens completely - after reversal of direction.
 5. The door starts the closing process again after 60 seconds.
 - ⇒ Door CLOSE.

10.16 Setting the hold open time manually

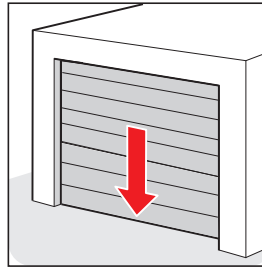

1. Close the door.

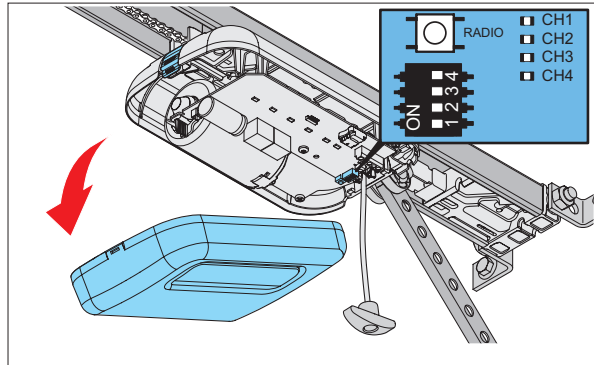

2. Remove the cover.

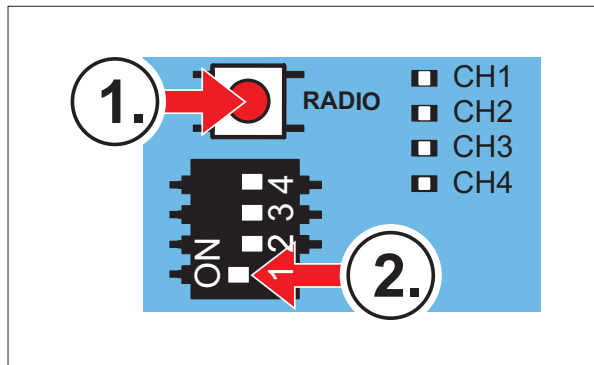

3. First **press and hold** the RADIO button while bringing DIP switch 1 to „ON“.
 - ⇒ The LEDs CH1 + CH3 and CH2 + CH4 light up alternately in pairs for one second each. The hold-open time has been extended by one second each time the LED pairs are changed.

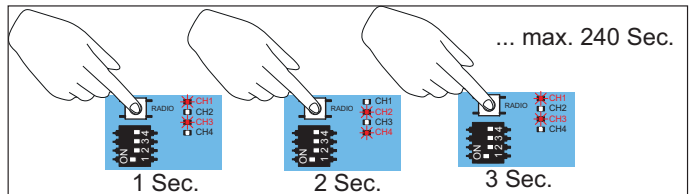

4. Count off the hold-open time at the LED light changes. When the desired duration has been reached, release the RADIO button.

10.17 Setting the lighting function

The operator lighting on the motor carriage can be switched on and off separately via radio channel CH 2. This function is pre-set in the factory settings. Program the desired handheld transmitter button to radio

10. Connections and special functions of the motor carriage

channel CH 2.

The factory setting of DIP switch 2 is "OFF," and the lighting function is therefore activated. The lighting function or partial opening can be operated.

1. Set DIP switch 2 on the motor carriage to "OFF."
2. Press the Radio button repeatedly to select the radio channel CH 2. Program the lighting function on the desired transmitter button.

⇒ The lighting function is available.

The operator lighting can now be switched on and off with the corresponding transmitter button.

Other lights and functions are available with the accessories **Lumi pro+** or **Relay**.

The **Lumi pro+** is an LED strip with 12 LEDs (24 V, 4 W). It can be attached to the wall control unit as supplemental lighting.

The **Relay** (potential-free changeover contact) is pluggable and can be attached to the wall control unit. It can be used for controlling external lighting such as garage lights or courtyard lights. The maximum switching capacity is 5 A/AC 250 V or 5 A/DC 24 V.

Parallel to the operator lighting, the **Lumi pro+** and the **Relay** switch on with the "Start" impulse. The lighting time set at the factory is 180 seconds. If the light function is activated via the CH 2 radio channel, the operator lighting, the **Lumi pro+** and the **Relay** can also be switched on and off separately. This does not trigger a travel command. After 60 minutes, the operator lighting, the **Lumi pro+** or the **Relay** are switched off automatically.

10.18 Setting partial opening

This function allows you to set a desired partial opening. The door then does not open completely, but only to the set door position. The lighting function or partial opening can be operated.

Example:

A side-opening sectional door can be opened to allow a person to pass through. The partial opening function can be used via radio control system or button 2; see Chapter "11.5 Button 2 for partial opening".



INFORMATION

- The lighting function or partial opening can be operated.
- The specified partial opening can be approached from any position of the door.

1. Close the door completely up to the door CLOSE end position.
2. Press the Radio button repeatedly to select radio channel CH 2 and to program the partial opening function to the desired transmitter button.
3. Set DIP switch 2 on the motor carriage to "ON."
4. Press the desired button on the transmitter for the partial opening function.

⇒ The door moves in door OPEN direction.

5. When the door reaches the desired partial opening position, press the button on the transmitter again.
 - ⇒ The door stops at the desired position.

10.19 Deleting partial opening

1. Set DIP switch 2 on the motor carriage to "OFF."
2. Open the door completely up to the door OPEN end position.
 - ⇒ Partial opening is deleted.

To program a new position, see Chapter "10.18 Setting partial opening".

10.20 Wicket door safety device

The wicket door safety device prevents operation of the door with open wicket doors. The wicket door safety device from **SOMMER** meets the requirements of EN 12453: 2017 (Plc). Only the **SOMMER** wicket door switch, Item No. S11474-0001, may be connected.

1. The wicket door safety device must be installed so that the switch reliably detects the open door. Do not install the wicket door safety device on the hinge side.
2. Connect the wicket door safety device on the terminal block on the motor carriage. The contact command is at DC 12 V, 10 mA. The normally closed contact is potential-free.
3. Check the function.



INFORMATION

- If the control unit receives a new command with the wicket door open, the LEDs of the operator lighting change from permanent to flashing light.

10.21 Connecting the safety contact strip

Either an OSE (opto-electronic safety contact strip) or an 8k2 (electric safety contact strip) can be connected. During commissioning, the control unit automatically detects which version it is and sets itself to that version. If a safety contact strip is retrofitted on a programmed system, the control unit must be reset; see Chapter "10.13 Carrying out a reset". As set at the factory, the safety contact strip is only effective in the Close direction. The direction of action can be changed with the SOMlink.

Terminal block	8k2
	gn wh

10. Connections and special functions of the motor carriage

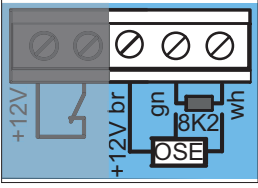
Terminal block	OSE
	+12 V = br OSE = gn GND = wh

The safety contact strip in the door CLOSE direction of motion is triggered:

- ⇒ Operator stops and opens the door slightly.
- ⇒ The obstacle is released.



INFORMATION

- In automatic closing operating mode, the operator stops and opens the door completely. The door closes automatically after the hold open time. If the door encounters the obstacle again, the operator stops and reverses completely to the door OPEN end position. The door stops there and the automatic closing function is interrupted. The hold open time does not start again until a command is received. The door is then automatically closed.

10.22 12 V output

The use of the 12 V output depends on the version of the motor carriage circuit board.

This output can be used for the power supply of external accessories. Two operating modes are available.

DC 12 V, max. 100 mA are available for them.

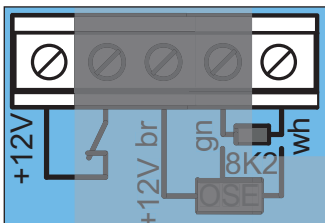

Fig. 12 V output

Operating mode 1 (factory setting)

Power supply for external devices, for example finger scanners mounted in the door panel. Power-saving mode must be deactivated for this operating mode. To do this, set dip switch 3 on the ceiling control unit to "ON"; see Chapter "13.4 Power-saving mode."

Operating mode 2 (external lighting)

In this operating mode, external lighting can be connected and switched via the CH2 radio channel, for example lighting with LEDs.

With this function, the operator lighting works with reduced illumination power. In the "External lighting" operating mode, the OSE/8k2 safety device can no longer be used on the motor carriage.

10.23 SOMlink

SOMlink is a combination of an additional device and a web-based application. Since safety-relevant values can also be changed, SOMlink is only sold to **qualified specialists**. **Qualified specialists only** can use the SOMlink to change functions and settings on the door operator. These include force and speed values as well as operating parameters and other convenient functions. All changes to settings via the SOMlink are logged.

You can access a demo version of the WEB APP under: http://www.sommer-projects.de/gta_app/#home



INFORMATION



- All operator parameters are reset to the factory settings by a factory reset. All settings via SOMlink and WiFi-enabled device are also reset.
- The DIP switches can only be manually reset.

11. Connections and special functions of the wall control unit

11.1 Wall control unit circuit board

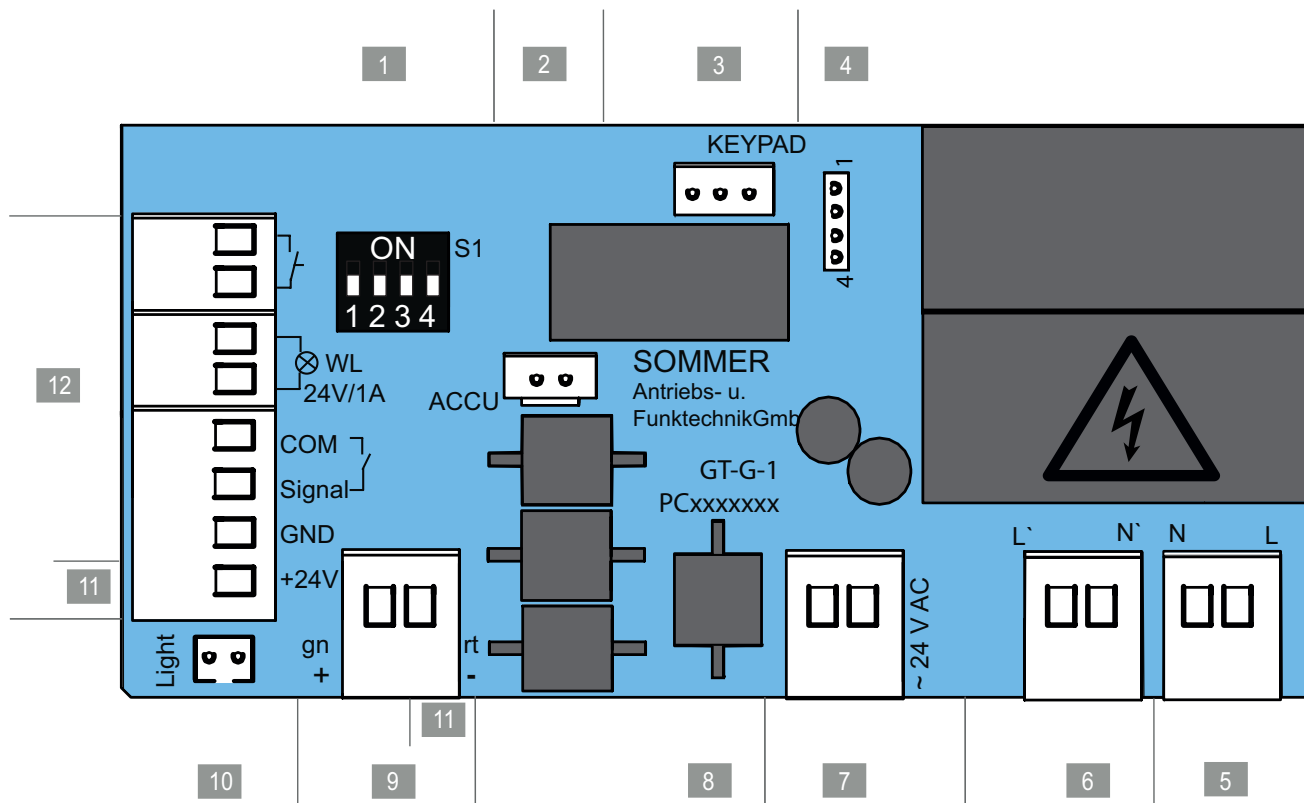

Fig. Wall control unit circuit board, complete version*

Connection options to the wall control unit



1	DIP switches	7	2-pin terminal block Secondary side transformer, AC 24 V
2	ACCU slot Terminal for accumulator	8	Circuit board label
3	Slot, KEYPAD Terminal for the keypad connection cable of the pro+ wall control unit or Conex connection	9	2-pin terminal block Chain (rd) and track (gn), DC 24 V
4	Slot Terminal for relay, output OC	10	Light slot, white Terminal for supplemental lighting Lumi pro+
5	2-pin terminal block Supply voltage AC 220–240 V, 50/60 Hz	11	Terminal blocks, external accessories, DC 24 V
6	2-pin terminal block Primary side transformer AC 220–240 V, 50/60 Hz	12	8-pin terminal blocks <ul style="list-style-type: none"> • button 1, pulse sequence • Warning light (DC 24 V, max. 25 W) • 2-/4-wire photocell • (max. 100 mA regulated) • or button 2, partial opening

* The version can vary depending on the type. This means the use of accessories can vary.

A connection diagram can be found in Chapter "18. Connection diagrams and functions of the DIP switches pro/pro+".

11. Connections and special functions of the wall control unit

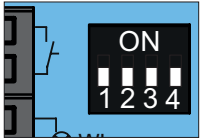
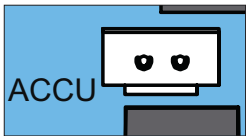
11.2 Connection options to the wall control unit

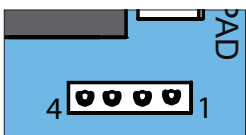
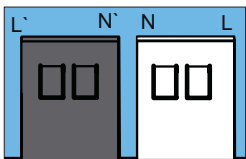
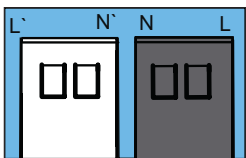
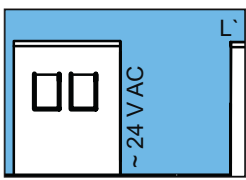
Circuit board section	Function/application example						
1 DIP switches							
							
3 ACCU slot	Terminal for accumulator						
							
3 KEYPAD slot, CONEX, black	Terminal for the keypad connection cable of the pro+ wall control unit and Conex connection						
							
4 Relay slot, output OC	<table border="0"> <tr> <td>Relay</td> <td>Output OC</td> </tr> <tr> <td>max. AC 250 V, 5 V</td> <td>max. AC 24 V</td> </tr> <tr> <td>or: max. DC 24 V, 4 A</td> <td>or: max. 750 mA</td> </tr> </table>	Relay	Output OC	max. AC 250 V, 5 V	max. AC 24 V	or: max. DC 24 V, 4 A	or: max. 750 mA
Relay	Output OC						
max. AC 250 V, 5 V	max. AC 24 V						
or: max. DC 24 V, 4 A	or: max. 750 mA						
							
5 Terminal block, power supply, 2-pin	AC 220–240 V, 50/60 Hz						
							
6 Terminal block, transformer primary side, 2-pin	AC 220–240 V, 50/60 Hz						
							
7 Terminal block, transformer secondary side, 2-pin	AC 24 V						
							
8 Circuit board label							

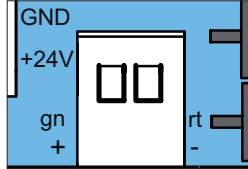
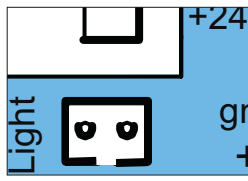
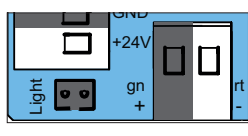
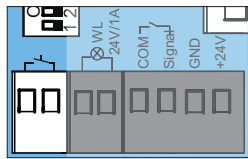
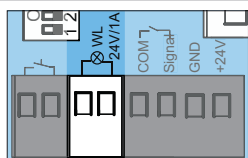
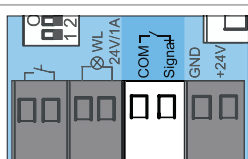
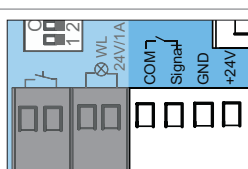
Circuit board section	Function/application example
9 Terminal block, chain and track, 2-pin	DC 24 V
	
10 Lumi pro+ slot, white, 2-pin	Light Supplemental lighting
	
11 Terminal blocks	External accessories DC +24 V (terminal block photocell) GND = rd (terminal block chain/track) max. 100 mA, (max. 500 mA if an LED warning light with a max. of 3 W or no warning light is connected)
	
12 Terminal blocks	Button, 2-pin potential-free Warning light, 2-pin DC 24 V, max. 25 W 2-wire photocell, 2-pin Any polarity or button 2, partial opening 4-wire photocell, 4-pin DC +24 V, 100 mA (regulated)
	
	
	
	

The version can vary depending on the type. This means the use of accessories can vary.

11. Connections and special functions of the wall control unit

⚠ WARNING



Danger of crushing and shearing!

The door can be actuated by a button. Persons who cannot see the door and are in the range of movement of the mechanism or the safety edges may be injured by crushing or shearing.

- ▶ Keypads and other command devices may only be installed within view of the door.
- ▶ Only use keypads or other command devices when you can see the movement of the door.
- ▶ All danger zones must be visible during the entire door operation.
- ▶ Always keep the moving door in sight.
- ▶ Keep persons and animals clear of the range of movement of the door.
- ▶ Never stand under the opened door.

⚠ WARNING



Danger due to hot surfaces!

After frequent operation, parts of the motor carriage or the control unit may become hot. If the control unit cover is removed and hot parts are touched, they may cause burns.

- ▶ Allow the operator to cool down before removing the cover.

NOTE

- Never lay the control cable along a power line as this could cause interference in the control unit. Note the length of the control cable and install it correctly.
- Do not use a metal object to set the DIP switches, because this may damage the DIP switches or the circuit board.
Use a suitable tool to set the DIP switches, such as a flat, thin plastic object.







INFORMATION

- The control unit detects a short-circuit between chain and track and then switches the operator off. If the short circuit is no longer present, the operator runs normally again.
- Control or regulating units in a fixed position must be mounted within sight of the door and at a height of at least 1.5 m.
- The power cable is approx. 1.2 m long.
- The maximum cable length for connected accessories is 30 m.

11.3 Setting the DIP switches on the wall control unit

Special functions can be set with the DIP switches on the wall control unit. All DIP switches are set to "OFF" in the factory settings.

DIP switch on wall unit	ON	OFF
 1 	<ul style="list-style-type: none"> • Membrane keypad T1 for defined door OPEN • Membrane keypad T2 defined door CLOSE 	<ul style="list-style-type: none"> • Membrane keypad T1 for pulse sequence • Membrane keypad T2 lighting function/partial opening
2 	<ul style="list-style-type: none"> • Relay (MUFU) trips: during door movement and if the door is not closed* 	<ul style="list-style-type: none"> • Relay (MUFU) lighting function
3 	<ul style="list-style-type: none"> • Continuous power to the complete system activated 	<ul style="list-style-type: none"> • Power-saving mode activated
4 	<ul style="list-style-type: none"> • COM and Signal activated as button input (partial opening) 	<ul style="list-style-type: none"> • COM and Signal activated as safety contact for photocell

* e.g.: Door status display

11.4 Button assignment of wall control unit

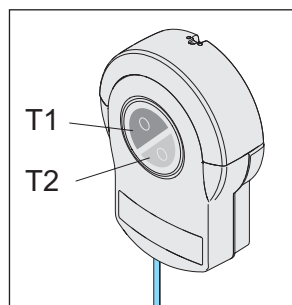

Fig. Membrane keypad T1 and T2 of wall control unit

Factory settings of the functions

- Membrane keypad T1 – Pulse button
- Membrane keypad T2 – lighting function or partial opening, dependent on DIP switch 2 on motor carriage

Setting options via the wall control unit

If DIP switch 1 is set to "ON" on the wall control unit:

- Membrane keypad T1 – defined OPEN
- Membrane keypad T2 – defined CLOSE

11. Connections and special functions of the wall control unit

11.5 Button 2 for partial opening

If required, a further button can be connected to the control unit for partial opening operation. After installation of the keypad, all settings must be made on the ceiling control unit and the motor carriage.

NOTE

- If an accumulator has been installed, it is connected to the circuit board. Carefully remove the control unit cover and disconnect the connections to prevent damage to the wall control unit.

INFORMATION

- If button 2 (partial opening) is used, a photocell cannot be connected. The automatic closing operating mode is then not possible.

Installing the keypad

1. When installing the potential-free keypad, select a suitable position at a height of at least 1.5 m.
2. Install the keypad.
3. Route the keypad cable to the wall control unit and secure it firmly to prevent displacement.

Installing the control cable and settings on the wall control unit

1. Disconnect the operator from the mains voltage. Check that the operator is disconnected from the power supply.
2. Unscrew the light cover from the wall control unit and remove it upwards. Hold the front cover firmly while doing so.
3. Remove the control unit cover gently towards the front and unplug the connection cable for the membrane keypad from the wall control unit; see Chapter "7.2 Light and control unit cover of the wall control unit".
4. If an accumulator is used, it must also be disconnected, see Chapter "11.11 Installing and removing the accumulator":
5. Remove the control unit cover.

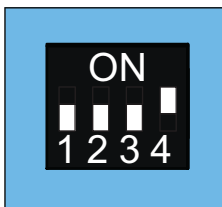
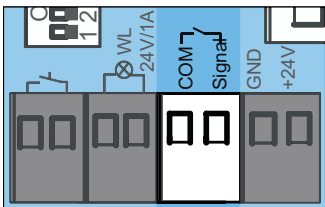

Fig. 6

Fig. 7

6. Connect the cable of button 2 to the terminal block for COM and Signal.
⇒ Button 2 is connected.
7. Set DIP switch 4 on the wall unit to "ON."
8. Plug in the connection cable for the button and for the accumulator, if necessary.

9. Close the wall control unit in reverse order; see Chapter "11.11 Installing and removing the accumulator" and "7.2 Light and control unit cover of the wall control unit".

10. Supply the operator with mains voltage.
Check that the power supply is connected.

Settings on the motor carriage

To change the partial opening function, see Chapter "10.18 Setting partial opening" or "10.19 Deleting partial opening".

11.6 Photocell and frame photocell

A 2-wire or 4-wire photocell from SOMMER can be connected to the control unit. The control unit automatically detects which version it is and sets itself to that version. We recommend installing the photocell at a height of up to 300 mm.

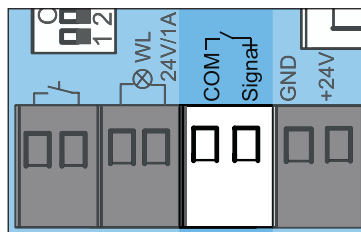

Fig. Terminal block for a 2-wire photocell

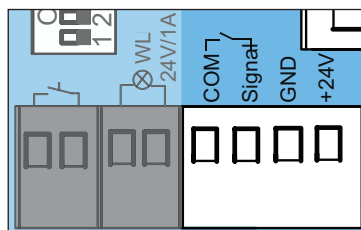

Fig. Terminal block for a 4-wire photocell

INFORMATION

- If a photocell is retrofitted on a programmed system, the control unit must be reset, see Chapter "10.13 Carrying out a reset".
- During commissioning, the frame photocell must not be interrupted by persons or objects.
- If a photocell is used as a frame photocell on the door, move the door to the centre position.

Frame photocell

1. Install the frame photocell in the frame; see separate instructions for "Frame photocell."
2. Align the frame photocell and connect it to the wall control unit.
3. Initial operation is performed as described in Chapter "9. Initial operation".

11. Connections and special functions of the wall control unit

- ⇒ When the door passes the frame photocell, the illumination power of the operator lighting is reduced.
If the illumination power is not reduced, the frame photocell must be realigned. The control unit must also be reset.
- ⇒ During initial operation, the operator learns the exact position of the frame photocell in order to blank it out in normal mode shortly before reaching the door.
4. Check the frame photocell function.
Repeat the process if necessary.

11.7 Wallstation

Other functions are available with the Wallstation. For example, a travel command can be executed, the lighting can be switched on or off or the operator can be locked. The selection of the locked areas can be changed via SOMlink. The connection features a polarity-protected 2-wire bus.

The Wallstation is only supported by operators from 07/2017.

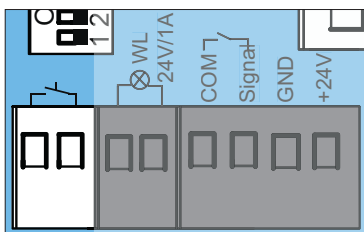

Fig. Button connection

Installing the Wallstation

See the separate instructions for the "Wallstation" for installation.

1. The following conditions must be met for installation of the Wallstation:
 - a second separate access point
 - a suitable position at a minimum height of 1.5 m.
1. Install the Wallstation.
2. The cable from the Wallstation to the wall control unit must be firmly routed and secured to prevent displacement.
3. Connect the Wallstation to the button terminal.
4. The power-saving mode must be deactivated. To do this, set DIP switch 3 on the wall control unit to "ON."

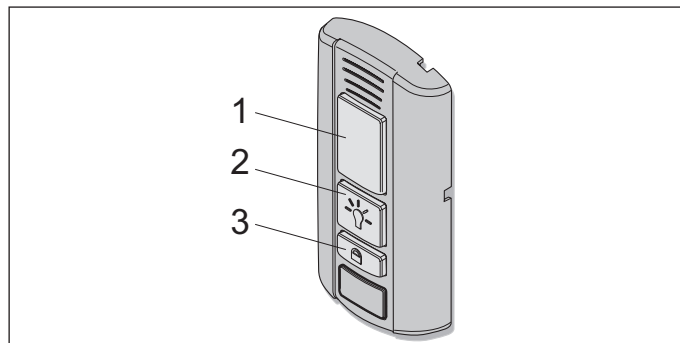

Fig. Wallstation

Functions of the buttons

- (1) Opening, stopping and closing the door
- (2) Turning the lighting on and off
- (3) Locking or unlocking the operator

Opening, closing and stopping the door

1. Press the button (1) to open and close.
⇒ The door opens or closes depending on the starting position.
2. Press the button (1) during the opening or closing process.
⇒ The door stops:
3. Press the button (1) again.
⇒ The door moves into the respective starting position.

Turning the lighting on and off

The button (2) lights up green when the Wallstation is ready for operation and the operator is not locked.

1. Press the button (2).
⇒ Operator lighting switched on
2. Pressing the button (2) again switches the operator lighting back off.
⇒ Operator lighting off.

The lighting cannot be switched off when the operator is moving.

Locking or unlocking the operator

Unauthorised access can be prevented by locking the operator. For example in the absence of the user or to prevent unintentional activation with a handheld transmitter.

The following functions are deactivated in the factory settings when the lock button is activated:

- Radio (handheld transmitter)
- Senso ventilation function
- Command device (corded external button)

To lock

The button (2) on the Wallstation lights up green when the operator is unlocked. The button (2) lights up red when the operator has been locked by the Wallstation. If the door was still open, it can be closed using the handheld transmitter. Only then are all operator functions locked.

11. Connections and special functions of the wall control unit

- Press and hold the button (3) for at least 5 seconds with the door closed.
 - ⇒ Button (2) flashes green.
 - ⇒ After 5 seconds, button (2) lights up red. Locking function activated.
 - All the functions of the operator are locked.

To unlock

- Press the button (3) for at least 5 seconds.
 - ⇒ Button (2) flashes red.
 - ⇒ Button (2) lights up green.
 - ⇒ Locking function deactivated.
 - All the functions of the operator are activated again.

11.8 Conex

Two corded external buttons can be connected to the KEYPAD connection with the Conex accessory part. The function of the external buttons can be configured via DIP switch 1 of the wall control unit. The factory setting of DIP switch 1 is "OFF."

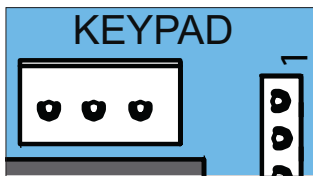



Fig. Keypad connection

The Conex accessory part is plugged into the KEYPAD slot on the wall control unit; see separate "Conex" instructions.

DIP switches on the wall control unit	ON	OFF 
1 	<ul style="list-style-type: none"> "Conex" additional circuit board T1 defines door OPEN T2 defines door CLOSE 	<ul style="list-style-type: none"> "Conex" additional circuit board T1 pulse sequence T2 lighting function/partial opening

11.9 Output OC

The door status display can be shown with the Output OC (open collector output) accessory part. To do this, set DIP switch 2 on the wall control unit to "ON."

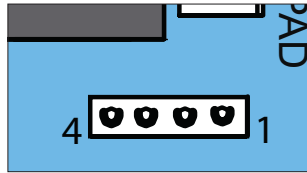

Fig. Relay slot for Output OC

The Output OC accessory part is plugged into the Relay slot on the wall control unit; see separate instructions for "Output OC."

11.10 Relay

External lighting such as the garage light, courtyard light or door status display can be controlled with the relay accessory part. The function depends on the setting of the DIP switches. See also Chapter "11.3 Setting the DIP switches on the wall control unit".

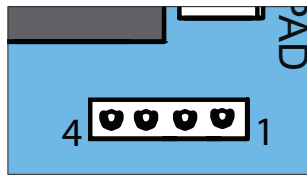

Fig. Relay slot

The Relay is plugged into the Relay slot on the wall control unit; see separate "Relay" instructions.

11.11 Installing and removing the accumulator

The accumulator can bridge approximately 5 cycles within 12 hours in the event of a power failure. The accumulator can only be recharged for a limited number of cycles. This depends on the use and settings. Mains voltage is required for initial operation of the operator. Only a **qualified electrician** is permitted to install, test and replace the accumulator. See Chapter "7.1 Cover of the motor carriage". Follow the instructions in the separate installation and operating manual for the accumulator.

→ NOTE

- If an accumulator has been installed, it is connected to the circuit board. Carefully remove the control unit cover and disconnect the connections to prevent damage to the wall control unit.

Installing the accumulator

- Disconnect the operator from the mains voltage. Check that the operator is disconnected from the power supply.

11. Connections and special functions of the wall control unit

2. Unscrew the light cover from the wall control unit and remove it upwards. Hold the front control unit cover firmly while doing so; see Chapter "7.2 Light and control unit cover of the wall control unit".
3. Remove the control unit cover gently towards the front and unplug the connection cable for the membrane keypad from the wall control unit.

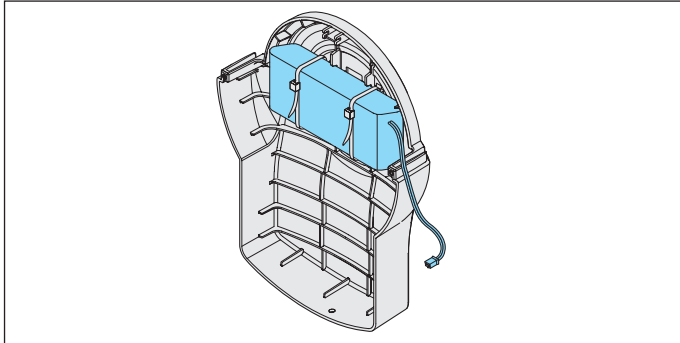

Fig. 4

4. Place the accumulator in the control unit cover and fasten with two cable binders.

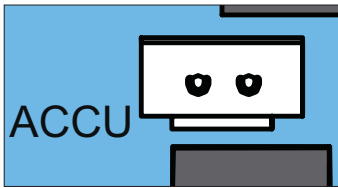

Fig. 5

5. Place the control unit cover on the bottom of the wall control unit and plug the connection cable for the accumulator into the ACCU slot.
6. Set DIP switch 3 on the wall control unit to "ON."
7. Plug the connection cable for the membrane keyboard into the circuit board; see Chapter "7.2 Light and control unit cover of the wall control unit".
8. Place the control unit cover on the wall unit and screw on the light cover.
9. Supply the operator with mains voltage. Check that the power supply is connected.

Removing the accumulator

The accumulator is removed in reverse order; see Chapter "11.11 Installing and removing the accumulator".

⚠ WARNING



Danger of hazardous substances!

Improper storage, use or disposal of accumulators, batteries and operator components are dangerous for the health of humans and animals. Serious injury or death may result.

- ▶ Accumulators and batteries must be stored out of the reach of children and animals.
- ▶ Keep accumulators and batteries away from chemical, mechanical and thermal influences.
- ▶ Do not recharge old accumulators and batteries.
- ▶ Components of the operator as well as old accumulators and batteries must not be disposed of with household waste. They must be disposed of properly.

➔ NOTE

- Dispose of all components in accordance with local and national regulations to avoid environmental damage.



INFORMATION

- All components that have been taken out of service, old accumulators and operator batteries must not be disposed of with household waste. Dispose of components which are no longer in use, old accumulators and batteries properly. You must observe the local and national regulations.

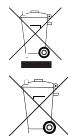

12. Function test and final test

12.1 Testing obstacle detection

After initial operation of the operator, the force setting of the operator must be checked with a force measurement device and an obstacle detection test must be performed. In particular, observe the warnings below.

WARNING



Danger due to projecting parts!

Parts must not project into public roads or footpaths. This also applies while the door is moving. Persons and animals may be seriously injured.

- ▶ Keep public roads and footpaths clear of projecting parts.



Danger of entrapment!

If the force setting is too high, persons or animals in the movement area of the door may be trapped and pulled along with the door. Severe injuries or death may result.

- ▶ The force setting is relevant to safety and must be carried out by a trained specialist.
- ▶ You must proceed with extreme caution if you check and if necessary adjust the force setting.
- ▶ Check the force setting at monthly intervals.



Danger of entrapment!

If the force setting is too high, persons or animals in the movement area of the door may be trapped by the door. Severe injuries or death may result.

- ▶ The obstacle recognition must be checked at monthly intervals and if necessary, set using an object with a height of 40 mm placed on the ground.



Danger of crushing and shearing!

If the door moves and there are persons or animals in the movement area, crushing and shearing injuries may be caused by the mechanism and safety edges of the door.

- ▶ Note that obstacle recognition does not operate below 40 mm.
- ▶ The obstacle detection must be tested once a month using an object with a height of 40 mm.
- ▶ Only use the operator when you have a direct view of the door.
- ▶ All danger zones must be visible during the entire door operation.
- ▶ Always keep the moving door in sight.
- ▶ Keep persons and animals clear of the range of movement of the door.
- ▶ Never put your hand near the door when it is moving or near moving parts. In particular, do not reach into the moving push arm.
- ▶ Do not reach into the ceiling suspension unit when the motor carriage is running along the track.
- ▶ Do not drive through the door until it has opened completely.
- ▶ Never stand under the opened door.



NOTE

- Observe the national standards, guidelines and regulations for cut-off of the operating forces.
- The obstacle detection must be tested once a month to prevent damage to the operator.



INFORMATION

- After installation of the operator, the person responsible for the installation must complete an EC Declaration of Conformity for the door system in accordance with Machinery Directive 2006/42/EC and apply the CE mark and a type plate. This documentation and this Installation and Operating Manual must be handed over to the user.
This also applies if the operator is retrofitted to a manually operated door.
- Reversing: The operator stops on contact with an obstacle and then moves a short distance in the opposite direction to release the obstacle. In the automatic closing function, the door opens completely if an obstacle is detected.

After successful testing of the force setting, the obstacle detection and the functions, the **qualified specialist** must issue the EC Declaration of Conformity and attach the CE mark and type plate to the door system.

12. Function test and final test

If it is possible for a person to be carried along with the (horizontally or vertically moving) door, it must be checked whether the operator is capable of lifting the weight of a person. The operator must reverse in the door OPEN direction when it is loaded with a weight of 20 kg. The weight is fastened in the centre of the bottom edge of the door for this purpose. This applies to doors with a door opening of over 50 mm.

The door must reverse during the door CLOSE movement if it hits an obstacle with a height of 40 mm on the ground.

1. Open the door with the operator.
2. Place a 40-mm-high object in the centre of the door.

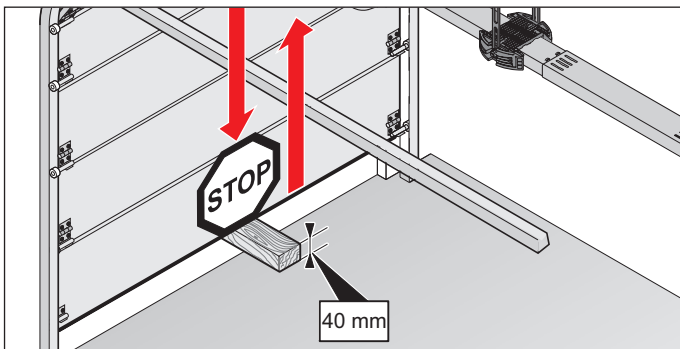

Fig. Example: Obstacle detection on sectional door

3. Close the door with the operator.
 - ⇒ If the door hits an obstacle, the operator must immediately reverse.
 - ⇒ The operator opens the door completely at a pulse from the transmitter.
 - ⇒ If the operator does not reverse, a position reset is required; see Chapter "**10.13 Carrying out a reset**". The positions and the forces must be reprogrammed.
4. The function of the emergency release must be checked, **particularly** in the door CLOSE end position and if necessary, also from outside. Unlocking must be possible; see Chapter "**13.7 Function of the emergency release**".

12.2 Handover of the door system

You can find important information on handover to the user in Chapter "**1.10 Qualifications of personnel**", section "**Instructing the user and handing over documents**".

13. Operation

13.1 Important notes and information

In particular, observe the following warnings and Chapters "14. Maintenance and care" and "15. Troubleshooting".

DANGER



Danger if not observed!

If warnings are not observed, serious injury or death may result.

- ▶ All warnings must be complied with.

WARNING



Danger due to use of the operator with incorrect settings or when it is in need of repair!

If the operator is used despite incorrect settings or if it is in need of repair, severe injury or death may result.

- ▶ The operator may only be used with the required settings and in the proper condition.
- ▶ You must have faults repaired professionally without delay.



Danger due to falling parts of doors!

Actuating the emergency release can lead to uncontrolled door movement if:

- springs are weakened or broken.
- the door has not been optimally weight-balanced.

Falling parts may cause a hazard. Severe injuries or death may result.

- ▶ Check the weight balance of the door at regular intervals.
- ▶ Pay attention to the movement of the door when the emergency release is actuated.
- ▶ Keep clear of the movement area of the door.
- ▶ Keep persons and animals clear of the range of movement of the door.



Danger of entrapment!

Persons or animals in the movement area of the door may be trapped and pulled along with the door. Severe injuries or death may result.

- ▶ Keep clear of the moving door.



Danger of crushing and shearing!

If the door moves and there are persons or animals in the movement area, crushing and shearing injuries may be caused by the mechanism and safety edges of the door.

- ▶ Only use the operator when you have a direct view of the door.
- ▶ All danger zones must be visible during the entire door operation.
- ▶ Always keep the moving door in sight.
- ▶ Keep persons and animals clear of the range of movement of the door.
- ▶ Never put your hand near the door when it is moving or near moving parts. In particular, do not reach into the moving push arm.
- ▶ Do not reach into the ceiling suspension unit when the motor carriage is running along the track.
- ▶ Do not drive through the door until it has opened completely.
- ▶ Never stand under the opened door.



Danger due to optical radiation!

Looking into an LED at short range for an extended period may cause optical glare. This may temporarily reduce vision. This may cause serious or fatal accidents.

- ▶ Never look directly into an LED.



NOTE

- If the weight compensation of the door is incorrectly adjusted, the operator may be damaged.
 - The door must be stable.
 - It must not bend, rotate or twist when opening and closing.
 - The door must move easily in its tracks.Defects must be repaired without delay by a **qualified specialist**.
- Objects in the movement area of the door may be jammed and damaged. Objects must not be in the range of movement of the door.

13.2 Handover to the user

You can find important information on handover for the user in Chapter "1.11 Information for the user".



INFORMATION

- Keep this Installation and Operating Manual accessible at all times at the place of use.

13. Operation

13.3 Operating modes of door movement

⚠ WARNING



Danger of crushing and shearing!

The door can be actuated by a keypad or another command device. Persons who cannot see the door and are in the range of movement of the mechanism or the safety edges may be injured by crushing or shearing.

- ▶ Keypads or other command devices may be used only if the movement of the door can be viewed directly.
- ▶ Keep persons and animals clear of the range of movement of the door.
- ▶ Never stand under the opened door.

All functions can be programmed for all buttons.

Button 1 (CH 1)

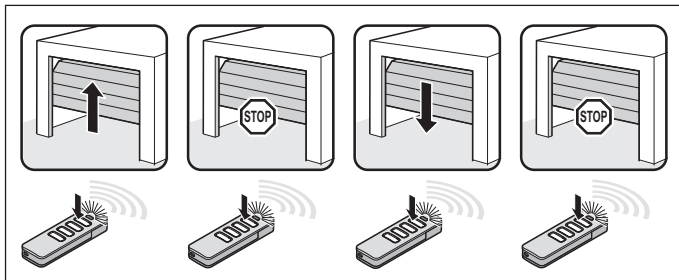

Fig. Pulse sequence door OPEN, door stop, door CLOSE, door stop

Button 2 (CH 2)

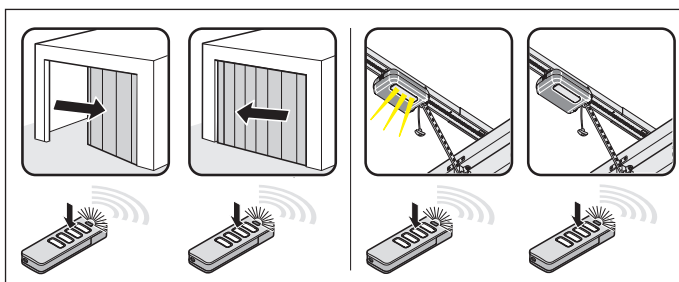

Fig. Pulse sequence for:
 Partial opening: DIP switch 2 "ON"
 Lighting function: DIP switch 2 "OFF"

Button 3 (CH 3)

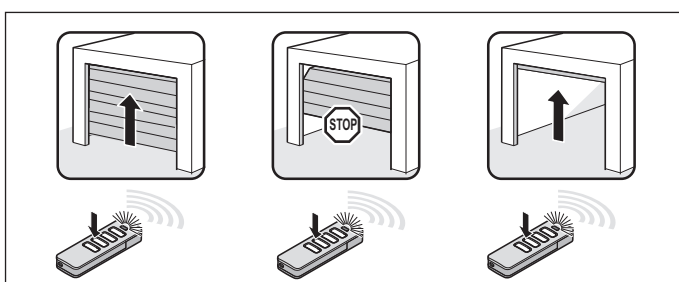

Fig. Pulse sequence for defined door OPEN

Button 4 (CH 4)

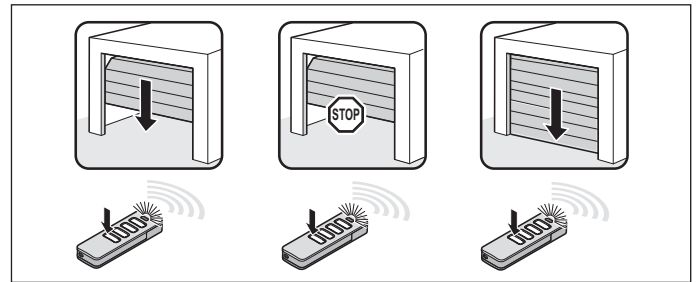

Fig. Pulse sequence for defined door CLOSE

13.4 Testing obstacle detection

The operator stops and reverses slightly if it encounters an obstacle. This prevents injury and damage to property. The door will be partially or completely opened, depending on the setting. The partial reversion is pre-set at the factory.



INFORMATION

- Reversing: The operator stops when it hits an obstacle. The door then moves slightly in the opposite direction to release the obstacle. In the automatic closing function, the door opens completely.

The following safety devices are installed to detect obstacles:



- photocell (object protection)
 - safety contact strips (personal protection)
 - obstacle detection of the operator (personal protection)
- Here, also note Chapter "14. Maintenance and care".

13.5 Power-saving mode

To save energy, the operator control unit switches to power-saving mode. The factory-set period before the control unit switches to power-saving mode is 20 seconds and cannot be changed. Connected accessories are deactivated and then reactivated with the next command via the button or radio. Connected accessories may include: photocell, safety contact strip and external radio receiver.

Because external radio receivers are deactivated in power-saving mode, they cannot receive commands from the remote control and send them to the operator. Set DIP switch 3 to "ON" to power the entire system continuously. Power-saving mode is deactivated.

13. Operation

DIP switch on wall unit 	ON	OFF 
3 	• Continuous power to the complete system activated	• Power-saving mode activated

13.6 In the event of a power failure

The programmed force values and end positions of the operator remain saved in the event of a power failure. After the power supply has been restored, the first movement of the operator after a pulse is always door OPEN.

Also follow the instructions for emergency release in Chapter "11.11 Installing and removing the accumulator" and "13.7 Function of the emergency release".

13.7 Function of the emergency release

In the event of a power failure, the door can be opened from the inside using a mechanical emergency release. Observe in particular the following warnings for this chapter.

WARNING



Danger for trapped persons!

Persons may be trapped inside the garage. If trapped persons cannot free themselves, severe injury or death may result.

- ▶ Check the function of the emergency release at monthly intervals, **particularly** from inside in the door CLOSE end position and if necessary, also from outside.
- ▶ You must have faults repaired professionally without delay.



Danger due to falling parts of doors!

If the emergency release is actuated, weak or broken springs may cause the door to close suddenly and unexpectedly. This may cause serious or fatal injury.

- ▶ The emergency release should be used only with the door closed.
- ▶ Use the emergency release with great caution if the door is open.
- ▶ Keep persons and animals clear of the range of movement of the door.

NOTE

- The emergency release is only suitable for opening or closing the door in an emergency. The emergency release is not suitable for regular opening or closing. This could cause damage to the operator and door. The emergency release must only be used in emergencies such as a power failure.
- During emergency release, the door could open or close by itself surprisingly quickly due to a broken spring or incorrect setting of the weight balancing. Damage to the door system could occur.

- After the operator is locked back in, move the door into the door OPEN end position. Otherwise the guide idler will be hit with too much force.

- Objects in the movement area of the door may be jammed and damaged. Objects must not be in the range of movement of the door.

INFORMATION

- The function of the emergency release must be checked, **particularly** in the door CLOSE end position and if necessary, also from outside. Unlocking must be possible.
- It can be locked and released in any door position.
- The emergency release must be easy to operate in all necessary positions.

1. Disconnect the operator from the mains voltage. Check it is disconnected from the power supply.

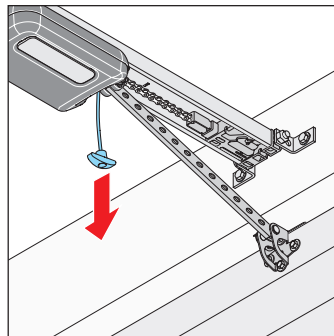

Fig. 2

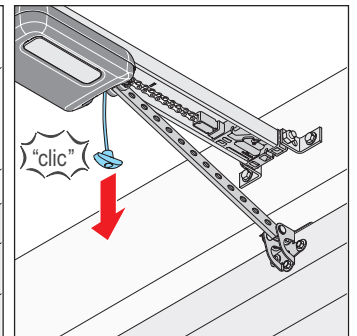

Fig. 3

2. Pull once on the emergency release handle.
 - ⇒ **The motor carriage is released.**
 - ⇒ Door can be moved by hand.
3. Pull the emergency release handle once more.
 - ⇒ **The motor carriage is locked.**
 - ⇒ The door can only be moved by the operator.
4. Re-connect the operator to the voltage supply. Check that the power supply is connected.
5. Give the operator a command.

13. Operation

- ⇒ After a power failure, the first pulse of the operator is always in the door OPEN direction.
- ⇒ The operator must drive completely to the door OPEN end position.

14. Maintenance and care

14.1 Important notes and information

Service the operator regularly as directed below. This ensures safe operation of your operator and a long service life. In particular, observe the warnings below.

DANGER



Danger if not observed!

If warnings are not observed, serious injury or death may result.

- ▶ All warnings must be complied with.



Danger due to electric current!

Contact with live parts may result in electric current flowing through the body. Electric shock, burns or death may result.

- ▶ All work on electrical components must be carried out by a **trained electrician**.
- ▶ Disconnect the mains plug before working on the operator.
- ▶ If an accumulator is connected, disconnect it from the control unit.
- ▶ Check that the operator is not live.
- ▶ Secure the operator against being switched back on.

WARNING



Danger of falling!

Unsafe or defective ladders may tip and cause fatal or serious accidents.

- ▶ Use only a non-slip, stable ladder.
- ▶ Ensure that ladders are safely positioned.



Danger for trapped persons!

Persons may be trapped inside the garage. If trapped persons cannot free themselves, severe injury or death may result.

- ▶ Check the function of the emergency release at monthly intervals, **particularly** from inside in the door CLOSE end position and if necessary, also from outside.
- ▶ You must have faults repaired professionally without delay.



Danger due to falling parts of doors!

Parts of the door may become detached and fall. If persons or animals are hit, this may cause serious injury or death.

- ▶ Always keep the moving door in sight.
- ▶ Keep all persons and animals away from the door until it is completely opened or closed.



Danger of crushing and shearing!

If the door moves and there are persons or animals in the movement area, crushing and shearing injuries may be caused by the mechanism and safety edges of the door.

- ▶ Only use the operator when you have a direct view of the door.
- ▶ All danger zones must be visible during the entire door operation.
- ▶ Always keep the moving door in sight.
- ▶ Keep persons and animals clear of the range of movement of the door.
- ▶ Never put your hand near the door when it is moving or near moving parts. In particular, do not reach into the moving push arm.
- ▶ Do not reach into the ceiling suspension unit when the motor carriage is running along the track.
- ▶ Do not drive through the door until it has opened completely.
- ▶ Never stand under the opened door.



Danger due to hot surfaces!

After frequent operation, parts of the motor carriage or the control unit may become hot. If the cover is removed and hot parts are touched, they may cause burns.

- ▶ Allow the operator to cool down before removing the cover.

NOTE

- The motor carriage is supplied with safety low voltage via the chain and the track. The use of oil or grease will greatly reduce the conductivity of the chain, track and motor carriage. This may result in faults due to inadequate electrical contact. The chain and track are maintenance-free and must not be oiled or greased.
- The use of unsuitable cleaning agents may damage the surface of the operator. Clean the operator with a dry lint-free cloth only.

14. Maintenance and care

14.2 Maintenance schedule

How often?	What?	How?
Once a month	• Test the emergency release	• See Chapter "13.7 Function of the emergency release"
	• Test obstacle detection	• See Chapter "13.4 Testing obstacle detection"
	• Test photocell	• Interrupt the active photocell while the door is closing. The door must stop and open slightly. If automatic closing is activated, the door opens completely. • If necessary, clean the photocell, see Chapter "14.3 Care"
	• Test obstacle recognition	• See Chapter "12.1 Testing obstacle detection"
Once a year	• Test the door and all moving parts	• As directed by the door manufacturer
	• Check screws on door, ceiling or lintel	• Check that screws are tight and tighten if necessary
As needed	• Chain and track	• maintenance-free
	• Track	• See Chapter "14.3 Care"
	• Clean the housing of the wall control unit and motor carriage	• See Chapter "14.3 Care"

14.3 Care

Clean track, motor carriage and wall control unit

1. Disconnect the operator from the mains voltage.
If an accumulator has been installed, remove the wall control unit cover and disconnect the accumulator from the wall control unit; see also Chapter **"11.11 Installing and removing the accumulator"**.
Then check that the power is disconnected.
2. Remove loose dirt with a moist, lint-free cloth:
 - from the motor carriage and the wall control unit
 - from the track and the inside of the track
3. If required, install the accumulator in reverse order of removal.
Re-connect the operator to the mains voltage. Check the power supply.
⇒ The operator is supplied with voltage.

Cleaning the photocell

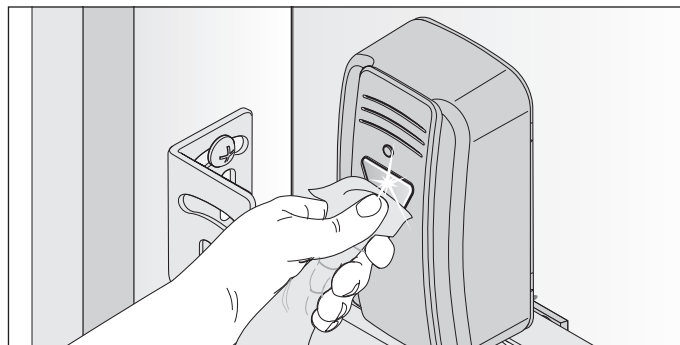

Fig. 1

NOTE

- Do not change the position of the photocell when cleaning it.

1. Clean the housing and reflectors of the photocell with a damp, lint-free cloth.

15. Troubleshooting

15.1 Important notes and information

Observe the basic warnings listed below.

DANGER



Danger if not observed!

If warnings are not observed, serious injury or death may result.

- ▶ All warnings must be complied with.



Danger due to electric current!

Contact with live parts may result in electric current flowing through the body. Electric shock, burns, or death may result.

- ▶ All work on electrical components must be carried out by a **trained electrician**.
- ▶ Disconnect the mains plug before working on the operator.
- ▶ If an accumulator is connected, disconnect it from the control unit.
- ▶ Check that the operator is not live.
- ▶ Secure the operator against being switched back on.

WARNING



Danger of falling!

Unsafe or defective ladders may tip and cause serious or fatal accidents.

- ▶ Use only a non-slip, stable ladder.
- ▶ Ensure that ladders are safely positioned.



Danger for trapped persons!

Persons may be trapped inside the garage. If trapped persons cannot free themselves, severe injury or death may result.

- ▶ Check the function of the emergency release at monthly intervals, **particularly** from inside in the door CLOSE end position and if necessary, also from outside.
- ▶ You must have faults repaired professionally without delay.



Danger due to falling parts!

Parts of the door may become detached and fall. Persons may be hit. Severe injuries or death may result.

- ▶ Always keep the moving door in sight.
- ▶ Keep all persons and animals away from the door until it is completely opened or closed.
- ▶ Do not drive through the door until it has opened completely.



Danger of entrapment!

Loose clothing or long hair may be trapped by moving parts of the door.

- ▶ Keep clear of the moving door.
- ▶ Always wear tight-fitting clothing.
- ▶ Wear a hairnet if you have long hair.



Danger of crushing and shearing!

If the door moves and there are persons or animals in the movement area, crushing and shearing injuries may be caused by the mechanism and safety edges of the door.

- ▶ Only use the operator when you have a direct view of the door.
- ▶ All danger zones must be visible during the entire door operation.
- ▶ Always keep the moving door in sight.
- ▶ Keep persons and animals clear of the range of movement of the door.
- ▶ Never put your hand near the door when it is moving or near moving parts. In particular, do not reach into the moving push arm.
- ▶ Do not reach into the ceiling suspension unit when the motor carriage is running along the track.
- ▶ Do not drive through the door until it has opened completely.
- ▶ Never stand under the opened door.



Danger due to optical radiation!

Looking into an LED at short range for an extended period may cause optical glare. This may temporarily reduce vision. This may cause serious or fatal accidents.

- ▶ Never look directly into an LED.



Danger due to hot surfaces!

After frequent operation, parts of the motor carriage or the control unit may become hot. If the cover is removed and hot parts are touched, they may cause burns.

- ▶ Allow the operator to cool down before removing the cover.



NOTE

- If the door is not in view and the radio remote control is actuated, objects in the movement area of the door may be jammed and damaged. Objects must not be in the range of movement of the door.



INFORMATION

- The control unit detects a short-circuit between chain and track and then switches the operator off.

15. Troubleshooting

15.2 Troubleshooting

The following guide to troubleshooting lists potential problems and their causes and information on correcting them. In some cases, other chapters and sections with a more detailed description are referenced. You will be prompted to call a **qualified specialist** if this is required. Work on the electrical system and live parts must be performed by a **trained electrician**.

1. Disconnect the operator from the mains voltage.
If an accumulator has been installed, remove the control unit cover and disconnect the accumulator from the control unit, see Chapter "**7.2 Light and control unit cover of the wall control unit**" and Chapter "**11.11 Installing and removing the accumulator**".
Then check that the power is disconnected.
2. After working on the operator, if applicable replace the accumulator in reverse order.
3. Connect the operator to the mains voltage.
Check that the power supply is connected.
⇒ The operator is supplied with mains voltage.

15. Troubleshooting





15.3 Time sequences of operator lighting in normal mode and in case of faults

The flash sequences show information on malfunctions for technicians, end customers and telephone support.

In normal mode

Flash sequences	Possible cause	Corrective action
 Operator lighting flashes as warning light	<ul style="list-style-type: none"> • Programming mode activated • Pre-warning time activated • Function for HFI activated 	<ul style="list-style-type: none"> • none, for information
	<ul style="list-style-type: none"> • Interruption of a safety device during the movement 	<ul style="list-style-type: none"> • Remove obstacle

In the event of faults

Flash sequences	Possible cause	Corrective action
Requirement  Operator expects a command	<ul style="list-style-type: none"> • Waiting for a conformation during the position programming movement of door CLOSE end position 	<ul style="list-style-type: none"> • Confirmation of position programming run
for alarm  A process has triggered a fault	<ul style="list-style-type: none"> • Photocell or safety device not OK before movement 	<ul style="list-style-type: none"> • Check photocell and realign if necessary • If necessary, have components replaced by a qualified specialist
	<ul style="list-style-type: none"> • Dead man movement, safety device not OK 	<ul style="list-style-type: none"> • Have it checked by a qualified specialist
	<ul style="list-style-type: none"> • Motor return from outside (e.g. due to attempted break-in) 	<ul style="list-style-type: none"> • For information
Service  A process has triggered a fault	<ul style="list-style-type: none"> • Service (service days, service cycles have been reached) 	<ul style="list-style-type: none"> • Have the service performed by a qualified specialist
	<ul style="list-style-type: none"> • Motor temperature is too high (overheating) 	<ul style="list-style-type: none"> • Allow motor to cool
	<ul style="list-style-type: none"> • Programming of difficult positions in case of reversing with no visible cause. The complete distance is traversed from end position to end position (dead man by radio, under direct view only). 	<ul style="list-style-type: none"> • For information
Fault  Operator or parts of the operator faulty	<ul style="list-style-type: none"> • Self-test of electronics • Blockage detection (gear breakage, Hall sensor fault) 	<ul style="list-style-type: none"> • Have it checked and, if necessary, components replaced by a qualified specialist
	<ul style="list-style-type: none"> • Limit switch does not operate (e.g. wire break, limit switch fault) 	<ul style="list-style-type: none"> • Have cable connections checked by a qualified specialist and, if necessary, have components replaced
	<ul style="list-style-type: none"> • Counting pulses sent in the wrong direction (motor cable was incorrectly connected) 	<ul style="list-style-type: none"> • Check wiring, correct if necessary
	<ul style="list-style-type: none"> • Run time exceeded 	<ul style="list-style-type: none"> • Movement range too long, movement range is restricted to max. 7000 mm
	<ul style="list-style-type: none"> • Error during plausibility test of Memo 	<ul style="list-style-type: none"> • Have it checked and, if necessary, components replaced by a qualified specialist
	<ul style="list-style-type: none"> • Intrinsically safe wicket door contact defective 	<ul style="list-style-type: none"> • Carry out power reset of 20 seconds • If necessary, have component replaced

15. Troubleshooting

15.4 Troubleshooting table

Problem	Possible cause	Test/check	Remedy
The operator opens the door when the transmitter or command device is actuated but does not close it.	• Photocell and safety device interrupted	• Check photocell and safety devices	• Remove obstacle • The photocell must be aligned • If necessary, have it checked and replaced by a qualified specialist
	• Automatic closing function activated	• Wait to see whether the operator starts automatically after 30 seconds	• Automatic closing function deactivated • Have the cause corrected by a trained electrician
Operator cannot be operated with the command device.	• No power	• Check power supply	• Check the power outlet with a different device, for example by plugging in a lamp
	• Limit switch on motor carriage defective	• Unlock operator and push motor carriage to the centre of the track • Lock operator • Actuate transmitter • If the operator still closes the door but does not open it, the limit switch is defective	• Have the limit switch replaced by a qualified specialist
	• The operator was unlocked by the emergency release mechanism	• Check that the door can be moved manually	• Pull the emergency release handle to lock the operator
	• Control device incorrectly connected to the operator	• Check function of operator with a transmitter	• Check wiring and correct if necessary
	• Membrane keypad of the wall unit is not working	• Check cable	• Plug in cable • If necessary, replace wall control unit cover
	• Transmitter defective	• Operator cannot be started with the transmitter	• Check transmitter power supply • If necessary, replace the battery of the transmitter • If necessary, replace the transmitter with a new one
	• Operator defective	• Operator cannot be started with the transmitter or the connected command device	• Have operator repaired or replaced by a qualified specialist
	• Electrical supply voltage outside the approved range	• Have the mains voltage checked by a trained electrician	• Have the cause corrected by a trained electrician
When a button on the transmitter is pressed, the operator does not open or close the door.	• Transmitter not programmed	• Radio LED does not light up when the transmitter is operated	• Programme transmitter
	• Battery in the transmitter is flat		• Replace the battery of the transmitter
	• Transmitter defective	• LED on transmitter does not light up	• Replace transmitter
Radio command cannot be programmed	• Memory full	• All four LEDs for radio flash cyclically for about 3 seconds	• Memory full; see Chapter "10.6 Information on Memo" and "10.8 Deleting a transmitter button from the radio channel"
MEMO Identifier error	• Incorrect MEMO	• All four LEDs for radio flash cyclically for a short time and then go out for a long time. The operator lighting of the motor carriage flashes 4 times short and 4 times long.	• Disconnect operator from the power supply, unplug Memo, re-supply operator with power

15. Troubleshooting

Problem	Possible cause	Test/check	Remedy
MEMO device type error	<ul style="list-style-type: none"> • System error 	<ul style="list-style-type: none"> • All four LEDs blink cyclically for a long time and then go out for a short time. If voltage is present, the operator lighting of the motor carriage flashes an additional four times. 	<ul style="list-style-type: none"> • Memo can be deleted via the Radio button; see Chapter "10.11 Deleting all radio channels in the receiver"
Operator stops the door during closing and opens it partially or completely.	<ul style="list-style-type: none"> • Door has detected an obstacle 	<ul style="list-style-type: none"> • Check whether there are any objects in the movement range of the door 	<ul style="list-style-type: none"> • Remove the object • If necessary, have door mechanism checked and set by a qualified specialist
	<ul style="list-style-type: none"> • Photocell was interrupted 	<ul style="list-style-type: none"> • Check LEDs on photocell 	<ul style="list-style-type: none"> • Remove obstacle
	<ul style="list-style-type: none"> • Photocell defective or misaligned 		<ul style="list-style-type: none"> • Align photocell • Check wiring • If necessary, have defective photocell replaced
Operator stops while the door is opening	<ul style="list-style-type: none"> • Door has detected an obstacle 	<ul style="list-style-type: none"> • Check whether there are any obstacles in the movement range of the door • Check the weight balance of the door - it must run smoothly 	<ul style="list-style-type: none"> • Remove obstacle • If necessary, have door mechanism checked and repaired by a qualified specialist
Operator lighting or the Lumi pro ⁺ supplemental lighting does not function	<ul style="list-style-type: none"> • Operator lighting defective • Lumi pro⁺ supplemental lighting defective 		<ul style="list-style-type: none"> • Have motor carriage replaced with a new one by a qualified specialist • If necessary, replace Lumi pro⁺ supplemental lighting
Speed varies while opening and closing the door	<ul style="list-style-type: none"> • Track dirty 		<ul style="list-style-type: none"> • Clean with a moist, lint-free cloth; see Chapter "14.3 Care"
	<ul style="list-style-type: none"> • Chain tightened incorrectly 		<ul style="list-style-type: none"> • Tighten the chain; see Chapter "6.4 Installing installation variant A or B of the drive system" and "6.5 Installing installation variant C of the drive system"
Motor carriage is pulled away from limit stop	<ul style="list-style-type: none"> • Spring tension is too high, door is opened too far 	<ul style="list-style-type: none"> • Check door operation and spring tension • Check door OPEN end position 	<ul style="list-style-type: none"> • Adjust door operation and spring tension • Adjust door OPEN end position • Fit Lock accessory

15.5 Replacing the motor carriage

The instructions for **"Disassembling the motor carriage"** can be downloaded from **SOMMER** at: www.sommer.eu

If applicable, save the existing settings on the old motor carriage via SOMlink and a WiFi-enabled device. The settings can be transferred to the new motor carriage later.

The new motor carriage is in delivery condition from the factory. After replacing the motor carriage, make sure that used accessories have been transferred to the new motor carriage.

Initial operation must be repeated, and the special functions of the motor carriage must be reset, see chapter **"9. Initial operation"** and **"10. Connections**

and special functions of the motor carriage."

Handheld transmitters which are used must also be reprogrammed, see Chapter **"10.5 Programming the transmitter"**. On the other hand, handheld transmitters do not have to be programmed if the Memo accessory part has already been used.

After successful initial operation, run a function test and a final test; see Chapter **"12. Function test and final test"**.



INFORMATION



- Save the existing settings of the motor carriage with the help of SOMlink and a WiFi-enabled device. After the new motor carriage has been inserted, reinstall the data.

16. Taking out of operation, storage and disposal

16.1 Important notes and information

Disassembly of the operator may only be performed by a **qualified specialist**. Observe the basic warnings listed below.

DANGER



Danger if not observed!

If warnings are not observed, serious injury or death may result.

- ▶ All warnings must be complied with.



Danger due to electric current!

Contact with live parts may result in electric current flowing through the body. Electric shock, burns or death will result.

- ▶ All disassembly work on electrical components must be carried out by a **trained electrician**.
- ▶ Disconnect the power plug before disassembling the operator.
- ▶ If an accumulator is connected, disconnect it from the control unit.
- ▶ Check that the operator is not live.
- ▶ Secure the operator against being switched back on.

WARNING



Danger of falling!

Unsafe or defective ladders may tip and cause serious or fatal accidents.

- ▶ Use only a non-slip, stable ladder.
- ▶ Ensure that ladders are safely positioned



Danger of tripping and falling!

Unsafely positioned parts such as packaging, operator parts or tools may cause trips or falls.

- ▶ Keep the disassembly area free of unnecessary items.
- ▶ Place all parts where no-one is likely to trip or fall over them.
- ▶ The general workplace guidelines must be observed.



Danger due to hot surfaces!

After frequent operation, parts of the motor carriage or the control unit may become hot. If the cover is removed and hot parts are touched, they may cause burns.

- ▶ Allow the operator to cool down before removing the cover.



Danger due to optical radiation!

Looking into an LED at short range for an extended period may cause optical glare. This may temporarily reduce vision. This may cause serious or fatal accidents.

- ▶ Never look directly into an LED.



Risk of eye injury!

Chips flying when drilling may cause serious injuries to eyes and hands.

- ▶ Wear safety glasses when drilling.



Risk of injury in the head region!

Impact with suspended objects may cause serious abrasions and cuts.

- ▶ You must wear a safety helmet when disassembling suspended parts.



CAUTION



Risk of injury to hands!

Rough metal parts may cause abrasions and cuts when picked up or touched.

- ▶ You must wear your personal safety gloves when working with rough metal parts.



NOTE

- If there is an accumulator in the control unit, it must be removed by a trained electrician; see Chapter "11.11 Installing and removing the accumulator".

16.2 Taking the operator out of operation and disassembly

The operator and its accessories must be disconnected from the power supply when taking them out of operation or during disassembly.

1. Pull the power plug out of the power outlet.
If an accumulator has been installed, remove the control unit cover and disconnect the accumulator from the control unit; see also Chapter "11.11 Installing and removing the accumulator". Then check that the power is disconnected.
2. Disassembly is carried out in reverse order of installation.

16.3 Storage

Store the packaging units as follows:

- in enclosed, dry rooms so that they are protected from moisture
- at a storage temperature from -25 °C to $+65\text{ °C}$
- secure to prevent falling
- leave room for unhindered passage

NOTE

- Improper storage may damage the operator. The operator must be stored in closed and dry rooms.

16. Taking out of operation, storage and disposal

16.4 Disposal of waste

Observe the instructions for disposal of packaging, components, batteries and, if applicable, the accumulator.

WARNING



Danger of hazardous substances!

Improper storage, use or disposal of accumulators, batteries and operator components are dangerous for the health of humans and animals. Serious injury or death may result.

- ▶ Accumulators and batteries must be stored out of the reach of children and animals.
- ▶ Keep accumulators and batteries away from chemical, mechanical and thermal influences.
- ▶ Do not recharge old accumulators and batteries.
- ▶ Components of the operator as well as old accumulators and batteries must not be disposed of with household waste. They must be disposed of properly.



NOTE

- Dispose of all components in accordance with local and national regulations to avoid environmental damage.



INFORMATION

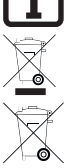

- All components that have been taken out of service, old accumulators and operator batteries must not be disposed of with household waste. Dispose of components which are no longer in use, old accumulators and batteries properly. You must observe the local and national regulations.

17. Short instructions for installation

The short instructions describe the installation of **variants A/B**.

The short instructions do not replace the installation and operating manual. Read this Installation and Operating Manual carefully and, most importantly, observe all warnings and safety instructions. This will ensure that you can install the product safely and optimally.

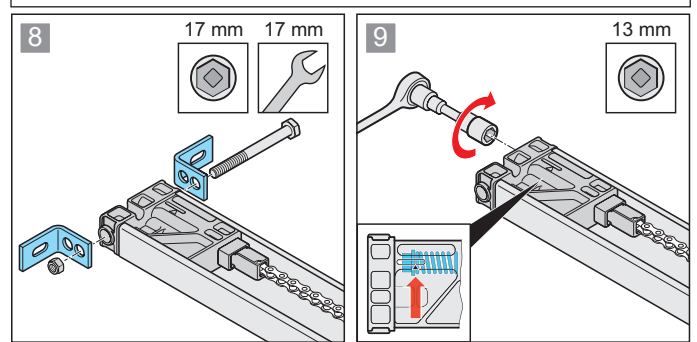
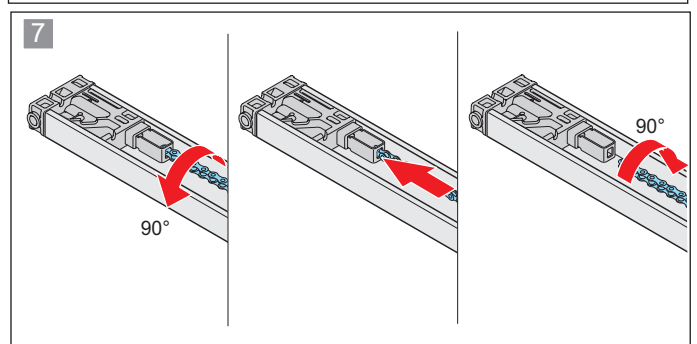
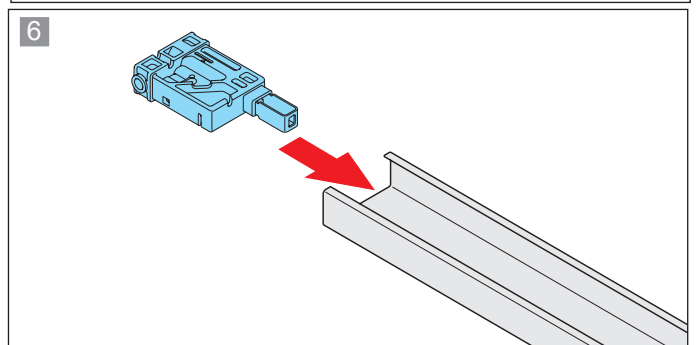
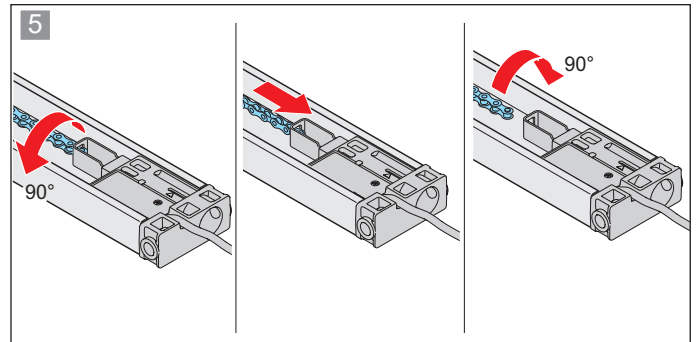
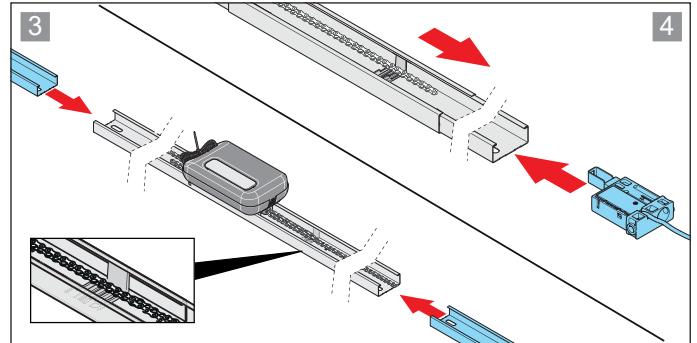
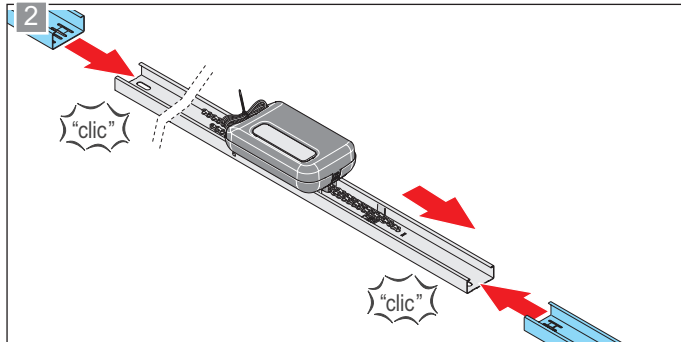
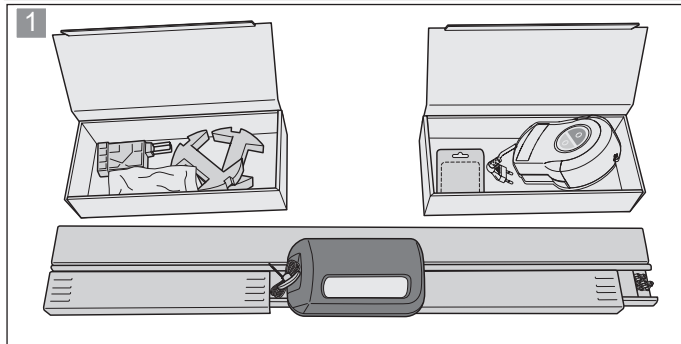
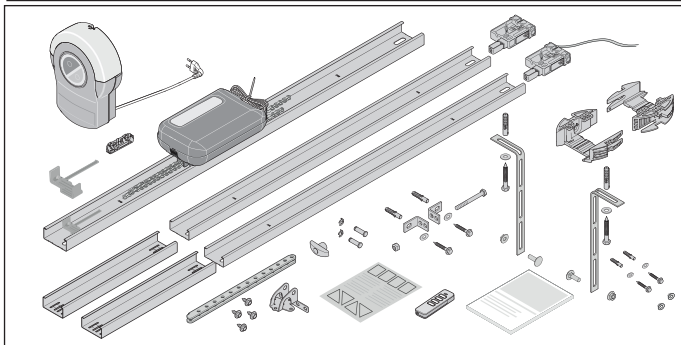
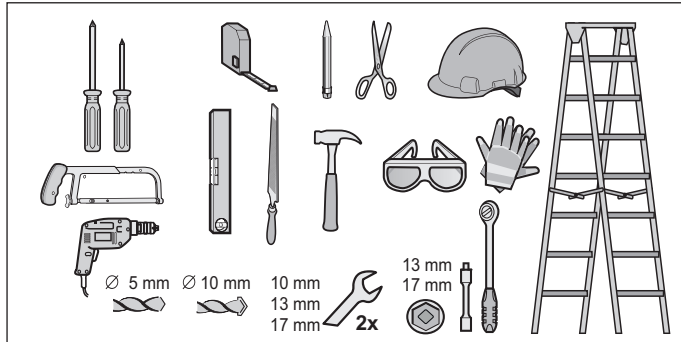
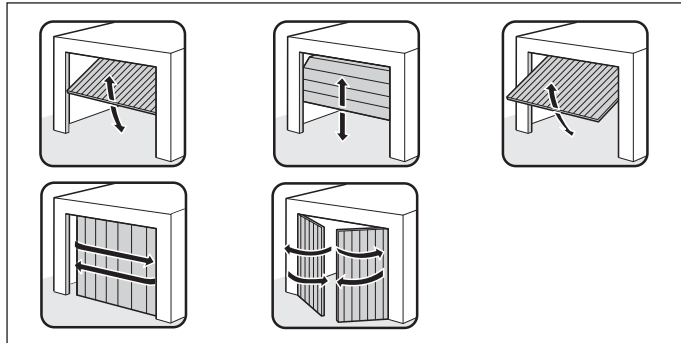

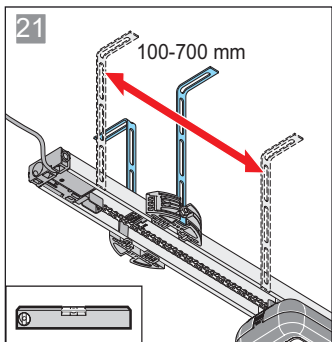
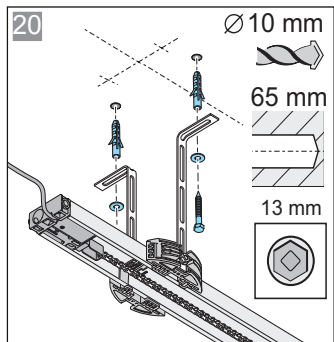
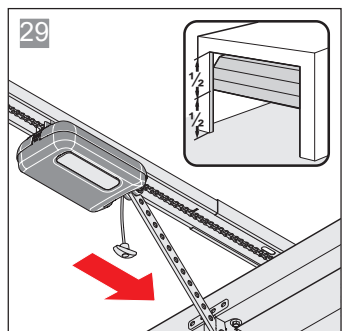
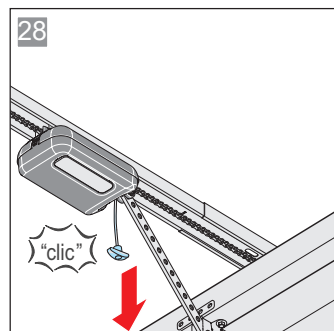
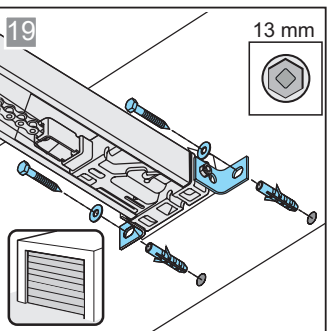
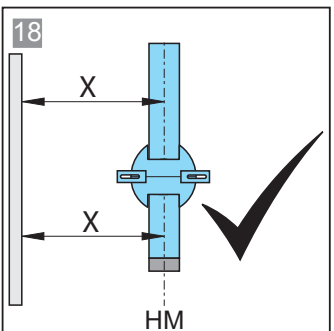
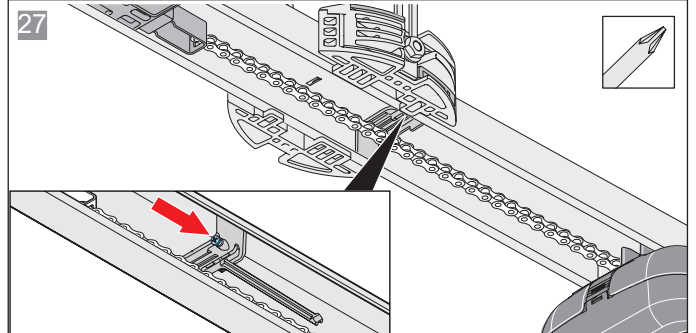
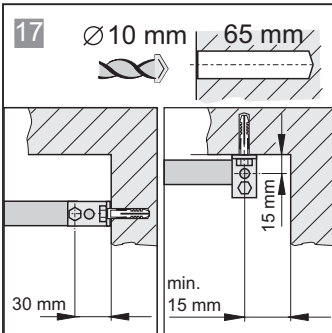
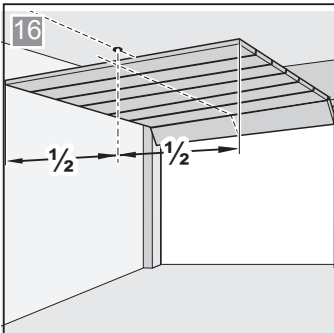
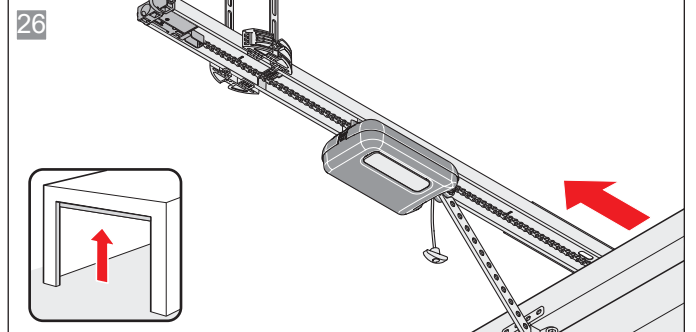
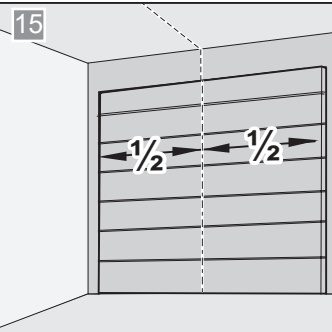
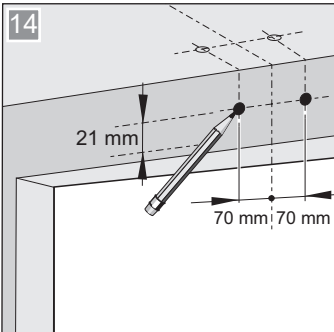
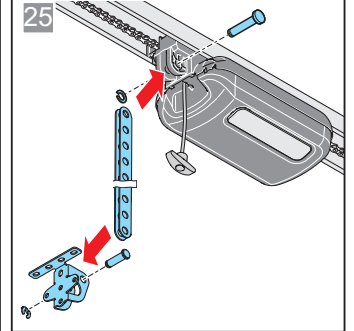
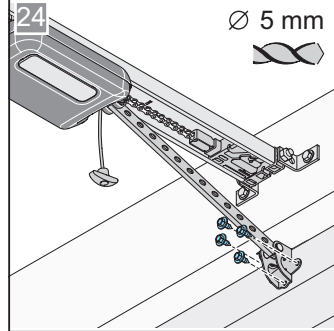
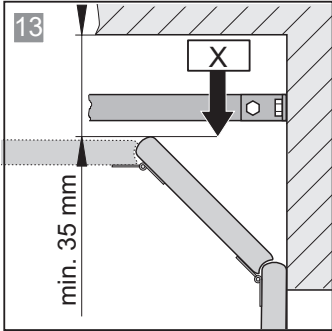
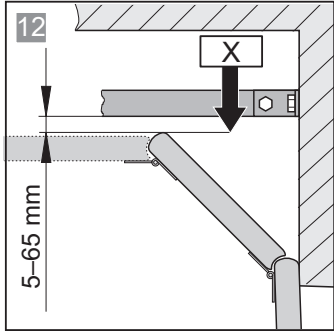
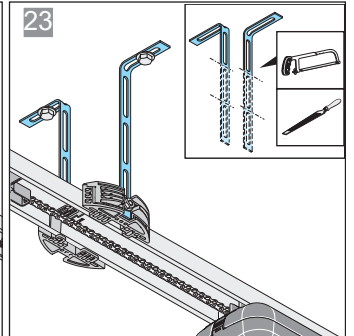
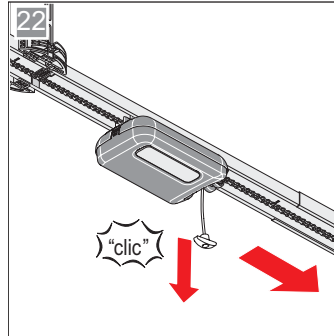
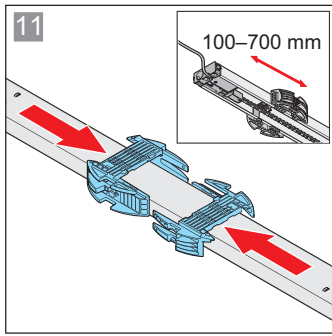
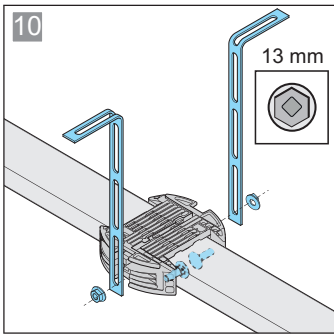

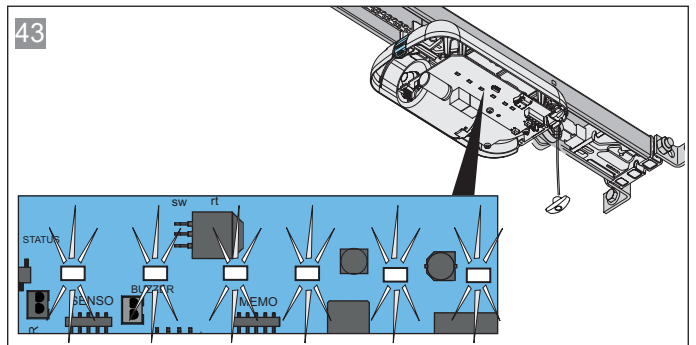
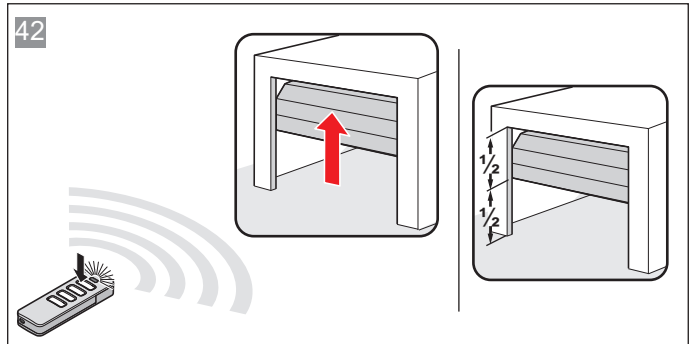
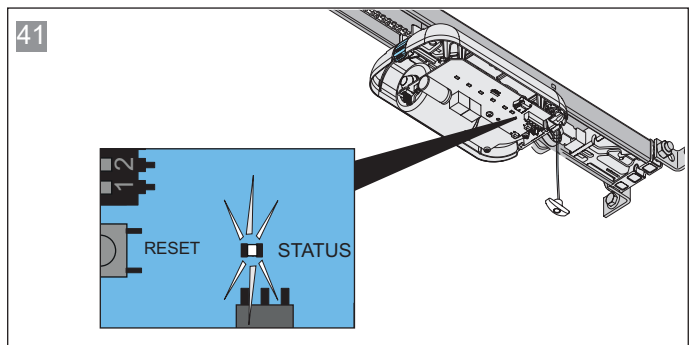
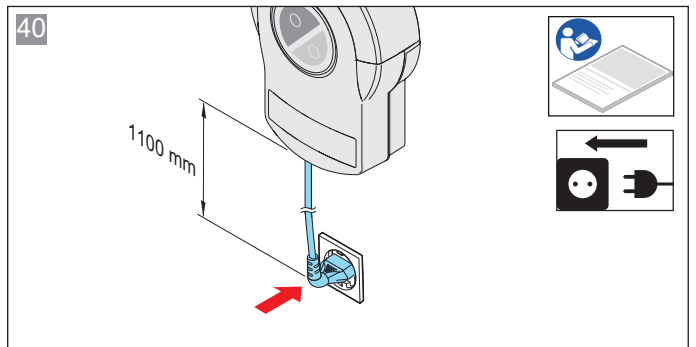
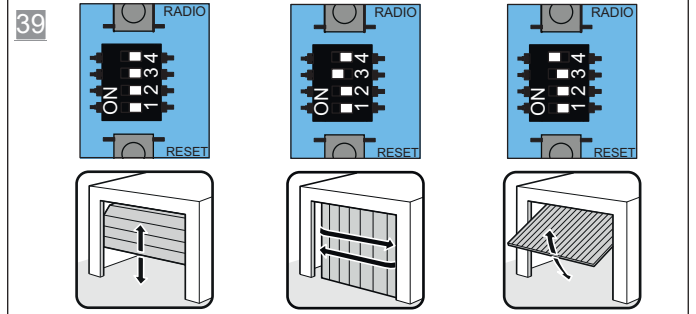
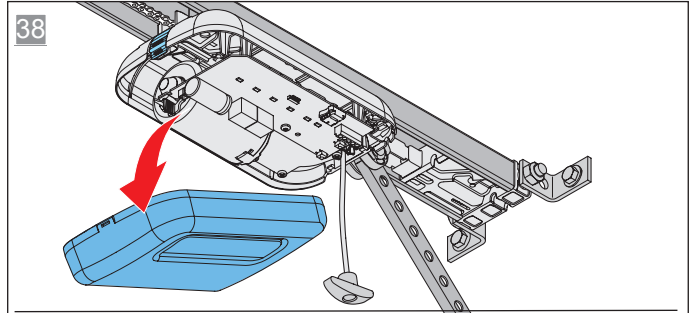
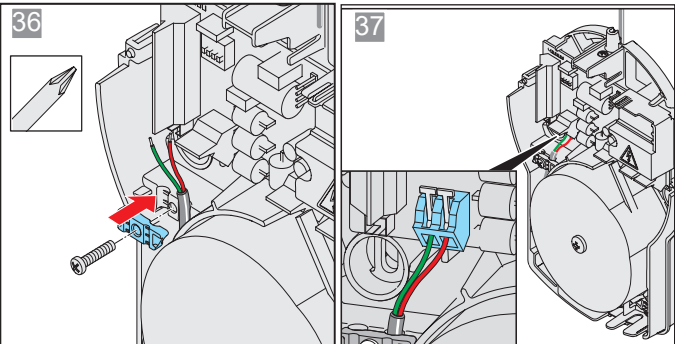
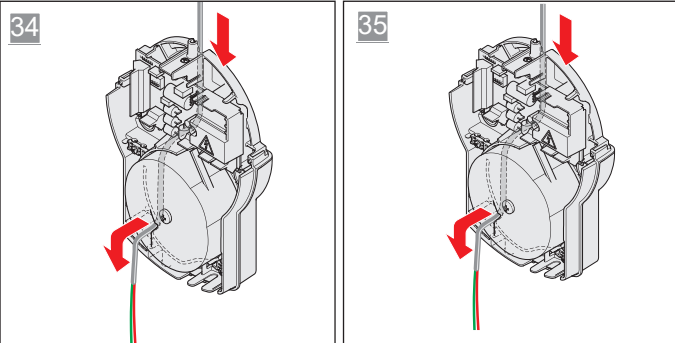
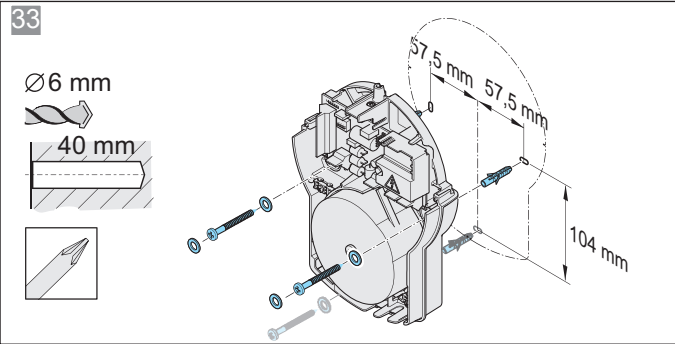
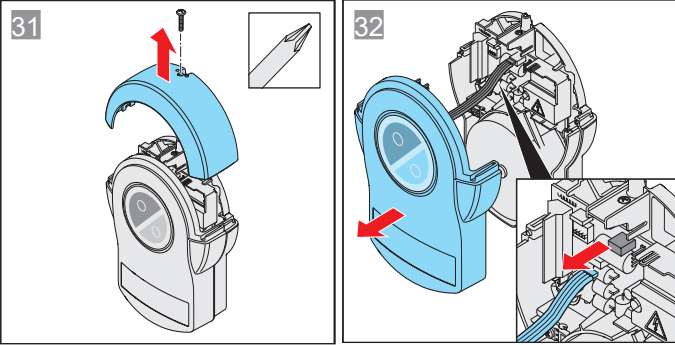
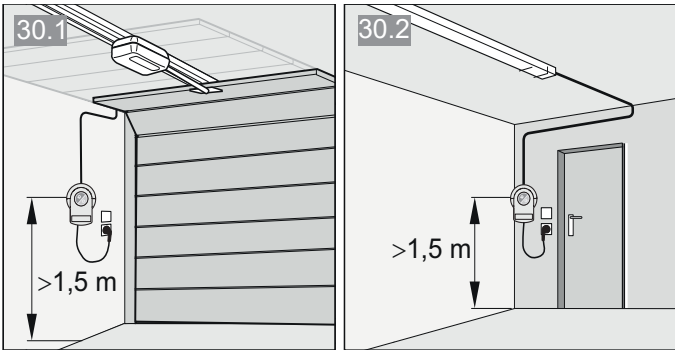

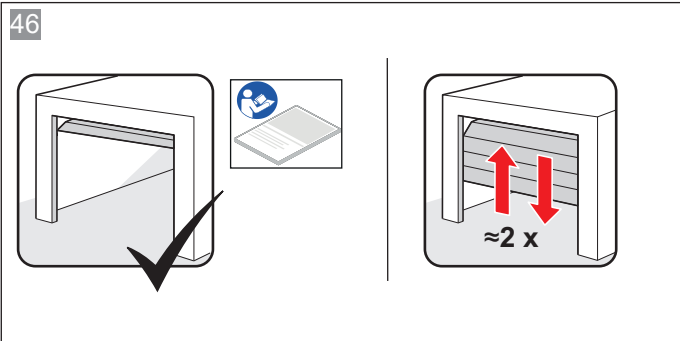
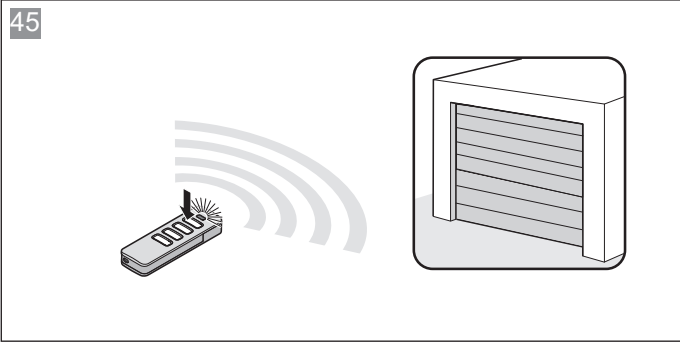
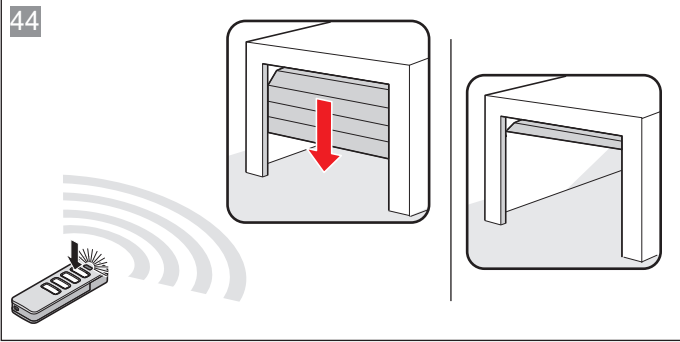

18. Connection diagrams and functions of the DIP switches pro/pro+

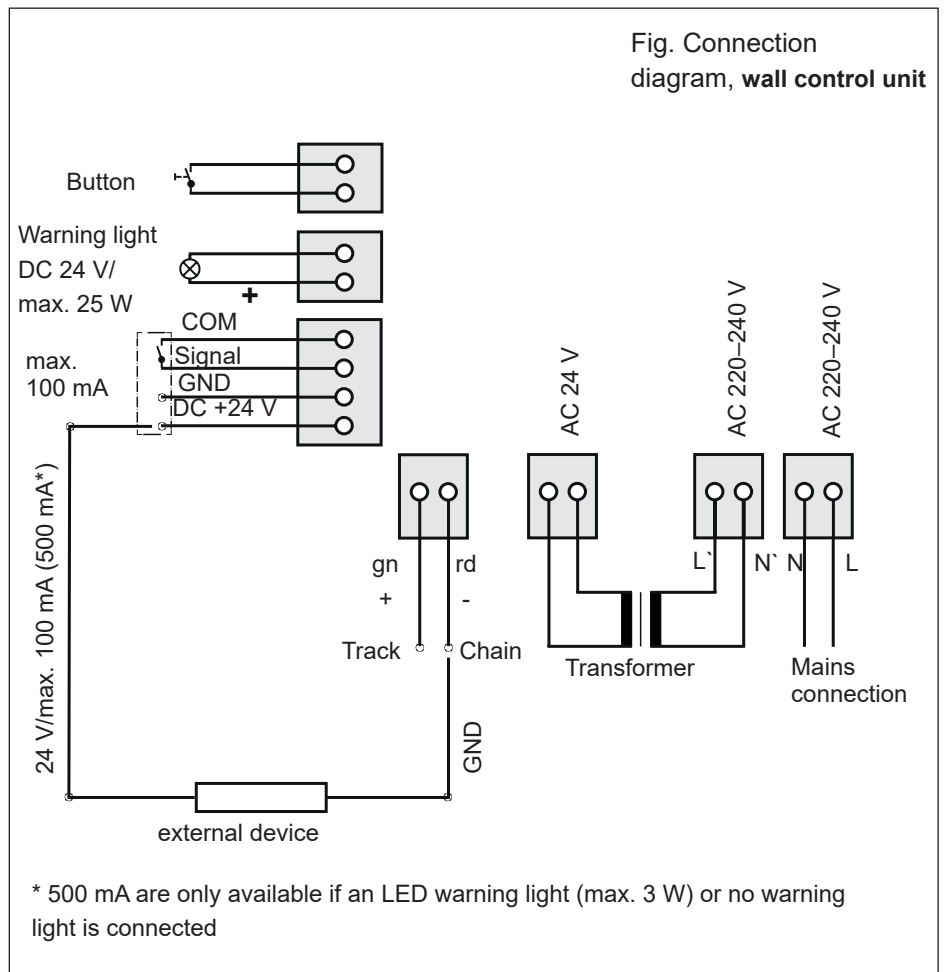
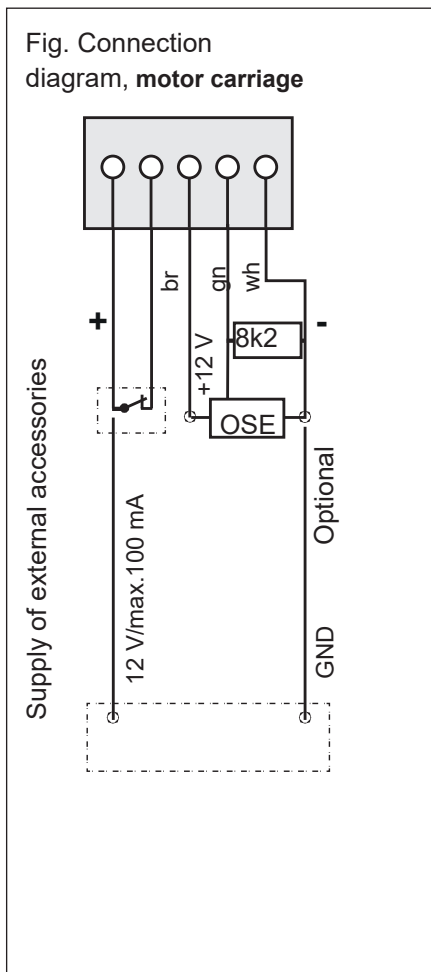

- When connecting external devices, power-saving mode must be deactivated to ensure the power supply.
- The version can vary depending on the type. This means, for example, that the use of accessories can vary.

	ON	OFF	
	• Automatic closing function activated	• Automatic closing function deactivated	
	• Partial opening activated/lighting function deactivated	• Partial opening deactivated/lighting function activated	
	• No function		

	ON	OFF	
	• Membrane keypad/Conex additional circuit board	• Membrane keypad/Conex additional circuit board	
	• Membrane keypad T1 defines door OPEN • Membrane keypad T2 defines door CLOSE	• Membrane keypad T1, pulse sequence • Membrane keypad 2, lighting function/partial opening	
	• Relay (MUFU) trips: during door movement and if the door is not closed*	• Lighting function	
	• Continuous power to the complete system activated	• Power-saving mode activated	
	• COM and Signal activated as button input (partial opening)	• COM and Signal activated as safety contact for photocell	

* e.g.: Door status display

SOMMER Antriebs- und Funktechnik GmbH

Hans-Böckler-Straße 21-27

D-73230 Kirchheim/Teck

Germany



+49 (0) 7021 8001-0



+49 (0) 7021 8001-100

info@sommer.eu

www.sommer.eu