

EN TRANSLATION OF THE ORIGINAL INSTALLATION AND OPERATING MANUAL

## Garage door operator

S 9060 tiga

S 9080 tiga

S 9110 tiga

Download the current manual:



Congratulations on your purchase of a product of **SOMMER Antriebs- und Funktechnik GmbH**.

This product has been developed and manufactured under high standards of quality and with reference to ISO 9001.

Our passion for the product is just as important to us as the needs and requirements of our customers. We place particular emphasis on the safety and reliability of our products.

Read this installation and operating manual carefully and follow all instructions. This will ensure that you can install and operate the product safely and optimally. If you have any questions, please contact your specialist retailer or installer.

All our products are intended for use by persons of all genders, even where this is not specifically stated.

## Warranty

The warranty complies with statutory requirements.

The contact person for warranties is the qualified dealer.

The warranty is only valid in the country in which the operator was purchased. There is no warranty for consumables such as batteries, accumulators and fuses as well as light bulbs.

This also applies for wear parts. The operator is only designed for a limited frequency of use. More frequent use leads to increased wear.

## Contact data

If you require after-sales service, spare parts or accessories, please contact your qualified specialist retailer or installer.

## Feedback on this Installation and Operating Manual

We have tried to make the Installation and Operating Manual as easy as possible to follow. If you have any suggestions as to how we could improve it or if you think more information is needed, please send your suggestions to us:



+49 (0) 7021 8001-403



doku@sommer.eu

## Service

If you require service, please contact us on our service hotline (fee required) or see our web site:



+49 (0) 900 1800-150

[www.sommer.eu/de/kundendienst.html](http://www.sommer.eu/de/kundendienst.html)

## Copyright and proprietary rights

The manufacturer retains the copyright for this Installation and Operating manual. No part of this installation and operating manual may be reproduced in any form without the written permission of **SOMMER Antriebs- und Funktechnik GmbH** or processed, copied, or distributed using electronic systems. Violations of the specifications above will lead to claims for damages. All brands mentioned in this manual are the property of their respective manufacturer and hereby recognised as such.

<b>1. About this Installation and Operating Manual</b>	<b>4</b>
1.1 Storage and circulation of the Installation and Operating Manual	4
1.2 Important for translations	4
1.3 Description of the product type	4
1.4 Target groups of the Installation and Operating Manual	4
1.5 Explanation of symbols and notes	4
1.6 Special warning symbols and mandatory signs	5
1.7 Information regarding the depiction of text	5
1.8 Intended use of the operator	5
1.9 Improper use of the operator	6
1.10 Qualifications of personnel	6
1.11 Information for the user	7
<b>2. General safety instructions</b>	<b>8</b>
2.1 Basic safety instructions for operation	8
2.2 Additional safety information for the radio remote control	9
2.3 Information on operation and on radio remote control	9
2.4 Simplified Declaration of Conformity for radio systems	9
<b>3. Description of function and product</b>	<b>10</b>
3.1 The operator and its mode of operation	10
3.2 Safety equipment	11
3.3 Definitions	11
3.4 Operator response with factory settings	12
3.5 Product designation	13
3.6 Explanation of tool symbols	13
3.7 Scope of delivery	14
3.8 Dimensions	15
3.9 Technical data	15
3.10 Overview of connection options	16
3.11 Door types and accessories	16
<b>4. Tools and protective equipment</b>	<b>17</b>
4.1 Required tools and personal protective equipment	17
<b>5. Declaration of incorporation</b>	<b>17</b>
<b>6. Installation</b>	<b>18</b>
6.1 Important notes and information	18
6.2 Preparing for installation	19
6.3 Installing the drive system	20
6.4 Installing installation variant A or B of the operator system	21
6.5 Installing installation variant C of the operator system	23
6.6 Installation on the door	25
6.7 Installing the wall control unit	28
<b>7. Removing and fastening covers</b>	<b>30</b>
7.1 Cover of the motor carriage	30
7.2 Cover of the wall control unit	30
<b>8. Electrical connection and special functions</b>	<b>31</b>
8.1 Connecting to the mains voltage	31

# Table of contents

<b>9. Initial operation</b>	<b>32</b>	<b>12. Function test/final test</b>	<b>56</b>
9.1 Important notes and information	32	12.1 Testing obstacle detection	56
9.2 Carrying out automatic initial operation	32	12.2 Handover of the door system	57
9.3 Carrying out manual initial operation	34	<b>13. Operation</b>	<b>58</b>
9.4 Detecting obstacles during the force programming run	34	13.1 Important notes and information	58
9.5 Mechanical adjustment of the end positions	35	13.2 Handover to the user	58
9.6 Attaching information sign and warning signs	36	13.3 Operating modes of door movement	59
<b>10. Connections and special functions of the motor carriage</b>	<b>37</b>	13.4 Performing obstacle detection	61
10.1 Motor carriage circuit board	37	13.5 Power-saving mode	62
10.2 Connection options on the motor carriage	38	13.6 In the event of a power failure	62
10.3 Reducing the illumination power of LEDs	39	13.7 Function of the emergency release	62
10.4 Explanation of the radio channels	39	<b>14. Maintenance and care</b>	<b>64</b>
10.5 Programming the transmitter	39	14.1 Important notes and information	64
10.6 Information on Memo	40	14.2 Maintenance schedule	65
10.7 Cancelling programming mode	40	14.3 Care	65
10.8 Deleting a transmitter button from the radio channel	40	<b>15. Troubleshooting</b>	<b>66</b>
10.9 Deleting a transmitter completely from the receiver	40	15.1 Important notes and information	66
10.10 Deleting a radio channel in the receiver	41	15.2 Preparing for troubleshooting	67
10.11 Deleting all radio channels in the receiver	41	15.3 Time sequences of operator lighting in normal mode and in case of faults	68
10.12 Programming a second handheld transmitter by radio (HFL)	41	15.4 Troubleshooting table	69
10.13 Carrying out a reset	42	15.5 Replacing the motor carriage	71
10.14 Setting the DIP switches on the motor carriage	42	<b>16. Taking out of operation, storage and disposal</b>	<b>72</b>
10.15 Setting the automatic closing function	42	16.1 Important notes and information	72
10.16 Hold open time	43	16.2 Taking out of operation and disassembly	72
10.17 Setting the hold open time manually	43	16.3 Storage	72
10.18 Pre-warning time	44	16.4 Disposal of waste	73
10.19 Priority switching	44	<b>17. Brief instructions for installation</b>	<b>74</b>
10.20 Shortened hold open time for driving through the photocell	44	<b>18. Connection diagrams and functions of the DIP switches for tiga</b>	<b>78</b>
10.21 Clearing time	44		
10.22 12 V output	44		
10.23 Setting partial opening	44		
10.24 Deleting partial opening	45		
10.25 Wicket door safety device	45		
10.26 Connecting the safety contact strip	45		
10.27 SOMlink	45		
<b>11. Connections and special functions of the wall control unit</b>	<b>46</b>		
11.1 Wall control unit circuit board	46		
11.2 Connection options to the wall control unit	48		
11.3 Setting DIP switches on the wall control unit	50		
11.4 Information on Memo tiga	50		
11.5 Multi-function relay 1 – MUFU 1	51		
11.6 Relay	52		
11.7 Photocell and frame photocell	52		
11.8 Connecting the light curtain	53		
11.10 STOP connection	54		
11.11 Installing and removing the battery pack	54		

# 1. About this Installation and Operating Manual

## 1.1 Storage and circulation of the Installation and Operating Manual

Read this Installation and Operating Manual carefully and completely before installation, commissioning and operation and also before removal. Observe all warnings and safety instructions.

Keep this Installation and Operating Manual accessible to all users at all times at the place of use. A replacement for the installation and operating manual can be downloaded from **SOMMER** at:

[www.sommer.eu](http://www.sommer.eu)

During the transfer or resale of the operator to third parties, the following documents must be passed on to the new owner:

- EC Declaration of Conformity
- handover protocol and inspection book
- this Installation and Operating Manual
- proof of regular maintenance, testing and care
- documents recording retrofitting and repairs

## 1.2 Important for translations

The original installation and operating manual was written in German. The other available languages are translations of the German version. You can get the original Installation and Operating Manual by scanning the QR code.



<https://som4.me/orig-tiga-reve>

For other language versions, see:  
[www.sommer.eu](http://www.sommer.eu)

## 1.3 Description of the product type

The operator has been constructed according to state-of-the-art technology and recognised technical regulations and is subject to the Machinery Directive 2006/42/EC.

The operator is fitted with a radio receiver. Optionally available accessories are also described.

The version can vary depending on the type. This means the use of accessories can vary.

## 1.4 Target groups of the Installation and Operating Manual

The installation and operating manual must be read and observed by everyone assigned with one of the following tasks or using the device:

- unloading and in-house transport
- unpacking and installation
- initial operation
- setting
- usage
- maintenance, testing and care
- troubleshooting and repairs
- disassembly and disposal

## 1.5 Explanation of symbols and notes

The warnings in this installation and operating manual are structured as follows.

### Signal word



Hazard symbol

#### Type and source of hazard

Consequences of the hazard

- ▶ Preventing/avoiding the hazard

The hazard symbol indicates the hazard. The signal word is linked to a hazard symbol. The hazard is classified into three classes depending on its danger:

**DANGER**

**WARNING**

**CAUTION**

There are three different classifications of hazards.

### **DANGER**



**Describes an immediate danger that leads to serious injury or death**

Describes the consequences of the danger to you or other persons.

- ▶ Follow the instructions for avoiding or preventing the danger.

### **WARNING**



**Describes a potential danger that may lead to fatal or serious injury**

Describes the possible consequences of the danger to you or other persons.

- ▶ Follow the instructions for avoiding or preventing the danger.

### **CAUTION**



**Describes a potential danger of a hazardous situation.**

Describes the possible consequences of the danger to you or other persons.

- ▶ Follow the instructions for avoiding or preventing the danger.

# 1. About this Installation and Operating Manual

The following symbols are used for notes and information:



## NOTE

- Describes additional information and useful notes for correct use of the operator without endangering persons.
  - If it is not observed, property damage or faults in the operator or door may occur.



## INFORMATION

Describes additional information and functions for optimum use of the operator.

The following symbols are used in the figures and text.



Continue reading the Installation and Operating Manual for more information.



Disconnect the operator from the mains voltage



Connect the operator to the mains voltage



Factory setting



Connection via SOMlink to a WiFi-enabled device



Symbol refers to a period of time, e.g. 60 seconds.



Operator components must be disposed of properly



Old accumulators and batteries must be disposed of properly

## 1.6 Special warning symbols and mandatory signs

To specify the source of danger more precisely, the following symbols are used together with the above-mentioned hazard symbols and signal words. Follow the instructions to prevent a potential hazard.



**Danger due to electric current!**



**Danger of falling!**



**Danger due to falling parts!**



**Danger of entrapment!**



**Danger of crushing and shearing!**



**Danger of tripping and falling!**



**Danger due to optical radiation!**

The following mandatory signs are used for the respective actions. The requirements described must be complied with.



**Wear personal safety glasses**



**Wear a personal safety helmet**



**Wear personal safety gloves**

## 1.7 Information regarding the depiction of text

1. Stands for directions for an action

⇒ Stands for the results of the action

Lists are shown as a list of actions:

- List 1
- List 2

1, A Item number in the figure refers to a number in the text.



Important text items, for example in directions for actions, are emphasised in **bold** type.

References to other chapters or sections are in **bold** type and set in “**quotation marks**”.

## 1.8 Intended use of the operator

The operator is intended exclusively to open and close doors. Any other use does not constitute intended use. The manufacturer accepts no liability for damage resulting from use other than the intended use. The user bears the sole responsibility for any risk involved. It also voids the warranty.

Any changes to the operator must be made with original accessories from **SOMMER** only and only to the extent described. For more information on accessories, see:



<https://downloads.sommer.eu/>

# 1. About this Installation and Operating Manual

Doors automated with this operator must comply with all valid international and domestic standards, directives and regulations in their currently valid version. These include EN 12604 and EN 13241.

The operator may only be used:

- in combination with door types in the reference list which can be found at:



<https://som4.me/cgdo>

- if the EC Declaration of Conformity has been issued for the door system
- if the CE mark and the type plate for the door system have been attached to the door
- if the handover protocol and the inspection book have been completed and are available
- if the installation and operating manuals for the operator and the door are present
- as specified in this Installation and Operating Manual
- in good technical condition
- with attention to safety and hazards by trained users.

After installation of the operator, the person responsible for the installation of the operator must complete an EC Declaration of Conformity for the door system in accordance with Machinery Directive 2006/42/EC and apply the CE mark and a type plate to the door system. This also applies if the operator is retrofitted to a manually operated door. In addition, a handover protocol and an inspection book must be completed.

The following are available:

- EC Declaration of Conformity
- handover protocol for the operator



<https://som4.me/konform>

## 1.9 Improper use of the operator

Any other use or additional use that has not been described in Chapter 1.8 constitutes improper use. The user bears the sole responsibility for any risk involved.

The manufacturer's warranty will be voided by:

- damage caused by other use and improper use
- use with defective parts
- unauthorised modifications to the operator
- modifications and non-approved programming of the operator and its components

The door must not be part of a fire protection system, an escape route or an emergency exit that automatically closes the door in the event of fire. Installation of the operator will prevent automatic closing.

Observe the local building regulations.

The operator may not be used in:

- areas with explosion hazard
- very salty air
- aggressive atmosphere, including chlorine

## 1.10 Qualifications of personnel

### Qualified specialist for installation, commissioning and disassembly

This Installation and Operating Manual must be read and complied with by a **qualified specialist** who installs or performs maintenance on the operator.

Work on the electrical system and live parts must be performed by a **trained electrician** in accordance with EN 50110-1.

The installation, initial operation and disassembly of the operator may only be performed by a qualified specialist. A qualified specialist is a person commissioned by the installer.

The **qualified specialist** must be familiar with the following standards:

- EN 13241 Doors and gates – Product standard
- EN 12604 Doors and gates – Mechanical aspects – Requirements and test methods
- EN 12453: Safety in use of power-operated doors 2017 (Plc)

When all work has been completed, the **qualified specialist** must:

- issue an EC Declaration of Conformity
- attach the CE mark and the type plate to the door system

# 1. About this Installation and Operating Manual

---

## Instructing the user and handover of documents

The **qualified specialist** must instruct the user:

- on the operation of the operator and its dangers
- on the handling of the manual emergency release
- on regular maintenance, testing and care which the user can carry out.

The qualified specialist must inform the user which work may only be carried out by a qualified specialist:

- installation of accessories
- settings
- regular maintenance, testing and care
- troubleshooting

### 1.11 Information for the user

The user must ensure that the CE mark and the type plate have been attached to the door system.

The following documents for the door system must be handed over to the user:

- EC Declaration of Conformity
- handover protocol and inspection book
- the installation and operating manuals for the operator and the door

The user is responsible for:

- keeping this Installation and Operating Manual accessible at all times at the place of use
- the intended use of the operator
- its good condition
- instructing all users how to use the operator, the hazards involved and in the operation of the emergency release
- operation
- regular maintenance, testing and care
- troubleshooting

The operator must not be used by persons with restricted physical, sensory or mental capacity or who lack experience and knowledge. All users must be specially instructed and have read and understood the Installation and Operating Manual.

Children must never play with or use the operator, even under supervision. Children must be kept clear of the operator. Handheld transmitters or other command devices must never be given to children. Handheld transmitters must be safely stored and protected against unintended and unauthorised use.

The user must observe the accident prevention regulations and the applicable standards. The guideline "Technical regulations for workplaces ASR A1.7" of the German committee for workplaces (ASTA) is applicable for commercial use. The guidelines described must be observed and complied with. In other countries, the user must comply with the applicable national regulations.

## 2. General safety instructions

### 2.1 Basic safety instructions for operation

Follow the basic safety instructions listed below.

---

#### **Danger if not observed!**

If safety instructions are not observed, serious injury or death may result.

- ▶ All safety instructions must be complied with.

---

#### **Danger due to electric current!**

Contact with live parts may result in electric current flowing through the body. Electric shock, burns or death will result.

- ▶ Installation, testing and replacement of electrical components must be carried out by a **trained electrician**.
- ▶ Disconnect the mains plug before working on the operator.
- ▶ If a battery pack is connected, disconnect it from the control unit.
- ▶ Check that the operator is not live.
- ▶ Secure the operator against being switched back on.

---

#### **Danger due to use of the operator with incorrect settings or when it is in need of repair!**

If the operator is used despite incorrect settings or if it is in need of repair, severe injury or death may result.

- ▶ The operator may only be used with the required settings and in the proper condition.
- ▶ You must have faults repaired professionally without delay.

---

#### **Danger of hazardous substances!**

Improper storage, use or disposal of battery packs, batteries and operator components pose a risk to the health of humans and animals. Serious injury or death may result.

- ▶ Battery packs and batteries must be stored out of the reach of children and animals.
- ▶ Keep battery packs and batteries away from chemical, mechanical and thermal influences.
- ▶ Do not recharge old accumulators and batteries.
- ▶ Components of the operator as well as old accumulators and batteries must not be disposed of with household waste. They must be disposed of properly.

---

#### **Danger for trapped persons!**

Persons may be trapped inside the garage. If trapped persons cannot free themselves, severe injury or death may result.

- ▶ Check the function of the emergency release at monthly intervals, **particularly** from inside in the door CLOSE end position and if necessary, also from outside.
- ▶ You must have faults repaired professionally without delay.

---

#### **Danger due to falling parts of doors!**

Actuating the emergency release can lead to uncontrolled door movement if

- springs are weakened or broken.
- the door has not been optimally weight-balanced.

Falling parts may cause a hazard. Severe injuries or death may result.

- ▶ Check the weight balance of the door at regular intervals.
  - ▶ Pay attention to the movement of the door when the emergency release is actuated.
  - ▶ Keep clear of the movement area of the door.
- 

---

#### **Danger of entrapment!**

Persons or animals in the movement area of the door may be trapped and pulled along with the door. Severe injuries or death may result.

- ▶ Keep clear of the movement area of the door.

---

#### **Danger of crushing and shearing!**

If the door moves and there are persons or animals in the movement area, crushing and shearing injuries may be caused by the mechanism and safety edges of the door.

- ▶ Only use the operator when you have a direct view of the door.
- ▶ All danger zones must be visible during the entire door operation.
- ▶ Always keep the moving door in sight.
- ▶ Keep persons and animals clear of the range of movement of the door.
- ▶ Never put your hand near the door when it is moving or near moving parts. In particular, do not reach into the moving push arm.
- ▶ Do not reach into the ceiling suspension unit when the motor carriage is running along the rail.
- ▶ Do not drive through the door until it has opened completely.
- ▶ Store the handheld transmitter so that unauthorised or accidental operation, e.g., by children or animals, is impossible.
- ▶ Never stand under the opened door.

---

#### **Danger due to optical radiation!**

Looking into an LED at short range for an extended period may cause optical glare. This may temporarily reduce vision. This may cause serious or fatal accidents.

- ▶ Never look directly into an LED.

---

#### **Risk of eye injury!**

Chips flying when drilling may cause serious injuries to eyes and hands.

- ▶ Wear safety glasses when drilling.

---

#### **Risk of injury in the head region**

Impact with suspended objects may cause serious abrasions and cuts.

- ▶ You must wear a safety helmet when installing suspended parts.

---

#### **Risk of injury to hands!**

Rough metal parts may cause abrasions and cuts when picked up or touched.

- ▶ Wear safety gloves when deburring or performing similar work.
-



## 2. General safety instructions

### 2.2 Additional safety information for the radio remote control

Follow the basic safety instructions listed below.

#### **Danger of crushing and shearing!**

If the door is not visible and the radio control is operated, crushing and shearing injuries to persons or animals may be caused by the mechanism and safety edges of the door.

- ▶ In particular when operating control elements such as the radio control, all danger zones must be visible during the entire door operation.
- ▶ Always keep the moving door in sight.
- ▶ Keep persons and animals clear of the range of movement of the door.
- ▶ Never put your hand near the door when it is moving or near moving parts.
- ▶ Do not drive through the door until it has opened completely.
- ▶ Store the handheld transmitter so that unauthorised or accidental operation, e.g., by children or animals, is impossible.
- ▶ Never stand under the opened door.

### 2.3 Information on operation and on radio remote control

The user of the radio system is not protected against interference due to other telecommunications equipment or devices. This includes radio-controlled systems that are licensed to operate in the same frequency range. If significant interference occurs, please contact your appropriate telecommunications office which has radio interference measuring equipment or radio location equipment.

#### **NOTE**

- Dispose of all components in accordance with local and national regulations to avoid environmental damage.
- The motor carriage is supplied with safety low voltage via the chain and the rail.  
The use of oil or grease will greatly reduce the conductivity of the chain, rail and motor carriage. This may result in faults due to inadequate electrical contact. The chain and rail are maintenance-free and must not be oiled or greased.
- Objects in the movement area of the door may be jammed and damaged.  
Objects must not be in the range of movement of the door.
- If the door is not in view and the radio remote control is actuated, objects in the movement area of the door may be jammed and damaged.  
Objects must not be in the range of movement of the door.



#### **INFORMATION**



- Operator components that have been taken out of service as well as old accumulators and batteries must not be disposed of with household waste. Dispose of components which are no longer in use, old accumulators and batteries properly. You must observe the local and national regulations here.

### 2.4 Simplified Declaration of Conformity for radio systems

**SOMMER Antriebs- und Funktechnik GmbH** hereby declares that the radio system (tiga and tiga+) complies with Directive 2014/53/EU. The full text of the EU Declaration of Conformity for the radio system can be found at:



<https://som4.me/konform-funk>

### 3. Description of function and product

#### 3.1 The operator and its mode of operation

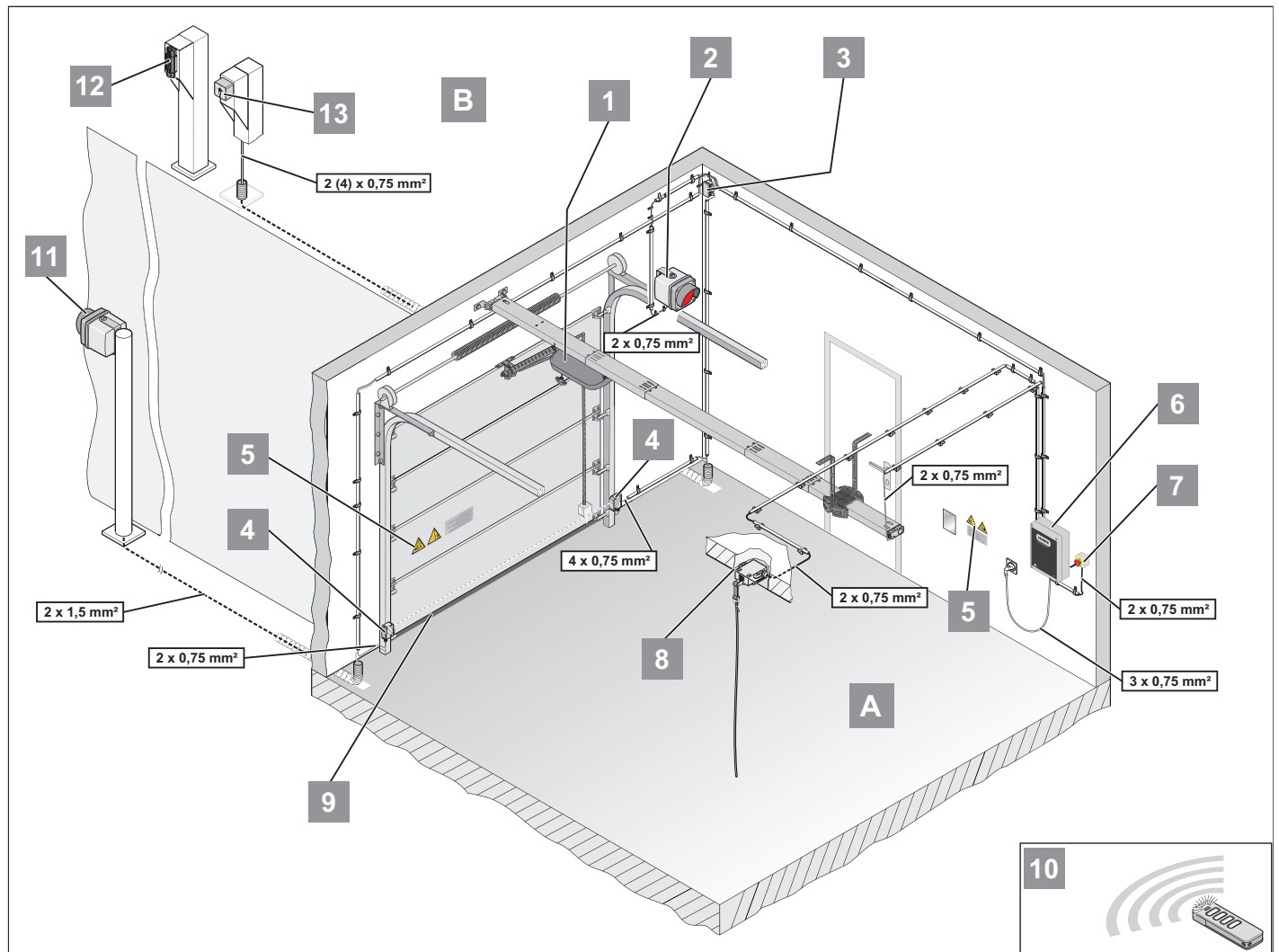

Fig. Door structure with operator

#### **A** Interior side

- 1) Motor carriage
- 2) Red traffic light, interior
- 3) Junction box
- 4) Photocell
- 5) Warning sticker
- 6) Control unit
- 7) EMERGENCY STOP
- 8) Pull button
- 9) Safety contact strip
- 10) Handheld transmitter

#### **B** Exterior side

- 11) Red traffic light, exterior
- 12) Key switch
- 13) Telecody

Sectional doors and other types of doors can be opened and closed with the electrically powered operator and its available accessories. The operator can be controlled with a handheld transmitter. The rail is mounted on the ceiling and the lintel above the garage door. The motor carriage is attached to the door by a push arm. The motor carriage moves along the rail on a spring-mounted chain and opens or closes the door. Access authorisation for the interior and exterior is displayed by the traffic lights. The handheld transmitter can be stored in a holder in the vehicle.

## 3. Description of function and product

### 3.2 Safety equipment

The operator stops and reverses slightly if it encounters an obstacle. This prevents injury and damage to property. The door will be partially or completely opened, depending on the setting.

In the event of a power failure, the door can be opened from the inside via an emergency release handle or from the outside with a Bowden wire or emergency release lock.

### 3.3 Definitions

#### Programming

The operator programs the path and force required to open and close the door. The operator saves these values. The values are saved even if the voltage supply fails.

#### Door OPEN

The door opens or is open.

#### Door CLOSE

The door closes or is closed.

#### Interior (IN)

This side is inside the garage.

#### Exterior (OUT)

This side is outside the garage.

#### Light signal of the traffic lights

Access authorisation for the interior and exterior is displayed by the traffic lights.

#### Request side, interior or exterior

A command was given from this side.

#### Opposite side

This side is opposite the request side.

#### Command from the interior

Button or radio signal give a command to open the door from the interior. After the pre-warning time and, if applicable, the clearing time, the red traffic light for the interior switches off. This gives the authorisation for drive-through from the interior. The red phase is displayed on the opposite side.

#### Command from the exterior

Button or radio signal give a command to open the door from the exterior. If the door is closed or is in the door OPEN end position, the red traffic light for the exterior switches off. This gives the authorisation for drive-through from the exterior. The red phase is displayed on the opposite side.

#### Pre-warning time

This phase affects the time before opening or closing. The traffic light blinks red on both sides. The warning light and the operator lighting of the motor carriage also blink. This announces the operator movement. The door area must be cleared.

#### Hold open time

The door remains open in this phase. The traffic light of the request side is off. The traffic light lights up red on the opposite side. The door can only be opened but not closed by a command from a button or handheld transmitter. While the door is being opened, it cannot be stopped by a command.

#### Example:

If a command is sent while the operator is closing automatically, it opens completely and the hold open time is reset.

#### Clearing time

This phase affects the time after the hold open time has run out. The traffic light lights up red on both sides. The operator lighting of the motor carriage also blinks. This announces movement of the operator or traffic light switch-over for changing the drive-through direction. The door area must be cleared.

#### Multi-function relay – MUFU

The multi-function relay is a relay with a floating changeover contact. The multi-function relay can be configured for several settings using the SOMlink, a WiFi-enabled device and the Memo tiga, with a Memo tiga attached to the SOMlink.

### 3. Description of function and product

#### 3.4 Operator response with factory settings

##### Response after power connection

The door is closed and the operator is programmed. All traffic lights are off. The first direction is always door OPEN. If the door is already open, the operator detects this. After a command to the operator, the command side is granted access authorisation.

The operator closes the door after the hold open time and clearing time run out.

##### Sequence after a command from the interior or exterior, door CLOSE

The traffic lights give the respective light signals for access authorisation.

1. Command from interior or exterior.
  - ⇒ Door opens.  
**Both sides:** Red phase – no authorisation for drive-through.
  - ⇒ Door is open.
  - ⇒ Hold open time starts.  
**Request side:** Green phase – authorisation for drive-through.  
**Opposite side:** Red phase – no authorisation for drive-through.
  - ⇒ Hold open time set at factory runs out.
  - ⇒ Clearing time for door CLOSE starts.  
The operator lighting LEDs blink:  
**Both sides:** Red phase – no authorisation for drive-through.
  - ⇒ Door closes.  
**Both sides:** Red phase – no authorisation for drive-through.
  - ⇒ Door is closed.  
**Both sides:** Traffic lights off.

##### Response after a request from the interior and an additional request from the exterior

1. Command from the interior and subsequent command from the exterior.
  - ⇒ Door opens.  
**Both sides:** Red phase – no authorisation for drive-through.
  - ⇒ Door is open.
  - ⇒ Hold open time starts.  
**Request side, interior:** Green phase – authorisation for drive-through.  
**Opposite side, exterior:** Red phase – no authorisation for drive-through.
  - ⇒ Hold open time set at the factory for the command from the interior runs out.
  - ⇒ Clearing time starts.  
The operator lighting LEDs blink.  
**Both sides:** Red phase – no authorisation for drive-through.
2. Command from the exterior is initiated.  
The request and opposite sides are exchanged here.
  - ⇒ Hold open time starts.  
**Request side, exterior:** Green phase - authorisation for drive-through.  
**Opposite side, interior:** Red phase - no authorisation for drive-through.
  - ⇒ Hold open time set at factory runs out.
  - ⇒ Clearing time for door CLOSE starts.  
The operator lighting LEDs blink:  
**Both sides:** Red phase - no authorisation for drive-through.
  - ⇒ Door closes.  
**Both sides:** Red phase - no authorisation for drive-through.
  - ⇒ Door is closed.  
**Both sides:** Traffic lights off

### 3. Description of function and product

#### 3.5 Product designation

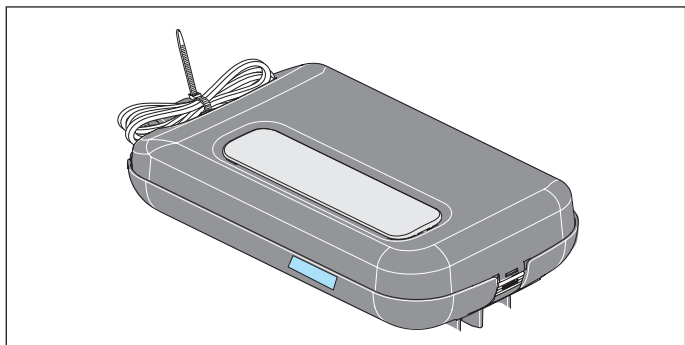

Fig. Motor carriage with type plate and device specifications

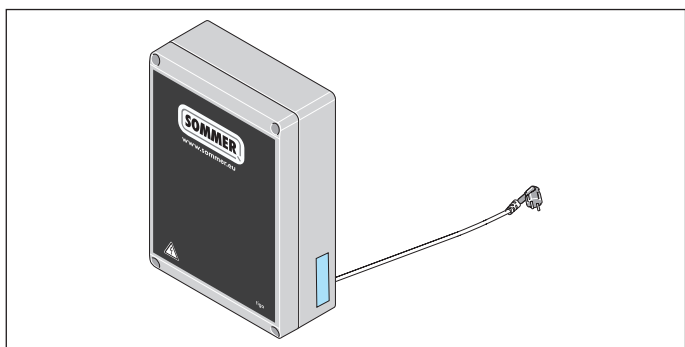

Fig. Control unit with type plate and device specifications

The type plate includes:

- type designation
- Item Number
- date of manufacture with month and year
- serial number

In case of questions or service, please supply the type designation, the date of manufacture and the serial number.

#### 3.6 Explanation of tool symbols

##### Tool symbols

These symbols refer to the use of tools required for installation.



Phillips screwdriver



Metal drill 5 mm



Masonry drill 6/10 mm



Fork wrench 17 mm



Ratchet wrench 13/17 mm

##### Other symbols



Drilling depth



Audible engaging or clicking noise

### 3. Description of function and product

#### 3.7 Scope of delivery

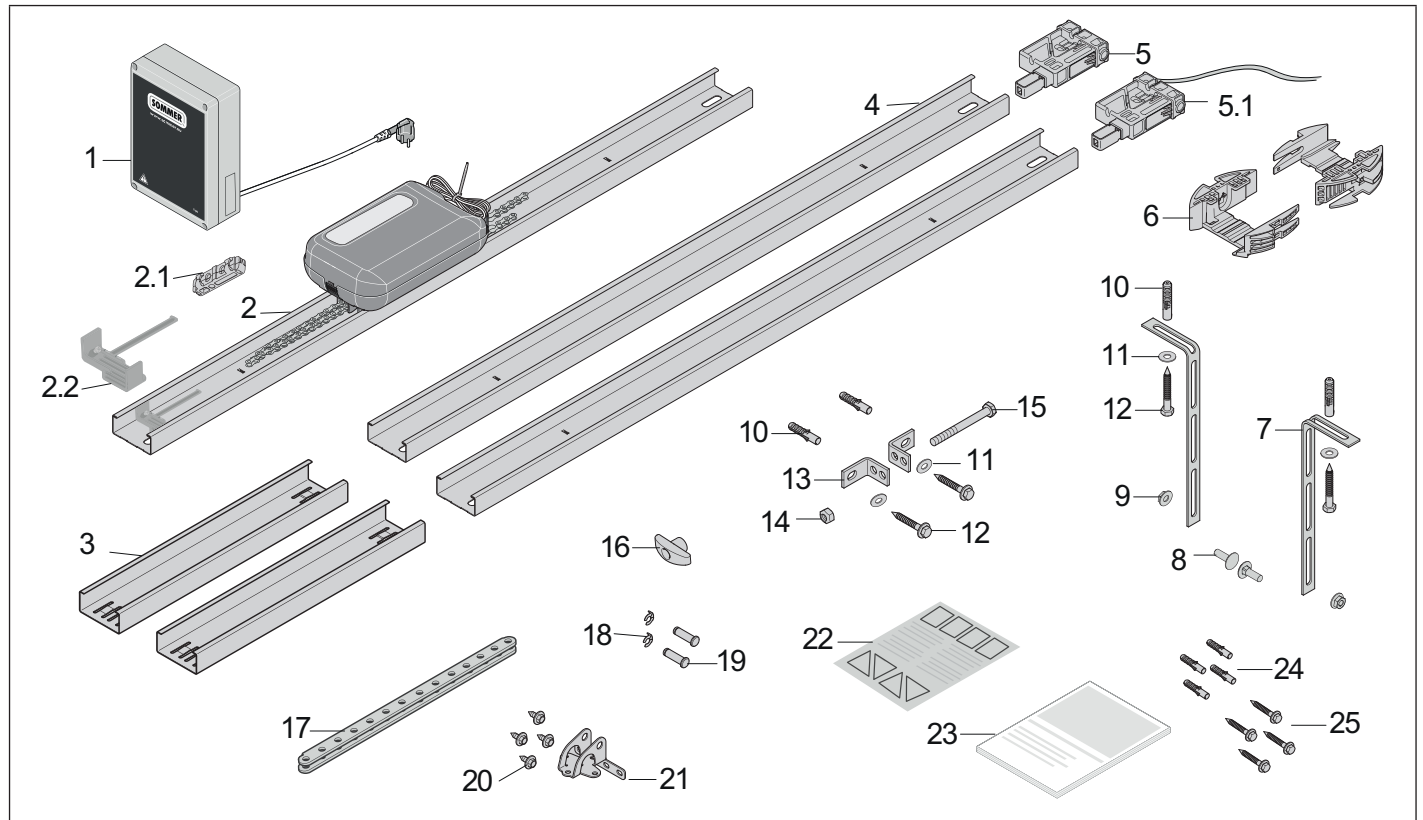

Fig. Scope of delivery

- 1) Wall control unit with Memo tiga, attached at the factory, and power cord
- 2) Rail, **pre-assembled with 1x limit stop**, chain and motor carriage
- 2.1) Isolator, **pre-assembled on the chain** (centre)
- 2.2) Limit stop, **pre-assembled on the rail**
- 3) Connecting sleeve, 2x
- 4) Rail, 2x
- 5) Plug-in unit, **pre-assembled**
- 5.1) Plug-in unit, **pre-assembled**, with control cable, 2-wire, approx. 5 m
- 6) Ceiling holder, 2-part
- 7) Perforated strip, angled, 2x
- 8) Screw M8 x 20 mm, 2x
- 9) Hexagonal nut, self-locking M8, 2x
- 10) S10 wall plug, 4x
- 11) Washer, 4x
- 12) Screw 8 x 60 mm, 4x
- 13) Lintel bracket, 2x
- 14) Hexagonal nut, self-locking M10
- 15) Hexagonal head screw M10 x 100 mm
- 16) Emergency release handle

- 17) Push arm, straight
- 18) Bolt lock 10 mm, 2x
- 19) Bolt 10 x 34.5 mm, 2x
- 20) Combination self-tapping screw, 4x
- 21) Door bracket
- 22) Information sticker for garage interior
- 23) Installation and Operating Manual

#### Mounting for the wall control unit

- 24) S6 wall plug, 4x
- 25) Screw  $\varnothing 4 \times 50$  mm, 4x

When unpacking, make sure that all items are included in the packages.

### 3. Description of function and product

#### 3.8 Dimensions

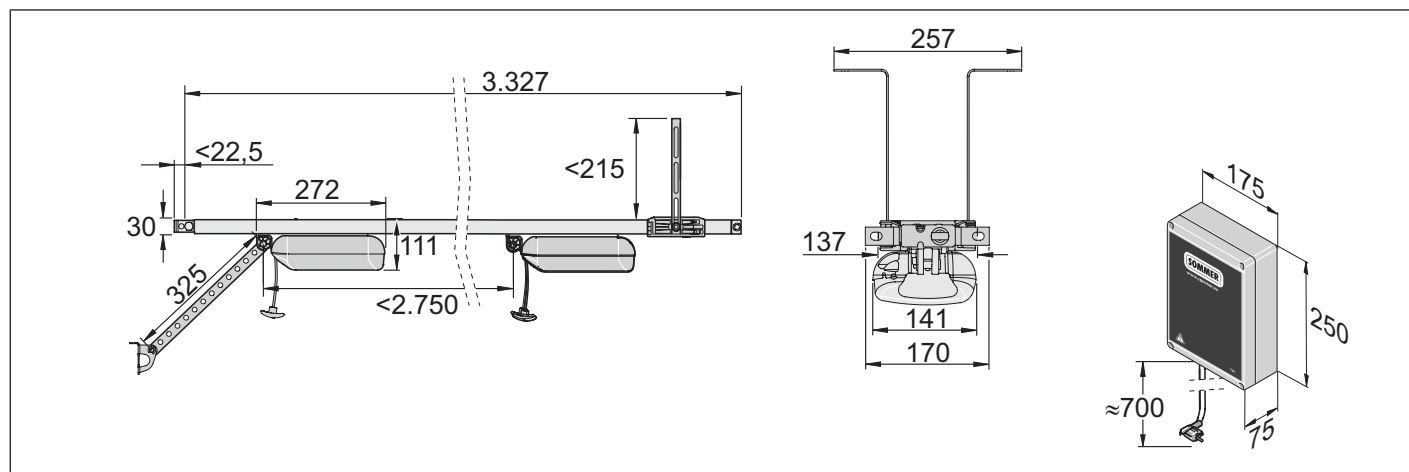

Fig. Dimensions (all dimensions in mm)

#### 3.9 Technical data

	S 9060 tiga	S 9080 tiga	S 9110 tiga	
Rated voltage		AC 220–240 V		
Rated frequency		50–60 Hz		
Rating		3 cycles or 4 minutes		
Memory positions in radio receiver		40		
Duty cycle		S3 = 40 %		
Operating temperature		-25 °C to +65 °C		
Emission value according to operating environment		<59 dB(A) – operator only		
IP protection class		IP65		
IP-code		I		
Max. travel length		2,750 mm		
Max. travel length incl. extension	4,900 mm (2x 1,096 mm)	6,000 mm (3x 1,096 mm)	7,100 mm (4x 1,096 mm)	
Max. speed*	240 mm/s	210 mm/s	180 mm/s	
Max. pull and pushing force	600 N	800 N	1,100 N	
Rated pull force	180 N	240 N	330 N	
Max. current consumption	0.8 A	0.9 A	0.9 A	
Rated current consumption**	0.8 A	0.8 A	0.8 A	
Max. power consumption**	205 W	185 W	175 W	
Rated power consumption	150 W	170 W	165 W	
Power consumption in power-saving mode		<1 W		
Max. door weight*	120 kg	160 kg	200 kg	
Max. door width/door height***	Sectional doors	4,500 mm/2,500 mm	6,000 mm/2,500 mm	8,000 mm/2,500 mm
	One piece doors	4,500 mm/2,750 mm	6,000 mm/2,750 mm	8,000 mm/2,750 mm
	Up-and-over doors	4,500 mm/2,050 mm	6,000 mm/2,050 mm	8,000 mm/2,050 mm
	Side-opening sectional doors/ Side-opening doors	2,500 mm/(4,500 mm)/ 2,500 mm	2,500 mm (5,750 mm)/ 2,750 mm	2,500 mm (6,850 mm)/ 3,000 mm
Max. no. of spaces	30	50	30	

\* Values apply without lighting

\*\* Depending on door and the operating conditions

\*\*\* Reference value, depending on the door construction

### 3. Description of function and product

#### 3.10 Overview of connection options

Only **SOMMER** accessories may be used. Observe the corresponding instructions.

Accessories may only be installed and adjusted by qualified specialists. The use of accessories can vary depending on the type.

Motor carriage	tiga
LED	6
Lock	•
Memo, red housing	•
USART	•
Senso	•
Buzzer	•
Laser	•
Motion	•
for OSE/8k2	•
Wicket door contact	•
Output 12 V, 100 mA	•
DIP switches	4

Wall control unit	tiga
Accumulator	•
Memo, black housing	•
Traffic light, interior, red	•
Traffic light, exterior, red	•
Warning light, 24 V, 3 W	•
2-/4-wire photocell	•
Button, interior request side	•
Button, exterior request side	•
MUFU 1	•
Output DC 24 V	•
DIP switches	4
Relay	•
Safety (EMERGENCY STOP)	•

A SOMlink is also available as an accessory. For more information on accessories, see:



<https://downloads.sommer.eu/>

#### 3.11 Door types and accessories

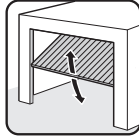
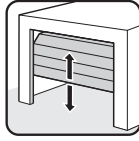
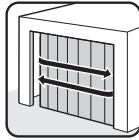
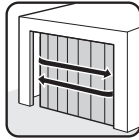
Door type	Accessories	
 One piece door	No accessories required	
	Sectional door with single rail	Sectional door fitting with curved push arm*
	Sectional door with double rail	Sectional door fitting without curved push arm**
	Sectional overhead door	No accessories required
	Side-opening door, side-opening sectional door	Side-opening/side-sectional door fitting**

\* Accessories not included in the scope of delivery

\*\* The standard fitting can also be used depending on the installation type. Custom fittings are not included in the scope of delivery.



## 4. Tools and protective equipment

### 4.1 Required tools and personal protective equipment

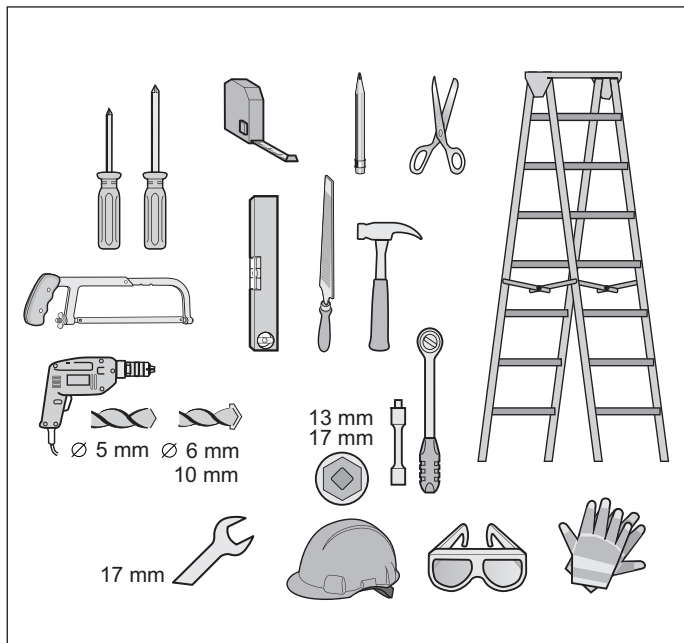

Fig. Recommended tools and personal protective equipment for installation

You will require the tools shown above to assemble and install the operator. Lay out the required tools beforehand to ensure fast and safe installation.

Wear your personal protective equipment. This includes safety glasses, safety gloves and a safety helmet.

## 5. Declaration of incorporation

### Declaration of incorporation

for installation of an incomplete machine in accordance with the Machinery Directive 2006/42/EC, Annex II, Part 1 B

**SOMMER Antriebs- und Funktechnik GmbH**

Hans-Böckler-Straße 27

73230 Kirchheim/Teck

Germany

hereby declares that the control units

**S 9060 tiga, S 9080 tiga, S 9110 tiga,  
S 9060 tiga+, S 9080 tiga+, S 9110 tiga+**

have been developed, designed and manufactured in conformity with the:

- Machinery Directive 2006/42/EC
- Low Voltage Directive 2014/35/EU
- Electromagnetic Compatibility Directive 2014/30/EU
- RoHS Directive 2011/65/EU.

The following standards were applied:

- EN ISO 13849-1, Safety of machines – Safety-related parts of controls  
PL “C” Cat. 2  
– Part 1: General design guidelines
- EN 60335-1, Safety of electrical appliances/operators for doors  
EN 61000-6-3 Electromagnetic compatibility (EMC) – interference
- EN 61000-6-2 Electromagnetic compatibility (EMC) – interference resistance
- EN 60335-2-95 General safety requirements for household and similar electrical appliances  
– Part 2: Particular requirements for operators for vertically moving garage doors for residential use
- EN 60335-2-103 General safety requirements for household and similar electrical appliances  
– Part 2: Special requirements for operators for gates, doors and windows

The following requirements of Annex 1 of the Machinery Directive 2006/42/EC are met: 1.1.2, 1.1.3, 1.1.5, 1.2.1, 1.2.2, 1.2.3, 1.2.4, 1.2.5, 1.2.6, 1.3.1, 1.3.2, 1.3.4, 1.3.7, 1.5.1, 1.5.4, 1.5.6, 1.5.14, 1.6.1, 1.6.2, 1.6.3, 1.7.1, 1.7.3, 1.7.4

The special technical documentation was prepared in accordance with Annex VII Part B and will be submitted to regulators electronically on request.

The operator may only be used:

- in combination with door types in the reference list, which can be found under Certifications:

[www.sommer.eu](http://www.sommer.eu)

The incomplete machine is intended solely for installation in a door system to form a complete machine as defined by the Machinery Directive 2006/42/EC. The door system may only be put into operation after it has been established that the complete system complies with the EC Directives listed above. The undersigned is responsible for compilation of the technical documents.

Kirchheim/Teck,  
20.04.2016



i.v.

Jochen Lude  
Responsible for documents

## 6. Installation

### 6.1 Important notes and information

In particular, please observe and comply with the following warnings, notes and information to ensure safe installation.

#### DANGER



##### **Danger if not observed!**

If warnings are not observed, serious injury or death may result.

- ▶ All warnings must be complied with.

#### WARNING



##### **Danger of falling!**

Unsafe or defective ladders may tip and cause serious or fatal accidents.

- ▶ Use only a non-slip, stable ladder.
- ▶ Ensure that ladders are safely positioned.



##### **Danger for trapped persons!**

Persons may be trapped inside the garage. If trapped persons cannot free themselves, severe injury or death may result.

- ▶ Check the function of the emergency release at monthly intervals, **particularly** from inside in the door CLOSE end position and if necessary, also from outside.
- ▶ If there is no second entrance to the garage, you must have a release lock or a Bowden wire for unlocking from the outside installed. This can be used to free persons who cannot free themselves.



##### **Danger due to falling parts of doors!**

If a door is incorrectly balanced, springs may break suddenly. Falling door parts may cause serious injury or death.

Check:

- ▶ the stability of the door.
- ▶ that the door does not bend, rotate or twist when you open or close it.
- ▶ that the door runs smoothly in the rails.



##### **Danger due to falling ceiling and wall parts!**

The operator cannot be installed correctly if ceiling and walls are unstable or if unsuitable mounting materials are used. Persons or animals may be struck by falling parts of the wall, ceiling or operator. Severe injuries or death may result.

- ▶ You must test the stability of the ceiling and the walls.
- ▶ Use only permissible mounting materials appropriate for the supporting surface.



##### **Danger of entrapment!**

Loose clothing or long hair may be trapped by moving parts of the door. Severe injuries or death may result.

- ▶ Keep clear of the moving door.
- ▶ Always wear tight-fitting clothing.
- ▶ Wear a hairnet if you have long hair.



##### **Danger of crushing and shearing!**

If the door moves and there are persons or animals in the movement area, crushing and shearing injuries may be caused by the mechanism and safety edges of the door.

- ▶ Only use the operator when you have a direct view of the door.
- ▶ All danger zones must be visible during the entire door operation.
- ▶ Always keep the moving door in sight.
- ▶ Keep persons and animals clear of the range of movement of the door.
- ▶ Never put your hand near the door when it is moving or near moving parts. In particular, do not reach into the moving push arm.
- ▶ Do not reach into the ceiling suspension unit when the motor carriage is running along the rail.
- ▶ Do not drive through the door until it has opened completely.
- ▶ Never stand under the opened door.



##### **Danger of tripping and falling!**

Unsafely positioned parts such as packaging, operator parts or tools may cause trips or falls.

- ▶ Keep the installation area free of unnecessary items.
- ▶ Place all parts where no-one is likely to trip or fall over them.
- ▶ The general workplace guidelines must be observed.



##### **Risk of eye injury!**

Chips flying when drilling may cause serious injuries to eyes and hands.

- ▶ Wear safety glasses when drilling.



##### **Risk of injury in the head region**

Impact with suspended objects may cause serious abrasions and cuts.

- ▶ You must wear a safety helmet when installing suspended parts.



## 6. Installation

### CAUTION



#### Risk of injury to hands!

Rough metal parts may cause abrasions and cuts when picked up or touched.



- ▶ Wear safety gloves when deburring or performing similar work.

### NOTE

- If the ceiling and walls are not stable, parts of the ceiling and wall or the operator may fall. Objects may be damaged.  
Ceiling and walls must be stable.
- To prevent damage to the door or operator, use only approved mounting materials such as wall plugs or screws.  
The mounting material must be suitable for the material of the ceiling and walls. This applies particularly for prefabricated garages.

### 6.2 Preparing for installation

Before installation, you must check whether the operator is suitable for the door, see also Chapter “3.9 Technical data”.

#### Removal of actuation parts

### WARNING



#### Danger of entrapment!

Persons or animals may be trapped by straps or cords and pulled into the movement zone of the door. Severe injuries or death may result.

- ▶ Remove straps and cords used for mechanical actuation of the door.

Before installation remove:

- all cords or straps necessary to operate the door by hand.

### Disabling mechanical locks

The mechanical lock on a door with an operator must be removed or disabled if it is not compatible with the operator.

### NOTE

- If locks or other locking systems are installed on a mechanical door, they may block the operator. This may cause faults or damage to the operator.
- Before the installation of the operator, all mechanical locking systems must be disabled.

### Checking the mechanism and weight balance

### WARNING



#### Danger due to falling parts of doors or complete door panels!

Wires, spring sets and other fittings can be damaged and break. The complete door panel can fall. Persons or animals may be struck by falling parts of the door or the complete door panel. Severe injuries or death may result. Before installation, a **qualified specialist** must check and, if necessary, adjust the following:

- ▶ wires, spring sets and other fittings of the door.
- ▶ the weight balance of the door.

### WARNING



#### Danger of entrapment!

If the force setting is too high, persons or animals in the movement area of the door may be trapped and pulled along with the door. Severe injuries or death may result.

- ▶ The force setting is relevant to safety and must be carried out by a trained specialist.
- ▶ You must proceed with extreme caution if you check and if necessary adjust the force setting.

### NOTE

- If the weight compensation of the door is incorrectly adjusted, the operator may be damaged.
  - The door must be stable.
  - It must not bend, rotate or twist when opening and closing.
  - The door must move easily in the rails.

## 6. Installation

1. Check the mechanisms of the door, such as cables, spring sets and other fittings.

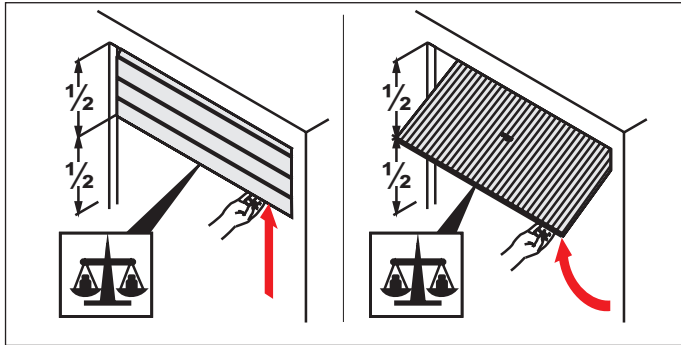

Fig. 2

2. Open the door halfway.
  - ⇒ The door must remain in this position.
  - ⇒ The door must be moved easily by hand and must be balanced.

If the door moves upwards or downwards by itself, the weight balance of the door must be adjusted.

### Emergency release

In a garage without a separate entrance (e.g. wicket door), the operator's emergency release must be operable from outside. The emergency release must also be routed to be accessible from the outside. This can be done with a Bowden wire or a release lock.



### INFORMATION

- The emergency release must be easy to operate in all necessary positions.
- In particular, unlocking must be possible in door CLOSE.

## 6.3 Installing the drive system

### Selection of the installation variant

The scope of delivery offers the option of implementing the following installation variants.

Check your specific situation and select the optimum installation variant for you.

### Installation situation A, B and C

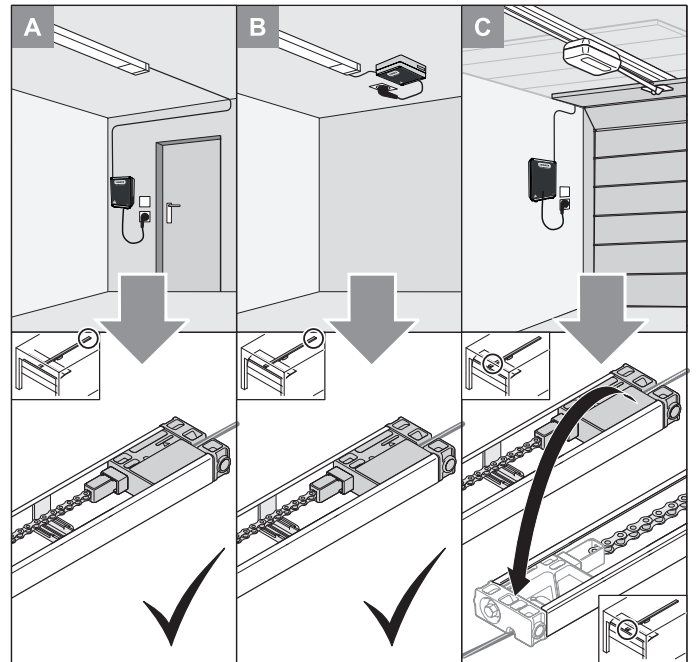

Fig. Installation variants A, B and C

### Variant A

This variant is selected if there is a separate entrance to the garage. The wall control unit is installed near a power outlet. The control cable is led out at the rear end of the rail; see Chapter “6.4 Installing installation variant A or B of the operator system”.

### Variant B

This variant is selected when an existing device is being replaced by a new one and there is already a power outlet or other control lines to buttons or photocells in this area. Here, the wall control unit is mounted on the ceiling in the rear area of the track. The control cable of the plug-in unit is also led out at the rear end of the rail; see Chapter “6.4 Installing installation variant A or B of the operator system”.

### Variant C

This variant is selected when there is a power outlet which can be used for the wall control unit located near the door opening.

Here, the control cable is led out at the front end of the rail; see Chapter “6.5 Installing installation variant C of the operator system”.

## 6. Installation

### 6.4 Installing installation variant A or B of the operator system

The operator may only be installed if the installation requirements and dimensions below are correct.

#### NOTE

- Specify the position for mounting the operator on the door. Manually open and close the door several times. The door must be moved easily.

A manual movement force of 150 N is applicable for private garage doors and 260 N for commercial doors. The value is applicable for the entire life of the door. The door must also be maintained and inspected as specified by the door manufacturer.

#### INFORMATION

- Before installation, check whether the garage is suitable for the operating temperature indicated on the motor carriage.

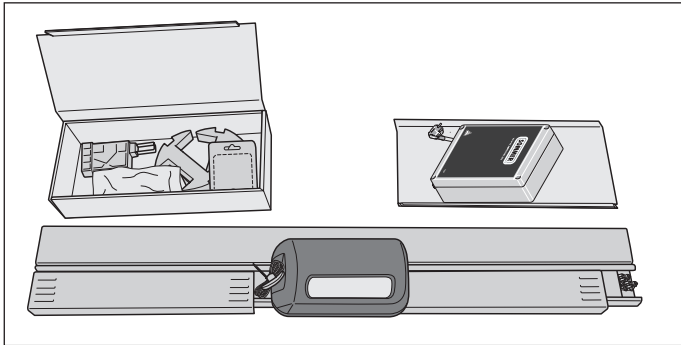

Fig. 1

#### CAUTION! Risk of injury to hands

Rough metal parts may cause abrasions and cuts when picked up or touched.

- You must wear safety gloves when working with rough metal parts.

- Open the packages.

Check the contents against the scope of delivery listed in this Installation and Operating Manual; see Chapter "3.7 Scope of delivery".

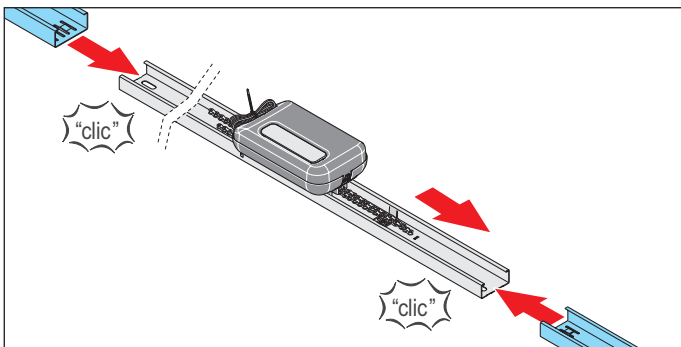

Fig. 2

- Remove the two connecting sleeves beside the motor carriage and attach to the rail on the left and right.

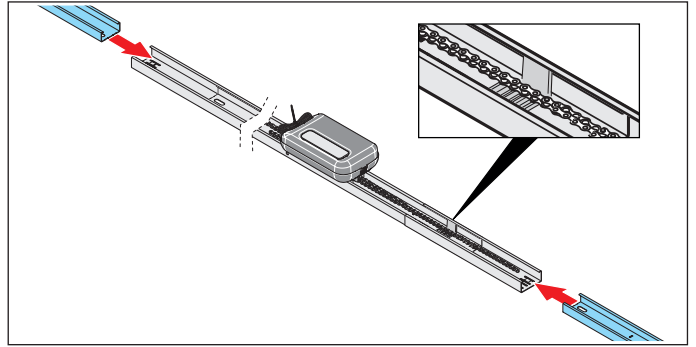

Fig. 3

- Attach a rail to each of the connecting sleeves.

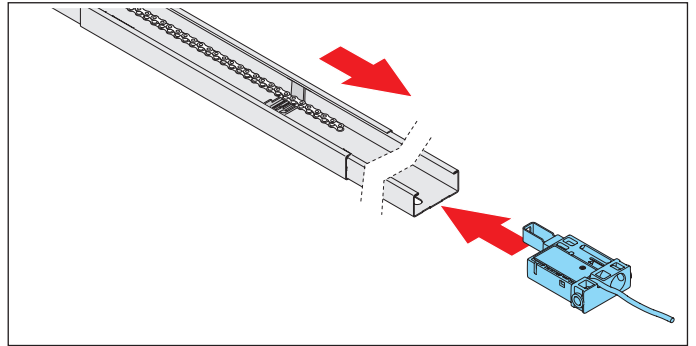

Fig. 4

- Plug in the **plug-in unit with control cable** on the side of the rail **with limit stop**.

Lay the chain over the limit stop.

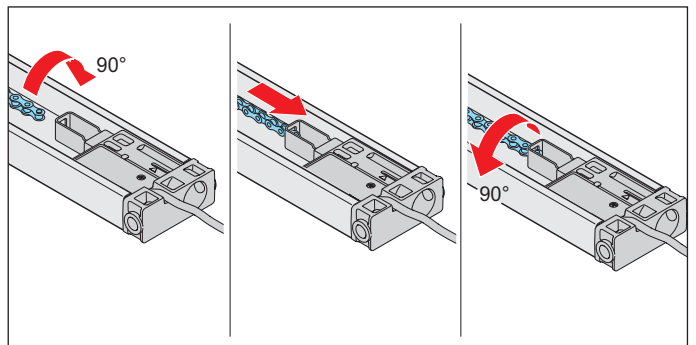

Fig. 5

- Rotate the chain 90° and insert it into the chain holder of the **plug-in unit with control cable**.

Rotate the chain back 90°.

## 6. Installation

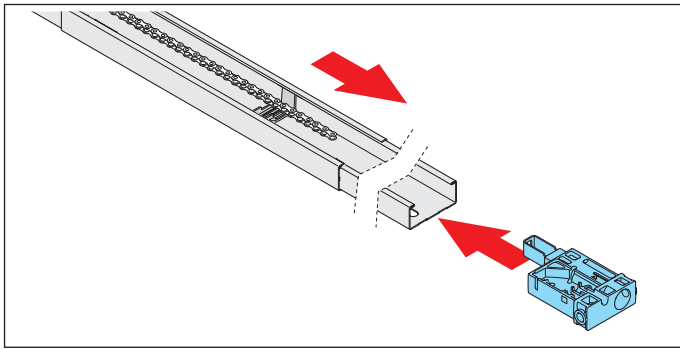

Fig. 6

5. Plug in the **plug-in unit without control cable** on the side of the rail **without** limit stop.

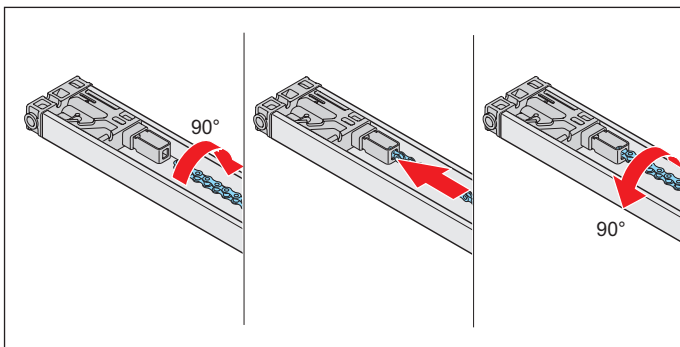

Fig. 7

### NOTE

- The chain must be parallel to the rail to prevent damage to the operator.

6. Rotate the chain 90° and insert it into the chain holder of the **plug-in unit without control cable**.

Rotate the chain back 90°.

⇒ The entire chain is attached.

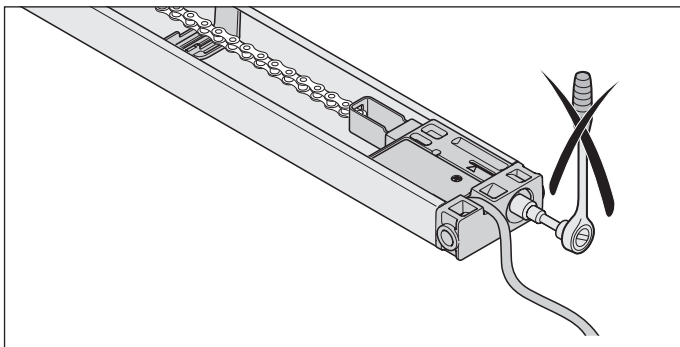

Fig. Plug-in unit with control cable

### NOTE

- The plug-in unit with control cable must not be tensioned.

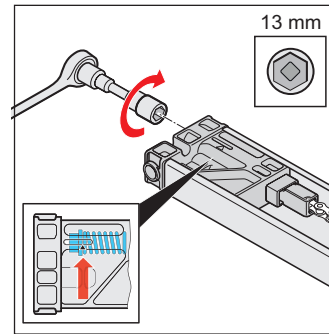

Fig. 8

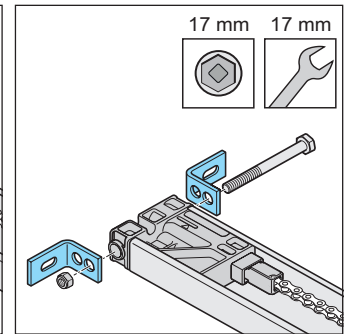

Fig. 9

7. Tension the chain to the mark on the **plug-in unit without control cable**; see arrow in the detailed view.
8. Fasten the two header brackets to the **plug-in unit without control cable** with screw and nut.

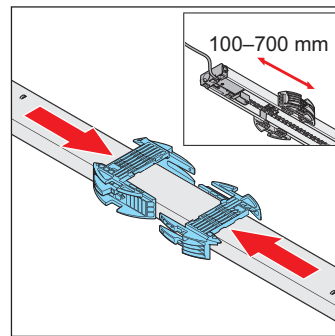

Fig. 10

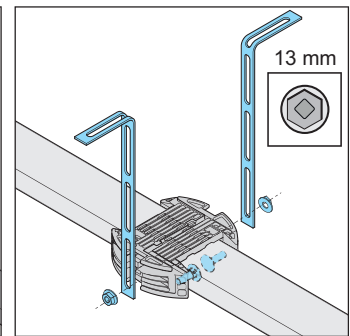

Fig. 11

9. Turn the rail to install the ceiling bracket.

The distance between the rear **plug-in unit with control cable** and the ceiling holder should be approx. 100-700 mm.

Place the ceiling holder on the rail and slide into one another.

### NOTE

- Depending on the door construction, the installation situation and the installation type, it should be checked whether a second ceiling bracket is necessary.

10. Fasten the perforated strips to the ceiling holder on the right and left. Also observe the distances for installation to the ceiling or lintel.

⇒ The rail is prepared for the remainder of the installation.

For further installation, see Chapter “6.6 Installation on the door”.

## 6. Installation

### 6.5 Installing installation variant C of the operator system

The operator may only be installed if the installation requirements and dimensions below are correct.

#### NOTE

- Specify the position for mounting the operator on the door. Manually open and close the door several times. The door must be moved easily. A manual movement force of 150 N is applicable for private garage doors and 260 N for commercial doors. The value is applicable for the entire life of the door. The door must also be maintained and inspected as specified by the door manufacturer.

#### INFORMATION

- Before installation, check whether the garage is suitable for the operating temperature indicated on the motor carriage.

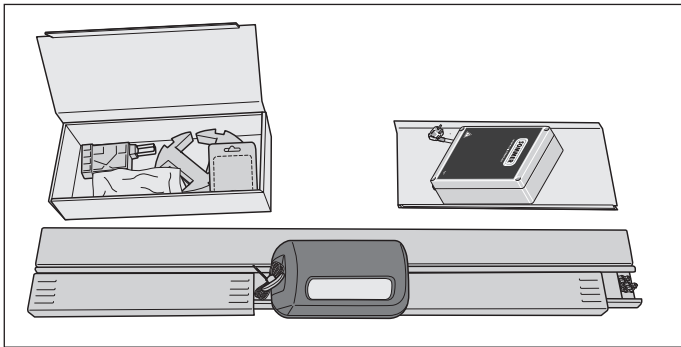

Fig. 1

#### CAUTION! Risk of injury to hands

Rough metal parts may cause abrasions and cuts when picked up or touched.

- You must wear safety gloves when working with rough metal parts.

#### 1. Open the packages.

Check the contents against the scope of delivery listed in this Installation and Operating Manual; see Chapter "3.7 Scope of delivery".

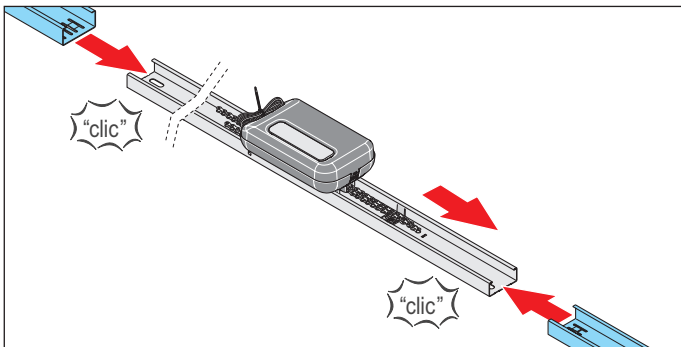

Fig. 2

#### 2. Remove the two connecting sleeves beside the motor carriage and attach to the rail on the left and right.

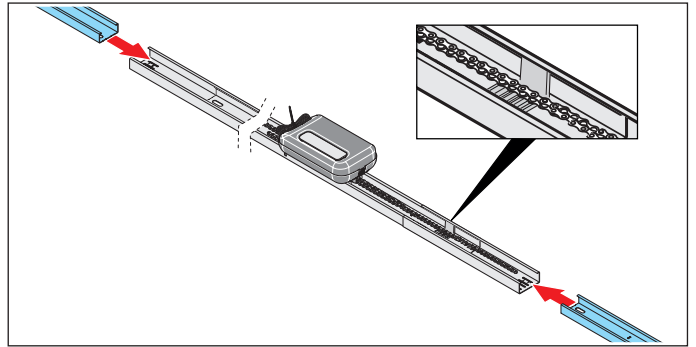

Fig. 3

#### 3. Attach a rail to each of the connecting sleeves.

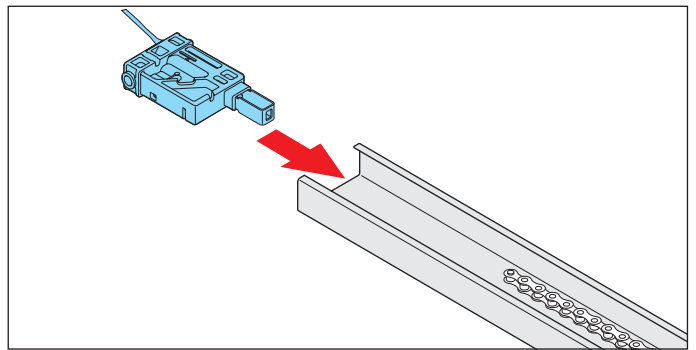

Fig. 4

#### 4. Plug in the **plug-in unit with control cable** on the side of the rail **without** limit stop.

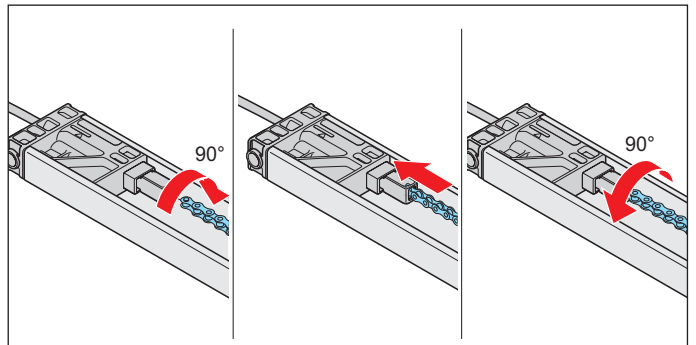

Fig. 5

#### 5. Rotate the chain 90° and insert it into the chain holder of the **plug-in unit with control cable**. Rotate the chain back 90°.

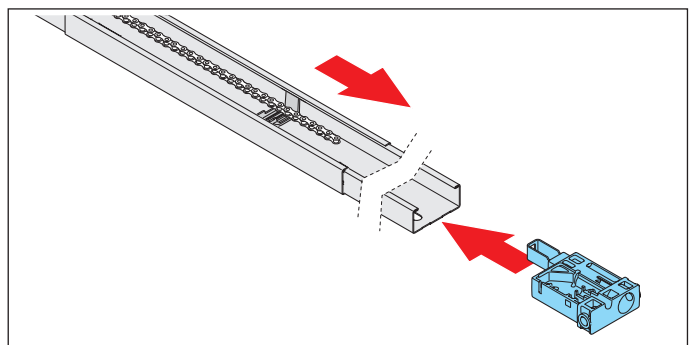

Fig. 6

## 6. Installation

6. Plug in the **plug-in unit without control cable** on the side of the rail **with limit stop**.

Lay the end of the chain over the limit stop.

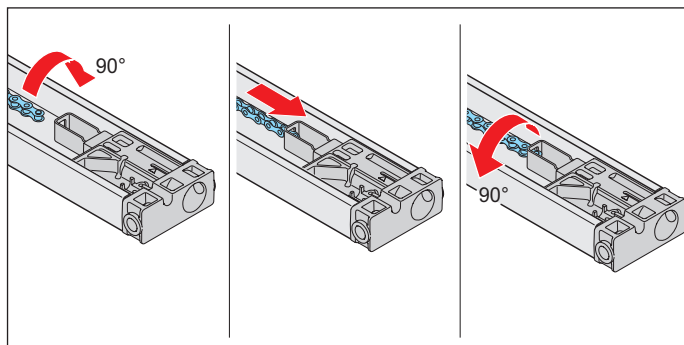

Fig. 7

### NOTE

- The chain must be parallel to the rail to prevent damage to the operator.

7. Rotate the chain 90° and insert it into the chain holder of the **plug-in unit without control cable**.

Rotate the chain back 90°.

⇒ The entire chain is attached.

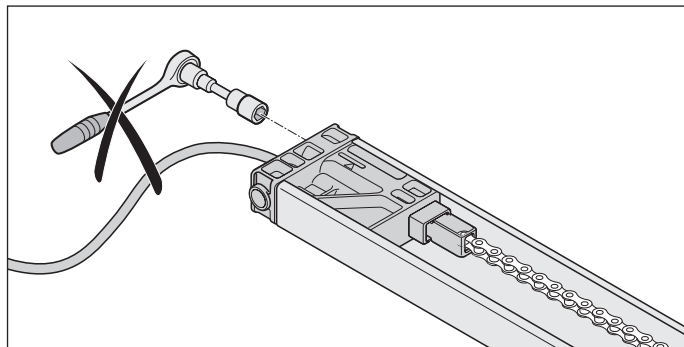

Fig. Plug-in unit with control cable

### NOTE

- The plug-in unit with control cable must not be tensioned.

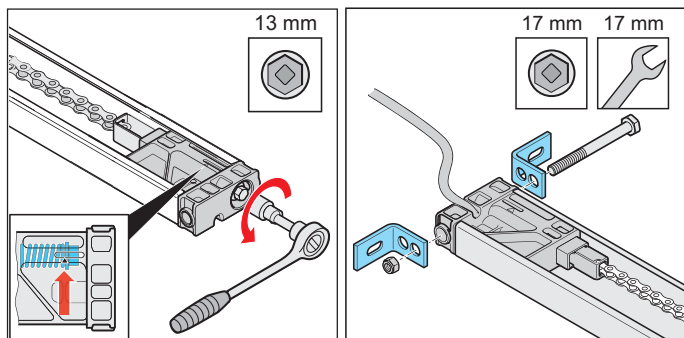

Fig.8

Fig. 9

8. Tension the chain to the mark on the **plug-in unit without control cable**; see **arrow** in the detailed view.

9. Fasten the two header brackets to the **plug-in unit with control cable** with screw and nut.

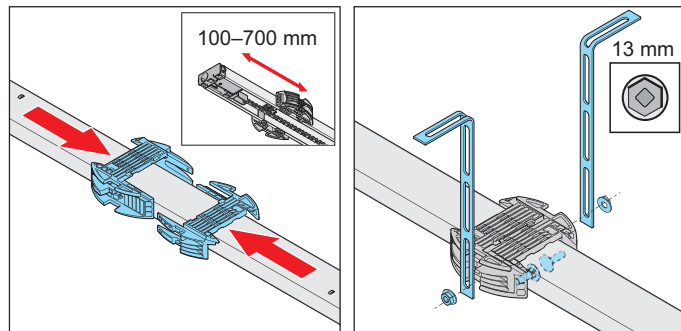

Fig. 10

Fig. 11

10. Turn the rail to install the ceiling bracket.

The distance between the rear **plug-in unit without control cable** and the ceiling holder should be approx. 100–700 mm.

Place the ceiling holder on the rail and slide into one another.

### NOTE

- Depending on the door construction, the installation situation and the installation type, it should be checked whether a second ceiling bracket is necessary.

11. Fasten the perforated strips to the ceiling holder on the right and left. Also observe the distances for installation to the ceiling or lintel.

⇒ The rail is prepared for the remainder of the installation.

For further installation, see Chapter “6.6 Installation on the door”.



## 6. Installation

### 6.6 Installation on the door

Since installation on the door is similar for all variants, installation on the door is only described for variants A and B.

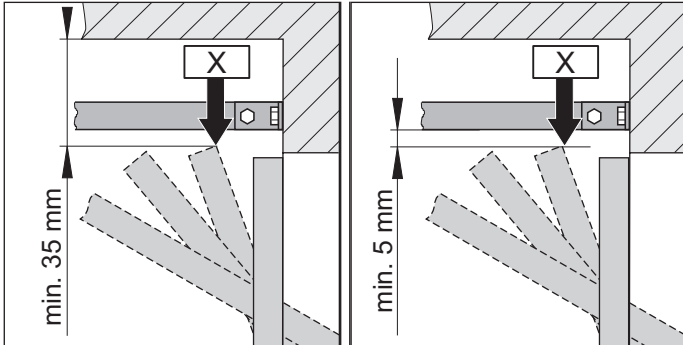

Fig. 1.1 Highest running point for one piece and up-and-over doors

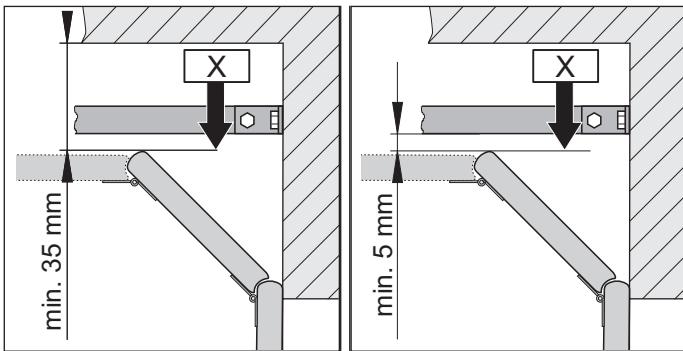

Fig. 1.2 Highest running point for a sectional door

#### **i** INFORMATION

- The distance may be reduced if a door handle is attached to the middle of the door. The door must be able to run freely.

1. Measure the highest running point of the door "X" depending on the door type:

Open the door and measure the closest distance (min. 35 mm) between the top edge of the door and the ceiling. The distance between "X" and the bottom edge of the rail must be at least 5 mm.

If the distance between the ceiling and the bottom edge of the rail is greater than 245 mm, extend the ceiling holders with additional perforated strips.

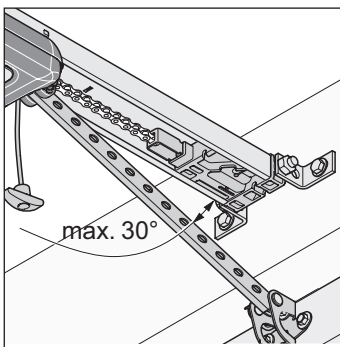

Fig. 2

2. The push arm must be at a max. angle of 30° with the door closed.

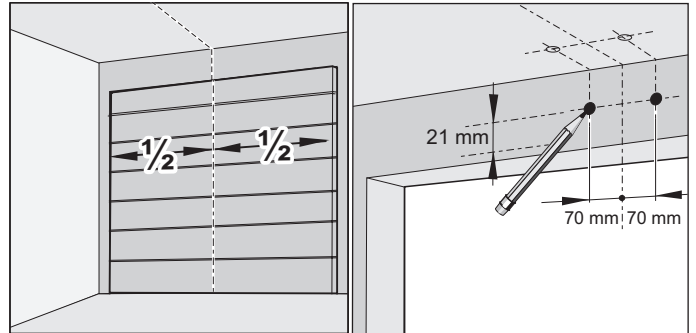

Fig. 3

Fig. 4

3. Close the door.

Select the lintel or ceiling for installation. The space required for ceiling installation is more than 35 mm.

Measure the centre of the door at the front and mark the position on the door and the lintel or ceiling.

4. Mark points 70 mm to the right and left of the centre of the door at the same height on the lintel or ceiling.

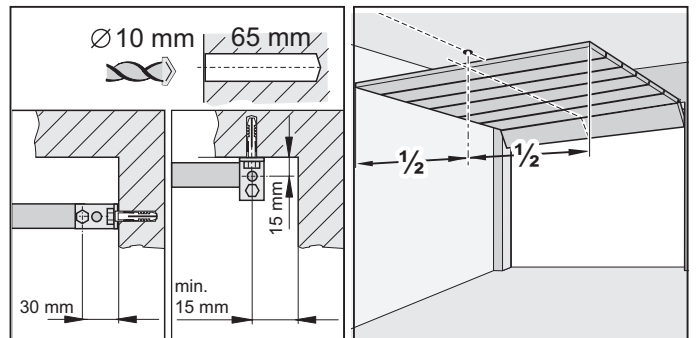

Fig. 5

Fig. 6

#### **NOTE**

- Cover the operator during drilling to prevent dirt from entering the operator unit and damaging it.

#### **i** INFORMATION

- If installing on the ceiling, space the drill holes 15 mm apart if possible. This reduces the tilting angle of the mounting bracket.
- The drilling depth must be considered with respect to the ceiling and wall thickness, particularly with prefabricated garages. It may be necessary to reduce the hole depth.
- Only use permissible mounting materials appropriate for the supporting surface.

5. Drill two holes (Ø 10 x 65 mm deep) in the ceiling or lintel.

## 6. Installation

### 6. Open the door.

Transfer the mark from the centre of the door to the ceiling at the rear.

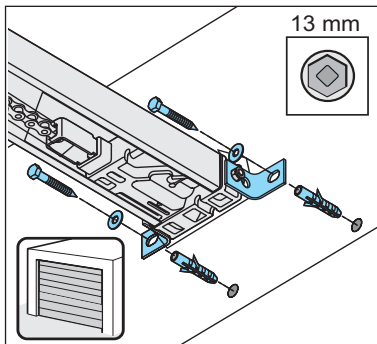

Fig. 7

### 7. Close the door.

Insert the wall plug into the lintel or ceiling. Lift the rail at the front.

Screw the lintel fitting at the front to the lintel or ceiling with two screws and the washers. Tighten the screws.

⇒ The rail is attached to the lintel or ceiling.

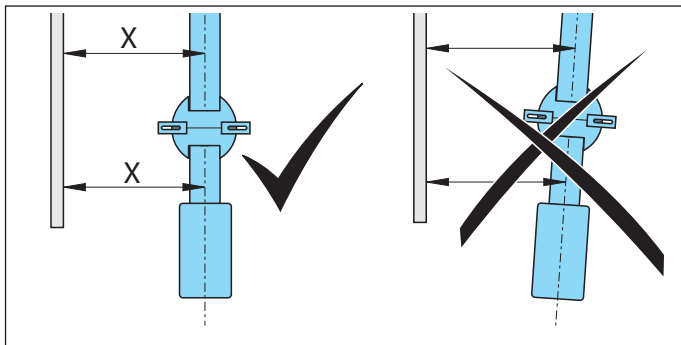

Fig. 8

### NOTE

- The operator must always be installed parallel to the rails of the door to prevent damage to the operator and the rails.

### 8. Align the operator parallel to the tracks of the door.

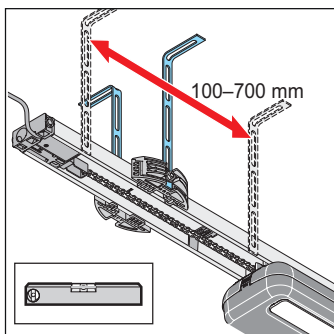

Fig. 9

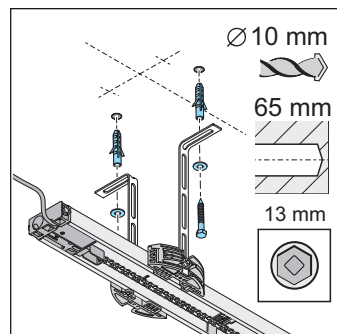

Fig. 10

### 9. Align the rail parallel to centre of the door at the rear.

Align the ceiling bracket.

The distance between the rear plug-in unit and the ceiling holder should be approx. 100–700 mm.

The ceiling bracket should be installed in this area.

Check the alignment of the rail with a spirit level.

### 10. Mark the holes for the ceiling holder on the ceiling.

Drill two holes (Ø 10 x 65 mm deep).

Insert the wall plugs.

Insert two screws with washers and screw to the ceiling with the perforated strips. Tighten the screws.

⇒ The rail is attached to the ceiling.

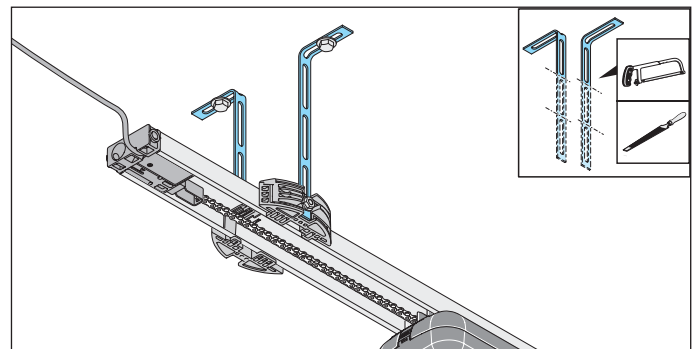

Fig. 11

### ⚠ CAUTION! Risk of injury to hands

Rough metal parts may cause abrasions and cuts when picked up or touched.

- ▶ The projecting perforated strips must be sawn off and deburred to prevent injury.
- ▶ Wear safety gloves when deburring.

### 11. The projecting perforated strips must be shortened.

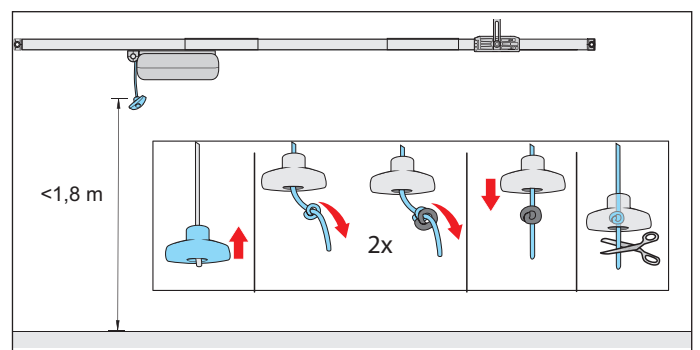

Fig. 12

### ⚠ WARNING! Danger of entrapment

Persons or animals in the movement area of the door may be trapped in a loop of the emergency release cord and the door may be accidentally unlocked. Severe injuries or death may result.

- ▶ The emergency release handle which is included must be used.

## 6. Installation

### NOTE

- The emergency release handle may cause damage, e.g. scratches on the vehicle. The distance between the garage floor and the emergency release cord must be less than 1.8 m.  
The emergency release handle must be at least 50 mm from moving and fixed parts throughout its complete movement range.

12. Attach the emergency release handle:  
Thread the cord through the emergency release handle. Tie a double knot in the cord at an appropriate point. Pull the emergency release handle over the double knot. If necessary, shorten the cord or lengthen it with suitable materials.

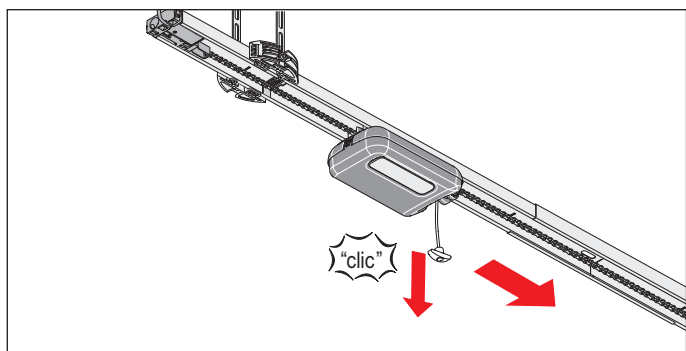

Fig. 13

13. Pull the emergency release cord once to unlock the motor carriage.

Slide the motor carriage forward to the door.

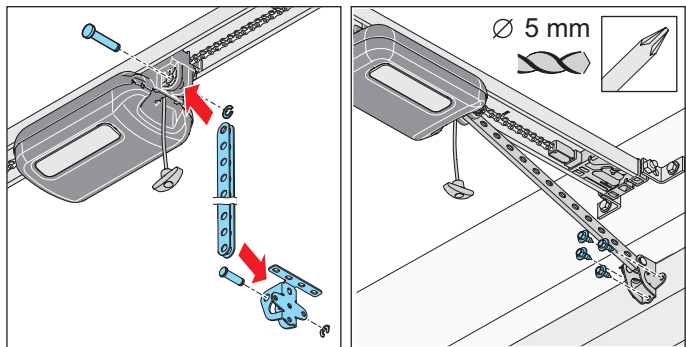

Fig. 15

Fig. 16

### WARNING! Risk of injury in the head region

Impact with suspended objects may cause serious abrasions and cuts.

- You must wear a safety helmet when installing suspended parts.

14. Plug the push arm into the door bracket. Insert the bolt and slide on the security pin.

Plug the push arm into the motor carriage at the front. Insert the bolt and slide on the security pin.

15. Align the door bracket with the centre of the door. Mark the position of the drill holes and drill them ( $\varnothing$  5 mm deep).

Fix the door bracket to the door with the hexagon bolts.

- The push arm is attached to the motor carriage and the door.

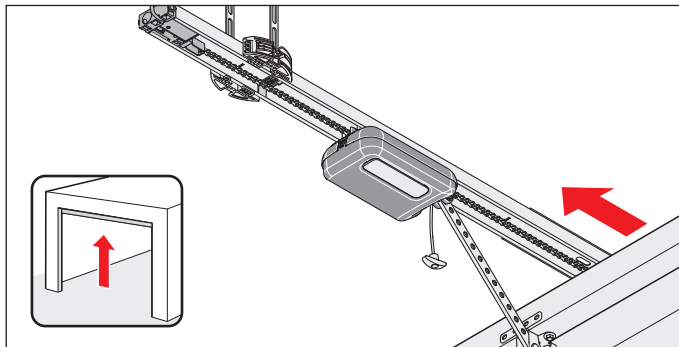

Fig. 16

### NOTE

- The door must not rub against the operator or rails. This could damage the operator or rails. The operator must then be offset.

16. Open the door completely by hand.

If the door rubs against the operator or the rails, the operator must be offset.

- The limit stop moves automatically with the motor carriage.

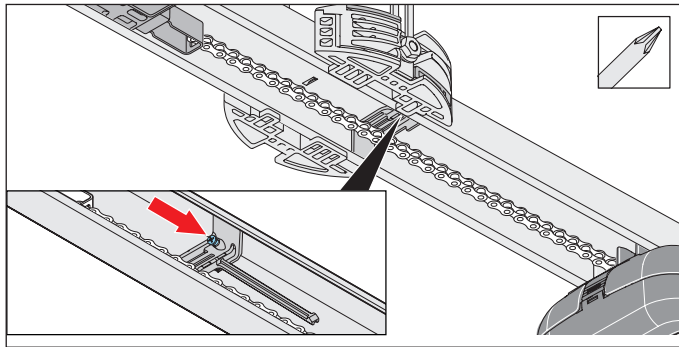

Fig. 17

### NOTE

- Do not push the door to the mechanical stop. Otherwise, the operator will pull the door against the mechanical stop. This will apply tension to the door and it may be damaged.  
A clearance of about 30 mm is required.

### INFORMATION

- The limit stop can be subsequently pushed under the chain and screwed into the rail. Then screw the limit stop tightly to the rail at the respective spot.

## 6. Installation

17. Tighten the screw on the limit stop with a Phillips screwdriver without changing its position.

Check the door OPEN end position:

Open the door fully for this. The motor carriage moves towards the door OPEN position on the limit stop until a click noise is heard.

⇒ The door OPEN end position is set.

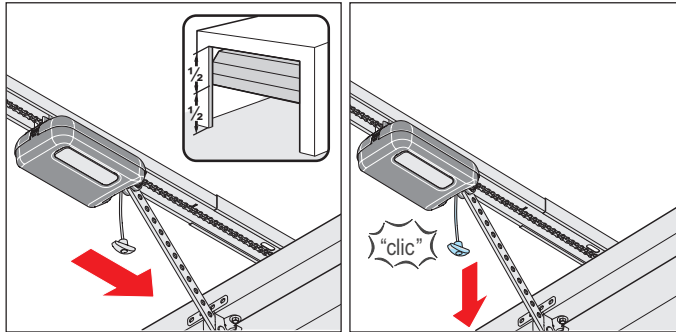

Fig. 18

Fig. 19

18. Move door to centre position.

⇒ The motor carriage moves with it.

19. Pull the emergency release cord.

⇒ **The motor carriage is locked.**

⇒ The door can only be moved by the operator.

⇒ **Installation of the motor carriage and rail is complete.**

### 6.7 Installing the wall control unit

In particular, observe the warnings below.

#### DANGER



#### **Danger due to electric current!**

Contact with live parts may result in electric current flowing through the body. Electric shock, burns or death will result.

- ▶ All work on electrical components must be carried out by a **trained electrician**.
- ▶ Before inserting the mains power plug for the first time, ensure that the voltage of the power source matches the voltage listed on the operator type plate.
- ▶ Do not connect the power supply until installation is complete.
- ▶ Disconnect the mains plug before working on the operator.
- ▶ If a battery pack is connected, disconnect it from the control unit.
- ▶ Check that the operator is not live.
- ▶ Secure the operator against being switched back on.

#### WARNING



#### **Danger of crushing and shearing!**

The door can be actuated via the wall switch. If the door moves and there are persons or animals in the movement area, crushing and shearing injuries may be caused by the mechanism and safety edges of the door.

- ▶ The wall control unit with keypad must be mounted within sight of the door.
- ▶ The wall control unit must not be installed in the direct vicinity of moving parts.
- ▶ The keypad of the wall control unit must be installed at a height of at least 1.5 m.

#### NOTE

- To prevent damage to the operator, do not connect the wall control unit to the power supply until installation is complete.



#### INFORMATION

- The power cord that has been provided may not be shortened or extended.

All devices to be connected externally must have safe isolation of the contacts from the mains voltage supply in accordance with IEC 60364-4-41. Wiring for external devices must be installed in accordance with IEC 60364-4-41.

All electrical wiring must be firmly secured to prevent displacement.

The following must be observed when installing the wall control unit:

- The power cord is approx. 0.7 m long.
- Note that the distance between the wall control unit and the power outlet must not exceed 0.6 m.
- The maximum length of the control cable is 5 m, and it must not be extended.
- The keypad of the wall control unit must be installed at a height of at least 1.5 m.

The direct connection of the wall control unit to an all-pole mains circuit breaker, e.g. a main switch, or to a power outlet, must be fuse-protected; see Chapter “8.1 Connecting to the mains voltage”.

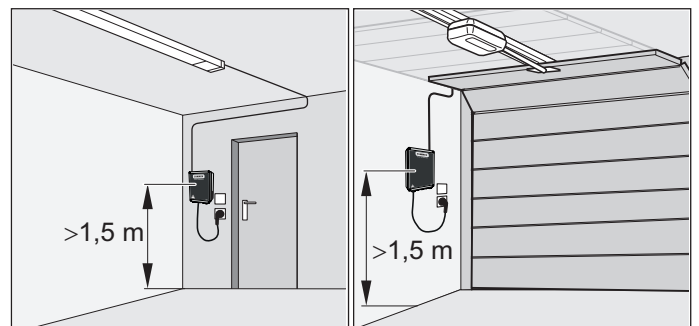

Fig. 1

## 6. Installation

### INFORMATION

• The drilling depth must be considered with respect to the ceiling and wall thickness, particularly with prefabricated garages. It may be necessary to reduce the hole depth.

Only use permissible mounting materials appropriate for the supporting surface.

1. Choose a suitable location for the wall control unit close to an existing power outlet.

The maximum length of the control cable is 5 m, and it must not be extended.

Note that the distance between the wall control unit and the power outlet must not exceed 0.6 m.

The wall control unit must be installed at a height of at least 1.5 m.

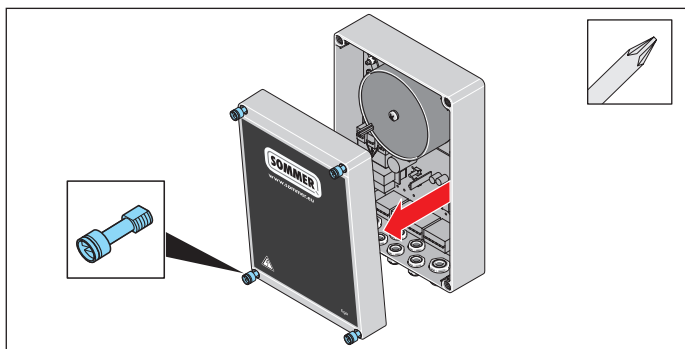

Fig. 2

2. Loosen the four screws of the control unit housing and remove the cover.

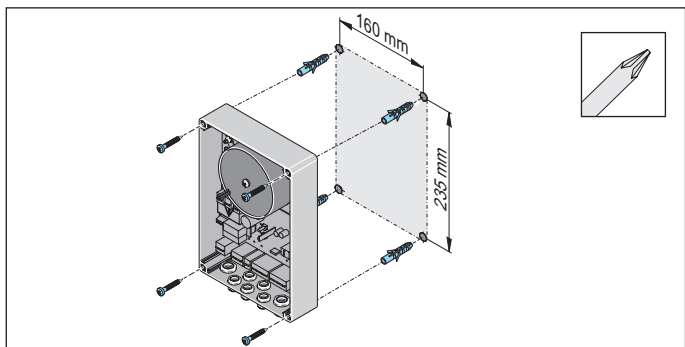

Fig. 3: Installation example

### WARNING! Risk of eye injury!

Chips flying when drilling may cause serious injuries to eyes and hands.

► Wear safety glasses when drilling.

3. Transfer the mounting points to the substructure.

Drill four holes,  $\varnothing 6 \times 50$  mm deep.

Insert the four wall plugs.

Fix the wall control unit in position with four screws, align the unit and firmly tighten the screws.

4. Route the control cable of the plug-in unit up to the wall control unit and secure to prevent displacement.

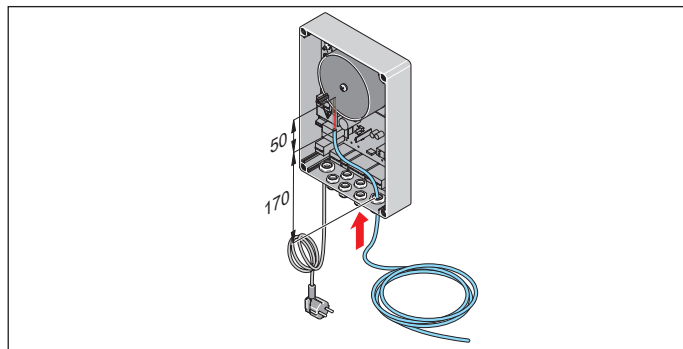

Fig. 5

5. Feed the control cable into the wall control unit through the cable inlet.

Shorten the control cable to no more than 220 mm in length. Uncover the last 50 mm and strip the wires.

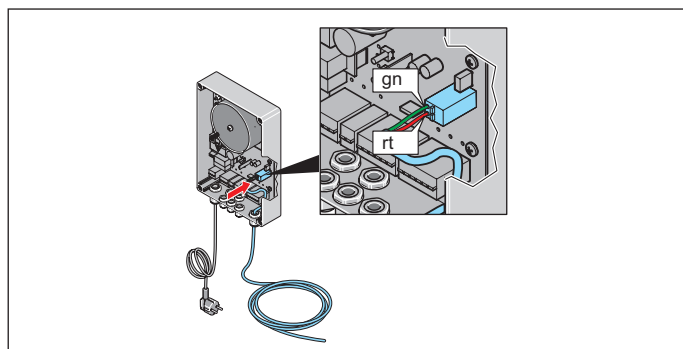

Fig. 6

6. Route the control cable up to the **gn/rd** terminal. Connect the green wire of the control cable to the **gn** terminal.

Connect the red wire of the control cable to the **rd** terminal.

7. Close the housing in reverse order.

⇒ **Installation of the operator is complete.**

Other connection options such as buttons or warning light are described in Chapter “10. Connections and special functions of the motor carriage”.

## 7. Removing and fastening covers

### 7.1 Cover of the motor carriage

In particular, observe the warnings below.

#### WARNING



##### **Danger due to optical radiation!**

Looking into an LED at short range for an extended period may cause optical glare. This may temporarily reduce vision. This may cause serious or fatal accidents.

- ▶ Never look directly into an LED.

#### WARNING



##### **Danger due to hot surfaces!**

After frequent operation, parts of the motor carriage or the control unit may become hot. If the cover is removed and hot parts are touched, they may cause burns.

- ▶ Allow the operator to cool down before removing the cover.

### Removing the cover

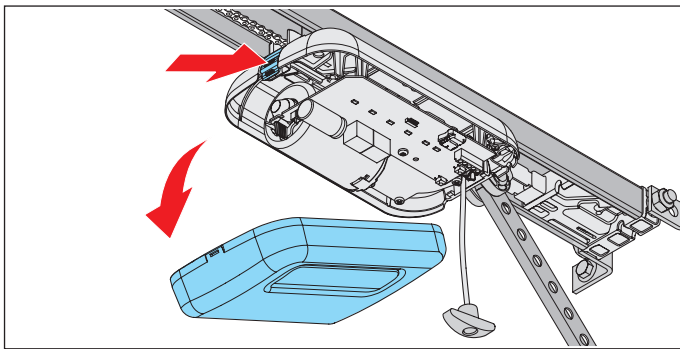

Fig. 1

1. Press on the cover lock at the back of the motor carriage and remove the cover.

### Installing the cover

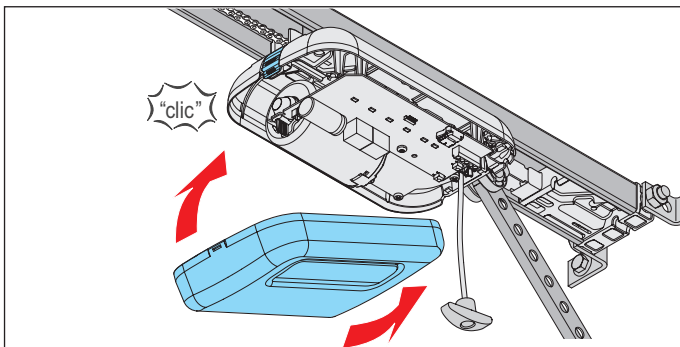

Fig. 1

1. Insert the cover from the front and lock it to the motor carriage at the back.

### 7.2 Cover of the wall control unit

#### Removing the cover

In particular, observe the warnings below.

#### DANGER



##### **Danger due to electric current!**

Contact with live parts may result in electric current flowing through the body. Electric shock, burns or death will result.

- ▶ All work on electrical components must be carried out by a **trained electrician**.
- ▶ Disconnect the mains plug before working on the operator.
- ▶ If a battery pack is connected, disconnect it from the control unit.
- ▶ Check that the operator is not live.
- ▶ Secure the operator against being switched back on.

#### WARNING



##### **Danger due to hot surfaces!**

After frequent operation, parts of the motor carriage or the control unit may become hot. If the cover is removed and hot parts are touched, they may cause burns.

- ▶ Allow the operator to cool down before removing the cover.

1. Disconnect the operator from the mains voltage. Check that the operator is disconnected from the power supply.

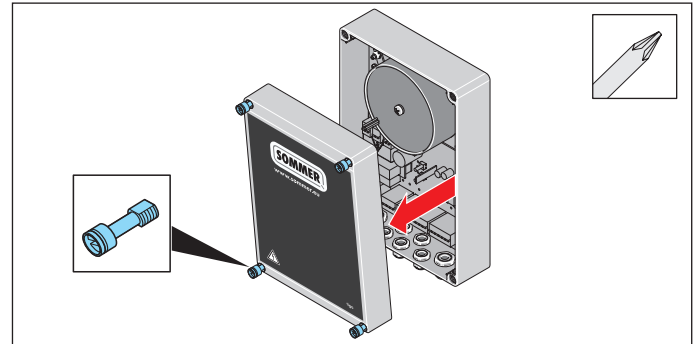

Fig. 2

2. Loosen the four screws of the control unit housing and fold the cover to the side.
3. If a battery pack is used, it must also be disconnected; see Chapter “11.11 Installing and removing the battery pack”.

#### Installing the cover

4. After working on the wall control unit, replace the cover in reverse order.
5. Re-connect the operator to the mains voltage. Check the voltage supply.  
⇒ The operator is supplied with voltage.

## 8. Electrical connection and special functions

### 8.1 Connecting to the mains voltage

The direct connection of the wall control unit to an all-pole mains circuit breaker, e.g. a main switch, or to a power outlet, must be fuse-protected. Local and national installation regulations (e.g. VDE) must be observed. Connection of the operator to the mains voltage must be carried out by **trained electricians** only.

In particular, observe the warnings below.

#### DANGER



#### Danger due to electric current!

Contact with live parts may result in electric current flowing through the body. Electric shock, burns or death will result.

- ▶ All work on electrical components must be carried out by a **trained electrician**.
- ▶ Before inserting the mains power plug for the first time, ensure that the voltage of the power source matches the voltage listed on the operator type plate.
- ▶ Do not connect the power supply until installation is complete.
- ▶ Disconnect the mains plug before working on the operator.
- ▶ If a battery pack is connected, disconnect it from the control unit.
- ▶ Check that the operator is not live.
- ▶ Secure the operator against being switched back on.

#### NOTE

- To prevent damage to the operator, do not connect the wall control unit to the mains voltage until installation is complete.



#### INFORMATION

- All devices to be connected externally must have safe isolation of the contacts from the mains voltage supply in accordance with IEC 60364-4-41.

Wiring for external devices must be installed in accordance with IEC 60364-4-41.

All electrical wiring, including the control cable, must be firmly secured to prevent displacement.

Connection to the mains voltage must not be established until installation has been completed. The connection to the battery pack is established last.

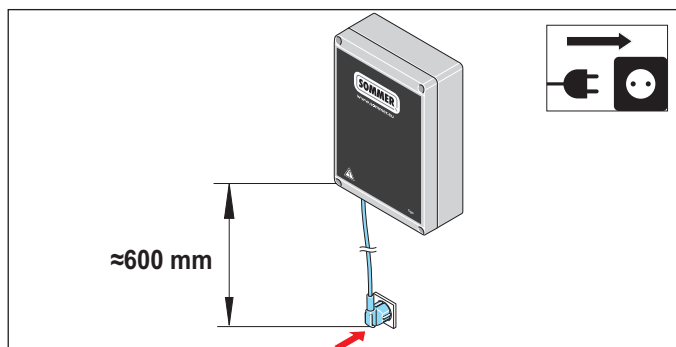

Fig. Installation example – distance between wall control unit and power outlet

In order to connect to a power outlet or to an all-pole mains circuit breaker, e.g. a main switch, the wall control unit must be installed as follows:

- the network cable is about 0.7 m long and must not be shortened or extended.
- the distance between the wall control unit and the power outlet must not exceed 0.6 m.
- easily visible and accessible.

## 9. Initial operation

### 9.1 Important notes and information

In particular, observe the warnings below.

#### WARNING



##### **Danger of entrapment!**

If the force setting is too high, persons or animals in the movement area of the door may be trapped and pulled along with the door. Severe injuries or death may result.

- ▶ The force setting is relevant to safety and must be carried out by a **qualified specialist**.
- ▶ You must proceed with extreme caution if you check and if necessary adjust the force setting.
- ▶ Please note that the operator may only be operated if a non-hazardous force value has been set.
- ▶ Select the force setting low enough to eliminate any danger of injury by the closing force.



##### **Danger of crushing and shearing!**

If the door moves and there are persons or animals in the movement area, crushing and shearing injuries may be caused by the mechanism and safety edges of the door.

- ▶ Only use the operator when you have a direct view of the door.
- ▶ All danger zones must be visible during the entire door operation.
- ▶ Always keep the moving door in sight.
- ▶ Keep persons and animals clear of the range of movement of the door.
- ▶ Never put your hand near the door when it is moving or near moving parts. In particular, do not reach into the moving push arm.
- ▶ Do not reach into the ceiling suspension unit when the motor carriage is running along the rail.
- ▶ Do not drive through the door until it has opened completely.
- ▶ Never stand under the opened door.



##### **Danger due to optical radiation!**

Looking into an LED at short range for an extended period may cause optical glare. This may temporarily reduce vision. This may cause serious or fatal accidents.

- ▶ Never look directly into an LED.

#### NOTE

- In the case of a door without a lintel or without lintel panel, programming of the door CLOSE end position should be carried out as described in Chapter “**9.3 Carrying out manual initial operation**”. Otherwise, the operator may be damaged.
- Do not use a metal object to set the DIP switches, because this may damage the DIP switches or the circuit board.  
Use a suitable tool to set the DIP switches, such as a flat, thin plastic object.
- Objects in the movement area of the door may be jammed and damaged.  
Objects must not be in the range of movement of the door.



#### INFORMATION

- The control unit detects a short-circuit between chain and rail and then switches the operator off.
- If a photocell is used, it must not be actuated when starting the programming.  
If a photocell is used as a frame photocell, move the door to the centre position.

### 9.2 Carrying out automatic initial operation

**Before initial operation**, read this chapter with special care to ensure that you can make the adjustments to the operator safely and optimally.

#### WARNING



##### **Danger of entrapment!**

If the force setting is too high, persons or animals in the movement area of the door may be trapped and pulled along with the door. Severe injuries or death may result.

- ▶ The force setting is relevant to safety and must be carried out by a **qualified specialist**.
- ▶ You must proceed with extreme caution if you check and if necessary adjust the force setting.
- ▶ Please note that the operator may only be operated if a non-hazardous force value has been set.
- ▶ Select the force setting low enough to eliminate any danger of injury by the closing force.



#### INFORMATION

- During initial operation:
  - Stay in the garage, particularly when programming.
  - Obstacle recognition is not yet coordinated to the door and is in the programming phase.
- If a photocell/light curtain is connected for door CLOSE and detected by the control unit, the closing function is automatically activated. Only if the DIP switch on the motor carriage is set to **ON**; see also Chapter “**10. Connections and special functions of the motor carriage**” or Chapter “**18. Connection diagrams and functions of the DIP switches for tiga**”.
- The limit stop can also be retrofitted.
- Programming can be carried out via a handheld transmitter or an external button.

For compliance with EN 13241, before initial operation, the door type must be selected and set on the motor carriage with DIP switches 3 or 4. The motor carriage has an automatic force setting. The motor carriage memorises the required force during the door OPEN and CLOSE movements and stores it when the end position has been reached.



## 9. Initial operation

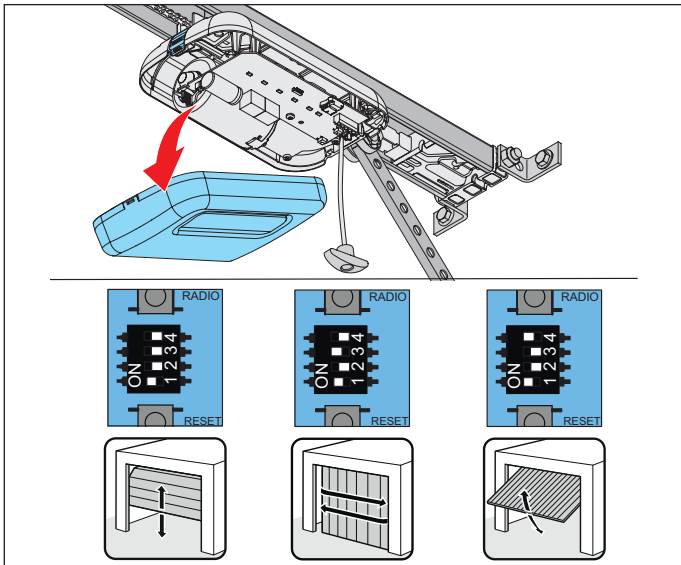

Fig. 1

1. Open the cover of the motor carriage. Set the DIP switches, depending on the door.

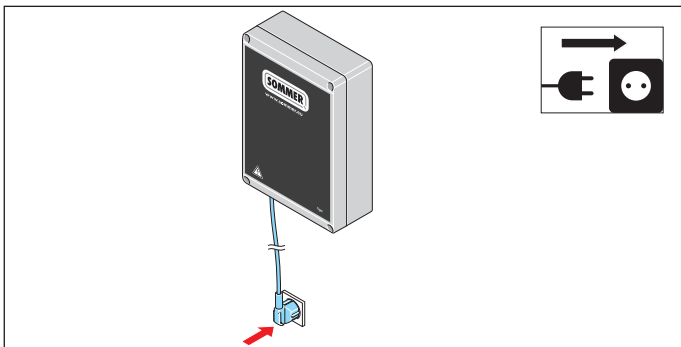

Fig. 2

2. Compare the existing mains voltage with the type plate.

Connect the operator with the mains voltage.

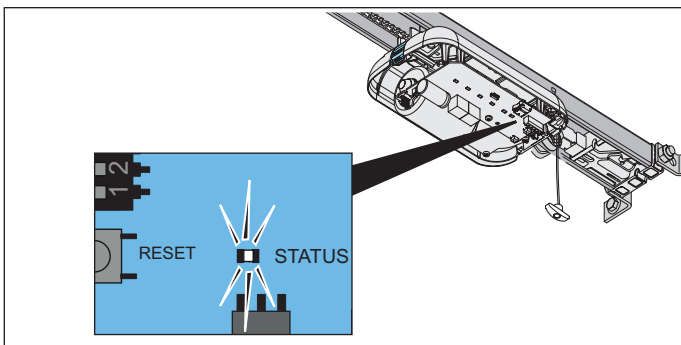

Fig. 2.1

⇒ The status LED of the motor carriage blinks green.

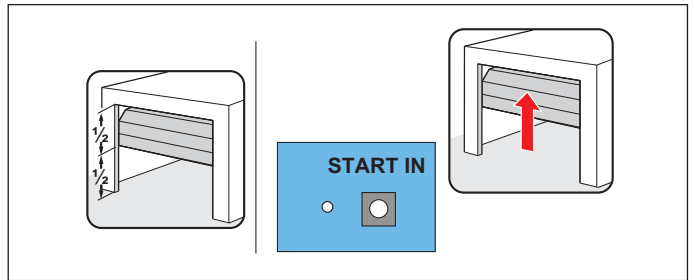

Fig. 3

3. After the operator has been connected to the mains voltage, its first movement after a pulse is always door OPEN.

Press the START IN button on the control unit.

⇒ The motor carriage moves slowly to the door OPEN end position and **automatically** switches off at the limit stop.

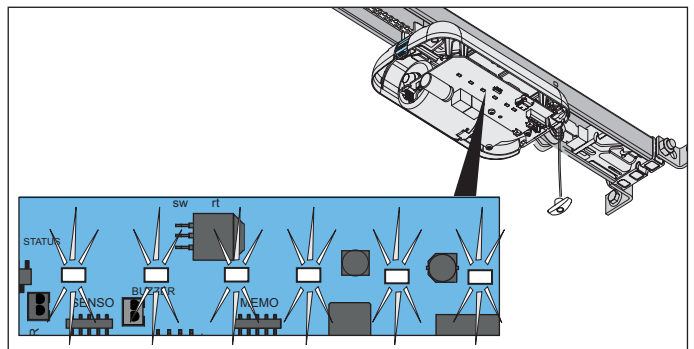

Fig. 3.1

⇒ The operator lighting LEDs blink.

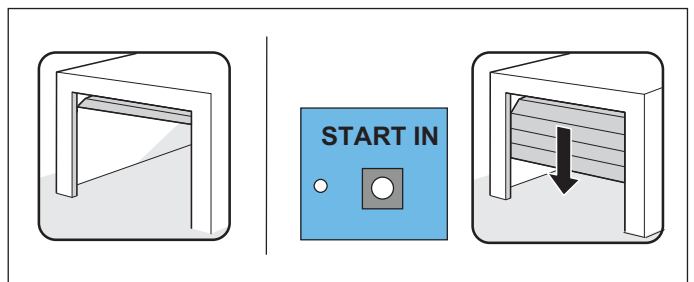

Fig. 4

4. Press the START IN button on the control unit **briefly** (<1 second) to save the end position.

⇒ The motor carriage moves slowly in the door CLOSE direction.

⇒ The operator lighting LEDs blink.

⇒ The motor carriage switches off **automatically** when it reaches the factory-set closing force at the door CLOSE end position.

⇒ The operator lighting LEDs blink in a different sequence.

## 9. Initial operation

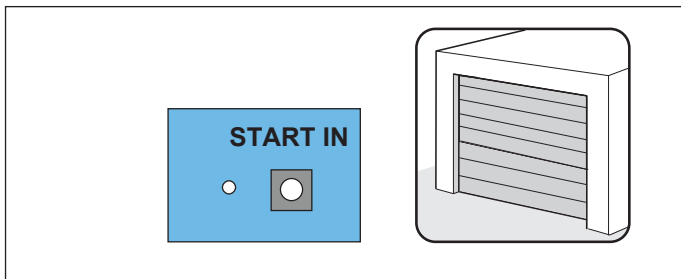

Fig. 5

5. Press the START IN button on the tiga control unit **briefly** (<1 second) to save the end position.

⇒ The operator lighting LEDs blink briefly in a fast sequence.

### The operator automatically starts its programming process

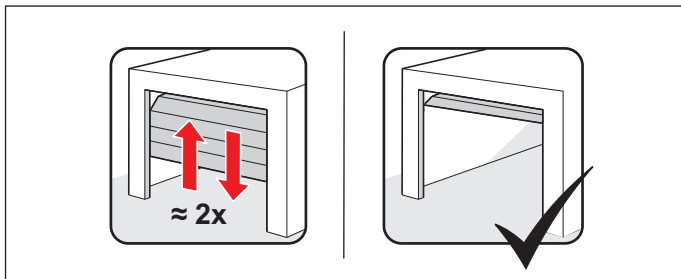

Fig. 5.1

- ⇒ The motor carriage moves **automatically** to the door OPEN end position again and programs the required operating force.
  - ⇒ The motor carriage **automatically** moves to the door CLOSE end position.  
If necessary, the motor carriage moves over the path several times for programming with a greater door weight.
  - ⇒ The motor carriage **automatically** moves briefly in the door OPEN direction to program the soft run.
  - ⇒ The door **automatically** returns to the door CLOSE end position.
  - ⇒ The motor carriage **automatically** moves to the door OPEN end position.
  - ⇒ The LEDs of the operator lighting remain **steady**.
6. The function of the emergency release must be checked in the door CLOSE end position. Unlocking must be possible.
    - ⇒ If a photocell/light curtain is connected, PHOTO 1 for door CLOSE, the door automatically closes after the hold open time and clearing time run out.
    - ⇒ **Operator is programmed and ready for use.**

### INFORMATION

- The motor carriage stops if the door is difficult to move. The door mechanism must be checked; see Chapter “9.4 Detecting obstacles during the force programming run”.
- It may be necessary to adjust the end positions; see Chapter “9.5 Mechanical adjustment of the end positions”
- The force setting must be checked after installation of the operator; see also Chapter “12.1 Testing obstacle detection”.

### 9.3 Carrying out manual initial operation

In the case of doors without lintel or without panel, programming of the door CLOSE end position should be carried out manually. To do this, carry out steps 1.–3. in Chapter “9.2 Carrying out automatic initial operation” and then the steps below:

1. **Briefly** press the START IN button on the control unit.
  - ⇒ The door begins to move towards the door CLOSE end position.
2. Before the door reaches the door CLOSE end position, press the START IN button again **briefly**.
  - ⇒ The door stops.
3. To approach the desired end position for door CLOSE, **press and hold** the START IN button until the motor carriage **moves briefly**.  
Release the START IN button.
4. The process can be repeated until the desired end position is reached.
5. Press the START IN button **briefly** (<1 second) to save the door CLOSE end position.
6. The door then starts the programming process; see Chapter “9.2 Carrying out automatic initial operation”, section “The operator automatically starts its programming process”.

### 9.4 Detecting obstacles during the force programming run

If the door detects an obstacle during its first door CLOSE movement and the force programming runs cannot be completed, the door stops.

#### NOTE

- Check the movement range, mechanism, spring tension and the weight balance to prevent damage to the door system.

## 9. Initial operation

1. **Press and hold** the START IN button on the control unit.
  - ⇒ The motor carriage **moves briefly** and then moves to the **desired end position** for door CLOSE.
2. Release the START IN button.
3. **Fine adjustment:**

Press and hold the START IN button on the control unit until the motor carriage **moves briefly**. Release the START IN button.
- 3.1 The process can be repeated until the desired end position is reached.

Press the START IN button on the control unit **briefly** (1 second) to save the door CLOSE end position.

- ⇒ The motor carriage starts the **automatic** force programming runs for the door OPEN end position.
- ⇒ The motor carriage starts the **automatic** force programming runs for the door CLOSE end position.
- ⇒ If an obstacle is detected again, the motor carriage stops and reverses a short distance. The motor carriage starts the **automatic** force programming run to the door OPEN end position.
- ⇒ The motor carriage starts the **automatic** force programming run to the door CLOSE end position.

If an obstacle is detected again, the motor carriage stops and reverses a short distance.

1. **Press and hold** the START IN button on the control unit.
  - ⇒ The motor carriage starts without jerking, because the end position of the door is already saved.
  - ⇒ The motor carriage moves to the end position.
2. Release the START IN button on the control unit.
3. **Briefly** press the START IN button on the control unit.
  - ⇒ **Automatic force programming runs start again.**
  - ⇒ On completion of the force programming runs, the motor carriage **automatically** moves to the door OPEN end position.
  - ⇒ The LEDs of the operator lighting remain **steady**.
4. The function of the emergency release must be checked in the door CLOSE end position. Unlocking must be possible.
  - ⇒ **Operator is programmed and ready for use.**

### 9.5 Mechanical adjustment of the end positions

#### Increasing the closing pressure of the end position for door CLOSE

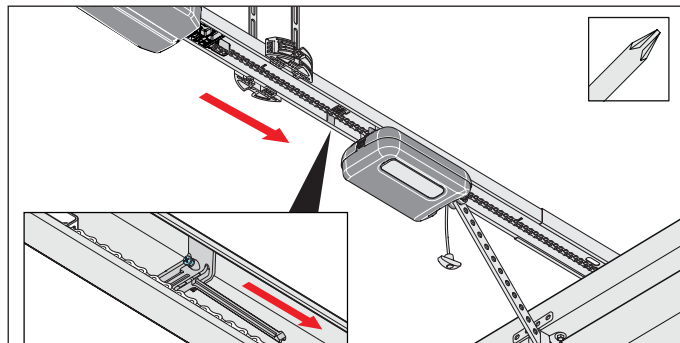

Fig. 1

1. Loosen the screw on the limit stop and move the limit stop a few millimetres in the door CLOSE direction. Re-tighten the screw.
2. The function of the emergency release must be checked in the door CLOSE end position. Unlocking must be possible.

#### Reducing the closing pressure of the end position for door CLOSE

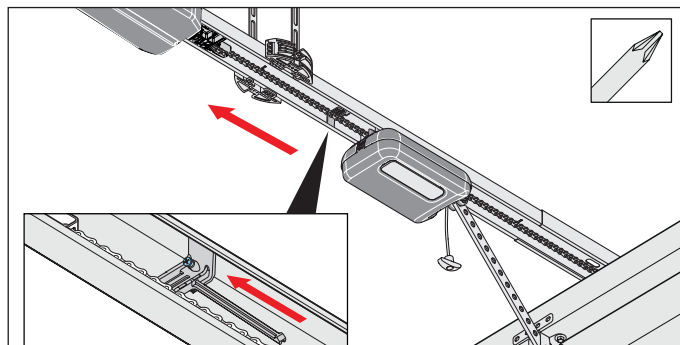

Fig. 1

1. Loosen the screw on the limit stop and move the limit stop a few millimetres in the door OPEN direction. Re-tighten the screw.

#### NOTE

- Do not push the door to the mechanical stop. Otherwise, the operator will pull the door against the mechanical stop. This will apply tension to the door and it may be damaged.  
A clearance of about 30 mm is required.

## 9. Initial operation

### 9.6 Attaching information sign and warning signs

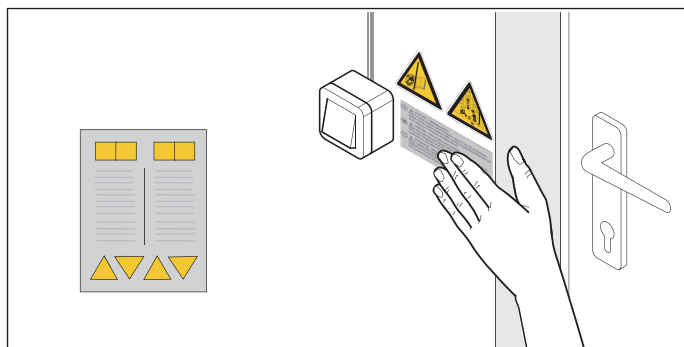

Fig. 1.1 Attach sticker near the stationary control or control unit



Fig. 1.2 Attach sticker to door panel

1. Attach the warning signs and information sign at a suitable and grease-free point:
  - far from moving parts
  - near the stationary control or control unit
  - at eye level in a highly visible section of the door leaf
2. Carry out obstacle detection, see Chapter “12.1 Testing obstacle detection”.
  - ⇒ **Initial operation is complete.**

## 10. Connections and special functions of the motor carriage

### 10.1 Motor carriage circuit board

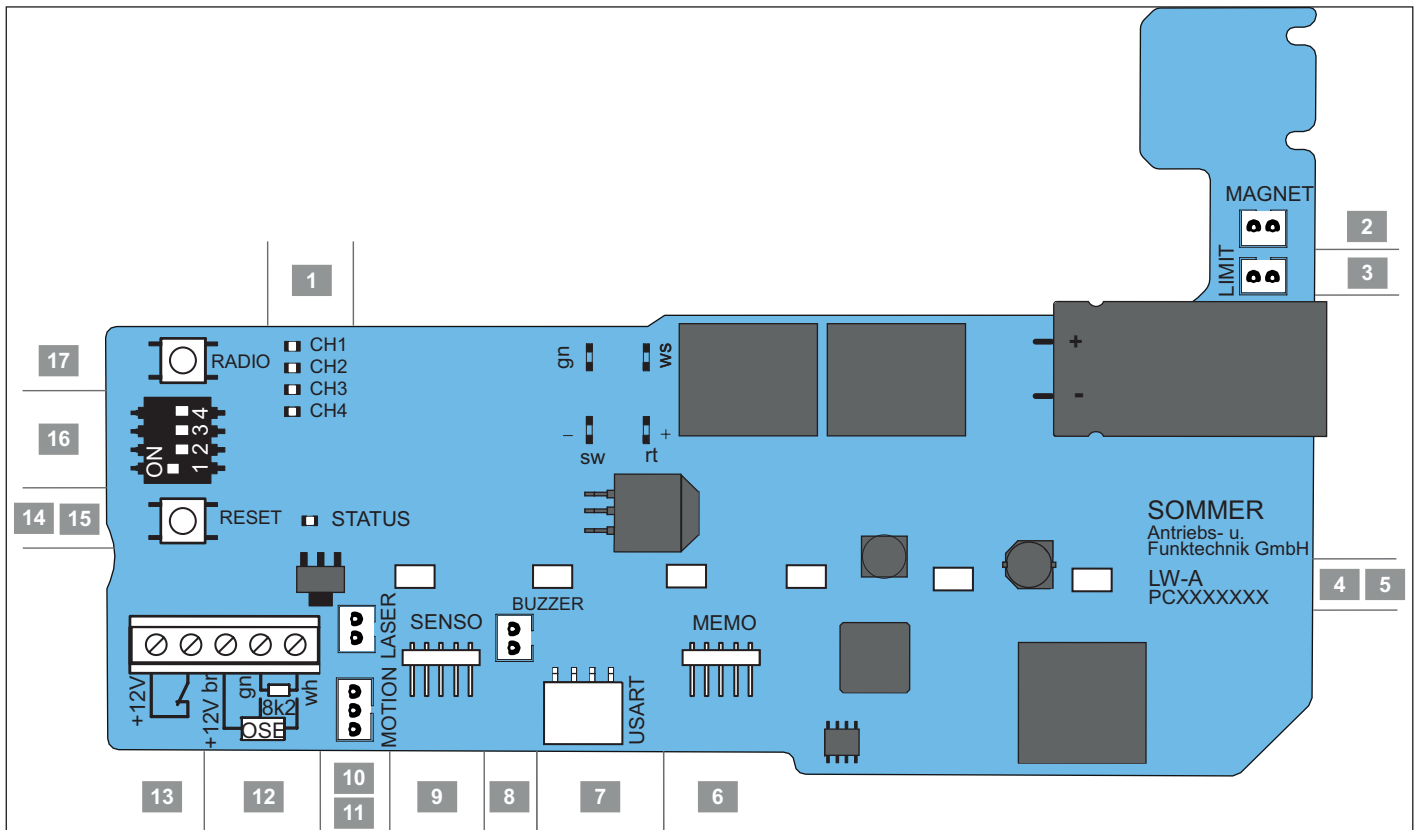

Fig. Motor carriage circuit board



#### Overview of connection options

1	LED, CH 1–4, red Display for radio channel	10	LASER slot, white, 2-pin Parking position laser terminal
2	MAGNET slot, green, 2-pin Lock terminal	11	MOTION slot, white, 3-pin Terminal for movement sensor
3	LIMIT slot, blue, 2-pin Limit stop terminal (OPEN)	12	Terminal for safety contact strip 8k2 OSE
4	Circuit board label	13	Connection for wicket door contact potential-free
5	LEDs, operator lighting	12/13	Terminal DC +12 V, max. 100 mA
6	MEMO slot Memo terminal (red housing)	14	Status LED, green
7	USART slot Interface for additional modules	15	Reset button, green
8	BUZZER slot, black, 2-pin Warning or alarm buzzer terminal	16	DIP switches
9	SENSO slot Senso terminal	17	Radio button, red

A connection diagram can be found in Chapter “18. Connection diagrams and functions of the DIP switches for tiga.”

# 10. Connections and special functions of the motor carriage

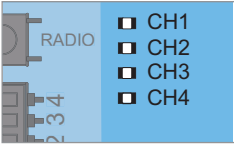
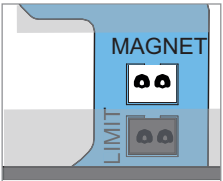
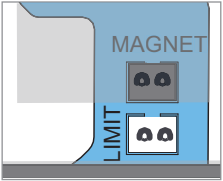
## 10.2 Connection options on the motor carriage

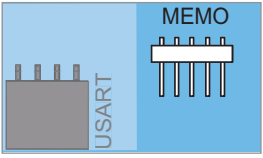
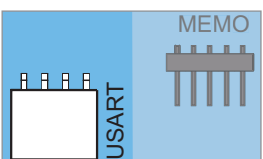
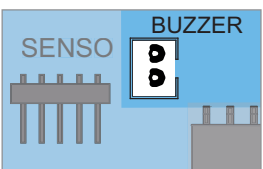
Circuit board section	Function/application example
<b>1</b> Radio channels, CH 1–4, red 	
<b>2</b> MAGNET slot*, green, 2-pin 	Lock terminal, locking magnet
<b>3</b> Limit slot 	
<b>4</b> Circuit board label 	
<b>5</b> Operator lighting, 6 LEDs 	
<b>6</b> MEMO slot* 	Memo terminal (red housing) Memory extension for 450 transmitter commands
<b>7</b> USART slot 	Terminal Interface for additional modules
<b>8</b> BUZZER slot*, black, 2-pin 	Warning or alarm buzzer terminal

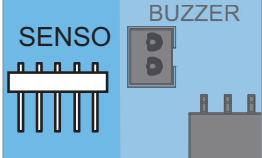
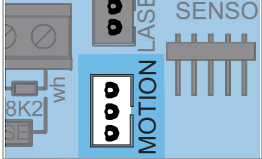
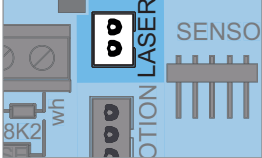
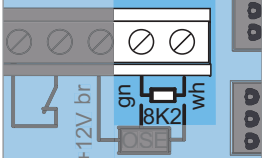
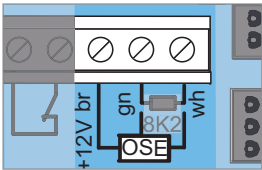
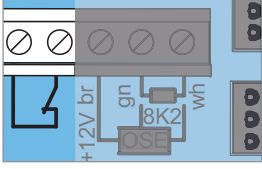
Circuit board section	Function/application example
<b>9</b> SENSO slot* 	Terminal for Senso humidity sensor
<b>10</b> MOTION slot*, white, 3-pin 	Terminal for Motion movement sensor
<b>11</b> LASER slot*, white 	Terminal for Laser parking position laser
<b>12.1</b> Terminal for safety contact strips 	8k2
<b>12.2</b> 	OSE +12 V = br Signal = gr GND = wh
<b>13</b> Wicket door contact connection 	Wicket door switch, reed contact etc. potential-free Contact command DC +12 V, 10 mA, normally closed contact

## 10. Connections and special functions of the motor carriage

### Circuit board section

### Function/application example

#### 12 12 V connection

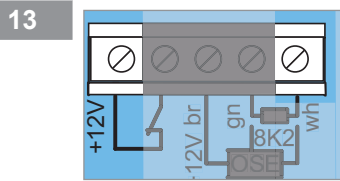

max. 100 mA, DC +12 V  
GND = wh  
Voltage supply for optional accessories  
e.g. finger scanner

#### 14 Status LED

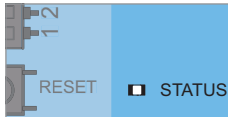

#### 15 Reset button

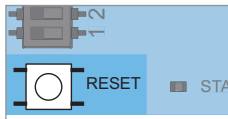

#### 16 DIP switches

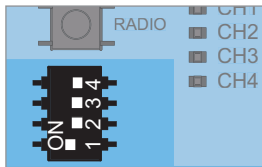

#### 17 Radio button

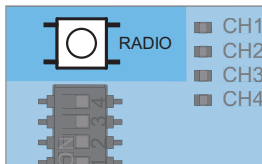

### DANGER



#### Danger due to electric current!

Contact with live parts may result in electric current flowing through the body. Electric shock, burns or death will result.

- ▶ All work on electrical components must be carried out by a **trained electrician**.
- ▶ Do not connect accessories unless the operator is disconnected from the power supply.
- ▶ Disconnect the mains plug before working on the operator.
- ▶ If an accumulator is connected, disconnect it from the control unit.
- ▶ Check that the operator is not live.
- ▶ Secure the operator against being switched back on.

### NOTE

- Do not use a metal object to set the DIP switches, because this may damage the DIP switches or the circuit board.

Use a suitable tool to set the DIP switches, such as a flat, thin plastic object.

## 10.3 Reducing the illumination power of LEDs

### WARNING



#### Danger due to optical radiation!

Looking into an LED at short range for an extended period may cause optical glare. This may temporarily reduce vision. This may cause serious or fatal accidents.

- ▶ Never look directly into an LED.

The illumination power of the LEDs of the operator lighting can be reduced during adjustment work on the motor carriage.

1. Press the Radio or Reset button once briefly.
  - ⇒ Illumination power of LEDs reduced.

## 10.4 Explanation of the radio channels

LED	Radio channel	Setting/function
1	CH 1	Multi-function relay, lighting
2	CH 2	Partial opening
3	CH 3	<b>Exterior</b> request side
4	CH 4	<b>Interior</b> request side

## 10.5 Programming the transmitter

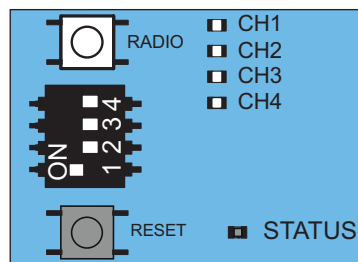

Fig. 1























### INFORMATION

- If no transmission command is received within 30 seconds of pressing the Radio button, the radio receiver switches to normal mode.

## 10. Connections and special functions of the motor carriage

1. Press the Radio button repeatedly to select the required channel.

	1x	2x	3x	4x
<b>LED</b>				
<b>CH 1</b>				
<b>CH 2</b>				
<b>CH 3</b>				
<b>CH 4</b>				

2. Press the desired button on the transmitter until the previously selected LED (CH 1, CH 2, CH 3, CH 4) goes out.
  - ⇒ LED goes out – programming is complete.
  - ⇒ The transmitter has transferred the radio command to the radio receiver.
3. Repeat the above steps to program additional transmitters.

### If the memory capacity has been reached

A total of 40 handheld transmitter commands are available for all channels. If an attempt is made to program additional transmitters, the red LEDs of radio channels CH 1–4 blink. If more memory positions are needed, see Chapter “10.6 Information on Memo”.

### 10.6 Information on Memo

The memory capacity can be extended to 450 handheld transmitter commands using the optional Memo accessory part. When the Memo is plugged in, all available transmitters are transferred from the internal memory to the Memo and stored there. The Memo must remain plugged in on the control unit.

No more transmitters are then stored in the internal memory. Stored transmitters cannot be transferred from the Memo back to the internal memory.

All radio channels, including the memory of the Memo, can be deleted; see Chapter “10.11 Deleting all radio channels in the receiver”.



#### INFORMATION





















- Only delete a Memo on which data has been stored on a new operator. Otherwise, all stored transmitters of an operator are deleted and must be reprogrammed.

### 10.7 Cancelling programming mode

1. Press the Radio button until all LEDs are off or make no input for 30 seconds.
  - ⇒ Programming mode is cancelled.

### 10.8 Deleting a transmitter button from the radio channel

1. Press the Radio button repeatedly to select the required radio channel.
  - Press and hold the Radio button for 15 seconds.

	1x	2x	3x	4x
<b>LED</b>				
<b>CH 1</b>				
<b>CH 2</b>				
<b>CH 3</b>				
<b>CH 4</b>				

- ⇒ The LED flashes after 15 seconds.
2. Release the Radio button.
    - ⇒ The radio receiver is now in deletion mode.
  3. Press the transmitter button for which the radio command is to be deleted in the radio channel.

- ⇒ LED goes out.
- ⇒ The deletion procedure is ended.

Repeat the process for additional buttons as required.

### 10.9 Deleting a transmitter completely from the receiver

1. Press and hold the Radio button for 20 seconds.
  - ⇒ The LED flashes after 15 seconds.
2. After another 5 seconds, the flash sequence changes to blinking.
3. Release the Radio button.
  - ⇒ The radio receiver is now in deletion mode.
4. Press any button on the transmitter that is to be deleted.
  - ⇒ LED goes out.
  - ⇒ The deletion procedure has been completed.
  - ⇒ The transmitter is deleted from the radio receiver.





















Repeat the process for additional transmitters as required.



# 10. Connections and special functions of the motor carriage

## 10.10 Deleting a radio channel in the receiver

- Press the Radio button repeatedly to select the required radio channel.  
Press and hold the Radio button for 25 seconds.

	1x	2x	3x	4x
<b>LED</b>				
<b>CH 1</b>				
<b>CH 2</b>				
<b>CH 3</b>				
<b>CH 4</b>				

- ⇒ The LED flashes after 15 seconds.
  - ⇒ After another 5 seconds, the flash sequence changes to blinking.
  - ⇒ After another 5 seconds, the LED of the selected radio channel remains steady.
- Release the Radio button.
    - ⇒ The deletion procedure is ended.
    - ⇒ All programmed transmitters on the selected radio channel are deleted from the radio receiver.

## 10.11 Deleting all radio channels in the receiver

- Press and hold the Radio button for 30 seconds.
  - ⇒ The LED flashes after 15 seconds.
  - ⇒ After another 5 seconds, the flash sequence changes to blinking.
  - ⇒ After another 5 seconds, the LED of the selected radio channel remains steady.
  - ⇒ After another 5 seconds, all LEDs light up.
- Release the Radio button.
  - ⇒ All LEDs are off after 5 seconds.
  - ⇒ **All programmed transmitters are deleted from the receiver.**
  - ⇒ **Receiver is completely deleted; this also applies if the Memo is plugged in.**

## 10.12 Programming a second handheld transmitter by radio (HFL)

### Prerequisites for programming by radio

A handheld transmitter must already be programmed on the radio receiver. The handheld transmitters used must be identical. This means, for example, that a Pearl can only be programmed on a Pearl and a Pearl Vibe on a Pearl Vibe.

The key assignment of handheld transmitter (A) that put the radio receiver into programming mode by radio is used for the new handheld transmitter (B) that is to be programmed. The already-programmed transmitter and the new transmitter to be programmed must be situated within the range of the radio receiver.

### Example:

- Button 1 has been programmed to radio channel 1 and button 2 to radio channel 2 by handheld transmitter (A).
  - ⇒ The newly programmed handheld transmitter (B) adopts the button assignment of handheld transmitter (A): Button 1 to radio channel 1 and button 2 to channel 2.

### Restrictions

- This function is not possible with the Pearl twin handheld transmitter.
- The targeted programming of a selected handheld transmitter button to a radio channel is not possible.

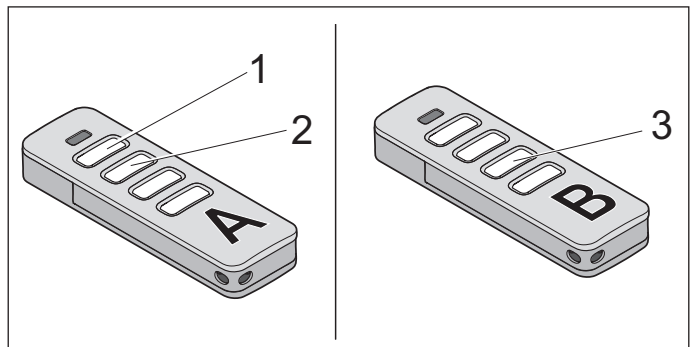

Fig. 1

- Press buttons 1 and 2 of a programmed handheld transmitter (A) for 3–5 seconds until the LED on the handheld transmitter briefly lights up.
  - ⇒ The operator lighting LEDs blink.
- Release buttons 1 and 2 of handheld transmitter (A).
  - ⇒ If no radio command is transmitted within another 30 seconds, the radio receiver switches over to normal mode.
- Press any button, e.g. (3) on the new handheld transmitter (B) to be programmed.
  - ⇒ The LEDs of the operator lighting remain steady.
  - ⇒ The second handheld transmitter (B) has been programmed.

# 10. Connections and special functions of the motor carriage

## 10.13 Carrying out a reset

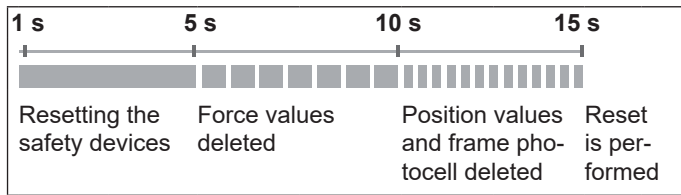

Fig. Overview of the time sequence of the motor carriage status LED when pressing the green Reset button

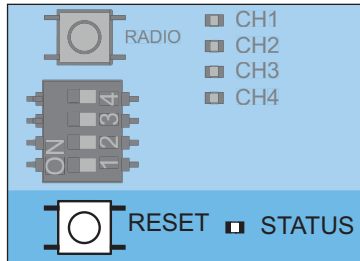

Fig. 1



### INFORMATION

- A SOMlink and a WiFi-enabled device are required to reset all parameters to the factory setting.
- The DIP switches can only be manually reset.

### Resetting the safety devices

1. Press the green Reset button for 1 second.
  - ⇒ Reset of the safety inputs.
  - ⇒ Subsequently attached safety inputs are detected.

### Deleting the force values

1. Press the green Reset button on the motor carriage for 5 seconds until the green status LED blinks slowly.
  - ⇒ Force values are deleted.

### Deleting force and position values

1. Press the green Reset button on the motor carriage for 10 seconds until the green status LED blinks quickly.
  - ⇒ Force and position values deleted.
  - ⇒ Frame photocell deleted.

### Resetting

1. Press the green Reset button on the motor carriage for 15 seconds until the green LED goes out.
  - ⇒ Reset is performed.

## 10.14 Setting the DIP switches on the motor carriage

Special functions can be set up with the DIP switches on the motor carriage.

For compliance with EN 13241, before initial operation, the door type must be selected and set on the motor carriage with DIP switches 3 or 4; see table below.

DIP switch on motor carriage	ON	OFF
1	<ul style="list-style-type: none"> <li>• Automatic closing function activated*</li> </ul>	<ul style="list-style-type: none"> <li>• Automatic closing function deactivated</li> </ul>
2	<ul style="list-style-type: none"> <li>• Partial opening activated</li> </ul>	<ul style="list-style-type: none"> <li>• Partial opening deactivated*</li> </ul>
3+4	<ul style="list-style-type: none"> <li>• No function</li> </ul>	<ul style="list-style-type: none"> <li>• Factory setting *</li> </ul>
3		
4		



\* Factory setting

## 10.15 Setting the automatic closing function

When automatic closing is activated, the door is opened by a pulse. The door moves to the door OPEN end position. The door closes automatically after the hold open time. With the factory settings, the door also closes automatically from the partial opening position when the automatic closing function is activated.

## 10. Connections and special functions of the motor carriage

### WARNING



#### Risk of injury during automatic closing!

Automatically closing doors can injure people and animals in the movement area of the door when the door is closing. Serious injury or death may result.

- ▶ Always keep the moving door in sight.
- ▶ Persons or animals must not be in the range of movement of the door.
- ▶ Never put your hand near the door or moving parts when it is moving. In particular, do not reach into the ceiling holder or the push arm.
- ▶ Do not drive through the door until it has been fully opened.

### NOTE

- If the door is not in view and the operator is actuated, objects in the movement area of the door may be jammed and damaged. Objects must not be in the range of movement of the door.

### INFORMATION

- The door opens completely if it hits an obstacle.
- Operation with automatic closing must comply with standard EN 12453: 2017 (Plc). This is a legal requirement. National regulations must be observed in non-European countries.
- A photocell/light curtain must be connected. Bridging the safety inputs with jumpers is not permitted.

### 10.16 Hold open time

The hold open time is the time during which the door remains open after reaching the door OPEN end position until it automatically closes.

During the hold open time, the request side, which gave the open command, receives no light signal. The hold open time is restarted after every additional command.

#### Example:

If a command is sent while the operator is closing automatically, it opens completely and the hold open time is reset.

#### Different hold open times

- In the factory setting, the hold open time is 60 seconds from the end position and from partial opening.
- When driving through the photocell/light curtain, the hold open time is shortened to 5 seconds.

1. The door OPEN end position is reached by pressing button 1 on the transmitter. Every additional command issued during the hold open time restarts the hold open time. The door movement cannot be stopped with the transmitter.
2. The door closes automatically after 60 seconds.
  - The closing movement can be stopped by a command with the transmitter.
  - ⇒ Door opens completely – after reversal of direction.
3. The door starts the closing process again after 60 seconds.
  - ⇒ The door moves to the door CLOSE end position.

### 10.17 Setting the hold open time manually

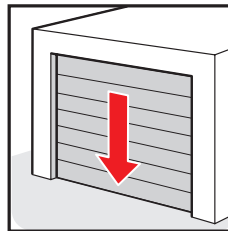

1. Close the door.

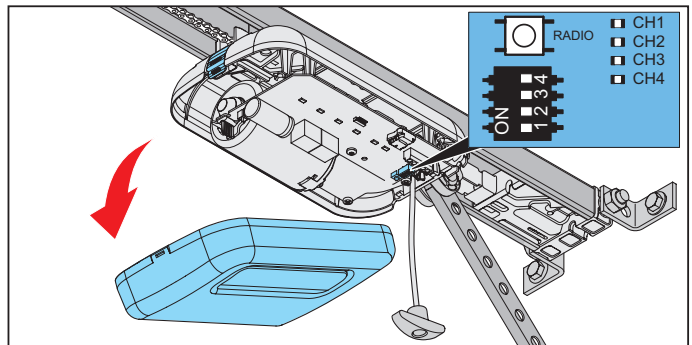

2. Remove the cover of the motor carriage.

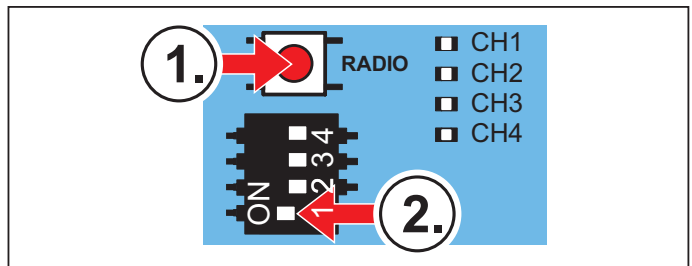

3. First, press and hold the Radio button. With the button pressed, set DIP switch 1 to "ON" position.
  - ⇒ LEDs CH 1 + CH 3 and CH 2 + CH 4 light up alternately in pairs for one second in each case. With each alternation, the hold open time has been extended by one second.

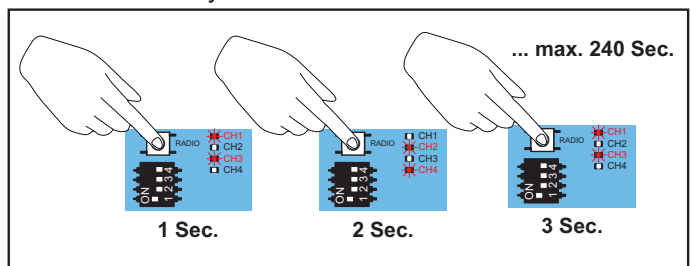

4. Count off the hold open time by counting the alternations of the LEDs. Release the Radio button when the desired duration has been reached.

## 10. Connections and special functions of the motor carriage

### 10.18 Pre-warning time

In the pre-warning time, the traffic light lights up red on both sides before the opening or closing of the door. The warning light and the operator lighting of the motor carriage also blink. No pre-warning time is activated in the factory settings.

### 10.19 Priority switching

Priority switching is used when entry from the exterior request side has a higher priority than that from the interior request side – for the exit. For example, when there is a very short entry and the car protrudes into the street. No priority switching is activated in the factory settings.

If the interior request side has drive authorisation and a command comes from the exterior request side, the interior drive authorisation is terminated. After the clearing time (factory setting 10 seconds), the exterior request side receives drive authorisation. The traffic light in the interior lights up red.

### 10.20 Shortened hold open time for driving through the photocell

This is preset at the factory for sectional doors and side-opening sectional doors. When driving through, the photocell is activated, and the hold open time is shortened to 5 seconds for sectional doors and side-opening sectional doors.

If DIP switch 4 is set to ON (one piece doors) on the motor carriage, the shortened hold open time after driving through the photocell is not available in the factory setting.

- ⇒ Door is in the door OPEN end position.
- ⇒ A vehicle drives through the photocell.  
Shortening of the hold open time is now activated.  
Door closes 5 seconds after the photocell is driven through.

### 10.21 Clearing time

The 10-second clearing time (factory-set) starts after the hold open time runs out. During clearing time, the traffic lights light up red and the operator lighting on the motor carriage also blinks.

Persons or vehicles which had access authorisation on the request side (interior/exterior) must clear the entrance during this time.

### 10.22 12 V output

This output can be used for the voltage supply of external accessories. DC 12 V, max. 100 mA are available for them.

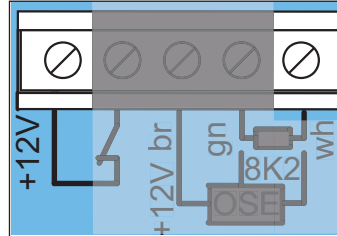

Fig. 12 V output

Terminal block	Function
br = DC +12 V	Output DC 12 V,
wh = GND	max. 100 mA

External devices can be connected in this operating mode, for example a finger scanner on the door panel. In this operating mode, power-saving mode is not available and must be deactivated; see Chapter “13.5 Power-saving mode”.



#### INFORMATION

- Power-saving mode must be deactivated for this operating mode. To do this, set DIP switch 3 on the wall control unit to ON.

### 10.23 Setting partial opening

A desired door opening can be selected with this function, e.g. for access for persons. The door will then not open completely, but only to the set door OPEN end position. The specified partial opening can be approached from any position of the door.



#### INFORMATION

- When the door has reached the partial opening position, the traffic lights light up red on both sides of the door.

1. Close the door completely up to the door CLOSE end position.
2. Press the Radio button repeatedly to select radio channel CH 2 and to program the partial opening function to the desired transmitter button.
3. Set DIP switch 2 on the motor carriage to ON.
4. Press the desired button on the transmitter for the partial opening function.
  - ⇒ The door moves in door OPEN direction.
5. When the door reaches the desired partial opening position, press the button on the transmitter again.
  - ⇒ The door stops at the desired position.
  - ⇒ The partial opening position is programmed.

# 10. Connections and special functions of the motor carriage

## 10.24 Deleting partial opening

1. Set DIP switch 2 on the motor carriage to OFF.
2. Open the door completely up to the door OPEN end position.  
⇒ Partial opening is deleted.

To program a new position, see Chapter “10.23 Setting partial opening”.

## 10.25 Wicket door safety device

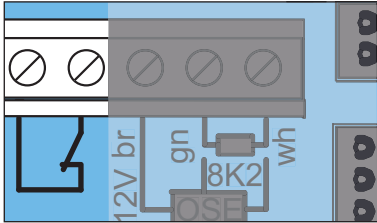

Fig. Connection of wicket door safety device

The wicket door safety device prevents operation of the door with an open wicket door. The wicket door safety device from **SOMMER** meets the requirements of EN 12453:2017 (Plc). Only the **SOMMER** wicket door switch, Item No. S11474-0001, may be connected.

1. The wicket door safety device must be installed so that the switch reliably detects the open door. Do not install the wicket door safety device on the hinge side. See also the separate instructions for the “Wicket door”.
2. Connect the wicket door safety device to the terminal block on the motor carriage. The contact command is at DC 12 V, 10 mA. The normally closed contact is potential-free.
3. Check the function of the wicket door safety device.

### **i** INFORMATION

- If the control unit receives a new command with the wicket door open, the LEDs of the operator lighting change from permanent to blinking light.

## 10.26 Connecting the safety contact strip

Either an OSE (opto-electronic safety contact strip) or an 8k2 (electric safety contact strip) can be connected. During commissioning, the control unit automatically detects which version it is and sets itself to that version. If a safety contact strip is retrofitted on a programmed system, the control unit must be reset; see Chapter “10.13 Carrying out a reset”. As set at the factory, the safety contact strip is only effective in the Close direction. The direction of action can be changed with the SOMlink.

Terminal block	8k2
	gn wh

Terminal block	OSE
	+12 V = br OSE = gn GND = wh

The safety contact strip in the door CLOSE direction of motion is triggered:

- ⇒ Operator stops and opens the door slightly.
- ⇒ The obstacle is released.

### **i** INFORMATION

- In automatic closing operating mode, the operator stops and opens the door completely. The door closes automatically after the hold open time. If the door encounters the obstacle again, the operator stops and reverses completely to the door OPEN end position. The door stops there and the automatic closing function is interrupted. The hold open time does not start again until a command is received. The door is then automatically closed.

## 10.27 SOMlink

SOMlink is a combination of an additional device and a web-based application. Since safety-relevant values can also be changed, SOMlink is only sold to **qualified specialists**. SOMlink makes it possible for **qualified specialists only** to change functions and settings on the operator. These include force and speed values as well as operating parameters and other convenient functions. All changes to settings via the SOMlink are logged.

You can access a demo version of the WEB APP under: [https://www.sommer-projects.de/gta\\_app/#home](https://www.sommer-projects.de/gta_app/#home)

### **i** INFORMATION

- A SOMlink and a WiFi-enabled device are required to reset all parameters to the factory setting.
- The DIP switches can only be manually reset.

# 11. Connections and special functions of the wall control unit

## 11.1 Wall control unit circuit board

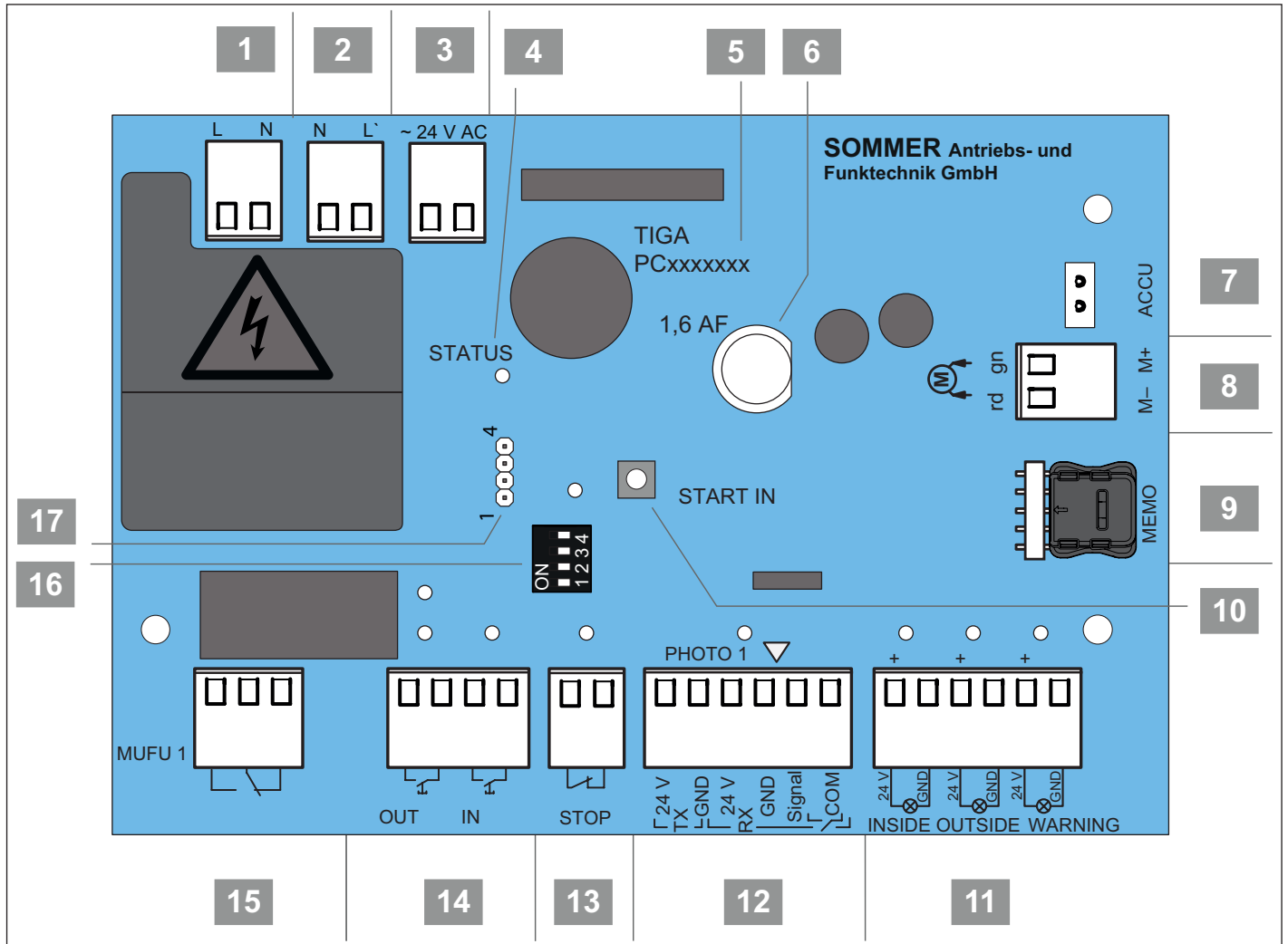

Fig. Wall control unit circuit board

# 11. Connections and special functions of the wall control unit

## Overview of connection options

1 2-pin terminal block

### Supply voltage

AC 220–240 V, 50–60 Hz

2 2-pin terminal block

### Primary side transformer

AC 220–240 V, 50–60 Hz

3 2-pin terminal block

### Secondary side transformer

AC 24 V

4 **Status LED**

with status LED, green

5 **Circuit board label**

6 **Glass fuse 1.6 AF**

7 **ACCU slot**

Terminal for battery pack

8 2-pin terminal block

### Chain and rail

DC 24 V

9 **MEMO slot**

Memo tiga (black housing)  
mounted at the factory

10 **Start IN**

Start button for interior

11 **Terminal block, 6-pin**

- **Traffic light for red**, interior, with status LED, red, DC 24 V, max. 7 W
- **Traffic light for red**, exterior, with status LED, red, DC 24 V, max. 7 W
- **Warning light**, with status LED, orange, DC 24 V, max. 3 W

12 **PHOTO 1 terminal block, 6-pin**

2- or 4-wire photocell (door CLOSE direction)  
DC 24 V, max. 100 mA,  
with status LED, orange

**or**

Light curtain with OSE output  
(door CLOSE direction)

DC 24 V = br

GND = wh

Signal = gn

13 **STOP terminal block, 2-pin**

potential-free, e.g. for EMERGENCY STOP  
with status LED, green

14 **IN/OUT button terminal block, 4-pin**

potential-free

- interior request side
- exterior request side with status LED, orange

15 MUFU 1 terminal block

### Multi-function relay 1

Potential-free changeover contact  
max. AC 250 V, 5 A or DC 24 V, 5 A  
with status LED, green

16 **DIP switches**

17 **Relay slot**

Switching capacity max. AC 250 V, 5 A or  
max. DC 24 V, 5 A  
with status LED, green

A connection diagram can be found in Chapter  
“18. Connection diagrams and functions of the DIP  
switches for tiga”.

# 11. Connections and special functions of the wall control unit

## 11.2 Connection options to the wall control unit

Circuit board section	Function/application example
<b>1</b> Terminal block, supply voltage, 2-pin	AC 220–240 V, 50–60 Hz
<b>2</b> Terminal block primary side transformer, 2-pin	AC 220–240 V, 50–60 Hz
<b>3</b> Terminal block secondary side transformer, 2-pin	AC 24 V
<b>4</b> Status LED, green	
<b>5</b> Circuit board label	
<b>6</b> Glass tube fuse	
<b>7</b> Accu slot	Terminal for battery pack

Circuit board section	Function/application example
<b>8</b> Terminal block, chain and rail, 2-pin	DC 24 V gn + = rail rd - = chain
<b>9</b> MEMO slot	<b>Memo tiga (black housing)</b> mounted at the factory EEPROM for configuration data from multi-function relay 1 (MUFU 1 and optional relay)
<b>10</b> Start button for interior	with status LED, green
<b>11</b> Terminal block traffic light and warning light, 6-pin	<b>Traffic light for red, interior</b> DC 24 V, max. 7 W with status LED, red
	<b>Traffic light for red, exterior</b> DC 24 V, max. 7 W with status LED, red
	<b>Warning light, 2-pin</b> DC 24 V, max. 3 W with status LED, orange

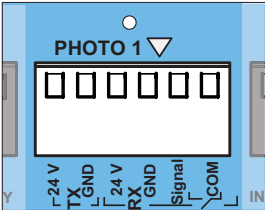
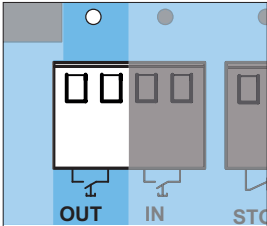
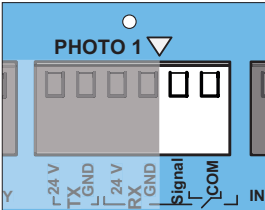
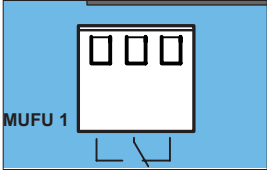
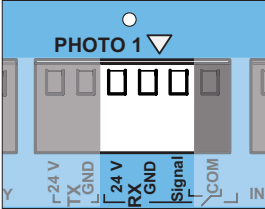
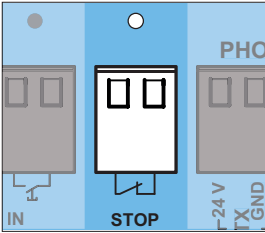
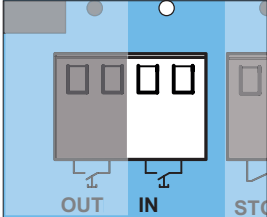
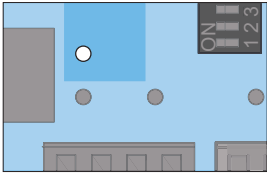
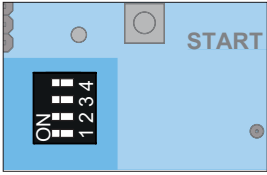
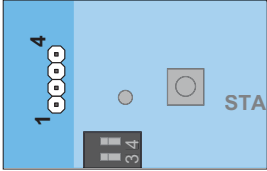

# 11. Connections and special functions of the wall control unit

Circuit board section	Function/application example	Circuit board section	Function/application example
<b>12</b> Terminal block for PHOTO 1, 6-pin 	<b>4-wire photocell for door CLOSE</b> <b>TX (transceiver)</b> DC +24 V GND <b>RX (receiver)</b> DC +24 V GND Signal COM potential-free DC 24 V, max. 100 mA with status LED, orange	<b>14</b> Terminal for interior and exterior button, 4-pin 	<b>Button OUT for exterior</b> potential-free with status LED, orange
	<b>2-wire photocell (SOMMER for door CLOSE), 2-pin</b> Signal COM Any polarity with status LED, orange		<b>15</b> MUFU 1 terminal block, 3-pin Potential-free changeover contact max. DC 250 V, 5 A or max. AC 24 V, 5 A with status LED, green
	<b>Light curtain with OSE output for door CLOSE</b> DC +24 V, max. 100 mA GND Signal		<b>13</b> STOP terminal block, 2-pin potential-free e.g.: for EMERGENCY STOP with status LED, green
			<b>14</b> Button IN for interior, 2-pin potential-free with status LED, orange
			<b>15</b> MUFU 1 terminal block, 3-pin Potential-free changeover contact max. DC 250 V, 5 A or max. AC 24 V, 5 A with status LED, green
			<b>16</b> DIP switches
			<b>17</b> Relay slot Switching capacity max. AC 250 V, 5 A or max. DC 24 V, 5 A

# 11. Connections and special functions of the wall control unit

## ⚠ WARNING



### Danger of crushing and shearing!

- The door can be actuated by a button. Persons who cannot see the door and are in the range of movement of the mechanism or the safety edges may be injured by crushing or shearing.
- ▶ Keypads and other command devices may only be installed within view of the door.
  - ▶ Only use keypads or other command devices when you can see the movement of the door.
  - ▶ All danger zones must be visible during the entire door operation.
  - ▶ Always keep the moving door in sight.
  - ▶ Keep persons and animals clear of the range of movement of the door.
  - ▶ Never stand under the opened door.

## ⚠ WARNING



### Danger due to hot surfaces!

- After frequent operation, parts of the motor carriage or the control unit may become hot. If the control unit cover is removed and hot parts are touched, they may cause burns.
- ▶ Allow the operator to cool down before removing the cover.

## NOTE

- Never lay the control cable along a power line as this could cause interference in the control unit. Note the length of the control cable and install it correctly.
- Do not use a metal object to set the DIP switches, because this may damage the DIP switches or the circuit board. Use a suitable tool to set the DIP switches, such as a flat, thin plastic object.



## INFORMATION

- The control unit detects a short-circuit between chain and rail and then switches the operator off. If the short circuit is no longer present, the operator runs normally again.
- Control or regulating units in a fixed position must be mounted within sight of the door and at a height of at least 1.5 m.
- The power cord is approx. 0.7 m long.
- The maximum cable length for connected accessories is 25 m.

## 11.3 Setting DIP switches on the wall control unit

Special functions can be set with the DIP switches on the wall control unit.

DIP switches on the wall control unit	ON	OFF
	<ul style="list-style-type: none"> <li>• Both red traffic lights are <b>on</b> when the door is closed</li> </ul>	<ul style="list-style-type: none"> <li>• Both red traffic lights are <b>off</b> when the door is closed</li> </ul>
	<ul style="list-style-type: none"> <li>• No function</li> </ul>	<ul style="list-style-type: none"> <li>• No function</li> </ul>
	<ul style="list-style-type: none"> <li>• Continuous power to the complete system activated</li> </ul>	<ul style="list-style-type: none"> <li>• Power-saving mode activated</li> </ul>
	<ul style="list-style-type: none"> <li>• No function</li> </ul>	<ul style="list-style-type: none"> <li>• No function</li> </ul>

## 11.4 Information on Memo tiga

At the factory, the Memo tiga (black housing) is attached to the wall control unit in the Memo slot. It creates the configuration memory for the multi-function relay settings. Separate settings can be made in this way.

1. Disconnect the operator from the mains voltage. Check it is disconnected from the power supply.
2. Open the wall control unit; see Chapter “7.2 Cover of the wall control unit”.

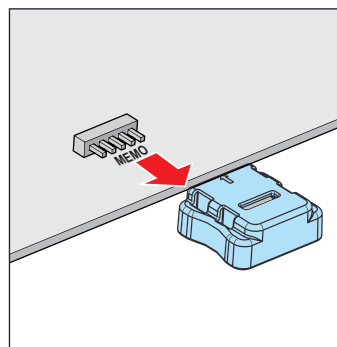

Fig. 3

# 11. Connections and special functions of the wall control unit

3. Remove the Memo tige from the wall control unit circuit board; see Chapter “11.1 Wall control unit circuit board”.

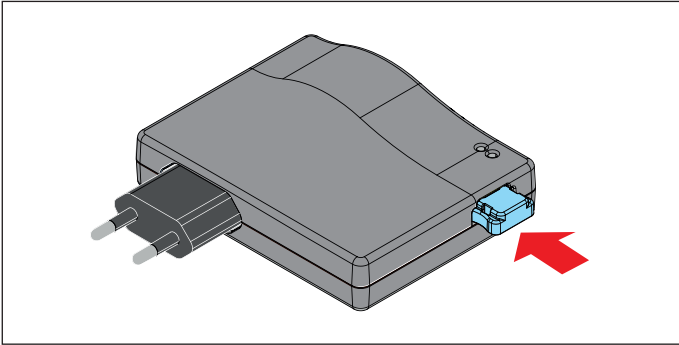

Fig. 4

4. Plug the Memo tige into the slot provided on the SOMlink.
5. Connect the SOMlink to the mains voltage.
6. Establish a connection to SOMlink with a WiFi-enabled device; see separate SOMlink instructions.
7. Select and confirm the Memo tige icon via the WiFi-enabled device.
8. Select the corresponding multi-function relay. Select and confirm the desired functions.
9. Disconnect the SOMlink from the mains voltage.

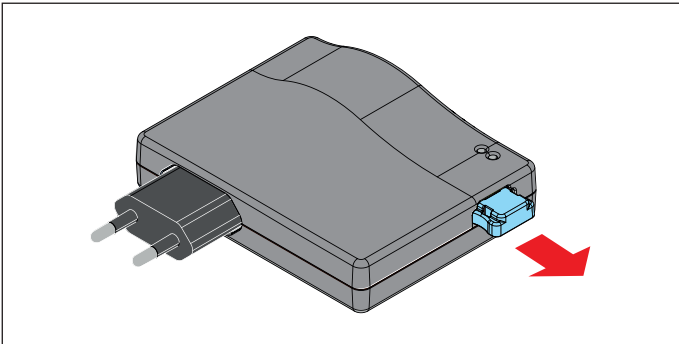

Fig. 10

10. Unplug the Memo tige from the SOMlink.

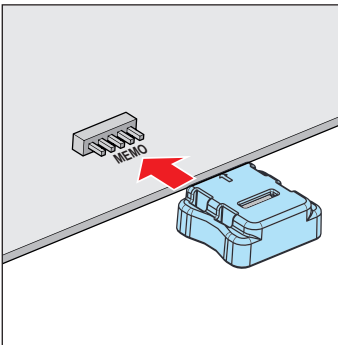

Fig. 11

11. Attach the Memo tige to the wall control unit circuit board. The Memo tige must remain plugged in to carry out the selected functions.
12. Close the wall control unit; see Chapter “7.2 Cover of the wall control unit”.
13. Connect the operator to the mains voltage. Check that the voltage supply is connected.
14. Check the settings made and adjust them if necessary.

## 11.5 Multi-function relay 1 – MUFU 1

The MUFU 1 multi-function relay 1 can be used for various functions, such as additional exterior lighting or a door status display.

In the factory setting, the multi-function relay is energised for:

- door closed/not closed.

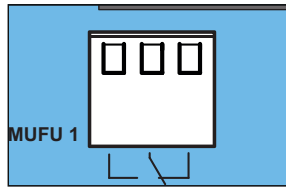

Fig. LED for MUFU 1

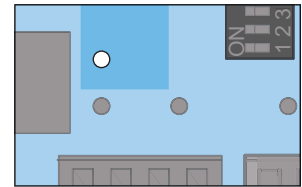

Fig. MUFU 1

The status LED for MUFU 1 lights up green when the relay is energised.

The multi-function relay 1 contact is a potential-free changeover contact and may only be loaded with max. AC 250 V, 5 A or max. DC 24 V, 5 A.

The door status display function is activated in the factory settings:

- ⇒ During door movement and if the door is open, multi-function relay 1 trips.
- ⇒ When the door CLOSE end position is reached, multi-function relay 1 is deactivated.

# 11. Connections and special functions of the wall control unit

## 11.6 Relay

An additional multi-function relay can be attached at the Relay slot. Additional functions can be activated, e.g. exterior lighting or the door status display (door closed/door not closed). The relay is an optional accessory.

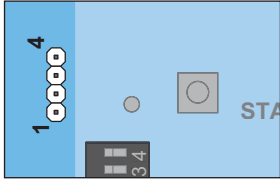

Fig. Relay slot

The “Pulse for 1 second at function change when starting motor” function is set at the factory.

- ⇒ When the operator is started, the relay is energised for 1 second.

## 11.7 Photocell and frame photocell

A 2-wire or 4-wire photocell from **SOMMER** can be connected to the control unit. The control unit automatically detects which version it is and sets itself to that version. We recommend installing the photocell at a height of up to 300 mm.



### INFORMATION

- If a photocell is retrofitted on a programmed system, the control unit must be reset; see Chapter “10.13 Carrying out a reset”.
- During initial operation of the photocell or the frame photocell, it must not be triggered by persons or objects.
- If a photocell is used as a frame photocell on the door, move the door to the centre position.

### 2-wire photocell for door CLOSE (PHOTO 1)

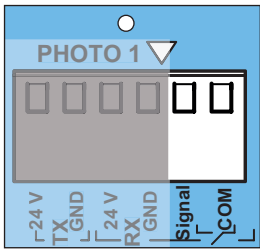

Fig. Terminal block for a 2-wire photocell

Connect the 2-wire photocell to the PHOTO 1 terminal block. The polarity is optional. The status LED (PHOTO 1) for door CLOSE lights up orange when the safety device has been detected by the control unit.

Terminal block	Function
Signal	2-wire photocell, any polarity
COM	

The 2-wire photocell (PHOTO 1) is interrupted in the door CLOSE direction:

- ⇒ Status LED flashes orange during the interruption.
- ⇒ The operator stops gently and opens the door completely.
- ⇒ The door closes again automatically after the hold open and clearing time.

### 4-wire photocell for door CLOSE (PHOTO 1)

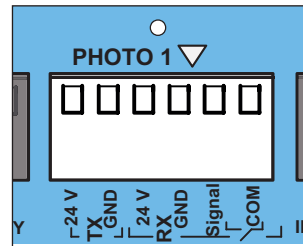

Fig. Terminal block for a 4-wire photocell

Connect the 4-wire photocell to the terminal block for door CLOSE (PHOTO 1). The supply for RX (Receiver) should be on the side facing away from the sun.

The status LED (PHOTO 1) for door CLOSE lights up orange when the safety device has been detected by the control unit.

	Terminal block	Function
TX (transceiver)	DC +24 V	Voltage supply
	GND	
RX (receiver)	DC +24 V	Floating relay contact
	GND	
	SIGNAL	
	COM	

The photocell (PHOTO 1) is interrupted in the door CLOSE direction:

- ⇒ Status LED flashes orange during the interruption.
- ⇒ The operator stops gently and opens the door completely.
- ⇒ The door closes again automatically after the hold open and clearing time.

### Use as frame photocell

1. Install the frame photocell in the frame; see separate instructions for “**Frame photocell**”.
2. Align the frame photocell and connect it to the wall control unit.

# 11. Connections and special functions of the wall control unit

3. Initial operation is performed as described in Chapter “9. Initial operation”.
  - ⇒ When the door passes the frame photocell, the illumination power of the operator lighting is reduced.
    - If the illumination power is not reduced, the frame photocell must be realigned and the control unit must be reset.
  - ⇒ During initial operation, the operator learns the exact position of the frame photocell in order to blank it out in normal mode shortly before reaching the door.
4. Check the frame photocell function. Repeat the process if necessary.

## 11.8 Connecting the light curtain

A 2-wire photocell from **SOMMER** or a light curtain (with **OSE output**) can be connected to the wall control unit connection for (door CLOSE – PHOTO 1); see Chapter “11. Connections and special functions of the wall control unit” or “18. Connection diagrams and functions of the DIP switches for tigo”.

### NOTE

- Installation of a light curtain (with **OSE output**) on the wall control unit must be carried out by a **trained electrician**.
- The manufacturer’s **installation and operating manual** must be strictly observed when installing the light curtain.
- There may be various connection options (depending on the specific light curtain/manufacturer).
- **Before purchasing** a light curtain, get expert advice from a **specialist retailer** on possible use and installation.

In particular, observe the warnings below.

### DANGER



- Danger due to electric current!**  
Contact with live parts may result in electric current flowing through the body. Electric shock, burns or death will result.
- ▶ All work on electrical components must be carried out by a **trained electrician**.
  - ▶ Do not connect the power supply until installation is complete.
  - ▶ Disconnect the mains plug before working on the operator.
  - ▶ If an accumulator is connected, disconnect it from the control unit.
  - ▶ Check that the operator is not live.
  - ▶ Secure the operator against being switched back on.

### NOTE

- To prevent damage to the operator, do not connect the wall control unit to the mains voltage until installation is complete.

### INFORMATION

- All devices to be connected externally must have safe isolation of the contacts from the mains voltage supply in accordance with IEC 60364-4-41.
  - Wiring for external devices must be installed in accordance with IEC 60364-4-41.
  - All electrical wiring, including the control cable, must be firmly secured to prevent displacement.

### Light curtain for door CLOSE (PHOTO 1)

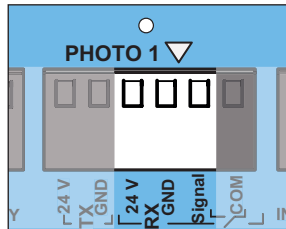

Fig. Connection of light curtain for door CLOSE

Connect the light curtain for door CLOSE to the terminal block (PHOTO 1).

The status LED lights up orange when the safety device has been detected by the control unit.

Terminal block	Function
br = DC +24 V	Voltage supply
wh = GND	
gn = SIGNAL	Signal input

The light curtain in direction door CLOSE (PHOTO 1):

- ⇒ Status LED blinks orange during the interruption.
- ⇒ The operator stops gently and opens the door completely.
- ⇒ The door closes again automatically after the hold open and clearing time.

### Use of the light curtain

1. Install the light curtain; see separate “**light curtain**” instruction manual from the respective manufacturer.
2. Align the light curtain and connect it to the wall control unit.
3. The manufacturer’s installation and operating manual must be strictly observed when installing the light curtain and during initial operation.
4. Check the function of the light curtain.
5. Connection to the mains voltage must not be established until installation has been completed. The connection to the accumulator is established last.

# 11. Connections and special functions of the wall control unit

## 11.9 Connection options for command devices

### IN button and OUT button

External command devices, for example pull buttons, buttons or key switches, can be connected to the control unit. A separate input is available for the interior and exterior request sides. The connection is potential-free.

#### IN button

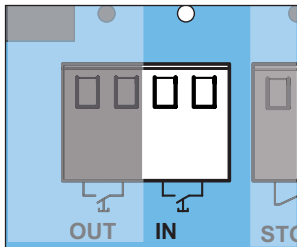

Fig. IN button

If the IN contact is activated, the command of the interior request side is executed:

- ⇒ Status LED lights up orange during activation.
- ⇒ Operator opens the door to the door OPEN end position.

**Interior:** Traffic light off.

**Exterior:** Red phase.

- ⇒ The door closes automatically after the hold open and clearing time.

#### OUT button

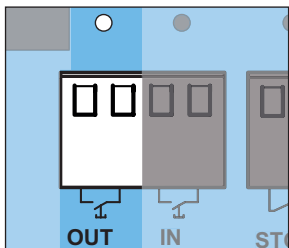

Fig. OUT button

If the OUT contact is activated, the command of the exterior request side is executed:

- ⇒ Status LED lights up orange during activation.
- ⇒ Operator opens the door to the door OPEN end position.

**Interior:** Traffic light off.

**Exterior:** Red phase.

- ⇒ The door closes after the hold open and clearing time have run out.

## 11.10 STOP connection

A potential-free NC contact can be connected to this terminal, for example an EMERGENCY STOP.

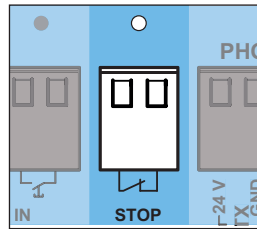

Fig. STOP access

The status LED for STOP lights up green when the contact is closed.

If the STOP safety input is open, the operator stops during the door movement. No more commands are executed.

- ⇒ Status LED on the control unit flashes.

### Resetting the STOP safety input

1. Reset safety input (close contact).
2. Execute a command using the button.
  - ⇒ Door opens up to door OPEN end position.
  - ⇒ The door closes automatically after the hold open and clearing time.

## 11.11 Installing and removing the battery pack

The battery pack can bridge approximately 5 cycles within 12 hours in the event of a power failure.

The battery pack can only be recharged for a limited number of cycles. This depends on the use and settings. Mains voltage is required for initial operation of the operator. If the factory settings are active, the door does not open if the battery is low. If DIP switch 4 on the wall control unit is set to ON, the door opens even if the battery is low. Only a **qualified electrician** is permitted to install, test and replace the battery pack. Observe the information in the separate “**Battery pack**” instructions.

# 11. Connections and special functions of the wall control unit

## Installing and connecting the battery pack

1. Disconnect the operator from the mains voltage.  
Check that the operator is disconnected from the power supply.

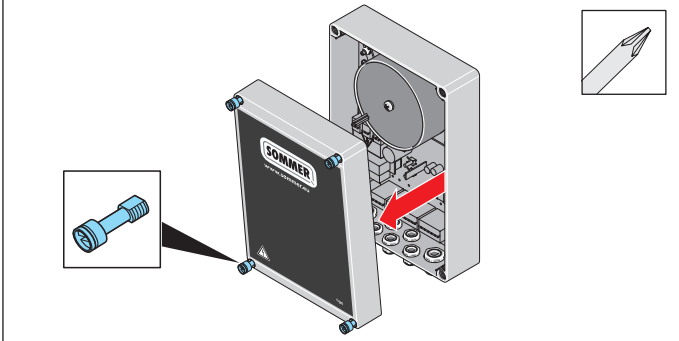

Fig. 2

2. Unscrew the screws on the control unit housing and remove the cover.

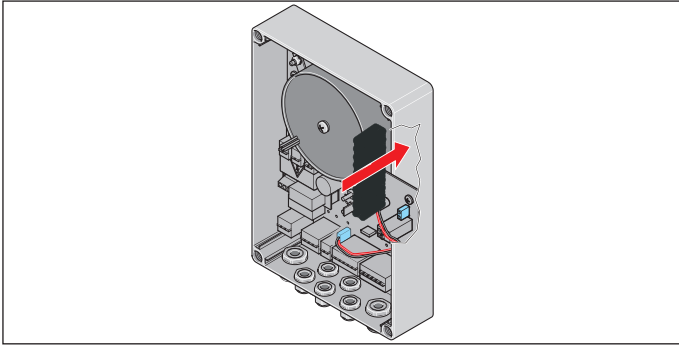

Fig. 3

3. Insert the battery pack into the provided position in the side of the control unit. If necessary, fasten the battery pack with the adhesive strips; see separate “**Battery pack**” instructions.

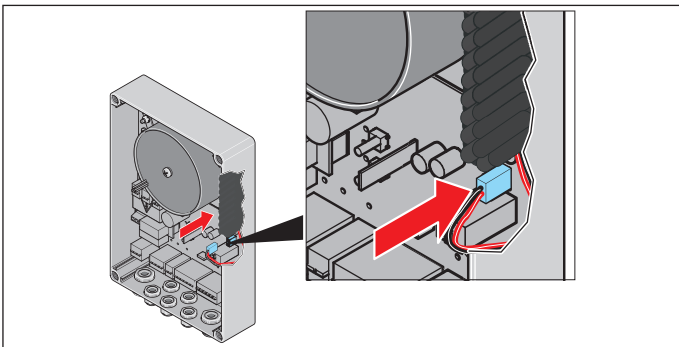

Fig. 4

4. Plug the connection cable into the battery pack and into the ACCU slot in control unit circuit board.
5. Supply the operator with mains voltage.  
Check that the voltage supply is connected.

## Unplugging and removing the battery pack

The battery pack is removed in the reverse order; see Chapter “11.11 Installing and removing the battery pack”, section “Installing and connecting the battery pack”.

### ⚠ WARNING



#### Danger of hazardous substances!

Improper storage, use or disposal of battery packs, batteries and operator components pose a risk to the health of humans and animals. Serious injury or death may result.

- ▶ Battery packs and batteries must be stored out of the reach of children and animals.
- ▶ Keep battery packs and batteries away from chemical, mechanical and thermal influences.
- ▶ Do not recharge old accumulators and batteries.
- ▶ Components of the operator as well as old battery packs and batteries must not be disposed of with household waste. They must be disposed of properly.

### ➔ NOTE

- Dispose of all components in accordance with local and national regulations to avoid environmental damage.



### INFORMATION

- Operator components that have been taken out of service as well as old accumulators and batteries must not be disposed of with household waste. Dispose of components which are no longer in use, old accumulators and batteries properly, in accordance with local and national regulations.



## 12. Function test/final test

### 12.1 Testing obstacle detection

After initial operation of the operator, the force setting of the operator must be checked with a force measurement device and an obstacle detection test must be performed. In particular, observe the warnings below.

#### WARNING



##### **Danger of entrapment!**

If the force setting is too high, persons or animals in the movement area of the door may be trapped and pulled along with the door. Severe injuries or death may result.

- ▶ The force setting is relevant to safety and must be carried out by a trained specialist.
- ▶ You must proceed with extreme caution if you check and if necessary adjust the force setting.
- ▶ Check the force setting at monthly intervals.



##### **Danger of entrapment!**

If the force setting is too high, persons or animals in the movement area of the door may be trapped by the door. Severe injuries or death may result.

- ▶ The obstacle recognition must be checked at monthly intervals and if necessary, set using an object with a height of 40 mm placed on the ground.



##### **Danger of crushing and shearing!**

If the door moves and there are persons or animals in the movement area, crushing and shearing injuries may be caused by the mechanism and safety edges of the door.

- ▶ Note that obstacle recognition does not operate below 40 mm.
- ▶ The obstacle detection must be tested once a month using an object with a height of 40 mm.
- ▶ Only use the operator when you have a direct view of the door.
- ▶ All danger zones must be visible during the entire door operation.
- ▶ Always keep the moving door in sight.
- ▶ Keep persons and animals clear of the range of movement of the door.
- ▶ Never put your hand near the door when it is moving or near moving parts. In particular, do not reach into the moving push arm.
- ▶ Do not reach into the ceiling suspension unit when the motor carriage is running along the rail.
- ▶ Do not drive through the door until it has opened completely.
- ▶ Never stand under the opened door.

#### NOTE

- Observe the national standards, guidelines and regulations for cut-off of the operating forces.
- The obstacle detection must be tested once a month to prevent damage to the operator.



#### INFORMATION

- After installation of the operator, the person responsible for the installation must complete an EC Declaration of Conformity for the door system in accordance with Machinery Directive 2006/42/EC and apply the CE mark and a type plate. This documentation and this Installation and Operating Manual must be handed over to the user.

This also applies if the operator is retrofitted to a manually operated door.

- **Reversing:** The operator stops on contact with an obstacle and then moves a short distance in the opposite direction to release the obstacle. In the automatic closing function, the door opens completely if an obstacle is detected.

After successful testing of the force setting, the obstacle detection and the functions, the **qualified specialist** must issue the EC Declaration of Conformity and attach the CE mark and type plate to the door system.

If it is possible for a person to be carried along with the (horizontally or vertically moving) door, it must be checked whether the operator is capable of lifting the weight of a person. The operator must reverse in the door OPEN direction when it is loaded with a weight of 20 kg. The weight is fastened in the centre of the bottom edge of the door for this purpose. This applies to doors with a door opening of over 50 mm.

The door must reverse during the door CLOSE movement if it hits an obstacle with a height of 40 mm on the ground.

1. Open the door with the operator.
2. Place a 40-mm-high object in the centre of the door.

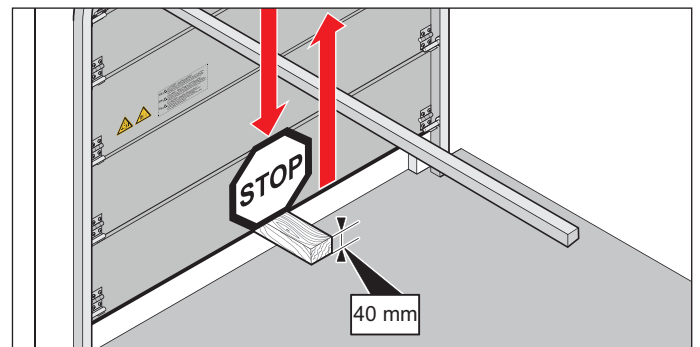

Fig. Example: Obstacle detection on sectional door



## 12. Function test/Final test

---

3. Close the door with the operator.
  - ⇒ If the door hits an obstacle, the operator must stop immediately and reverse.
  - ⇒ The operator opens the door completely at a pulse from the transmitter.
  - ⇒ If the operator does not reverse, a position reset is required; see Chapter “**10.13 Carrying out a reset**”.

The positions and the forces must be reprogrammed and tested by a trained specialist.
4. The function of the emergency release must be checked particularly in the door CLOSE end position and if necessary, also from outside. Unlocking must be possible; see Chapter “**13.7 Function of the emergency release**”.

### 12.2 Handover of the door system

You can find important information on handover to the user in Chapter “**1.10 Qualifications of personnel**”, section “**Instructing the user and handover of documents**”.

## 13. Operation

### 13.1 Important notes and information

In particular, observe the following warnings and Chapters “14. Maintenance and care” and “15. Troubleshooting”.

#### DANGER



##### **Danger if not observed!**

If warnings are not observed, serious injury or death may result.

- ▶ All warnings must be complied with.

#### WARNING



##### **Danger due to use of the operator with incorrect settings or when it is in need of repair!**

If the operator is used despite incorrect settings or if it is in need of repair, severe injury or death may result.

- ▶ The operator may only be used with the required settings and in the proper condition.
- ▶ You must have faults repaired professionally without delay.



##### **Danger due to falling parts of doors!**

Actuating the emergency release can lead to uncontrolled door movement if:

- springs are weakened or broken.
- the door has not been optimally weight-balanced.

Falling parts may cause a hazard. Severe injuries or death may result.

- ▶ Check the weight balance of the door at regular intervals.
- ▶ Pay attention to the movement of the door when the emergency release is actuated.
- ▶ Keep clear of the movement area of the door.
- ▶ Keep persons and animals clear of the range of movement of the door.



##### **Danger of entrapment!**

Persons or animals in the movement area of the door may be trapped and pulled along with the door. Severe injuries or death may result.

- ▶ Keep clear of the moving door.



##### **Danger of crushing and shearing!**

If the door moves and there are persons or animals in the movement area, crushing and shearing injuries may be caused by the mechanism and safety edges of the door.

- ▶ Only use the operator when you have a direct view of the door.
- ▶ All danger zones must be visible during the entire door operation.
- ▶ Always keep the moving door in sight.
- ▶ Keep persons and animals clear of the range of movement of the door.
- ▶ Never put your hand near the door when it is moving or near moving parts. In particular, do not reach into the moving push arm.
- ▶ Do not reach into the ceiling suspension unit when the motor carriage is running along the rail.
- ▶ Do not drive through the door until it has opened completely.
- ▶ Never stand under the opened door.



##### **Danger due to optical radiation!**

Looking into an LED at short range for an extended period may cause optical glare. This may temporarily reduce vision. This may cause serious or fatal accidents.

- ▶ Never look directly into an LED.



#### **NOTE**

- If the weight compensation of the door is incorrectly adjusted, the operator may be damaged.
  - The door must be stable.
  - It must not bend, rotate or twist when opening and closing.
  - The door must move easily in the rails.Defects must be repaired without delay by a **qualified specialist**.
- Objects in the movement area of the door may be jammed and damaged.
  - Objects must not be in the range of movement of the door.

### 13.2 Handover to the user

You can find important information on handover to the user in Chapter “1.11 Information for the user”.



#### **INFORMATION**

- Keep this Installation and Operating Manual accessible at all times at the place of use.

# 13. Operation

## 13.3 Operating modes of door movement

**⚠ WARNING**



**Danger of crushing and shearing!**

The door can be actuated by a keypad or another command device.

Persons who cannot see the door and are in the range of movement of the mechanism or the safety edges may be injured by crushing or shearing.

- ▶ Keypads or other command devices may be used only if the movement of the door can be viewed directly.
- ▶ Keep persons and animals clear of the range of movement of the door.
- ▶ Never stand under the opened door.

### Opening the door system from the interior and exterior

The sequence for a command from the exterior is described. Access authorisation for the interior and exterior is displayed by the traffic lights.

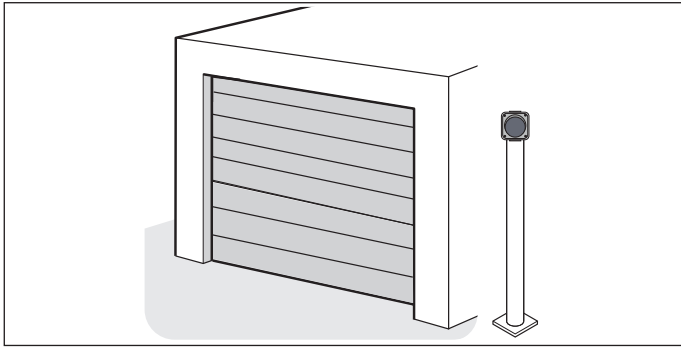

Fig. 1

1. The door is in the door CLOSE end position.  
**Both sides:** Traffic lights off.

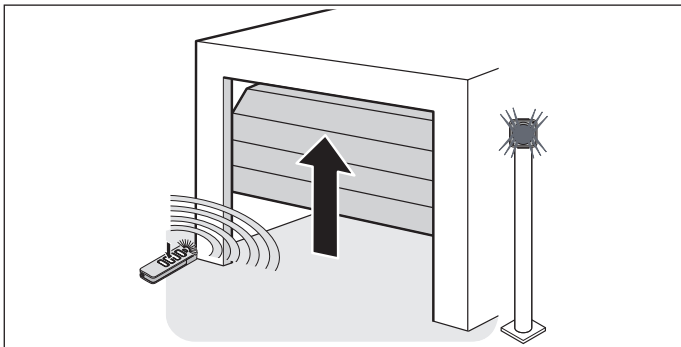

Fig. 2

2. A command from the interior or exterior (button, pull button or handheld transmitter) is given.  
⇒ **Both sides:** Red phase.  
Door may **not** be driven or passed through.  
⇒ Operator moves to door OPEN end position.

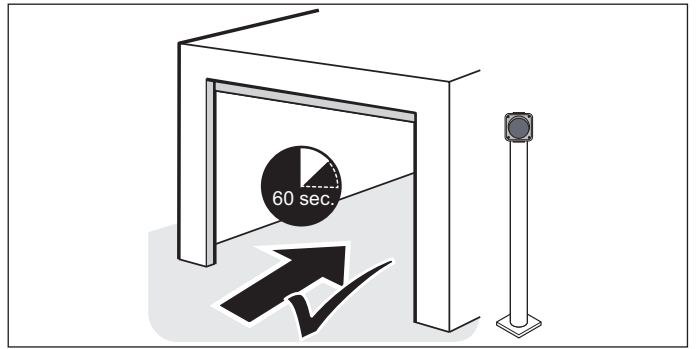

Fig. 3

3. The door is open. The set **hold open time** (factory setting 60 seconds) starts.

- ⇒ **Request side:** Traffic light off.  
Door may be driven or passed through.
- ⇒ **Opposite side:** Red phase.  
Door may not be driven or passed through.

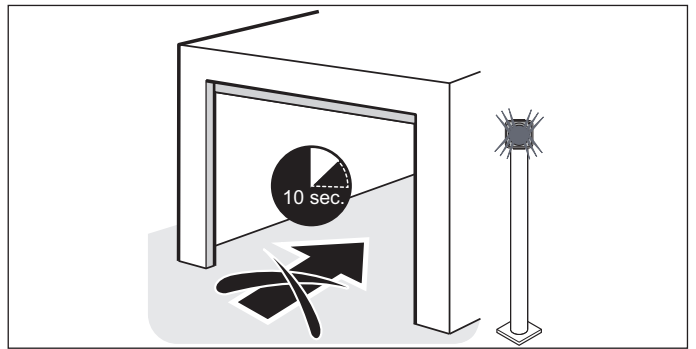

Fig. 4

4. The **clearing time** (factory setting 10 seconds) is automatically initiated after the set hold open time runs out.  
⇒ **Both sides:** Red phase.  
Door may **not** be driven or passed through.  
⇒ The door range must be cleared of persons and vehicles.

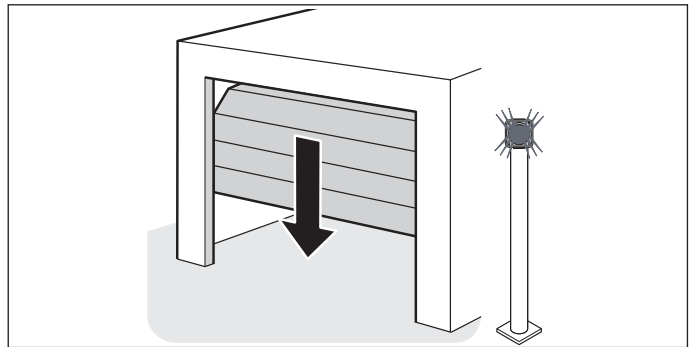

Fig. 5

## 13. Operation

5. The door closes automatically after the set clearing time.

⇒ **Both sides:** Red phase.

Door may **not** be driven or passed through.

⇒ The door range must be cleared of persons and vehicles.

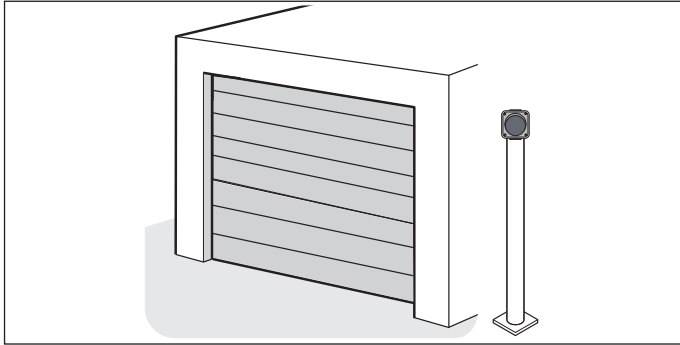

Fig. 6

6. After the door CLOSE end position has been reached, the traffic lights on both sides are switched off.

⇒ **Both sides:** Traffic lights off.



### INFORMATION

- If a command is given during the closing process, the operator stops. The direction changes automatically and the operator opens the door completely. The door closes automatically after the hold open and clearing time.

### Opening the door from the interior and subsequent command from the exterior

Access authorisation for the interior and exterior is displayed by the traffic lights.

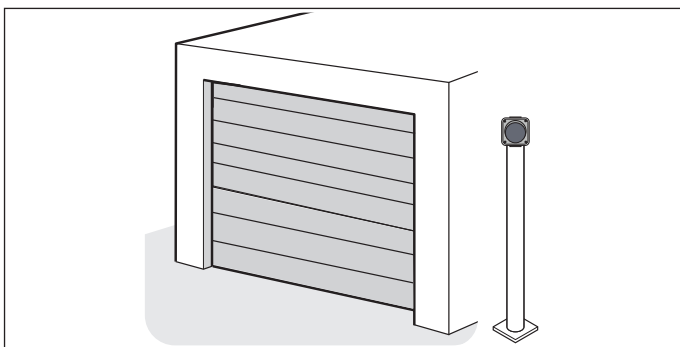

Fig. 1

1. The door is in the door CLOSE end position.

⇒ **Both sides:** Traffic lights off.

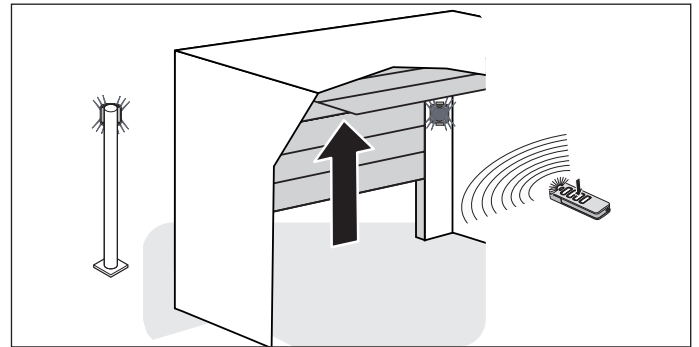

Fig. 2

2. A command (button, pull button or handheld transmitter) is given **from the interior**. While the door opens, an additional command is given **from the exterior**.

⇒ **Both sides:** Red phase.

Door may not be driven or passed through.

⇒ Operator moves to door OPEN end position.

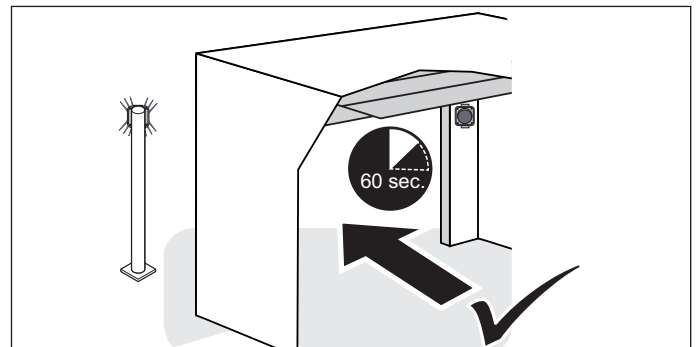

Fig. 3

3. The door is open. The set **hold open time** (factory setting 60 seconds) starts.

⇒ **Request side, interior:** Traffic light off.

Door may be driven or passed through.

⇒ **Opposite side, exterior:** Red phase.

Door may **not** be driven or passed through.

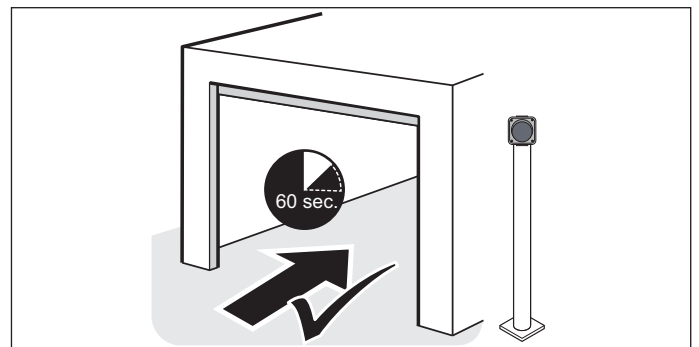

Fig. 4

## 13. Operation

4. After the set hold open time (factory setting 60 seconds) and clearing time (factory setting 10 seconds) for the interior, the traffic lights are **automatically** switched. The request side and the opposite side are then exchanged.

- ⇒ **Opposite side, interior:** Red phase.  
Door may not be driven or passed through.
- ⇒ **Request side, exterior:** Traffic light off.  
Door can be driven or passed through from the **exterior** request side.

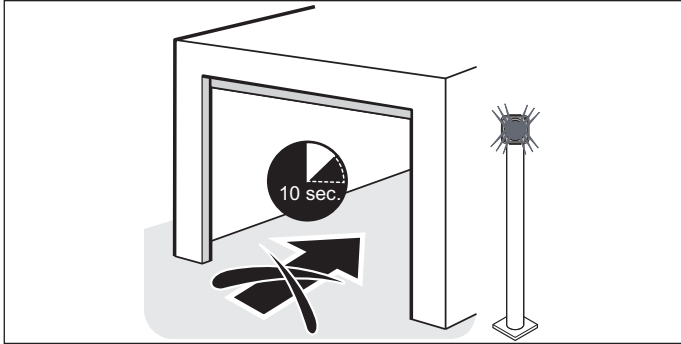

Fig. 5

5. The **clearing time** (factory setting 10 seconds) is automatically initiated after the set hold open time runs out.

- ⇒ **Both sides:** Red phase  
⇒ The entrance must be cleared of persons and vehicles.

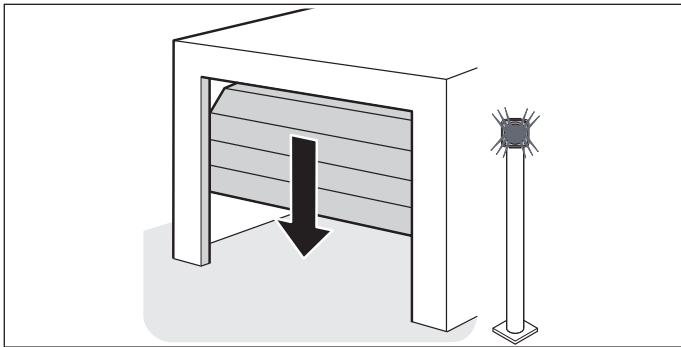

Fig. 6

6. The door closes automatically after the set clearing time.

- ⇒ **Both sides:** Red phase.  
Door may not be driven or passed through.
- ⇒ The entrance must be cleared of persons and vehicles.

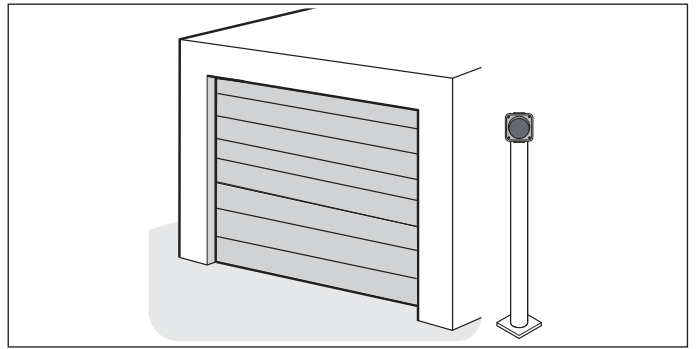

Fig. 7

7. After the door CLOSE end position has been reached, the traffic lights on both sides are switched off.

- ⇒ **Both sides:** Traffic lights off.

### 13.4 Performing obstacle detection

The operator stops and reverses slightly if it encounters an obstacle. This prevents injury and damage to property. The door will be partially or completely opened, depending on the setting. The partial reversal is pre-set at the factory.



#### INFORMATION

- In the automatic closing function, the door opens completely.
- If the photocell is interrupted, the door runs on for a longer distance.

The following safety devices are installed to detect obstacles:

- photocell (object protection)
- safety contact strips (personal protection)
- obstacle recognition of the operator (personal protection)

Here, also note Chapter “14. Maintenance and care”.

#### Obstacle recognition in door OPEN direction

- ⇒ If the door meets an obstacle, the door stops, reverses a short distance in door OPEN direction and stops.
- ⇒ Operator expects a new command and does not start automatically.
- ⇒ After receiving a command, the operator moves in the door CLOSE direction.

#### Obstacle recognition in door CLOSE direction with automatic closing function

- ⇒ If the door meets an obstacle, the door stops and reverses a short distance until it reaches the door OPEN end position.
- ⇒ The door closes automatically after the hold open time.

# 13. Operation



## INFORMATION

- If the door encounters an obstacle again in the door CLOSE direction, the operator stops and reverses completely to the door OPEN end position. The door stays there. The automatic closing function is interrupted. The hold open time and clearing time do not start again until a command for door CLOSE. The door is then automatically closed.

## STOP output

If the STOP safety input is open, the operator stops the door movement. No more commands are executed. The potential-free NC contact, for example, is suitable for connecting an EMERGENCY STOP.

⇒ Status LED on the control unit flashes.





## Resetting the STOP safety input

1. Reset safety input (close contact).
  - ⇒ Door opens up to door OPEN end position.
  - ⇒ Hold open time and clearing time run out.
  - ⇒ Door closes automatically.
2. Execute a command using the button.
  - ⇒ Door opens up to door OPEN end position.
  - ⇒ Hold open time and clearing time run out.
  - ⇒ Door closes automatically.

## 13.5 Power-saving mode

To save energy, the operator control unit switches to power-saving mode after the factory-specified period. The factory-set period before the control unit switches to power-saving mode after expiration of the set lighting time is 20 seconds. This value cannot be changed. Connected accessories are deactivated and then reactivated at the next command from a button or radio. Connected accessories may include: photocell, safety contact strip and external radio receiver.

Because external radio receivers are deactivated in power-saving mode, they cannot receive commands from the remote control and send them to the operator. Set DIP switch 3 to "ON" to power the entire system continuously. Power-saving mode is then deactivated.

DIP switches on the wall control unit	ON	OFF
		
<b>3</b> 	<ul style="list-style-type: none"> <li>• Continuous power to the complete system activated</li> </ul>	<ul style="list-style-type: none"> <li>• Power-saving mode activated</li> </ul>

If the operator is in power-saving mode, the green status LED blinks briefly in 3-second cycles.

## 13.6 In the event of a power failure

The programmed force values and end positions of the operator remain saved in the event of a power failure. After the mains voltage has been restored, the first movement of the operator after a pulse is always door OPEN.

Also follow the instructions for emergency release in Chapter "11.11 Installing and removing the battery pack" and "13.7 Function of the emergency release".

## 13.7 Function of the emergency release

In the event of a power failure, the door can be opened and closed manually from the inside using a mechanical emergency release.

In particular, observe the warnings below.

### WARNING



#### Danger for trapped persons!

Persons may be trapped inside the garage. If trapped persons cannot free themselves, severe injury or death may result.

- ▶ Check the function of the emergency release at monthly intervals, **particularly** from inside in the door CLOSE end position and if necessary, also from outside.
- ▶ You must have faults repaired professionally without delay.

### WARNING



#### Danger due to falling parts of doors!

If the emergency release is actuated, weak or broken springs may cause the door to close suddenly and unexpectedly. This may cause serious or fatal injury.

- ▶ The emergency release should be used only with the door closed.
- ▶ Use the emergency release with great caution if the door is open.
- ▶ Keep persons and animals clear of the range of movement of the door.

### NOTE

- The cord of the emergency release may only be used for unlocking or locking. The red cord must never be pulled in order to move the unlocked door.
- The emergency release is only suitable for opening or closing the door in an emergency. The emergency release is not suitable for regular opening or closing. This could cause damage to the operator and door. The emergency release must only be used in emergencies such as a power failure.
- During emergency release, the door could open or close by itself surprisingly quickly due to a broken spring or incorrect setting of the weight balancing. Damage to the door system could occur.
- After the operator is locked back in, move the door into the door OPEN end position. Otherwise the limit stop will be hit with too much force.
- Objects in the movement area of the door may be jammed and damaged. Objects must not be in the range of movement of the door.

## 13. Operation



### INFORMATION

- The function of the emergency release must be checked, **particularly** in the door CLOSE end position and if necessary, also from outside. Unlocking must be possible.
- It can be locked and released in any door position.
- The emergency release must be easy to operate in all necessary positions.

1. Disconnect the operator from the mains voltage.

Check it is disconnected from the power supply.

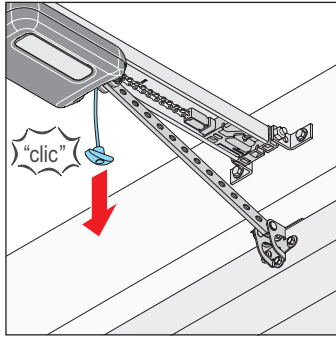
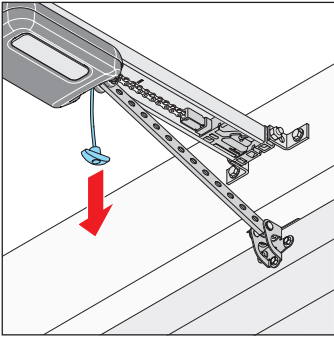

Fig. 2

Fig. 3

2. Pull once on the emergency release cord.
  - ⇒ **The motor carriage is released.**
  - ⇒ Door can be moved by hand.
3. Pull the emergency release cord once more.
  - ⇒ **The motor carriage is locked.**
  - ⇒ The door can only be moved by the operator.
4. Connect the operator to the mains voltage.

Check that the voltage supply is connected.
5. Give the operator a command.
  - ⇒ After a power failure, the first pulse of the operator is always in the door OPEN direction.
  - ⇒ The operator must drive completely to the door OPEN end position.

## 14. Maintenance and care

### 14.1 Important notes and information

Service the operator regularly as directed below. This ensures safe operation of your operator and a long service life. Observe the basic warnings listed below.

#### DANGER



##### **Danger if not observed!**

If warnings are not observed, serious injury or death may result.

- ▶ All warnings must be complied with.



##### **Danger due to electric current!**

Contact with live parts may result in electric current flowing through the body. Electric shock, burns or death may result.

- ▶ All work on electrical components must be carried out by a **trained electrician**.
- ▶ Disconnect the mains plug before working on the operator.
- ▶ If a battery pack is connected, disconnect it from the control unit.
- ▶ Check that the operator is not live.
- ▶ Secure the operator against being switched back on.

#### WARNING



##### **Danger of falling!**

Unsafe or defective ladders may tip and cause fatal or serious accidents.

- ▶ Use only a non-slip, stable ladder.
- ▶ Ensure that ladders are safely positioned.



##### **Danger for trapped persons!**

Persons may be trapped inside the garage. If trapped persons cannot free themselves, severe injury or death may result.

- ▶ Check the function of the emergency release at monthly intervals, **particularly** from inside in the door CLOSE end position and if necessary, also from outside.
- ▶ You must have faults repaired professionally without delay.



##### **Danger due to falling parts of doors!**

Parts of the door may become detached and fall. If persons or animals are hit, this may cause serious injury or death.

- ▶ Always keep the moving door in sight.
- ▶ Keep all persons and animals away from the door until it is completely opened or closed.



##### **Danger of crushing and shearing!**

If the door moves and there are persons or animals in the movement area, crushing and shearing injuries may be caused by the mechanism and safety edges of the door.

- ▶ Only use the operator when you have a direct view of the door.
- ▶ All danger zones must be visible during the entire door operation.
- ▶ Always keep the moving door in sight.
- ▶ Keep persons and animals clear of the range of movement of the door.
- ▶ Never put your hand near the door when it is moving or near moving parts. In particular, do not reach into the moving push arm.
- ▶ Do not reach into the ceiling suspension unit when the motor carriage is running along the rail.
- ▶ Do not drive through the door until it has opened completely.
- ▶ Never stand under the opened door.



##### **Danger due to hot surfaces!**

After frequent operation, parts of the motor carriage or the control unit may become hot. If the cover is removed and hot parts are touched, they may cause burns.

- ▶ Allow the operator to cool down before removing the cover.

#### NOTE

- The motor carriage is supplied with safety low voltage via the chain and the rail.  
The use of oil or grease will greatly reduce the conductivity of the chain, rail and motor carriage. This may result in faults due to inadequate electrical contact. The chain and rail are maintenance-free and must not be oiled or greased.
- The use of unsuitable cleaning agents may damage the surface of the operator.  
Clean the operator with a dry lint-free cloth only.



# 14. Maintenance and care

## 14.2 Maintenance schedule

How often?	What?	How?
Once a month	• Test the emergency release	• See Chapter “13.7 Function of the emergency release”
	• Test obstacle detection	• See Chapter “12.1 Testing obstacle detection”
	• Checking the photocell or light curtain	• Interrupt the active photocell/light curtain while the door is closing. The door must stop and open slightly. If automatic closing is activated, the door opens completely. • If necessary, clean the photocell/light curtain; see Chapter “14.3 Care”
	• Test obstacle recognition	• See Chapter “12.1 Testing obstacle detection”
Once a year	• Test the door and all moving parts	• As directed by the door manufacturer
	• Check screws on door, ceiling or lintel	• Check that screws are tight and tighten if necessary
As needed	• Chain and rail	• maintenance-free
	• Rail	• See Chapter “14.3 Care”
	• Clean the housing of the wall control unit and motor carriage	• See Chapter “14.3 Care”

## 14.3 Care

### Clean rail, motor carriage and wall control unit

1. Pull the mains plug out of the power outlet.  
If a battery pack has been installed, remove the wall control unit cover and disconnect the battery pack from the wall control unit. See also Chapter “11.11 Installing and removing the battery pack”. Then check that the power is disconnected.
2. Remove loose dirt with a moist, lint-free cloth:
  - from the motor carriage and the wall control unit
  - from the rail and the inside of the rail
3. If applicable, install the battery pack in reverse order of removal.

Connect the operator to the mains voltage.  
Check that the voltage supply is connected.

### Cleaning the photocell

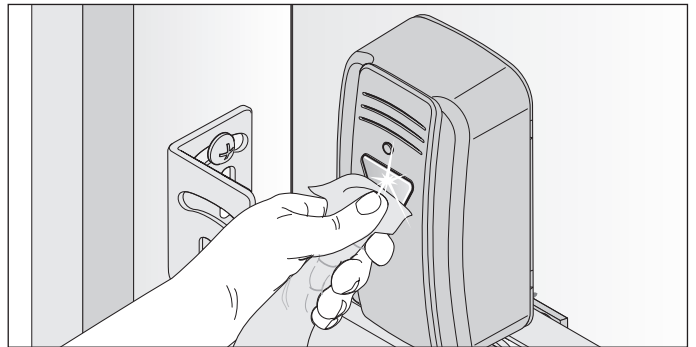

Fig. 1

**NOTE**

- Do not change the position of the photocell when cleaning it.

1. Clean the housing and reflectors of the photocell with a damp, lint-free cloth.

# 15. Troubleshooting

## 15.1 Important notes and information

Observe the basic warnings listed below.

### DANGER



#### **Danger if not observed!**

If warnings are not observed, serious injury or death may result.

- ▶ All warnings must be complied with.



#### **Danger due to electric current!**

Contact with live parts may result in electric current flowing through the body. Electric shock, burns, or death may result.

- ▶ All work on electrical components must be carried out by a **trained electrician**.
- ▶ Disconnect the mains plug before working on the operator.
- ▶ If a battery pack is connected, disconnect it from the control unit.
- ▶ Check that the operator is not live.
- ▶ Secure the operator against being switched back on.

### WARNING



#### **Danger of falling!**

Unsafe or defective ladders may tip and cause serious or fatal accidents.

- ▶ Use only a non-slip, stable ladder.
- ▶ Ensure that ladders are safely positioned.



#### **Danger for trapped persons!**

Persons may be trapped inside the garage. If trapped persons cannot free themselves, severe injury or death may result.

- ▶ Check the function of the emergency release at monthly intervals, **particularly** from inside in the door CLOSE end position and if necessary, also from outside.
- ▶ You must have faults repaired professionally without delay.



#### **Danger due to falling parts!**

Parts of the door may become detached and fall. Persons may be hit. Severe injuries or death may result.

- ▶ Always keep the moving door in sight.
- ▶ Keep all persons and animals away from the door until it is completely opened or closed.
- ▶ Do not drive through the door until it has opened completely.



#### **Danger of entrapment!**

Loose clothing or long hair may be trapped by moving parts of the door.

- ▶ Keep clear of the moving door.
- ▶ Always wear tight-fitting clothing.
- ▶ Wear a hairnet if you have long hair.



#### **Danger of crushing and shearing!**

If the door moves and there are persons or animals in the movement area, crushing and shearing injuries may be caused by the mechanism and safety edges of the door.

- ▶ Only use the operator when you have a direct view of the door.
- ▶ All danger zones must be visible during the entire door operation.
- ▶ Always keep the moving door in sight.
- ▶ Keep persons and animals clear of the range of movement of the door.
- ▶ Never put your hand near the door when it is moving or near moving parts. In particular, do not reach into the moving push arm.
- ▶ Do not reach into the ceiling suspension unit when the motor carriage is running along the rail.
- ▶ Do not drive through the door until it has opened completely.
- ▶ Never stand under the opened door.



#### **Danger due to optical radiation!**

Looking into an LED at short range for an extended period may cause optical glare. This may temporarily reduce vision. This may cause serious or fatal accidents.

- ▶ Never look directly into an LED.



#### **Danger due to hot surfaces!**

After frequent operation, parts of the motor carriage or the control unit may become hot. If the cover is removed and hot parts are touched, they may cause burns.

- ▶ Allow the operator to cool down before removing the cover.



### NOTE

- If the door is not in view and the radio remote control is actuated, objects in the movement area of the door may be jammed and damaged. Objects must not be in the range of movement of the door.



### INFORMATION

- The control unit detects a short-circuit between chain and rail and then switches the operator off.

# 15. Troubleshooting

---

## 15.2 Preparing for troubleshooting

The following guide to troubleshooting lists potential problems and their causes and information on correcting them. In some cases, other chapters and sections with a more detailed description are referenced. You will be prompted to call a **qualified specialist** if this is required.

Work on the electrical system and live parts must be performed by a **trained electrician**.

1. Disconnect the operator from the mains voltage.

If a battery pack has been installed, remove the control unit cover and disconnect the battery pack from the control unit; see Chapter “**7.2 Cover of the wall control unit**” and Chapter “**11.11 Installing and removing the battery pack**”.

Then check that the power is disconnected.

2. After working on the operator, if applicable replace the battery pack in reverse order.
3. Connect the operator to the mains voltage.  
Check that the voltage supply is connected.  
⇒ The operator is supplied with mains voltage again.

# 15. Troubleshooting





## 15.3 Time sequences of operator lighting in normal mode and in case of faults

The flash sequences show information on malfunctions for technicians, end customers and telephone support.

### In normal mode

Flash sequences	Possible cause	Corrective action
<b>Normal mode</b>  Operator lighting blinks as warning light	<ul style="list-style-type: none"> <li>• Programming mode activated</li> <li>• Pre-warning time activated</li> <li>• Function activated via HFL</li> <li>• Interruption of a safety device during the movement</li> </ul>	<ul style="list-style-type: none"> <li>• For information</li> <li>• Remove obstacle</li> </ul>

### In the event of faults

Flash sequences	Possible cause	Corrective action
<b>Requirement</b>  Operator expects a command	<ul style="list-style-type: none"> <li>• Waiting for a confirmation during the position programming run of door CLOSE position</li> </ul>	<ul style="list-style-type: none"> <li>• Confirmation of position programming run or</li> <li>• Sluggish point during programming; see Chapter “9.3 Carrying out manual initial operation”</li> </ul>
<b>Alarm</b>  A process has triggered a fault	<ul style="list-style-type: none"> <li>• Photocell/light curtain/safety device not OK before movement</li> <li>• Dead man movement, safety device not OK</li> <li>• Motor return from outside (e.g. due to attempted break-in)</li> </ul>	<ul style="list-style-type: none"> <li>• Check photocell/light curtain, realign if necessary</li> <li>• If necessary, have components replaced by a qualified specialist</li> <li>• Have it checked by a qualified specialist</li> <li>• For information</li> </ul>
<b>Service</b>  A process has triggered a fault	<ul style="list-style-type: none"> <li>• Service (service days, service cycles have been reached)</li> <li>• Motor temperature is too high (overheating)</li> <li>• Programming of difficult positions in case of reversing with no visible cause. The complete distance is traversed from end position to end position (dead man by radio, under direct view only)</li> </ul>	<ul style="list-style-type: none"> <li>• Have the service performed by a qualified specialist</li> <li>• Allow motor to cool</li> <li>• For information</li> </ul>
<b>Fault</b>  Operator or parts of the operator faulty	<ul style="list-style-type: none"> <li>• Self-test of electronics</li> <li>• Blockage detection (gear breakage, Hall sensor fault)</li> <li>• Limit stop does not operate (e.g. wire break, limit stop fault)</li> <li>• Counting pulses sent in the wrong direction (motor cable was incorrectly connected)</li> <li>• Run time exceeded</li> <li>• Error during plausibility test of Memo</li> <li>• Intrinsically safe wicket door contact defective</li> </ul>	<ul style="list-style-type: none"> <li>• Have it checked and, if necessary, components replaced by a qualified specialist</li> <li>• Have cable connections checked by a qualified specialist and, if necessary, have components replaced</li> <li>• Check wiring, correct if necessary</li> <li>• Movement range too long, movement range is restricted to max. 7,000 mm</li> <li>• Have it checked and, if necessary, components replaced by a qualified specialist</li> <li>• Carry out power reset of 20 seconds</li> <li>• If necessary, have component replaced</li> </ul>

# 15. Troubleshooting

## 15.4 Troubleshooting table

Problem	Possible cause	Test/check	Remedy
The operator opens the door when the transmitter or command device is actuated but does not close it.	• Photocell/light curtain and safety device interrupted	• Check photocell/light curtain and safety devices	• Remove obstacle • The photocell/light curtain must be aligned • If necessary, have it checked and replaced by a qualified specialist
	• Automatic closing function activated	• Wait to see whether the operator starts automatically after 30 seconds	• Automatic closing function deactivated • Have the cause corrected by a trained electrician
Operator cannot be operated with the command device.	• No power	• Check voltage supply	• Check the power outlet with a different device, for example by plugging in a lamp
	• Limit stop on motor carriage defective	• Unlock operator and push motor carriage to the centre of the rail • Lock operator • Actuate transmitter • If the operator still closes the door but does not open it, the limit stop is defective	• Have the limit stop replaced by a qualified specialist
	• The operator was unlocked by the emergency release mechanism	• Check that the door can be moved manually	• Pull the emergency release handle to activate the operator, see Chapter “ <b>13.7 Function of the emergency release</b> ”
	• Command device incorrectly connected to the operator	• Check function of operator with a transmitter	• Check wiring, correct if necessary
	• Transmitter defective	• Operator cannot be started with the transmitter	• Check transmitter voltage supply • If necessary, replace the battery of the transmitter • If necessary, replace the transmitter with a new one
	• Operator defective	• Operator cannot be started with the transmitter or the connected command device	• Have operator repaired or replaced by a qualified specialist
	• Electrical supply voltage outside the approved range	• Have the mains voltage checked by a <b>trained electrician</b>	• Have the cause corrected by a trained electrician
	• STOP safety input, e.g. EMERGENCY STOP, triggered	• Status LED is off, the status LED blinks	• Reset STOP safety input, see Chapter “ <b>11.10 STOP connection</b> ”
When a button on the transmitter is pressed, the operator does not open or close the door.	• Transmitter not programmed	• Radio LED does not light up when the transmitter is operated	• Programme transmitter
	• Battery in the transmitter is flat		• Replace the battery of the transmitter
	• Transmitter defective	• LED on transmitter does not light up	• Replace transmitter
Radio command cannot be programmed	• Memory full	• All four LEDs for radio blink cyclically for about 3 seconds	• Memory full, see Chapter “ <b>10.5 Programming the transmitter</b> ”
MEMO Identifier error	• Incorrect MEMO	• All four LEDs for radio blink briefly cyclically. The operator lighting of the motor carriage blinks 4 times short and 4 times long.	• Disconnect operator from the voltage supply, unplug Memo, re-supply operator with power

## 15. Troubleshooting

Problem	Possible cause	Test/check	Remedy
MEMO device type error	<ul style="list-style-type: none"> <li>• System error</li> </ul>	<ul style="list-style-type: none"> <li>• All four LEDs blink cyclically for a long time and then go out for a short time. If voltage is present, the operator lighting of the motor carriage blinks an additional four times.</li> </ul>	<ul style="list-style-type: none"> <li>• Memo can be deleted via the Radio button; see Chapter <b>“10.11 Deleting all radio channels in the receiver”</b></li> </ul>
Operator stops the door during closing and opens it partially or completely	<ul style="list-style-type: none"> <li>• Door has detected an obstacle</li> </ul>	<ul style="list-style-type: none"> <li>• Check whether there are any obstacles in the movement range of the door</li> </ul>	<ul style="list-style-type: none"> <li>• Remove obstacle</li> <li>• If necessary, have door mechanism checked and set by a qualified specialist</li> </ul>
	<ul style="list-style-type: none"> <li>• Photocell/light curtain was interrupted</li> </ul>	<ul style="list-style-type: none"> <li>• Check LEDs on photocell/light curtain</li> </ul>	<ul style="list-style-type: none"> <li>• Remove obstacle</li> </ul>
	<ul style="list-style-type: none"> <li>• Photocell/light curtain defective or misaligned</li> </ul>		<ul style="list-style-type: none"> <li>• Align photocell/light curtain</li> <li>• Check wiring</li> <li>• If necessary, have the photocell replaced by a qualified specialist</li> </ul>
Operator stops the door during the opening process and moves a short distance in door CLOSE direction	<ul style="list-style-type: none"> <li>• Door has detected an obstacle, photocell or safety device has been interrupted</li> </ul>	<ul style="list-style-type: none"> <li>• Check whether there are any obstacles in the movement range of the door</li> <li>• Check the weight balance of the door – it must run smoothly</li> <li>• Check photocell and safety devices</li> </ul>	<ul style="list-style-type: none"> <li>• Remove obstacle</li> <li>• If necessary, have door mechanism checked and repaired by a qualified specialist</li> <li>• The photocell must be aligned; if necessary, have it checked and replaced by a qualified specialist</li> </ul>
Operator lighting does not work	<ul style="list-style-type: none"> <li>• Operator lighting defective</li> </ul>		<ul style="list-style-type: none"> <li>• Have motor carriage replaced with a new one by a qualified specialist</li> </ul>
Speed varies while opening and closing the door	<ul style="list-style-type: none"> <li>• Rail dirty</li> </ul>		<ul style="list-style-type: none"> <li>• Clean with a moist, lint-free cloth; see Chapter <b>“14.3 Care”</b></li> </ul>
	<ul style="list-style-type: none"> <li>• Chain tightened incorrectly</li> </ul>		<ul style="list-style-type: none"> <li>• Tighten the chain; see Chapter <b>“6.4 Installing installation variant A or B of the operator system”</b> or <b>“6.5 Installing installation variant C of the operator system”</b></li> </ul>
	<ul style="list-style-type: none"> <li>• Weight balance of the door has changed</li> </ul>	<ul style="list-style-type: none"> <li>• Move the operator to the door CLOSE position and check the weight balance of the door</li> </ul>	<ul style="list-style-type: none"> <li>• If necessary, have it checked, adjusted or have components replaced by a qualified specialist</li> </ul>
Motor carriage is pulled away from limit stop	<ul style="list-style-type: none"> <li>• Spring tension is too high, door is opened too far</li> </ul>	<ul style="list-style-type: none"> <li>• Check door operation and spring tension</li> <li>• Check door OPEN end position</li> </ul>	<ul style="list-style-type: none"> <li>• Adjust door operation and spring tension</li> <li>• Adjust door OPEN end position</li> <li>• Fit Lock accessory</li> </ul>

# 15. Troubleshooting

---

## 15.5 Replacing the motor carriage

The instructions for “**Disassembling the motor carriage**” can be downloaded from **SOMMER** at: **www.sommer.eu**

If applicable, save the existing settings on the old motor carriage via SOMlink and a WiFi-enabled device. The settings can be transferred to the new motor carriage later.

The new motor carriage is in delivery condition from the factory. Before replacing the motor carriage, make sure that used accessories have been transferred to the new motor carriage.

Initial operation must be repeated and the special functions of the motor carriage reset, see Chapter “**9. Initial operation**” and “**10. Connections and special functions of the motor carriage**”.

Handheld transmitters which are used must also be reprogrammed, see Chapter “**10.5 Programming the transmitter**”.

On the other hand, handheld transmitters do not have to be programmed if the Memo tiga accessory part has already been used.

After successful initial operation, run a function test and a final test; see Chapter “**12. Function test/final test**”.



### INFORMATION



- Save the existing settings of the motor carriage with the help of SOMlink and a WiFi-enabled device. After the new motor carriage has been inserted, reinstall the data.

## 16. Taking out of operation, storage and disposal

### 16.1 Important notes and information

Disassembly of the operator may only be performed by a **qualified specialist**. In particular, observe the warnings below.

#### **DANGER**



##### **Danger if not observed!**

If warnings are not observed, serious injury or death may result.

- ▶ All warnings must be complied with.



##### **Danger due to electric current!**

Contact with live parts may result in electric current flowing through the body. Electric shock, burns or death will result.

- ▶ All disassembly work on electrical components must be carried out by a **trained electrician**.
- ▶ Disconnect the mains plug before disassembling the operator.
- ▶ If a battery pack is connected, disconnect it from the control unit.
- ▶ Check that the operator is not live.
- ▶ Secure the operator against being switched back on.

#### **WARNING**



##### **Danger of falling!**

Unsafe or defective ladders may tip and cause serious or fatal accidents.

- ▶ Use only a non-slip, stable ladder.
- ▶ Ensure that ladders are safely positioned



##### **Danger of tripping and falling!**

Unsafely positioned parts such as packaging, operator parts or tools may cause trips or falls.

- ▶ Keep the disassembly area free of unnecessary items.
- ▶ Place all parts where no-one is likely to trip or fall over them.
- ▶ The general workplace guidelines must be observed.



##### **Danger due to hot surfaces!**

After frequent operation, parts of the motor carriage or the control unit may become hot. If the cover is removed and hot parts are touched, they may cause burns.

- ▶ Allow the operator to cool down before removing the cover.



##### **Danger due to optical radiation!**

Looking into an LED at short range for an extended period may cause optical glare. This may temporarily reduce vision. This may cause serious or fatal accidents.

- ▶ Never look directly into an LED.



##### **Risk of eye injury!**

Chips flying when drilling may cause serious injuries to eyes and hands.

- ▶ Wear safety glasses when drilling.



##### **Risk of injury in the head region!**

Impact with suspended objects may cause serious abrasions and cuts.

- ▶ You must wear a safety helmet when disassembling suspended parts.



#### **CAUTION**



##### **Risk of injury to hands!**

Rough metal parts may cause abrasions and cuts when picked up or touched.

- ▶ You must wear your personal safety gloves when working with rough metal parts.



#### **NOTE**

- If there is a battery pack in the control unit, it must be removed by a **trained electrician**. See Chapter “11.11 Installing and removing the battery pack”.

### 16.2 Taking out of operation and disassembly

The operator and its accessories must be disconnected from the power supply when taking them out of operation or during disassembly.

1. Disconnect the operator from the mains voltage.  
If a battery pack has been installed, remove the control unit cover and disconnect the battery pack from the control unit; see also Chapter “11.11 Installing and removing the battery pack”. Then check that the equipment is disconnected from the power supply and secure it against being switched on again.
2. Disassembly is carried out in reverse order of installation.

### 16.3 Storage

Store the packaging units as follows:

- in enclosed, dry rooms so that they are protected from moisture
- at a storage temperature from  $-25\text{ °C}$  to  $+65\text{ °C}$
- secure to prevent falling
- leave room for unhindered passage

#### **NOTE**

- Improper storage may damage the operator. The operator must be stored in closed and dry rooms.



## 16. Taking out of operation, storage and disposal

### 16.4 Disposal of waste

Observe the instructions for disposal of packaging, components, batteries and, if applicable, the battery pack.

#### **WARNING**



##### **Danger of hazardous substances!**

Improper storage, use or disposal of battery packs, batteries and operator components pose a risk to the health of humans and animals. Serious injury or death may result.

- ▶ Battery packs and batteries must be stored out of the reach of children and animals.
- ▶ Keep battery packs and batteries away from chemical, mechanical and thermal influences.
- ▶ Do not recharge old accumulators and batteries.
- ▶ Components of the operator as well as old accumulators and batteries must not be disposed of with household waste. They must be disposed of properly.



#### **NOTE**

- Dispose of all components in accordance with local and national regulations to avoid environmental damage.



#### **INFORMATION**

- Operator components that have been taken out of service as well as old accumulators and batteries must not be disposed of with household waste. Dispose of components which are no longer in use, old accumulators and batteries properly. You must observe the local and national regulations here.

## 17. Brief instructions for installation

The brief instructions describe the installation of **variants A and B**. The brief instructions do not replace the installation and operating manual. Read this Installation and Operating Manual carefully and, most importantly, observe all safety instructions and warnings.

This will ensure that you can install the product safely and optimally.

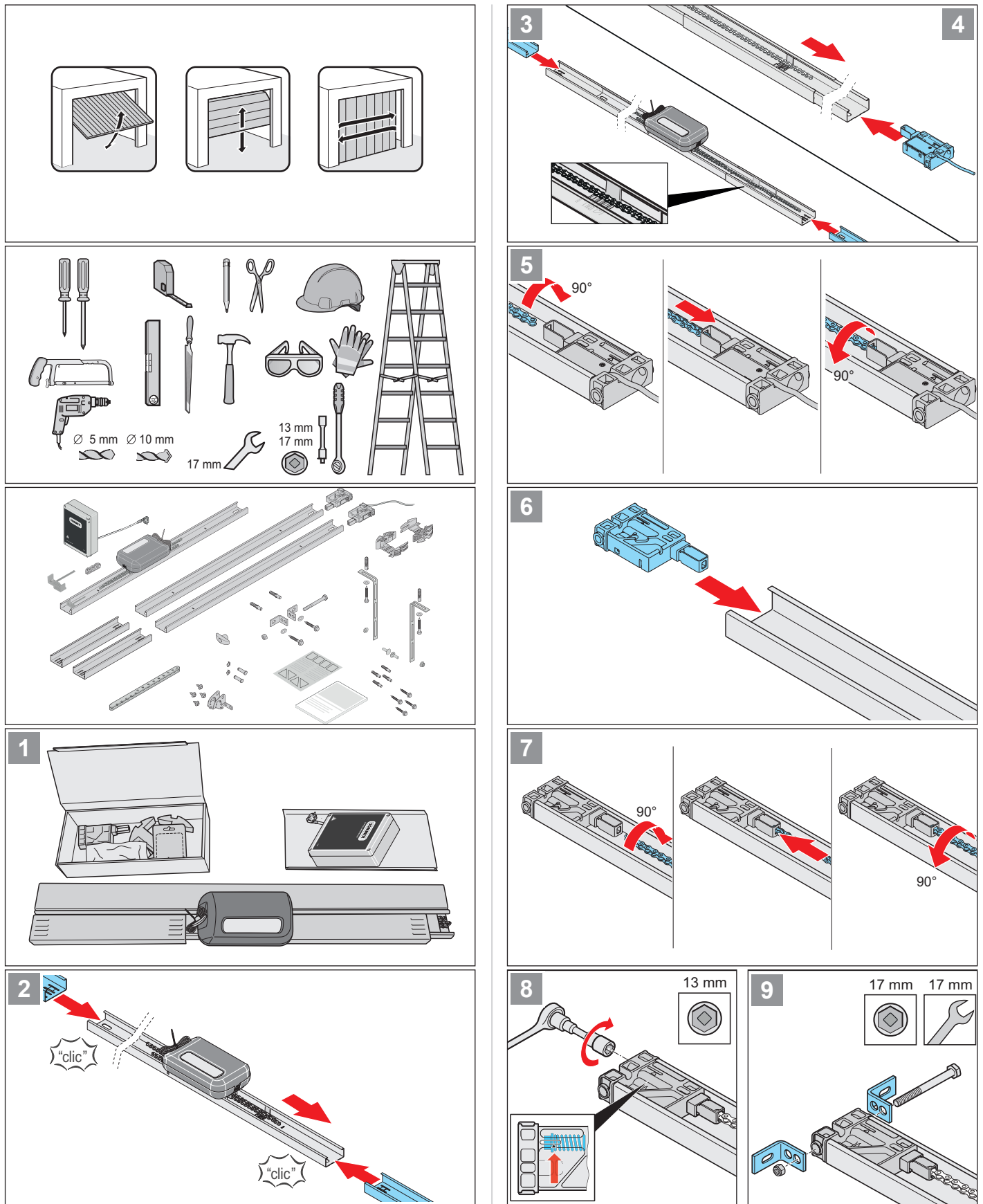

# 17. Brief instructions for installation

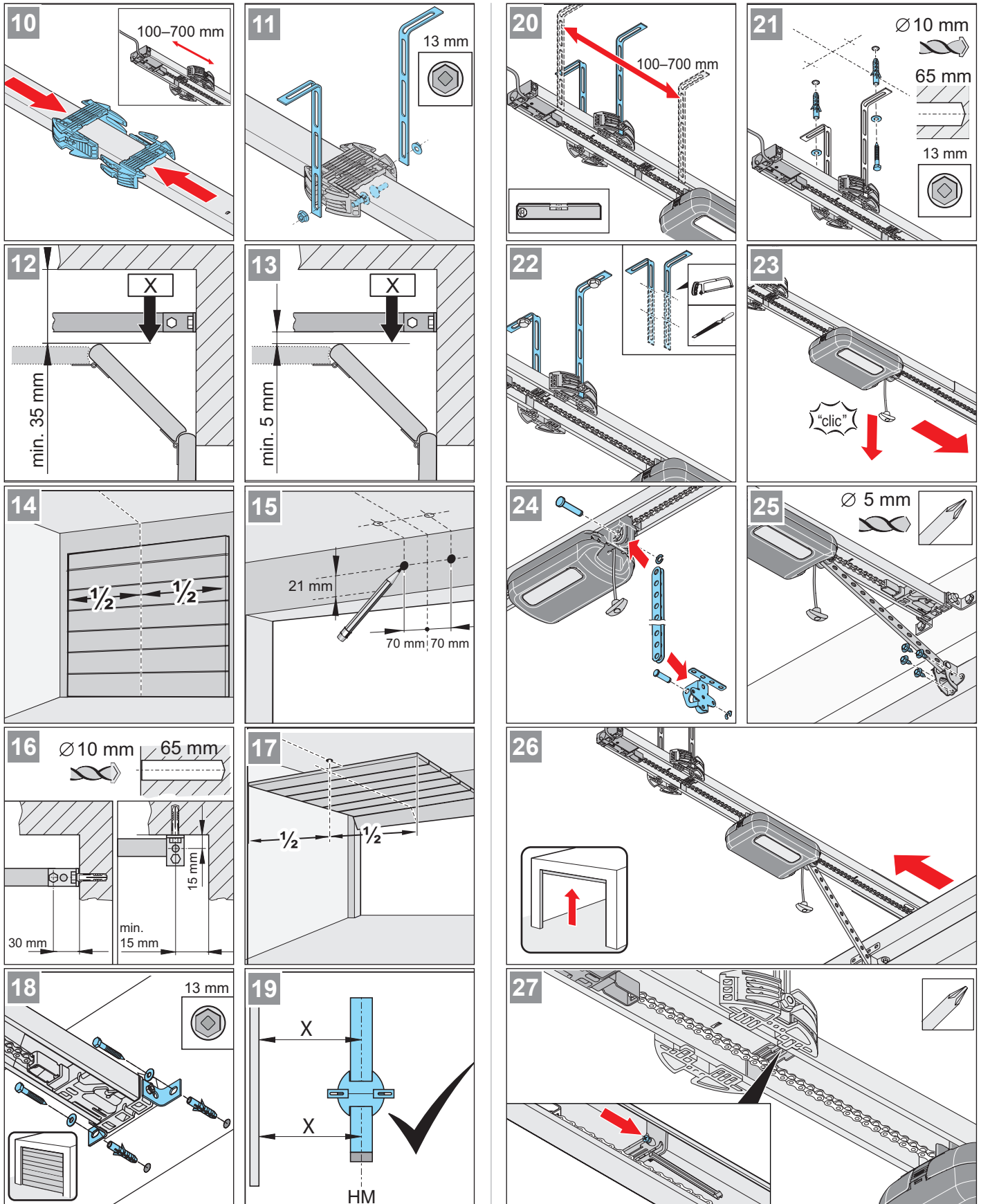

# 17. Brief instructions for installation

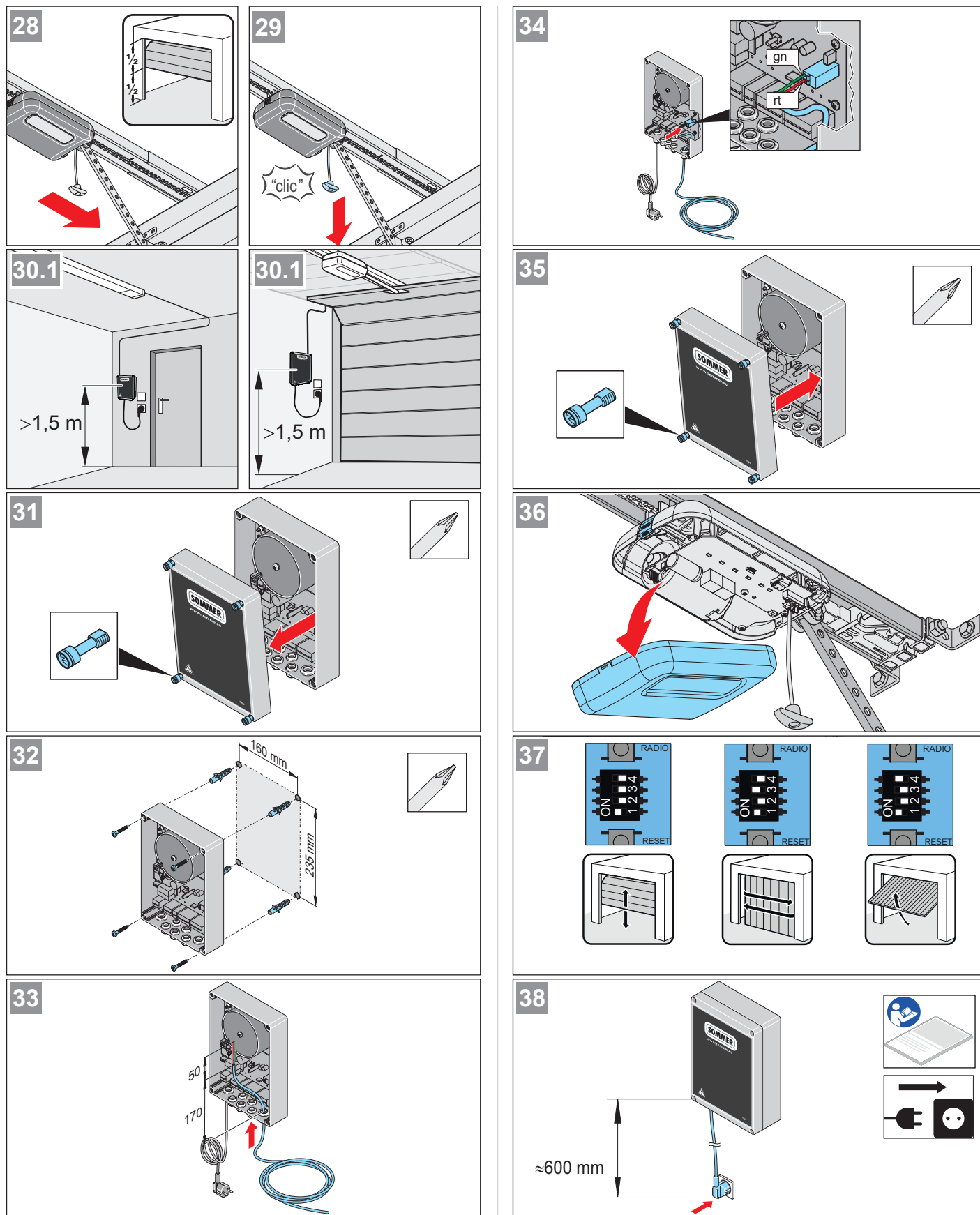

# 17. Brief instructions for installation

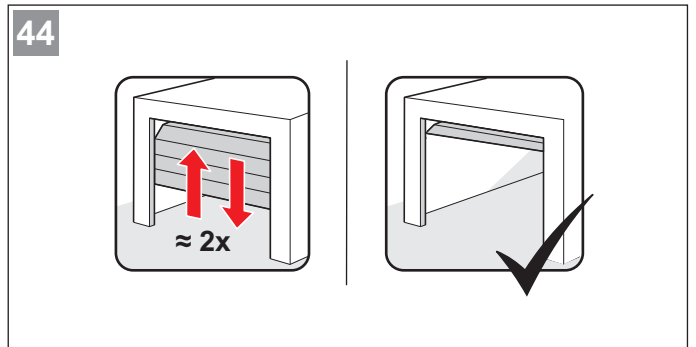
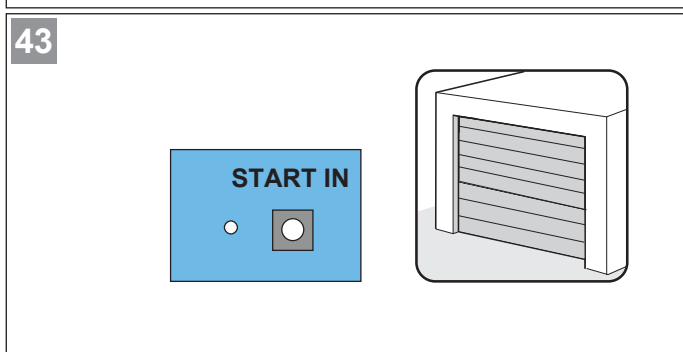
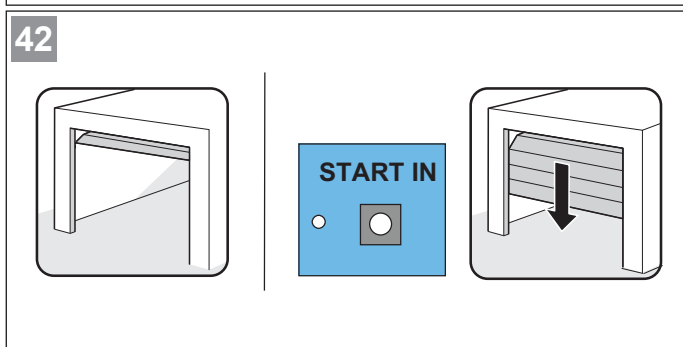
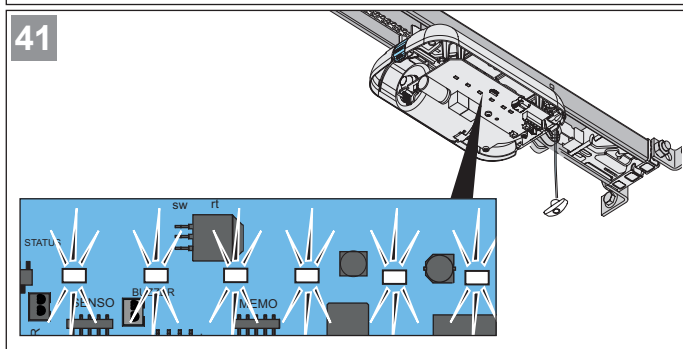
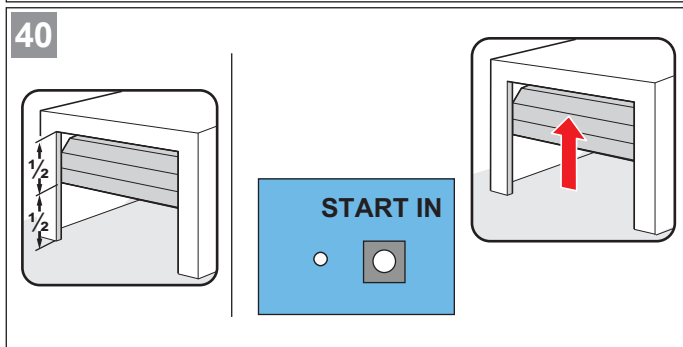
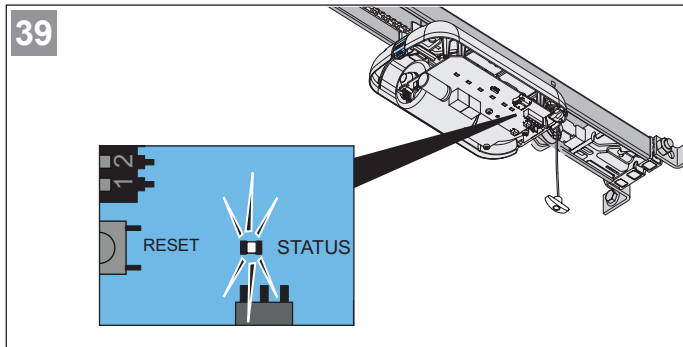



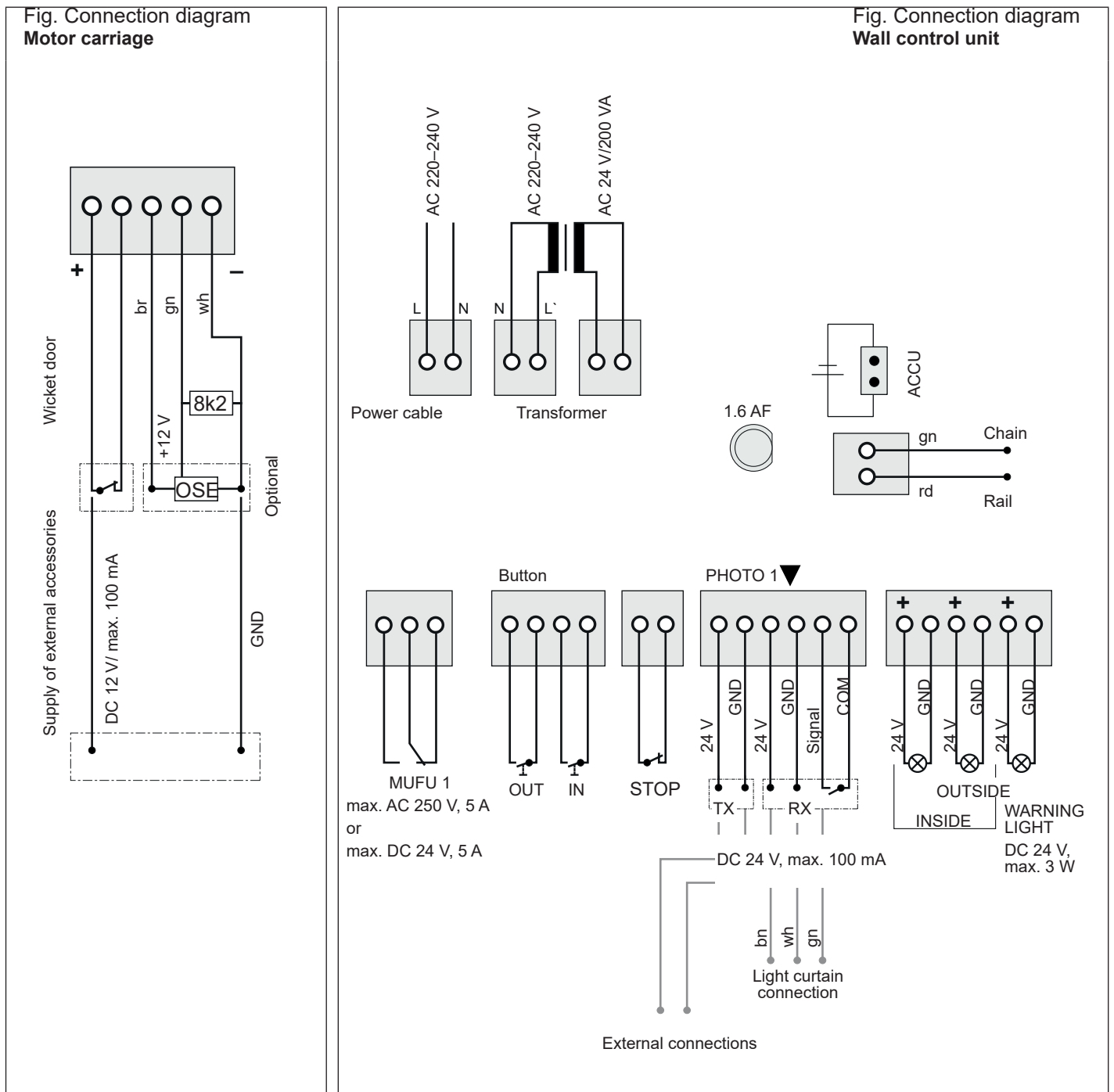

# 18. Connection diagrams and functions of the DIP switches for tiga



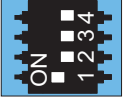
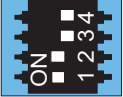
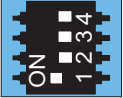
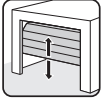
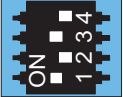

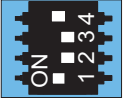
When connecting external devices, power-saving mode must be deactivated to ensure the voltage supply.

# 18. Connection diagrams and functions of the DIP switches for tiga

		ON	OFF
1		• Automatic closing function activated*	• Automatic closing function deactivated
2		• Partial opening activated	• Partial opening deactivated*
3+4		• No function	 *
3			
4			

 \* Factory setting

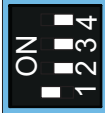
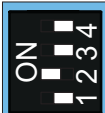
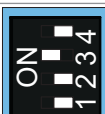
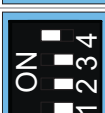
		ON	OFF 
1		• The red traffic light is <b>on</b> when the door is closed	• The red traffic light is <b>off</b> when the door is closed
2		• No function	• No function
3		• Continuous power to the complete system activated	• Power-saving mode activated
4		• No function	• No function

**SOMMER Antriebs- und Funktechnik GmbH**

Hans-Böckler-Straße 27  
73230 Kirchheim/Teck  
Germany

 +49 (0) 7021 8001-0

 +49 (0) 7021 8001-100

[info@sommer.eu](mailto:info@sommer.eu)  
[www.sommer.eu](http://www.sommer.eu)

© Copyright 2021 All rights reserved.