



TD-40E

CRAWLER DOZER



■ **Net Horsepower**
415 kW (555 hp)

■ **Blade Capacity**
up to 39.8 m³ (52 yd³)

■ **Operating Weight**
67700 kg (149,251 lb)

Comfortable, sealed
and sound suppressed cab equipped with:

- air recirculation system
- air conditioner/heater
- deluxe air suspension seat swivels 14 degrees right
- ergonomically designed joysticks
for superb motion and blade control

A system of preset travel
speed selection and automatic
downshift function provides
high productivity

Modular power train,
easily accessible diagnostic
check ports, filters and sight
gauges for increased serviceability

Arctic and hot climate, hot slag and coal handling dozer applications,
are designed for increased crawler dozer versatility

Exclusive suspension design
while giving the operator

TD-40E Extra - designed



415 kW (555 hp) Cummins QSK19 engine
meets EU Stage IIIA and EPA Tier 3
emission standards

Multi-unit modular cooling system
with hydraulically driven, 2-speed fan
improves cooling efficiency

Exclusive two-speed geared steering system
offers superior traction, steering control,
and 6 speeds fwd and rev

Louvered, two-piece and hinged
radiator guard doors

Sloped and tapered engine
hood provides excellent
visibility to the blade equipment

Design provides maximum durability
for a smoother, stable ride

Large capacity blades with full width wear liner
and double tilt/pitch system,
for all types of dozing operations

to deliver optimum performance

Optimum perform

- Wide track gauge for good side slope stability and increased cooling air flow area
- Superior steering performance with 2-speed geared steering system
- Advanced electro-hydraulic motion control system
- More direct blade lift force with front located lift cylinders
- Large capacity blades to push large loads
- Front and rear lights for improved night-time operation



Modular Power Train

Modular Power Train enables easy and efficient removal and replacement of major components: engine, torque converter, powershift transmission, steering drive and final drives with minimum downtime without disturbing other components.



Exclusive Undercarriage

- Simple, rugged, interlocking track guides
- Resilient equalizer bar end cushioned rebound brackets
- Standard sprocket rock guards and dirt deflector
- Simple, single tooth Split Master Link

ance



Large blades

Large blades with full width wear liner, have been designed for increased capacity, and abrasion resistant cutting edge and end bits are used for prolonged durability. Blades may be equipped with hydraulic blade tilt or tilt/pitch to increase the versatility of the dozer.



The Tier 3 approved Cummins QSK19 engine with state-of-the-art electronic controls and modular common-rail fuel system ensures clean, efficient performance, minimum maintenance and superior uptime.

Multi-unit modular cooling package with hydraulically driven, 2-speed fan improves cooling efficiency.



Advanced Motion Control



The speed ranges, machine direction changes and steering modes are controlled by the left hand joystick.

Buttons control transmission gear selection, while rocker switches select high and/or low steering ranges.



Shift preset function reduces gear shifting frequency and auto-downshift function provides high productivity w/o manual downshifting.



Specification

ENGINE

* Make and Model	CUMMINS QSK19
Type	In-line, 6-cylinder
Aspiration	Turbocharged and CAC
Fuel system	HPCR Electronic
Gross Power, SAE J1995	418 kW (560 hp)
** Net Power, SAE J1349	415 kW (555 hp)
Rated speed	2000 rpm
Max. torque @ 1500 rpm	2379 Nm (1,755 lb.ft)
Displacement	19 l (1,150 in ³)
Bore x Stroke	159 x 159 mm (6.25" x 6.25")
Lubrication, full flow filtering	full pressure
Air cleaner	dry type with exhaust aspirated primary and safety elements and service indicator

* Meets EU Stage IIIA and EPA Tier 3 emission regulations

** Net Power is the power available at the flywheel when the engine is equipped with air cleaner, muffler, alternator and fan at the minimum speed

TRANSMISSION & TORQUE CONVERTER

Modular, countershaft type power shift, electro-hydraulic control. Preset travel speed selection and auto-downshift.

Single stage 432 mm (17") torque converter with a 2.3:1 stall ratio drives to transmission through a double universal joint.

TRAVEL SPEEDS

Gear	Range	Forward		Reverse	
		km/h	(mph)	km/h	(mph)
1 st	Low	3.2	(2.0)	4.1	(2.5)
	High	4.1	(2.5)	5.2	(3.2)
2 nd	Low	5.2	(3.2)	6.5	(4.0)
	High	6.7	(4.2)	8.4	(5.2)
3 rd	Low	9.4	(5.8)	11.7	(7.3)
	High	12.0	(7.5)	14.9	(9.3)

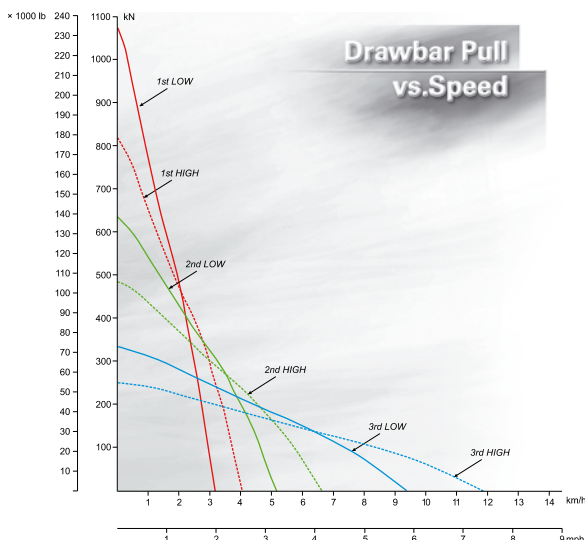

STEERING & BRAKING

Two speed geared steering module provides gradual turns while maintaining full power to both tracks plus conventional clutch-brake performance for tight or pivot turns. This type of steering system offers superior traction in all types of operations and terrain.

Coupled to 3-speed transmission, the 2-speed steering provides 6 speeds forward and 6 reverse. The left hand joystick controls transmission and steering drive for up and down shifting, steering, Hi/Lo selection and LH/RH gradual geared turn.

Foot pedal applies both brakes for parking and downhill control. Brakes are spring applied and hydraulically released.

FINAL DRIVES

Double-reduction modular type, with splash, lubricated pinion and bullgear initial stage and outboard planetary type final stage. Fully machined bolt-on ring-type sprocket rim is replaceable without removing the track frame.

TRACK FRAME

All-welded box section type track frames oscillate on pivot shafts mounted forward and isolated from final drives. A special forward track guiding system joins each of the two track frames to the tractor chassis.

The helical spring front idler recoil system absorbs shocks and limits track tension. Drum type front idlers have steel backed bronze bushings.

Track rollers, each side	7
Top idlers, each side	2
All rollers and idlers	lifespan lubricated
Oscillation at center of front idler	392 mm (15.4")

TRACKS

Lubricated Track System (LTS) virtually eliminates internal pin and bushing wear through use of a patented seal assembly. The split master link reduces chain removal and installation time.

Track shoe width, standard	610 mm (24")
Strutted track link pitch	280 mm (11")
Track shoes, each side	39
Ground contact area with std. shoes	4.4 m ² (6816 in ²)
Ground pressure	151 kPa (21.9 psi)
Height of grouser	93 mm (3.66")
Track adjustment	full hydraulic
Ground clearance	600 mm (23.7")
Fixed drawbar-approx. height from ground to centerline of 4.33" (110 mm) clevis	782 mm (30.8")

REFILL CAPACITIES

	Liter	(US gal)
Fuel tank	1362	(360)
Cooling system	74	(19.6)
Crankcase w/filters	68.8	(18.2)
Transmission system	270	(71)
Final drive, each side	85	(22.5)
Hydraulic reservoir	169	(45)

OPERATING WEIGHT

Includes standard equipment, Semi-U dozer w/tilt, single-shank ripper, coolant, lubricants, and full fuel tank..... 67700 kg (149,251 lb)

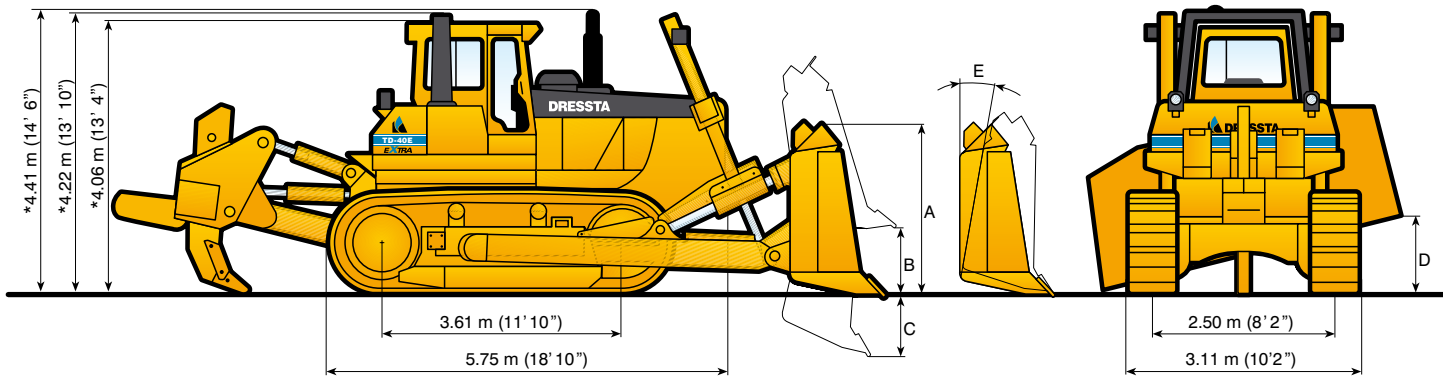

*VERTICAL DIMENSIONS INCLUDE 93 mm (3.66") GROUSER HEIGHT

OVERALL DIMENSIONS WITH EQUIPMENT

BLADE SELECTION	SEMI-U	FULL-U	COAL Blade
Length, with blade and drawbar	7.93 m (26')	8.24 m (27')	8.57 m (28' 1")
Length with blade and single shank ripper	10.35 m (34')	10.66 m (35')	11.0 m (36' 1")
Length with blade and multi-shank ripper	9.76 m (32')	10.12 m (33' 2")	10.4 m (34' 1")
Width over trunnions	3.73 m (12' 3")	3.73 m (12' 3")	3.73 m (12' 3")
Length with ripper only	Single Shank 8.51 m (27' 11")	Multi Shank 7.95 m (26')	–

BLADE SPECIFICATIONS

BLADE SELECTION	SEMI-U	FULL-U	COAL Blade
Blade capacity, SAE J1265	18.6 m ³ (24.3 yd ³)	22.8 m ³ (29.8 yd ³)	39.8 m ³ (52 yd ³)
Blade dimensions:			
– width over end bits	4.81 m (15' 9")	5.18 m (17')	6.85 m (22' 6")
– height, struts centered	A 2.23 m (7' 4")	2.26 m (7' 5")	2.50 m (8' 2")
Max. lift	B 1.53 m (60.2")	1.53 m (60.2")	1.46 m (57.5")
Max. drop below ground level	C 830 mm (32.7")	830 mm (32.7")	875 mm (34.4")
Max. tilt adjustment	D 1150 mm (45.3")	1250 mm (49.2")	1650 mm (65")
Max. pitch adjustment	E 10°	10°	10°
Weight of blade with full width wear liner package	6770 kg (14,925 lb)	7458 kg (16,442 lb)	7820 kg (17,240 lb)

RIPPER SPECIFICATIONS

RIPPER SELECTION	MULTI-SHANK	SINGLE SHANK	
		Standard	Deep
Tool Beam			
Overall width	2880 mm (113.5")	1670 mm (65.7")	1670 mm (65.7")
Cross section (width x height)	550x450 mm (21.7"x17.7")	610x510 mm (24"x20")	610x510 mm (24"x20")
Ground clearance under tool beam:			
– ripper raised	2090 mm (82.3")	1950 mm (76.8")	1950 mm (76.8")
– ripper lowered	350 mm (13.8")	250 mm (9.8")	250 mm (9.8")
Shank			
Number of shanks per ripper, max	3	1	1
Spacing center-to-center	1190 mm (47")	–	–
Penetration max.	1000 mm (39")	1290 mm (51")	1670 mm (66")
Ground clearance, max. raised	950 mm (37")	1000 mm (39")	720 mm (28")
Shank positions (vertical)	2	4	4
Weight			
Complete, including one shank	7588 kg (16,729 lb)	8356 kg (18,422 lb)	8461 kg (18,653 lb)
Each additional shank	570 kg (1,260 lb)	–	–
Penetration force	205 kN (46,084 lb)	200 kN (44,960 lb)	200 kN (44,960 lb)
Pryout force	622.5 kN (139,938 lb)	612 kN (137,578 lb)	612 kN (137,578 lb)

TD-40E

CRAWLER DOZER



HYDRAULIC CONTROL SYSTEM

Double gear pump, driven from torque converter.

Output @ 2368 rpm and 17.0 MPa (2,400 psi):

1st pump 288 l/min (76 gpm)
2nd pump 110 l/min (29 gpm)

Relief valve setting:

blade lift & ripper 17.0 MPa (2,400 psi)
tilt 18.4 MPa (2,670 psi)

Cylinders, bore and stroke:

blade lift 152.4 x 1760 mm (6" x 69.3")
tilt 254 x 175 mm (10" x 6.9")
tilt/pitch 220/254 x 175 mm (8.6"/10" x 6.9")

STANDARD EQUIPMENT

- Air cleaner, dry type with exhaust aspirated primary, safety elements and service indicator
- Air conditioner/heater/pressurizer/defroster; A/C condenser, behind roof mounted
- Alarm, back-up
- Alternator, 80 A
- Antifreeze, -37°C (-34°F)
- Batteries (4) 12V, 1920 CCA, maintenance free, cold start
- Brakes, foot, spring applied, hydraulically released
- Cab with 2 post ROPS, sound suppression, air recirculation system, 2 F & 2 R lights, 4 wipers w/washers, dome light, inside mirror (approved according to ROPS – SAE J1040 and FOPS – SAE J231)
- Coolant filter conditioner
- Cooling module; includes radiator, transmission oil cooler, hydraulic oil/fan drive oil cooler, charge air cooler; isolation mounted
- Cylinders, lift, with quick drop valve
- Decelerator – right foot pedal and brake – center foot pedal
- Diagnostic centers for power train and equipment hydraulic pressures
- Drawbar, fixed counterweight, 2900 kg (6400 lbs)
- Ecological drains for engine oil, radiator coolant and hydraulic oil
- Engine hood, sloped, partially perforated
- Engine side doors, partially perforated
- Exhaust, resonator with elbow
- Fan, hydraulically driven, suction type, 2-speed
- Filters, engine oil, full flow and by-pass with replaceable, „spin-on“ elements
- Filters, power train, equipment hydraulics, „spin-on“ micro glass type
- Final drive seal guard
- Fuel strainer
- Guards: crankcase (hinged) with front pull hook, transmission, fan, radiator and sprocket rock and dirt deflector
- Horn, electric
- Hydraulic control, 1 valve, 1 lever with pilot operated blade control (lift)
- Instruments:
 - Gauges: fuel level, engine coolant temperature, engine oil pressure, transmission oil temperature, voltmeter, hourmeter, joystick control display
 - Warning lights: air cleaner filter, transmission oil filter, hydraulic oil filter, transmission/clutch oil low pressure, ECM – engine diagnostic
- Audible & visual warning system: low engine coolant level, low engine oil pressure
- Lights w/guards, 2 F – lift cylinders mounted, 2 R – fuel tank mounted
- Muffler, under engine hood, insulated
- Radiator guard doors, louvered, two-piece, hinged
- Rear operator platform
- Receptacle, charging
- Seat belt (SAE J386) – 3" wide, retractable
- Seat, deluxe, air suspension type, fabric cover, adjustable with arm rests, swivel 14° to right
- Starting, 24 V.
- Steering, planetary type, 2-speed, left hand single lever control (joystick)
- Tools compartment
- Torque converter, single stage
- Track adjusters, hydraulic
- Track chain guides, integral
- Track chains, sealed and lubricated (LTS) with split master link, 39 links
- Track frame, 7 roller, 2500 mm (98") gauge, oscillating type, lifespan lubricated rollers and idlers
- Track shoes, 610 mm (24") severe service, grouser type
- Transmission, powershift, 3 speeds forward, 3 reverse, combined with 2 speed steering provides 6 speeds forward and 6 reverse; preset travel speed selection and auto-downshift
- Water separator, fuel system

OPTIONAL ATTACHMENTS

- Air recirculation system with MSHA filters
- AM/FM CD radio
- Blade Equipment:
 - Semi-U with tilt or tilt/pitch, 18.6 cu.m (24.3 cu.yd), full width wear liner package
 - Full-U with tilt or tilt/pitch, 22.8 cu.m (29.8 cu.yd), full width wear liner package
 - Coal blade with tilt or tilt/pitch, 39.8 cu.m (52 cu.yd)
- Canopy ROPS/FOPS (SAE J1040, J231)
- Counterweight 3945 kg (8,690 lbs), additional rear (4 plates)
- Fast fill system: fuel tank, engine crankcase, power train oil reservoir, hydraulic oil reservoir
- Guards:
 - Crankcase, severe service
 - Final drive, rock
 - Track roller
 - Transmission, severe service
- Heater/pressurizer/defroster
- Hydraulic controls, 3-spool valve, 2 lever (for use w/ripper)
- Instrument panel guard (for use w/canopy ROPS/FOPS)
- Lights, 2 additional, ROPS mounted
- Mirrors, 2 pcs exterior (for use w/cab)
- Operator platform covers (for use w/canopy ROPS/FOPS)
- Ripper multi-shank w/hydraulic pitch – ripper shank w/pin, max. 3
- Ripper, single shank w/hydraulic pitch
 - ripper shank, standard dig
 - ripper shank, deep dig
 - pin puller, hydraulic
- Seat, air suspension, vinyl cover (for use w/Canopy ROPS/FOPS)
- Sound suppression package
- Starting aid, ether
- Starting/charging receptacle plug assembly with 15 ft cable
- Sun visor in cab
- Tools – metric, in metal box
- Tools – inches, in metal box
- Track shoes:
 - 660 mm (26") severe service
 - 800 mm (31.5") severe service (not recommended to use with ripper)
- Vandalism protection

Specifications subject to change without notice. Illustrations and pictures may include optional attachments and accessories and may not include all standard equipment.

DRESSTA co.Ltd.

Kwiatkowskiego 1, 37-450 Stalowa Wola, P O L A N D
tel: +48 15 813 5252, 813 4556 fax: +48 15 844 4714
www.dressta.com.pl