

ISSN 2709-3948

# 海洋法律与政策

## *Marine Law and Policy*

服务海南自由贸易港 *Serving the Hainan Free Trade Port*

2021 年第 1 期 总第 1 期 (季刊)

Volume 2021 Number 1 ( Quarterly )

《海洋法律与政策》编辑部

*Marine Law and Policy* Editorial Board



## 编辑委员会

(按姓氏拼音顺序排列)

陈明添

丁磊

韩龙

黄硕琳

姜弘

刘丹

吕锦山

秦天宝

唐晓晴

刁晓东

王海南

吴继陆

杨剑

张海文

张丽英

赵振华

周成瑜

邹立刚

陈宪中

傅岷成

韩燕

何丽新

金永明

刘惠荣

吕文正

申亚平

唐议

王崇敏

王丽英

辛礼学

杨泽伟

张健华

张文广

郑韶武

周健

朱玲

初北平

高之国

黄海俊

贾宇

李耀光

刘楠来

彭垒

唐建业

田士臣

王冠雄

王曦

邢广梅

余敏友

张良福

张新军

郑旭廷

周建闽

## **EDITORIAL COMMITTEE**

(In Alphabetical Order of Surname)

CHEN Mingtian	CHEN Xianzhong	CHU Beiping
DING Lei	FU Kuenchen	GAO Zhiguo
HAN Long	HAN Yan	HUANG Haijun
HUANG Shuolin	HE Lixin	JIA Yu
JIANG Hong	JIN Yongming	LI Yaoguang
LIU Dan	LIU Huirong	LIU Nanlai
LU Chinshan	LV Wengheng	PENG Lei
QIN Tianbao	SHEN Yaping	TANG Jianye
TANG Xiaoqing	TANG Yi	TIANShichen
TOU Xiaodong	WANG Chongmin	WANG Guanxiong
WANG Hainan	WANG Liying	WANG Xi
WU Jilu	XIN Lixue	XING Guangmei
YANG Jian	YANG Zewei	YU Minyou
ZHANG Haiwen	ZHANG Jianhua	ZHANG Liangfu
ZHANG Liying	ZHANG Wenguang	ZHANG Xinjun
ZHAO Zhenhua	ZHENG Shaowu	ZHENG Xuting
HOU Chengyu	ZHOU Jian	ZHOU Jianmin
ZHOU Ligang	ZHU Ling	

## 编辑部

### 创刊主编:

傅崐成

### 共同主编:

赖来焜, 台北世新大学, 台北

韩立新, 大连海事大学, 大连

翁文挺, 澳门大学, 澳门

戴锡崑, 联合国际学院, 珠海

傅崐成, 海南大学, 海口

### 副主编:

任雁冰, 大成律师事务所, 广州

魏德才, 海南大学, 海口

高婧如, 海南大学, 海口

张红宽, 海南大学, 海口

### 资深编辑:

罗暹芸, 庞从容

### 编辑:

李家欣

### 副编辑:

辜勒佳, 韩淑越, 姚旭

## **EDITORIAL BOARD**

### **Founding Editor-in-Chief:**

FU Kuen-chen

### **Co-Editors-in-Chief:**

LAI Laikun, Shih Hsin University, Taipei

HAN Lixin, Dalian Maritime University, Dalian

WENG Wenting, University of Macau, Macau

TAI Sik Kwan, United International College, Zhuhai

FU Kuen-chen, Hainan University, Haikou

### **Associate Editor:**

REN Yanbing, Guangzhou Dentons Law Offices, Guangzhou

WEI Decai, Hainan University, Haikou

GAO Jingru, Hainan University, Haikou

ZHANG Hongkuan, Hainan University, Haikou

### **Senior Editors:**

Regina LUO      PANG Congrong

### **Editor:**

LI Jiabin

### **Associate Editors:**

GU Renjia      HAN Shuyue      YAO Xu

## 编者言

海洋法治建设是实现 21 世纪海上丝绸之路战略构想的重要基础，同时也是确保中国（海南）自由贸易港建设行稳致远的重要保障。随着《海南自由贸易港建设总体方案》的正式发布，标志着中国（海南）自贸港建设全面启动。在积极响应建设海南自贸港推进 21 世纪海上丝绸之路建设的大背景下，海南大学国际海洋法律和争端解决中心(HNU-CISLDS)结合大中华地区兄弟院校创办了《海洋法律与政策》(Marine Law and Policy), ISSN: 1709-3948, 以期为大海法学界同仁以及实务界朋友提供交流的平台。

本期《海洋法律与政策》刊发的论文包括了海洋政策与公私海洋法律的几个重大新问题热点。特别是来自香港与台湾的学者专家，分别针对港台地区港口管理，进行了田野调查，发表了他们的研究报告，对于建设海南自由港以及推进 21 世纪海上丝绸之路的建设，有着特殊重要的意义。

吕锦山教授是香港理工大学物流与海事系教授、董浩云国际海事研究中心主任。他与他的团队成员，于 2019 年针对香港集装箱码头附近居民、航运公司员工以及集装箱码头工人，进行了一项探索性强的问卷调查。试图利用因素分析，来确认一个集装箱港口可持续的关键标准。此外，他们还利用结构方程模型来检测多种可持续性之间的关系。论文报告称：在各种相关因素中，与“雇员的工作安全和保障”、“码头交通事故的预防”有关的社会因素，是最重要的可持续性标准。其次才是与“确保货物处理安全有效”、“提供就业机会”及“促进就业活动”等有关的经济因素。这对于海南发展自由贸易港的未来可持续发展，有着不可忽视的参考价值。

无人船的运行已经是一个不可忽视的新趋势。大连海事大学法学院副院长韩立新教授与她的博士生夏文豪就中国政府以及相关行业应对无人船技术所带来的挑战，已经提出的相关政策、规范、标准与法律文献，进行了检讨，并且发现一些规则还需要修改或补充。中国海事管理的法律规则和海商法的主要制度对于无人船的适用，也存在一定的问题。文章提出了相应的宝贵建议。

台湾海洋大学航运管理学院的曾柏兴助理教授，面对面地访谈了 16 位来自台湾三大港口（高雄港、基隆港、台中港）的专业人士，详细讨论了包括氮氧化物、二氧化硫、二氧化碳、一氧化碳、悬浮微粒、挥发性有机物等的港区排放问题。研究发现：为达成资源的合理运用及环境平衡，绿色港口的发展必须更广泛地重视港口的规划以及空气污染减量策略，包括岸电系统、低硫燃料、炭税、进港减速、港区空气品质标准、执行 MARPOL 等国际公约之类的事务均须按照绿色港口的需要，弹性设计和管理。

在《联合国海洋法公约》中无害通过与航行自由是重要的规范内容。自然资源部海洋发展战略研究所的贾宇博士是国内长期研究军舰的无害通过制度的专家。她针对目前比较敏感的军舰航行自由与无害通过问题，进行了文献与政策的深入研究，

证明了中国长久一以贯之的立场，并从法理上解析其法律性质，认为中国法律要求外国军舰通过中国领海必须事先取得中国政府的批准，这是一种附条件的无害通过。

本期还刊登了大连海事大学法学院阎铁毅教授与研究生马琨针对海警机构的行政属性问题所撰写的研究报告。自党的十八大以来，中国成立了统一的海警机构并进行了相关的系列改革。其中关于进入武警序列的海警，是否应该成为行政主体的问题，受到了一些外国媒体的炒作。本论文言简意赅地分析了这一问题，并且得到了肯定的答案。对于目前仍在征求公众意见的《海警法（草案）》，作者也提出了一定的具体建议。

作为初创的海洋法律与政策专业刊物，本期《海洋法律与政策》还在“案例解析”的栏位介绍了两个案例。郭中元和俞世峰两位先生合写的有关专属经济区外籍船舶碰撞的海难救助和油污损害责任问题（2019年交通运输部上海打捞局诉普罗旺斯船东2008-1有限公司、法国达飞轮船有限公司、罗克韦尔航运有限公司海难救助与船舶污染损害责任纠纷案）的案例评析；以及郭中元先生所写有关海域使用权出让合同约定“到期不续约”的效力问题（2019年江苏瑞达海洋食品有限公司诉江苏盐城市大丰区人民政府等海域使用权行政许可纠纷案）的案例评析。

作为海洋法律与政策领域内的新刊物，我们诚挚欢迎各位的批评指教。您的来稿，无论是以学术或非学术论文的形态，或者是以案例评析的形式撰成的，也不论是涉及海洋、船舶、航线、港口、海洋环境与海事管辖权等任何主题的作品，都将为我刊高度重视，并以中英两种语文刊发。

编辑部 谨识



## EDITOR'S NOTE

Rule of law at the sea is the basis of the 21<sup>st</sup> Century Maritime Silk Road Initiative. It is also the safeguard for the eventual success of the Hainan Free Trade Port project. Together with promulgation of the General Plan for Constructing Hainan Free Trade Port, the project has officially been launched. In such grand circumstances, Hainan University Center for International Sea Law and Dispute Settlement (HNU-CISLDS) has invited five other outstanding institutes in the Grand China area to jointly publish this journal, *Marine Law and Policy* (ISSN 1709-3948). The purpose is to create an open platform for exchanging ideas among the academics and practitioners.

In this first issue of *Marine Law and Policy*, we have included articles on several newer hot subjects. Particularly we have two authors from Hong Kong and Taiwan. They implemented their respective researches with field studies on management of the HK Port and Taiwan's three major ports. The two authors' reports are of significant value for the Hainan Free Trade Port construction and the 21<sup>st</sup> Century Maritime Silk Road Initiative.

Professor LV Jinshan is a professor at the Department of Logistics and Maritime Studies of the HK Polytechnic University and Director of the C.Y. Tung International Centre for Maritime Studies. Together with his team members, in March 2019, he collected data with a detailed questionnaire survey from 144 respondents. They are residents near the Hong Kong containers dock, shipping companies' employees and container terminal workers. An exploratory factor analysis and confirmative factors analysis lead to the crucial sustainability criteria of the HK container port. Also, Professor LV and his team applied a structural equation modeling to examine the relationship among the multiple sustainability dimensions. In their report, the authors pointed out that the social aspects with respect to "employee job security and safety" and "terminal traffic accidents prevention" were ranked as the most important sustainability criteria, followed by economic aspects of "ensuring cargo handled safely and effectively", "offering employment opportunities" and "facilitation of economic activities". This conclusion is truly not negligible for the sustainable development of Hainan Free Trade Port.

Operation of autonomous ships is already a realistic challenge in the maritime circle. Professor HAN Lixin, Associate Dean of the Dalian Maritime University Law School, wrote with assistance from her Ph.D. student, XIA Wenhao, this article on the Chinese policies and regulations of this new subject matter. They reviewed and pondered over the relevant policies, norms, criteria and legal rules, and found that several regulations in China need amendment or supplement. The Chinese maritime management rules and the current Maritime Law have also some issues. This article offers valuable suggestions to respond to these issues.

Professor ZENG Po-xing of Taiwan Ocean University Department of Shipping and Translation Management, interviewed with 16 practitioners from the three major ports in Taiwan, ie, Gaoxiong Port, Keelung Port and Taichung Port. They focused their talks on emission of NO<sub>x</sub>, SO<sub>2</sub>, CO<sub>2</sub>, CO, PM, VOC from ships and trucks in the port area. His

research found that to ensure reasonable utilization of resources and balancing the environment, a green port has to expand its planning area and emphasize more its air pollution mitigation strategies, that would include shore power system, low sulphur fuel, carbon tax, reduced speed when arriving at the port, air quality standards within port area, and implementation of international conventions like MARPOL. All should be more flexibly designed and managed according to a green port demand.

Innocent passage and freedom of navigation have been repeatedly emphasized in the UNCLOS. Dr. JIA Yu from the Ocean Development Strategy Institute, Ministry of Natural Resources is an expert in the field of warships innocent passage issues. She carried out documentary and practical researches on this sensitive issue and found that China's legal opinion on warships' innocent passage has been a long term position. Also she has characterized the legal position of Chinese government requiring foreign warships to obtain permits prior to their innocent passage through Chinese territorial seas as a kind of conditional innocent passage.

Professor YAN Tieyi of Dalian Maritime University and his graduate student MA Kun researched and contributed their short report on the legal status of the Chinese Coast Guard. After the 18<sup>th</sup> CPC national Congress, China has established a unified coast guard agency and carried out a series of reform. One of the issues involved in these reforms and sensitively noticed by foreign media is whether the coast guard should be regarded as an administrative subject after its being included into the arm forces in China. This article briefly discussed the issue and found its conclusion that the newly reformed Chinese Coast Guard should be regarded as an administrative subject. The authors also offered some substantive suggestions for the recently publicized Coast Guard Law (draft).

In this issue we also introduced two case reviews. Mr. GUO Zhongyuan and Mr. YU Shifeng reviewed a case on salvage and liability concerning oil pollution caused by collision of foreign vessels in the EEZ (Shanghai Salvage Bureau of Ministry of Transportation v. Provence Shipowner 2008-1 Ltd., CMA CGM SA, Rockwell Shipping, Ltd., 2019). Mr. GUO Zhongyuan also reviewed another case with respect to the legal effects of the clause of "no extension after expiration of the contract" in a contract of sea area use (Jiangsu Ruida Food Company, Ltd. v. People's Government of Yancheng City Dafeng District and Dafeng District natural Resources and Planning Board).

As a new journal in the field of marine law and policy, we sincerely welcome your comments. Any contributions from you in the form of academic or non-academic articles or case reviews, on any subjects concerning the sea, the vessel, the route, the port, the marine environment and maritime jurisdiction will be highly appreciated for publication in our journal in both Chinese and English.

**MLP Editorial**

# 目 录

## Table of Contents

### 论文 (Articles)

- 评估港口可持续性标准和利益相关者保留.....吕锦山, 鄺钧榆, 盧锦慧, 岑美瑩 (1)  
Assessing Port Sustainability Criteria and Stakeholder's Rention .....  
..... LU Chin-Shan, KWONG Kwan Yu., LO KamWai, SHUM Mei Ying (23)
- 中国无人船的政策与法律规则应对.....韩立新, 夏文豪 (47)  
Autonomous Ships in China: Policies and Regulations.....  
.....HAN Lixin, XIA Wenhao (61)
- 低空污排放港埠管理: 政策观点.....曾柏兴 (77)  
Low Emission Port Development: The Policy Perspective.....Po-Hsing TSENG (86)
- 关于军舰无害通过问题的再认识.....贾宇 (97)  
Rethink About the Right of Innocent Passage of Warships.....JIA Yu (108)
- 论《海警法(草案)》背景下海警机构的行政属性.....阎铁毅, 马琨 (122)  
The Administrative Attributes of Coast Guard Agencies in the Context of "*The Coast Guard Law (Draft)*" .....YAN Tieyi, MA Kun (127)

### 案例评析 (Case Review)

- 专属经济区外籍船舶碰撞的海难救助和油污损害责任问题.....俞世峰, 郭中元 (133)  
Marin Salvage and Liability Concerning Oil Pollution Damage Caused by the  
Collision of Foreign Vessels in the EEZ.....GUO Zhong Yuan, YU Shiefeng (138)
- 海域使用权出让合同约定“到期不续期”的效力认定.....郭中元 (144)  
Contract of Sea Area Use with Non-Extension Clause.....GUO Zhong Yuan (147)

### 新发展与新文献 (Recent Developments and Documents)

- ITLOS, Reconstitution of the Chambers of the Tribunal.....(150)
- UNCTAD, Review of Maritime Transport 2020. ....(154)
- 第 75 届联合国海洋和海洋法秘书长的报告. ....(155)
- 船舶船员新冠肺炎疫情防控操作指南.....(172)

### 附录(Appendix)

- 《海洋法律与政策》稿约.....(208)  
*Marine Law and Policy* Call for Papers.....(209)



# 评估港口可持续性标准与利益相关者保留 ——以香港为例

吕锦山\* 鄺鈞榆\*\* 盧錦慧\*\* 岑美瑩\*\*

**摘要:** 本文研究的主要目的是,在香港集装箱港口背景下,评估可持续性的关键标准和利益相关者的影响。数据收集基于一份来自集装箱码头附近居民、船运公司员工和集装箱码头工人等 144 位受访者的问卷调查。这种探索性因素分析和确认性因素分析在于认定集装箱港口可持续性的关键标准。此外,还应用了结构方程模型以检测可持续性维度之间的关系,如环境可持续性、社会可持续性、经济可持续性和利益相关者的保留。结果显示,与“雇员的工作安全和保障”“码头交通事故预防”有关的社会因素被列为最重要的可持续性标准。其次才是与“确保货物处理安全有效”“提供就业机会”和“促进就业活动”等有关的经济因素。结果还表明,环境和经济维度对利益相关者的保留具有重大影响。在这项研究中还讨论了港口可持续实务的实践意义。

**关键词:** 港口 可持续性 利益相关者 保留

## 一、引言

随着国际贸易的迅速发展,世界集装箱吞吐量的增长率提高了 2.6%,2018 年达到了 1.52 亿标准箱。<sup>1</sup>集装箱港口在供应链网络中起着至关重要的作用,并在海上运输和内陆运输之间建立了重要的联系。然而,大量地需求也反映着集装箱货物量的增加,引起了人们对环境、安全、人类健康方面负面影响的担忧。因此,港口当局应当将可持续性发展作为其组织目标之一,维护环境、社会和经济问题之间的平衡。最近,港口可持续性已日益引起港口组织的关注<sup>2</sup>和现有的港口研究<sup>3</sup>。大多

\* 吕锦山现为香港理工大学物流及海事学系教授及副系主任,以及董浩云国际海事研究中心主任。电子邮箱: [chin-shan.lu@polyu.edu.hk](mailto:chin-shan.lu@polyu.edu.hk)

\*\*鄺鈞榆, 盧錦慧, 岑美瑩, 现为香港理工大学物流及海事学系学生。

©THE AUTHOR AND MARINE LAW AND POLICY

<sup>1</sup>联合国贸易和发展会议:《2019 年海上运输评论》,联合国发表:纽约和日内瓦(2019 年)。

<sup>2</sup> 国际港口协会(IAPH),《2018-2019 年度报告(2020)》。摘自

[http://www.iaphworldports.org/iaph/wp-content/uploads//publications/Annual\\_Report\\_2018-2019.pdf](http://www.iaphworldports.org/iaph/wp-content/uploads//publications/Annual_Report_2018-2019.pdf) 新加坡海事和港口管理局(MPA):《海事可持续报告指南——最佳创新实践海事可持续发展报告》,2019 年第 01 期。[https://api2.sgx.com/sites/default/files/2019-09/MPA\\_Sustainability\\_Guidebook.PDF](https://api2.sgx.com/sites/default/files/2019-09/MPA_Sustainability_Guidebook.PDF) 洛杉矶港,《洛杉矶港空气排放量清单——2018(2019)》。[https://kentico.portoflosangeles.org/getmedia/0e10199c-173e-4c70-9d1d-c87b9f3738b1/2018\\_Air\\_Emissions\\_Inventory](https://kentico.portoflosangeles.org/getmedia/0e10199c-173e-4c70-9d1d-c87b9f3738b1/2018_Air_Emissions_Inventory)。

<sup>3</sup> Acciaro, M., 《港口部门的社团责任和价值创造》,载《物流研究与应用国际期刊》,2015 年第 18 卷第 3 期,第 291-311 页。Ashrafi, M., Acciaro, M., Walker, T. R., Magnan, G. M., and Adams, M., 《加拿大和美国海港的社团可持续性》,载《清洁生产杂志》,2019 年第 220 期,第 386-397 页。Darbra, R. M., T. Pittam, K. A. Royston, J. P. Darbra, and H. Journee, 《欧洲港口环境监测要求调

数现有研究从港口当局或承运人的角度来审查海港的可持续性,而以往的文献很少关注港口附近居民的意见。据我们所知,在港口可持续性研究的背景下,港口可持续性对利益相关者保留的影响尚未被检测和验证。

因此,本研究旨在确定香港集装箱港口可持续性的关键标准和利益相关者的影响。香港葵青是沿着青岛岛与葵涌之间的蓝巴勒海峡行驶的主要集装箱货柜港区。它覆盖 279 公顷,总码头深度 7684 米。共有 24 个集装箱泊位,到 2019 年将提供约 1830 万个标准箱<sup>1</sup>。而葵青货柜码头造成了严重的空气污染。2019 年,葵涌地区的二氧化氮年平均值达 54 微克/立方米,高于香港年限值(40 微克/立方米)<sup>2</sup>。2017 年,船舶的 SO<sub>2</sub>、NO<sub>x</sub>、RSP 和 FSP 分别占总排放量的 52%、37%、34%和 41%。2019 年,香港水域内外共发生 459 起事故,其中有 9 人遇难和 31 人失踪。<sup>13</sup>这反映出香港港口当局所面临的可持续性问题。

本文共分为五个部分。引言之后,将以文献综述和先前的研究为背景,挑选一些可纳入我们研究中的可持续性标准。然后,在研究方法部分将讨论主要数据的收集方法,以获得进一步分析所需要的相关信息。结果部分提供因子分析的结果和结果方程模型的解释。最后一部分是对可持续性政策建议地讨论和结论进行探索。

## 二、文献综述

### 1.可持续发展的定义

可持续性发展关系到现状的满足,而不损害满足子孙后代需求的能力。可持续性概念有三大支柱:环境、社会和经济。港口可持续性是指既能保护港口业务活动,又能维持港口和利益相关者当前和未来对人力和自然资源满足的需求。<sup>3</sup>集装箱港口可持续性有三个基本的和重要的因素:社会可持续性、经济可持续性和环境可持续性,这些都与集装箱港口运营息息相关。<sup>4</sup>

---

查情况》,载《环境管理期刊》,2009 年第 90 卷第 3 期,第 1396-1403 页。Lim, S., Pettit, S., Abouarghoub, W. and Beresford, 《港口的可持续与管理》,载《运输研究第四部分:运输与环境》,2019 年第 72 期,第 47-64 页。Lu, C. S., Shang, K. C. and Lin, C. C., 《确认关键的集装箱港口可持续评估标准》,载《海事实务研究》,2016 年第 2 卷第 1 期,第 90-106 页。Oh, H., Lee, S.W. and Seo, Y. J., 《海港可持续性评价:以韩国为例》,载《海洋与沿海管理》,2018 年第 161 期,第 16-50 页。Seuring, S. and Muller, M., 《从文献综述到概念性框架——可持续性供应链管理》,载《清洁生产杂志》,2008 年第 16 卷第 15 期,第 1699-1710 页。Wooldridge, C. F., McMullen, C. and Howe, V. 《港口和港湾的环境管理——通过科学监控执行政策》,载《海洋政策》,1999 年第 23 卷第 4-5 期,第 413-425 页。

<sup>1</sup> 海事处,《香港港口集装箱吞吐量——香港特别行政区政府(2020)》,摘自 <https://www.mardep.gov.hk/en/publication/portstat.html#5>。

<sup>2</sup> 环境保护部,《2019 年香港空气质量:数据和空气污染物排放清单——香港特别行政区政府(2020)》,摘自

[https://www.epd.gov.hk/epd/english/environmentinhk/air/data/emission\\_inve.html#emission\\_trends](https://www.epd.gov.hk/epd/english/environmentinhk/air/data/emission_inve.html#emission_trends)

<sup>3</sup> Gul, D.S. and Cimen, K.C., 《港口可持续性和利益相关者管理的供应链:基于资源依赖理论框架》,载《亚洲航运和物流杂志》,2012 年第 28 期,第 301-320 页。

<sup>4</sup> Yap, W.Y. and Lam, J.S.L., 《相当于 8000 万英尺的集装箱港口?港口和沿海开发中的可持续问题》,载《海洋与沿海管理》,2013 年第 71 卷第 2 期,第 13-25 页。

## 2.可持续性评价标准

许多国际组织（如联合国全球契约、经济合作与发展组织等）对可持续发展有不同的原则。不同的国际港口都制定了可持续性评估标准。国际标准组织（ISO）评估可持续发展标准包括环境法规政策和自我评价管理机制体系（参见 ISO 网站）。但是，本研究并未考虑到当地居民和承运人的意见。其中有几个方面可以用来衡量社会可持续性，如人权、员工和工作场所的安全和保障，以及社会发展等。<sup>1</sup>因此，可持续性评估由社会可持续发展、经济可持续性发展和环境可持续性发展组成。

社会层面、经济层面和环境层面都与可持续发展相关联，而之前的研究仅仅关注的是环境层面包括空气质量、绿色气体排放、二氧化碳排放、再循环和废物利用、闪电缓解、噪音污染和水质量等。同时，可持续评估标准的经济层面有，当地经济活动发展、就业发展、公平竞争等。对于社会层面而言，涉及几个评估项目包含港口可达性、员工安全与保障、港口伙伴沟通等。随着公众意识和公众参与度的提高，利益相关者的反应被港口可持续发展考虑在内。2015年，Shiau 和 Chuang 提出了由当地居民和立法者选择的 34 个港口可持续性评估标准指标。<sup>2</sup>因此，在之前的研究包括环境层面、社会层面和经济层面中，共有 14 个可持续评估标准指标被用于本课题研究。

## 三、方法论

本研究的目的在于通过审查可持续性标准的重要性和评估港口工人、船舶公司工人和当地居民的所在码头的情况表现，以调查和确定葵青港集装箱码头的重要的可持续性标准。该方法是通过设置问卷调查，然后再与船舶公司管理者的个人访谈来完成。

### 1.问卷的设计和措施的确定

从可持续发展报告和研究中得出可持续性评估标准，设计问卷调查，并将其发布给港口工人、船舶公司和居民。对于问卷调查的设计，首先被指定的基本信息和被列出的问题是：问卷的类型、个别问题的内容、回答的形式。为了进一步明了，问卷问题的用语、问题的顺序和可持续性标准的特征都将被确切地有序地排列在问卷中。

此外，通过文献综述和相关港口专家学者间的访谈来核查问卷内容的有效性。为确保与原始的英文问卷一致，问卷还被翻译成中文以方便对港口工人、船舶公司和居民进行调查访谈。结果对一些评估标准的措辞做了细微的修改，并在修订了可持续发展标准后被接受。针对每个要素使用五分制评级量表，其中 1 代表不重要，2 代表不重要，3 代表既不同意也不反对，4 代表重要，5 代表非常重要，基于港口工人、船舶公司和当地居民的立场来认定和评判可持续性评估标准的重要性。

<sup>1</sup> McIntosh, M., Thomas, R., Leipziger, D. and Coleman, G., 《现存企业公民追寻企业社会责任战略路线》，普伦蒂斯·霍尔出版社 2003 年版。

<sup>2</sup> Shiau, T.A. and Chuang, C.C., 《港口可持续性发展指标的社会建设：基于基隆港案例研究》，载《海事政策与管理》2015 年第 42 卷第 1 期，第 26-42 页。

使用 SPSS 25.0 软件来进行数据分析。

## 2. 研究样本

在本课题中, 研究样本取自于居民、港口工人、船运公司工人和管理人员, 这些人是确认和决定可持续性评估标准的重要指标, 因为他们正生活在港口周边并分别参与到达港口的最前线。在 2019 年 3 月份, 通过谷歌的形式共完成 150 份问卷调查, 其中每位受访者发放了 50 份副本。这个调查共收集到居民和航运公司工人各 50 份, 港口工人共 44 份问卷。最终, 所有 150 份可用的回复有 144 份。

通过街头访谈的方式对港口工人和居民进行问卷调查。通过谷歌形式在平板电脑和 iPad 上显示问卷, 并邀请居住在青衣及荔景的居民以及在葵青货柜码头工作的集装箱货柜码头的港口工人来完成问卷。2019 年 3 月 19 日下午, 和 50 位居民和 50 位港口工人进行了总共 100 次街头访谈以证实这些问卷。

## 3. 研究方法

本研究中有大量的研究报告被改编。描述性统计和探索性因素分析被用来将大量的可持续性属性分类为一组具体的潜在因素和维度<sup>1</sup>。此外, 我们的研究还进行了一项可靠性测试以评估这些规模的合理性。另外, 验证性因素分析(CFA)被用来检验测量模型。结构方程建模软件 AMOS 的参与也有助于分析测量模型, 审视心理测量学特性并消除潜在变量与建议措施之间的关系。最终, 一种方差分析方法(ANOVA)同样被用于在可持续性标准重要性水平基础上寻找出港口工人、船员公司和当地居民之间存在的差异。

通过结构方程建模软件 AMOS 软件, 这种模型也可以显示居民、船运公司和港口运营商之间在因素和保留之间的关系。对于这三个利益相关者而言, 葵青集装箱货柜码头的保留是非常重要的。为找出居民继续生活在葵青区的趋势, 有三个问题被提出来。分别是“从某种程度上讲, 我对葵青区的居住环境、葵青区的工作环境和葵青集装箱货柜码头提供的服务感到满意”; “从某种程度上讲, 我从来没有打算过离开葵青区、放弃在葵青货柜码头的工作或去使用其他地方的其他港口服务”; “从某种程度上讲, 我推荐人们在葵青去居住、在葵青货柜码头工作、使用葵青货柜码头的服务”。上述问题旨在评估葵青货柜码头和不同利益相关者之间的保留。从居民的角度来看, 留在葵青区的意愿程度代表着葵青货柜码头的保留程度。“从船运公司的角度来看, 想要继续使用葵青货柜码头提供服务的意愿代表着葵青货柜码头的保留程度。”“从港口工人的角度来看, 愿意长远地在葵青集装箱码头工作的程度代表着葵青货柜码头的保留程度。”

## 四、结果

---

<sup>1</sup> Hair, J.F., Black, W.C., Babin, B.J. and Anderson, R.E., 《多元化数据分析》(第七版), 美国新泽西州上萨德里弗: 普伦蒂斯-霍尔出版社 2010 年版。



#### 4.1. 受访者资料

如图表 1 所示, 受访者的个人资料显示, 占多数受访者类型的是居民和港口工人 (各自占 50%), 其次是占 44% 的船运公司工人。本研究一直试图认定和评估环境、社会和经济方面的可持续性标准, 通过介绍他们的观点, 这三种主要类型的受访者发挥着重要作用。

据数据统计, 多数受访者中, 年龄在 30-49 岁之间的居民、港口工人和船运公司工人占 38%; 年龄在 18-29 岁之间的居民、港口工人和船运公司工人占 33%; 年龄在 50-64 岁的占 23%; 年龄在 65 岁以上和年龄在 17 岁以下的各占 3%。

就任期而言, 结果显示, 在公司服务 5-9.99 年的占 29%; 在公司服务 10-14.99 年的占 26%; 在公司服务 15 年以上的占 27%; 在公司工作 1-4.99 年的占 15%; 在公司工作不到 1 年的占 3%。

就教育而言, 受访者中拥有大学本科及以上学历的占 34%; 拥有大专文凭的占 31%; 高中毕业的占 25%; 初中及以下学历的占 10%。

就收入而言, 绝大多数受访者每月收入 15000-19999 美元的占 34%; 受访者每月收入 20000-29999 美元的占 22%; 受访者每月收入 30000-49999 美元的占 15%; 受访者每月收入 50000 美元或以上的占 11%; 受访者每月收入 10000-14999 美元的占 10%; 受访者每月收入低于 10000 美元的占 8%。

表 1 受访者资料 (N=144)

	受访者资料	频率	百分比
类型	居民	50	35
	船运公司	44	30
	港口工人	50	35
年龄	17 岁或以下	4	3
	18-29 岁	48	33
	30-49 岁	55	38
	50-64 岁	33	23
	65 岁或以上	4	3
任期	不到 1 年	5	3
	1-4.99 年	21	15
	5-9.99 年	42	29
	10-14.99 年	37	26
	15 年或以上	39	27
教育程度	初中或以下	15	10
	高中	36	25
	大专	44	31
	大学本科或以上	49	34

收入	\$10000 以下	12	8
(港币)	\$10000-14999	15	10
	\$15000-19999	48	34
	\$20000-29999	32	22
	\$30000-49999	21	15
	\$50000 或以上	16	11

## 4.2.重要性——绩效分析

重要性绩效分析（IPA）是一种被广泛接受地用来衡量服务质量的方法，目的在于确定哪些会对客户满意度产生较大影响，并能影响到客户的忠诚度。实施 IPA 分析，对于明确确定可持续性标准是至关重要的。本研究中，共选取 12 项可持续性标准来进行调查。根据预先确定的标准，可分为两个方面：（1）各个标准的重要性；（2）绩效的判断。

### 4.2.1 集装箱码头可持续性评估标准的相对重要性

集装箱码头可持续性评估标准的相关性已在我们的分析中，并据平均得分进行了排名。表 2 中显示的平均排名从根本不重要（得分=1）到非常重要（得分=5）。分数最高甚至超过 4.4 分的三个标准分别是“员工工作安全与保障”、“码头交通事故预防”、“确保货物处理安全有效”。另外，大多数标准如提高就业机会方面一般情况下分数会超过 4.0。另一方面，分数最低（平均得分为 3.33）的两个标准分别是“提升码头景观”和“提供公平就业机会”。从排名可以看出，按照访谈者包括港口工人、葵青区居民和船运公司的观点，可持续性的所有三个维度都受到高度赞扬。

### 4.2.2 集装箱码头可持续性评估标准的相对绩效

本研究从三个可持续性方面调查集装箱码头可持续性评估标准绩效：经济、社会和环境方面。受访者被要求对葵青码头的可持续性绩效和被评出的 14 个可持续性标准发表观点。在表 3 中显示的平均得分范围是从根本不重要（得分=1）到非常重要（得分=5）。绩效得分最高的三个标准分别是“确保货物处理安全和有效”（得分为 4.15）、“提供就业机会”（得分为 3.97）、“促进经济活动”（得分为 3.87）。通过三方面的数据整合，受访谈者的观点分值从 2.35 到 4.15，这表明从可持续性措施三个维度来看，葵青集装箱码头的绩效参差不齐。相比较而言，受访谈者认为以下三个可持续性指标的绩效最低：“减轻葵青区噪音污染”、“减弱对邻居的光线影响”（两者的平均分值为 2.83），和“在货物处理时考虑实施 3R（减少、再利用、再循环）”（平均分值为 2.35）。

表 2. 受访谈者对港口可持续性评估标准的重要性

等 代			
级 码	标准	平均值	标准差

1	I4	员工工作保障与安全	4.47	0.68
2	I5	码头交通事故预防	4.42	0.73
3	I2	确保货物处理安全和有效	4.40	0.74
4	I3	提供就业机会	4.38	0.73
5	I1	促进经济活动	4.25	0.77
6	I12	维护葵青区空气质量	4.20	0.79
7	I11	在货物处理时考虑 3R (减轻、再利用、在循环)	4.17	0.89
8	I14	确保正确处理废物	4.15	0.84
9	I13	码头区域的生态环境保护	4.06	0.85
10	I9	葵青区的废水处理和水质保护	4.05	0.94
11	I10	减弱对邻居的光线影响	3.76	0.84
12	I7	减轻葵青区的噪音污染	3.65	0.95
13	I6	提升集装箱码头的景观	3.33	0.88
14	I8	提供公平就业机会	3.33	0.94

表 3. 受访读者对港口可持续性评估标准的评估

等级	代码	标准	平均值	标准差
1	P2	确保货物处理安全和有效	4.15	0.70
2	P3	提供就业机会	3.97	0.74
3	P1	促进经济活动	3.87	0.77
4	P4	员工工作保障与安全	3.26	1.25
5	P5	码头交通事故预防	3.25	1.19
13	P6	提升集装箱码头景观	3.02	0.78
6	P9	葵青区的废水处理和水质保护	2.95	1.06
7	P12	维护葵青区空气质量	2.94	1.12
8	P14	确保正确处理废物	2.93	1.17
9	P13	码头区域的生态环境保护	2.89	0.99
14	P8	提供公平就业机会	2.89	1.08
10	P7	减轻葵青区的噪音污染	2.83	1.12
11	P10	减弱对邻居的光线影响	2.83	1.08
12	P11	在货物处理时考虑 3R (减轻、再利用、在循环)	2.35	1.00

#### 4.2.3 重要性和绩效的关系

图 1 显示每个标准的重要性的集中趋势将被分配和用作绘制被划分为四个象限的二维网格的属性和坐标。

在矩阵中的每个象限被按照在垂直轴上从高到低的重要性平均分标准 (4.05) 和在横轴上从高到低的绩效平均分标准 (3.15) 分布。在这个图中清晰地展示了重要性和绩效之间的差异。报告指出,受访读者对可持续性评估标准的满意度是按照

每个标准的相对重要性和绩效将其定位在适当的象限内。

标准的定位可用来解释每个象限内的战略所产生的不同影响，IPA 中的四个象限基于每个象限不同的潜在战略表明不同的情形。象限有：



图 1. 港口可持续性的重要性和绩效矩阵

### (1) 象限 1：高重要性和高绩效

在本研究中，该象限内有五个标准以表示它们的重要性(4.04)和绩效(3.15)高于平均值。它们有：“员工工作保障与安全”的重要性是 4.47，绩效是 3.26；“码头交通事故预防”的重要性是 4.42，绩效是 3.25；“确保货物处理安全有效”的重要性是 4.40，绩效是 4.15；“提供就业机会”的重要性是 4.38，绩效是 3.97；“促进经济活动”的重要性是 4.25，绩效是 3.87。

### (2) 象限 2：高重要性和低绩效

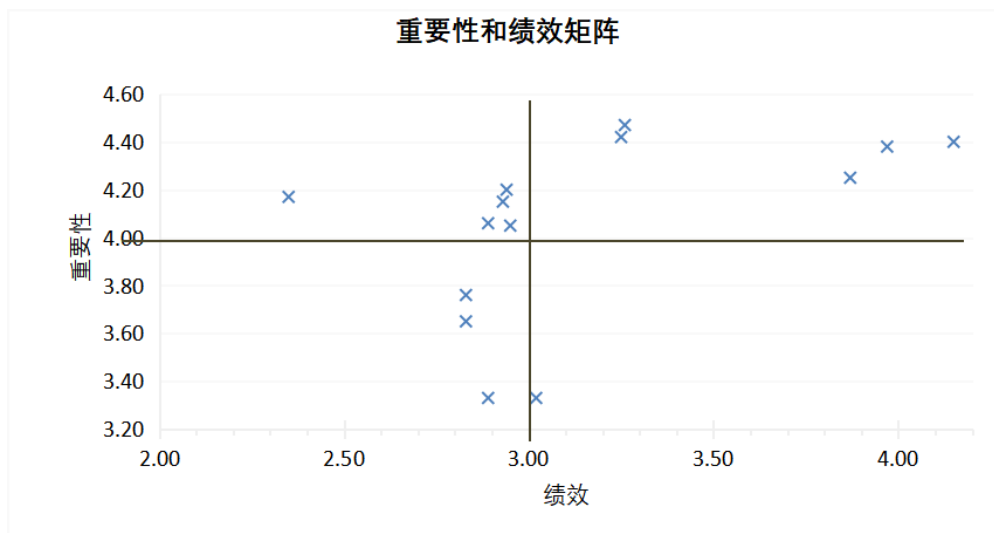
在这个象限内有五个标准与平均分相比，它们有高重要性但却是低绩效。这些标准是：“维护葵青区的空气质量”的重要性是 4.20，绩效是 2.94；“处理货物是考虑 3R (减少、再利用、再循环)”的重要性是 4.17，绩效是 2.35；“确保废物处理适当”的重要性是 4.15，绩效是 2.93；“保护码头地区的生态环境”的重要性是 4.06，绩效是 2.89；以及“葵青区的污水处理和水质保护”的重要性是 4.05，绩效是 2.95。

### (3) 象限 3：低重要性和低绩效

该象限内有四个标准，它们的重要性和绩效都低于平均分。这些标准是：“减弱对邻居的光线影响”重要性是 3.76，绩效是 2.83；“减少葵青区的噪音污染”的重要性是 3.65，绩效是 2.83；“提升集装箱码头的景观”的重要性是 3.33，绩效是

3.02;“提供公平就业机会”的重要性是 3.33, 绩效是 2.89。

#### (4) 象限 4: 低重要性和高绩效

这个象限内的标准表明,与平均分相比,它们的重要性很低但绩效却很高。在本研究中没有任何标准是属于这一象限的。

### 4.3 可持续性评估标准之间的关联性

相关系数的计算可用于测量两个标准之间线性关系的强度和方向(参见表 4)。其计算方法是变量的协方差除以其标准差的乘积。分值越高,两个变量之间的关系越紧密。标准 1——“为经济活动提供便利”,标准 2——“确保货物处理安全有效”,标准 3——“提供就业机会”,它们之间都是相互关联的,标准 1 到标准 2 之间的分值是 0.373,标准 1 到标准 3 之间的分值是 0.364,而标准 2 到标准 3 之间的分值是 0.787。标准 4——“员工工作保障与安全”,标准 5——“码头交通事故预防”,它们之间也是相关联的,其关联值为 0.592,而标准 6——“提升集装箱码头的景观”与标准 4 之间的关联值,相较于其和标准 5 之间的关联值并不显著,分别为-0.140 和-0.043。对于标准 7 到标准 14,它们之间的关联值介于 0.206 到 0.695 之间。

表 4 港口可持续性标准之间的关联性

	I1	I2	I3	I4	I5	I6	I7	I8	I9	I10	I11	I12	I13	I14
I1	1													
I2	0.373**	1												
I3	0.364**	0.787**	1											
I4	0.297**	0.570**	0.458**	1										
I5	0.235**	0.201*	0.247**	0.592**	1									
I6	0.106	0.012	0.022	-0.140	-0.043	1								
I7	0.036	-0.044	-0.086	-0.090	0.057	0.190*	1							
I8	0.012	-0.060	-0.081	-0.054	-0.030	0.116	0.421**	1						
I9	0.320**	0.332**	0.197*	0.293**	0.298**	0.108	0.497**	0.307**	1					
I10	0.016	0.042	0.011	-0.015	-0.018	0.154	0.581**	0.420**	0.619**	1				
I11	0.222**	0.233**	0.199*	0.248**	0.189*	-0.010	0.297**	0.301**	0.660**	0.649**	1			
I12	0.227**	0.326**	0.291**	0.150	0.180*	0.127	0.273**	0.166*	0.580**	0.517**	0.608**	1		
I13	0.296**	0.216**	0.120	0.193*	0.173*	0.133	0.206**	0.247**	0.663**	0.525**	0.497**	0.640**	1	
I14	0.266**	0.276**	0.296**	0.198*	0.275**	0.049	0.344**	0.266**	0.695**	0.594**	0.647**	0.585**	0.555**	1

\*\*关联性在 0.01 水平上是显著的(双侧)

\* 关联性 0.05 水平上是显著的 1 (双侧)

#### 4.4 因子分析和信度测试

探索性因子分析（EFA）被用来分析数据结构，并从测量的变量中消除潜在因子。<sup>1</sup>本研究的样本量是144为受访者和14各目量，这是非常接近建议水平的。用凯泽-迈耶-奥尔金抽样充分性测量(KMO)，该分值应大于0.5，且P值小于0.05，才能被认为是具有重要意义(皮尔斯和勇,2013)。这项研究中的KMO值为0.781，巴特莱特的球形度测试是有重大意义的([ $X^2 = 991.450$ ,  $P < 0.00$ ])，这超出了所要求的水平。

作为重要的特征值和因子载荷的最低水平是1.0和0.5；因子载荷越高，测试变量的解释因素就越好(皮尔斯和勇,2013)。在这些变量中，因子载荷低于0.5的两个因子的变量从先前的分析中被移除——“I6：提升集装箱码头景观”和“I8：提供公平就业机会(就业不受种族、性别等影响)”。

如表5所示，结果表明剩下的12个变量占总方差的68.81%。克隆巴赫系数用来测试可信度，以确保期其可靠性和一致性，而且当指数在0.7以上时被认为是令人满意的。<sup>2</sup>这项研究的所有可接受的三个因素指数均高于0.74。这些因素被标志并描述如下：

因素1，环境可持续性包含七个标准：“I7：减少葵青区噪音污染”，I9：“处置葵青区废水和保持水质”，“I10：减轻对邻居的光线影响”，“I11：处理货物时考虑3R(减少、再利用、再循环)”，“I12：保持葵青区的空气质量”，“I13：保护码头区域的生态环境”，和“I14：确保废物处置适当”。可参照表6，在总方差为40.19%中，I10的因素负载最高，为0.86。

因素2，经济可持续性包含三个标准：“I1：促进经济活动”，“I2：确保安全有效地处理货物”和“I3：提供就业机会”。参照表6，在总方差的19.90%中，I2的因素负载最高，为0.89。

因素3，社会可持续性，包含两个标准：“I4：员工的工作的保障与安全”和“I5：港口交通事故的预防”。参照表6，在总方差的8.73%中，I5的因素负载最高，为0.93。

表5 进行因素分析以确定港口可持续性标准的因素

编号	名称	因素 1	因素 2	因素 3
I1	促进经济活动	0.19	0.54	0.19
I2	确保安全有效地处理货物	0.12	0.89	0.14
I3	提供就业机会	0.04	0.88	0.11
I4	员工工作的保障与安全	0.04	0.48	0.74
I5	中断交通事故预防	0.12	0.09	0.93
I7	减少葵青区的噪音污染	0.65	-0.27	0.01

<sup>1</sup> Courtney, M. G. R., 《确定保留在 EFA 中的因子数量：使用 SPSS R-Menu v2.0 可以得出更明智的判断》，载《实用评估，研究与判断》，2013 年第 18 卷第 8 期。

<sup>2</sup> DeVellis, R.F., 《规模发展：理论与应用》，载《洛杉矶：智者》，2012 年第 109-110 页。

I9	葵青区的污水处理及水质保持	0.83	0.19	0.25
I10	减轻光线对周围居民的影响	0.86	-0.08	-0.12
I11	在处理货物时考虑 3R (减少, 重复使用, 回收)	0.78	0.20	0.11
I12	维持葵青区的空气质量	0.78	0.20	0.11
I13	码头区生态环境保护	0.74	0.18	0.09
I14	确保适当的废物处理	0.78	0.22	0.16
	特征值	4.82	2.39	1.05
	百分比差异 (%)	40.19	19.90	8.73
	累积百分比差异 (%)	40.19	60.08	68.81
	克隆巴哈系数	0.75	0.74	0.89
	平均值	4.34	4.44	4.01
	S. D. *	0.75	0.70	0.89

\* S. D. = 标准偏差。

#### 4.5 验证性因素分析 (Confirmatory Factor Analysis, CFA)

验证性因素分析 (CFA) 是结构方程模型 (SEM) 的定量数据分析模型, 它指定因素的数量, 误差项以及变量与因素之间的关系。在检验假设之前, 执行 CFA 以确保 AMOS (analyse of moment structures, 也就是对矩结构的分析) 测量表的有效性。由不同研究人员推荐的模型的大量拟合优度指标是适当和一维性的<sup>1,2</sup>。统计分析的结果在所需的六个范围内显示足够的模型拟合: 近似均方根误差 (RMSEA): 切割值 < 0.08, 均方根残差 (RMR): 切割值 < 0.05, 塔克-刘易斯指数 (TLI): 切割值  $\geq 0.9$ , 比较拟合指数 (CFI): 切割值  $\geq 0.9$ , 拟合优度 (GFI): 切割值  $\geq 0.9$  和调整后的拟合优度 (AGFI): 切割值  $\geq 0.9$ 。

如表 6 所示, 充分的模型拟合表明模型是可信的和纯化的 (拟合优度指数 (GFI) = 0.885; 调整后的拟合优度指数 (AGFI) = 0.836; 塔克-刘易斯指数 (TLI) = 0.943; 范数拟合指数 (NFI) = 0.954; 均方根-均方差 (RMR) = 0.052; 均方根-均方根近似值 (RMSEA) = 0.072)。

表 6 拟合优度指标

指标	标准	结果
GFI	> 0.9	0.885
AGFI	> 0.9	0.836
TLI	> 0.9	0.943
CFI	> 0.9	0.954

<sup>1</sup> Bagozzi, R.P. 和 Yi, Y., 《关于结构方程模型的评估》, 载《市场科学研究》, 1988 年第 16 卷第 1 期, 第 74-93 页。

<sup>2</sup> Kline, R., 《结构方程模型的原理和实践》, 纽约: 吉尔福德出版社 1998 年版。



RMR	< 0.05	0.052
RMSEA	< 0.08	0.072

通过检查每个构建体上的重要因素负载来找到收敛效率。收敛有效性通过等于 AMOS 中的临界比率 (CR) 的 t 值进行检验。如果 t 值大于 -1.96 或小于 1.96, 则接受其统计意义。由于临界比率在 0.05 的水平上具有显著性, 因此可以确认所有指标测得的结构均相同, 并为每个结构的一维性和收敛性提供了有益的证明。通过比较平均方差提取 (AVE) 与每个构建体之间的平方相关性来分析判别效率。如果指标在其自身构造上的共同差异, 大于在构造上与其他构造的差异, 则表明出现了判别效率。根据表 7, 已知最高的平方相关性低于所有构建体的 AVE 的平方根。因此, 可以确定判别有效性。

表 7. 参数估计, 标准误差, 临界比和 R2

因素和比例项	非标准化因素载荷	完全标准化的因素载荷	标准误差 (SE)	临界比 (CR)	R2
经济问题					
P1	1.328	0.753	0.225	5.894	0.568
P2	1.377	0.867	0.198	6.965	0.751
P3	1.000	0.591	--	--	0.349
社会问题					
P4	1.000	0.893	--	--	0.798
P5	1.087	1.015	0.062	17.420	1.031
环境问题					
P7	1.000	0.712	--	--	0.506
P9	1.057	0.788	0.114	9.232	0.621
P10	1.106	0.810	0.116	9.563	0.656
P11	0.722	0.571	0.109	6.626	0.326
P12	1.196	0.851	0.121	9.907	0.725
P13	1.105	0.887	0.108	10.235	0.787
P14	1.325	0.902	0.128	10.321	0.814
保留					
L1	1.000	0.861	--	--	0.742
L2	0.732	0.577	0.126	5.862	0.333
L3	0.954	0.703	0.134	7.165	0.494

对复合可靠性(CR)进行了研究,以评估其可靠性和内部一致性(Awang, 2016)。综合可靠性的计算公式为:

$$(\text{标准载荷之和})^2 / [(\text{标准载荷之和})^2 + (\text{指示器测量误差之和})]$$

其中指示器测量误差为  $1 - (\text{标准载荷})^2$

CR 要求最低水平为 0.6。如表 8 所示, 环境可持续性, 经济可持续性和社会可持续性的 CR 值分别为 0.814、0.786 和 0.955, 这意味着所有 CR 都高于要求的水

平。

计算出提取的平均方差 (AVE)，以测量因一个因素而捕获的方差量与由于测量误差引起的方差量之间的关系。它的计算方式是：

**(标准负载的平方和) / [标准负载的平方和+(指标测量误差的总和)]**

其中指标测量误差为  $1 - (\text{标准负载})^2$

AVE 最低要求为 0.5。如表 8 所示，环境可持续性，经济可持续性和社会可持续性的 AVE 值分别为 0.595、0.556 和 0.914，这意味着所有 AVE 都已达到要求的水平。

**表 8 综合可靠性和平均方差提取值**

因素	综合可靠性	平均方差提取
经济	0.786	0.556
社会	0.955	0.914
环境	0.814	0.595

#### 4.6 结构方程建模 (SEM)

结构方程建模是因素分析和多元回归分析的结合。它可以分析测得的变量之间的关系，并用因素之间的路径系数表示。<sup>1</sup>

在本节中，使用 SEM 来检查环境可持续性，社会可持续性，经济可持续性和保留之间的关系。如图 2 所示，数据有效地支持了预估模型。所有关系的预期都很明显。环境可持续性绩效与保留之间的关系是显著的（估计值= 0.38，CR = 5.11），与保留相关的经济可持续性绩效也具有显著的关系（估计= 0.61，CR = 3.58），而社会可持续性和保留之间的关系则不显著。与其他两个可持续发展绩效相比，具有显著性（估计=-0.02，CR =-0.38）。

<sup>1</sup> Hox, J.J., Bechger, T.M., 《结构方程模型介绍》，载《家庭科学评论》，1998 年第 11 期，第 354-373 页

图 2 SEM 结果

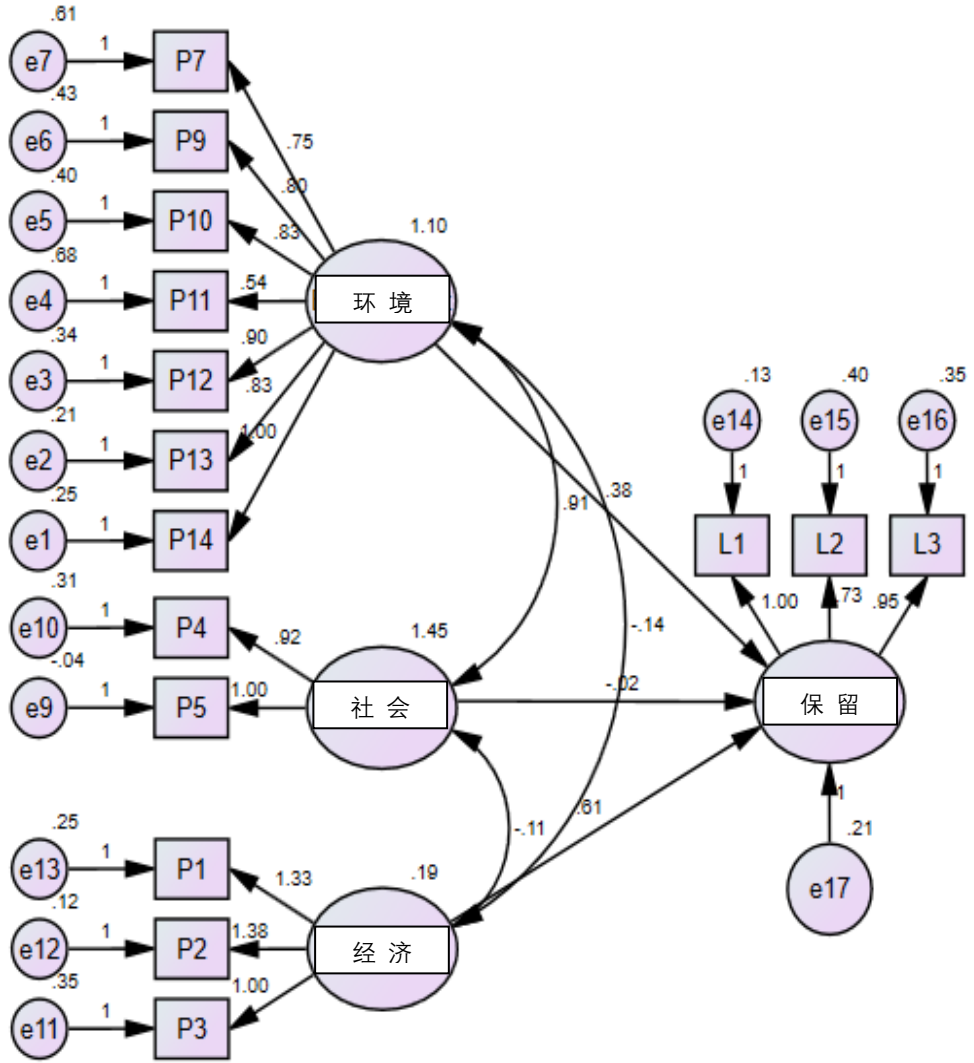

#### 4.7 港口工人，航运公司员工和附近居民在可持续性评估标准的重要性和绩效方面的差异

对不同类型的受访者（港口工人，航运公司员工和附近居民）之间的意见差异进行了调查（见表 9）。在重要性方面，受访者认为社会可持续性（平均值=4.44）是最一致的因素，其次是经济可持续性（平均值=4.34）和环境可持续性（平均值=4.01）。就绩效而言，经济可持续性评估标准在受访者中表现最佳（平均值=4.00），其次是社会可持续性（平均值=3.26），而环境可持续性则是最差的绩效（平均值

=2.82) (见表 10)。所有标准在重要性和绩效方面的 P 值均小于 0.05, 这意味着三种类型的受访者之间的回答差异显著。

#### 4.7.1 附近居民的观点

附近有 50 位居民回答了问卷。在重要性方面, 环境标准的平均得分最高, 范围为 4.26 至 4.38, 其次是社会标准, 平均得分为 4.16, 经济标准的平均得分为 4.09。从附近居民的角度来看, “在处理货物时考虑 3R (减少, 再利用, 再循环)” 是最重要的标准。在绩效方面, 就附近居民而言, 平均得分为 3.66 的社会标准表现最佳, 其次是平均得分为 3.57 的经济标准。但是, 具有最高重要性的环境标准的平均性能最低, 范围为 2.78 至 3.08。“确保安全有效地处理货物” 和 “预防港口交通事故” 的平均得分为 3.68, 是表现最佳的标准。

#### 4.7.2 货运公司员工的观点

共有 44 名员工 (包括办公室工作人员和机组人员) 均已回答问卷。关于重要性, 在航运公司受访者中, 经济和社会可持续性的平均值分别为 4.77 和 4.75。环境可持续性的重要性较低, 平均值为 4.32。在运输公司看来, “确保安全有效地处理货物” 的平均值为 4.91, 被认为是最重要的标准。在绩效方面, 经济和社会可持续性评估标准中的绩效均采用 3.98 的相同方法; 航运公司受访者认为, 环境可持续性评估标准中的绩效相对较低, 平均值为 3.39。“确保安全有效地处理货物” 的最佳绩效标准, 平均值为 4.02。

表 9 附近居民, 运输公司员工和港口工人之间的重要性差异

序号	可持续性标准的重要性	附近居民		航运公司		港口工人		F 值	P 值	多重比较
		均值	标准偏差	均值	标准偏差	均值	标准偏差			
I1	促进经济活动	4.08	0.53	4.57	0.63	4.14	0.99	5.84	0.00	(1, 2) (2, 3)
I2	确保安全有效地处理货物	4.16	0.51	4.91	0.29	4.20	0.97	18.41	0.00	(1, 2) (2, 3)
I3	提供就业机会	4.04	0.53	4.82	0.45	4.34	0.90	16.35	0.00	(1, 2) (2, 3)
I4	员工工作的保障与安全	4.18	0.48	4.75	0.44	4.50	0.89	9.33	0.00	(1, 2) (1, 3)
I5	码头交通事故预防	4.14	0.54	4.75	0.44	4.42	0.95	9.24	0.00	(1, 2)
I7	减少葵青区的噪音污染	4.28	0.61	3.64	0.78	3.02	0.96	31.36	0.00	(1, 2) (1, 3) (2, 3)
I9	葵青区的污水处理及水质维持	4.36	0.63	4.64	0.49	3.22	0.93	53.04	0.00	(1, 3) (2, 3)
I10	减轻附近居民的光线影响	4.32	0.51	3.84	0.61	3.14	0.87	38.29	0.00	(1, 2) (1, 3) (2, 3)
I11	处理货物时考虑 3R (减少, 重复使用, 回收)	4.38	0.57	4.41	0.64	3.76	1.15	9.40	0.00	(1, 3) (2, 3)
I12	维持葵青区的空气质量	4.36	0.56	4.68	0.47	3.62	0.86	32.81	0.00	(1, 3) (2, 3)
I13	码头区的生态环境保护	4.26	0.63	4.43	0.70	3.54	0.91	18.84	0.00	(1, 2) (1, 3) (2, 3)
I14	确保适当的废物处理	4.34	0.52	4.64	0.49	3.52	0.97	32.34	0.00	(1, 2) (1, 3) (2, 3)

表 10 附近居民, 船公司员工和港口工人之间的绩效差异

编号	标准	附近居民			航运公司			港口工人		
		均值	标准偏差	均值	标准偏差	均值	标准偏差	F 值	P 值	多重比较
P1	促进经济活动	3.40	0.50	3.82	0.58	4.48	0.83	28.24	0.00	(1,2)(1,3)(2,3)
P2	确保安全有效地处理货物	3.68	0.55	4.20	0.63	4.58	0.58	29.86	0.00	(1,2)(1,3)(2,3)
P3	提供就业机会	3.62	0.49	3.91	0.64	4.38	0.83	16.39	0.00	(1,3)(2,3)
P4	员工工作的保障与安全	3.64	0.56	3.95	0.53	2.28	1.55	37.05	0.00	(1,3)(2,3)
P5	码头交通事故预防	3.68	0.47	4.00	0.53	2.16	1.33	60.08	0.00	(1,3)(2,3)
P7	减少葵青区的噪音污染	2.88	0.87	3.43	0.55	2.24	1.39	16.25	0.00	(1,2)(1,3)(2,3)
P9	葵青区的污水处理及水质维持	2.94	0.71	3.61	0.54	2.38	1.35	19.77	0.00	(1,2)(1,3)(2,3)
P10	减轻附近居民的光线影响	3.08	0.88	3.36	0.49	2.10	1.27	23.60	0.00	(1,3)(2,3)
P11	处理货物时考虑 3R (减少, 重复使用, 回收)	2.78	0.65	2.52	0.55	1.76	1.30	16.90	0.00	(1,3)(2,3)
P12	维持葵青区的空气质量	2.92	0.85	3.64	0.49	2.34	1.38	19.95	0.00	(1,2)(1,3)(2,3)
P13	码头区的生态环境保护	3.06	0.65	3.41	0.50	2.26	1.24	21.82	0.00	(1,3)(2,3)
P14	确保适当的废物处理	3.02	0.99	3.73	0.69	2.14	0.45	30.95	0.00	(1,2)(1,3)(2,3)

### 4.7.3 港口工人受访者的观点

50名港口工人对问卷进行了答复。关于重要性,在港口工人受访者中,社会标准和经济标准分别为4.46和4.23,重要性较高;环境可持续性的重要性较低,平均值为3.40。在港口工人看来,平均为4.50的“员工工作安全性”被认为是最重要的标准。在绩效方面,就港口工人而言,经济可持续性的平均值为4.48,表现最佳。平均数为2.22和2.17的社会和环境可持续性标准的绩效较弱。“确保安全有效地处理货物”的平均值为4.58,是表现最佳的标准。

### 讨论与结论

由于港口是全球供应网络中的主要节点之一,因此,海运货物的数量和水运贸易的数量逐渐增长。假设人类经济发展的加速大于自然资源的恢复速度,从长远来看,它将对地球构成破坏性影响。因此,港口经营者有义务在利润最大化,社会关注和环境之间保持平衡,这被称为“可持续性”。鉴于可持续性是一个复杂的问题,有必要将其分解为较小规模的指标以进行测量和评估。

我们的研究目的是确定各种关键的可持续性标准,及其对利益相关者在香港集装箱码头的保留的影响。这项研究的主要发现是通过在葵青货柜码头和葵青区进行的问卷调查得出的,现总结如下。

在这项研究中,调查问卷最初是根据不同可持续性标准的重要性和绩效,从受访者的角度来评估协议/满意度的水平。随后,因素分析已被减少,重新排列并将变量测试做为关键因素。此外,在AMOS建立了结构方程模型(SEM)的意义是,检验该标准的重要性。

数据收集是通过对144位受访者进行的问卷调查构成的,其中包括44位船运公司的员工,葵青集装箱码头的50位雇主和50位居住在葵青区的居民。从过去许多的学者研究中,总共选择了14条相关的可持续性评估标准。据透露,我们的受访者将诸如“预防港口交通事故”之类的社会维度视为最重要的可持续性维度,可以概括为港口的劳工权利和平等;紧随其后的是经济方面,包括“确保安全有效地处理货物”等标准;经济方面则涉及利润最大化和运营效率。最后,与环境政策有关的环境维度,例如“保持葵青区的空气质量”,被认为是这三个维度中最不重要的维度。

在绩效方面,经济方面的绩效排名最高,其次是社会方面,再次是环境方面。根据信息—绩效矩阵,将14个可持续性标准分别分为三个象限。象限I“保持良好的工作”属于五个可持续性标准。关于第一象限中的指标,建议着重于重新制定劳动安全政策以及提供福利和津贴。象限II“集中于此”有五个可持续性标准。关于象限2中的标准,强烈建议在此领域进行投资。此外,有四个可持续性标准属于象限III“较低优先级”。关于象限III中的标准,建议采取更具成本效益的措施来解决这些问题。由于象限III的优先级较高,因此分配给象限III的资源相对较少。

基于确认性因素分析(CFA),已知SEM指标符合所有标准要求,从而确定了进

行 AMOS 模型分析的三维有效性。此外，借助于 AMOS 的使用，发现所有三个维度之间的所有关系都如预期的那样重要。话虽如此，却发现环境维度和经济维度与保留之间有着显著的关系，而社会维度与保留方面之间却没有有什么关系。

在航运公司的员工，居民和港口工人之间的差异中，必须解决并承认三种类型的受访者的回答差异。这是因为所有可持续性标准在重要性和绩效方面的 P 值均小于 0.05。

在研究中讨论了从可持续性标准评估结果中获得的理论和实践意义。尽管研究人员进行了大量的可持续性评估研究，但从利益相关者的角度来看，香港港口的可持续性标准评估仍然缺乏。本研究促进了可持续性指标的发展，并强调了未来调查的重要标准。此外，本研究可以作为港口运营中可持续性政策制定的基础，以进行更精确的监管。

本研究做出了重要贡献。从实践的角度来看，找出当前运营的优势和劣势将对可预见的未来业务决策产生重大影响。为了成功实施可持续发展政策，有必要突出这些薄弱环节并集中精力改进这些领域。另一项贡献是启发董事会，以有力的科学依据提高对环保的认识。由于这项研究评估了葵青货柜码头的实际情况，并包括许多利益相关者，它利用实际数据和事实来反映和呈现现实，因此，可以公平地说该研究做出了重要的实际贡献。

本文也做出了重要的理论贡献。首先，它加深了对可持续发展绩效的理解。研究发现，关于可持续发展中特定维度的绩效的学术论文并不多。然而，很多论文都将“可持续性”的概念作为讨论的主题。我们的研究可以作为进一步研究香港不同主要港口的码头运营管理的指南。这很重要，因为它通过展示不同版本的分析模型和数据收集方法，为未来的研究人员提供了不同的观点和有用的给料。因此，可以判断从理论角度已经做出了创造性贡献。

提出以下具体建议和意见，以供港口运营商参考。对于港口运营商而言，至关重要的是要在其可持续性政策中纳入外部消费者和运输公司等供应链合作伙伴的利益，以提高可持续性绩效。因此，实施可持续性实践可以减少摩擦，使运营有效地进行。其次，建议港口经营者鼓励员工之间透明有效的沟通，使员工参与可持续发展政策。与员工的紧密合作可以使公司针对可持续发展目标和法规进行更好的设计，并更好地参与实施新政策的培训计划。内部可持续性实践以及与外部组织在可持续性行动方面的合作与可持续性绩效的积极变化有着积极的联系。因此，必须在集装箱码头内引入适当的可持续性实践。

在第一象限：高重要性和高绩效中，该象限有五个主要标准：员工的工作安全和保障，港口交通事故的预防，确保安全有效地搬运货物，提供就业机会并促进经济活动。根据居民，港口工人和航运公司填写的调查表，在葵青货柜码头选择这五个主要标准是正确且必不可少的。只要它们在港口可持续发展中持续有效，就会不断有提议来完善这五个标准，以实现港口可持续性的改善。为了员工的工作安全，可以启动“工作安全行为计划”。为了增强工人的健康意识，该计划将由一群安全观察员从职业安全与健康委员会接受培训，然后前往不同的船运公司观察并识别任



何不当的工作行为。提供建议并鼓励操作员在操作之前进行伸展运动，以增加灵活性，活动关节并放松肌肉。这样可以降低操作过程中受伤的风险，例如为了预防港口交通事故，可以推出“安全驾驶比赛”，以提高员工对安全驾驶行为的认识。为了提高认知并为驾驶员配备预防事故的技术，可以与货柜码头合作，与香港警务处进行针对安全的驾驶谈话。在这种情况下，将对驾驶员进行“驾驶中的危险感知和安全驾驶行为”的培训，以消除集装箱港口发生事故的风险。为了确保安全有效地处理货物并促进经济活动，增加周转率可以提高码头运营的自动化程度，更快、更安全地改善码头装卸货物，从而促进经济活动。调试带有全自动泊位的“自动船”，并配备船对岸起重机、与自动导引车（AGV）相关的堆垛起重机，可以提高货物装卸效率和安全性，提高周转率，从而促进经济活动。为了提供就业机会，集装箱港口可以促进工作并为员工提供津贴。由于葵青货柜码头离市区和港铁站很远，只有小巴和的士才能进入码头区，人们很难开始这份工作，因此，以更高的津贴来促进工作很重要，因为有员工就可以吸引更多人们在集装箱来港口找到工作。

在第二象限：高重要性和低绩效中，该象限有五个主要标准：在葵青区处理废水和保持水质，在处理货物时考虑3R（减少，再利用，再循环），在葵青保持空气质量区，港口区的生态环境保护和适当的废物处理保证。根据居民，港口工人和航运公司填写的调查表，这五个主要标准是必不可少的，但在葵青货柜码头表现不佳。相应地，本文对这些准则提出了一些建议。为处置葵青区的污水和维持水质，建议港口经营者可在海港区治理计划中与公共部门合作。借助该计划，港口运营商可以不时检查水质并确定水污染的主要来源。这样，港口运营商可以对其运营活动进行适当的调整，以减少对环境的影响。为了维持葵青区的空气质量，建议投资改善港口设施。例如，安装最先进的过滤技术以改善空气质量。高效的空气过滤可以帮助港口更好地控制其污染物排放，并为第一线的港口工人提供更好的工作环境，通过先进的过滤系统创造双赢局面。对于生态环境保护，港口经营者要承担多少责任仍然是未知的。因此，强烈建议港口经营者与环保组织进行磋商。环保组织将为生态环境保护提供不同的专业建议，以使港口附近的生物多样性保持稳定。为了在处理货物时考虑3R（减少，再利用，再循环）并确保适当的废物处置，建议公司实施新的废物处置政策。员工在处理废弃物时有不同的安排和要求，港口运营中应有自我监控政策，以确保以适当的方式处理废物。另外，定期进行培训和教育。对港口工人进行适当的处置措施教育，以提高环保意识并阐明废物处置程序也很重要。

对于重要性低，绩效低的标准，它们在开发计划中的优先级较低。由于优先级较低，分配给这些标准的资源将更少。因此，应采取成本更低的措施。为了减少葵青区的噪音污染并减轻对邻近居民的光线影响，港口经营者可以与葵青区的物业公司合作，在装修公寓时使用隔音材料和厚窗帘，以减少光污染和噪音污染。为了提高集装箱码头的景观并提供公平的工作机会，港口经营者应监督和控制外包劳务供应商的行为，确保维护干净整洁的码头区域的服务质量以及公平的雇用过程。

尽管本文从理论和实践意义上做出了宝贵的贡献，但这项研究仍存在许多局限性。首先，研究范围限于时间和资金限制。由于该项目的期限为一年，因此需要根

据研究北京缩小焦点小组的范围。因此，研究涉及三种类型的参与者，而港口运营的可持续性中仍应包含许多利益相关者的意见。此外，样本量相对较小，我们的调查表中有 144 位受访者。由于被调查者的数量可能不足以代表整个利益相关者，因此问卷的权威性和代表性可能会受到质疑和怀疑。此外，从受访者那里收集的数据是他们对可持续发展绩效的主观意见，被调查者很可能不愿如实表达他们的意向和避免对被调查者本身造成不必要的冲击，调查结果可能不完全真实，因此建议采用更客观的措施来提高信息准确性。

为了评估香港港口运营的可持续性，有必要扩大研究规模。可以延长研究时间，进行纵向研究以评估可持续性。此外，研究应让更多的利益相关者参与，以提高调查的有效性。

译者：张红宽，陶岷

\*\*\*

# Assessing Port Sustainability Criteria and Stakeholder's Retention in Hong Kong

LU Chin-Shan\* KWONG Kwan Yu\*\* LO Kam Wai\*\* SHUM Mei Ying\*\*

**Abstract:** The purpose of this study is to assess crucial sustainability and its impact on stakeholders in the context of container port in Hong Kong. Data collection was based on a questionnaire survey from 144 respondents from nearby residents, shipping company employees and container terminal workers. An exploratory factor analysis and confirmatory factor analysis were conducted to identify crucial sustainability criteria of container port. In addition, a structural equation modeling was applied to examine the relationships between sustainability dimensions such as environment sustainability, social sustainability, economic sustainability and stakeholder retention. Results indicated that social aspects with respect to “employee job security and safety” and “terminal traffic accidents prevention” were ranked as the most important sustainability criteria, followed by economic aspects of “ensuring cargo handled safely and effectively”, “offering employment opportunities” and “facilitation of economic activities”. Results also showed that environmental and economic dimensions had a significant impact on stakeholder retention. Practical implications for port sustainability practices were discussed in this study.

**Keywords:** Port Sustainability Stakeholder Retention

## I. Introduction

With rapid development of international trade, the growth rate of world container throughput increased by 2.6% and reached 152 million TEUs in 2018.<sup>1</sup> A container port serves as a vital role in the supply chain networking and provides a major connection between the sea transport and in-land transport. However, the massive demand reflecting in the increase of the volume of container cargo raises concern about the negative impact on environment, safety and human health. Port authorities, therefore, need to take sustainability as one of their organizational goals, maintaining a balance between environment, social and economic issues. Recently, port sustainability has paid increasing

---

\*LU Chin-Shan is currently a Professor and Associate Head at the Department of Logistics and Maritime Studies of the Hong Kong Polytechnic University and a Director of the C.Y Tung International Center for Maritime Studies, E-mail:chin-shan.lu@polyu.edu.hk

\*\*KWONG Kwan Yu, LO Kam Wai and SHUM Mei Ying are currently students at the Department of Logistics and Maritime Studies of the Hong Kong Polytechnic University.

©THE AUTHOR AND MARINE LAW AND POLICY

<sup>1</sup> United Nations Conference on Trade and Development (UNCTAD). Review of Maritime Transport 2019. United Nations Publication: New York and Geneva (2019).

attention to port organizations<sup>1</sup> and extant port studies.<sup>2</sup> Most extant studies examined sustainability at seaports from port authorities' or carriers' point of view, however, nearby port residents' opinions have rarely been discussed in previous literature. To the best of our knowledge, the impact of port sustainability on stakeholder retention have not been examined and validated in the context of port sustainability research.

Thus, this research aims to identify crucial sustainability criteria and its impact on stakeholder retention at container port in Hong Kong. The Kwai Tsing is the major container port, located along Rambler Channel between Tsing Yi Island and Kwai Chung, Hong Kong. It covers an area of 279 hectares with a total quay depth of 7684 meters. There are 24 container berths, providing for an approximated 18.3 million TEUs in 2019.<sup>3</sup> However, activities of Kwai Tsing Container Terminal are causing severe air pollution. The annual average of nitrogen dioxide of Kwai Chung area is 54 micrograms per cubic meter in 2019, which is higher than the annual limit value (40 micrograms) of Hong Kong.<sup>4</sup> In 2017, the emissions of SO<sub>2</sub>, NO<sub>x</sub>, RSP and FSP from marine vessels accounted for 52%, 37%, 34% and 41% of the total emissions, respectively. In 2019, there were 459 cases of accidents within and outside Hong Kong waters, whereas 9 persons were killed and 31 persons missing, respectively.<sup>13</sup> This reflects the need for port authorities in Hong Kong to face and address the issue of sustainability.

There are five sections in this paper. After the introduction, follows the review of literature and previous researches. The background of the study, deals with the selection of a number of sustainability criteria that will be factored in the research. The research

---

<sup>1</sup> International Association of Ports and Harbors (IAPH), IAPH 2018-2019 Annual Report (2020). Retrieved from [http://www.iaphworldports.org/iaph/wp-content/uploads//publications/Annual\\_Report\\_2018-2019.pdf](http://www.iaphworldports.org/iaph/wp-content/uploads//publications/Annual_Report_2018-2019.pdf) Maritime and Port Authority of Singapore (MPA), Maritime Sustainability Reporting Guide, Best Practices for Creating A Maritime Sustainability Report, Vol. 01 (2019). Retrieved from [https://api2.sgx.com/sites/default/files/2019-09/MPA\\_Sustainability\\_Guidebook.PDF](https://api2.sgx.com/sites/default/files/2019-09/MPA_Sustainability_Guidebook.PDF). The Port of Los Angeles, Port of Los Angeles Inventory of Air Emissions-2018 (2019). Retrieved from [https://kentico.portoflosangeles.org/getmedia/0e10199c-173e-4c70-9d1d-c87b9f3738b1/2018\\_Air\\_Emissions\\_Inventory](https://kentico.portoflosangeles.org/getmedia/0e10199c-173e-4c70-9d1d-c87b9f3738b1/2018_Air_Emissions_Inventory).

<sup>2</sup> Acciaro, M., Corporate responsibility and value creation in the port sector, *International Journal of Logistics Research and Applications*, 18 (3), 291–311 (2015). Ashrafi, M., Acciaro, M., Walker, T. R., Magnan, G. M., and Adams, M., Corporate sustainability in Canadian and US maritime ports, *Journal of Cleaner Production*, 220, 386-397 (2019). Darbra, R. M., T. Pittam, K. A. Royston, J. P. Darbra, and H. Jornee, Survey on environmental monitoring requirements of European ports, *Journal of Environmental Management* 90 (3), 1396–1403 (2009). Lim, S., Pettit, S., Abouarghoub, W. and Beresford, A. Port sustainability and performance: A systematic literature review, *Transportation Research Part D: Transport and Environment*, 72, 47-64 (2019). Lu, C. S., Shang, K. C. and Lin, C. C., Identifying crucial sustainability assessment criteria for container seaports. *Maritime Business Review*, 2(1), 90-106 (2016). Oh, H., Lee, S.W. and Seo, Y. J., The evaluation of seaport sustainability: The case of South Korea, *Ocean and Coastal Management*, 161, 50-16 (2018). Seuring, S. and Muller, M., From a literature review to a conceptual framework for sustainable supply chain management, *Journal of Cleaner Production*, 16(15), 1699-1710 (2008). Wooldridge, C. F., McMullen, C. and Howe, V. 1999. Environmental management of ports and harbours—Implementation of policy through scientific monitoring." *Marine Policy* 23 (4–5): 413–425.

<sup>3</sup> Marine Department, Container Throughput of Hong Kong Port, the Government of the Hong Kong Special Administrative Region (2020). Retrieved from <https://www.mardep.gov.hk/en/publication/portstat.html#5>.

<sup>4</sup> Environmental Protection Department, Air Quality in Hong Kong 2019: Data & Air Pollutant Emission Inventory, The Government of the Hong Kong Special Administrative Region (2020). Retrieved from [https://www.epd.gov.hk/epd/english/environmentinhk/air/data/emission\\_inve.html#emission\\_trends](https://www.epd.gov.hk/epd/english/environmentinhk/air/data/emission_inve.html#emission_trends)

methodology section will discuss the main data collection method that will be employed to obtain the relevant information needed to conduct the analysis. The results section provides the result and interpretation of factor analysis and structural equation modeling. The discussion and conclusions for sustainability policy suggestions are explored in the final section.

## **II. Literature Review**

### ***A. Definition of Sustainability***

Sustainability concerns meeting the needs of the present without compromising the ability of future generations to also meet their needs. There are three pillars with regard to the concept of sustainability: environment, social and economic. Port sustainability is port business activities protect and sustain human and natural resources that meets ports and the stakeholders present and future needs.<sup>1</sup> Container port sustainability is critically germane for three main reasons which are social sustainability, economic sustainability and environment sustainability - related to container port operations.<sup>2</sup>

### ***B. Sustainability Assessment Criteria***

A number of international organizations have different principles on sustainable development (e.g., The UN Global Compact, OECD etc.) Sustainability assessment criteria have been developed by different international ports. ISO (International Standard Organization) evaluated sustainable development includes environmental regulation and policy as well as self-evaluation management mechanism system (ISO website). However, the opinions from local residents and carriers were not considered in the study. There are several aspects to measure social sustainability such as human rights, employee and workplace security and safety, social development etc.<sup>3</sup> Therefore, the sustainability assessment consists of social sustainability, economic sustainability and environmental sustainability.

Social dimension, economic dimension and environmental dimension were interrelated in sustainable development as long as most of the previous researches only focused on the environmental dimension, included quality of air, emission of green gas, emission of CO<sub>2</sub>, recycling and waste, lightning mitigation, noise pollution, quality of water etc. Meanwhile, economic dimension consists of sustainable assessment criteria, for example local economic activities development, employment development, fair competition etc. For the social dimension, there are several assessment items included- port accessibility, employee safety and security, port partners communication etc. Shiau and Chuang (2015) pointed out 34 port sustainability assessment criteria indicators selected by local residents and legislators.<sup>4</sup> Hence, a total of 14 sustainability assessment criteria indicators were adapted from previous studies which included environmental dimension, social dimension and economic dimension, used in this study.

---

<sup>1</sup> Gul, D.S. and Cimen, K.C., Port sustainability and stakeholder management in supply chains: a framework on resource dependence theory, *The Asian Journal of Shipping and Logistics*, 28, 301-320 (2012).

<sup>2</sup> Yap, W.Y. and Lam, J.S.L., 80 million-twenty-foot-equivalent-unit container port? Sustainability issues in port and coastal development, *Ocean & Coastal Management*, 71(2), 13-25 (2013).

<sup>3</sup> McIntosh, M., Thomas, R., Leipziger, D. and Coleman, G., *Living Corporate Citizenship – Strategic Routes to Socially Responsible Business*, Prentice Hall, London (2003).

<sup>4</sup> Shiau, T.A. and Chuang, C.C., Social construction of port sustainability indicators: a case study of Keelung Port, *Maritime Policy and Management*, 42(1), 26-42 (2015).

### **III. Methodology**

This study aims to investigate and identify the crucial sustainability criteria of the Kwai Tsing Container Terminal through examining the importance of the sustainability criteria and assessing the current performance of the terminal by port workers, shipping company workers and residents. It was done by conducting a questionnaire survey, followed by personal interviews with the shipping company managers.

#### ***A. Questionnaire Design and Determination of Measures***

The sustainability assessment criteria were selected from sustainability reports and researches. The questionnaire surveys were designed and issued to port workers, shipping company and residents. For the questionnaire design, the general information was first specified and the issues were listed- type of questionnaires, contents of individual questions, form of response. In order to be clearer, the wordings of the questionnaire, sequence of the questions and the characteristics of the sustainability criteria will be precise and orderly arranged in the questionnaire.

Moreover, the questionnaire content validity was checked by literature review and interviews with several port experts and academics. The questionnaire was translated into Chinese for the port workers, shipping company and residents in order to ensure the meaning remains the same as the original English questionnaire. The interview resulted in some minor modifications in the assessment criteria wordings and they were accepted after amending the sustainability criteria. A five-point rating scale was used for each factors- 1 = very unimportant, 2 = unimportant, 3 = neither agree nor disagree, 4 = important and 5 = very important to identify and rank the importance of sustainability assessment criteria according to port workers, shipping company and residents standpoint. The SPSS 25.0 software was used for statistics analyses.

#### ***B. Research Sample***

In this study, the sample of the research was focused on residents, port workers, shipping company workers and managers who are important indicators in the identification and determination of the sustainability assessment criteria as they live around the ports and participate in front line port activities.

A total of 150 questionnaire surveys were done in Google Form and delivered in March 2019. The surveys received a total of 50 each for residents and shipping company workers and 44 for port workers. Ultimately the total usable responses were 144 out 150.

Man-on-the-street interview was carried out for the port workers and resident's questionnaire interviews. The Google Form questionnaire was showed on the tablet and iPad and invited residents who live in Tsing Yi and Lai King as well as port workers who work in the Kwai Tsing Container Terminal completed the questionnaire. The questionnaire was illustrated and a total of 100 street interviews with 50 residents and 50 port workers were done in the afternoon of 19 March, 2019.

#### ***C. Research Methods***

There are numerous researches adapted in this study. Descriptive statistics and exploratory factor analysis are used to categorize a great deal of sustainability attributes

into a concrete set of underlying factors and dimensions.<sup>1</sup> Furthermore, our research carries out a reliability test to evaluate whether these dimensions are reasonable. In addition, Confirmatory Factor Analysis (CFA) was adapted to verify measurement models. The involvement of structural equation modelling software AMOS helps to analyze the measurement models, review psychometric properties and extinguish the relationship between the latent variable and the proposed measures. Eventually, one-way analysis of variance (ANOVA) is also adapted to figure out the diversity existing between the port workers, shipping companies and residents in the level of significance of the sustainability criteria.

From the AMOS software, the model can show the relationship between the factors and retention for residents, shipping company and port operators. The retention for the Kwai Tsing Container Terminal is important for those three stakeholders. There are three questions designated for finding out the tendency of residents continuously living in Kwai Tsing District. There are “To what extent, I feel satisfied with the living environment of Kwai Tsing District / working environment of Kwai Tsing District/the service offered by Kwai Tsing container terminals” , “To what extent, I have no plan of leaving Kwai Tsing District / quitting the job at Kwai Tsing container terminals/using other port services located in different location.” and “ To what extent, I recommend people to live in Kwai Tsing District / work in Kwai Tsing container terminals / use the service in Kwai Tsing container terminals.” respectively. The above questions are aimed to evaluate the retention of Kwai Tsing container terminals with different stakeholders. For the viewpoint of residents, the level of desirability to stay in Kwai Tsing District represents the level of retention towards Kwai Tsing container terminals. For the viewpoint of shipping companies, the willingness of continuously consuming the services provided by Kwai Tsing container terminals represents the level of retention towards Kwai Tsing container terminals. From the viewpoint of port workers, the level of willingness to work in Kwai Tsing container terminal in the long term stands for the level of retention towards Kwai Tsing container terminals.

#### **IV. Results**

##### ***A. Respondents' Profile***

As shown in Table 1, the profile of respondents shows a vast majority of the respondents are residents and port workers (50 % each) followed by 44 % shipping company workers. As long as this study attempted to identify and evaluate the sustainability criteria in the environment, social and economic aspects, the three main types of respondents play an important role by introducing their opinions.

In this statistics, majority of respondents- with 38 per cent of residents, port workers and shipping company workers aged 30 – 49 years old followed by 33 per cent residents, port workers and shipping company workers aged 18-29 years old, whereas 23 per cent aged

---

<sup>1</sup> Hair, J.F., Black, W.C., Babin, B.J. and Anderson, R.E., *Multivariate Data Analysis*, 7th edition, Prentice-Hall, Upper Saddle River, New Jersey (2010).

50 – 64 years old and 3 per cent aged 65 years old or above and 17 years old or below were identified.

For tenure, the result revealed that 29 per cent of them have served in company for 5 to 9.99 years, 26 per cent served for 10 to 14.99 years, 27 per cent served for more than 15 years, whereas 15 per cent have only worked for 1 to 4.99 years and 3 per cent, for less than one year.

**Table 1 Respondents' profile (N = 144)**

Respondents' Profile		Frequency	Percentage
Type	Residents	50	35
	Shipping Company	44	30
	Port Workers	50	35
Age	17 years old or below	4	3
	18-29 years old	48	33
	30-49 years old	55	38
	50-64 years old	33	23
	65 years old or above	4	3
Tenure	Less than one year	5	3
	1-4.99 years	21	15
	5-9.99 years	42	29
	10-14.99 years	37	26
	15 years or above	39	27
Education	Junior Secondary or below	15	10
	Senior Secondary	36	25
	Diploma or Associate Degree	44	31
	Undergraduate Degree or above	49	34
Income (HKD)	Below \$10000	12	8
	\$10000-14999	15	10
	\$15000-19999	48	34
	\$20000-29999	32	22
	\$30000-49999	21	15
	\$50000 or above	16	11

For education, 34 per cent of respondents have obtained undergraduate certificates or above followed by 31 per cent of respondents having diploma or associate degree, 25 per cent graduated in senior secondary and only 10 per cent graduated from junior secondary or below.

For income, a vast majority of 34 per cent of respondents earn \$15,000 – 19,999 income a month, 22 per cent of respondents earn \$20,000 – 29,999, 15 per cent of



respondents earn \$30,000 – 49,999, 11 per cent earn \$50,000 or above, 10 per cent earn \$10,000 – 14,999 and 8 per cent earn below \$10,000.

### *B. Importance – Performance Analysis*

Importance-performance analysis (IPA) is a widely accepted method for measuring service quality, and aims at identifying which criteria have larger effect towards customer satisfaction and affect customer loyalty. In implementing IPA analysis, it is crucial to clearly determine the criteria of sustainability. In this study, there are twelve sustainability criteria chosen to investigate. Based on the predetermined criteria, two dimensions are classified: (1) the importance of each criteria and (2) judgments of its performance.

#### ***B-1 Relative importance of container terminal sustainability assessment criteria***

The level of relevance of container terminal sustainability assessment criteria has been under our analysis and ranked by the mean scores. The mean ranges from not important at all (score = 1) to very important (score = 5) which is shown in Table 2. The three criteria with highest scores are “employee job security and safety”, “Terminal traffic accidents prevention” and “Ensuring cargo handled safely and effectively” which scores over 4.4. In addition, the majority of the criteria scores more than 4.0 in general such as offering employment opportunities. On the other hand, the two criteria with the lowest score are “Enhancing terminal landscape” and “Providing a fair job opportunity” with mean of 3.33. In the light of the ranking, it is shown that all three dimensions of sustainability are highly appreciated in the view of respondents including port workers, Kwai Tsing residents and shipping companies.

#### ***B-2 Relative performance of container terminal sustainability assessment criteria***

The research investigated container terminals’ sustainability criteria performance in three sustainable aspects: economic, social and environmental aspects. Respondents are requested to provide their perception on the sustainability performance of Kwai Tsing Terminals and 14 sustainable criteria are ranked. The mean ranges from not important at all (score = 1) to very important (score = 5) which is shown in Table 3. The three criteria with highest score for its performance are “Ensuring cargo handled safely and effectively”, “Offering employment opportunities” and “Facilitating to economic activities” which scores 4.15, 3.97 and 3.87 respectively. After the integration of the data from three parties, the respondents’ perceptions ranged from 2.35 to 4.15 which indicates Kwai Tsing container terminals have mixed performance in the light of the three-dimension measured by sustainability. In contrast, respondents showed the following three sustainability indicators’ performance is the least “Decreasing noise pollution in Kwai Tsing District”, “Mitigating light influence on neighboring residents” with mean of 2.83 and “Considering 3R (reduce, reuse, recycle) when handling cargo” with a mean of 2.35.

**Table 2. Respondents' importance of port sustainability assessment criteria**

Rank	Code	Criteria	Mean	SD
------	------	----------	------	----

1	I4	Employee job security and safety.	4.47	0.68
2	I5	Terminal traffic accidents prevention.	4.42	0.73
3	I2	Ensuring cargo handled safely and effectively.	4.40	0.74
4	I3	Offering employment opportunities.	4.38	0.73
5	I1	Facilitating to economic activities.	4.25	0.77
6	I12	Maintaining air quality in Kwai Tsing District	4.20	0.79
7	I11	Considering 3R (reduce, reuse, recycle) when handling cargo.	4.17	0.89
8	I14	Ensuring proper waste disposal.	4.15	0.84
9	I13	Ecological environment protection in terminal area.	4.06	0.85
10	I9	Disposing of effluents and maintaining water quality in Kwai Tsing District.	4.05	0.94
11	I10	Mitigating light influence on neighboring residents.	3.76	0.84
12	I7	Decreasing noise pollution in Kwai Tsing District.	3.65	0.95
13	I6	Enhancing container terminal landscape.	3.33	0.88
14	I8	Providing a fair job opportunity.	3.33	0.94

**Table 3 Respondents' assessment on performance of port sustainability assessment criteria**

Rank	Code	Criteria	Mean	SD
1	P2	Ensuring cargo handled safely and effectively.	4.15	0.70
2	P3	Offering employment opportunities.	3.97	0.74
3	P1	Facilitating to economic activities.	3.87	0.77
4	P4	Employee job security and safety.	3.26	1.25
5	P5	Terminal traffic accidents prevention.	3.25	1.19
13	P6	Enhancing container terminal landscape.	3.02	0.78
6	P9	Disposing of effluents and maintaining water quality in Kwai Tsing District.	2.95	1.06
7	P12	Maintaining air quality in Kwai Tsing District.	2.94	1.12
8	P14	Ensuring proper waste disposal.	2.93	1.17
9	P13	Ecological environment protection in terminal area.	2.89	0.99
14	P8	Providing a fair job opportunity.	2.89	1.08
10	P7	Decreasing noise pollution in Kwai Tsing District.	2.83	1.12
11	P10	Mitigating light influence on neighboring residents.	2.83	1.08
12	P11	Considering 3R (reduce, reuse, recycle) when handling cargo.	2.35	1.00

#### **4.2.3 Importance and Performance Relations**

Figure 1 shows that the central tendency of each criteria's importance and performance will be paired and used as coordinates for plotting respective attribute in two-dimensional grid that has been divided into four quadrants:

Each quadrant in the matrix is divided by the mean score of importance of criteria [4.05] from high to low (in vertical axis) and the mean score of performance

of criteria [3.15] from high to low (in horizontal axis). The divergence between importance and performance are therefore clearly shown in the figure. It points out that the respondents' satisfaction on the sustainability assessment criteria by locating each criterion into appropriate quadrant according to its relative importance and performance. The location of criteria will translate different impact upon the strategic interpretation within each quadrant, four quadrants in IPA indicate four situations with different potential strategy for each quadrant. The quadrants are:

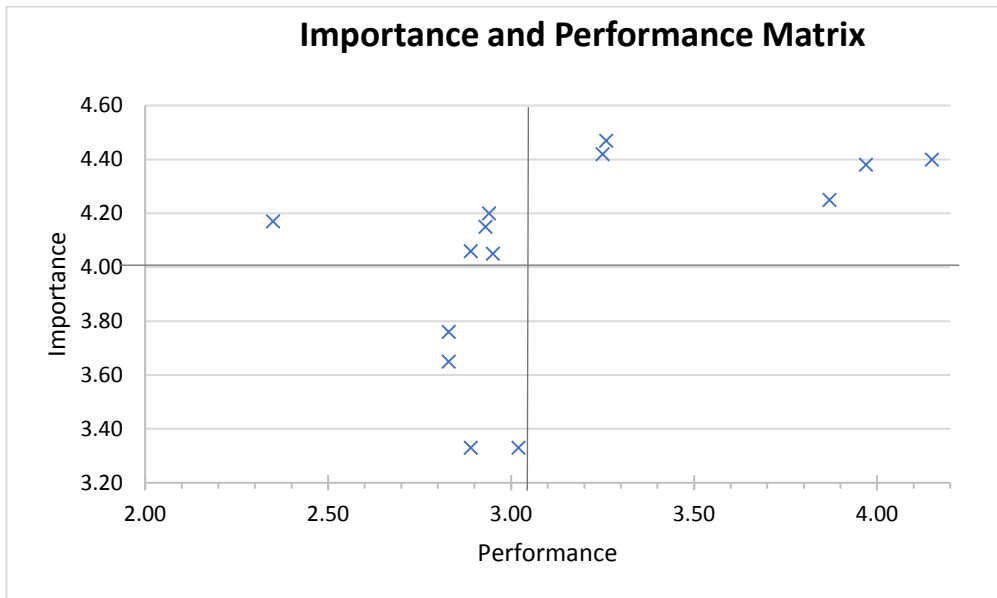

Figure 1. Importance and performance matrix of port sustainability

### I. Quadrant I: High importance and high performance

In this study, there are five criteria fall in this quadrant, showing that, both their importance and performance are above mean (4.04 for importance and 3.15 for performance). These criteria are “Employee job security and safety” which scores 4.47 and 3.26 in importance and performance respectively; “Terminal traffic accidents prevention” which scores 4.42 and 3.25; “Ensuring cargo handled safely and effectively” which 4.40 and 4.15; “Offering employment opportunities” which scores 4.38 and 3.97; and “Facilitating to economic activities” which scores 4.25 and 3.87.

### II. Quadrant II: High importance and low performance

Five criteria fall in this quadrant, showing high importance but low performance compared to the mean score. These criteria are “Maintaining air quality in Kwai Tsing District” which scores 4.20 and 2.94 in importance and performance respectively; “Considering 3R (reduce, reuse, recycle) when handling cargo” which scores 4.17 and 2.35; “Ensuring proper waste disposal” which scores 4.15 2.93; “Ecological environment protection in terminal area” which scores 4.06 and 2.89; and “Disposing of effluents and

maintaining water quality in Kwai Tsing District” which scores 4.05 and 2.95. Quadrant III: Low importance and low performance

Four criteria fall in this quadrant, representing both their importance and performance are below mean. These criteria “Mitigating light influence on neighboring residents” which scores 3.76 and 2.83 in importance and performance respectively; “Decreasing noise pollution in Kwai Tsing District” which scores 3.65 and 2.83; “Enhancing container terminal landscape” which scores 3.33 and 3.02; and “Providing a fair job opportunity” which scores 3.33 and 2.89.

III. Quadrant IV: Low importance and high performance

Criteria fall in this quadrant show low importance but high performance compared to the mean score. No criteria fall in this quadrant in this study.

#### ***4.3 Correlations between the sustainability assessment criteria***

The correlation coefficient is computed to measure the strength and direction of the linear relationship between two criteria (see Table 4). It is calculated as the covariance of the variables divided by the product of their standard deviations. The higher the value, the closer the relationship between two variables. Criteria 1 “Facilitating to economic activities”, criteria 2 “Ensuring cargo handled safely and effectively” and criteria 3 “Offering employment opportunities” are mostly interrelated, with values of 0.373 and 0.364 between criteria 1 to 2 and 1 to 3 respectively, as well as 0.787 between criteria 2 to 3. Criteria 4 “Employee job security and safety” and criteria 5 “Terminal traffic accidents prevention” are interrelated, with correlation value of 0.592, however the correlations of criteria 6 “Enhancing container terminal landscape” with criteria 4 and 5 are not significant, at -0.140 and -0.043 respectively. For criteria 7 to 14, the correlations are ranging from 0.206 to 0.695.

Table 4 Correlations between port sustainability criteria

	I1	I2	I3	I4	I5	I6	I7	I8	I9	I10	I11	I12	I13	I14
I1	1													
I2	0.373**	1												
I3	0.364**	0.787**	1											
I4	0.297**	0.570**	0.458**	1										
I5	0.235**	0.201*	0.247**	0.592**	1									
I6	0.106	0.012	0.022	-0.140	-0.043	1								
I7	0.036	-0.044	-0.086	-0.090	0.057	0.190*	1							
I8	0.012	-0.060	-0.081	-0.054	-0.030	0.116	0.421**	1						
I9	0.320**	0.332**	0.197*	0.293**	0.298**	0.108	0.497**	0.307**	1					
I10	0.016	0.042	0.011	-0.015	-0.018	0.154	0.581**	0.420**	0.619**	1				
I11	0.222**	0.233**	0.199*	0.248**	0.189*	-0.010	0.297**	0.301**	0.660**	0.649**	1			
I12	0.227**	0.326**	0.291**	0.150	0.180*	0.127	0.273**	0.166*	0.580**	0.517**	0.608**	1		
I13	0.296**	0.216**	0.120	0.193*	0.173*	0.133	0.206**	0.247**	0.663**	0.525**	0.497**	0.640**	1	
I14	0.266**	0.276**	0.296**	0.198*	0.275**	0.049	0.344**	0.266**	0.695**	0.594**	0.647**	0.585**	0.555**	1

\*\* Correlation is significant at the 0.01 level (2-tailed)

\* Correlation is significant at the 0.05 level (2-tailed)

#### 4.4 Factor analysis and reliability test

Exploratory Factor Analysis (EFA) was used for analyzing the data structure, as well as removing the latent factors from measured variables.<sup>1</sup> The sample size of this study is 144 respondents and the quantity of items is 14, which is very close to the suggested level. For Kaiser-Meyer-Olkin Measure of Sampling Adequacy (KMO), the values should be above 0.5 with a P value smaller than 0.05 in order to be regarded as significant (Pearce and Yong, 2013). The KMO in this study is 0.781 and Bartlett's Test of Sphericity was significant [ $X^2 = 991.450$ ,  $P < 0.00$ ], which is above the level required.

The minimum levels for eigenvalues and factor loadings are 1.0 and 0.5 to be regarded as significant; and the higher the factor loadings, the better the factors being explained by the measured variables (Pearce and Yong, 2013). Among the variables, two variables from two factors with factor loadings lower than 0.5 were removed from advance analysis – “I6: Enhancing container terminal landscape” and “I8: Providing a fair job opportunity (employment will not be affected by race, gender, etc.)”.

As can be seen in Table 5, results indicated that twelve remaining variables accounted for 68.81% of the total variance. Cronbach's Alpha is applied to test the reliability, to guarantee the reliability and consistency, and the index is regarded as satisfactory when above 0.7.<sup>2</sup> The index of all the three factors in this study was above 0.74, which are concerned to be acceptable. The factors are labelled and described as following:

Factor 1, environmental sustainability, containing seven criteria: “I7: Decreasing noise pollution in Kwai Tsing District”, “I9 : Disposing of effluents and maintaining water quality in Kwai Tsing District”, “I10 : Mitigating light influence on neighboring residents”, “I11 : Considering 3R (reduce, reuse, recycle) when handling cargo”, “I12 : Maintaining air quality in Kwai Tsing District”, “I13 : Ecological environment protection in terminal area”, and “I14 : Ensuring proper waste disposal”. Referring to Table 6, I10 has the highest factor loading of 0.86, among the 40.19 % of the total variance.

Factor 2, economic sustainability, containing three criteria, “I1: Facilitating to economic activities”, “I2: Ensuring cargo handled safely and effectively: and “I3: Offering employment opportunities”. Referring to Table 6, I2 has the highest factor loading of 0.89, among the 19.90 % of the total variance.

Factor 3, social sustainability, containing two criteria, “I4: Employee job security and safety” and “I5: Terminal traffic accidents prevention”. Referring to Table 6, I5 has the highest factor loading of 0.93, among 8.73 % of the total variance.

**Table 5 Factor analysis to identify factors for port sustainability criteria**

Cod e	Statements	Factor 1	Factor 2	Factor 3
I1	Facilitating to economic activities	0.19	0.54	0.19

<sup>1</sup> Courtney, M. G. R., Determining the number of factors to retain in EFA: Using the SPSS R-Menu v2.0 to make more judicious estimations. *Practical Assessment, Research and Evaluation*, 18(8) (2013).

<sup>2</sup> DeVellis, R.F., *Scale development: Theory and applications*. Los Angeles: Sage. 109–110 (2012).

I2	Ensuring cargo handled safely and effectively	0.12	0.89	0.14
I3	Offering employment opportunities	0.04	0.88	0.11
I4	Employee job security and safety	0.04	0.48	0.74
I5	Terminal traffic accidents prevention	0.12	0.09	0.93
I7	Decreasing noise pollution in Kwai Tsing District	0.65	-0.27	0.01
I9	Disposing of effluents and maintaining water quality in Kwai Tsing District	0.83	0.19	0.25
I10	Mitigating light influence on neighboring residents	0.86	-0.08	-0.12
I11	Considering 3R (reduce, reuse, recycle) when handling cargo	0.78	0.20	0.11
I12	Maintaining air quality in Kwai Tsing District	0.78	0.20	0.11
I13	Ecological environment protection in terminal area	0.74	0.18	0.09
I14	Ensuring proper waste disposal	0.78	0.22	0.16
	Eigenvalues	4.82	2.39	1.05
	Percentage variance (%)	40.19	19.90	8.73
	Accumulated percentage variance (%)	40.19	60.08	68.81
	Cronbach's Alpha	0.75	0.74	0.89
	Mean	4.34	4.44	4.01
	S.D.	0.75	0.70	0.89

Note: S.D. = standard deviation.

### 1.5 Confirmatory Factor Analysis (CFA)

The confirmatory factor analysis (CFA) is a quantitative data analysis model of structural equation modeling (SEM) which specifies the number of factors, error terms and the relationship among variables and factors. Before, testing the hypotheses, a CFA was performed to ensure the validity of measurement scales by AMOS. A number of goodness-of-fit indices recommended by the different researchers were adequate fit and unidimensionality of the model.<sup>1,2</sup> The result which meets the statistical analysis in this required six scopes shows the adequate model fit: Root mean square error of approximation (RMSEA): cut value of < 0.08, Root Mean Square Residual (RMR) : cut value of < 0.05, Tucker-Lewis Index (TLI): cut value of  $\geq 0.9$ , the comparative fit index

<sup>1</sup> Bagozzi, R.P. and Yi, Y., On the evaluation of structural equation models, *Academy of Marketing Science*, 16(1), 74-93 (1988).

<sup>2</sup> Kline, R., *Principles and Practice of Structural Equation Modeling*, The Guilford Press, New York, NY (1998).

(CFI): cut value of  $\geq 0.9$ , Goodness of fit (GFI): cut value  $\geq 0.9$  and Adjusted Goodness of fit (AGFI): cut value  $\geq 0.9$ .

As shown as Table 6, revealed an adequate model fit indicates the model was credible and purified (goodness-of-fit index (GFI) = 0.885; adjusted goodness-of-fit index (AGFI) = 0.836; Tucker–Lewis index (TLI) = 0.943; normed fit index (NFI) = 0.954; root – mean – square residual (RMR) = 0.052; root – mean – square error of approximation (RMSEA) = 0.072).

**Table 6 Goodness of fit indicators**

Indicators	Criteria	Results
GFI	> 0.9	0.885
AGFI	> 0.9	0.836
TLI	> 0.9	0.943
CFI	> 0.9	0.954
RMR	< 0.05	0.052
RMSEA	< 0.08	0.072

Convergent validity is found by examining significant factor loading on each construct. Convergent validity is examined by t-value which is equal to the critical ratio (CR) in AMOS. If a t-value is greater than - 1.96 or lower than 1.96, it accepts its statistical significance. Since Critical ratio is significant at the level of 0.05, it confirms that the construct measured by all indicators are identical and offered rewarding proof of the unidimensional of each construct and convergent validity. Discriminant validity is analyzed by the comparison of Average Variance Extracted (AVE) with the squared correlation between each construct. If the indicators have more common variance with their own construct than any variance that the constructs have with other constructs, it indicates that discriminant validity appears. According to Table 7, it is known that the highest squared correlation is lower than the square roots of AVE of all constructs. Therefore, discriminant validity is confirmed.

**Table 7. Parameter estimate, standard errors, critical ratio, and R<sup>2</sup>**

Factors and scale items	Unstandardized factor loading	Completely standardized factor loading	Standard error (SE)	Critical ratio (CR)	R <sup>2</sup>
Economic issue					
P1	1.328	0.753	0.225	5.894	0.568
P2	1.377	0.867	0.198	6.965	0.751
P3	1.000	0.591	--	--	0.349



Social issue						
P4	1.000	0.893	--	--	0.798	
P5	1.087	1.015	0.062	17.420	1.031	
Environment issue						
P7	1.000	0.712	--	--	0.506	
P9	1.057	0.788	0.114	9.232	0.621	
P10	1.106	0.810	0.116	9.563	0.656	
P11	0.722	0.571	0.109	6.626	0.326	
P12	1.196	0.851	0.121	9.907	0.725	
P13	1.105	0.887	0.108	10.235	0.787	
P14	1.325	0.902	0.128	10.321	0.814	
Retention						
L1	1.000	0.861	--	--	0.742	
L2	0.732	0.577	0.126	5.862	0.333	
L3	0.954	0.703	0.134	7.165	0.494	

Composite reliability (CR) was investigated to assess the reliability and internal consistency within a factor (Awang, 2016). Composite reliability is calculated as  $(\text{sum of standardized loadings})^2 / [(\text{sum of standardized loadings})^2 + (\text{sum of indicator measurement error})]$ , where indicator measurement error is  $1 - (\text{standardized loadings})^2$ . A minimum level of 0.6 is required for a CR to be acceptable. As shown in Table 8, CR values of environmental sustainability, economic sustainability and social sustainability are 0.814, 0.786, and 0.955 respectively, which mean that all the CRs are higher than the required level.

Average Variance Extracted (AVE) was computed to measure the amount of variance that is captured by a factor in relation to the amount of variance due to measurement error. It is calculated as  $(\text{sum of squared standardized loadings}) / [(\text{sum of squared standardized loadings}) + (\text{sum of indicator measurement error})]$ , where indicator measurement error is  $1 - (\text{standardized loadings})^2$ . A minimum level of 0.5 is required for an AVE to be adequate. As shown in Table 8, AVE values of environmental sustainability, economic sustainability and social sustainability are 0.595, 0.556, and 0.914 respectively, which mean that all the AVEs are reaching the required level.

**Table 8 Composite reliability and average variance extracted values**

Factor	Composite reliability	Average variance extracted
Economic	0.786	0.556
Social	0.955	0.914
Environment	0.814	0.595

#### 4.6 Structural Equation Modeling (SEM)

Structural Equation Modeling is the combination of factor analysis and multiple regression analysis. It can analyze the relationship between measured variables and represented by path coefficient between the factors.<sup>1</sup>

In this section, the SEM was applied to examine the relationships among environment sustainable, social sustainable, economic sustainable and retention. The data, as shown in Figure 2, supported the estimated model effectively. All the relationships were significant in the expected way. The relationship between environmental sustainability performance with retention was significant (estimate = 0.38, CR = 5.11), economic sustainability performance associated with retention also had significant relationship (estimate = 0.61, CR = 3.58), whereas the relationship between social sustainability and retention was not significant compared to other two sustainability performance (estimate = - 0.02, CR = - 0.38).

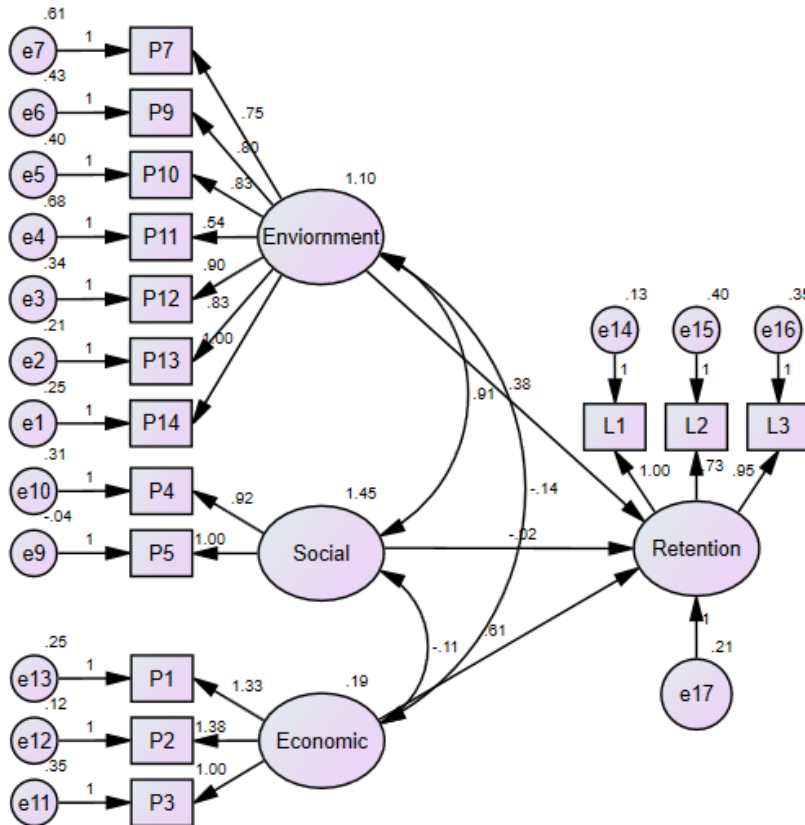

Figure 2 Result of SEM

<sup>1</sup> Hox, J.J, Bechger, T.M., An introduction to structural equation modeling, The Family Science Review, 11, 354-373 (1998).

#### ***4.7 Differences of port workers, shipping company employees and nearby residents in the importance and performance of sustainability assessment criteria***

An investigation of the opinion differences between different types of respondents (port workers, shipping company employees, and nearby residents) was conducted (see Table 9). For importance, social sustainability (mean = 4.44) was viewed as the most agreed factor by respondents, followed by economic sustainability (mean = 4.34) and environmental sustainability (mean = 4.01) as the least important. For performance, economic sustainability assessment criteria have the best performance (mean = 4.00) by respondents, followed by social sustainability (mean = 3.26), and environmental sustainability as the worst performance (mean = 2.82) (see Table 10). The P values of all criteria in both importance and performance are all smaller than 0.05, meaning the responses difference between the three types of respondents are significant.

##### ***4.7.1 The nearby residents' point of view***

50 nearby residents have responded to the questionnaire. Regarding importance, environmental criteria have the highest importance of mean scores ranging from 4.26 to 4.38, followed by social criteria with a mean of 4.16 and economic criteria with a mean of 4.09. "Considering 3R (reduce, reuse, recycle) when handling cargo" with a mean of 4.38, is considered as the most important criteria in the view of nearby residents. Regarding performance, social criteria with a mean of 3.66 have the best performance in the view of nearby residents, followed by economic criteria with a mean of 3.57. Environmental criteria which have the highest importance, however, have the lowest performance of mean ranging from 2.78 to 3.08. "Ensuring cargo handled safely and effectively" and "Terminal traffic accidents prevention" have mean of 3.68 are the criteria with the best performance.

##### ***4.7.2 The shipping company employees' point of view***

44 employees include both office workers and crew members have responded to the questionnaire. Regarding importance, economic and social sustainability with means of 4.77 and 4.75 respectively are more important among shipping company respondents; environmental sustainability is less important with a mean of 4.32. "Ensuring cargo handled safely and effectively" with a mean of 4.91, is considered as the most important criteria in the view of shipping company. Regarding performance, the performance in economic and social sustainability assessment criteria are the same with both means of 3.98; performance in environmental sustainability assessment criteria are relatively lower with a mean of 3.39 in the view of shipping company respondents. "Ensuring cargo handled safely and effectively" has mean of 4.02 are the criteria with the best performance.

**Table 9** Importance difference between nearby residents, shipping company employees, and port workers

Code	Importance of sustainability Criteria	Nearby residents		Shipping Company		Port Workers		F value	P value	Scheffe
		Mean	SD	Mean	SD	Mean	SD			
I1	Facilitating to economic activities	4.08	0.53	4.57	0.63	4.14	0.99	5.84	0.00	(1,2) (2,3)
I2	Ensuring cargo handled safely and effectively	4.16	0.51	4.91	0.29	4.20	0.97	18.41	0.00	(1,2) (2,3)
I3	Offering employment opportunities	4.04	0.53	4.82	0.45	4.34	0.90	16.35	0.00	(1,2) (2,3)
I4	Employee job security and safety	4.18	0.48	4.75	0.44	4.50	0.89	9.33	0.00	(1,2) (1,3)
I5	Terminal traffic accidents prevention	4.14	0.54	4.75	0.44	4.42	0.95	9.24	0.00	(1,2)
I7	Decreasing noise pollution in Kwai Tsing District	4.28	0.61	3.64	0.78	3.02	0.96	31.36	0.00	(1,2)(1,3) (2,3)
I9	Disposing of effluents and maintaining water quality in Kwai Tsing District	4.36	0.63	4.64	0.49	3.22	0.93	53.04	0.00	(1,3) (2,3)
I10	Mitigating light influence on neighboring residents	4.32	0.51	3.84	0.61	3.14	0.87	38.29	0.00	(1,2)(1,3) (2,3)
I11	Considering 3R (reduce, reuse, recycle) when handling cargo	4.38	0.57	4.41	0.64	3.76	1.15	9.40	0.00	(1,3) (2,3)
I12	Maintaining air quality in Kwai Tsing District	4.36	0.56	4.68	0.47	3.62	0.86	32.81	0.00	(1,3) (2,3)
I13	Ecological environment protection in terminal area	4.26	0.63	4.43	0.70	3.54	0.91	18.84	0.00	(1,2)(1,3) (2,3)
I14	Ensuring proper waste disposal	4.34	0.52	4.64	0.49	3.52	0.97	32.34	0.00	(1,2)(1,3) (2,3)

**Table 10 Performance difference between nearby residents, shipping company employees, and port workers**

Code	Criteria	Nearby residents		Shipping Company		Port Workers		F value	P value	Scheffe
		Mean	SD	Mean	SD	Mean	SD			
P1	Facilitating to economic activities	3.40	0.50	3.82	0.58	4.48	0.83	28.24	0.00	(1,2)(1,3) (2,3)
P2	Ensuring cargo handled safely and effectively	3.68	0.55	4.20	0.63	4.58	0.58	29.86	0.00	(1,2)(1,3) (2,3)
P3	Offering employment opportunities	3.62	0.49	3.91	0.64	4.38	0.83	16.39	0.00	(1,3) (2,3)
P4	Employee job security and safety	3.64	0.56	3.95	0.53	2.28	1.55	37.05	0.00	(1,3) (2,3)
P5	Terminal traffic accidents prevention	3.68	0.47	4.00	0.53	2.16	1.33	60.08	0.00	(1,3) (2,3)
P7	Decreasing noise pollution in Kwai Tsing District	2.88	0.87	3.43	0.55	2.24	1.39	16.25	0.00	(1,2)(1,3) (2,3)
P9	Disposing of effluents and maintaining water quality in Kwai Tsing District	2.94	0.71	3.61	0.54	2.38	1.35	19.77	0.00	(1,2)(1,3) (2,3)
P10	Mitigating light influence on neighboring residents	3.08	0.88	3.36	0.49	2.10	1.27	23.60	0.00	(1,3) (2,3)
P11	Considering 3R (reduce, reuse, recycle) when handling cargo	2.78	0.65	2.52	0.55	1.76	1.30	16.90	0.00	(1,3) (2,3)
P12	Maintaining air quality in Kwai Tsing District	2.92	0.85	3.64	0.49	2.34	1.38	19.95	0.00	(1,2)(1,3) (2,3)
P13	Ecological environment protection in terminal area	3.06	0.65	3.41	0.50	2.26	1.24	21.82	0.00	(1,3) (2,3)
P14	Ensuring proper waste disposal	3.02	0.99	3.73	0.69	2.14	0.45	30.95	0.00	(1,2)(1,3) (2,3)

#### ***4.7.3 The port workers respondents' point of view***

50 port workers have responded to the questionnaire. Regarding importance, social and economic criteria with 4.46 and 4.23 respectively are more important among port workers respondents, environmental sustainability is less important with a mean of 3.40. "Employee job security and safety" with a mean of 4.50, is considered as the most important criteria in the view of port workers. Regarding performance, the performance of economic sustainability with a mean of 4.48 has the best performance in the view of port workers. Social and environmental sustainability criteria with a mean of 2.22 and 2.17 have weaker performance. "Ensuring cargo handled safely and effectively" has mean of 4.58 are the criteria with the best performance.

#### **Discussion and Conclusions**

Since port is one of the main nodes in the global supply chain networking, the number of cargo shipped by sea and the amount of waterborne commerce has been growing gradually. Suppose the acceleration of human economic development is greater than the recovery rate of natural resources, it will form a destructive impact on the planet in long run. Therefore, the port operators have an obligation to maintain a balance among profit maximization, social concern and environment which is as known as "sustainability". Given sustainability is a complex issue, it is necessary to break down the issue into a smaller-scale indicator for measurement and assessment.

Our research aims to identify various crucial sustainability criteria and its impact on stakeholder's retention at Hong Kong container port. The key findings of the research are found via the questionnaire survey conducted in Kwai Tsing container terminals and Kwai Tsing District and are summarized as below.

In this research, the questionnaire was initially undergone to evaluate the level of agreement / satisfaction from the point of view of the respondents in terms of the importance and performance of different sustainability criteria. Then, factor analysis has been adapted to reduce, re-arrange and thus test the variables into critical factors. In addition, the implication of AMOS establishes a structural equation model (SEM) to examine the significance of the criterion.

Data collection are constructed by a questionnaire of 144 respondents including 44 shipping companies' employees, 50 employers at Kwai Tsing container terminals and 50 residents living in Kwai Tsing District. A total of 14 relevant sustainability assessment criteria were selected from the past researches conducted by several scholars. It is revealed that our respondents regarded social dimension such as "Terminal traffic accidents prevention" as the most important sustainability dimension. It can be generalized as labor's right and equality in port. It is followed by economic dimension including criteria like "ensuring cargo handled safely and effectively". The economic dimension concerns itself with profit maximization and operational efficiency. Lastly, environmental dimension concerning environmental policy such as "maintaining air quality in Kwai Tsing District" is regarded as the least important dimension among the three dimensions. In terms of the performance, the performance of economic dimension has the best-ranking, followed by social dimension and then environmental dimension. According to

information - performance matrix, 14 sustainability criteria has been categorized into three quadrants respectively. There are five sustainability criteria which fall into Quadrant I “Keep up the good work”. Regarding the indicators in Quadrant I, it is suggested to focus on the reformulation of labor safety policy and the offering of welfare and allowance. There are five sustainability criteria which fall into Quadrant II “Concentrate Here”. Regarding the criteria in Quadrant 2, it is highly advised that the investment should be involved in this area. Also, four sustainability criteria which fall into Quadrant III “Lower Priority”. Regarding the criteria in Quadrant III, it is suggested to implement more cost-effective measures to deal with the problems. Since Quadrant III is not prioritized, the resources are relatively less allocated to Quadrant III.

Based on Confirmatory Factor Analysis (CFA), it is known that SEM indicators are eligible to meet all the criteria requirements, confirming the validity of three dimensions to undergo AMOS model analysis. Furthermore, with the help of the usage of AMOS, it is found that all relationship between all three dimensions is significant as expected. With that said, it is also found that environmental dimension and economic dimension shares a significant relationship with the retention while social dimension shares an insignificant relationship with the retention.

In the difference between shipping companies’ employees, residents and port workers, it is essential to address and acknowledge the difference in the responses of the three types of respondents. It is because the P-value of all sustainability criteria in both importance and performance are less than 0.05.

Theoretical and practical implication obtained from the results of the assessment for sustainability criteria is discussed in the study. Even though there is a great deal of sustainability assessment research conducted by the researchers, there are still having lack on the evaluation of sustainability criteria at Hong Kong port from a stakeholder’s perspective. The study facilitates the development of different indicators for sustainability and emphasizes the important criteria for future investigation. Furthermore, the research can serve as the ground for sustainability policy-making in port operation for a more precise regulation.

Important contributions are made from the research. From the practical perspective, spotting out the strengths and weaknesses of current operation provides a major implication for business decision making in the foreseeable future. In order to have a successful implementation of sustainability policy, it is necessary to highlight the weakness and focus on the improvement for these areas. Another contribution made is to enlighten the board of directors to raise the awareness of environmental protection with solid and scientific evidence. Since the research evaluates the actual situation in Kwai Tsing container terminals and includes many stakeholders, it reflects and presents the reality with actual data and facts. Therefore, it is fair to state that the research has made important practical contribution.

In the light of theoretical contribution, this paper makes major contribution as well. Firstly, it deepens the understanding of sustainability performance. It is found that there is not a lot of academic paper specializing in the performance of a certain dimension in sustainability. Yet, a lot of papers focus on the idea of “sustainability” as a whole as the

discussion topic. Our research can serve as a guideline for further investigation into the operation and management of ports in different major ports in Hong Kong. This is significant because it offers different insight and useful input to future researchers by displaying different adaptation of analysis models and data collection methods. Therefore, it is acceptable to claim that productive contribution has been done from the theoretical perspective.

The following specific recommendations and suggestions are developed for terminal operators' reference. It is vital for port operators to include the interest of external consumers and supply chain partners such as transportation companies in their sustainability policy to advance the sustainability performance. This should be done so that, the implementation of sustainability practices could encounter less friction and can be effectively carried out. Secondly, port operators are suggested to encourage transparent and effective communication among the staffs, allowing the involvement of the employees in the sustainable development policy. A tight cooperation with the employees allows the company to have a better design for the sustainability goals and regulations and better engagement in the training programs for the implementation of new policies. An internal sustainability practice and the collaboration with the external organization in sustainability action are positively linked to a positive change in the performance of sustainability. Therefore, it is essential to introduce an adequate sustainability practice within the container terminal.

In the quadrant I: High importance and high performance, there are five main criteria in this quadrant: Employee job security and safety, terminal traffic accidents prevention, ensuring cargo handled safely and effectively, offering employment opportunities and facilitating to economic activities. These five main criteria were essential and performed well in the Kwai Tsing Container Terminal according to the questionnaire completed by residents, port workers and shipping companies. As long as they are effective and efficient in port sustainability development, some recommendations will be given to keep up on those five criteria in order to achieve improvement of port sustainability. For the employee job security and safety, 'Work Safe Behavior Program' can be launched. In order to enhance workers health consciousness, the program will be a group of safety observers received training from the Occupational Safety and Health Council then went to different shipping companies to observe and identify any improper work behavior. Providing advice and encouraging the operators to stretch before operations to increase the flexibility, joint of movement and relax muscle. This can lower the risk of injury during the operation e.g. back injury, knee injury and wrist injury etc. For the terminal traffic accidents prevention, a "Safe Driving Event" can be rolled out to raise staff awareness on safe driving practices. In order to drive awareness and equip drivers with techniques to prevent accidents, the container port can be cooperated with the Hong Kong Police Force to conduct a safe driving talk. In this event, hazard perception in driving and safe driving behavior will be trained for the drivers to eliminate the risk of accidents in the container port. For the ensuring cargo handled safely and effectively and facilitating to economic activities, enhancing turnover can improve the terminal handling cargo faster and safer to achieve facilitating economic activities by increasing automation in the port operation. To



commission a 'ghost ship' with fully automated berths with ship – to – shore cranes, stacking cranes associated with automated guided vehicles (AGV), it can enhance the cargo handling efficiency and safely with enhancing turnover rate to achieve facilitating economic activities. For the offering employment opportunities, the container port can promote the jobs and provide allowances for the employees. As long as the Kwai Chung Container Terminal is far from the city and MTR station, only minibus and taxi can enter the terminal area. It is hard to get access into it, therefore, promoting the job is important with higher allowances for the employees can attract people to get a job in the container port.

In quadrant II: High importance and low performance, there are five main criteria in this quadrant: Disposing of effluents and maintaining water quality in Kwai Tsing District, considering 3R (reduce, reuse, recycle) when handling cargo, maintaining air quality in Kwai Tsing District, Ecological environment protection in terminal area and Ensuring proper waste disposal. These five main criteria were essential but poorly performed in the Kwai Tsing Container Terminal according to the questionnaire completed by residents, port workers and shipping company. Some suggestions are given to these criteria correspondingly. For disposing of effluents and maintaining water quality in Kwai Tsing District, it is suggested that port operators can cooperate with the public sector in the Harbor Area Treatment Scheme. With the aid of the scheme, port operators can examine the water quality from time to time and identify the main source of water pollution. So that, port operators can make an adequate adjustment to its operational activities to reduce the impacts imposed to the environment. For maintaining air quality in Kwai Tsing District, it is suggested to invest on the improvement of the facilities at ports. For example, installing cutting edge filtering technology to improve air quality. High-efficiency air filtering can help the ports to have a better control of their pollutant outputs and provide a better workplace environment to low-ranking port workers, creating a win-win situation by cutting edge filtering system. For ecological environment protection, it remains unknown how much responsibility port operators are to bear. Therefore, it is highly advised that port operators should have consultations with environmentalist organizations. Environmentalist organizations would offer different professional recommendations for ecological environment protection, in order to maintain the biodiversity near the ports at a steady level. For considering 3R (reduce, reuse, recycle) when handling cargo and ensuring proper waste disposal, it is recommended that the company can implement a new waste disposal policy. The staffs have different arrangement and requirement while dealing with waste. There should be a self-monitoring policy within the port operation to ensure that waste is handled appropriately. Also, it is essential to conduct regular training and education to educate port workers about proper disposal measures and by so doing, raise the awareness of environmental protection and clarify the procedures of the waste disposal.

Regarding criteria with low importance and low performance, they will have lower priority in the development plan. Due to the low priority, resources allocated for these criteria will be less. Thus, lower cost measures should be adopted. For decreasing noise pollution in Kwai Tsing District and mitigating light influence on neighboring residents,

port operators can cooperate with the property companies in Kwai Tsing districts to use noise barrier material and thick curtains in the renovations of apartments so that the influences from excessive light or noise can be reduced. For enhancing container terminal landscape and providing fair job opportunities, the port operators should supervise and control the behavior of their outsourcing labor supplier, ensuring the service quality in maintaining a clean and tidy terminal area, and a fair hiring process.

While the paper makes a valuable contribution in the light of theoretical and practical implications, there are still a number of limitations in this study. Firstly, the scope of the research is limited to time and financial restriction. Since the duration of the project is one year, the focus group needs to be narrowed down for the context of the research. As a result, there are three types of parties involved in the research while there are still a number of stakeholders' opinions that should be included in the sustainability of port operation. Also, the sample size is relatively small which has 144 respondents in our questionnaire. Therefore, the authority and representability of the questionnaire could be challenged and doubted since the number of respondents might not be sufficient to represent the stakeholders as a whole. Besides, the data collected from the respondents are their subjective opinions towards the sustainability performance. The result might not be reliable since the respondents are very likely to be unwilling to review the performance truthfully for the sake of their interest and the avoidance of unnecessary backlash against the respondents themselves. It is suggested to adopt more objective measures for information accuracy.

In order to evaluate the sustainability of Hong Kong port operation, it is necessary to level up on the scale of the research. The timeframe of the research can be lengthened to conduct a longitudinal study to assess sustainability. Moreover, the research should involve more stakeholders to increase the validity of the survey.

Editor (English): Nii Sowah

# 中国无人船的政策与法律规则应对

韩立新\* 夏文豪\*\*

**【摘要】**中国政府和相关行业积极应对无人船技术所带来的挑战，针对无人船研发出台了许多重要政策和规范文件。本文对中国无人船研发政策、规范和标准、法律应对等方面进行了研究，发现中国现行的法律规范体系大体上可以适用于无人船，但是部分规则需要进行修改和补充。针对中国海事管理类法律规则和海商法主要制度适用于无人船时存在的问题，本文也提出了相关的应对建议。

**【关键词】**无人船 政策 法律规则 应对

## 引言

近些年，无人船的技术发展突飞猛进。2017年12月，全球第一艘万吨级智能船舶通过伦敦船级社认证，正式交付使用。2018年8月，挪威航运公司威尔森集团和康士伯合资成立的世界第一家无人船航运公司——“Massterly”全面投入运营。2019年9月，日本航运公司日本邮船株式会社 NYK 在其官方网站宣布其已根据国际海事组织相关临时指南成功进行了世界上第一次海上自主水面船舶试验。2020年4月，荷兰皇家加勒比邮轮公司旗下银海邮轮“银海起源”号在戈雷飞越科海岸成功进行了世界首次邮轮远程遥控海试。

在中国，2018年12月1日，亚洲首个、世界最大的无人船海上测试场——珠海万山无人船海上测试场宣布启用，并获得了中国船级社授予的测试场服务供应方认可证书。2019年12月15日，中国首艘自动驾驶货船“筋斗云0号”在珠海东澳岛成功完成了首次自主货船货物运载。2020年5月，中国首艘自主航行集装箱商船“智飞”号在青岛开工建设。

为了应对无人船技术发展所带来的挑战，国际社会和国内各方主体都在积极探索、制定和完善相关规则、规范。在国际公约规则、标准规范方面，国际海事组织成立了海上水面自主船舶工作组，对无人船进行了定义与分级，并启动了无人船相

---

本文为大连市人力资源和社会保障局第二批领军人才资助项目“无人船技术研究及营运法律保障研究”阶段性成果

\* 韩立新（1967—），女，汉族，河北秦皇岛人，大连海事大学法学院教授、博士生导师，研究方向为海商法。E-mail: [hanlixin@dlnu.edu.cn](mailto:hanlixin@dlnu.edu.cn);

\*\* 夏文豪（1993—），男，汉族，江苏盐城人，大连海事大学博士研究生，研究方向为海商法。E-mail: [xwh0150@dlnu.edu.cn](mailto:xwh0150@dlnu.edu.cn);

©THE AUTHOR AND MARINE LAW AND POLICY

关法规梳理和适用性分析工作，制定了无人船试航指南。国际船级社协会发布了12项针对船舶网络安全的建议案。国际标准化组织、国际电工委员会、国际电信联盟等都在注与开展相关标准的制定工作。中国作为航运大国，对无人船的发展也给予了充分的关注，近五年来陆续出台了支持无人船的相关政策和规范、指南。在法律规则制定方面也在抓紧研究。本文将对中国无人船研发政策、规范和标准、法律应对等方面加以介绍和讨论。

## 一、中国关于无人船研发的政策及现行相关标准

### （一）中国船级社《智能船舶规范》

2016年3月1日，中国船级社编制的《智能船舶规范（2015）》正式开始生效。该规范是全球首部《智能船舶规范》<sup>1</sup>，采用目标型标准的制定方法，是一个开放式的船舶规范。在功能上，该规范将智能船舶划分为智能航行、智能船体、智能机舱、智能能效管理、智能货物管理和智能集成平台六大板块，并分六个章节对各个功能板块的一般要求、功能标志、图纸资料、检验和试验进行了规范。中国船级社还陆续制定了《船舶智能机舱检验指南（2017）》《智能集成平台检验指南（2018）》《船舶智能能效管理检验指南（2018）》《船舶（油船）智能货物管理检验指南（2018）》《船舶网络系统要求及安全评估指南（2020）》，对《智能船舶规范》作补充规定和详细规定。

2020年3月1日，《智能船舶规范（2020）》生效，在原有规范框架下，增设远程控制和自主操作两项功能板块，并对其对应的一般要求、功能标志附加要求、设备配备与性能要求和检验与试验要求作出了较为细致的规范。

### （二）中国船级社《无人水面艇检验指南（2018）》

2018年1月1日，中国船级社编制的《无人水面艇检验指南（2018）》（以下简称《无人艇指南》）正式开始生效。《无人艇指南》对入级检验、总体目标及功能要求、通信系统、操控系统、艇体、轮机、电气、航行和信号设备提出了要求，针对不同的航行模式（自主航行、远程遥控）和距岸距离，授予不同的附加标志。2018年8月1日，《无人艇指南》2018第1次变更通告生效，新增了入级符号、附加标志和检验要求。

《无人艇指南》仅适用于艇长大于等于5米但小于20米的无人艇的设计、建造和检验，超过该尺度范围的无人艇可参照执行。《无人艇指南》覆盖无人艇的图纸审查、产品检验、建造中检验和建造后检验各个阶段，并针对无人艇的三大组成部分通信系统、操控系统和平台（包括艇体、轮机、电气以及航行和信号设备）分别考虑，对其进行风险评估，提出具体的安全技术要求。

### （三）中国船级社《自主货物运输船舶指南（2018）》

2018年10月1日，《自主货物运输船舶指南（2018）》（以下简称《自主货船

---

<sup>1</sup> 马金星.人工智能船舶引领国际海事规则体系变革.中国海洋报,2019-10-08.

指南》)正式生效。《自主货船指南》针对第三级和第四级自主化水平的无人船<sup>1</sup>,采用目标型标准方法,对自主货物运输船舶的构造、船舶各系统的目标、功能要求、规定要求以及检验与试验要求作出了规定。章节内容包括:场景感知、航行控制、轮机装置、系泊与锚泊、电气装置、通信与信号设备、船体构造与安全、消防、环境保护、船舶保安、远程控制中心、网络安全等。

#### (四)《智能船舶发展行动计划(2019-2021年)》

2018年12月27日,工业和信息化部、交通运输部、国防科工局联合印发《智能船舶发展行动计划(2019-2021年)》(以下简称为《船舶发展行动计划》),对智能船舶的发展规划作出全面的指导说明,将建立智能船舶标准体系列为行动目标和重点任务,明确提出研究制定智能船舶规范和标准体系建设指南。

《船舶发展行动计划》分析判断了当前智能船舶发展的形势,指出全球智能船舶仍处于探索和发展的初级阶段。在此背景下,中国应当加快发展智能船舶产业,抢占世界智能船舶产业发展高地。《船舶发展行动计划》明确提出,要经过三年努力,形成中国智能船舶发展顶层规划,初步建立智能船舶规范标准体系,突破航行态势智能感知、自动靠离泊等核心技术,完成相关重点智能设备系统研制,实现远程遥控、自主航行等功能的典型场景试点示范,扩大典型智能船舶“一个平台+N个智能应用”的示范推广,初步形成智能船舶虚实结合、岸海一体的综合测试与验证能力,保持中国智能船舶发展与世界先进水平同步。

#### (五)《推进船舶总装建造智能化转型行动计划(2019-2021年)》

2018年12月27日,工业和信息化部、国防科工局联合发布《推进船舶总装建造智能化转型行动计划(2019-2021年)》(以下简称《船舶建造转型行动计划》),对船舶总装智能化转型的发展规划作出全面的指导说明,将初步建立船舶智能制造技术创新体系和标准体系列为主要目标,加快提升船舶建造技术水平。

《船舶建造转型行动计划》提出了五大方面15项重点任务,并设置5个重点专栏。五大方面包括:攻克智能制造关键共性技术和短板装备;夯实船舶智能制造基础;推进全三维数字化设计;加快智能车间建设;推动造船数字化集成与服务。5个重点专栏包括:船舶智能制造关键共性技术研发重点;船舶智能短板装备研制重点;船厂信息基础设施建设重点;船舶智能制造标准体系建设重点;推进全三维数字化设计工作重点。

#### (六)《智能航运发展指导意见》

2019年5月9日,交通运输部等七部门联合发布《智能航运发展指导意见》(以下简称为《意见》),明确了智能航运培育和发展的总体要求、主要任务和保障措施。

---

<sup>1</sup> 国际海事组织海事安全委员会为了便于无人船舶的监管范围界定工作的进行,按照自动化程度将无人船舶分为了四级:第一级是拥有自动化处理和决策支持功能的船舶;第二级是海员在船但被远程控制的船舶;第三级是无海员在船但被远程控制的船舶;第四级是完全自主的船。

《意见》要求，到2020年底，基本完成智能航运发展顶层设计；到2025年，突破一批制约智能航运发展的关键技术，成为全球智能航运发展创新中心；到2035年，较为全面地掌握智能航运核心技术，智能航运技术标准体系比较完善；到2050年，形成高质量智能航运体系。《意见》明确十项主要任务，涵盖顶层设计、技术应用与创新、保障体系、法规标准与监管机制、人才培养等各个方面。

#### （七）《智能船舶标准体系建设指南（征求意见稿）》

2019年9月12日，工信部装备工业司发布《智能船舶标准体系建设指南（征求意见稿）》（以下简称《指南》（征求意见稿））。2020年4月30日，工信部装备工业司联合国家市场监督管理总局标准技术司发布新版《指南》（征求意见稿）。两版《指南》（征求意见稿）都对智能船舶标准建设的总体要求、体系框架、建设内容和组织实施作了规定。

根据新版《指南》（征求意见稿），建设目标分为两个阶段，每个阶段安排有不同的目标。第一阶段为2020年至2021年，要求对智能船舶术语定义、分级分类等基础共性标准形成支撑，在智能船舶关键技术应用标准方面取得突破，智能船舶设计、智能船载系统及设备、智能船舶测试与验证标准满足实船建造需要。第二阶段为2022年至2025年，要求智能船舶基础共性、关键技术应用、智能船舶设计、智能船载系统及设备、智能船舶测试与验证专业标准体系基本形成，岸基服务、运营管理标准配套完善，标准体系进一步健全。

新版《指南》（征求意见稿）将标准体系框架分成三层架构：标准体系顶层、七个部分、38个专业及领域。建设内容包括七个方面，分别为：（1）基础共性标准；（2）关键技术应用标准；（3）智能船舶设计标准；（4）智能船载系统及设备标准；（5）智能船舶测试与验证标准；（4）岸基服务标准；（5）运营管理标准。

通过以上政策文件和规范、指南内容可以看出，中国政府有关部门高度重视智能船舶的研发，强调要有顶层设计，注重共性和关键技术的研发应用，在测试场、船检规范、标准体系建设等方面都给予充分保障，在一定程度上，政策和规范、标准的制定走在了无人船研发设计之前。

## 二、中国法下无人船的法律地位

目前，无论是中国国内立法还是国际条约，都没有关于无人船的专门法律。除中国参加的有关船舶防污染和安全类、民事责任类国际公约（如UNCLOS 1982、MARPOL73/78、STCW、SOLAS、MLC、OPRC 1990、CLC、BANKER CONVENTION等）外，中国与船舶有关的管理类法律主要是《海上交通安全法》《海洋环境保护法》《防治船舶污染海洋环境管理条例》《船舶登记条例》《船员条例》《船舶和海上设施检验条例》及《船舶检验管理规定》等等；与船舶营运民事责任有关的法律则主要是《海商法》。中国的现行法律是否能适用于无人船呢？这主要取决于中国法律中对于相关“船舶”概念的规定是否适用于无人船。

### （一）海事管理类法律对无人船的适用

国际海事委员会的无人船国际工作组在其发布的调查问卷和立场文件中将无

人船描述为“能够受控制地在水上移动而没有任何船员在船上”，通过该定义可以归纳出无人船的构成要件为以下四点：（1）在水上；（2）可移动；（3）移动受控制；

（4）不搭载船员。依照控制的方式，又可将无人船划分为遥控无人船和自控无人船。遥控无人船是岸基控制人员远程控制船舶移动，而自控无人船则是依照预先编写好的程序在没有人工干预的情况下自行移动。与一般的船舶相比，较有争议的问题在于船上不搭载船员是否影响其构成“船舶”。

《海上交通安全法》第50条规定，“船舶”是指“各类排水或非排水船、筏、水上飞机、潜水器和移动式平台”；《船舶登记条例》第56条规定的“船舶”为“各类机动、非机动船舶以及其他水上移动装置，但是船舶上装备的救生艇筏和长度小于5米的艇筏除外”；《船舶和海上设施检验条例》第29条规定：“船舶，是指各类排水或者非排水船、艇、水上飞机、潜水器和移动式平台”。以上对于“船舶”的定义，都没有包含需要搭载船员这一要件。因此，从文义解释的角度来看，不管是遥控无人船还是自控无人船，不管有没有船员在船上，“无人船”都满足“船舶”的定义要求，应属于上述法律法规的调整对象。

在国际海事委员会发布的调查问卷中，第1.1问为“一艘超过500总吨的无人货船是否在国内法中构成船舶？”除克罗地亚一国给出了否定答复，包括中国在内的其余18个国家都认为其构成船舶。<sup>1</sup>经过上述分析，既然无人船构成船舶，中国现行的海事管理类法律应该适用于无人船。但是，与此同时，我们也应当注意到，无人船在适用国内海事管理类法律时所存在的种种问题，包括但不限于：船舶配员要求的限制；船员资格、船员义务履行方面的不适；船舶国籍取得的困难；船舶检验具体技术规则的缺失。

## （二）民事责任类法律对无人船的适用

中国《海商法》是船舶相关的民事责任最重要的法源，其中第3条规定：“本法所称船舶，是指海船和其他海上移动式装置，但是用于军事的、政府公务的船舶和20总吨以下的小型船艇除外。”十三届全国人大常委会立法规划9月7日公布，需要抓紧工作、条件成熟时提请审议的二类立法项目47件，《海商法》修改被列入二类立法项目之一。不过，在交通运输部启动修改审核的《海商法》修改征求意见稿中，对“船舶”的定义也没有作出变更。因此，与海事管理类法律一样，《海商法》的“船舶”定义中也没有对配备船员作出要求，无人船符合《海商法》对船舶的定义。

## 三、中国海事管理类法律规则对无人船的应对思考

经过上面分析，虽然无人船属于船舶，但是现行海事管理类法律对其直接适用会产生一些不适。目前，处于试验航行阶段的多是遥控无人船，完全自主的自控无人船在可以预期的很长一段时期内都难以大规模商用，甚至有观点认为，我们可能

<sup>1</sup> Summary Of Responses To The CMI Questionnaire. <https://comitemaritime.org/work/unmanned-ships/>. 访问日期：2019.11.13.

永远都无法看见完全自主的远洋货船。<sup>1</sup>在未来很长的一段时间内，更可能出现的是遥控无人船与有人船共存的局面。因此，本文主要针对遥控无人船提出中国海事管理类法律规则的应对建议，并适当为自控无人船的发展留有空间。

### （一）船员配备与船员职责

在传统航运领域，货船都是配备船员航行。中国国内法也不例外地要求船舶应当配备足够数量的船员，例如《海上交通安全法》第6条规定“船舶应当按照标准定额配备足以保证船舶安全的合格船员”。这就引起了一个问题：从体系解释的角度分析，该条款是否意味着配备或者能够配备船员是船舶的构成要件？

我们应结合“按照标准定额”和“足以保证船舶安全”这两个限定条件来看待这个问题。“按照标准定额”意味着船员数量是根据不同情况而变化的，正如《船舶最低安全配员规则》第6条所规定的：“确定船舶最低安全配员标准应综合考虑船舶的种类、吨位、技术状况、主推进动力装置功率、航区、航程、航行时间、通航环境和船员值班、休息制度等因素。”考虑到无人船的特殊船舶种类、先进的技术水平、不需要考虑船员轮休的优势因素，在确定无人船的船舶配员时进行船员人数上的缩减，直至不需要船员存在也是可以理解的。“足以保证船舶安全”指出了配备船员的目的，而这点正是无人船的优势所在。据统计，通常认为80%左右的海上事故都是人为因素导致。根据欧洲海事安全局近期发布的《2019年度海上伤亡事故年度报告》，在调查期间分析的总共4104起事故中，仍有65.8%的海上事故发生原因归咎于认为失误。<sup>2</sup>无人船技术排除了人为因素的干扰，相比而言，更有利于保证船舶的安全。

同时，无人船由于船员的缺位，《船员条例》中对于船员的资格认定、船员职责、船员培训等方面的规定也无法适用。对于遥控无人船的岸基控制人，是否属于船员，国际上还没有定论。

从国际法的层面来看，现行的STCW公约仅适用于在船上的船员，但是其也可能被修订以涵盖岸基控制人员。<sup>3</sup>2019年9月举办的IMO海上自主航行船舶会间工作组会议对STCW公约中船员的定义进行了讨论，工作组认为，如若将岸基控制人员认定为船员并适用STCW公约，则公约中关于无人船的条款需要被再次讨论。Eric Van Hooydonk认为，对于承担无人船航行总体责任的岸基控制人员，强调“船长”在船舶航行中有最高的层级位置的定义是足够宽泛到涵盖岸基控制人员的。同时，Hooydonk也提及，相较而言，岸基控制人员一方面免于国际环境、身体健康、安

---

<sup>1</sup> 沃桑海事。观点：为什么我们永远不会看到完全自主的远洋货船？

[https://mp.weixin.qq.com/s?\\_\\_biz=MjM5NTQ3MzYxMA==&mid=2650708166&idx=1&sn=550b5f8b6db5ad738fefb0150b99e6bb&chksm=befdc963898a407594a5dde0fd08e736bc2d6d4e6d9213f3378ddf08d08c81633cc41c07420d#rd](https://mp.weixin.qq.com/s?__biz=MjM5NTQ3MzYxMA==&mid=2650708166&idx=1&sn=550b5f8b6db5ad738fefb0150b99e6bb&chksm=befdc963898a407594a5dde0fd08e736bc2d6d4e6d9213f3378ddf08d08c81633cc41c07420d#rd)。访问日期：2019.11.13。文中观点源自：CDR David Dubay, USCG Maritime Security, Russia, Arctic.

<sup>2</sup> Annual Overview of Marine Casualties and Incidents 2019, 载于海事服务网 CNSS, 访问日期：2019.11.11.

<sup>3</sup> Allen, Craig H. Determining the legal status of unmanned maritime vehicles: formalism vs functionalism. *Journal of Maritime Law and Commerce*, Vol. 49, Issue 4 (October 2018), pp. 489.



全风险、纪律、长期在船上工作和远离家乡、家庭和社会生活受限制等传统船长的负担,因此难以找到有效的理由将其纳入海事法的调整范围;另一方面岸基控制人员也需要像传统船长一样具备良好的判断能力、沟通能力、决策能力和必要的航海知识和信息技术知识,以承担起运输、避碰、防止污染等责任。<sup>1</sup>也有学者认为,即使是在传统船舶上,尽管船长担负总体的航行责任,船长也不总是在驾驶室。但是,船长在船舶上确实能起到重要的安全作用,因为沿岸国有了执行海事责任的对象。无人船的岸基控制人员可以被认定为船长,但是必须解决沿岸国执行海事责任的对象问题。<sup>2</sup>

国内法层面上,国际海事委员会曾发布调查问卷对岸基控制人员是否构成国内法的“船长”(第1.4.1问)和“船员”(第1.5问)进行调查。调查结果显示,被调查的19个国家中,仅有3个国家(包括中国)将“船长”定义为在船上的人,6个国家的海商法协会表示其认为或是不排除首席岸基控制人员可能构成船长;10个国家(包括中国)的海商法协会回复其国内法中有对“船员”的定义,并且除了巴西都明确要求船员在船上,8个国家(包括中国)的海商法协会认为其国内法中对船员的定义不能涵盖岸基控制人员。可见,各国国内法对于“船员”和“船长”的定义区别还是挺大的,由此造成岸基控制人员在各国的法律地位也有所不同。正如国际海事委员会所总结的,那些强调船员工作职责的定义更容易将岸基控制人员认定为船员,而强调船员“在船上”任职的定义则更容易将岸基控制人员排除在船员范围之外。

国内学者对此问题的观点也不一致。有学者认为,船员的概念以“配乘于船舶上或在船上任职”为构成要件<sup>3</sup>,岸基人员在工作条件、环境风险等诸多方面与船员相比有较大区别,不宜将岸基人员直接定性为公约意义上的船员,而定性为船公司的普通管理人员更为适宜。<sup>4</sup>上海海事大学的王国华教授则认为,若无人船由岸基控制人员辅助操控,岸基控制人员承担与船员同等责任,基于“权责对等”的原理,则应在一定程度上认可其船员的法律地位。<sup>5</sup>此外,赋予岸基控制人员船长的法律地位,要求岸基控制人员具备与船长相当的良好船艺,也可以促使其在面对无人船碰撞危险和紧迫局面时正确地应对。<sup>6</sup>

当然,即便将岸基控制人员认定为船员,岸基控制人员与传统船舶上的船员也有很大的不同。两者工作的地点不同,所面临的风险、需要掌握的技能、过失或过错可能招致的结果等各方面都有所区别。因此,《船员条例》中对于船员的资格、

<sup>1</sup> Eric Van Hooydonk. The law of unmanned merchant shipping - an exploration. *Journal of International Maritime Law*, 2014 (20): 413.

<sup>2</sup> Robert Veal, Michael Tsimplis. The integration of unmanned ships into the lex maritima. *Lloyd's Maritime and Commercial Law Quarterly*, 2017(2): 318.

<sup>3</sup> 王秀芬. 船员之法律概念辨析. *社会科学家*, 2010(11): 85.

<sup>4</sup> 郑世江. 论无人运输船的法律地位与公约适用. *法制与社会*, 2019(05): 207.

<sup>5</sup> 王国华,孙誉清. 无人货物运输船的法律冲突及协调. *中国航海*, 2019, 42(01): 79.

<sup>6</sup> 王国华,孙誉清. 无人船碰撞相关的责任. *上海海事大学学报*, 2019, 40(02): 126.

职责、培训等各方面的规定都无法直接适用。

因此,本文建议《船舶最低安全配员规则》中增加免除适用的条款,只要无人船在技术上能够满足国内外法律规定的的安全标准,足以保证海上航行安全,就不需要受“最低安全配员”的限制。《船员条例》中关于船员的各项义务,也不能够直接适用于岸基控制人员。对于岸基控制人员与传统船员的共性部分(例如管理和驾驶船舶的职责)予以保留适用,而对于资格认定、培训等有区别的部分,应当增设条款予以单独规定。

## (二) 船舶登记与船舶国籍

《海上交通安全法》第5条规定:“船舶必须持有船舶国籍证书,或船舶登记证书,或船舶执照。”《船舶登记条例》第3条规定“船舶经依法登记,取得中华人民共和国国籍,方可悬挂中华人民共和国国旗航行;未经登记的,不得悬挂中华人民共和国国旗航行”,第49条规定“假冒中华人民共和国国籍,悬挂中华人民共和国国旗航行的,由船舶登记机关依法没收该船舶。中国籍船舶假冒外国国籍,悬挂外国国旗航行的,适用前款规定”,进一步强调了船舶应当依法进行登记并取得国籍。如上所述,无人船符合船舶的相关定义,因此当然也可以并且应当依法进行船舶登记,取得国籍航行。

《船舶登记办法》第38条规定:“船舶所有人申请船舶国籍,应当按照《中华人民共和国船舶登记条例》第十五条的规定提交有关材料。”《船舶登记条例》第15条分别规定了航行国际航线和国内航行船舶的船舶所有人申请船舶国籍所需提交的技术证书。依据交通运输部2017年1月10日发布并实施的《海事行政许可裁量基准》,船舶国籍证书的核发需要满足四个条件:(1)船舶已依法办理船舶所有权登记;(2)船舶具备适航技术条件,并经船舶检验机构检验合格;(3)船舶不具有造成双重国籍或者两个及以上船籍港的情形;(4)船舶国籍的登记人为船舶所有人。后两个条件为对船舶所有人行为的限制条件,不做讨论。而依照前两个条件,无人船如需获得船舶国籍,除了应当依法进行船舶登记以外,还需要具备适航技术条件并经船舶检验机构检验合格、核发相关的技术证书。目前,我国对于船舶的检验标准有《国内航行海船法定检验技术规则》《国际航行海船法定检验技术规则》等,而关于无人船检验的规则、规范只有中国船级社发布的《智能船舶规范》《无人水面艇检验指南》《自主货物运输船舶指南》,尚还缺乏专门针对无人船的具体法定检验技术规则。

《船舶登记条例》第7条规定:“中国籍船舶上应持适任证书的船员,必须持有相应的中华人民共和国船员适任证书。”因此,船舶上必须配备持有中国船员适任证书的船员似乎成为了船舶取得中国国籍的必要条件之一。<sup>1</sup>本文认为,此条规定是对在船船员作出持有适任证书的要求,也即若无在船船员则不需要持有相应的适任证书,此条款不是对在船船员人数的要求条款,不应当成为船舶取得中国国籍

---

<sup>1</sup> 王欣,初北平.研发试验阶段的无人船舶所面临的法律障碍及应对.中国海商法研究,2017,28(03):62.

的必要条件。而且,在上文所述的《海事行政许可裁量基准》规定的条件中,也没有将船员作为国籍取得的必要条件。

综上所述,本文建议中国尽快出台针对无人船的具体法定检验技术规则,避免无人船因无法通过船舶法定检验而被限制发展。

#### 四、中国《海商法》主要制度对无人船的应对思考

中国《海商法》主要调整船舶关系和海上运输关系,是与船舶相关的民事责任最重要的国内法源。本部分将分析中国《海商法》主要制度对无人船的适用性并提出应对建议。

##### (一) 船员

《海商法》第三章船员第31条规定:“船员,是包括船长在内的船上一切任职人员”,该条款明确规定船员为“船上”的人员。若严格适用此项条款,那么,对于遥控无人船来说,岸基控制人员不在船上,就不能被认定为是船员。但是,与此同时,岸基控制人员又确实履行着船员的职责,比如第35条所规定的“管理和驾驶”船舶的船长职责。因岸基控制人员不在船上工作,也就不会面临传统船舶上的船员所面临的海上特殊风险,尽管其又确实履行着船员的职责,但其是否可以与传统船员一样被一视同仁地予以保护,或者说应给予何种程度的保护是值得探究的。

本文认为,岸基控制人员所在的位置与面临的风险大小可能会是其薪资待遇等的影响因素,但是不应当影响岸基控制人员的船长身份。依据《船员条例》第4条规定:“本条例所称船长,是指依照本条例的规定取得船长任职资格,负责管理和指挥船舶的人员。”如若岸基控制人员取得相应的适任证书,并实际履行管理和驾驶船舶的船长职责,就应当取得船长的身份。因此,《海商法》第31条应当修改为:

“船员,是包括船长在内的船上一切任职人员以及实际履行管理和驾驶职责的岸基人员。”

##### (二) 海上货物运输合同

《海商法》第四章海上货物运输合同赋予了承运人“谨慎处理使船舶适航”的义务,而无人船的技术发展尚未成熟,该以何种标准确认船舶属于“适航”状态也是不确定的。比如,对于自控无人船,该以何种标准判断预设的程序是否足以妥善完成预设的航行任务?除此以外,承运人的免责事由中,船长、船员的管理和驾驶船舶的过失免责事由的适用性也值得探究。

对于自控无人船,没有所谓船长、船员的存在,也就没有必要再赋予承运人此项免责事由。而对于遥控无人船,可认定岸基控制人员具备船长的身份,因此承运人有可能适用航海过失免责。但是,一方面航海过失免责制度是一项古老而特殊的制度,随着科技的发展,人们对其争议也越来越大,《汉堡规则》和《鹿特丹规则》都废除了航海过失免责。据统计,中国在近30年的司法案例中,承运人主张适用航海过失免责的案件有18例,而成功享受到航海过失免责的仅有7例,包括1例因恶劣天气和驾驶过失等多种因素造成的事故,7个成果案例中承运人是中国船东

的仅有 1 例。<sup>1</sup>由此可见,随着科技的发展,航海过失免责在立法上有被废除的趋势,在司法实践中适用机会也很少且被严格适用,无人船作为高科技水平的船舶,也应该顺应趋势取消适用此项免责事由。另一方面,虽然可以认定岸基控制人员具备船长的身份,但是其实际工作地点不在船上,其直接管控的仪器、设备也不在船上,如若发生航海事故,更可能是无人船自身的产品缺陷所致。对于无人船这种高科技产品来说,产品缺陷与“适航”的相关性很大,承运人也更可能因为未能使船舶处于“适航”状态而不能享受此项免责。

因此,应尽早立法或修改法律确认无人船的“适航”标准,并取消无人船承运人的船长、船员管理和驾驶船舶的过失免责事由。

### (三) 船舶碰撞

根据《海商法》第八章船舶碰撞的相关规定,在《海商法》所调整的船舶碰撞关系中,如果碰撞一方船舶是《海商法》总则规定的船舶,另一方船舶可以扩大适用于非用于军事的或者政府公务的任何船艇。因此,不管无人船是作为船舶,还是作为与船舶碰撞的另一方主体,《海商法》关于船舶碰撞的相关规定总是适用于无人船的。

在考虑无人船碰撞问题时,首先必须明确的是,即使无人船技术发展迅速并能够大规模商用,有人船也不会被全部淘汰,在未来很长的一段时间内,会出现的是无人船与有人船并存的局面。在此前提下,无人船碰撞存在两种值得考虑的情况,一种是无人船与有人船的碰撞,另一种是无人船之间的碰撞。同时,无人船作为一种高智能的科技产品,除了适用本章关于船舶所有人过错责任的规定外,若因无人船的产品质量出现问题,还可能适用《侵权责任法》关于生产者和销售者无过错责任的相关规定。

在此前提下,应分不同情况确定碰撞船舶之间的赔偿责任:1.在无人船与有人船之间发生碰撞时,无人船适用严格责任原则,有人船适用过错责任原则,双方对第三方损失承担连带责任;2.在无人船和无人船之间发生碰撞时,对于第三方的损失,双方都适用严格责任原则,对外承担连带责任;对于双方船舶之间的损失,双方按照过错比例承担责任;3.在无人船发生碰撞时,无人船的生产者、销售者和船舶所有人对外承担连带责任,对内按各自的过错比例承担赔偿责任;4.无人船的所有人、经营人享有海事赔偿责任限制的权利,无人船生产者、销售者的责任承担适用《侵权责任法》的规定,不享有《海商法》中海事赔偿责任限制的权利。

### (四) 海难救助

根据《海商法》第九章海难救助第 174 条规定:“船长在不严重危及本船和船上人员安全的情况下,有义务尽力救助海上人命。”作为救助方,无人船不搭载船员,没有船员在船舶上,那么对于人命救助的相关条款是否还有必要适用呢?

---

<sup>1</sup> 张一祯,蒋正雄.关于废除《海商法》中过失免责制度之思考.华东政法大学学报,2019,22(05):165.

无人船国际工作组所设计的调查问卷第 3.3 问中提出了类似的问题。在收回的问卷中,绝大部分国家对无人船能否以“无人”作为不履行海上人命救助义务的抗辩理由持否定的态度,理由主要是无人船对人命救助的能力体现的是技术问题,无人船的设计者应当预见到无人船在海上可能需要对遇险人员提供救助的情形。持肯定态度的日本和英国则认为,救助义务主要是由船长而非船舶承担,且是处于能够提供援助位置的船长,排除了岸基控制人员的救助义务。<sup>1</sup>

海难救助的目的是尽最大努力应对海上风险,减少人命和财产损失,防止环境污染扩张。基于此种目的,无人船作为船舶的一种,应该在技术允许范围内履行救助义务。无人船履行救助义务的方法是多样的,例如可以利用船载的传感器拍摄、监测遇难人员和船舶的状况,为救助机构提供资料支援;也可以搭载小型遥控救生艇等救生用具,必要时发射出去履行救助义务。总之,无人船不应当被绝对地免除海难救助的义务,但是履行方式上可以适当变更。

无人船作为被救助方,关于财产救助和防止海洋环境污染的相关条款可以予以适用。但是,被救助方签订救助合同的当事人可能不再是船长,而可能是远程遥控船舶的岸基控制人或者船舶所有人自己。

### （五）共同海损

共同海损的形成前提,是船舶、货物和其他财产遭遇了共同危险,为了共同安全,船长有意地合理地采取措施排除共同危险。对于遥控无人船,船长的职责转移给岸基控制人员,尚还容易判断其是否是“有意地合理地”采取措施。问题在于,对于自控无人船,如何判断其是“有意地”采取措施的?如果不能做此项判断,共同海损制度对于自控无人船是否就不再适用?本文建议,在进行自控无人船的程序设计时,专门设计共同海损的相关程序版块,设定程序的启动条件,作为采取共同海损措施证明。

### （六）海上保险

无人船相较于传统船舶,海上风险也发生了变化。对于传统船舶来说,人为因素是海上事故最主要的原因。但是,无人船因为船员的转移或缺失,人为因素所导致的事故会减少。而与之相应的,由于无人船对于网络信息技术和自动化技术的高度依赖,网络风险会变得异常严峻。例如,黑客可能通过侵入船舶控制系统的方式挟持无人船,而不必通过控制船员的方式控制传统船舶。而黑客通过互联网控制无人船的行为性质目前却争议很大,事实认定的结果可能包括海盗、盗窃、捕获、扣押或是扣留。<sup>2</sup>这会使得无人船的投保方无所适从,也会使得看好无人船盈利能力的保险公司不敢轻易签订保险合同,承担相关风险。但是,正如 Lloyd 的首席执行官 Inga Beale 所言,问题不在于保险公司,而在于监管机构和国际法一致同意此

<sup>1</sup> Summary Of Responses To The CMI Questionnaire. <https://comitemaritime.org/work/unmanned-ships/>. 访问日期: 2019.11.13.

<sup>2</sup> 王国华,孙誉清. 21 世纪海盗:无人船海上航行安全的法律障碍. 中国海商法研究,2018,29(04):108.

项技术是安全的。如果经过研究、海上试验和市场整合，监管机构接受无人船技术的安全性，那么保险公司也能更有胆量去承担无人船技术发展中的风险。<sup>1</sup>

近些年，国际社会和中国对船舶网络安全也投入了极大关注。2015年12月，国际船级社协会（IACS）成立网络系统专业委员会（Cyber System Panel）监管网络安全；2016年初，波罗的海国际航运公会（BIMCO）发布全球首个船舶网络安全指南；2017年5月，IMO海上安全委员会在其第96届大会通过并随后发布了《船舶网络安全管理指南》通函；2017年7月，中国船级社发布了《船舶网络系统及安全评估指南》<sup>2</sup>；2018年5月1日，中国船级社制定的《智能集成平台检验指南（2018）》开始生效，其中对网络和数据要求进行了细化规定。可见，无人船的网络安全具备一定的制度保障，保险公司承担的无人船技术风险也会相应减少。

本文建议，应该研究确认通过网络侵入无人船行为的性质，并设置相应的投保项目，以分摊无人船发展过程中的网络风险。当然，保险公司也可以要求无人船网络安全系统需要满足的标准作为投保条件，例如要求投保的无人船的系统设计和公司网络安全管理需要符合中国船级社发布的《智能船舶规范（2020）》《船舶网络系统及安全评估指南（2020）》《智能集成平台检验指南（2018）》等的要求。

## 五、结论

无人船技术发展迅速，国际组织和各国都在积极探索、制定相关的规则和规范，以应对无人船技术带来的挑战。中国政府与相关行业也十分关注无人船问题，依照《智能船舶标准体系建设指南（征求意见稿）》，中国政府部门定下了在2025年基本形成智能船舶标准体系的任务目标。

在现行中国法下，无人船大体上是适用于船舶相关法律体系的。但是，由于立法之初没有进行相应的考量，部分具体的法律规则适用于无人船时存在困难，还存在相关标准、检验规范缺失等问题。对于海事管理类法律规则，一方面应当修改有瑕疵的规定，以将无人船纳入船舶法律体系中，例如修改“最低配员”的相关规定；另一方面还应当完善针对无人船的立法，比如制定无人船的具体法定检验技术规则。而对于海商法规则，则需要紧跟国际社会的无人船立法动态，对于无人船运输承运人的责任、船舶碰撞的归责原则、海难救助、相关网络风险保险和海盗行为等方面的问题进行研究，完善相关规定。

总体而言，无人船技术作为一项新兴的技术，中国政府部门为其制定了良好的政策、指南和规范鼓励其发展。无论国际社会还是各国政府在法律制度上也应跟上无人船技术的发展，为其提供法律保障，同时给无人船发展留有一定的容错和创新空间。

---

<sup>1</sup> Stephanie Guerra. Ready about, Here Comes AI: Potential Maritime Law Challenges for Autonomous Shipping, 30 U.S.F. Mar. L.J. 69 (2017): 84.

<sup>2</sup> 2020年3月1日，《船舶网络系统及安全评估指南（2020）》生效，对2017年版指南进行了修改

# Autonomous Ships in China: Policies and Regulations

HAN Lixin\* XIA Wenhao\*\*  
(Law School, Dalian Maritime University)

**Abstract:** The Chinese government and relevant industries have actively dealt with the challenges posed by autonomous ship technology and issued many important policies and regulatory documents. This paper studies the research and development policies, norms, standards and regulatory actions for autonomous ships in China. It is found that the current legal system of China is generally applicable to autonomous ships, but some rules ought to be amended and supplemented. In view of the problems with the application of China's maritime management legal rules and main system of maritime law to autonomous ships, this paper also offers certain relevant actions.

**Keywords:** autonomous ships polices regulations

## 0. Introduction

The technology of autonomous ships has evolved considerably in recent years. The world's first 10000-ton intelligent ship was certified by London Classification Society and put into service in December 2017. Norwegian shipping companies, Wilhelmsen Group and Kongsberg Group, established the first autonomous shipping company in the world in joint venture——“Massterly”, fully operational in August 2018. Japanese shipping company, Nippon Yusen Kaisha (NYK) published in its official website that they had successfully conducted the globally first maritime autonomous surface ship test according to relevant temporary guides from International Maritime Organization (IMO) in September 2019. In April 2020, Silver Origin, a cruise ship owned by Royal Caribbean Cruises Ltd of the Netherlands, successfully carried out the world's first remote control sea trial of a cruise ship.

In China, Asia's first, world's largest autonomous ship offshore test site ——Zhuhai Wanshan Intelligent Ship Offshore Test Site announced the opening, and the China Classification Society(CCS) awarded the test site service supplier certification on 1<sup>st</sup> December 2018. On December 15, 2019, JIN DOU YUN 0 HAO, China's first autonomous cargo ship, successfully completed the first autonomous cargo transportation on Dongao Island in Zhuhai . In May 2020, the construction of China's first autonomous container merchant ship, named ZHIFEI, began in Qingdao.

---

\* HAN Lixin (1967 - ), female, Han nationality, born in Qinhuangdao, Hebei Province, professor and doctoral supervisor of Law School of Dalian Maritime University, majoring in maritime law. E-mail: hanlixin@dmlu.edu.cn.

\*\* XIA Wenhao (1993 - ), male, Han nationality, born in Yancheng, Jiangsu Province, doctoral candidate of Dalian Maritime University, majoring in maritime law. E-mail: [xwh0150@dmlu.edu.cn](mailto:xwh0150@dmlu.edu.cn);

©THE AUTHOR AND MARINE LAW AND POLICY

In order to meet the challenges emanating from the technological development of autonomous ships, the international community and States have all been actively exploring, making and perfecting relevant regulations and standards. In terms of the rules and standards of international conventions, the IMO has constituted a working group on maritime autonomous surface ship (MASS). Defined and classified, MASS started combing and analyzing the relevant regulations and applicability of MASS, and prepared a trial guidelines for its operations. Moreover, the International Association of Classification Societies issued 12 proposals on ship network security. International Standardization Organization, International Electrotechnical Commission, International Telecommunication Union and so forth have all been initiated to make relevant standards for autonomous ships.

As a large shipping country, China has also devoted full attention to the development of autonomous ships, issuing relevant policies, regulations and guidelines to support the autonomous ships successively in recent 5 years. Meanwhile, the statutory rules are also under intense review. This essay introduces and discusses the research and development policies, regulations, standards and legal reactions related to Chinese autonomous ships.

## **1. Research and Development Policies and Current Relevant Standards of Autonomous Ships in China**

### **1-1. Rules for Intelligent Ships 2015 by CCS**

On March 1, 2016, *Rules for Intelligent Ships 2015* (*The 2015 Rules* in short) drafted by CCS officially came into effect. *The 2015 Rules* is the first rule of intelligent ship in the world.<sup>1</sup> It is an open rules, adopting goal-based standards method. In terms of function, *The 2015 Rules* divides the intelligent ship into six parts: intelligent navigation, intelligent hull, intelligent machinery, intelligent energy efficiency management, intelligent cargo management and intelligent integrated platform, and regulates the general requirements, functional notation, plans and documents, survey and test of each function in six chapters. CCS has also successively formulated *Guidelines for Surveys of Intelligent Machinery of Ships 2017*, *Guidelines for Surveys of Intelligent Integrated Platforms 2018*, *Guidelines for Surveys of Intelligent Energy Efficiency Management of Ships 2018*, *Guidelines for Surveys of Intelligent Cargo Management of Ships (Oil Tankers) 2018* and *Guidelines for Requirement and Security Assessment of Ship Cyber System 2020* to supplement and crystallize *The 2015 Rules*.

On March 1, 2020, *Rules for Intelligent Ships 2020* (*The 2020 Rules* in short) came into effect. Under the framework of the original rules, two more functions (remote control and autonomous operation) were added, and the corresponding general requirements, additional requirements for different functional notations, provision and performance of equipment, and survey and test requirements were provided in detail.

### **1-2. Inspection Guide for Unmanned Surface Vehicle 2018 by CCS**

*Inspection Guide for Unmanned Surface Vehicle 2018* (*The USV Guideline* in short) compiled by CCS formally came into force on January 1, 2018. *The USV Guideline* proposes requirements in respect of class survey, general objective and function requirement, communication system, control system, vehicle body, marine engine,

---

<sup>1</sup> Ma Jinxing, 'Artificial Intelligence Ship Leads Reform of International Maritime Regulation System', China Ocean News, 2019-10-08.



electrical engineering, navigation and signal equipment, and endowing different additional marks on account of different navigation mode (autonomous voyage, remote control) and distance from the shore. On August 1, 2018, the first change notification of *The USV Guideline* came into effect, adding classification characters, additional marks and examination requirement.

*The USV Guideline* only applies to the design, building and examination of vehicles greater than or equal to 5 metres but less than 20 metres length, vehicles beyond such scale could be executed by reference. *The USV Guideline* covers each stage including drawing review, product inspection and post construction inspection and consider respectively on account of the 3 parts of autonomous surface vehicle. That comprises communication system, control system and platforms (containing vehicle body, marine engine, electrical engineering, navigation and signal equipment) to conduct risk assessment and propose specific safety technical requirements.

### **1-3. Guidelines for Autonomous Cargo Ships 2018 by CCS**

On October 1, 2018, *Guidelines for Autonomous Cargo Ships 2018*, drafted by CCS, became effective. The guideline applies goal-based standards method. Toward covering technical requirements of autonomous ships of degree 3 and 4<sup>1</sup>, the guideline provides goal, functional requirements, prescriptive requirements to achieve functions and survey and test requirements. Chapters include: situation awareness, navigation control, machinery installations, mooring and anchoring, electrical installations, communication and signal equipment, hull construction and safety, fire-fighting, environmental protection, ship security, remote operation center, cyber security, etc.

### **1-4. Intelligent Ship Development Action Plan 2019-2021**

*Intelligent Ship Development Action Plan 2019-2021* (*Ship Development Action Plan* in short) was jointly issued by the Ministry of Industry and Information, the Ministry of Transport and State Administration of Science, Technology and the Industry for National Defense on December 27, 2018, which provides comprehensive instructions for the development plan of intelligent ship, ranks the establishment of intelligent ship standard system as action objective and key task, and explicitly proposes to research and study Construction Guidelines for intelligent ship code and standard system.

*Ship Development Action Plan* analyses and judges current development with intelligent ship and indicates that global intelligent ship is still explored and developed at a primary stage. Hereon, China shall accelerate the development of intelligent ship industry and seize the development highland of global intelligent ship industry. *Ship Development Action Plan* clearly puts forward to, after 3 years, form top development project of China intelligent ship, preliminarily establish intelligent ship code standard system, break through core technologies including navigation IntelliSense and autonomous berthing and disdocking, etc., finish developing relevant key intelligent equipment system, realize typical sites pilot demonstration of remote control and autonomous voyage and other functions, expand the demonstration and promotion of typical intelligent ship “One Platform + N intelligent application”, preliminarily form the

---

<sup>1</sup> In order to facilitate the regulatory scoping exercise of MASS, the Maritime Safety Committee of IMO divides MASS into four autonomy degrees: 1. Ship with automated processes and decision support; 2. Remotely controlled ship with seafarers on board; 3. Remote controlled ship without seafarers on board; 4. Fully autonomous ship.

intelligent ship comprehensive test and verification capability of virtual and reality combination, shore and sea integration; furthermore to keep China's development of intelligent ship up with advanced global standards..

### **1-5. Action Plan for Promoting Intelligent Transformation of Ship Grand Assembling and Construction 2019-2021**

On December 27, 2018, the Ministry of Industry and Information Technology (MIIT) and the State Administration of Science, Technology and the Industry for National Defense jointly issued the *Action Plan for Promoting Intelligent Transformation of Ship Grand Assembling and Construction 2019-2021* (*The Transformation Action Plan* in short). *The Transformation Action Plan* provides a comprehensive guidance for the development planning of intelligent transformation of ship assembly, and sets a main goal of initially establishing a technical innovation system and standard system for ship intelligent manufacturing, to speed up the improvement in shipbuilding technology.

*The Transformation Action Plan* puts forward 15 key tasks in five aspects and stipulates five key columns. The five aspects include: overcoming the key common technology and equipment weaknesses of intelligent manufacturing; consolidating the foundation of intelligent manufacturing; promoting the full three-dimensional digital design; accelerating the construction of intelligent workshop; and promoting the digital integration and service of shipbuilding. The five key columns include: key research and development of critical basic technologies for ship intelligent manufacturing; key research and development of weak equipment for ship intelligent manufacturing; key construction of shipyard information infrastructure; key construction of ship intelligent manufacturing standard system; and key emphasis on promoting full three-dimensional digital design.

### **1-6. Guidance on the Development of Intelligent Shipping**

On May 9, 2019, the Ministry of Transport and other seven departments jointly issued *Guidance on the Development of Intelligent Shipping* (*Intelligent Shipping Guidance* in short), which clarified the overall requirements, main tasks and safeguard measures for the cultivation and development of intelligent shipping.

According to *Intelligent Shipping Guidance*, by the end of 2020, the top-level design of intelligent shipping development will be basically completed; by 2025, a number of key technological challenges restricting the development of intelligent shipping will be tackled to become a global intelligent shipping development and innovation center; by 2035, the core technology of intelligent shipping will be comprehensively mastered, and the technical standard system of intelligent shipping will be relatively perfect; by 2050, a high-quality intelligent shipping system will be formed. *Intelligent Shipping Guidance* defines ten main tasks, covering top-level design, technology application and innovation, safeguard measures, regulations and supervision mechanism, personnel training and other aspects.

### **1-7. Guidance for the Construction of Standard System of Intelligent Ship (Draft for Comments)**

In September 12, 2019, the MIIT of PRC released *Guidance for the Construction of Standard System of Intelligent Ship (Draft for Comments)* (*Intelligent Shipping Guidance* in short). On April 30, 2020, the equipment industry department of MIIT and standards and technology department of the State Administration for Market Regulation issued a new version of *Intelligent Shipping Guidance*. Both Guidelines stipulate the overall

requirements, system framework, construction content and organization implementation of intelligent ship standard construction.

According to the new *Intelligent Shipping Guidance*, the construction goal is divided into two stages, each stage has different objectives. The first stage is from 2020 to 2021: It is required to form support for basic common standards such as definition of terms, classification of intelligent ships, and attain breakthroughs in the application standards of key technologies of intelligent ships. Equally, intelligent ship design, intelligent ship borne systems and equipment, and intelligent ship test and survey standards should meet the needs of real ship construction. The second stage is from 2022 to 2025, which requires the basic commonness of intelligent ships, application of key technologies, intelligent ship design, intelligent shipborne systems and equipment, formation of intelligent ship testing and verification standard system, improvement in shore-based service and operation management standards, and the further improvement in standard system.

The new *Intelligent Shipping Guidance* divides the framework of the standard system into three levels: the top level of the standard system, seven parts and 38 specialties and fields. The construction content includes seven parts : (1) basic common standards; (2) key technology application standards; (3) intelligent ship design standards; (4) intelligent shipborne system and equipment standards; (5) intelligent ship test and verification standards; (6) shore based service standards; (7) operation management standards.

Through the above contents of policy documents, specifications and guidance, it can be realized that the relevant departments of the Chinese government attach great importance to the development of intelligent ship, stressing the need to have the top-level design, focusing on the common research and application of key technologies. The test field, ship inspection specifications, standard system construction or other aspects are all fully guaranteed. To a certain extent, the formulation of policies, norms and standards is ahead of the development and design of autonomous ships.

## **2. The Legal Status of Autonomous Ships under Chinese Law**

At present, there is no special law on autonomous ships, whether domestic legislation or international treaties. In addition to China's participation in international conventions on marine pollution prevention , safety and civil liability(e.g. UNCLOS 1982 、MARPOL73/78、STCW、SOLAS、MLC、OPRC 1990、CLC、BANKER CONVENTION, etc.), the management class law is mainly related to *Maritime Traffic Safety Law of the People's Republic of China*, *Marine Environment Protection Law of the People's Republic of China*, *Regulations of the People's Republic of China on the Prevention of Vessel-Induced Sea Pollution*, *Regulations on registration of vessels*, *Regulation of the People's Republic of China on Seamen*, *Regulations of the People's Republic of China Governing Survey of Ships and Offshore Installations and Vessel Inspection Administration Regulation*, etc.; The law relating to the civil liability of ship operation is mainly *Maritime Code of the People's Republic of China*. Does China's current law apply to autonomous ships? This essentially depends on whether the relevant "ship" concept in Chinese law applies to autonomous vessels.

### **2-1. The Application of Maritime Management Laws to Autonomous Vessels**

The international working group on unmanned vessels of CMI, describes unmanned vessels as "those which are capable of controlled movement over water without any crew on board". According to this definition, the following four elements can be summarized: (1) on the water; (2) movable; (3) movement is controlled; (4) no crew. According to the way of control, autonomous ship can be divided into remote-controlled autonomous ship

and self-controlled autonomous ship (fully autonomous ship). The remote-controlled autonomous ship is a shore-based controller that controls the movement of the ship remotely, while the fully autonomous ship moves itself without manual intervention in accordance with pre-written procedures. Compared with ordinary ships, the more controversial issue is whether the absence of a crew member on board affects the formation of a "ship".

Article 50 of the *Maritime Traffic Safety Law of the People's Republic of China* stipulates that "ship" means "all kinds of displacement or non-displacement vessels, rafts, seaplanes, submersibles and mobile platforms". "Vessels" as defined in section 56 of the *Regulations on Registration of Vessels* are "all types of motor, non-motor vessels and other marine mobile devices, other than life craft rafts and craft rafts of less than 5 meters in length"; Article 29 of the *Regulations of the People's Republic of China Governing Survey of Ships and Offshore Installations* stipulates: "vessels refer to all types of displacement or non-displacement vessels, boats, seaplanes, submersibles and mobile platforms". The above definition of "ship" does not include the requirement of carrying a crew. Therefore, from the perspective of literal interpretation, whether it is a remote-controlled autonomous ship or a fully autonomous ship, whether or not the crew is on board. Accordingly, "autonomous ship" should belong to the adjustment object of the above laws and regulations.

In the questionnaire issued by CMI, question 1.1 asks that would an unmanned cargo ship in excess of 500 gross ton constitute a "ship" under your national merchant shipping law? Apart from Croatia, which gave a negative answer, 18 other countries, including China, considered it to be a ship.<sup>1</sup> Reasoning from the above analysis, since the autonomous ship constitutes a ship, China's current maritime management law should apply to autonomous ship. However, at the same time, we should also pay attention to the problems with the application of domestic maritime management laws for autonomous vessels, including but not limited to: limitation of ship manning requirements; restrictions on ship manning requirements; crew qualifications, crew disability compliance; difficulties in obtaining the nationality of the ship; and lack of specific technical rules for ship inspection.

## **2-2. Application of Civil Liability Law to Autonomous Vessels**

*Maritime Code of the People's Republic of China(CMC)* is the most important source of civil liability related to ships, among which article 3 stipulates: "ships as used in this Law" refers to ships and other marine mobile devices, with the exception of ships used for military and government services and small vessels of less than 20 gross tons. The legislative plan of the standing committee of the 13th National People's Congress (NPC) was released on September 7, indicating that 47 types of legislative items need to be submitted for deliberation when conditions are ripe for urgent work. However, the definition of "ship" has not been changed in the draft amendment to the maritime law initiated by the Ministry of Transport. Therefore, like maritime management laws, there is no requirement for the crew to be equipped in the definition of "ship" and autonomous ships meet the definition of ship in *CMC*.

## **3. Thoughts on the Reaction of Chinese Maritime Management Legal Rules to Autonomous Ships**

---

<sup>1</sup> Summary Of Responses To The CMI Questionnaire. <https://comitemaritime.org/work/unmanned-ships/>.Date of visit: 2019.11.13.

After the above analysis, although the autonomous ship belongs to the ship, the current direct application of the maritime management law will cause some discomfort. At present, most of the vessels in the trial navigation phase are remote-controlled autonomous vessels. Fully autonomous vessels are difficult to commercialize on a large scale for a long time. Even some people believe that we may never see fully autonomous ocean freighter.<sup>1</sup> For a long time in the future, it is more likely that there will be a situation where remotely controlled autonomous vessels coexist with manned vessels. Therefore, this paper mainly proposes the countermeasures for the Chinese maritime management legal rules for remote-controlled autonomous ships, and appropriately reserves space for the development of fully autonomous ships.

### 3-1. Crew and Crew Duties

In the traditional shipping field, cargo ships are equipped with crew sailing. Chinese domestic law also requires ships to be equipped with a sufficient number of crew members. For example, Article 6 of the *Maritime Traffic Safety Law* stipulates that “ships should be equipped with qualified crew members sufficient to ensure the safety of ships in accordance with the standard quota”. This raises a question: from the perspective of system interpretation, does the clause mean that the provision or ability to equip the crew is a component of the ship?

We should look at this issue in combination with the two qualifications of “standardized quota” and “sufficient to ensure ship safety”. “Standardized quota” means that the number of crew members varies according to different situations, as stipulated in Article 6 of the *Minimum Safe Manning Rules for Ships*: “The minimum safe manning standard for ships shall be considered in consideration of the type and tonnage of the ship, technical conditions, main propulsion power, flight area, voyage, sailing time, navigation environment and crew duty, rest system and other factors.” Considering the special type of ship the autonomous ship is, the advanced technical level, and no need to take into account the advantages of the crew's rotation, it is understandable to reduce the number of crew members when determining the manning of the autonomous ship until the crew is not present. “Ensure the safety of the ship” points out the purpose of the crew, and this is the advantage of the autonomous ship. According to statistics, it is generally believed that about 80% of marine accidents are caused by human factors. According to the “Annual Report on Maritime Casualty Accidents of 2019” recently issued by the European Maritime Safety Administration, 65.8% of the total of 4104 accidents analyzed during the investigation were attributed to mistakes.<sup>2</sup> Autonomous ship technology eliminates interference from human factors, and is more conducive to ensuring the safety of ships.

At the same time, due to the absence of the crew, the provisions of the Crew Regulations on the qualification of crew members, crew duties, crew training, etc. are also not applicable. For the shore-based controllers of remote-controlled autonomous ships, whether they belong to the crew, there is no international conclusion.

From the perspective of international law, the current STCW Convention applies only

---

<sup>1</sup> Wo Shen admiralty. Opinion: Why do we never see a completely autonomous ocean freighter? [https://mp.weixin.qq.com/s?\\_\\_biz=MjM5NTQ3MzYxMA==&mid=2650708166&idx=1&sn=550b5f8b6db5ad738febf0150b99e6bb&chksm=befdc963898a407594a5dde0fd08e736bc2d6d4e6d9213f3378ddf08d08c81633cc41c07420d#rd](https://mp.weixin.qq.com/s?__biz=MjM5NTQ3MzYxMA==&mid=2650708166&idx=1&sn=550b5f8b6db5ad738febf0150b99e6bb&chksm=befdc963898a407594a5dde0fd08e736bc2d6d4e6d9213f3378ddf08d08c81633cc41c07420d#rd). Date of visit: 2019.11.13. The views in this article are derived from: CDR David Dubay, USCG Maritime Security, Russia, Arctic.

<sup>2</sup> Annual Overview of Marine Casualties and Incidents 2019, published in the maritime service network CNSS, Date of visit: 2019.11.11.

to crew members on board ships, but it may also be revised to cover shore-based control personnel.<sup>1</sup> The IMO Maritime Autonomous Navigation Ship Inter-Working Group meeting held in September 2019 discussed the definition of the crew in the STCW Convention. The Working Group believes that if the shore-based controller is identified as a crew member and the STCW Convention is applied, the terms of the ship must be discussed again. Eric Van Hooydonk believes that for shore-based control personnel who assume overall responsibility for autonomous ship navigation, the definition that the “captain” has the highest level of position in the ship's navigation is broad enough to cover shore-based control personnel. At the same time, Hooydonk mentioned that, on the one hand, shore-based control personnel are exempted from the burden of the international environment, physical health, safety risks, discipline, long-term work on board and away from home, family and social life. Therefore, it is difficult to find effective reasons to incorporate it into the adjustment of maritime law; on the other hand, shore-based controllers also need to have good judgment, communication, decision-making ability and necessary nautical knowledge and information technology knowledge like traditional captains to take responsibility for transportation, collision avoidance, pollution prevention and so on.<sup>2</sup> Some scholars believe that even in traditional ships, although the captain is responsible for the overall navigation, the captain is not always in the cab. However, the captain does have an important security role on the ship because the coastal state has the object of the enforcement of criminal liability. The shore-based control personnel of the autonomous ship can be identified as the captain, but the issue of the criminal liability must be resolved.<sup>3</sup>

At the domestic law level, the International Maritime Committee issued a questionnaire to investigate whether the shore-based controllers constitute the “Captain” (question 1.4.1) and the “Crew” (question 1.5) of the domestic law. According to the survey results, only 3 out of the 19 countries surveyed (including China) defined the “captain” as a person on board, and the maritime law associations in 6 countries indicated that they believed that the chief shore-based controller might constitute the captain. The Maritime Law Association of 10 countries (including China) replies that they have the definition of “crew” in its domestic law, and apart from Brazil which stipulates that the crew is clearly required to be on board, the Maritime Law Association of 8 countries (including China) considers that the definition of the crew cannot cover the shore-based controllers. It is obvious that the definition of “crew” and “captain” in domestic laws is quite large, which results in different legal status of shore-based control personnel in various countries.

Domestic scholars also have inconsistent views on this issue. Some scholars believe that the concept of the crew is composed of “equipped for the ship and employed in the ship”,<sup>4</sup> the shore-based personnel have a big difference with the crew in terms of working conditions and environmental risks. It is not appropriate to directly define the shore-based personnel as crew members in the sense of the Convention, but more appropriate to define

---

<sup>1</sup> Allen, Craig H, ‘Determining the legal status of unmanned maritime vehicles: formalism vs functionalism’ (2018) 49 *Journal of Maritime Law and Commerce* p 489.

<sup>2</sup> Eric Van Hooydonk, ‘The law of unmanned merchant shipping - an exploration’ (2014) 20 *Journal of International Maritime Law* p 413.

<sup>3</sup> Robert Veal, Michael Tsimplis, ‘The integration of unmanned ships into the lex maritima’ (2017)2 *Lloyd's Maritime and Commercial Law Quarterly* p 318.

<sup>4</sup> Wang Xiufeng, ‘The analysis of the Legal Concept of Seafarers’ (2010)11 *Social scientist* p 85.

them as the general management personnel of the shipping company.<sup>1</sup> Professor Wang Guohua of Shanghai Maritime University believes that if the autonomous ship is controlled by the shore-based control personnel, the shore-based control personnel bear the same responsibility as the crew. Based on the principle of “rights being equal to liabilities”, the legal status of the crew should be recognized to some extent.<sup>2</sup> In addition, giving the shore-based control personnel the legal status of the captain requires them to have a good boat skill comparable to that of the captain, and could also promptly respond to the danger and urgency of the collision of the autonomous ship.<sup>3</sup>

Of course, even if the shore-based controller is identified as a crew member, the shore-based controller is quite different from the crew on the traditional ship. The two are in different jobsites, and the risks they face, the skills they need to master, the consequences of negligence or fault, etc. are also quite different. Therefore, the provisions of the Crew Regulations on the qualifications, duties, training and other aspects of the crew cannot be directly applied.

Therefore, this paper proposes to add the exemption clause in the "Ship Minimum Safe Manning Rules". As long as the autonomous ship can technically meet the safety standards stipulated by domestic and foreign laws and it is enough to ensure the safety of maritime navigation, the “minimum safe manning” is no longer required.

The obligations of the crew in the Crew Regulations cannot be directly applied to shore-based controllers. For the common parts of shore-based control personnel and traditional crew members (such as the duties of managing and driving ships), reservations shall be applied, and for differentiated parts such as qualifications and training, additional provisions shall be made separately.

### 3-2. Ship Registration and Nationality

Article 5 of the *Maritime Traffic Safety Law* stipulates: "a ship must hold a certificate of its nationality, or a certificate of its registration, or a ship's license." Article 3 of the *Regulation on Vessel Registration* stipulates that "only when a ship which has been registered according to law and acquired the nationality of the People's Republic of China can sail under the national flag of the People's Republic of China"; Article 49 provides that "those who sail under the flag of the People's Republic of China while pretending to be the nationality of the People's Republic of China shall be confiscated by the ship registration authority according to law." The provisions of the preceding paragraph shall be applied to vessels of Chinese nationality that sail under the flag of a foreign country while passing themselves off as foreign nationality, further emphasizing that vessels shall be registered according to law and acquire nationality. As mentioned above, an autonomous ship meets the relevant definition of ship, so it absolutely could and should be registered as a ship which can obtain nationality for navigation in accordance with the law."

Article 38 of the *Regulation on Vessel Registration* stipulates that "shipowners who apply for ship nationality shall submit relevant materials in accordance with article 15 of the *Measures of the People's Republic of China for the Registration of Vessels*". Article 15

---

<sup>1</sup> Zheng Shijiang, 'On the Legal Status of Unmanned Vessels and the Application of the Convention'(2019)05 *Legal system and society* p 207.

<sup>2</sup> Wang Guohua, Sun Yuqing, 'The legal conflict and coordination of unmanned cargo carriers'(2019)01 *Chinese navigation* p 79.

<sup>3</sup> Wang Guohua, Sun Yuqing, 'The responsibility related to unmanned collision'(2019)02 *Journal of Shanghai Maritime University* p 126.

of the regulations on the registration of ships respectively stipulates the technical certificate required by the shipowner to apply for the nationality of a ship for international and domestic navigation. According to the *Maritime Administrative Licensing Discretion Benchmark* issued and implemented by the Ministry of Transport on January 10, 2017, the issuance of the ship's nationality certificate shall meet four requirements : (1) the ship has registered its ownership subject to law; (2) the ship has the seaworthiness in technical conditions and passed the inspection of the ship inspection institution; (3) the ship does not have any circumstances that cause dual nationality or more than two ports of registration; (4) the registrant of the nationality of the ship shall be the owner of the ship. The last two conditions are the restrictions on the behavior of the ship owner and shall not be discussed. According to the first two conditions, if an autonomous ship needs to obtain the nationality of a ship, it shall not only register the ship according to law, but also have the seaworthiness in technical conditions, pass the inspection of an authorized institution and issue the relevant technical certificate. Currently, China's inspection standards for ships include *Technical Rules for Statutory Survey on Seagoing Vessels Engaged in Domestic Voyage* and *Technical Rules for Statutory Survey on Seagoing Vessels Engaged in International Voyages*, but the inspection standards for autonomous ships are absent. Though CCS has issued *Rules for Intelligent Ships*, *the USV Guideline* and *Guidelines for Autonomous Cargo Ships*, they cannot be seen as legal basis used for statutory survey.

Article 7 of the *Regulation on Vessel Registration* stipulates that "seafarers of Chinese nationality who are required to hold certificates of competency must hold corresponding certificates of competency of seafarers of the People's Republic of China". Therefore, it seems to be one of the necessary conditions for a ship to acquire Chinese nationality that the ship must have crew members who hold Chinese certificates of competency.<sup>1</sup> What this paper argues is pursuant to the crew on board a ship to hold certificates of competency requirements, also when no crew on board a ship, there is no need for the corresponding certificate of competency. Hence, the provisions is not about the number of crew on board a ship, which means that it is not necessary for a ship to have a Chinese nationality. Meanwhile, as mentioned in the *Maritime Administrative Licensing Discretion Benchmark* above, the seafarer is not regarded as a necessary condition for obtaining nationality.

To sum up, this paper suggests that China promulgates specific technical rules of statutory survey on autonomous vessels as soon as possible to avoid limiting the development of autonomous vessels.

#### **4. Thoughts on the Reaction of Main Systems of Chinese Maritime Code to Autonomous ships**

*Chinese maritime code* mainly regulates ship and maritime transport relations, which is the most important source of domestic law for civil liability related to ships. This part will analyze the applicability of the main system of *Chinese maritime code* to autonomous vessels and put forward some suggestions.

##### **4-1. Seafarers**

Article 31 of the seafarers in chapter III of the *Chinese Maritime code* stipulates that "the seafarers are all the officers of the ship including the master", which clearly stipulates that the seafarers are the staff working "on the ship". If this clause is strictly applied, the

---

<sup>1</sup> Wang Xin, Chu Beipin, 'Legal barriers confronted by unmanned ships under trialing and reaction'(2017)03 *Chinese Journal of Maritime Law* p 62.



shore-based controller cannot be regarded as a crew of the ship if he is not on board. At the same time, however, shore-based controllers do perform the duties of the crew, such as the master's duties of "managing and steering" a ship, as stipulated in article 35. Since shore-based controllers do not work on the ship, they do not encounter the special risks at sea faced by the crew of traditional ships. Although they do perform the duties of the crew, it is worth exploring whether they can be equally protected as the traditional crew, or to what extent they should be protected.

According to this paper, the location and risk faced by shore-based controllers may be influencing factors of salary, but the captain's identity of shore-based controllers should not be affected. According to article 4 of the *Regulation of the People's Republic of China on Seamen*: "the master of the ship referred to in these regulations shall be the person who, in accordance with the provisions of these regulations, is qualified as a master and is responsible for the management and command of the ship." If shore-based controllers obtain appropriate certificates of competency and actually perform the duties of a master in the management and navigation of a ship, they shall acquire the status of a master. Therefore, article 31 of the maritime law should be amended: "seafarers shall be all personnel on board, including the master, and shore-based personnel who actually perform the duties of management and navigation."

#### 4-2. The Contract of Carriage of Goods by Sea

The contract of carriage of goods by sea in Chapter IV of the *Maritime Code* maintains that the obligation of the carrier is "prudent handling to make the ship seaworthy". However, as the technology of autonomous vessels has not yet matured, it is uncertain what kind of standard should be adopted to confirm that the ship belongs to the "seaworthy" status. For instance, for fully autonomous vessels, what criteria should be used to determine whether the preset program is sufficient to properly complete the preset navigation task? In addition, it is also worth exploring the applicability of the exemption from liability for the management of the captain and crew, and the negligence of the navigation of the ship.

For the fully autonomous ship, there is no so-called captain and crew, so it is not necessary to give the carrier this exemption. As for the remote-controlled autonomous ship, the shore-based controller can be identified as the captain, so the carrier may be entitled to exempt from navigation negligence. However, on the one hand, the liability exemption system for maritime negligence is an ancient and special system. With the development of science and technology, people more often have disputes about it. *Hamburg Rules* and *Rotterdam Rules* have abolished the liability exemption for maritime negligence. According to statistics, China's judicial cases in the past 30 years, registered carrier claims of nautical fault exemption in 18 cases, while nautical fault exemption success is only 7 cases, including 1 case for bad weather and driving errors caused by many factors such as accidents. Only 1 out of the above 7 cases the carrier is Chinese ship owner.<sup>1</sup> Alternatively, with the development of science and technology, nautical fault exemption has a tendency to be abolished in the legislation, the application of the exemption is rarely strict in practice. Autonomous ship as a high-tech that should apply the exemption and comply with the trend. On the other hand, although shore-based controllers can be identified as the captain, their actual work place is not on the ship, and the instruments and equipment directly controlled by them are not on the ship. If there is a maritime accident, it is more

---

<sup>1</sup> ZHANG Yizhen, JIANG Zhengxion, 'Reflections on Abolition of Fault Exemption System in Chinese Maritime Code' (2019)05 *ECUPL Journal* p 165.

likely to be caused by the product defect of the autonomous ship itself. For such high-tech products as autonomous ship, the product defect is closely related to "seaworthiness", and the carrier is more likely to fail in ensuring the "seaworthiness" of the ship hence, cannot enjoy this exemption.

Therefore, legislation or amendment should be made as soon as possible to confirm the "seaworthiness" standard of autonomous vessel, and cancel the exemption of captain and crew management and ship navigation of autonomous vessel carrier.

#### **4-3. Collision of Ships**

According to the relative regulations of Collision of Ships in Chapter 8 of the *Chinese Maritime Code*, in the relationship of collision of ships if one party of the collision is the ship regulated in the General Provisions of the *Code*, the other party can be extended to any ship that is not used for military or public purposes. Therefore, regardless of whether an autonomous ship is acting as a ship or as the other party that collides with the ship, the relevant provisions of the *Code* on ship collisions are always applicable to autonomous ships.

When considering the collision problem of autonomous ships, it must first be clear that even if the autonomous ship technology develops rapidly and can be commercialized on a large scale, the manned ships will not be completely eliminated. For a long time into the future, what will happen is a situation where autonomous ships coexist with manned ships. Under this premise, there are two situations worth considering in the collision of autonomous ships. One is the collision between autonomous ships and manned ships, and the other is the collision between autonomous ships. At the same time, as a highly intelligent technology product, for autonomous ships, in addition to applying the provisions of this Chapter on the fault liability of ship owners, if there is a problem with the quality of the autonomous ships, the regulations of no-fault liability of producers and sellers in *Chinese Tort Liability Law* may also apply.

Based on the premise stated earlier, the liability for collision between ships should be determined according to different situations: 1. When a collision occurs between an autonomous ship and a manned ship, the autonomous ship applies the principle of strict liability, and the manned ship applies the principle of fault liability, both parties bear joint and several liability for losses of any third party; 2. In the event of a collision between an autonomous ship and an autonomous ship, both parties shall apply the principle of strict liability to the loss of the third party, and shall bear joint and several liability; for loss of both parties, the two parties shall bear the responsibility according to the proportion of fault; 3. In the event of a collision of an autonomous ship, the producer, seller and owner of the autonomous ship shall bear joint and several liability, and they shall be liable for compensation according to their respective fault proportions; 4. The owner and operator of the autonomous ship shall have the right to limit their liability for maritime claims, and the responsibility of the producer and seller of the autonomous ship shall be subject to the provisions of the *Tort Liability Law* and shall not enjoy the right to limit their liability for maritime claims in the *Chinese Maritime Code*.

#### **4-4. Salvage at Sea**

According to Chapter 9 Article 174 of *Chinese Maritime Code*: "Every master is bound, so far as he can do so without serious danger to his ship and persons on board, to render assistance to any person in danger of being lost at sea" As the salvor, the autonomous ship is not equipped with crew member. Since there is no crew member on the ship, is it necessary to apply the relevant provisions on lifesaving?

Question 3.3 of Summary of Responses to the CMI Questionnaire raised a similar question. The majority of MLAs stated that whereas the mere fact that the ship is unmanned does not discharge the master from providing assistance to persons in distress, the fact that the ship is unmanned may de facto limit the scope of the duty since it would be limited to what is inter alia technically possible; the designer of unmanned ships should have foreseen the situation that unmanned ship at sea has to provide assistance to person in distress. Japan and the United Kingdom, which have a positive attitude, believe that as the obligation is channeled to the master rather than the ship, and the master is the one who can provide assistance, eliminating the obligation of shore based remote controller.<sup>1</sup>

The purpose of salvage at sea is to do its utmost to deal with marine risks, reduce human and property losses, and prevent environmental pollution from expanding. For this purpose, autonomous ships, as a type of ship, should fulfill their rescue obligations within the limits of the technology. There are various methods for autonomous ships to fulfill their salvage obligations. For example, they can use the sensors on board to detect and monitor the situation of the victims and the ships, and provide information support for the salvage agencies. They can also be equipped with life-saving appliances such as small remote-controlled lifeboats and launch them if necessary to fulfill the obligation of assistance. In short, the autonomous ship should not be absolutely exempted from the obligation of salvage at sea, but the manner of performance can be appropriately changed.

As a rescued party, the relevant provisions on property relief and prevention of marine environmental pollution can be applied to autonomous ships. However, the party signing the salvage contract by the salvage party may no longer be the master, but may be the shore-based controller of the remote-controlled ship or the ship owner himself.

#### **4-5. General Average**

The premise for general average is that when the ship, goods or other property is involved in a common maritime adventure, the sacrifice or expenditure is intentionally and reasonably made or incurred by the master for the common safety and the purpose of preserving from peril. For remote-controlled autonomous vessels, the master's duties are transferred to shore-based control personnel, and it is still easy to judge whether it is "intentionally and reasonably" to take measures. The question is, how to judge that it is "intentionally" taking measures for a fully autonomous ship? If this judgment cannot be made, does the general average system no longer apply to fully autonomous ships? This paper suggests that when designing a fully autonomous ship, the relevant program sections of the general average shall be designed, and the starting conditions of the program shall be set as proof of the common average measures.

#### **4-6. Marine Insurance**

Compared with traditional ships, maritime perils of autonomous vessels have also changed. For traditional ships, human factors are the main cause of maritime accidents. However, the number of human-caused accidents on autonomous vessels will decrease due to the decrease or absence of crew. Correspondingly, due to the high dependence of autonomous ship on network information technology and automation technology, the network risk could become extremely serious. For example, a hacker might be able to hijack an autonomous ship by breaking into a ship's control system, rather than controlling a traditional ship by controlling its crew. However, the nature of hackers' control of autonomous ships through the Internet is currently highly controversial, and the results of

---

<sup>1</sup> See note 2 above.

a fact-finding may include piracy, theft, capture, seizure or detention.<sup>1</sup> This will make the insured of the autonomous ship get confused, and also discourage the insurance company, which is optimistic about the profitability of the autonomous ship industry, from signing the insurance contract to avoid related risks. But just as Inga Beale, Lloyd's chief executive points out, the problem does not lie with insurance companies, but rather with regulators and international law assenting that the technology is safe. If after research, sea trial and market integration, regulators accept that the technology of autonomous ship is safe, insurance companies can have enough courage to take risks in the development of autonomous ship technology.<sup>2</sup>

In recent years, the international community and China have equally devoted attention to ship network security. In December 2015, the International Association of Classification Societies (IACS) established the Cyber System Panel to supervise network security. At the beginning of 2016, The Baltic and International Maritime Conference (BIMCO) issued the world's first guidance on the cyber security of ships. In May 2017, the IMO Maritime Safety Committee at its 96th session adopted and subsequently issued a circular letter entitled *Guidelines on Maritime Cyber Risk Management*. In July 2017, CSS issued *Guidelines for Requirement and Security Assessment of Ship Cyber System*<sup>3</sup>. On May 1, 2018, *Guidelines for Survey of Intelligent Integral Platform* formulated by CSS came into effect, which specified detailed requirements on network and data. It can be noted that the network security of autonomous ships has a certain institutional guarantee, and the technical risks of autonomous ships borne by insurance companies would be correspondingly reduced.

Thereupon, this paper suggests that the nature of the intrusion into the autonomous ship through the network should be studied and confirmed, and the corresponding insurance program should be set up to share the network risk in the development process of the autonomous ship. An insurance company, of course, can also require that the autonomous ship network security system meets the standards as a precondition of insurance, such as requiring the design of autonomous ship's network security management system and the cybersecurity management of the company to fit the *Rules for Intelligent Ships, Guidelines for Survey of Intelligent Integral Platform, Guidelines for Requirement and Security Assessment of Ship Cyber System* and so on.

## 5. Conclusion

With the rapid development of autonomous ship technology, international organizations as well as countries are actively exploring and formulating relevant rules and regulations to cope with the challenges. The Chinese government and relevant industries also commit great attention to the problem of autonomous vessels. According to *Guidance for the Construction of Standard System of Intelligent Ship (draft for comments)*, the Chinese government has set the goal of basically forming a standard system for intelligent vessels by 2025.

Under the current Chinese law, autonomous vessels are generally applicable to the relevant legal system of ships. However, due to the lack of corresponding considerations

---

<sup>1</sup> WANG Guohua, SUN Yuqing, Pirates in the 21st century: legal impediments to the navigation safety of unmanned ships(2018)04 *Chinese Journal of Maritime Law* p 108.

<sup>2</sup> Stephanie Guerra, Ready about, Here Comes AI: Potential Maritime Law Challenges for Autonomous Shipping(2017)30 *U.S.F. MARITIME LAW JOURNAL* p 84.

<sup>3</sup> On March 1, 2020, *Guidelines for Requirement and Security Assessment of Ship Cyber System (2020)* takes effect, revising the 2017 Edition.

at the beginning of the legislation, some specific legal rules are difficult to apply to autonomous ships, and along with other problems such as the lack of relevant standards and inspection norms. For maritime management legal rules, on the one hand, flawed provisions should be amended to capture autonomous ships into the legal system of ships, such as the relevant provisions on "minimum safe manning". On the other hand, existing legislation on autonomous ships should be improved, such as formulating specific inspection technical rules of statutory survey on autonomous ship. For the most part regarding maritime law, it is necessary to keep up with the legislation trend of autonomous ship in the international community, study the liability of autonomous ship carrier, the principle of attribution of ship collision, salvage at sea, relevant network risk insurance and piracy, and improve relevant provisions.

In general, as an emerging technology, the Chinese government has formulated favourable policies, guidelines and norms to encourage the development of autonomous ship technology. It is becoming increasingly essential that, both the international community and governments should shore up the development of autonomous ship technology with respect to legal system, providing legal safeguards, and enabling some space for fault tolerance and innovation for the development of autonomous ship.

Editor (English): Evans Tetteh



# 低空污排放港埠管里：政策观点

曾柏兴\*

**摘要：**本研究采用专家深度访谈方式探讨低空污排放港埠实务与绿色港埠策略意涵，16位受访者(采扎根理论半结构式面对面访谈)来自台湾三大主要港口(高雄港、基隆港、台中港)，空污探讨议题(如氮氧化物、二氧化硫、二氧化碳、一氧化碳、悬浮微粒、挥发性有机物)包括船舶与卡车，研究发现指出利害关系人(如港埠管理当局、码头业者、码头周遭居民)应从更广泛的角度重视港埠规划与发展，空气污染减量策略(如岸电系统、低硫燃料、碳税、进港减速、港区空气质量标准、执行国际公约应具弹性设计与管里，并藉由绿色港埠策略以期达成资源合理利用与环境平衡。

**关键词：** 空气污染 船舶 港埠 政策

## 一、前言

每个港埠对于经济与环境皆会带来正面与负面的影响<sup>1,2</sup>，随着全球化国际贸易的发展，导致许多货物在世界各个港埠进行转运，这个现象造成许多船舶停留在港埠与卡车往返港埠期间增加许多空气污染，间接地产生许多外部社会成本<sup>3</sup>。此外，港埠的建造、营运、扩建都会产生空气污染、温室气体改变、酸雨、优养化、健康、交通拥挤、噪音等问题。这些负面的外部影响是显著的，然而过去在港口发展的意涵上较少被重视。国际海事组织曾从技术面与市场机制方式探讨如何降低航运的温室气体效应。譬如，降低船速<sup>4</sup>或利用轨道式门式机来取代轮胎式起重机。再者，欧洲的永续生态港是让海运迈入友善与环保产业的重要步骤且可与其他伙伴增加更多贸易与合作的机会<sup>5</sup>。在今日，强化港埠发展的环境影响是应被重视的，

---

\* 曾柏興，台湾海洋大学航运管理系助理教授，此文章感谢科技部研究经费补助(編號: MOST 105-2410-H-035-030)，Email: phtseng@mail.ntou.edu.tw.

### ©THE AUTHOR AND MARINE LAW AND POLICY

<sup>1</sup> Diane Bailey and Gina Solomon, Pollution Prevention at Ports: Clearing the Air, *Environmental Impact Assessment Review*, Vol. 24, 2004, pp. 749~774.

<sup>2</sup> Po-Hsing Tseng and Pilcher Nick, Evaluating the Key Factors of Green Port Policies in Taiwan through Quantitative and Qualitative Approaches, *Transport Policy*, Vol. 82, 2019, pp.127~137.

<sup>3</sup> SusanaL ópez-Aparicio, Dag Tønnesen and The Nguyen Thanh, Heidi Neilson, Shipping Emission in a Nordic port: Assessment of mitigation strategies, *Transportation Research Part D: Transport and Environment*, Vol. 53, 2017, pp. 205~216.

<sup>4</sup> Haakon Lindstad, BjørnAsbjørnslett and Anders Strømman, Reductions in Greenhouse Gas Emissions and Cost by Shipping at Lower Speeds, *Energy Policy*, Vol. 39, 2011, pp. 3456~3464.

<sup>5</sup> Gul Denktas-Sakar and CimenKaratas-Cetin, Port Sustainability and Stakeholder Management in Supply Chains: A Framework on Resource Dependence Theory, *The Asian Journal of Shipping and Logistics*, Vol. 28, No. 3, 2012, pp. 301~320.

因这些议题对于国家港埠规划与经济发展是有相关的<sup>1</sup>。譬如,它将影响国家的整体碳排放量而影响空气污染的程度<sup>2</sup>,且对于港口的利害关系人也会带来严重影响,包括港区周遭居民。从健康与经济的观点而言,低空污排放可能会限制一些港区活动才可使这些负面影响能够显著降低。

目前而言,大部分研究采取量化角度探讨港埠低空污排放议题,较少从质化的观点来进行,然而质性的研究可探究更深层人性的观点(如涵盖利害关系人的政策建议)来强化量化研究的不足<sup>3</sup>,更重要的是若这些政策建议是有效且可持续推动,这将有助于未来实施成功的重要关键<sup>4</sup>,本研究将提供港埠利害关系人(如港口当局、航运业者等)的政策意涵,文章的架构如下,第二节为回顾与综整现行关于绿色与低空污排放港口的文献,第三节为提供本研究所使用的质化研究方法,第四节为针对研究结果进行讨论,最后,第五节为总结本研究发现。

## 二、文献回顾

许多量化研究曾指出船舶引擎、锅炉燃烧过程排放出的废气是空气污染与温室气体的重要来源<sup>5,6</sup>,特别是其靠泊船席装卸货期间船舶引擎产生的空气污染。这些来自船舶的空气污染物包括二氧化碳、二氧化硫、氮氧化物、一氧化碳、悬浮微粒、碳氢化合物、挥发性有机物等<sup>7,8</sup>,这些负面效应可能导致环境酸化与形成二次无机性气胶,并导致港口城市空气污染,随着船舶活动的成长,港口城市应尽早作好空气污染减量策略与兼顾港口与沿岸发展的永续平衡根据过去研究<sup>9</sup>,船舶在船席排放的废气是形成港区空气污染重要元素,其排放量是高于港区其他活动(如船舶操纵、巡航)空气污染量3~5倍,因此,目前而言,船舶在船席停靠期间所排放空污已

---

1 Po-Hsing Tseng, *Exploring Ship Emissions Mitigation Strategies for the Port of Shanghai, China* *Oceans Law Review*, Vol. 22, pp. 333-334.

2 Mei Davies, *Emissions Trading for Ships- A European Perspective*, *Naval Engineers Journal*, Vol. 3, 2006, pp. 131-138.

3 Norman Denzin and Yvonna Lincoln, *The Discipline and Practice of Qualitative Research*. In Denzin, N.K., Lincoln, Y.S. (eds.), *The SAGE Handbook of Qualitative Research*. Thousand Oaks: Sage Publications, 2005.

4 Niccolo Machiavelli, *The Prince*. Florence: Antonio Blado d'Asolo, 1532.

5 Giovanni Lonati, Stefano Cernuschi and Shelina Sidi, *Air-quality Impact Assessment of at-berth Ship Emissions: Case-study for the Project of A New Freight Port*, *Science of the Total Environment*, Vol. 409, 2010, pp. 192-200.

6 Gara Villalba and Eskinder Demisse Gemechu, *Estimating GHG Emissions of Marine ports-the Case of Barcelona*. *Energy Policy*, Vol. 39, No. 3, 2011, pp. 1363-1368.

7 Warre Fitzgerald, Oliver Howitt and Inga Smith, *Greenhouse Gas Emissions from the International Maritime Transport of New Zealand's Imports and Exports*, *Energy Policy*, Vol. 39, No. 3, 2011, pp. 1521-1531.

8 Emeston Tzannatos, *Ship Emissions and their Externalities for the Port of Piraeus-Greece*, *Atmospheric Environment*, Vol. 44, 2010, pp. 400-407.

9 Cengiz Deniz, Alper Kilic and Gokhan Civkaroglu, *Estimation of Shipping Emissions in Candarli Gulf, Turkey*, *Environmental Monitoring and Assessment*, Vol. 171, 2010, pp.219-228.



成为港口当局关切的重要议题<sup>1,2</sup>,因这些负面效应对港区从业人员与附近居民带来严重的健康问题,如气喘、心血管疾病、呼吸道疾病、肺癌、早产儿等。

当前气候变迁已成为全球环境的重要议题,若随着港口运量的成长,港口管理当局将面临如何有效处理货物的庞大压力,因此过去许多海运专家(含学术界与海运实务界)曾提出有效的策略来降低海运的空气污染<sup>3</sup>,譬如使用先进的货物处理系统、先进的码头设计、污染物减量科技等,以期减轻对土地与环境的压力<sup>4</sup>。为了改善港口环境,加州洛杉矶港曾实施一些空气污染减量策略,包括导入新型科技、货物处理流程、政策制定与规划机制等以期能在财务、设备更新、作业基础结构系统上能获得改善,故空气污染议题在港口规划阶段就应该加以重视。

在中国,有学者<sup>5</sup>使用归纳式研究步骤探讨低碳城市如何实行在港口,并提出一些改善政策,如建立港埠低碳排放的标准、采用干净能源、增加政策与财务的支持等<sup>6</sup>。

在瑞典,有学者曾预测 Gothenburg 港区在 2030 年的船舶空气污染排放,利用三个情境(替代能源、船舶设计、作业模式改良)进行分析,在 2030 年,假设目前的营运状况持续进行情况下,船舶在港区的温室气体排放将增加 40%,减量效果最好的情境为作业模式改良,其可使空气污染排放降低目前营运状况的 10%<sup>7</sup>,近几年来,科技的政策(如低硫燃料、选择性催化还原法)、作业政策(如船舶减速、岸电使用)与市场机制政策(如差异化的环境税、排污交易)已在许多先进港埠实施,因这些政策可有效降低港埠空气污染及其海运运输的外部成本<sup>8,9</sup>。此外,利用天然气与甲醇也是提供低碳航运的潜在有效方法。在亚洲(如新加坡港与上海港)与欧洲(如安特卫普港、鹿特丹港)已开始采用不同管理工具(如定价策略、侦测与衡量、市场进入控制、环

<sup>1</sup> Joseph Berechman, Y. and Po-Hsing Tseng, Estimating the Environmental Costs of Port Related Emissions: the Case of Kaohsiung, *Transportation Research Part D: Transport and Environment*, Vol. 17, 2012, pp. 35~38.

<sup>2</sup> Kevin Cullinane, Po-Hsing Tseng and Gordon Wilmsmeier, Estimation of Container Ship Emissions at Berth in Taiwan, *International Journal of Sustainable Transportation*, Vol. 15, No. 5, pp. 466~474.

<sup>3</sup> Paul Gilbert and Alice Bows, Exploring the Scope for Complementary Sub-global Policy to Mitigate CO<sub>2</sub> from Shipping, *Energy Policy*, Vol. 50, 2012, pp.613-622.

<sup>4</sup> Wei Yim Yap and Jasmine Siu Lee Lam, 80 Million-twenty-foot-equivalent-unit Container Port? Sustainability Issues in Port and Coastal Development, *Ocean & Coastal Management*, Vol. 71, 2013, pp. 13~25.

<sup>5</sup> Peter Hall, Thmos O'Brien and Clarence Woudsma. Environmental Innovation and the Role of Stakeholder Collaboration in West Coast Port Gateways, *Research in Transportation Economics*, Vol. 42, No. 1, 2013, pp. 87~96.

<sup>6</sup> Jian Li, Xiao Liu and Bao Jiang, An Exploratory Study on Low-carbon Ports Development Strategy in China, *The Asian Journal of Shipping and Logistics*, Vol. 27, No. 1, 2011, pp. 91~111.

<sup>7</sup> Hulda Winnes, Linda Styhre and Erik Fridell, Reducing GHG emissions from ships in port areas, *Research in Transportation Business & Management*, Vol. 17, 2015, pp. 73~82.

<sup>8</sup> Haakon Lindstad, Bjørn Asbjørnslett and Anders Strømman, Reductions in Greenhouse Gas Emissions and Cost by Shipping at Lower Speeds, *Energy Policy*, Vol. 39, 2011, pp. 3456~3464.

<sup>9</sup> Chul-Hwan Han, Strategies to Reduce Air Pollution in Shipping Industry, *The Asian Journal of Shipping and Logistics*, Vol. 26, No. 1, 2010, pp. 7~30.

保标准管制等)强化绿色港埠绩效,有研究指出相较于亚洲两个港埠,安特卫普港与鹿特丹港实施较好的绿色港埠政策<sup>1</sup>。最近,上海港已开始实施排放控制区政策以期有效达成船舶空气污染减量(如二氧化硫、悬浮微粒 2.5、二氧化氮),研究进一步指出排放控制区政策在洋山(Yangshan)与吴淞(Wusong)港区可带来显著的空污减量效果<sup>2</sup>。过去有学者针对立陶宛 Klaipeda 港进行个案研究,其指出船舶空气污染排放可透过不同的方式来达成,譬如环保友善的燃料、电动与混合式车辆、港埠作业改善、港区导航改善、运输作业组织的最佳化等<sup>3</sup>。

在一篇希腊港的量化研究指出根据使用者付费原则,押金制度(deposit - refund)机制被认为是有效鼓励船舶采用环保的措施与减少资源浪费<sup>4</sup>。此押金是可退还的,其目的鼓励正确的环保行为来取代对污染者的惩罚。在一些国际海运研究发现燃料税(每公吨150美元)的实施可降低20~30%的二氧化碳排放,同时船舶速度降低可达成20%二氧化碳排放与减少货柜船队成本(每公吨二氧化碳约30~200美金)<sup>5</sup>。在台湾高雄港,在港区20海浬范围内,研究发现实施船舶速度降低与岸电设施可分别降低71%与91%的空气污染排放<sup>6</sup>,并建议港口管理当局与船公司应投资岸电与电力传输相关设备以符合国际港口趋势。在发展绿色港埠方面,许多港埠已开始发展社会责任策略,譬如在瑞典,研究发现实施外部成本内部化的运输系统与分析不同利害关系人的策略可有效达成的绿色港埠<sup>7</sup>。在香港,有研究指出绿色管理实务可包括(1)供应链伙伴的合作(2)环境友善的作业模式(3)内部管理支持,该研究发现采用绿色管理实务对货柜码头公司绩效有正向影响关系<sup>8</sup>。而在荷兰的研究指出达成清洁航运的目标是困难的,原因其涉及不同伙伴合作关系的利益导致难以透过私人自治的机制来达成<sup>9</sup>,其有可能涉及到政治与法律的议题。例如,现行国际海事组织底下的

---

1 Jasmine Siu Lee Lam and Theo Notteboom, *The Greening of Ports: A Comparison of Port Management Tools Used by Leading Ports in Asia and Europe*, *Transport Reviews*, Vol. 34, No. 2, 2016, pp. 169~189.

2 Ku Shi, Jinxian Weng and Guorong Li, *Exploring the Effectiveness of ECA Policies in Reducing Pollutant Emissions from Merchant Ships in Shanghai Port Waters*, *Marine Pollution Bulletin*, Vol. 155, 111164, 2020, <https://doi.org/10.1016/j.marpolbul.2020.111164>

3 Vytautas Paulauskas, Ludmila Filina-Dawidowicz and Donatas Paulauskas, *The Method to Decrease Emissions from Ships in Port Areas*, *Sustainability*, Vol. 12, No. 11, 2020, 4374. DOI: 10.3390/su12114374

4 Dimitrios Georgakellos, *The Use of the Deposit-refund Framework in Port Reception Facilities Charging Systems*, *Marine Pollution Bulletin*, Vol. 54, 2007, pp. 508~520.

5 James Corbett, Haifeng Wang and James Winebrake, *The Effectiveness and Costs of Speed Reductions on Emissions from International Shipping*, *Transportation Research Part D: Transport and Environment*, Vol. 14, 2009, pp. 593~598.

6 Ching-Chih Chang and Chih-Min Wang, *Evaluating the Effects of Green Port Policy: Case Study of Kaohsiung Harbor in Taiwan*, *Transportation Research Part D: Transport and Environment*, Vol. 17, 2012, pp. 185~189.

7 Rickard Bergqvist and Niklas Egels-Zanden, *Green port dues- The case of hinterland transport*, *Research in Transportation Business & Management*, Vol. 5, 2012, pp. 85~91.

8 Lun Venus, *Green Management Practices and Firm Performance: A Case of Container Terminal Operations*, *Resources, Conservation and Recycling*, Vol. 55, 2011, pp. 559~566.

9 Lindey Wuisan and Judith van Leeuwen, C.S.A. Kris Koppen, *Greening international shipping through*

海洋环境污染委员会负责防范船舶于海洋与大气的污染相关工作,海洋环境污染委员会于1988年起藉由MARPOL(73/78)公约开始查核船舶空气污染。在中国,有学者使用通用代数建模系统(general algebraic modeling system)并从经济与环境的观点进行绿色港埠排程,研究发现其可改善作业效率<sup>1</sup>。

这些过去的研究主要采用量化的步骤来调查绿色港埠及其相关的成本议题,然而,仍有较少的实证研究从利害关系人的观点进行质性探讨,特别是亚洲地区国家。过去运输相关领域的质性研究领域常见于海运安全<sup>2</sup>、公交车运输<sup>3</sup>、景观与都市规划<sup>4</sup>。而港埠口议题(特别是低排放港埠)较少从通盘性的观点来研究,本研究目的为填补这个研究缺口并藉由实证访谈的方式来归纳研究发现。

### 三、研究方法

本研究采用质性步骤探讨产业专家与政府官员对于低空污排放港口政策的看法,藉由扎根理论,将复杂的现象转化成特定的议题来进行分析,为求深入了解低空污排放港埠管理策略,台湾三个主要港埠(高雄、基隆、台中)的专家则采扎根理论进行访谈分析。访谈前先了解受访者的背景以确认其为具资格的受访对象(如有10年以上相关工作经验或对研究议题有专业知识),这些潜在专家先由电话进行连络,并采目的抽样方式进行筛选,并根据他们的背景来进行研究问题访谈,在取得这些受访专家愿意参与本研究的意愿后,访谈的地点与日期则进一步与他们确认,访谈日期介于2020年7月1~2020年8月31日,这些受访者则会收到一封正式访谈邀请信并说明他们是自愿参与本研究与了解访谈研究资料如何使用,受访者的姓名则予以匿名保密。所有的受访者的访谈纪录则采数字化编码<sup>5</sup>,并在寄回给原受访者加以确认访谈内容,受访时所采用的语言为中文<sup>6</sup>,再翻译成英文以使访谈的内容能接近

---

private governance: a case study of the clean shipping project, *Marine Policy*, Vol. 36, 12012, pp. 65~173.

<sup>1</sup> Wei Wang, Li Huang, Gu Jian and Liupeng Jiang, Green port project scheduling with comprehensive efficiency consideration, *Maritime Policy & Management*, Vol. 46, No. 8, 2019, pp. 967~981.

<sup>2</sup> Arben Mullai and Ulf Paulsson, A Grounded Theory Model for Analysis of Marine Accidents, *Accident Analysis and Prevention*, Vol. 43, 2011, pp. 1590~1603. U. M. Ikeagwuani and G.A. John, Safety in Maritime Oil Sector: Content Analysis of Machinery Space Fire Hazards, *Safety Science*, Vol. 51, 2013, pp. 347~353.

<sup>3</sup> Rui Carreira, Lia Patricio, Renato Natal Jorge, Chris Mage and Qi Van Eikema Hommes, *Transport Policy*, Vol. 25, 2013, pp. 233~243.

<sup>4</sup> Erin Heacock and Justin Hollander, A Grounded Theory Approach to Development Suitability Analysis, *Landscape and Urban Planning*, 100, 2011, pp. 109~116.

<sup>5</sup> Joseph Alex Maxwell, Understanding and Validity in Qualitative Research, *Harvard Educational Review*, Vol. 62, No. 3, 1992, pp. 270~300. Christina Davidson, Transcription: Imperatives for Qualitative Research, *The International Journal of Qualitative Methods*, Vol. 8, No. 2, pp. 35~62. Blake D. Poland, Transcription Quality. In Jaber F. Gubrium and James A. Holstein, *Handbook of Interview Research*. Thousand Oaks, Calif: Sage Publications, 2001.

<sup>6</sup> Martin Cortazzi, Nick Pilcher and Lixian Jin, Language Choices and 'blind shadows': Investigating Interviews with Chinese Participants. *Qualitative Research*, Vol. 11, No. 5, 2011, pp. 505-535.

真实的样貌<sup>1</sup>，共计16位受访者参与研究，资料收集包括访谈时的观察与访谈内容，受访者的单位包括台湾港务股份有限公司(含高雄、基隆、台中)、航港局(含北部、中部、南部航务中心)。访谈内容采半结构与开放式内容进行<sup>2</sup>，上述的访谈方式可强化资料收集的内容与理论发展，16位受访者为管理阶层主管，职称包括局长/董事长(2位)、港埠营运经理(6位)、码头业者(6位)与4位利害关系人(2位)，以期能了解政策意涵，并根据量化文献中提到的关键名词(如空气污染、管制、国际公约、船舶污染国际公约、碳税、港埠、码头、航商、货主)来进行深入访谈，访谈资料则透过初始与焦点编码，编码则根据相关主题与概念并进一步形成理论性的命题，访谈的编码与范例详如附录。

#### 四、发现与讨论

一般而言，许多控制与减少空气污染的政策行动可分为管制要求与市场导向(或诱因导向)两类<sup>3</sup>，本研究受访者的看法可归纳为下列四点减量策略。

##### 4.1 以经济诱因来达成空气污染减量

从经济观点，受访者认为污染外部性为社会成本，这些是由船舶与卡车使用者来产生<sup>4</sup>。为内部化这些成本，可采行 Pigouvian 税<sup>5</sup>来管制这些污染活动以减少无谓的船舶与卡车活动，譬如采用边际社会成本超过社会边际利益时，就该课征该污染税。因船舶的空气污染排放量是根据船舶靠泊船席的时间而定，因此时间影响空气污染成本的关键因素，停靠船席时间越长，应课征越高的污染成本。

从福利经济学的观点来看，应思考这些所课征的污染税该用在哪里，一般而言，这些污染税的配置应从两个方向来思考，首先为用于空气质量改善目的，譬如港埠管理单局补助使用较具能源效率船舶引擎的船东或遵守排放控制区规定的船东(如给予船席费折扣)作为诱因，第二为补助港埠周遭受到空气污染健康问题的居民。不管在何种情况下，港埠当局应针对排放空气污染的船舶课征税费，并提供诱因给

---

<sup>1</sup> O. Werner and D. Campbell, *Translating, Working through Interpreters, and the Problem of Decentering*. In R. Naroll & R. Cohen (eds.), *A Handbook of Method in Cultural Anthropology*. New York: Natural History Press, 1970. Hans J. Vermeer, *Skopos and Commission in Translational Action*. In L. Venuti (ed) *The Translation Studies Reader* (2nd edition), London: Routledge, 2004.

<sup>2</sup> William Foddy, *Constructing Questions for Interviews and Questionnaires: Theory and Practice in Social Research*. Cambridge University Press, 1993.

<sup>3</sup> Chengfeng Wang, C., James J. Corbett and James J. Winebrake, Cost-effectiveness of Reducing Sulfur Emissions from Ships, *Environmental Science & Technology*, Vol. 41, No. 24, 2007, pp. 8233-8239. Vytautas Paulauskas, The Method to Decrease Emissions from Ships in Port Areas, *Sustainability*, Vol. 12, No. 11, 2020, pp.11~15.

<sup>4</sup> Alvar Mjelde, Øyvind Endresen, Einar Bjørshol, Caroline Wang Gierløff, Even Husby, Johanne Solheim, Narve Mjøs and Magnus S. Eide, *Differentiating on Port Fees to Accelerate the Green Maritime Transition*, *Marine Pollution Bulletin*, Vol. 149, 110561. DOI: 10.1016/j.marpolbul.2019.110561

<sup>5</sup> A. C. Pigou, *Economics of Welfare*. London, UK: Macmillan and Co., 1920.

船东让他们愿意采取措施来降低空气污染<sup>1</sup>。

## 4.2 使用岸电系统来取代船舶辅助引擎

受访者建议可广泛大量使用岸电系统来取代传统船舶靠泊船席时燃烧的辅助引擎，藉此可降低空气污染，目前靠泊船席的船舶必须燃烧辅助柴油引擎以提供基本的电力给电灯、空调系统、泵、起重机及必要的设备<sup>2</sup>。因此可藉由岸上提供电力供应标准化插座设备来取代船舶辅助引擎<sup>3</sup>。过去在挪威、法国、美国曾经使用岸电仍能成功减少二氧化碳分别达到99.5%、85.0%、9.4%减量效果<sup>4</sup>。为鼓励使用岸电系统，港埠单位可采用港埠费折扣或差异化的吨税制度来提供诱因。然而，目前台湾尚无管制航商需使用岸电系统的法令，许多较老旧的船舶因装置成本考量而不愿使用岸电系统，这些老旧船舶就无法派遣到先进港口(如美国地区)。此外，使用岸电系统的规定有时会考虑船籍规定，相较其他先进港口(如香港、新加坡、洛杉矶、长堤)，台湾使用岸电系统的步调是较慢的，在未来新船建造将配置岸电设备且使用率将会提升。

## 4.3 改善港埠作业效率

受访者指出可藉由改善港埠作业效率来降低空气污染，因船舶在船席的时间是影响空气污染重要因素，若能导入先进设施(如货柜桥式起重机、轨道式门式机、货柜堆积机)可改善船舶在船席的货物装卸效率，将可进一步降低空气污染的严重性与外部性<sup>5</sup>，目前，为达成有效率的装卸服务，目前在台湾的港埠仅有少数航商使用专用码头，其他未具有专用码头的航商并无靠泊优先权而必须在公用码头采等候的方式安排船席(由于成本考量)，从绿色港埠管理观点，港埠当局应提供更多专用码头租赁方案给采用环保措施的航商(譬如在港区内采用低硫燃料来取代传统燃油)<sup>6</sup>。此外，可透过货柜场储存策略来改善土地利用与作业效率，以降低货柜吊挂与作业循环时间，进而降低货柜场的拥挤程度。

## 4 采用科技创新来降低空气污染

受访者认为科技创新可提供潜在的机会来降低船舶与卡车空气污染，譬如天然

<sup>1</sup> Celeste Ahi, Elaine Frey and Seiji Steimetz, The Effects of Financial Incentives on Vessel Speed Reduction: Evidence from the Port of Long Beach Green Flag Incentive Program, *Maritime Economics & Logistics*, Vol. 19, No. 4, 2017, pp. 601~618.

<sup>2</sup> Jihong Cheng, Tianxiao Zheng, Akhil Garg, Lang Xu, Sifan Li and Yijie Fei, Alternative Maritime Power application as a green port strategy: Barriers in China, *Journal of Cleaner Production*, Vol. 213, 2019, pp. 825~837.

<sup>3</sup> Markus Salomon, Recent European Initiatives in Marine Protection Policy: Toward Lasting Protection for Europe's Seas? *Environment Science & Policy*, Vol. 12, 2009, pp. 359~366.

<sup>4</sup> Willaim Hall, Assessment of CO<sub>2</sub> and Priority Pollutant Reduction by Installation of Shoreside Power, *Resources, Conservation and Recycling*, Vol. 54, 2010, pp. 462~467.

<sup>5</sup> Yi-Chih Yang, Operating Strategies of CO<sub>2</sub> Reduction for A Container Terminal based on Carbon Footprint Perspective, *Journal of Cleaner Production*, Vol. 141, 2017, pp. 472~480.

<sup>6</sup> Ching-Chin Chang and Chia-Wei Jhang, Reducing Speed and Fuel Transfer of the Green Flag Incentive Program in Kaohsiung Port Taiwan, *Transportation Research Part D*, 46, 2016, pp. 1~10.

气可作为小型船舶(如拖船、商用渔船)靠泊船席时的替代能源<sup>1</sup>,此外,清洁能源(如燃料电池、低硫燃料、生物柴油、液化天然气)相较于现行海运柴油提供更多优点,譬如较低的空气污染排放(藉由柴油氧化触媒、柴油碳微粒滤清器)、改良热效率、电力化等(如自动车辆、混合(hybrid)码头设施)。然而,导入新科技(如物联网、大数据<sup>2</sup>)对航运业者而言是需要庞大成本,其可能在港埠当局与航运业者间形成议价力量,<sup>3</sup>此外,无人船也可能是未来的趋势,因其可显著降低空气污染。然而,无人船除了较高的建造成本外,国际海事组织(含内部利害关系人(如成员国、顾问、委员会)与外部利害关系人(如非政府组织))对于这项新科技尚未有完整的航运规范,因此,有必要将这些新科技整合于管制规范里。再者,航商可进一步与其他区域组织进行合作以提升创新能力。例如由于科技快速改变,航运当局可参与协助国际海事组织制订船舶能源效率的标准规范,此外,自动导引车与自动码头起重机在自动化码头系统的运用将会是未来发展趋势(特别是轴心港<sup>4</sup>),对于装卸作业应有清楚的作业规范以供利害关系人(如航商、码头业者、港埠代理业等)及早准备,且碳交易机制也可能是未来的解决方案。<sup>5</sup>

## 五、结论

为发展低空污排放港口,根据16位专家的意见,本研究采用质化步骤收集与分析不同港埠利害关系人的观点。此质化方式可采深度方式汇整四个减量策略,包括经济诱因、岸电系统、港埠作业效率(如货柜储存策略)与创新科技(如清洁燃料、自动作业系统)等。本研究建议港埠规划与发展应考虑三个重要利害关系人的想法,包括港埠/码头业者、航商、货主等。任何的空气污染减量策略应从广泛的角度来设计具弹性的管理方式,譬如,港埠税(碳税)应由港埠当局来课征且由航商来支付。再者,应提高对于不同利害关系人的接受度与提供激励诱因(如采用节能方式来给予港埠税减免)以达到资源使用最佳化(或资源共享)与环境平衡。

Increasing stakeholder acceptance and providing initiatives (e.g. port tax reduction via adopting energy-saving methods) to achieve resource use rationalization (or resource sharing)

<sup>1</sup> Lei Yang, Yiji Cai, Yunlei Wei and Shou Huang, Choice of Technology for Emission Control in Port Areas: A Supply Chain Perspective, *Journal of Cleaner Production*, Vol. 243, 2019, 118105. <https://doi.org/10.1016/j.jclepro.2019.118105>

<sup>2</sup> Xing Sun, Zhe Tian, Reza Malekian and Zhixiong Li, Estimation of Vessel Emission Inventory in Qingdao Port based on Big Data Analysis, *Symmetry*, Vol. 10, No. 10, 2018, pp. 452-1~452-11. 10.3390/sym10100452

<sup>3</sup> Dong Bo, Dong Kangcheng, Chen Guang, Cao Huiyun and Ya Hongying, Carbon Emission Management System of Port Logistics based on Internet of Things Technology, *Agro Food Industry Hi-Tech*, Vol. 28, No. 1, 2017, pp. 1094~1098.

<sup>4</sup> Kap Hwan Kim and Jong Wook Bae, A Look-Ahead Dispatching Method for Automated Guided Vehicles in Automated Port Container Terminals, *Transportation Science*, Vol. 38, No. 2, 2004, pp.224~234.

<sup>5</sup> Yuxia Peng and Yanping Meng, Research on Carbon Emission Reduction Decisions of Ports with Low Carbon Preference under Carbon Trading Mechanism, *International Journal of Social Science and Education Research*, Vol. 3, No. 9, 2020, pp. 330~321.

and environment balance.

## 致谢

作者感谢台湾科技部经费补助(编号: MOST 105-2410-H-035-030)。

## 附录

非常感谢您参与此次研究。我将详实记录此访谈内容, 而非仅作摘录重点, 此访谈过程会是轻松自由的, 因此我不清楚会花多少时间, 不过估计是一个小时, 在访谈过程中请在任何时刻自由地提出任何问题, 我也有可能会是如此, 如此进行方式可以协助我从您的观点来了解访谈内容, 简要的编码内容如表 1 所示。

表 1 编码与范例

编码分类	描述	范例
公约	当执行港口国管制时采用国际公约(如防止船舶污染国际公约)来检查	“航商应自主性遵守国际公约”。产业专家 01.
碳税	污染产生者付费	“港埠污染产生者负担碳税是合理的, 其可有效降低港区附近的空气污染”。政府专家 01. “碳交易机制可能会是为来的趋势”。政府专家 02.
管制	采用空污减量策略(如低硫油、岸电系统、进港减速)来达到绿色港埠目标.	“我们将遵守港埠当局所制定的污染管制规定, 即使会增加我们的营运成本”。产业专家 02.

Codified Category	Descriptions	Exemplar Quote
Conventions	Adopt international conventions (e.g. MARPOL) when implementing Port State Control check	“Shipping lines should autonomously follow international conventions”. Industry Expert 01.
Carbon tax	Polluters pay the pollution fees	“It is reasonable that port polluter pay the carbon tax in order to reduce emission around the port area”. Government Expert 01. “Carbon Trading Mechanism might be a future trend”. Government Expert 02.
Regulations	Adopt emission mitigation strategies (e.g. low sulfur fuel, shore power, reduced speed) to achieve green port target.	“Our company will follow pollution regulation rules of port authorities even it might add our operation costs.” Industry Expert 02.

# Low Emission Port Development: The Policy Perspective

Po-Hsing TSENG\*

**Abstract:** In this paper, an in-depth interview study of the practice within low emission port was undertaken to ascertain strategy implication for green port issues. Sixteen semi-constructed face-to-face interviews (including industry experts and governmental officers) were conducted in three main ports (Kaohsiung, Keelung, and Taichung) in Taiwan based on grounded theory methodology. The main focus of the study was streamlined to emissions (e.g. NO<sub>x</sub>, SO<sub>2</sub>, CO<sub>2</sub>, CO, PM, VOC) from ships and trucks. The findings show that stakeholders as for example port authorities, terminal operators and residents surrounding the ports should pay more attention to the port planning and development from a broad perspective. Moreover, the mitigation strategies of air pollution (e.g. shore power system, low sulphur fuel, carbon tax, reduced speed when arriving at the port, air quality standards within the port area, the implementation of international conventions like MARPOL, etc.) should be flexibly designed and managed to achieve resource use rationalization and environmental balance by adopting green port policies.

**Keywords:** Emission Ship Port Policy

## 1. INTRODUCTION

Every port has its positive and negative impact on the economy and the environment<sup>1,2</sup>. The expansion of international trade arising from globalization has resulted in a substantial increase in goods' transshipment between ports around the world. This phenomenon has led to increased emissions from ships in ports, and trucks traveling to and from ports, which, in turn, has produced significant external social costs.<sup>3</sup> The construction, operation and expansion of a port may produce air pollutants, climate change, acidification, eutrophication, health, traffic congestion, and noise. These negative external impacts are significant but have seldom been highlighted as being environmental implications of port development in the past. The International Maritime Organization (IMO) has debated both technical and market-based measures for reducing greenhouse

---

\* TSENG Po-hsing, Assistant Professor of Department of Shipping and Transportation Management, Taiwan Ocean University. The author appreciates the fund provided by the Ministry of Science and Technology under grant number MOST 105-2410-H-035-030. Email:phtseng@mail.ntou.edu.tw.

©THE AUTHOR AND MARINE LAW AND POLIC

<sup>1</sup> Diane Bailey and Gina Solomon, Pollution Prevention at Ports: Clearing the Air, *Environmental Impact Assessment Review*, Vol. 24, 2004, pp. 749~774.

<sup>2</sup> Po-Hsing Tseng and Pilcher Nick, Evaluating the Key Factors of Green Port Policies in Taiwan through Quantitative and Qualitative Approaches, *Transport Policy*, Vol. 82, 2019, pp.127~137.

<sup>3</sup> SusanaL ópez-Aparicio, Dag Tønnesen, The Nguyen Thanh and Heidi Neilson, Shipping Emission in a Nordic port: Assessment of mitigation strategies, *Transportation Research Part D: Transport and Environment*, Vol. 53, 2017, pp. 205~216.



gas emissions from shipping, for example, lower ship speed<sup>1</sup> or rail mounted gantry cranes (instead of rubber tired gantry crane). Moreover, Sustainable Eco-port in Europe is a key step to ensuring environmentally friendly maritime industry and at the same time help increase more trade and cooperation opportunity with other partners<sup>2</sup>. Today, it is important that the knock-on environmental impact of port development is considered and accounted for, since it has an influence on a nation's port planning and economic development.<sup>3</sup> In particular, it can affect the nation's overall carbon emissions, and is becoming more of an issue in tandem with the importance of such overall emissions<sup>4</sup>. These issues also have important impacts on stakeholders of the port, such as the community; from a health perspective, lower emissions have many implications, and from an economic perspective, any limitation of activity to reduce such emissions would also be significant.

To date, most studies into this area have been quantitative in nature rather than qualitative. Qualitative studies would complement the existing quantitative ones to present more in-depth 'human' perspectives<sup>5</sup> regarding stakeholders' perceptions of the policies and recommendations the quantitative studies have offered. This is important as it reveals how such policies are perceived, and therefore, ensures the potential success of their take-up and implementation, particularly when they may involve significant changes to existing practices, which may be resisted<sup>6</sup>. The results of this study provide policy implications for port stakeholders such as port authorities and shipping operators. The paper is organized as follows: Section 2 reviews and summarizes some existing studies related to green and low emission port. Section 3 presents the qualitative methodology that was used. The study results and discussion are shown in sections 4. Finally, Section 5 summarizes the research finding.

## 2. LITERATURE REVIEW

Many quantitative studies recognize the role of emission from ships during the combustion process in marine diesel engines, boilers, and incinerators as significant sources of air pollution and greenhouse gases, especially during the hoteling time of ship engines for loading/offloading operations.<sup>7</sup> The main pollutants resulting from ship

---

<sup>1</sup> Haakon Lindstad, BjørnAsbjørnslett and Anders Strømman, *Reductions in Greenhouse Gas Emissions and Cost by Shipping at Lower Speeds*, *Energy Policy*, Vol. 39, 2011, pp. 3456~3464.

<sup>2</sup> Gul Denktas-Sakar and CimenKaratas-Cetin, *Port Sustainability and Stakeholder Management in Supply Chains: A Framework on Resource Dependence Theory*, *The Asian Journal of Shipping and Logistics*, Vol. 28, No. 3, 2012, pp. 301~320.

<sup>3</sup> Po-Hsing Tseng, *Exploring Ship Emissions Mitigation Strategies for the Port of Shanghai, China* *Oceans Law Review*, Vol. 22, pp. 333~334.

<sup>4</sup> Mei Davies, *Emissions Trading for Ships- A European Perspective*, *Naval Engineers Journal*, Vol. 3, 2006, pp. 131~138.

<sup>5</sup> Norman Denzin and Yvonna Lincoln, *The Discipline and Practice of Qualitative Research*. In Denzin, N.K., Lincoln, Y.S. (eds.), *The SAGE Handbook of Qualitative Research*. Thousand Oaks: Sage Publications, 2005.

<sup>6</sup> Niccolo Machiavelli, *The Prince*. Florence: Antonio Blado d'Asolo, 1532.

<sup>7</sup> Giovanni Lonati, Stefano Cernuschi and Shelina Sidi, *Air-quality Impact Assessment of at-berth Ship*

exhaust emissions are, by mass, carbon dioxide (CO<sub>2</sub>), Sulfur dioxide (SO<sub>2</sub>), nitrogen oxides (NO<sub>x</sub>), carbon monoxide (CO), particulate matter (PM), hydrocarbons (HC) and volatile organic compounds (VOC).<sup>1,2</sup> The negative effects of such pollutants might contribute to acidification of the environment and the formation of secondary inorganic aerosols which consequently cause air pollution in the port-city area. With the surge in shipping activities, port city authorities plan mitigation strategies against air pollution to achieve a sustainable balance in port and coastal development. Based on past studies<sup>3</sup>, ship emissions at berth determine the concentration of exhaust emissions in ports which are between three to five times higher than from other activities in ports (e.g., maneuvering and cruising). Understandably, these emissions from ships at berth have become a great concern for port authorities.<sup>4</sup> These negative effects have brought serious health problems such as asthma, cardiovascular disease, respiratory disease, lung cancer and premature mortality to port operators and residents of local communities around the ports.

Maritime experts have attempted to provide effective strategies to reduce emissions from shipping in light of the fact that climate change is now a global environmental concern<sup>5</sup>. The port authorities are likely to face immense pressure in cargo traffic-handling given that cargo throughput is projected to increase in the future. For such reasons, various strategies have been presented within both academic and industrial fields. For example, it is argued that on-going advances in cargo-handling systems, terminal design and pollution abatement technologies could help to alleviate the pressures on land use and the environment.<sup>6</sup> Besides air pollution issues should be considered at the planning stage of port development.

In order to improve port environment, in California and Los Angeles, some pollution mitigation policies were implemented through new technologies and processes for handling and moving cargo, mechanisms for planning and policy making, as well as for financing, implementing, upgrading, managing and operating infrastructure systems.

---

Emissions: Case-study for the Project of A New Freight Port, *Science of the Total Environment*, Vol. 409, 2010, pp. 192~200. Gara Villalba and Eskinder Demisse Gemechu, Estimating GHG Emissions of Marine ports-the Case of Barcelona. *Energy Policy*, Vol. 39, No. 3, 2011, pp. 1363~1368.

<sup>1</sup> Warre Fitzgerald, Oliver Howitt and Inga Smith, Greenhouse Gas Emissions from the International Maritime Transport of New Zealand's Imports and Exports, *Energy Policy*, Vol. 39, No. 3, 2011, pp. 1521~1531.

<sup>2</sup> Emeston Tzannatos, Ship Emissions and their Externalities for the Port of Piraeus-Greece, *Atmospheric Environment*, Vol. 44, 2010, pp. 400~407.

<sup>3</sup> Cengiz Deniz, Alper Kilic and Gokhan Civkaroglu, Estimation of Shipping Emissions in Candarli Gulf, Turkey, *Environmental Monitoring and Assessment*, Vol. 171, 2010, pp.219~228.

<sup>4</sup> Joseph Berechman, Y. and Po-Hsing Tseng, Estimating the Environmental Costs of Port Related Emissions: the Case of Kaohsiung, *Transportation Research Part D: Transport and Environment*, Vol. 17, 2012, pp. 35~38. Kevin Cullinane, Po-Hsing Tseng and Gordon Wilmsmeier, Estimation of Container Ship Emissions at Berth

<sup>5</sup> Paul Gilbert and Alice Bows, Exploring the Scope for Complementary Sub-global Policy to Mitigate CO<sub>2</sub> from Shipping, *Energy Policy*, Vol. 50, 2012, pp.613-622.

<sup>6</sup> Wei Yim Yap and Jasmine Siu Lee Lam, 80 Million-twenty-foot-equivalent-unit Container Port? Sustainability Issues in Port and Coastal Development, *Ocean & Coastal Management*, Vol. 71, 2013, pp. 13~25.

Using an inductive research approach.<sup>1</sup> In China, low-carbon ports were widely implemented in many ports and related policies included setting standards of low-carbon port emissions, exploiting clean energy and increasing the support of policy and finance.<sup>2</sup> In Sweden, projections of ship emissions in the Gothenburg port area for 2030 are made, and three scenarios (alternative fuel, ship design, and operation) have been analyzed. GHG emissions from ships in the port are projected to increase by 40% to 2030 in a business as usual (BAU) scenario. The highest reductions were seen in the ‘Operation’ scenario where GHG emissions were 10% lower than the BAU level.<sup>3</sup> In recent years, technological policies (lower sulfur fuel and selective catalytic reduction), operational policies (vessel speed reduction and shore-side power) and market-based policies (environmentally differentiated fee, and cap and trade system) were implemented in many advanced ports since it can effectively reduce port emissions and its external costs of maritime transport.<sup>4,5</sup> Also, liquefied natural gas and methanol could provide potential bridge to reach low emission ship transports. Asia (Singapore and Shanghai) and Europe (Antwerp and Rotterdam) were used to compare the green port performance through various management tools (e.g. pricing, monitoring and measuring, market access control and environmental standard regulation). Findings showed that Antwerp and Rotterdam have a higher level of influence on devising green port policy in comparison to the two Asian ports.<sup>6</sup> Recently, Emission Control Area policy was used to evaluate the effectiveness of reducing emissions (e.g. SO<sub>2</sub>, PM<sub>2.5</sub>, NO<sub>x</sub>) from merchant ships in Shanghai port. Findings indicted that future ECA policies could bring a much greater decrease of pollutant emissions in water areas of Yangshan and Wusong.<sup>7</sup> In Lithuania, the Klaipeda Port was used as a case study and found that a decrease in emissions from ships could be achieved by conducting various methods, such as environmentally friendly fuels, electrical and hybrid vehicles, the improvement of port approach, inside navigational channels and optimization of the transport processes organization.<sup>8</sup>

---

<sup>1</sup> Peter Hall, Thmos O’Brien and Clarence Woudsma, Environmental Innovation and the Role of Stakeholder Collaboration in West Coast Port Gateways, *Research in Transportation Economics*, Vol. 42, No. 1, 2013, pp. 87~96.

<sup>2</sup> Jian Li, Xiao Liu and Bao Jiang, An Exploratory Study on Low-carbon Ports Development Strategy in China, *The Asian Journal of Shipping and Logistics*, Vol. 27, No. 1, 2011, pp. 91~111.

<sup>3</sup> Hulda Winnes, Linda Styhre and Erik Fridell, Reducing GHG emissions from ships in port areas, *Research in Transportation Business & Management*, Vol. 17, 2015, pp. 73~82.

<sup>4</sup> Haakon Lindstad, Bjørn Asbjørnslett and Anders Strømman, Reductions in Greenhouse Gas Emissions and Cost by Shipping at Lower Speeds, *Energy Policy*, Vol. 39, 2011, pp. 3456~3464.

<sup>5</sup> Chul-Hwan Han, Strategies to Reduce Air Pollution in Shipping Industry, *The Asian Journal of Shipping and Logistics*, Vol. 26, No. 1, 2010, pp. 7~30.

<sup>6</sup> Jasmine Siu Lee Lam and Theo Notteboom, The Greening of Ports: A Comparison of Port Management Tools Used by Leading Ports in Asia and Europe, *Transport Reviews*, Vol. 34, No. 2, 2016, pp. 169~189.

<sup>7</sup> Ku Shi, Jinxian Weng and Guorong Li, Exploring the Effectiveness of ECA Policies in Reducing Pollutant Emissions from Merchant Ships in Shanghai Port Waters, *Marine Pollution Bulletin*, Vol. 155, 111164, 2020, <https://doi.org/10.1016/j.marpolbul.2020.111164>

<sup>8</sup> Vytautas Paulauskas, Ludmila Filina-Dawidowicz and Donatas Paulauskas, The Method to Decrease Emissions from Ships in Port Areas, *Sustainability*, Vol. 12, No. 11, 2020, 4374.  
DOI: 10.3390/su12114374

In a quantitative study of Greek port, deposit–refund framework is confirmed as a useful method for the operation of ships in a more environmentally responsible manner regarding their waste based on user pay principle.<sup>1</sup> The deposit is refundable, and the system is aimed at rewarding the correct environmental behavior instead of polluters' punishment. With regards to international shipping studies, research found that a fuel tax of approximately \$150/ton fuel would lead to 20-30% CO<sub>2</sub> reductions, and a speed reduction mandate targeted to achieve a 20% CO<sub>2</sub> reduction in the container fleet costs between \$30 and \$200 per ton CO<sub>2</sub> abated.<sup>2</sup> Similarly, in Taiwan (Kaohsiung Port), it is found that adopting the strategies of both reduced speed and cold ironing emissions control can reduce 71% and 91% emissions with a 20 nautical mile reduced speed zone.<sup>3</sup> It is thus suggested that, the port authorities and shipping companies should invest in shore power and related transmission equipment in order to fit the trend of international ports.

With regard to developing green ports, many ports have developed corporate social responsibility strategies. In Sweden, it is suggested to implement a differentiated green port through internalizing external costs in the transportation systems and analyzing the effects of the strategy by various stakeholders.<sup>4</sup> In Hong Kong, It is indicated that green management practices (GMP) consists (1) cooperation with supply chain partners, (2) environmentally friendly operation, and (3) internal management support. Also in Hong Kong, it was found that a positive relationship exists between the adoption of GMP and container terminal firm performance.<sup>5</sup> Recently,, the research of Netherlands found clean shipping target difficult to achieve through private governance institution due to an insufficient level of collaborative advantage within partnership with related political and legal issues.<sup>6</sup> For example, The Marine Environment Pollution Committee (MEPC), a sub-organization of International Maritime Organization, is responsible for drawing up relevant regulations to prevent ships from polluting the ocean and atmosphere. MEPC started examining ships' air pollution since year 1988 through the regulation of Prevention of Air Pollution from Ships or MARPOL. 73/78 Annex VI. In China, a general algebraic modeling system was tested in the green port project scheduling with comprehensive efficiency consideration and found that efficiency achievement is significant from

---

<sup>1</sup> Dimitrios Georgakellos, The Use of the Deposit-refund Framework in Port Reception Facilities Charging Systems, *Marine Pollution Bulletin*, Vol. 54, 2007, pp. 508~520.

<sup>2</sup> James Corbett, Haifeng Wang and James Winebrake, The Effectiveness and Costs of Speed Reductions on Emissions from International Shipping, *Transportation Research Part D: Transport and Environment*, Vol. 14, 2009, pp. 593~598.

<sup>3</sup> Ching-Chih Chang and Chih-Min Wang, Evaluating the Effects of Green Port Policy: Case Study of Kaohsiung Harbor in Taiwan, *Transportation Research Part D: Transport and Environment*, Vol. 17, 2012, pp. 185~189.

<sup>4</sup> Rickard Bergqvist and Niklas Egels-Zanden, Green port dues- The case of hinterland transport, *Research in Transportation Business & Management*, Vol. 5, 2012, pp. 85~91.

<sup>5</sup> Lun Venus, Green Management Practices and Firm Performance: A Case of Container Terminal Operations, *Resources, Conservation and Recycling*, Vol. 55, 2011, pp. 559~566.

<sup>6</sup> Lindsey Wuisan, Judith van Leeuwen, C.S.A. and Kris Koppen, Greening International Shipping through Private Governance: A Case Study of the Clean Shipping Project, *Marine Policy*, Vol. 36, 2012, pp. 65~173.

economic and environmental perspectives.<sup>1</sup>

Evidently, the majority of these past studies mainly use quantitative approaches to survey the green port and related external cost issues, yet there is a paucity of empirical investigations that have collected stakeholder's opinion using qualitative studies, particularly in Asian countries. Despite this, qualitative approaches have been used in transport related fields, such as maritime safety<sup>2</sup> and bus transportation<sup>3</sup> and landscape and urban planning<sup>4</sup>. Nevertheless, ports, especially with regard to low emission port development, have seldom been investigated from a holistic perspective. The purpose of this study is to begin to fill this gap and present a comprehensive summarized finding after an empirical interview research.

### 3. METHODOLOGY

This study adopted qualitative approach to understand the perceptions of industry experts and governmental officers, and responses to address the complex and understudied phenomenon of low emission port policy. Based on grounded theory, qualitative analysis was used to obtain the intricate details about certain issues. To provide an in-depth understanding of low emission port development strategy, a qualitative study was undertaken in three international ports (Kaohsiung, Keelung, and Taichung) in Taiwan. The methodical approach considered interviewees' background in order to ensure their expertise (e.g. more than 10 years' work experiences or knowledge about the research topic). Interviewees were initially contacted via telephone, then selected through purposive sampling based on their ability to answer the interview questions. After confirming their participation in our research, interview location and dates were further arranged. Interviews were conducted from July 1- August 31, 2020. Every participant was sent a formal invitation letter stating that participation was voluntary and explained how the data would be used only for the purpose of the study, as well as ensuring anonymity and confidentiality. These interviews were digitally recorded and literally transcribed<sup>5</sup> using a self-chosen code<sup>6</sup>, then sent to the participants for verification.

---

<sup>1</sup> Wei Wang, Li Huang, Gu Jian and Liupeng Jiang, Green Port Project Scheduling with Comprehensive Efficiency Consideration, *Maritime Policy & Management*, Vol. 46, No. 8, 2019, pp. 967~981.

<sup>2</sup> Arben Mullai and Ulf Paulsson, A Grounded Theory Model for Analysis of Marine Accidents, *Accident Analysis and Prevention*, Vol. 43, 2011, pp. 1590~1603. U. M. Ikeagwuani and G.A. John, Safety in Maritime Oil Sector: Content Analysis of Machinery Space Fire Hazards, *Safety Science*, Vol. 51, 2013, pp. 347~353.

<sup>3</sup> Rui Carreira, Lia Patricio, Renato Natal Jorge, Chris Magee and Qi Van Eikema Hommes, *Transport Policy*, Vol. 25, 2013, pp. 233~243.

<sup>4</sup> Erin Heacock and Justin Hollander, A Grounded Theory Approach to Development Suitability Analysis, *Landscape and Urban Planning*, 100, 2011, pp. 109~116.

<sup>5</sup> Joseph Alex Maxwell, Understanding and Validity in Qualitative Research, *Harvard Educational Review*, Vol. 62, No. 3, 1992, pp. 270~300.

<sup>6</sup> Christina Davidson, Transcription: Imperatives for Qualitative Research, *The International Journal of Qualitative Methods*, Vol. 8, No. 2, pp. 35~62. Blake D. Poland, Transcription Quality. In Jaber F. Gubrium and James A. Holstein, *Handbook of Interview Research*. Thousand Oaks, Calif: Sage Publications, 2001.

Interviews were conducted in Chinese<sup>1</sup> and then translated using a decentering technique<sup>2</sup> or skopos approach<sup>3</sup> to render a translation that was as natural as possible. Data collection involved various observation and interviews (including sixteen interviewees). The participants were from organizations comprising Taiwan International Ports Limited Company (including Kaohsiung, Keelung and Taichung), Maritime Ports Bureau (including North Maritime Affairs Center, Central Maritime Affairs Center, South Maritime Affairs Center). To cover various factors of variability in low emission port development, the sixteen interviewees included director (2), port operation managers (6), terminal operators (6) and other interested parties (2) to better understand the policy implication.

Questions were both semi-structured and open ended<sup>4</sup> and based on key areas in the quantitative literature such as air pollution, regulation, international conventions, MARPOL, carbon tax, flag of convenience, port, terminal, shipping lines and shippers. These processes enhance the content of data analysis and theory development. Interview data was analyzed through initial and focused coding. The codes were developed to related themes and concepts, and selective coding further generated the formation of theoretical propositions. The interview coding brief and examples are shown in the Appendix.

#### 4. RESULTS AND DISCUSSION

Policy actions for controlling and reducing air pollution can be grouped into regulatory requirements and market-based (or incentive-based) categories<sup>5</sup>. The perceptions of the interviewees from this study has been categorized into four mitigation strategies.

##### 4.1 Adopt Economic Incentives to Mitigate Emissions

From an economic viewpoint, interviewees felt pollution externalities were social costs that should be borne by both suppliers and users of ships and trucks.<sup>6</sup> To internalize these costs a Pigouvian Tax<sup>7</sup> should be imposed on polluting activities thereby reducing

---

<sup>1</sup> Martin Cortazzi, Nick Pilcher and Lixian Jin, Language Choices and 'blind shadows': Investigating Interviews with Chinese Participants. *Qualitative Research*, Vol. 11, No. 5, 2011, pp. 505-535.

<sup>2</sup> O. Werner and D. Campbell, Translating, Working through Interpreters, and the Problem of Decentering. In R. Naroll & R. Cohen (eds.). *A Handbook of Method in Cultural Anthropology*. New York: Natural History Press. 1970.

<sup>3</sup> Hans J. Vermeer, Skopos and Commission in Translational Action. In L. Venuti (ed.) *The Translation Studies Reader* (2<sup>nd</sup> edition), London: Routledge, 2004.

<sup>4</sup> William Foddy, *Constructing Questions for Interviews and Questionnaires: Theory and Practice in Social Research*. Cambridge University Press, 1993.

<sup>5</sup> Chengfeng Wang, C., James J. Corbett and James J. Winebrake, Cost-effectiveness of Reducing Sulfur Emissions from Ships, *Environmental Science & Technology*, Vol. 41, No. 24, 2007, pp. 8233-8239. Vytautas Paulauskas, The Method to Decrease Emissions from Ships in Port Areas, *Sustainability*, Vol. 12, No. 11, 2020, pp.11~15.

<sup>6</sup> Alvar Mjelde, Øyvind Endresen, Einar Bjørshol, Caroline Wang Gierløff, Even Husby, Johanne Solheim, Narve Mjøs and Magnus S. Eide, Differentiating on Port Fees to Accelerate the Green Maritime Transition, *Marine Pollution Bulletin*, Vol. 149, 110561. DOI: 10.1016/j.marpolbul.2019.110561

<sup>7</sup> A. C. Pigou, *Economics of Welfare*. London, UK: Macmillan and Co., 1920.

ships and trucks non-optimal activity, i.e., an activity whose marginal social costs exceed its marginal social benefits. Since a ship's emission depends on how long the ship is at berth, given technology, time is a key factor affecting the magnitude of pollution costs. The longer the time, the higher the pollution costs.

A key question in welfare economics is what should be done with these tax revenues. In general, revenues generated from charges could be allocated to two main purposes: The first is air quality improvement projects. For example, port authorities provide subsidies as incentives for ship owners to buy energy-efficient ship engines or to follow the rules of emission control areas (e.g. discount for berth fee). The second is to compensate a port's residents for health problems related to emission. In any case, the port authorities should impose these taxes on ship activity, which in turn will reduce pollution and provide ship owners with an incentive to reduce emission<sup>1</sup>.

#### **4.2 Use Shore-side Power to Replace Auxiliary Engines**

The interviewees suggested that shore-side power should be comprehensively implemented to replace auxiliary engines. Currently, ships' diesel auxiliary engines continue to provide the basic power electricity for lighting, ventilation, pumps, cranes, and essential equipment while they are berthed<sup>2</sup>. One alternative to control ships' emissions is to provide the electricity supply with universal plug equipment from the land instead of from ship engines<sup>3</sup>. Several successful cases have been implemented in different ports where shore-side electrical power has achieved significant reduction in CO<sub>2</sub> emissions: 99.5%, 85.0%, and 9.4% in Norway, France and the U.S., respectively<sup>4</sup>. To encourage such a system, a port tax discount (or differentiated tonnage tax) could be implemented for ships when they use shore-side power. However, there are currently no compulsory rules that could guide ship owners to adopt shore power in Taiwan ports. Again, shore power is not installed in many old ships due to high expenses of ship-side equipment, hence such old ships cannot be deployed to advanced ports (e.g. US). Also, the adoption of shore power might sometimes depend on the rules of Flag of Convenience. The development pace is evident in Taiwan when compared to other advanced ports (e.g. Hong Kong, Singapore, Los Angeles, Long Beach). Ships currently being constructed are more likely to be equipped with shore power facilities so the adoption rate could increase in the future.

#### **4.3 Improve Operation Efficiency in Port**

A third strategy interviewees noted was to improve operations efficiency in port.

---

<sup>1</sup> Celeste Ahi, Elaine Frey and Seiji Steimetz, The Effects of Financial Incentives on Vessel Speed Reduction: Evidence from the Port of Long Beach Green Flag Incentive Program, *Maritime Economics & Logistics*, Vol. 19, No. 4, 2017, pp. 601~618.

<sup>2</sup> Jihong Cheng, Tianxiao Zheng, Akhil Garg, Lang Xu, Sifan Li and Yijie Fei, Alternative Maritime Power application as a green port strategy: Barriers in China, *Journal of Cleaner Production*, Vol. 213, 2019, pp. 825~837.

<sup>3</sup> Markus Salomon, Recent European Initiatives in Marine Protection Policy: Toward Lasting Protection for Europe's Seas? *Environment Science & Policy*, Vol. 12, 2009, pp. 359~366.

<sup>4</sup> Willaim Hall, Assessment of CO<sub>2</sub> and Priority Pollutant Reduction by Installation of Shoreside Power, *Resources, Conservation and Recycling*, Vol. 54, 2010, pp. 462~467.

Since ship time at berth is an important factor that would affect its emissions in port, improving cargo operation efficiency (loading/unloading) by introducing advanced facilities such as container gantry cranes, rail-mounted gantry crane and container stacker at berth, could further mitigate the severity of air pollution and externality<sup>1</sup>. Currently, in order to achieve an efficient handling service, only few shipping lines use lease-dedicated berths in Taiwanese ports. Other shipping lines without berthing priority have to queue for a berthing at a public berth due to the cost implications. From a green port management perspective, the port authorities could provide more lease-dedicated berth projects with proper rent reduction to reduce ship times at berth if the ship operators were to adopt certain environmental policies; for example, using low Sulphur fuel instead of traditional maritime fuels when berthing at port<sup>2</sup>. Also, the container yard storage strategies for improving land utilization and operation efficiency should be well implemented in order to minimize the number of reshuffles/turnaround time to consequently reduce congestion in the yard.

#### 4.4 Adopt Technological Innovations to Mitigate Emissions

Interviewees believed innovation in technology provides many potential opportunities to reduce ship and truck emissions. For example, natural gas is available as a fuel source for smaller ships (e.g., tugboats and commercial fishing boats) at berth<sup>3</sup>. Also, clean fuel (e.g., fuel cell, low sulphur fuel, biodiesel, liquefied natural gas) offers many advantages over existing diesel generators, such as low exhaust emissions (e.g., diesel oxidation catalyst and diesel particulate filter), improved thermal efficiency and electrification (e.g., automated vehicles and hybrid yard equipment). However, introducing new technologies (e.g. Internet of Things, big data<sup>4</sup>) might be costly for shipping operators with related bargaining power between port authorities and shipping operators.<sup>5</sup> In addition, autonomous ship might be a future trend and could significantly reduce emissions. However, besides higher construction costs, shipping laws for this technology has not been well organized by the International Maritime Organization (IMO), other internal stakeholders (e.g. member states, council, and committee) and external stakeholders (e.g. non-governmental organization). Therefore, it is necessary to integrate these advancing technologies into the existing regulation framework. Shipping operators can further collaborate and cooperate with other organizations in the region for innovation.

---

<sup>1</sup> Yi-Chih Yang, Operating Strategies of CO<sub>2</sub> Reduction for A Container Terminal based on Carbon Footprint Perspective, *Journal of Cleaner Production*, Vol. 141, 2017, pp. 472~480.

<sup>2</sup> Ching-Chin Chang and Chia-Wei Jhang, Reducing Speed and Fuel Transfer of the Green Flag Incentive Program in Kaohsiung Port Taiwan, *Transportation Research Part D*, Vol. 46, 2016, pp. 1~10.

<sup>3</sup> Lei Yang, Yiji Cai, Yunlei Wei and Shou Huang, Choice of Technology for Emission Control in Port Areas: A Supply Chain Perspective, *Journal of Cleaner Production*, Vol. 243, 2019, 118105. <https://doi.org/10.1016/j.jclepro.2019.118105>

<sup>4</sup> Xing Sun, Zhe Tian, Reza Malekian and Zhixiong Li, Estimation of Vessel Emission Inventory in Qingdao Port based on Big Data Analysis, *Symmetry*, Vol. 10, No. 10, 2018, pp. 452-1~452-11. 10.3390/sym10100452

<sup>5</sup> Dong Bo, Dong Kangcheng, Chen Guang, Cao Huiyun and Ya Hongying, Carbon Emission Management System of Port Logistics based on Internet of Things Technology, *Agro Food Industry Hi-Tech*, Vol. 28, No. 1, 2017, pp. 1094~1098.



For example, shipping authorities could help IMO and regulatory bodies to ensure ships' energy efficiency requirements to meet the rapid technological changes. Also, automated guided vehicles and automatic yard cranes in automatic container terminal system will be future development trend, especially in hub ports.<sup>1</sup> Finally, there ought to be clear guidelines and work schedules for discharging and loading operation prepared for the stakeholders (e.g. shipping operators, terminal operators, shipping agents, etc.) with the utilization of carbon trading mechanism as a possible solution.<sup>2</sup>

## 5. CONCLUSION

In order to develop a low emission port, this study adopted a qualitative approach to collect and analyze various opinions for port stakeholders. Based on sixteen expert opinions, this qualitative approach allowed access to more in-depth perspectives and these were categorized into four mitigation strategies focusing on economic incentives, shore-side power, port operation efficiency (e.g. container yard storage strategies) and technology innovation (e.g. clean fuel, automatic operation system). It is suggested that port planning and development should consider three important stakeholders which are port/terminals, carriers and shippers. Furthermore, mitigation strategies of air pollution should be flexibly designed and managed from a broad perspective. For example, port taxes (carbon tax) should be levied by the port authorities and paid by the ship owners. It should as well increase stakeholder acceptance and provide initiatives (e.g. port tax reduction via adopting energy-saving methods) to achieve resource use rationalization (or resource sharing) and environmental balance.

## ACKNOWLEDGEMENTS

The author would like to acknowledge the National Research Council, Taiwan, ROC, for providing partial funding support under contract number MOST 105-2410-H-035-030.

## APPENDIX

Thank you very much for participating in this research project. I'll record the interview to enhance reliability. I don't know how long this will take but I estimate approximately 1 hour. Please feel free to ask questions at any time, and I may do same to help me appreciate your perspective as an interviewee. The brief coding contents are shown in Table 1.

**Table 1 Coding and exemplar quote**

Codified Category	Descriptions	Exemplar Quote
Conventions	Adopt international conventions (e.g. MARPOL) when	<i>"Shipping lines should autonomously follow international</i>

<sup>1</sup> Kap Hwan Kim and Jong Wook Bae, A Look-Ahead Dispatching Method for Automated Guided Vehicles in Automated Port Container Terminals, *Transportation Science*, Vol. 38, No. 2, 2004, pp.224~234.

<sup>2</sup> Yuxia Peng and Yanping Meng, Research on Carbon Emission Reduction Decisions of Ports with Low Carbon Preference under Carbon Trading Mechanism, *International Journal of Social Science and Education Research*, Vol. 3, No. 9, 2020, pp. 330~321.

	implementing Port State Control check	<i>conventions</i> ". Industry Expert 01.
Carbon tax	Polluters pay the pollution fees	<i>"It is reasonable that port polluter pay the carbon tax in order to reduce emission around the port area"</i> . Government Expert 01. <i>"Carbon Trading Mechanism might be a future trend"</i> . Government Expert 02.
Regulations	Adopt emission mitigation strategies (e.g. low sulfur fuel, shore power, reduced speed) to achieve green port target.	<i>"Our company will follow pollution regulation rules of port authorities even it might add our operation costs."</i> Industry Expert 02.

Editor (English) : Evans Tetteh

# 关于军舰无害通过权问题的再认识

贾宇\*

**摘要：**航行自由与无害通过交织在国际海洋法的发展中，是《公约》的重要组成部分。无害通过在内水、领海和国际海峡中均有体现。在第三次联合国海洋法会议中的立场、国内法和国家实践中，中国关于军事船舶无害通过的立场一以贯之。中国法律规定外国军事船舶通过中国领海需要事先得到中国政府的批准，这是一种附条件的无害通过。

**关键词：**《联合国海洋法公约》 军舰 无害通过 批准

## 一、从航行自由到无害通过

航行是人类利用海洋的最早方式之一。地理大发现引起了瓜分海洋的欲望和斗争。西班牙和葡萄牙划分了海上势力范围，这种霸海一方的做法成为后发国家向海发展的桎梏，受到“海上马车夫”荷兰等新兴海洋国家的挑战，打破海洋割据局面的要求日益强烈。海洋自由呈现出激烈的权利争夺的特征。

1609年，格劳秀斯在《海洋自由论》中提出，“根据国际法，任何人可以自由航行至任何地方”“任何国家到任何他国并与之进行贸易都是合法的”。<sup>1</sup>“海洋自由论”的核心思想是：海洋是人类共有之物，应向所有国家开放，任何国家不得独占海洋。所有国家都有利用海洋进行航行和海上运输的自由。到了十八世纪，许多国际法学者都主张海洋自由，这恰恰说明，彼时海洋并非绝对自由。1702年，荷兰法学家宾刻舒克将海洋区分为领海和公海，主张领海属于沿岸国的主权管辖，而公海则不属于任何国家。对海洋自由的理解聚焦于公海之上。

已经成为海洋大国的英国开始反对海洋自由。塞尔登提出海洋封闭论，主张海洋可以被占领。“国家渐不复宣告‘闭海’或征税之权利。海洋所有权渐消失。至于十八世纪，有名的公法家皆主张公海自由，而任有公海与领海之分别”。<sup>2</sup>塞尔登还首次提出了“无害通过”的概念，<sup>3</sup>这个概念逐渐得到接受，发展成当今海洋航行制度的内容之一。

---

\*贾宇，法学博士，自然资源部海洋发展战略研究所研究员。

<sup>1</sup>雨果·格劳修斯：《海洋自由论》，宇川译，华东师范大学出版社2005年版，第1页。

<sup>2</sup>周鲠生：《国际法大纲》，中国方正出版社2004版，第57页。

<sup>3</sup>寺田四郎著 韩仙译，《国际法学界之七大家》，第106页。北京：中国政法大学出版社，2003年5月第1版。

随着科技的进步,海洋在世界政治经济中发挥的作用越来越突出,欧洲列强开始率先利用工业革命积聚的优势力量进行殖民扩张,葡、西、荷、俄、英、美、德、日等先后成为海洋强国,进而发展成为世界强国。正如马克思在《共产党宣言》中所指出的,“世界市场使商业、航海业和陆路交通得到了巨大的发展。这种发展又反过来促进了工业的扩展”。<sup>1</sup>

十九世纪末,美国进入全面扩张时期。马汉的“海权论”应运而生,为美国走上称霸海洋的道路奠定了理论基础。马汉全面系统地论述了强大的舰队、繁荣的商业和海外基地的互相依存关系。马汉认为,“一个濒临海洋或者要借助于海洋来发展自己的民族,海上力量就是一个秘密武器”,是否掌控海上霸权是决定战争胜负的因素。<sup>2</sup>“控制海洋”进一步压缩了海洋自由的空间。国际海洋秩序亟待规范。

### (一) 联合国三次海洋法会议对航行自由与无害通过的规范

在国际海洋法的发展过程中,航行自由与领海的无害通过紧密相连。1958年第一次联合国海洋法会议通过的日内瓦海洋法四公约<sup>3</sup>,确立了包括航行自由在内的四大公海自由。《领海和毗连区公约》的第三节是“无害通过权”,包括“适用于所有船舶的规则”“适用于商船的规则”和“适用于军舰以外的政府船舶的规则”三个分节。《领海和毗连区公约》第14条规定:“无论是否沿海国之各国船舶依本条款之规定享有无害通过领海之权”“如不妨害沿海国之和平、善良秩序或安全即系无害通过”,这是“适用于一切船舶之规则”。<sup>4</sup>凡此,奠定了第三次联合国海洋法会议制定无害通过章节条款的基础。

包括航行自由在内的公海六大自由和领海无害通过制度,都是第三次联合国海洋法会议制定的《联合国海洋法公约》(以下简称《公约》)的重要内容。<sup>5</sup>

### (二) 第三次联合国海洋法会议关于无害通过的讨论

外国军舰无害通过沿海国领海一直是海洋法领域存有较大争议的问题,为参加第三次联合国海洋法会议的国家所高度关注。

---

<sup>1</sup> 《马克思恩格斯选集》(第一卷),人民出版社2012年版,第401页。

<sup>2</sup> 马汉:《海权论》,一兵译,北京日报出版社2012年版,第1页。

<sup>3</sup> 《领海和毗连区公约》《公海公约》《大陆架公约》《捕鱼及养护公海生物资源公约》和《关于强制解决争端的任择签字议定书》。

<sup>4</sup> 详见联合国国际法委员会网站:<http://www.un.org/chinese/law/ilc/fish.htm>。

<sup>5</sup> 《公约》第87条“公海自由”规定:1.公海对所有国家开放,不论其为沿海国或内陆国。公海自由是在本公约和其他国际法规则所规定的条件下行使的。公海自由对沿海国和内陆国而言,除其他外,包括:(a)航行自由;(b)飞越自由;(c)铺设海底电缆和管道的自由,但受第六部分的限制;(d)建造国际法所容许的人工岛屿和其他设施的自由,但受第六部分的限制;(e)捕鱼自由,但受第二节规定条件的限制;(f)科学研究的自由,但受第六和第十三部分的限制。2.这些自由应由所有国家行使,但须适当顾及其他国家行使公海自由的利益,并适当顾及本公约所规定的同“区域”内活动有关的权利。”第90条“航行权”规定:每个国家,不论是沿海国或内陆国,均有权在公海上行驶悬挂其旗帜的船舶。”

早在海底委员会期间，苏联、西班牙和马来西亚等国的发言就提出，军舰（包括潜艇）通过其领海内的海峡应事先获得准许。<sup>1</sup>

在第三次联合国海洋法会议期间，关于外国军舰无害通过沿海国领海问题的非正式和正式提案不在少数，在后期的多期会议上进行了广泛的讨论。加蓬的提案要求军舰通过领海既须事先准许，也须通知沿海国。<sup>2</sup> 另一项由 28 个国家发起的修正案建议增加“安全”的规定，以便满足发起者的关切和为更多的海洋国家所接受。<sup>3</sup> 两项提案既获得了大量的支持，也引起了激烈的辩论。反对者认为，采纳修正案会影响已经达成的微妙平衡；支持者坚持无论最终的公约条文有否明文规定，沿海国有权管理军舰的通过。这些国家在签署《公约》时再次声明，《公约》的规定不妨碍它们采取规范军舰无害通过其领海的措施的权利。

《公约》第三节的标题是“领海的无害通过”，包括三个分节：A 分节是“适用于所有船舶的规则”，B 分节是“适用于商船和用于商业目的政府船舶的规则”，C 分节是“适用于军舰和其他用于非商业目的政府船舶的规则”。这与 1958 年《领海和毗连区公约》的规定基本一致。<sup>4</sup>

第 17 条是“无害通过权”，位于 A 分节之下，规定“在本公约的限制下，所有国家，不论为沿海国或内陆国，其船舶均享有无害通过领海的权利。”包括第 17 条在内的 A 分节适用于所有船舶，并且应与第 18 条（通过的意义）、第 19 条（无害通过的意义）结合在一起解读。<sup>5</sup>

尽管《公约》第 17 条明确无害通过权的规定适用于所有国家及其船舶，争议在于外国军舰的无害通过是否应当取得沿海国的同意。大部分西方海洋大国主张军舰应享有同商船等同的无害通过权，主张军舰通过领海必须事先取得沿海国同意的国家多为发展中国家。<sup>6</sup>

海洋大国的态度也发生过较大变化。苏联在第一次海洋法会议时立场保守，但在第三次海洋法会议期间及以后，则支持军舰的无害通过权。现在，俄罗斯允许外国军舰在俄领海无害通过，但禁止 3 艘以上外国军舰和来自同一国家的外国政府船舶在同一时间通过俄领海。外国核动力船舶、军舰、其他政府船舶和运载核能或其他危险有毒物质或材料的船舶，在通过俄领海时必须是有必备文书，遵守有关此类

<sup>1</sup> Satya N. Nandan and Shabtai Rosenne, *United Nations Convention on the Law of the Sea 1982 Commentary*, Volume II, Martinus Nijhoff Publishers, 1993, p. 165.

<sup>2</sup> Satya N. Nandan and Shabtai Rosenne, *United Nations Convention on the Law of the Sea 1982 Commentary*, Volume II, Martinus Nijhoff Publishers, 1993, p. 168.

<sup>3</sup> Satya N. Nandan and Shabtai Rosenne, *United Nations Convention on the Law of the Sea 1982 Commentary*, Volume II, Martinus Nijhoff Publishers, 1993, p. 168.

<sup>4</sup> 邵津：《关于外国军舰无害通过领海的一般国际法规则》，载《中国国际法年刊》（1989），中国对外翻译出版社公司。

<sup>5</sup> Satya N. Nandan and Shabtai Rosenne, *United Nations Convention on the Law of the Sea 1982 Commentary*, Volume II, Martinus Nijhoff Publishers, 1993, p. 125.

<sup>6</sup> J. Ashley Roach & Robert W. Smith, *United States Responses to Excessive Maritime Claims*, Brill Academic Pub, 2<sup>nd</sup> ed., 1996, pp. 266-267.

船舶特殊警戒措施的国际公约，在领海的特定航道行驶，服从为其特别制定的航道分区安排。<sup>1</sup>

从国家实践看，海洋大国如美国、英国、法国、德国、意大利、荷兰、俄罗斯等多主张军舰应享有同商船等同的无害通过权，而坚持军舰必须经过沿海国的同意才能通过其领海的多为发展中国家，约有 40 个左右。<sup>2</sup>

## 二、中国关于军舰无害通过问题的立场

中华人民共和国恢复在联合国的合法席位之后，中国代表团在联合国海底委员会和第三次联合国海洋法会议上的发言中，多次阐述中国关于领海无害通过问题的一般立场。中国的国内立法和实践与此保持一致。

### （一）海底委员会时期

在海底委员会会议期间，中国代表团在发言中阐述了关于军舰无害通过的立场。中国认为，外国商船可以无害通过领海，但军舰应事先得到批准、通知或许可。中国代表团还就“无害通过”的含义阐述了中国的理解。

关于领海的无害通过问题，中国代表在海底委员会第二小组委员会会议上指出：属于各国领海范围内的海峡，不论是否经常用于国际航行，应由各沿岸国进行管理，外国商船可以无害通过，但是应该遵守各沿岸国的有关法令和制度的规定，外国军舰必须事先得到批准，才能通过属于沿岸国领海范围内的海峡。<sup>3</sup>

关于第一次联合国海洋法会议通过的《领海和毗连区公约》对无害通过问题的规定，中国代表在海底委员会第二小组委员会会议上的发言指出，《领海和毗连区公约》第 14 条只是笼统地规定各国船舶都享有无害通过领海的权利。

1973 年，在联合国海底委员会在第二届会议上，中国代表团提交了一份“关于国家管辖范围内海域的工作文件”（以下简称“工作文件”），表达中国代表团对海洋法问题的一贯立场。“工作文件”包括了中国对无害通过问题的主张。一是阐述了对“无害通过”一词含义的解释。无害通过是指不损害沿海国的和平、安全和良好秩序的通过。二是外国的非军用船舶可以无害通过领海。三是外国军用船舶通过领海，应事先通知主管机关或经主管机关事先许可。四是沿海国可以制定、公布必要的法律和规章。外国船舶和飞机通过别国领海和领海上空，应遵循该国的法律和规章。<sup>4</sup>

---

<sup>1</sup> Federal Act on the Internal Maritime Waters, Territorial Sea and Contiguous Zone of the Russian Federation, 17 July 1998, at [http://www.un.org/Depts/los/LEGISLATIONANDTREATIES/PDFFILES/RUS\\_1998\\_Act\\_TS.pdf](http://www.un.org/Depts/los/LEGISLATIONANDTREATIES/PDFFILES/RUS_1998_Act_TS.pdf), 2019 年 11 月 11 日登录。

<sup>2</sup> 详见美国国防部网站：<http://policy.defence.gov/OUSDP-Offices/FON>。

<sup>3</sup> 北京大学法律系国际法教研室：《海洋法资料汇编》，人民出版社 1974 年版，第 33 页。

<sup>4</sup> 北京大学法律系国际法教研室：《海洋法资料汇编》，人民出版社 1974 年版，第 74 页。

## （二）第三次联合国海洋法会议时期

第三次联合国海洋法会议期间，关于军舰通过领海的问题依然是争论的焦点。海洋大国和发展中国家的主张截然对立：前者主张外国军舰在沿海国领海内行使无害通过权，后者要求外国军舰须事先通知沿海国主管机关，或经该国主管机关许可之后方可通过其领海。尽管在1974年第二委员会提出的《主要趋势》的文件中纳入了反应上述两种主张的案文，但1975年第三期会议产生的《非正式单一协商案文》有关此问题的条款却只反映了海洋大国的立场，明文规定无害通过的规则适用于军舰，遭到30多个国家的反对。

1976年第四期会议产生的《订正的正式单一协商案文》删掉上述条文。此后产生的各种协商案文都沿袭了1976年的案文。

从1978年第七期会议开始，中国和其他20多个发展中国家多次提出联合提案，建议增加有关外国军舰通过沿海国的领海时应事先获得批准或予以通知的内容，以及沿海国领海的安全等问题，为《公约》的讨论和制定作出了贡献。

首先，从**军用船舶和一般商船性质**上的差别，强调无害通过只是沿海国提供的便利，应由国内法予以规范。

在1978年的第七期会议上，鉴于第六期会议产生的《非正式综合协商案文》未能反映中国代表团和其他许多国家关于军用船舶通过领海的意见，1978年4月28日，中国代表团在第二委员会非正式会议上指出：“谁都知道军用船舶和一般的商船是性质不同的两种船舶，对于外国的军用船舶要不要给予在本国领海内无害通过的便利，应该由沿海国根据自己的法律和规章来决定。”“现在《非正式综合协商案文》将一般船舶和军用船舶不加区分的写法是中国代表团完全不能接受的。”<sup>1</sup>中国案文强调了军用船舶和一般商船性质的不同，认为外国军用船舶在沿海国领海的无害通过是本国提供的一种便利，应由本国根据自己的法律和规章来决定。

在1980年的第九期会议期间，中国加入了阿根廷等国提出的非正式建议，声援发展中国的合理要求，主张沿海国有权对外国军舰通过领海制定必要的规章，“包括要求预先征得同意和通知通过领海的权利”。中国的立场表明，外国军舰通过沿海国领海的问题，属于沿海国国内法规规定的事项，内容包括预先征得沿海国的同意和通知沿海国。

**其次，提出领海的“安全”问题。**在1982年的第十一期会议上，中国等28个国家在第二委员会和全体会议上分别提出共同提案（C.2/Informal Meeting/58/Rev 1）和正式修正案（A/CONF. 62/L. 117），建议规定沿海国有权按照本国的法律和规章，要求外国军舰通过领海前应先经该国批准或通知该国。在制定关于无害通过领海的法律和规章时，所涉事项应包括沿海国的“安全”。

鉴于共同提案国和反对国在这一问题上的尖锐对立，为避免会议破裂，双方同意不再坚持提付表决而由大会主席在全体会议上做出声明，“不妨碍沿海国按照公

<sup>1</sup> 《我国代表团出席联合国有关会议文件集》（1978.1-6），人民出版社1978版，第131-132页。

约第 19 条（领海无害通过的意义）和第 25 条（沿海国的保护权）的规定，采取措施以保证其安全的权利”。最后，《公约》关于领海无害通过的条款与 1958 年《领海和毗连区公约》几无差别。

1982 年 3 月 31 日，中国代表团在发言中再次强调，军舰通过领海的制度问题“关系到沿海国的主权和安全，受到许多国家的重视”。<sup>1</sup>鉴于目前公约草案中的有关规定不明确，未来在解释和执行上可能产生分歧，中国和有关国家提出一项共同提案，建议增加一项条款，规定沿海国按照本国法律和规章，要求外国军舰通过领海事先经该国批准或通知该国。

**最后，在签约之际再次重申关于无害通过的立场。**在 1982 年 4 月 30 日通过公约的会议上，中国代表团在发言中重申：“本公约有关领海内无害通过的规定，不妨碍沿海国有权按照本国法律和规章，要求外国军舰通过领海事先须经该国批准或通知该国。”<sup>2</sup>

1982 年 12 月 9 日，在第三次海洋法会议最后会议签署公约时，中国代表团在发言中再次声明：“在过去历期会议上，我们曾多次指出，公约有关领海无害通过的条款中对军舰通过领海的制度未作明确的规定，包括中国在内的不少国家曾多次提出修正案。在今年四月的会议上，为了响应会议主席的呼吁，以便会议能以协商一致方式通过公约草案，上述共同提案国没有坚持要求将该修正案提付表决。但当时会议主席所作的声明已经表明，这并不影响共同提案国要求保障本国安全的原则立场。”<sup>3</sup>

总之，在第三次联合国海洋法会议期间，中国的立场旗帜鲜明，从未动摇：军事船舶与商船性质不同，沿海国有权对外国军舰通过领海制定必要的规章，外国军事船舶通过沿海国的领海需要事先得到批准或事先通知该国。

大会主席在第九期全体会议上的声明，明确不妨碍沿海国按照公约有关规定，采取措施以保证其安全的权利。

### 三、中国关于无害通过的国内法和国家实践

在《公约》谈判过程中、中国签署和批准《公约》以及《公约》对中国生效后，中国一贯坚持外国军舰通过领海需要事先经过中国明确的同意。这种同意表现为“许可”和“批准”（或“通知”）。

---

<sup>1</sup> 国家海洋局政策研究室：《各国领海及毗连区法规选编》，法律出版社 1985 年版，第 193-194 页。

<sup>2</sup> 《中国代表团出席联合国有关会议文件集》（1982. 1-6），世界知识出版社 1983 年版，第 91 页。

<sup>3</sup> 国家海洋局政策研究室：《各国领海及毗连区法规选编》，法律出版社 1985 年版，第 195 页。



## （一）许可与批准

1958年9月4日，第一届全国人民代表大会常务委员会第100次会议批准通过了《中华人民共和国政府关于领海的声明》（以下简称《领海声明》），要求无害通过中国领海的外国军舰要事先得到中国政府的许可。<sup>1</sup>

《领海声明》第三项明确规定：“一切外国飞机和军用船舶，未经中华人民共和国政府的许可不得进入中国的领海和领海上空”。值得注意的是，《领海声明》中的“许可”，对所有外国飞机和军用船舶是一体适用的。

中国相关国内法中关于外国军舰无害通过中国领海的要求是事先得到中国政府的批准。新中国涉及无害通过的第一部国内法是《中华人民共和国海上交通安全法》（以下简称《海上交通安全法》）。1983年9月2日通过的《海上交通安全法》第11条第2款规定：“外国籍军用船舶，未经中华人民共和国政府批准，不得进入中华人民共和国领海。”<sup>2</sup>

1992年2月25日《中华人民共和国领海及毗连区法》第6条第2款再次规定：“外国军用船舶进入中华人民共和国领海，须经中华人民共和国政府批准。”<sup>3</sup> 1991年10月25日，时任国家海洋局局长严宏谟，在第七届全国人民代表大会常务委员会第22次会议上所作《关于〈中华人民共和国领海及毗连区法（草案）〉的说明》（以下简称《说明》），在“关于外国船舶通过领海的制度”中认为，“鉴于我国现实情况，《草案》采取了外国军用船舶通过领海的批准制度。《草案》第六条第二款规定，外国军用船舶进入中华人民共和国领海，须经中华人民共和国政府批准”。《说明》还认为，“这样规定与我国1958年‘关于领海的声明’和1983年〈海上交通安全法〉的规定是一致的”。<sup>4</sup>

笔者认为，全国人民代表大会常务委员会批准通过的《领海声明》和中国相关国内法中关于外国军舰无害通过中国领海的要求，事先许可到事先批准，本质上都是要求事先的明确同意。但“许可”和“批准”还是有一定差异的。《说明》所谓《草案》采取的外国军用船舶通过领海的批准制度与我国1958年《领海声明》的规定相一致的说法，未尽准确。

至于法律草案说明的性质，应属法律草案的起草部门向全国人大或常委会提请审议的汇报，包括介绍和说明起草背景、过程、法律草案的主要内容、拟建立的主

<sup>1</sup> 《中华人民共和国政府关于领海的声明》第3项。中国人大网：[http://www.npc.gov.cn/wxzl/gongbao/1958-09/04/content\\_1480851.htm](http://www.npc.gov.cn/wxzl/gongbao/1958-09/04/content_1480851.htm)，2019年12月9日登录。

<sup>2</sup> 《中华人民共和国海上交通安全法》，中国人大网：[www.npc.gov.cn/wxzl/gongbao/2000-12/06/content\\_4434.htm](http://www.npc.gov.cn/wxzl/gongbao/2000-12/06/content_4434.htm)，2019年12月9日登录。

<sup>3</sup> 《中华人民共和国领海及毗连区法》第6条第2款，中国人大网：[http://www.npc.gov.cn/wxzl/wxzl/2000-12/05/content\\_4562.htm](http://www.npc.gov.cn/wxzl/wxzl/2000-12/05/content_4562.htm)，2019年12月9日登录。

<sup>4</sup> 《关于〈中华人民共和国领海及毗连区法（草案）〉的说明》，中国人大网：[http://www.npc.gov.cn/wxzl/gongbao/2000-12/14/content\\_5002675.htm](http://www.npc.gov.cn/wxzl/gongbao/2000-12/14/content_5002675.htm)，2019年12月9日登录。

要制度等。或许在一定程度上能够反应立法本意，但这种说明本身并非立法解释，应无法律效力。

## （二）许可与通知

1996年5月15日，第八届全国人民代表大会常务委员会第十九次会议关于批准《公约》的决定指出：“中华人民共和国重申：《联合国海洋法公约》有关领海内无害通过的规定，不妨碍沿海国按其法律规章要求外国军舰通过领海必须事先得到该国许可或通知该国的权利”。<sup>1</sup>

这个决定有以下几层含义：第一，中国作为签署和批准《公约》的沿海国，可以就领海的无害通过问题制定相应的法律和规章；第二，这些法律和规章中可以包括关于外国军舰通过中国领海必须事先得到中国政府的许可或通知中国政府的要求。

鉴于“决定”中的“许可”与“通知”之间的连词是“或”，表示二者择其一，并且《领海及毗连区法》和《海上交通安全法》中并没有关于外国军舰通过中国领海必须事先通知中国政府的规定，可以认为，事先通知并非中国国内法的选项。

## （三）中国关于无害通过的实践

中国关于领海无害通过的国家实践，主要体现在对外国军舰擅入领海行为的抗议和批驳。

1958年《领海声明》发表后，美国军用舰机继续侵犯中国领海、领空，中国不断提出抗议。1958年9月7日，外交部对美国军舰侵入中国领海提出严重警告。1960年5月25日，美国军舰侵入中国福建沿海。5月27日，中国政府对美国提出第100次警告。1962年4月26日，美国军舰两次侵入中国西沙群岛水兴岛附近海域，中国政府向美国提出第200次严重警告。从1958年9月7日到1964年7月1日，计有315艘美国军舰侵犯中国领海201次、405架美国飞机侵犯中国领空233次。1969年6月23日，中国就整机整舰侵犯中国领海、领空提出第469次严重警告。<sup>2</sup>

近年来，美国军事船舶多次擅自进入中国西沙群岛领海，<sup>3</sup>或在南沙群岛南熏礁、赤瓜礁等岛礁的12海里范围内航行。<sup>4</sup>中国守岛部队和海军舰机采取应对行动，

---

<sup>1</sup> 《全国人民代表大会常务委员会关于批准〈联合国海洋法公约〉的决定》第四项，1996年5月15日通过。中国人大网：[www.npc.gov.cn/wxzl/gongbao/2000-12/16/content\\_5003571.htm](http://www.npc.gov.cn/wxzl/gongbao/2000-12/16/content_5003571.htm)，2019年12月9日登录。

<sup>2</sup> 参见：“面对美军入侵 1969年中方“提出第469次严重警告”，<http://www.xixik.com/content/e2f11b5356193849>，2019年9月26日登录。

<sup>3</sup> “国防部新闻发言人杨宇军就美国军舰擅自进入我西沙领海发表谈话”，国防部网站：[http://www.mod.gov.cn/affair/2016-01/30/content\\_4638339.htm](http://www.mod.gov.cn/affair/2016-01/30/content_4638339.htm)，2019年12月16日登录。

<sup>4</sup> “2019年5月6日外交部发言人耿爽主持例行记者会”，外交部网站：[https://www.fmprc.gov.cn/web/wjdt\\_674879/fyrbt\\_674889/t1661103.shtml](https://www.fmprc.gov.cn/web/wjdt_674879/fyrbt_674889/t1661103.shtml)，2019年12月16日登录。

对美军舰进行识别查证,警告驱离。中国国防部对美舰行为表示坚决反对,强调《领海及毗连区法》规定外国军舰进入我国领海,必须经过事先批准。

美军舰多次径行进入、穿越南沙群岛岛礁邻近海域,多次进入、穿越西沙群岛领海,甚至在一些岛礁的12海里内停留、进行救生训练。<sup>1</sup>在领海水域内刻意停留、进行救生训练等“与通过没有直接关系”的行动,是明显的“非无害通过”。

美军舰未经中国政府批准,擅入南海岛礁领海,这是在以实际行动表明美国历来坚持的军事船舶在他国领海的无害通过权——无需事先通知或得到批准。刻意进行非无害通过的行动,则表明对美国不承认中国西沙群岛的直线基线。

中国外交部、国防部的抗议和批驳,都是针对美舰违反中国法律、未经批准,擅自进入中国领海,并不是批判美舰没有无害通过权。

#### 四、中国学界的观点

关于军舰的无害通过权问题,中国学界主要有两种观点:肯定论者和否定论者。

##### (一) 肯定论

肯定论者认为,军舰同商船一样享有领海的无害通过权,无需事先得到沿海国的批准、许可或事先通知沿海国。理据在于:《公约》第17条“无害通过权”规定,“所有国家,不论为沿海国或内陆国,其船舶均享有无害通过领海的权利”。该条位于A分节“适用于所有船舶的规则”之下。《公约》并未区分商船或军事船舶,也未规定军事船舶不属于船舶从而不适用。因而,所有国家的所有船舶均享有领海的无害通过权。

肯定论者进而认为,A分节是第三节“领海的无害通过”的三个分节之首,是一般性普遍性条款,是适用于B、C两个分节的具体条款。综合三个分节的内容,应认为军舰可以与普通商船一样享有无害通过权。<sup>2</sup>在A分节中“包括了要求潜水艇和其他潜水器在水面航行的规则,其实赋予了潜水艇无害通过权。在公约制订时潜水艇只是军事船只,潜水艇被赋予无害通过权表明军舰也被赋予了无害通过权”。<sup>3</sup>并且,位于A分节的第24条“沿海国的义务”还规定,沿海国在适用《公约》或依《公约》制定的任何法律或规章时,不应“对外国船舶强加要求,其实际后果等于否定或损害无害通过的权利”。

肯定论者还援引1958年《领海及毗连区公约》来论证《公约》规定了包括军舰在内的所有船舶的无害通过权。“1958年《领海公约》规定,一切国家的船舶,

<sup>1</sup> “国防部新闻发言人吴谦就美舰擅自进入中国西沙群岛领海答问”,中国军网:  
[http://www.81.cn/xwfy/2018-05/27/content\\_8044121.htm](http://www.81.cn/xwfy/2018-05/27/content_8044121.htm)。另见:“美国两艘军舰闯入西沙群岛12海里以内,实施机动演习”,<https://new.qq.com/omn/20180527/20180527A1GT2Z00>,2019年12月18日登录。

<sup>2</sup> 陈振国:《论领海的无害通过权》,载《政治与法律》1985年第1期,第31-34页。

<sup>3</sup> 李红云:《也谈外国军舰在领海的无害通过权》,载《中外法学》1988年第4期,第88-92页。

不分军用或民用，都享有‘无害通过’领海的权利……现在的公约虽对军舰的通过作了一些进一步的限制，但基本上仍沿袭了1958年《领海公约》的规定。”<sup>1</sup>“两个公约关于领海无害通过的基本规定是相同的或几乎相同的。”<sup>2</sup>因而，外国军舰在领海享有无害通过权。

## （二）否定论

否定论者认为，军舰不享有无害通过权。“无害通过权一般只适用于商船，军舰不享有这个自由”“肯定商船的无害通过权，同时否定军舰的通过权，是代表正确的理论，也符合国际的实践的”。<sup>3</sup>如果“按照1958年日内瓦会议通过的《领海及毗连区公约》的规定，则无害通过权对一切国家的船舶，不分军舰商船，一律适用。这肯定不能代表一般国际实践，不是一切国家所能接受的规则”。<sup>4</sup>

有趣的是，这个关于1958年《领海及毗连区公约》不分军舰或商船都享有无害通过权的观点，被用来证明《公约》也做出了同样或基本同样的规定，但却忽略作者否定这种观点代表了一般国际实践，进而认为作者赞同军舰的无害通过权，其实是对作者的误读。

反对论者还认为，鉴于军用船舶通过领海和一般商船的通过根本不能等量齐观，《公约》“关于军舰通过领海的制度，显然是不符合一般接受的国际法理论和实践的”。<sup>5</sup>

无论是中国现行法律法规，还是最高权力机构的决定，抑或学界观点，都强调军舰通过领海要事先批准或事先通知，但都没有明确回答究竟中国是否承认军舰的无害通过权。

笔者认为，“批准”的前提是认同对方有某种权利，但行使这种权利要经过申请和批准。中国的立法虽未名言，但法律逻辑和国家实践是认同外国军舰在中国领海享有无害通过权的，这是一种附条件的无害通过权——外国军舰行使在中国领海的无害通过权之前，必须向中国政府申请并得到中国政府的批准。这也意味着，如果没有得到中国政府的批准，就不能进入中国领海及在中国领海内航行。正如王铁崖先生所言，“按照公认的国际法原则，沿海国家可以要求事先准许或通知，作为外国军舰通过其领海的条件”。<sup>6</sup>

在沿海国领海进行无害通过的军舰，应遵守沿海国关于通过领海的法律和规章。如果任何军舰违法沿海国关于领海的法律和规章，而且不顾沿海国向其提出遵守

---

<sup>1</sup> 沈韦良、许光建：《第三次联合国海洋法会议和海洋法公约》，载《中国国际法年刊》（1983），第410-411页。中国对外翻译出版公司。

<sup>2</sup> 邵津：《关于外国军舰无害通过领海的一般国际法规则》，载《中国国际法年刊》（1989），第12页。中国对外翻译出版社公司。

<sup>3</sup> 周鲠生：《国际法》（上册），商务印书馆1976年版，第370页。

<sup>4</sup> 周鲠生：《国际法》（上册），商务印书馆1976年版，第370页。

<sup>5</sup> 刘楠来 周子亚：《国际海洋法》，海洋出版社1986年版，第81页。

<sup>6</sup> 邓正来：《王铁崖文选》，中国政法大学出版社2003年版，第336页。

法律和规章的任何要求，沿海国可要求该军舰立即离开其领海。外国军舰不遵守沿海国有关领海的法律和规章或不遵守《公约》的规定或其他国际法规则，而使沿海国遭受任何损失或损害，船旗国应负国际责任。

## 五、结论

《公约》第29条将“军舰”定义为“属于一国武装部队、具备辨别军舰国籍的外部标志、由该国政府正式委任并名列相应的现役名册或类似名册的军官指挥和配备有服从正规武装部队纪律的船员的船舶”。可见，军舰是船舶的一种。

从海底委员会到第三次联合国海洋法会议，关于军舰无害通过权问题的讨论，是围绕是否需要事先取得沿海国的同意（如许可、批准）或事先通知沿海国进行的，而不是围绕军舰有无无害通过权问题进行的。海洋大国坚持军舰的通过无需沿海国的同意或事先通知沿海国；发展中国家则主要从国家安全的角度，要求事先取得沿海国的同意或通知沿海国。显然，这种主张并非否认外国军舰有无害通过沿海国领海的权利，而是对这种权利附加条件，即事先取得沿海国的许可、批准或事先通知沿海国。特别是批准、事先通知的要求，不可能建立在否认外国军舰享有无害通过权的基础之上。换言之，如果不承认外国军舰的无害通过权，就谈不到批准其通过的问题，外国军舰难以仅凭一纸通知就获得这种权利。

有观点认为，关于军舰的无害通过权主要有三种情况：无害通过制度、事先通知制度和批准制度。中国实行的是批准制度。<sup>1</sup>然而，无论是海底委员会期间还是第三次联合国海洋法会议期间，批准都没有作为一种规范军舰无害通过的制度予以讨论。有关提案都是将批准、许可或通知作为外国军舰行使无害通过权的条件提出和讨论的。

就中国的立法和实践而言，从1958年《领海声明》到1983年《海上交通安全法》，再到1992年《领海及毗连区法》，关于军舰在领海的无害通过，中国的立场一贯要求事先的明确同意：中国承认并尊重包括《公约》在内的国际法关于军舰在沿海国领海内的无害通过权；但是，外国军舰通过中国的领海要事先取得中国政府明确的同意，这种同意最初表现为“许可”，在《海上交通安全法》和《领海及毗连区法》中表现为“批准”，这是一种附条件的无害通过权。

这种“批准”至少包括如下几层含义：第一，中国承认外国军舰在中国领海的无害通过权；第二，拟将通过中国领海的外国军舰向中国政府有关部门提出无害通过中国领海的申请；第三，有关部门对此等申请进行审批；第四，获得批准的外国军舰按照批准的条件或要求通过中国领海。未获批准的则不得通过。

具有法律性质的1958年《领海声明》、相关国内法（《海上交通安全法》《领海及毗连区法》）和全国人大批准《公约》的决定，都强调外国军舰通过中国的领海要事先取得中国政府的批准。换言之，只有中国政府（或者中国政府授权的有关部门）才有权利接受、审批外国军舰的无害通过申请。

---

<sup>1</sup> 段洁龙：《中国国际法实践与案例》，法律出版社2011年版，第111页。

# Rethink About the Right of Innocent Passage of Warships

JIA Yu\*

Institute for Ocean Development Strategy (Beijing) of Ministry of Natural Resources

**Abstract:** Freedom of navigation and innocent passage are intertwined with the development of the International Law of the Sea. They are important components of the United Nations Convention on the Law of the Sea (UNCLOS). The concept of innocent passage is reflected in internal waters, the territorial sea and international straits. China's attitude towards innocent passage of warships has been consistent in accordance with the Third United Nations Conference on the Law of the Sea, in its domestic law and its practices. According to Article 6 of the Law of the People's Republic of China on *the Territorial Sea and the Contiguous Zone*, foreign ships for military purposes shall be subject to approval by the Government of the People's Republic of China for entering the territorial sea of the People's Republic of China, which is a kind of conditional innocent passage.

**Key Words:** United Nations Convention on the Law of the Sea warships  
Innocent passage approval

## 1、 From freedom of navigation to innocent passage

Navigation was one of the earliest ways in which man used the sea. The Age of Discovery gave rise to the desire to divide the seas and struggle. Spain and Portugal divided the maritime sphere of influence, and this hegemony over the sea became a hindrance in the development of sea faring activities in other countries and was challenged by new maritime countries, such as the Netherlands - the "maritime coachman", and the demand for breaking the monopoly over the sea became increasingly strong. The freedom of the seas has been characterized by a fierce struggle for rights.

In 1609, Hugo Grotius argued in his book *Mare Liberum* that "By the Law of Nations navigation is free to all persons whatsoever" and that "Every nation is free to travel to every other nation, and to trade with it."<sup>1</sup> The core idea of "the freedom of the seas" is that the seas belong to all mankind and should be open to all nations. No nation can have exclusive use of the seas. Freedom of navigation and maritime transport is enjoyed by all states. By the eighteenth century, many scholars of international law have advocated for

---

\* JIA Yu, Ph.D. in Law, a research staff at Ministry of Natural Resources China Institute for Marine Affairs.

©THE AUTHOR AND MARINE LAW AND POLICY

<sup>1</sup> (Netherlands) Hugo Glausius, *Mare Liberum/the Freedom of the Seas*, East China Normal University Press, 2005,1.

the freedom of the seas, which just shows that the sea was not absolutely free at that time. In 1702, the Dutch jurist Cornelius van Bynkershoek distinguished between the territorial sea and the high seas, arguing that the territorial sea was under the sovereign jurisdiction of coastal states, while the high seas belonged to no state. The understanding of the freedom of the seas focused on the high seas.

At that time, Britain became a maritime power and began to oppose freedom of the seas. In 1618, John Selden introduced the doctrine that the sea was as subject to a country's private dominion as land in his book *Mare Clausum*: "States were losing the right to declare 'closed seas' or to levy taxes. Ownership of the sea was disappearing. In the eighteenth century, all well-known publicists advocated the freedom of the high seas, and there was no distinction between the high seas and the territorial sea."<sup>1</sup> Selden proposed the concept of "innocent passage" for the first time.<sup>2</sup> It was gradually accepted and developed into one of the elements of today's maritime navigation regime.

With the progress of science and technology, the sea plays an increasingly important role in the world's politics and economics. European powers began to take the lead by using the superior forces accumulated by the Industrial Revolution for colonial expansion. Portugal, Spain, the Netherlands, Russia, Britain, the United States, Germany and Japan became maritime powers and then evolved into world powers. As Marx pointed out in the *Communist Manifesto*: "This market has given an immense development to commerce, to navigation, to communication by land. This development has, in its turn, reacted on the extension of industry."<sup>3</sup>

At the end of the nineteenth century, the United States entered a period of fullmaritime expansion. Alfred Thayer Mahan's "The Influence of Sea Power" came into being, laying a theoretical foundation for the United States to embark on the path of sea domination. Mahan comprehensively and systematically discussed the relationship of a powerful fleet, prosperous commerce and overseas bases. According to him, "a nation on the verge of the sea or to develop itself with the help of the sea is a trump card", and that maritime hegemony is the decisive factor in winning or losing the war.<sup>4</sup> The "control of the sea" has further reduced the space for freedom of the sea. Hence, the international maritime order needs to be regulated urgently.

### **1.1 Freedom of navigation and innocent passage from the Third United Nations Conference on the Law of the Sea**

When implementing the norms of international law of the sea, freedom of navigation and innocent passage through the territorial sea share a close relationship. In 1958, the four Geneva Conventions on the Law of the Sea<sup>5</sup> were adopted at the First United Nations Conference on the Law of the Sea, which established the freedom of navigation, including freedom of the four major high seas. Section III of the *Convention on the High Seas and the Contiguous Zone Convention* were divided into three parts: subsection A provides rules which are applicable to all ships, subsection B mentions rules applicable to merchant

---

<sup>1</sup> Chou Ken-sheng, *Outline of International Law*, China Founder Publishing House, 2004 edition, p. 57.

<sup>2</sup> Shiro Terada, translation by Han Xian, *Seven Masters of International Law*, P. 106. BEIJING: China University of Political Science and Law Press, May 2003 First Edition.

<sup>3</sup> *Marx/Engels Collected Works*, Volume I, People's Publishing House, 2012, p. 401.

<sup>4</sup> Mahan, *The Influence of Sea Power*, trans. Yibing, Beijing Daily Press, 1(2012).

<sup>5</sup> The Convention on the Territorial Sea and the Contiguous Zone, the Convention on the High Seas, the Convention on the Continental Shelf, the Convention on Fishing and the conservation of the Living Resources of the High Seas and the Convention on Optional Protocol on Dispute Settlement.

ships and subsection C contains rules applicable to government ships other than warships. Article 14 of the *Convention on the Territorial Sea and the Contiguous Zone* mentions that “Subject to the provisions of these articles, ships of all States, whether coastal or not, shall enjoy the right of innocent passage through the territorial sea.” and that “Passage is innocent so long as it is not prejudicial to the peace, good order or security of the coastal State.”<sup>1</sup> All of these belong to Subsection A, namely rules applicable to all ships. Thus, based on the Convention, chapter on innocent passage was formulated in the Third United Nations Conference on the Law of the Sea.

Freedom of high seas, including freedom of navigation, and innocent passage through the territorial sea are important elements on *the United Nations Convention on the Law of the Sea* (hereinafter referred to as “the Convention”), which was adopted by the Third United Nations Conference on the Law of the Sea.<sup>2</sup>

### **1.2 Deliberations on innocent passage at the Third United Nations Conference on the Law of the Sea**

The innocent passage of foreign warships through the territorial seas of coastal States has always been a highly controversial issue and was of great concern to the States participating in the Third United Nations Conference on the Law of the Sea.

As early as the Seabed Committee, statements by the Soviet Union, Spain and Malaysia suggested that warships (including submarines) should obtain prior authorization for passage through straits within their territorial sea.<sup>3</sup>

During the Third United Nations Conference on the Law of the Sea, several informal and formal proposals were put forward on innocent passage of foreign warships through the territorial sea of coastal States, which were extensively discussed at sessions. The Gabonese Republic’s proposal requires both prior authorization and notification to the coastal State for the passage of warships through the territorial sea.<sup>4</sup> The other was issued by 28 countries. The amendments proposed in 1998 proposed the addition of a “security” provision to satisfy the sponsors.<sup>5</sup> Both proposals received considerable support and triggered intense debate. Opponents argued that the adoption of the amendments would affect the delicate balance that had been struck; while supporters insisted on the right of the coastal State to regulate the passage of warships, whether or not the provisions of the

---

<sup>1</sup> See the UN International Law Commission website: <http://www.un.org/chinese/law/ilc/fish.htm>

<sup>2</sup> Article 87 Freedom of the High Seas of the Convention. 1. The high seas are open to all States, whether coastal or land-locked. Freedom of the high seas is exercised under the conditions laid down by this Convention and by other rules of international law. It comprises, inter alia, both for coastal and land-locked States: (a) freedom of navigation; (b) freedom of overflight; (c) freedom to lay submarine cables and pipelines, subject to Part VI; (d) freedom to construct artificial islands and other installations permitted under international law, subject to Part VI; (e) freedom of fishing, subject to the conditions laid down in section 2; (f) freedom of scientific research, subject to Parts VI and XIII. 2. These freedoms shall be exercised by all States with due regard for the interests of other States in their exercise of the freedom of the high seas, and also with due regard for the rights under this Convention with respect to activities in the Area. Article 90 Right of navigation refers to Every State, whether coastal or land-locked, has the right to sail ships flying its flag on the high seas.

<sup>3</sup>SatyaN.Nandan and Shabtai Rosenne, *United Nations Convention on the Law of the Sea 1982 Commentary, Volume II*, Martinus Nijhoff Publishers, 1993, p.165.

<sup>4</sup> SatyaN.Nandan and Shabtai Rosenne, *United Nations Convention on the Law of the Sea 1982 Commentary, Volume II*, Martinus Nijhoff Publishers, 1993, p.168.

<sup>5</sup>Satya N. Nandan and Shabtai Rosenne, *United Nations Convention on the Law of the Sea 1982 Commentary, Volume II*, Martinus Nijhoff Publishers, 1993, p.168



eventual convention expressly so provided. When signing the Convention, the States declared again that its provisions were not prejudicial to their right to take measures to regulate the innocent passage of warships through their territorial sea.

The title of Section III of *the Convention* is “Innocent passage through the territorial sea”, consists of three subsections: subsection A, “Rules applicable to all ships”, subsection B, “Rules applicable to merchant ships and government ships operated for commercial purposes” and subsection C is “Rules applicable to warships and other government ships operated for non-commercial purposes”. This is in line with the provisions of *the 1958 Convention on the Territorial Sea and the Contiguous Zone*.<sup>1</sup>

Article 17, “Right of innocent passage”, is under subsection A and provides that “Subject to this Convention, ships of all States, whether coastal or land-locked, enjoy the right of innocent passage through the territorial sea.” Subsection A, including Article 17, applies to all ships and shall be read together with Articles 18 (Meaning of passage) and 19 (Meaning of innocent passage).<sup>2</sup>

Although article 17 of the Convention makes it clear that the right of innocent passage applies to all States and their ships, the controversy lies in whether the consent of the coastal State should be required for the innocent passage of foreign warships. Most of the major western maritime Powers advocate that warships should enjoy the same right of innocent passage as merchant ships, while most of the developing countries that advocate the need to obtain the prior consent of the coastal State for the passage of warships through the territorial sea.<sup>3</sup>

The attitudes of the maritime powers also went through significant change. Take the Soviet Union as an example, it had taken a conservative position at the First Conference on the Law of the Sea. However, it supported the right of innocent passage of warships since the Third Conference on the Law of the Sea. Russia now allows innocent passage of foreign warships to sail through its territorial sea but prohibits the passage of more than three foreign warships and foreign government vessels from the same country at the same time. Foreign nuclear-powered ships, warships, other government ships, ships carrying nuclear energy, other dangerous and noxious substances or materials must have the requisite documents for passage through Russian territorial sea, comply with international conventions on special precautionary measures for such ships, navigate a specific course of the territorial sea and submit to a special arrangement for the zoning of the course.<sup>4</sup> In terms of State practice, many major maritime States such as the United States, the United Kingdom, France, Germany, Italy, the Netherlands and Russia advocate that warships should enjoy the same right of innocent passage as merchant ships, while about 40 developing countries insist that warships must have the consent of the coastal State to pass through its territorial sea.<sup>5</sup>

---

<sup>1</sup>Shao Jin: “Rules of General International Law concerning the innocent passage of foreign warships through the territorial sea”, China annual of international law (1989) Foreign Translation Publishing House.

<sup>2</sup>Satya N.Nanda and Shabtai Rosenne, United Nations Convention on the Law of the Sea 1982 Commentary, Volume II, Martinus Nijhoff Publishers, 1993, p.125

<sup>3</sup>J.Ashley Roach & Robert W. Smith, United States Responses to Excessive Maritime Claims, Brill Academic Pub, 2nd ed., 1996, pp.266-267.

<sup>4</sup>Federal Act on the Internal Maritime Waters, Territorial Sea and Contiguous Zone of the Russian Federation, 17 July 1998, at [http://www.un.org/Depts/los/LEGISLATIONANDTREATIES/PDFFILES/RUS\\_1998\\_Act\\_TS.pdf](http://www.un.org/Depts/los/LEGISLATIONANDTREATIES/PDFFILES/RUS_1998_Act_TS.pdf). Access: 11 November, 2019.

<sup>5</sup> For more: <http://policy.defence.gov/OUSDP-Offices/FON>.

## 2、 China's position on innocent passage of warships

Since the People's Republic of China resumed its lawful seat in the United Nations, the Chinese delegation has repeatedly stated its position on innocent passage in the territorial sea in its statements on the United Nations Seabed Committee and the Third United Nations Conference on the Law of the Sea. China's domestic legislation and practice are consistent with that.

### 2.1 Seabed Committee period

In its statement during the conference of the Seabed Committee, the Chinese delegation stated its position on innocent passage of warships. China holds that foreign merchant vessels may pass through the territorial sea with innocent passage, but warships should apply for prior approval, notification or permission. The Chinese delegation also explained its understanding towards the meaning of "innocent passage".

For innocent passage through a strait, the representatives of China pointed out in the group 2 of the conference of the Seabed Committee that straits within the territorial sea of States, whether or not regularly used for international navigation, should be administered by the littoral States. Foreign merchant ships may pass through with innocent passage, but should comply with the relevant laws and regulations of the coastal States, and that foreign warships must obtain prior authorization to pass through straits belonging to the coastal States. The Straits within the Territorial Sea.<sup>1</sup>

The provisions of *the Convention on the Territorial Sea and the Contiguous Zone*, adopted by the First United Nations Conference on the Law of the Sea, on innocent passage, the representatives of China, in his statement at the conference, pointed out that article 14 of *the Convention on the Territorial Sea and the Contiguous Zone* only provides that 'ships of all States' have the right of innocent passage through the territorial sea.

In 1973, at the second conference of the United Nations Seabed Committee, the Chinese delegation submitted a "working paper on the law of the sea in areas under national jurisdiction" (hereinafter referred to as "the working paper"), expressing the Chinese delegation's consistent position on the law of the sea. The "working paper" shows China's attitude towards innocent passage. It includes China's views on innocent passage. Firstly, it defines the term as "innocent passage". It means passage that does not impair the peace, security and good order of the coastal State. Secondly, foreign non-military ships can pass through the territorial sea without innocent. Thirdly, the passage of foreign military ships through the territorial sea shall be subject to prior notification to the competent authorities or prior authorization by the competent authorities. Fourthly, foreign ships and aircraft passing through other countries' territorial waters and the airspace over them shall abide by the necessary laws and regulations formulated and promulgated by the coastal State.<sup>2</sup>

### 2.2 The period of the Third United Nations Conference on the Law of the Sea

During the Third United Nations Conference on the Law of the Sea, the passage of warships through the territorial sea continued to be a point of contention. The claims of maritime Powers and developing countries were different: the former argued for the

---

<sup>1</sup>Department of International Law, Faculty of Law, Peking University: *A collection of law of the sea materials*, People's Publishing House, 1974, p. 33.

<sup>2</sup>Peking University, Faculty of Law, Teaching and Research Department of International Law: *A Collection of Materials on the Law of the Sea*, People's Publishing House, 1974 edition, p. 74.

exercise of the right of innocent passage by foreign warships within the territorial sea of the coastal State, while the latter demanded that foreign warships be required to notify the competent authorities of the coastal State in advance or to obtain permission from them before passing through its territorial sea. Although a text reflecting both propositions was included in the document entitled “*Main Trends*” presented in the Second Committee in 1974, the provisions on the subject in *the Informal Single Consultative Text* produced at the third part of the session in 1975 reflected only the position of the major maritime Powers and expressly provided that the rule of innocent passage applied to warships, which was opposed by more than 30 States.

The above-mentioned article was deleted from *the Revised Single Formal Negotiated Text* produced in the fourth part of the session in 1976, and the 1976 text has been reproduced in various subsequent negotiated texts.

Since the seventh part of the 1978 session, China and over 20 developing countries have made contributions to the discussion and formulation of the Convention by submitting joint proposals on many occasions, including proposals on the need to obtain prior authorization or notification for the passage of foreign warships through the territorial seas of coastal States and on the security of the territorial seas of coastal States.

First of all, **in terms of the nature of warships and ordinary commercial vessels**, innocent passage is only a convenient way provided by the coastal State and should be regulated by domestic law.

The text of *the Informal Composite Consultations* produced at the sixth session did not reflect the attitudes of the Chinese delegation and many other States on the passage of military ships through the territorial sea. So, on April 28, 1978, the Chinese delegation stated at the informal meeting of the Second Committee: “We all know that the nature of warships and ordinary commercial vessels are different. For both kind of ships, whether to grant foreign military ships the facilities for innocent passage in the territorial waters should be decided by the coastal State by its laws and regulations.”<sup>1</sup> “The way *the Informal Comprehensive Consultative Text* expresses, which makes no distinction between ordinary and military ships, is unacceptable to the Chinese delegation.” The Chinese text emphasizes the difference between the nature of warships and ordinary commercial vessels and considers the innocent passage of foreign warships in the territorial sea of a coastal State as a convenience provided by the State, which should be determined by the State under its laws and regulations.

During the ninth session of the Conference in 1980, China joined the informal proposal put forward by Argentina and others in solidarity with the legitimate demands of developing countries for the right of coastal States to establish necessary regulations for the passage of foreign warships through the territorial sea, “including the right to require prior consent and notification of passage through the territorial sea”. China’s attitude indicates that the passage of foreign warships through the territorial sea of a coastal State is subject to the domestic regulations of the coastal State, including prior of consent and notification to the coastal State.

**Secondly, the “security” of the territorial sea.** In 1982, the eleventh session of the Conference, 28 States, including China, submitted a joint proposal (C.2/Informal Meeting/58/Rev.1) and a formal amendment (A/CONF.62/L.117) in the Second Committee and the plenary, suggesting that coastal States should have the right to require the passage of foreign warships to abide by their national laws and regulations. The

---

<sup>1</sup> The collection of documents of the delegation of the People’s Republic of China to relevant United Nations meetings (1978.1- 6), People’s Publishing House 1978, pp. 131-132.

passage through the territorial sea should be preceded by the approval or notification of that State. The “security” of the coastal State should be included in the formulation of laws and regulations for innocent passage through the territorial sea.

Considering the sharp confrontation between the co-sponsors and the opposing States on this issue and to avoid a breakdown of the meeting, it was agreed that the two sides would not insist on a vote and that the President of the General Assembly would make a statement in plenary conference, that is “without prejudice to the right of the coastal State to take measures to ensure its security following Article 19 (Meaning of innocent passage through the territorial sea) and Article 25 (Right of protection of the coastal State) of the Convention. Lastly, the provisions of the Convention on innocent passage through the territorial sea are almost identical to those of *the 1958 Convention on the Territorial Sea and the Contiguous Zone*.

In its statement of March 31, 1982, the Chinese delegation stressed again that the regime for the passage of warships through the territorial sea “concerns the sovereignty and security of coastal States and is of great importance to many countries”.<sup>1</sup> Since the lack of clarity of the relevant provisions in the current draft convention and the potential of further differences in interpretation and implementation, China and the countries concerned jointly put forward a proposal to add a clause. By which, a coastal State, in accordance with its own laws and regulations, should require a foreign military vessel to obtain prior approval or notification of that state through its territorial waters.

**Lastly, this position on innocent passage was restated on the occasion of the signing of the Convention.** At the Conference at which the Convention was adopted on April 30, 1982, the Chinese delegation reiterated in its statement: “The provisions of this Convention relating to innocent passage in the territorial sea are without prejudice to the right of the coastal State to require, under its national laws and regulations, the prior approval or notification by the coastal State of the passage of foreign warships through the territorial sea.”<sup>2</sup>

On December 9, 1982, at the signing ceremony of the Convention on the final session of the Third United Nations Conference on the Law of the Sea, the Chinese delegation also stated in its statement: “We have repeatedly pointed out in the previous sessions that the provisions of the Convention on innocent passage through the territorial sea do not provide clear provisions on the regime for the passage of warships through the territorial sea, and some countries, including China, have proposed amendments to the Convention. At the April session of this year, in response to the proposed by the President of the conference, the co-sponsors did not insist that the amendment be put to the vote. However, the statement made by the President of the Conference at that time has made it clear that this does not affect the principled position of the co-sponsors calling for the safeguarding of their security.”<sup>3</sup>

In summary, China’s attitude was clear and never wavered during the Third United Nations Conference on the Law of the Sea. In terms of nature, warships are different from merchant ships, coastal states have the right to make necessary regulations on the passage of foreign warships through their territorial sea, and the passage of foreign warships through the territorial seas of coastal states requires prior approval for or prior notification

---

<sup>1</sup>State Oceanic Administration, Selected Laws and Regulations of Territorial Seas and Contiguous Zones, Law Press, 1985, Pp. 193-194.

<sup>2</sup> “The Chinese delegation to the United Nations” (1982.1-6), World Knowledge Press, 1983, p. 91.

<sup>3</sup> State Oceanic Administration, Selected Laws and Regulations of Territorial Seas and Contiguous Zones, Law Press, 1985, P195.

to that state.

The statement made by the President of the General Assembly at the ninth plenary meeting is explicit that coastal States have the right to take measures to ensure their **security** following the relevant provisions of the Convention.

### 3、 China’s domestic law and State practice on innocent passage

During the negotiation of the Convention, and after China’s signature and ratification of the Convention, Chinese government has insisted that the passage of foreign warships through its territorial sea requires China’s prior consent, which can be shown in the form of “permission”, “approval” or “notification”.

#### 3.1 Permission and approval

On September 4, 1958, the 100th meeting of the Standing Committee of the First National People’s Congress approved *the 1958 Declaration of the Government of the People’s Republic of China on China’s Territorial Sea* (hereinafter referred to as the Declaration on the Territorial Sea), which demands that the foreign warships that pass innocently through China’s territorial waters must first obtain permission from the Chinese government.<sup>1</sup>

Article 3 of the Declaration on the Territorial Sea clearly states, “no foreign vessels for military use and no foreign aircraft may enter China’s territorial sea and the air space above it without the permission of the Government of the Peoples Republic of China”. It is worth noting that the “permission” in the Declaration of Territorial Sea applies to all foreign aircraft and warships.

Innocent passage of foreign warships through China’s territorial seas in the relevant domestic laws of China is subject to the prior approval of the Chinese government. The first domestic law of China that deals with innocent passage is *the Maritime Traffic Safety Law of the People’s Republic of China* (hereinafter referred to as the “Maritime Traffic Safety Law”). According to the Article 11, Paragraph 2 of Maritime Traffic Safety Law approved on 2<sup>nd</sup> September, 1983: “Military vessels of foreign nationality may not enter the territorial sea of the People’s Republic of China without the approval of the Government of the People’s Republic of China.”<sup>2</sup>

On February 25, 1992, Article 6 (2) of the Law of the People’s Republic of China on the Territorial Sea and Contiguous Zone restates that, “The entry of a foreign military vessel into the territorial sea of the People’s Republic of China must be subject to the approval of the Government of the People’s Republic of China”.<sup>3</sup> On October 25, 1991, Yan Hongmo, then Director of the State Oceanic Administration, made the “*Explanation on the Law of the Peoples’ Republic of China on the Territorial Sea and Contiguous Zone (Draft)*” (hereinafter referred to as the “Explanation”) at the 22<sup>nd</sup> meeting of the Standing Committee of the Seventh National Peoples’ Congress, in the “Regime on the Passage of Foreign Ships through the Territorial Sea”, it was held that “Given the realities in China, the Draft adopts an authorization system for the passage of foreign warships through the

<sup>1</sup>Section 3 of the Government of the People’s Republic of China Declaration on Territorial Sea. Website of the Chinese People’s Congress: [http://www.npc.gov.cn/wxzl/gongbao/1958-09/04/content\\_1480851.htm](http://www.npc.gov.cn/wxzl/gongbao/1958-09/04/content_1480851.htm) (9 December,2019)

<sup>2</sup>Maritime Traffic Safety Law of the People’s Republic of China, Website of the Chinese People’s Congress: [www.npc.gov.cn/wxzl/gongbao/2000-12/06/content\\_4434.htm](http://www.npc.gov.cn/wxzl/gongbao/2000-12/06/content_4434.htm) (9 December,2019)

<sup>3</sup> Article 6 (2) of the Law of the People’s Republic of China on the Territorial Sea and Contiguous Zone, Website of the Chinese People’s Congress: [http://www.npc.gov.cn/wxzl/wxzl/2000-12/05/content\\_4562.htm](http://www.npc.gov.cn/wxzl/wxzl/2000-12/05/content_4562.htm) (9 December,2019)

territorial sea. Article 6 (2) of the Draft provides that the entry of foreign military vessels into the territorial sea of the People's Republic of China requires the approval of **the Government** of the People's Republic of China". The Draft also argues that "such a provision is consistent with China's 1958 'Declaration on the Territorial Sea' and the 1983 Law on Maritime Traffic Safety".

The author believes that prior permission and prior approval is the requirement for a prior express consent in both the Declaration on the Territorial Sea adopted with the approval of the Standing Committee of the National People's Congress and relevant Chinese domestic laws regarding the innocent passage of foreign warships through China's territorial sea. However, there is a certain difference between "permission" and "approval". It is inaccurate to say that the system of authorization for the passage of foreign warships through the territorial sea adopted in the draft law is consistent with the provisions of China's 1958 Declaration on the Territorial Sea.

As for the nature of the Explanation on the Draft Law, it should have a report submitted by the drafting department to the National People's Congress or the Standing Committee for consideration, including an introduction to and explanation of the background and process of drafting, the main contents of the draft law and the main system to be established. To some extent, such explanation may reflect the legislative intent, they are not legislative interpretations in themselves and should have no legal effect.

### 3.2 Approval and Notification

On 15 May 1996, the decision of the 19th meeting of the Eighth Standing Committee of the National People's Congress on the ratification of the convention states: "The People's Republic of China reaffirms that the provisions of the United Nations Convention on the Law of the Sea relating to innocent passage in the territorial sea shall not prejudice the right of a coastal state, in accordance with its laws and regulations, to require **the prior permission** or notification of that state for the passage of foreign warships through the territorial sea".<sup>1</sup>

This decision can be explained as follows: first, as a coastal state that has signed and ratified the Convention, China may enact relevant laws and regulations regarding innocent passage of its territorial sea. Second, these laws and regulations may include requirements that foreign warships must obtain prior permission or notification from the Chinese government for passage through China's territorial sea.

Given that the conjunction between "permission" and "notification" in the "decision" is "or", which means it can be chosen. Moreover, there is no provision in the Law on the Territorial Sea and Contiguous Zone and the Maritime Traffic Safety Law, stipulating that foreign warships must notify the Chinese government in advance of their passage through China's territorial sea.

### 3.3 China's Practice on Innocent Passage

China's state practice regarding innocent passage through the territorial sea is mainly embodied in its protest against and criticism of the intrusion of foreign warships into its territorial sea.

After the 1958 Territorial Sea Declaration was issued, the United States warships and aircraft continued to violate China's territorial waters and airspace, to which China lodged

---

<sup>1</sup> Decision of the Standing Committee of the National People's Congress on the ratification of the United Nations Convention on the Law of the Sea, No. 4, of 15 May 1996 Pass. Website: [www.npc.gov.cn/wxzl/gongbao/2000-12/16/content\\_5003571.htm](http://www.npc.gov.cn/wxzl/gongbao/2000-12/16/content_5003571.htm) (9 December,2019)

repeated protests. On September 7, 1958, the Ministry of Foreign Affairs issued a serious warning to the United States warships for encroaching on China's territorial sea, and on May 25, 1960, United States warships intruded into China's Fujian coast, and on May 27, the Chinese Government issued its 100th warning to the United States Government. On April 26, 1962, United States warships twice intruded into the waters near Shuixing Island in China's Xisha Islands, and the Chinese Government issued the 200th serious warning to the United States. From September 7, 1958, to July 1, 1964, 315 U.S. warships violated China's territorial sea 201 times and 405 U.S. aircraft violated China's airspace 233 times, and on June 23, 1969, China issued the 469th serious warning about the violation of China's territorial sea and airspace by whole aircraft and whole ships.<sup>1</sup>

Over the past few years, the United States warships have repeatedly entered the territorial sea of China's Xisha (Paracel) Islands without permission or sailed within 12 nautical miles of the Gaven Reef and Johnson South Reef in the Nansha (Spratly) Islands. China's island-defending forces and warships and aircraft have taken action immediately, identifying and verifying the United States warships and warning them off. China's Ministry of Defence expressed firm opposition to the actions of the United States warships and stressed that *the Law on the Territorial Sea and the Contiguous Zone* stipulates that foreign warships must obtain prior approval to enter China's territorial sea.

American's warships have repeatedly sailed into and through the waters of the Nansha Islands, entered and crossed the territorial sea of the Xisha Islands,<sup>2</sup> and even stopped within 12 nautical miles of the reefs to conduct life-saving training.<sup>3</sup> Such actions as deliberately stopping in the territorial sea and conducting life-saving training, which is "not directly related to the passage". These are clearly "non-innocent passage".

The U.S. warship trespassed into the territorial sea of South China Sea islands without the permission of the Chinese government, which is a demonstration that America has always insisted on the right of innocent passage through waters of other States without prior notice or approval.<sup>4</sup> This deliberate action of non-innocent passage challenge China's claim to straight baselines around the Xisha Island.

The protests and refutations by China's Ministry of Foreign Affairs and Ministry of National Defense are aimed at the unauthorized entry of the US warship into Chinese territorial sea in violation of Chinese law. They are not denying the right of innocent passage of the US warship.

#### 4、The View of the Chinese academia

On the right of innocent passage of warships, there are two main views in Chinese academic community: the affirmative and the negative.

---

<sup>1</sup> Reference: "China issued the 469th serious warning" in the face of the US invasion in 1969.

Website: <http://www.xixik.com/content/e2f11b5356193849> (26 September, 2019)

<sup>2</sup> Statement by Yang Yujun, spokesperson for the Ministry of National Defense, on the unauthorized entry of a U.S. warship into Paracel Islands Territorial Waters". Website:

[http://www.mod.gov.cn/affair/2016-01/30/content\\_4638339.htm](http://www.mod.gov.cn/affair/2016-01/30/content_4638339.htm) (16 December, 2019)

<sup>3</sup> "Regular press conference held on 6 May 2019 by the spokesperson of the Ministry of Foreign Affairs, Geng Shuang". Website:

[https://www.fmprc.gov.cn/web/wjdt\\_674879/fyrbt\\_674889/t1661103.shtml](https://www.fmprc.gov.cn/web/wjdt_674879/fyrbt_674889/t1661103.shtml) (16 December, 2019)

<sup>4</sup> "Defense Ministry spokesman Wu Qian's question and answer on US vessel unauthorized entry into Paracel Islands territorial waters", Chinese military website: within 12 nautical miles of the Xisha Islands. Link: [http://www.81.cn/xwfy/2018-05/27/content\\_8044121.htm](http://www.81.cn/xwfy/2018-05/27/content_8044121.htm). And "Two US warships have intruded within 12 nautical miles of Paracel Islands, executive aircraft 'exercise in motion'."

Link: <https://new.qq.com/omn/20180527/20180527A1GT2Z00> (18 December, 2019)

#### 4.1 Affirmation

Supporters argue that warships enjoy the same right of innocent passage through the territorial sea as merchant ships, no need for prior approval, permission or notification by the coastal State. The foundation is that article 17 of the Convention, “right of innocent passage”, provides that “Subject to this Convention, ships of all States, whether coastal or land-locked, enjoy the right of innocent passage through the territorial sea”. This article is located under subsection A, “Rules applicable to all ships”. The Convention does not distinguish between merchant ships or warships or provide that warships are not a kind of ship. Hence, ships of any States enjoy the right of innocent passage through the territorial sea.

They also mentioned that subsection A is the first of the three subsections of section III on “innocent passage through the territorial sea”, which is a general provision and a specific provision applicable to subsections B and C. From all the three subsections that warships should be considered to enjoy the same right of innocent passage as ordinary merchant ships.<sup>1</sup> Subsection A “includes rules requiring submarines and other submersibles to navigate on the surface of the water, granting a right of innocent passage to submarines”. At the adoption of the Convention, submarines were only warships, and the granting of the right of innocent passage to submarines indicates that the right of innocent passage was also granted to warships”.<sup>2</sup> Furthermore, Article 24 of section A, “duties of the coastal State”, provides that the coastal State shall not hamper the innocent passage of foreign ships through the territorial sea except under this Convention. In particular, in the application of this Convention or of any laws or regulations adopted in conformity with this Convention.

Positivists cite *the 1958 Convention on the Territorial Sea and the Contiguous Zone* to prove that the Convention provides for the right of innocent passage for all ships, including warships.<sup>3</sup> “The 1958 territorial sea convention provides that ships of all states, whether for military or civilian use, shall have the right of ‘innocent passage’ through the territorial sea. Although the present convention imposes some further restrictions on the passage of warships, it basically follows the provisions of the 1958 territorial sea convention.” “The basic provisions of the two conventions on innocent passage through the territorial sea are the same or almost the same.”<sup>4</sup> Thus, foreign warships enjoy the right of innocent passage in the territorial sea.

#### 4.2 Denial

There are those who are of the view that warships do not enjoy the right of innocent passage. “The right of innocent passage applies only to merchant ships, and warships do not enjoy this freedom.” “To affirm the right of innocent passage for merchant ships while denying the right of passage for warships represents the correct theory and is in line with

---

<sup>1</sup> Chen Zhenguo, On the Right of Innocent Passage of Territorial Sea, Politics and Law, no. 1,1985, Pp. 31-34.

<sup>2</sup> Li Hongyun, On the Right of Innocent Passage of Foreign Warships In Territorial Waters, Chinese and Foreign jurisprudence, no. 4,1988, Pp. 88-92

<sup>3</sup>Shen Weiliang, Xu Guangjian. The Third United Nations Convention on the Law of the Sea and United Nations Convention on the Law of the Sea, China Annual of International Law (1983), page 410-411. China National Translation and Publishing Corporation.

<sup>4</sup>Shao Jin, General Rules of International Law concerning the innocent passage of foreign warships through the territorial sea, Chinese Annual of International Law (1989) , no. 12 China Foreign Translation Publishing House.



international practice.”<sup>1</sup> “Following the provisions of the Convention on the Territorial Sea and the Contiguous Zone adopted by the Geneva Conference in 1958, the right of innocent passage applies to the ships of all countries, without distinction between warships and merchant ships. This certainly cannot be defined as general international practice and is not a rule acceptable to all States.”<sup>2</sup>

Interestingly, this argument that the 1958 Convention on the Territorial Sea and Contiguous Zone gives the right of innocent passage without distinction between warships or merchant ships, which is used to prove that the Convention also makes the same provision but ignores the author’s denial that this view represents general international practice, and then argues that the author’s endorsement of the right of innocent passage of warships is a misreading of the author’s argument.

Opponents also argue that the passage of warships through the territorial sea and the passage of ordinary merchant ships are not equated at all. The content: “regime for the passage of military vessels through the territorial sea is inconsistent with the generally accepted theory and practice of international law.”<sup>3</sup>

China’s current laws and regulations, decisions of National People’s Congress and academic opinions all emphasize the need for prior approval for or prior notice to warships to pass through territorial sea. But there was no clear answer whether China recognized the right of innocent passage of warships or not.

From my point, the premise of “approval” is to agree that the other party has some kind of right, but the exercise of that right requires application and approval. Although China’s legislation does not stipulate, legal logic and national practice recognize the right of innocent passage of foreign warships in China’s territorial sea, which is a kind of conditional right of innocent passage. Namely, foreign warships must apply to the Chinese government and obtain its approval before exercising the right of innocent passage in China’s territorial sea. This also means that without the approval of the Chinese government, they cannot enter and sail into the Chinese territorial sea. As Mr. Wang Tiewa stated, “Under generally accepted principles of international law, a coastal state may require prior permission or notification as a condition for the passage of a foreign warship through its territorial sea.”<sup>4</sup>

Warships making innocent passage in the territorial sea of a coastal state shall abide by the laws and regulations of the coastal State concerning passage through its territorial sea. If any warship violates the laws and regulations of the coastal state with respect to its territorial sea and disregards any request from the coastal state to comply with the laws and regulations, the coastal State may require the warship to leave its territorial sea immediately. The flag State is internationally responsible for any loss or damage suffered by the coastal State as a result of non-compliance by foreign warships with the laws and regulations of the coastal state relating to its territorial sea or with the provisions of the Convention or other rules of international law.

## 5、 Conclusion

In the Article 29 of the Convention, the definition of warships is given as follows: “For the purposes of this Convention, “warship” means a ship belonging to the armed

---

<sup>1</sup>Chou Gengsheng, international law (volume I) , Commercial Press, 1976, p. 370.

<sup>2</sup>Chou Gengsheng, international law (volume I) , Commercial Press, 1976, p. 370.

<sup>3</sup> Liu Nanlai, Zhou Ziya. International Law of the Sea. Ocean Press, 81(1986) .

<sup>4</sup>Deng Zhenglai, *Anthology of Wang Tiewa*, China University of Political Science and Law, 2003, p. 336.

forces of a State bearing the external marks distinguishing such ships of its nationality, under the command of an officer duly commissioned by the government of the State and whose name appears in the appropriate service list or its equivalent, and manned by a crew which is under regular armed forces discipline". It can be said that warships are a type of ship.

From the Seabed Committee to the Third United Nations Conference on the Law of the Sea, discussions on the right of innocent passage of warships have revolved around whether prior consent (e.g., permission, approval) or prior notification from the coastal State is required. It's not about whether warships have a right of innocent passage or not. The maritime powers insist that the passage of warships do not require the consent of or prior notification to the coastal State. While developing countries, mainly from the perspective of national security, require prior consent or notification to the coastal State. It is clear that such a claim does not deny the right of innocent passage of a foreign warship through the territorial sea of a coastal state, but attaches conditions to such a right, namely, prior permission, authorization or prior notification to the coastal state. In particular, the requirement of approval and prior notification cannot be based on the denial of the right of innocent passage to foreign warships. In other words, if the right of innocent passage of a foreign warship is not recognized, there is no question of its authorization, and it is difficult for a foreign warship to obtain such a right based on a single notice.

here are three points on the right of innocent passage of warships: the innocent passage system, the prior notification system and the approval system. China operates a system of approval.<sup>1</sup> However, the approval system was neither discussed as a regime governing the innocent passage of warships during the commission on the seabed nor during the third United Nations Convention on the Law of the Sea. Proposals were made and discussed about approval, permission or notification as conditions for the exercise of the right of innocent passage by foreign warships.

In terms of China's legislation and practice, from the 1958 Declaration on the Territorial Sea to the 1983 Maritime Traffic Safety Law, and the 1992 Law on the Territorial Sea and Contiguous Zone, China's attitude on innocent passage of warships in the territorial sea has always required prior and explicit consent. China recognizes and respects the right of innocent passage of warships in the territorial sea of coastal States under international law, including that in the Convention. However, foreign States have not been able to exercise the right of innocent passage in the territorial sea. The passage of warships through China's territorial sea requires the prior and explicit consent of the Chinese Government, which is initially expressed as "permission" and, in the case of the Maritime Traffic Safety Law and the Territorial Sea and Contiguous Zone Law, as "approval", which is a conditional right of innocent passage.

This "approval" can be interpreted to mean the following: first, China recognizes the right of innocent passage of foreign warships in China's territorial sea. Second, foreign warships intending to pass through China's territorial sea shall submit applications for innocent passage through China's territorial sea to the relevant departments of the Chinese Government. Third, the relevant departments shall examine and approve such applications. Fourth, the approved foreign warships that have obtained approval submit applications for innocent passage shall pass through China's territorial waters following the conditions or requirements of the approval. If it is not approved, the warships shall not pass.

The 1958 Declaration on the Territorial Sea, along with the relevant domestic laws (*the Maritime Traffic Safety Law, Law on the Territorial Sea and Contiguous Zone*) and

---

<sup>1</sup>Duan Jielong. *Chinese Practices and Cases in international Law*. Law Press, 111(2011) .

the decision of the National People's Congress to ratify the Convention, all stressed that the passage of foreign warships through China's territorial sea requires the prior approval of the Chinese government. In other words, only the Chinese government (or the relevant departments authorized by the Chinese government) has the right to receive and approve applications for innocent passage of foreign warships

Translators: Deng Chi Fei,  
Regina Law

Editor (English): Arpita Goswami Sachdeva



# 论《海警法（草案）》背景下海警机构的行政属性

阎铁毅\* 马琨\*\*

**摘要：**自党的十八大以来，我国成立了统一的海警机构并进行了一系列改革，改革中自然出现各种疑问，最重要的就是认为军队不应当成为行政主体的问题。此疑问也引起一些别有用心国家的炒作。本文试着从理论与实践层面、国内与国外角度，并结合本次《海警法（草案）》对这一疑问进行回应。

**关键词：**海警机构 改革 行政属性

## 一、引言

从法律的角度来说，自海警机构划入武警序列，直属中央军委，与国务院系统分离后，很多人一直讨论海警机构是否存在行政属性？

无论海警机构是属于军事系统，例如美国海岸警卫队是美国五大武装力量之一，还是属于行政系统，例如韩国的海洋警察厅、日本的海上保安厅，他们的行政属性都是十分确定的。这一点可以从各国关于海警机构的立法、程序规定、救济途径中得出答案。

为何一定要确定海警机构的行政属性？有以下几点考虑。

第一，确定海警机构的行政属性能够方便设定其具有的权力内容和执法程序。在行政法的立法中，有许多共性的、通用的内容适用于海警机构。这样的一种适用，既降低立法成本，也方便一般民众了解海警机构，以便更好地执法。

第二，确定海警机构的行政属性可以更好地进行权力监督。如若无法确定海警机构的行政属性，就无法将行政法理论中权力监督的内容予以适用。一般来说，为

---

本文系国家社会科学基金重大项目“大数据、人工智能背景下的公安法治建设研究”(19ZDA165)；国家社会科学基金重大项目“中国海权发展模式及海洋法制完善研究”(17ZDA145)；国家社科基金“新时代海洋强国建设”重大研究专项“海洋命运共同体视野下的中国海洋权益维护研究”(19VHQ009)的阶段性研究成果。

\* 阎铁毅（1970—），男，汉族，籍贯山东荣成，大连海事大学法学院教授、博导，所在二级学科：宪法学与行政法学。

\*\* 马琨（1996—）男，汉族，籍贯福建龙岩，大连海事大学法学院2020级法律硕士研究生。

©THE AUTHOR AND MARINE LAW AND POLICY

了国家安全，不方便运用行政法监督军事部门。

第三，确定海警机构的行政属性可以方便当事人更好地进行救济。当事人主要通过行政复议、行政诉讼寻求权利救济。

第四，确定海警机构的行政属性可以更好地促进信息公开，方便社会公众守法、用法，并促进各种社会主体对海警机构进行监督。

## 二、我国海警机构的历史沿革

海警是主权国家设立的，为维护国家海洋权益，维护海上治安秩序，预防、惩治、打击海上违法犯罪、军事威胁，保护海洋生态环境，保证海洋资源的开发利用，进行海上安全保卫、宣示主权，开展国际合作的执法力量<sup>1</sup>。

在2013年之前，我国并不存在统一的海警机构，相关的职能大约由五个不同的机构行使。这其中包括了1982年成立的中国海监、1998年成立的中国渔政、1998年成立的中国海事、中国海关缉私警察和公安海警部队等五个机构，共同行使海警机构的职权，这一阶段也常常被学界称之为“五龙治海”。在近海案件密集、专业突出的条件下，分工管辖效能明显。但在远海案件较少、专业综合的条件下，分工管辖成本较大、效能较低。

因此，在党的十八大“海洋强国”战略作出后，我国对于海上执法体制进行了重大改革。

第一，2013年3月14日，第十二届全国人民代表大会第一次会议审议通过了《国务院机构改革和职能转变方案》，决定重新组建国家海洋局：“将现国家海洋局及其中国海监、公安部边防海警、农业部中国渔政、海关总署海上缉私警察的队伍和职责整合，重新组建国家海洋局，由国土资源部管理。主要职责是，拟订海洋发展规划，实施海上维权执法，监督管理海域使用、海洋环境保护等。国家海洋局以中国海警局名义开展海上维权执法，接受公安部业务指导。”这是新中国成立以来，首次设立统一的海警机构，为后来的改革打下了基础。

第二，根据2018年3月公布的《深化党和国家机构改革方案》，按照先移交、后整编的方式，将国家海洋局（中国海警局）领导管理的海警队伍及相关职能全部划归武警部队。

第三，是在2018年6月22日，十三届全国人大常委会第三次会议通过《全国人民代表大会常务委员会关于中国海警局行使海上维权执法职权的决定》称，海警队伍整体划归中国人民武装警察部队领导指挥，调整组建中国人民武装警察部队海警总队，称中国海警局，中国海警局统一履行海上维权执法职责。该决定自2018年7月1日起施行。中国海警局“行使法律规定的公安机关相应执法职权”和“行使法律规定的有关行政机关相应执法职权”。同时规定“条件成熟时，有关方面应当及时提出制定、修改有关法律的议案，依照法定程序提请审议”。为了海警机构在行使相关职能上的便利，还修改了《刑事诉讼法》，明确规定海警机构办理刑事案

---

<sup>1</sup> 汪炳均. 完善我国海警执法制度的路径探析[D].中国人民公安大学,2019.

件的资格。

### 三、《海警法（草案）》中行政属性的明晰

中国和大陆法系国家在学理上，将能够行使行政职权的组织统称行政主体。即行政主体指的是依法拥有行政职权，能够以自己名义独立进行行政管理，并对行使职权的行为产生的效果承担法律责任的组织<sup>1</sup>。具体而言，在中国，行政主体主要指的是行政机关和法律、法规授权的组织。行政机关根据组织法设立，而法律、法规授权的组织由行政授权设立或获得相应权力，例如根据《律师法》设立并管理各地律师事务的各级律师协会等等。

具体而言，行政授权是由法律、法规明确，通过法定方式将行政职权的部分或全部，授予某个组织的法律行为<sup>2</sup>。获得授权后，被授权者以自己的名义行使行政职权，实施行政管理，并对外独立承担相应的法律责任<sup>3</sup>。在授权的主体上，分为全国人大及其常委会授权和其他机关授权，全国人大及其常委会的授权被认为是行政权力的分配，具有根本性。而其他机关的授权则是一种二次分配<sup>4</sup>。

第一，当下划归武警部队我国海警机构，能否成为被法律、法规授权的对象呢？答案是肯定的。对于被授权组织，虽然当前理论界主流尚未将目光放在军事力量这一特殊组织上，但是从世界范围来看，将其列入是各国通行做法。例如法国、德国、日本等大陆法系国家的公物警察理论及实践，美国海岸警备队作为军队的行政执法实践，以及其他很多国家直接使用海军的行政执法实践。

而在第十三届全国人大常委会第二十二次会议对《海警法（草案）》进行了审议，2020年11月4日在中国人大网公布，向社会征集意见。在《海警法（草案）》中，开宗明义的在第二条就明确宣示我国海警机构的军事属性和行政属性<sup>5</sup>。这一条文在未来成为正式法律规定，可以说是在制定法的角度，通过法律授权的方式，授权确定了我国海警机构的行政属性。

第二，《海警法（草案）》较2018年《决定》在授权事项上更为明确，这使得我国海警机构的行政权力边界更为清楚，换言之，也进一步加强其行政属性。2018年《决定》只在几项事项上概括授予了权力<sup>6</sup>，而《海警法（草案）》除了第五条同样规定了上述概括的权力，在第十一条更是详细规定了具体的权力边界，例如规定“（一）负责在我国管辖海域开展巡航、警戒，值守重点岛礁，管护海上划界线，

<sup>1</sup> 胡建淼.行政法学概要[M].杭州：浙江工商大学出版社，2012:42.

<sup>2</sup> 罗豪才.行政法学[M].北京：北京大学出版社，1996:76.

<sup>3</sup> 胡建淼.行政法学[M].上海：复旦大学出版社，2003:78-79.

<sup>4</sup> 朱学磊.“法律、法规授权的组织”之身份困境及其破解——以行政诉讼为展开视角[J].江汉学术，2015,34(06):5-11.

<sup>5</sup> 2020年《海警法（草案）》第二条 海警机构是重要的海上武装力量和国家行政执法力量。

<sup>6</sup> 2018年《全国人民代表大会常务委员会关于中国海警局行使海上维权执法职权的决定》第一条 中国海警局履行海上维权执法职责，包括执行打击海上违法犯罪活动、维护海上治安和安全保卫、海洋资源开发利用、海洋生态环境保护、海洋渔业管理、海上缉私等方面的执法任务，以及协调指导地方海上执法工作。

预防、制止、排除危害国家主权、安全和海洋权益的行为；（二）负责海上重要目标和重大活动的安全保卫，采取必要措施保护重点岛礁以及专属经济区和大陆架的人工岛屿、设施和结构安全……”等等。

第三，《海警法（草案）》就行政执法程序做出了一系列特殊规定，并留下兜底设计——没有规定时适用一般行政法<sup>1</sup>，这一规定同样是对海警机构行政属性的进一步确定。

第四，《海警法（草案）》规定了行政相对人对于海警机构的处罚不服时，可以提起复议和诉讼<sup>2</sup>。是否能够救济同样是判断行政属性的一大标准，自2018年改革以来，因为某些人缺乏调研的原因，对于受到海警机构处理时能否救济、如何救济的问题一直不了解，而草案中的明确规定，使得这些疑问烟消云散。

总之，《海警法（草案）》对于我国海警机构的行政属性做出了明确的规定，但是应该清醒地认识到，当前法律尚未正式落地，只有等到其正式通过并发布正式文本，才能进一步确认。

#### 四、《海警法（草案）》中尚未明晰的点

《海警法（草案）》中有一些规定具有一定创造性，但是仍然不够明晰，需要进一步讨论其适用方式。

第一，是第十七条<sup>3</sup>、第十八条<sup>4</sup>、第十九条<sup>5</sup>三个关于执法权适用的规定，条文上大体没有问题，但是在适用对象上皆限定为外国的组织、个人等主体，这就涉及到一个问题，当行政相对人为我国的组织和个人时，能否适用上述条款来进行规制？一方面可以认为既然外国主体都适用，本国主体更是当然的适用；但是另一方面也可以认为这是对于外国主体的特殊规定，本国主体不应该适用。不管怎么样，在未来进一步审议草案和实践执法时，应当注意到这个问题。

第二，是第二十五条<sup>6</sup>，本条规定了海警机构在毗连区行使相应的职权，但是

---

<sup>1</sup> 2020年《海警法（草案）》第三十三条 海警机构开展海上行政执法的程序，本法未作规定的，适用《中华人民共和国行政处罚法》、《中华人民共和国行政强制法》、《中华人民共和国治安管理处罚法》等有关法律的规定。

<sup>2</sup> 2020年《海警法（草案）》第七十二条 个人和组织对海警机构作出的行政行为不服的，有权依照《中华人民共和国行政复议法》的规定向上一级海警机构申请行政复议；或者依照《中华人民共和国行政诉讼法》的规定向有管辖权的人民法院提起行政诉讼。

<sup>3</sup> 2020年《海警法（草案）》第十七条 未经我国主管机关批准，外国组织和个人在我国管辖海域和岛礁建造建筑物、构筑物，以及布设各类固定或者浮动装置，海警机构有权责令其停止违法行为或者限期整改；对拒不停止违法行为或者拒不限期整改的，必要时海警机构可以依法强制拆除。

<sup>4</sup> 2020年《海警法（草案）》第十八条 对外国军用船舶和用于非商业目的的外国政府船舶在我国管辖海域违反我国法律、法规的行为，海警机构有权采取必要的警戒和管制措施予以制止，责令其立即离开相关海域；对拒不离开并造成严重危害或者威胁的，海警机构有权采取强制驱离、强制拖离等措施。

<sup>5</sup> 2020年《海警法（草案）》第十九条 国家主权、主权权利和管辖权在海上正在受到外国组织、个人的不法侵害或者面临不法侵害的紧迫危险时，海警机构有权依据本法和其他相关法律、法规，采取包括使用武器在内的一切必要措施当场制止侵害、排除危险。

<sup>6</sup> 2020年《海警法（草案）》第二十五条 为预防和惩处在我国陆地领土、内水或者领海内违反



在专属经济区、大陆架是否也能够行使相应的职权呢？在公海我国管辖的深海底矿区海域是否也能够行使相应的职权呢？目前没有规定。这也需要在未来进一步明晰。

---

有关安全、海关、财政、卫生或者入境出境管理法律、法规的行为,海警机构有权在毗连区行使管制权,依法采取行政强制措施或者法律、法规规定的其他措施。

# The Administrative Attributes of Coast Guard Agencies in the Context of “*The Coast Guard Law (Draft)*”

Yan Tieyi\* Ma Kun\*\*

**Abstract:** Since the 18th CPC National Congress, China has established a unified coast guard agency and carried out a series of reforms, which have naturally raised various questions. The most important of these questions is whether or not the army should become an administrative subject. This question has also drawn sensationalized reactions from some countries with ulterior motives. This paper attempts to respond to this issue at the theoretical and practical levels, as well as from domestic and foreign perspectives, in the context of “*The Coast Guard Law (Draft)*”.

**Key words:** coast guard agency reform administrative attributes

## I. Introduction

Many people have been discussing whether, from a legal point of view, administrative attributes have been assigned to the China Coast Guard since it was transferred to the armed police authorities, which is directly affiliated with the Central Military Commission and separate from the State Council.

Whether a coast guard agency is part of a military system, such as the U.S. Coast Guard, which is among its five largest armed forces, or part of an administrative system, such as the Korea Marine Police Agency or the Japan Coast Guard, their administrative attributes are clearly established and confirmed by legislation and procedural regulations.

---

This article is the staged result of the periodical study of the following key research projects: Key research project “A Study on the Legal Construction of Public Security under the Background of Big Data and Artificial Intelligence” supported by National Social Science Foundation of China (19ZDA165); Key research project “Research on the Development Model of China's Maritime Rights and the Improvement of Maritime Legal System” supported by National Social Science Foundation of China (17ZDA145); Key research special project “Research on the Protection of China's Maritime Rights and Interests Following the Vision of a Community with a Shared Future for Oceans” of the project “Building an Ocean Power in the New Era” supported by National Social Science Foundation of China (19VHQ009).

\* Yan Tieyi (1970- ) Professor of Law; supervisor of doctoral candidate, Dalian Maritime University. subdiscipline: Constitutional and Administrative Law.

\*\* Ma Kun (1996- ) Masters student in Law, Dalian Maritime University.

©THE AUTHOR AND MARINE LAW AND POLICY

Why is it necessary to determine the administrative attributes of coast guard agencies? There are several considerations:

First, to help establish the extent of the agency's power, and to clarify its law enforcement procedures. In the existing legislation of administrative law, there is a lot of common, general content that can be applied to maritime police agencies. Such an application would both reduce the cost of legislation and make it easier for the general public to be familiar with maritime police agencies and their policies, thus increasing the likelihood of compliance.

Second, to more effectively supervise power. If the administrative attributes of a maritime police agency cannot be determined, then the content in the administrative law theory that relates to power supervision cannot be applied.

Third, to help provide remedies to the interested parties more efficiently. The parties can mainly seek rights relief through administrative reconsideration and administrative litigation.

Fourth, to better promote information disclosure. It will be more convenient for the public to abide by and use laws, which will encourage various social bodies to supervise maritime police agencies.

## **II. The Historical Evolution of China's Coast Guard Agencies**

Maritime police agencies are established by sovereign countries in order to safeguard their maritime rights and interests, which they do by serving as law enforcement agencies in various ways: by maintaining maritime public order; by preventing, punishing, and cracking down on maritime crimes and military threats; by protecting the marine ecological environment; by ensuring the development and utilization of marine resources; by conducting maritime security protection; by declaring sovereignty; and by engaging in international cooperation<sup>1</sup>.

Prior to 2013, there was not a unified coastguard agency in China, and related functions were performed by about five different agencies: China Maritime Supervision, established in 1982; China Fisheries Administration, established in 1998; China Maritime Affairs, China Customs Anti-Smuggling Police, and the Public Security Coast Guard, established in 1998. These five agencies jointly exercise the functions and powers of maritime police agencies. In academic circles, this stage is often referred to as "the five dragons governing the sea". In circumstances when caseloads are high and agencies can make use of their primary specialties, the division of jurisdiction is obviously effective; however, when there are fewer cases and specialties are integrated, the division of jurisdiction becomes costlier and less effective.

Therefore, since the 18th National Congress of the Communist Party of China created the strategy of "marine power", China has carried out significant reform to its maritime law enforcement system.

First, on March 14, 2013, at the first meeting of the 12th National People's Congress, the plan for the structural reform and functional transformation of the State Council was deliberated and adopted to reconstitute the State Oceanic Administration. According to the plan, "the State Oceanic Administration will be re-established and administered by the Ministry of Land and Resources by integrating the teams and responsibilities of the current SOA with those of the China Maritime Surveillance, the Border and Coast Police of the

---

<sup>1</sup> Wang Bingjun, Analysis on the Ways to Improve the Law Enforcement System of China Coast Guard [D]. People's Public Security University of China, 2019.

Ministry of Public Security, the Bureau of Fisheries of the Ministry of Agriculture, as well as the Maritime Anti-smuggling Police of the General Administration of Customs. Its main duties are to draw up marine development plans, enforce laws to safeguard maritime rights, supervise and manage the use of sea areas, and protect the marine environment. The SOA carries out maritime rights protection and law enforcement in the name of the China Coast Guard, and it receives operational guidance from the Ministry of Public Security.” For the first time since its founding, the People's Republic of China set up a unified coast guard organization, which laid the foundation for the subsequent reform.

Second, in accordance with the Plan for Deepening the Reform of Party and State Institutions, which was released in March 2018, all the coast guard teams and related functions under the leadership and management of the State Oceanic Administration (China Coast Guard) shall be assigned to the People’s Armed Police.

Third, on June 22, 2018, the Decision of the Standing Committee of the National People's Congress on the Exercise of the Power of Maritime Rights Protection and Law Enforcement by The China Sea Police was adopted at the third session of the Standing Committee of the 13th National People's Congress and would take effect from 1 July 2018. According to the decision, the marine police force was, as a whole, placed under the leadership and command of the People’s Armed Police and formed into China Coast Guard, which shall uniformly perform the duties of law enforcement for the protection of maritime rights. China Coast Guard shall “exercise such powers as are prescribed by law for the enforcement of the Public Security Bureau” and “exercise such powers as are prescribed by law for the enforcement of the relevant executive branch”. China Coast Guard would “exercise the corresponding law enforcement powers of the public security organs as prescribed by law” and “exercise the corresponding law enforcement powers of relevant administrative organs as prescribed by law”. At the same time, “when conditions are ripe, the parties concerned shall promptly put forward proposals to enact or amend relevant laws and submit them for deliberation in accordance with legal procedures”. In order to facilitate the coast guard organizations in exercising relevant functions, the Criminal Procedure Law has also been amended to clearly stipulate the qualifications of coast guard organizations to handle criminal cases.

### **III. The Clarity of the Administrative Attributes in *The Coast Guard Law (Draft)***

In theory, organizations capable of exercising administrative functions and powers are collectively referred to as administrative subjects in China and in civil law countries<sup>1</sup>. That is, an administrative subject refers to an organization that has administrative power according to law, that can independently conduct administrative management in its own name, and that bears legal responsibility for the effect of the act of exercising its power. To be specific, in China, administrative subject mainly refers to administrative organs and organizations authorized by laws and regulations. Administrative organs are established in accordance with *the Organic Law*, and organizations authorized by laws and regulations are established or granted corresponding powers by administrative authorization. For example, bar associations at all levels of local law firms are established and managed in accordance with *the Lawyers Law*.

Specifically, administrative authorization is a legal act that explicitly grants part or all of the administrative powers to an organization through statutory means, by laws or

---

1 Hu Jianmiao, (2002). *The Essentials of Administrative Law* [M]. Hangzhou: Zhejiang Gongshang University Press, 42.

regulations.<sup>1</sup> After being authorized, the authorized shall, in its own name, exercise administrative functions and powers, carry out administrative management, and bear the corresponding legal responsibilities independently.<sup>2</sup> The subject of authorization is divided into authorization by the NPC and its Standing Committee, as well as authorization by other organs, among which the former is considered the fundamental distributor of administrative power, while the authorization of other organs is considered secondary distribution.<sup>3</sup>

First, can China Coast Guard be authorized through laws and regulations to be included in the armed police force? The answer is that it can. For authorized organizations, although they have not been regarded by mainstream theorists as a special organization of military force, it is common practice for all countries to count them among the world's military forces. This can also be proved by the looking at the theory and practice of public property police in civil law countries, such as France, Germany, and Japan, as well as by the administrative law enforcement practice of the United States Coast Guard as a military force, and also by the administrative law enforcement practice of many other countries that use their navy directly.

*The Coast Guard Law (Draft)* (hereinafter the Draft) was reviewed at the 22nd Session of the Standing Committee of the 13th National People's Congress (NPC). On November 4, 2020, the Draft was published on the NPC website to solicit public comments. In the Draft, Article 2 declared the military and administrative attributes of China's marine police agencies.<sup>4</sup> This article will become a formal law in the future. From the perspective of lawmaking, and through legal authorization, this article can be considered an authorization to determine the administrative attributes of China's coast guard agencies.

Second, the Draft is clearer than the 2018 Decision of the Standing Committee of the National People's Congress on the Exercising of the Marine Right Safeguarding and Law Enforcement Functions and Powers by the China Coast Guard (hereinafter 2018 Decision), which makes the boundaries for the administrative authority of China's coast guard agency. In other words, it further strengthens their administrative attributes. The 2018 Decision only grants powers in a few matters.<sup>5</sup> In addition to the generalized powers in Article 5, which are mentioned above, Article 11 of the Draft also provides specific boundaries for power, such as the provision that an empowered agency be: "(I) responsible for carrying out cruising and vigilance in waters under Chinese jurisdiction, guarding key islands and reefs, administering maritime delimitation lines, and preventing, stopping, and eliminating acts that endanger national sovereignty, security, and maritime rights and interests. (II)

---

1 Luo Haocai, (1996). *Administrative Law* [M]. Beijing: Peking University Press, 76.

2 Hu Jianmiao, (2003). *Administrative Law* [M]. Shanghai: Fudan University Press, 78-79.

3 Zhu xuelei, (2015). The Identity Dilemma of "Organization Authorized by Laws and Regulations" and Its Solution——from the Perspective of Administrative Litigation. [J] *Jiangnan Academic*, 34(06):5-11.

4 Article 2 of the Coast Guard Law of the People's Republic of China (Draft, 2020 version) provides that "coastal police agencies are important maritime armed forces and national administrative law enforcement forces."

5 Article 1 of Decision of the Standing Committee of the National People's Congress on the Exercising of the Marine Right Safeguarding and Law Enforcement Functions and Powers by the China Coast Guard provides that "China Coast Guard performs maritime rights enforcement duties, including enforcement tasks in combating maritime illegal and criminal activities, maintaining maritime security, marine resource development and utilization, marine ecological environment protection, marine fishery management, maritime anti-smuggling, etc., as well as coordinates with and guides local maritime law enforcement."

Responsible for the safety and security of important maritime targets and major events, taking necessary measures to protect key islands and the safety of artificial islands, installations and structures in the exclusive economic zone and continental shelf...” and so on.

Third, the Draft makes a series of special provisions on administrative enforcement procedures, and a bottom-up design – namely the application of general administrative law – when there is no provision.<sup>1</sup>This provision also aligns with the definition of the administrative attributes of the marine police agencies.

Fourth, the Draft provides that when an administrative relative is not satisfied with the penalty imposed by the marine police agency, he or she can file a review and a lawsuit<sup>2</sup>. Since the 2018 reform, due to a lack of research by some people, they have not understood whether they could seek redress when dealing with China Coast Guard, nor did they know how to proceed in doing so, but the clear provisions in the draft law eliminate these doubts.

In conclusion, the Draft makes clear provisions for the administrative attributes of China’s Coast Guard agencies, but it should be well understood that the current law has not yet been formally materialized and can only be further confirmed once it has been formally adopted and an official text has been issued.

#### **IV. Unclarified Points in *The Coast Guard Law (Draft)***

There are some new provisions in *the Coast Guard Law (Draft)*. However, those provisions need to be clarified and require further discussion as to how they should be applied.

Firstly, in general, Article 17<sup>3</sup>, Article 18<sup>4</sup>, and Article 19<sup>5</sup> – on the application of the law enforcement power – are fine, but they are limited to foreign organizations and

---

1 Article 33 of Coast Guard Law of the People’s Republic of China (Draft, 2020 version) provides that “the procedures for maritime police agencies to carry out maritime administrative law enforcement, if not stipulated in this law, are applicable to the relevant laws such as the Law of the People’s Republic of China on Administrative Penalty, the Administrative Compulsion Law of the People’s Republic of China, and the Public Security Administration Punishments Law of the People’s Republic of China.”

2 Article 72 of Coast Guard Law of the People’s Republic of China (Draft, 2020 version) provides that “individuals and organizations that are dissatisfied with the administrative actions taken by the maritime police agency have the right to apply for administrative reconsideration to the higher-level maritime police agency in accordance with the provisions of the Administrative Reconsideration Law of the People’s Republic of China.

3 Article 17 of Coast Guard Law of the People’s Republic of China (Draft, 2020 version) provides that foreign organizations and individuals who, without the approval of the competent authorities of China, construct buildings and structures and install various kinds of fixed or floating devices in the sea areas and islands and reefs under China’s jurisdiction shall be ordered by the coast guard to stop their illegal acts or make rectification within a time limit. If the coast guard refuses to stop the illegal act or make rectification within a time limit, the coast guard may, when necessary, forcibly remove it according to law.

4 Article 18 of Coast Guard Law of the People’s Republic of China (Draft, 2020 version) provides that if foreign military vessels and foreign government vessels used for non-commercial purposes violate Chinese laws and regulations in waters under China’s jurisdiction, the coast Guard shall have the right to take necessary vigilance and control measures to stop them and order them to leave the relevant waters immediately. For those who refuse to leave and cause serious harm or threat, the coast guard shall have the right to take measures such as forced eviction or forced towing.

5 Article 19 of Coast Guard Law of the People’s Republic of China (Draft, 2020 version) provides that the national sovereignty, sovereign rights and jurisdiction in the sea is the violation by foreign organizations or individuals or face the danger of violation of pressing, coastguard agency shall have the right, in accordance with this law and other relevant laws and regulations, and to take all necessary measures, including weapons, to stop the infringement and eliminate the danger on the spot.

individuals, which raises the question of whether the above-mentioned provisions can be applied when the administrative counterparts are Chinese organizations and individuals. On one hand, it can be suggested that, since it applies to all foreign subjects, it is also applicable to domestic subjects; on the other hand, it can also be argued that it is a special provision for foreign subjects and should not apply to domestic subjects. In any case, this issue should be taken into account in further consideration of the Draft and in future law enforcement practice.

Secondly, Article 25<sup>1</sup> stipulates that China Coast Guard shall exercise its authority in the contiguous zone, but can it also exercise its authority in the exclusive economic zone (EEZ), or on the continental shelf? Can the corresponding authority be exercised on the high seas – in the deep seabed mining areas under our jurisdiction? There are currently no regulations. This also needs further clarification.

Translators: YUE Shan, CHEN Ze,  
CAO Jie, DENG Chi Fei  
Editor (English): John Martin

---

1 Article 25 of Coast Guard Law of the People's Republic of China (Draft, 2020 version) provides that in order to prevent and punish acts violating the relevant laws and regulations concerning safety, customs, finance, sanitation or entry and exit administration in China's land territory, internal water or territorial sea, the coast guard organs have the right to exercise control over the contiguous zone and take administrative coercive measures or other measures prescribed by laws and regulations in accordance with law.





# 专属经济区外籍船舶碰撞的海难救助和 油污损害责任问题

——交通运输部上海打捞局与普罗旺斯船东 2008-1 有限公司、法国达飞轮船有限公司、罗克韦尔航运有限公司海难救助与船舶污染损害责任  
纠纷案

郭中元\* 俞世峰\*\*

**内容摘要：**海难救助和防污清污之间呈现出“行为竞合，性质分立”之特点，对于兼具二者的应急措施，应依据其目的、船舶所面临的风险以及实际作业内容进行分析判断。互有过失的船舶碰撞导致油污损害赔偿的，非漏油船一方作为有过错第三人应按照其过错比例承担污染损害赔偿赔偿责任。

**关键词：**船舶碰撞 难救助 污损害赔偿

日前，交通运输部上海打捞局与普罗旺斯船东 2008-1 有限公司、法国达飞轮船有限公司、罗克韦尔航运有限公司海难救助与船舶污染损害责任纠纷一案于 2019 年 9 月 20 日在最高人民法院完成再审。后入选为“2019 年全国海事审判典型案例”。该案对海难救助与防污清污作业的区分、船舶碰撞中非漏油船一方的油污损害赔偿责任的承担等问题的裁判具有典型性和权威性，具有重要参考价值。本案法律关系复杂，本文择要述评。

## 一、案情与裁判

### （一）案情

2013 年 3 月 19 日 0032 时，普罗旺斯船东 2008-1 有限公司（下称“普罗旺斯公司”）所有并由法国达飞轮船有限公司（下称“达飞公司”）经营的英国籍“达飞

---

本文为国家社科基金重大项目（16ZDA073）和海南省法学会重点课题（hnfx2018a14）的阶段  
性成果之一。

\* 郭中元，海南省南海政策与法律研究中心研究人员，海南大学法学院国际法博士研究生，研  
究方向：海洋法、海商法。电子邮箱：guozhongyuan\_chn@163.com。

\*\* 俞世峰，海南大学法学院讲师，法学博士，研究方向：国际法、海商法。

©THE AUTHOR AND MARITIME LAW AND POLICY

佛罗里达”轮与罗克韦尔航运有限公司（下称“罗克韦尔公司”）所有的巴拿马籍“舟山”轮在长江口灯船东北约124海里的东海海域发生碰撞，致使“达飞佛罗里达”轮五号燃油舱严重破损，产生燃油泄漏。上海海事局事后调查评估认定上述泄漏燃油入海量共计约613.278吨。上海海事局、上海海上搜救中心自当日1200时起，先后协调、组织包括交通运输部上海打捞局（以下简称上海打捞局）在内的多家单位启动应急行动。为了防止“达飞佛罗里达”轮船体断裂沉没及便于应急处置工作的开展，上海海上搜救中心于3月21日约0430时组织“达飞佛罗里达”轮起锚往洋山港方向航行。在此过程中安排船舶沿途清污，初步实施了破损货舱内油污水过驳作业，后于24日1310时根据“边抢险、边清污、边移泊、边观察”方案组织该轮在六艘专业救助船、专业清污船的伴航下起锚，沿途救助船和清污船保持即时清污；途中在多个锚泊地进行油污水过驳、集装箱系固与卸载、破损处外翻钢板切割、灭火等作业；4月4日安全抵达舟山的船厂。经过17个昼夜的海空配合连续作业，载有6100余吨燃油的“达飞佛罗里达”轮避免了沉没断裂，中国海域也避免了灾难性污染事故的发生。<sup>1</sup>

## （二）控辩争议与裁判

上海打捞局申请再审称：上海打捞局对“达飞佛罗里达”轮实施的作业，属于国家主管机关控制的救助作业；如果上海打捞局的抽油行动属于防污清污措施，普罗旺斯公司、达飞公司应当对案涉防污清污费承担全部赔偿责任，罗克韦尔公司也应当按照50%的过错比例承担赔偿责任。对此，普罗旺斯公司、达飞公司辩称上海打捞局所从事的作业并不构成海难救助。罗克韦尔公司持同样的观点，此外还提出依据“谁漏油，谁负责”原则，罗克韦尔公司作为非漏油船舶所有人无须承担责任。最终，最高人民法院认定：上海打捞局“深潜号”轮、“联合正力”轮、“德泳”轮分别从事海难救助与防污清污作业；“舟山”轮没有漏油，但其因部分驾驶过失与“达飞佛罗里达”轮发生碰撞，导致“达飞佛罗里达”轮漏油造成污染，应当按照有关生效判决确定的50%过错比例承担污染损害赔偿赔偿责任。<sup>2</sup>

## 二、评析

### （一）海难救助与防污清污作业的区分

引发对上海打捞局案涉应急行动定性争议的主要原因在于没能正确认识海难救助与防污清污作业的关系以及本案所呈现的“行为竞合，性质分立”之特点。海难救助，是指在海上或在与海相通的可航水域对遇难的人员、船舶和其他财产进行援助、救助的行为。<sup>3</sup>通常情况下，海难救助是指对物救助。《1989年国际救助公约》第1条（a）规定“救助作业系指可航水域或其他任何水域中援救处于危险中的船

<sup>1</sup> 交通运输部上海打捞局、普罗旺斯船东2008-1有限公司申请扣押船舶再审民事判决书，最高人民法院民事判决书，（2018）最高法民再368号。

<sup>2</sup> 交通运输部上海打捞局、普罗旺斯船东2008-1有限公司申请扣押船舶再审民事判决书，最高人民法院民事判决书，（2018）最高法民再368号。

<sup>3</sup> 张湘兰主编：《海商法》，武汉大学出版社2008年版，第231页。

船或任何其他财产的行为或活动”。然海难救助可包括对环境救助，鼓励保护海洋环境原则已成为现代海难救助法的基本原则之一。《1989年国际救助公约》序言指出“认识到及时有效的救助作业，对处于危险中的船舶和其他财产的安全以及对环境保护能起重大的作用”。该公约进一步在第14条规定了对救助人在防止或减轻对环境损害方面的技能和努力”作为评定报酬的标准之一。可见，海难救助与采取和防止、减轻油污损害措施之间可以共存，在对海难采取的应急救援行动中，可能两者兼有。因此，认定某项海上应急行动究竟是海难救助抑或防污清污，需要结合作业的初始目的、船舶所面临的风险、实际作业内容等事实进行分析判断。中国《最高人民法院关于审理船舶油污损害赔偿纠纷案件若干问题的规定》第11条也规定了兼具海难救助和防污减污作业的费用问题。

本案所涉作业活动呈现出“行为竞合，性质分立”之特点。本案最高院纠正了一、二审法院“一刀切”的做法，对有关作业的目的、内容及所面临的危险进行主观考察和客观分析，从而对三艘参与轮的行为进行了准确定性。

首先，对作业初始目的的判断。最高院通过对比上海海上搜救中心分别向上海打捞局和鑫安公司发出的两份任务书，发现前者要求“派力量前往救助”，后者要求“前往现场清除污染”，从而认定向上海打捞局发出的表明了救助意图。虽然协调书性质有待认定，但从书证的证明性理论可知，前者的救助意图明确，且不受嗣后行为的影响。故该判定准确。

其次，对事故船舶所面临的风险的判定。尽管“达飞佛罗里达”轮船长发出的海事声明中没有发出求救信号及具体请求的记载。但最高院依据船东互保协会的验船师报告、中国船级社上海分社的报告、达飞公司提出避风申请的陈述等反映的客观情况断定“达飞佛罗里达”轮处于真实的危险之中。最高院通过客观、整体的分析准确的判定“达飞佛罗里达”轮直接且迫切危险而不是仅依据该轮船长发出的海事声明，具有合理性和科学性。需要指出的是，海难救助中所指的危险，并不要求是绝对的（absolute）或即刻发生的（immediate），只要是根据当时的具体情形，合理地预计该危险不可避免，即可以满足海难救助的要件。<sup>1</sup>不需要实际或立即的遇险（distress）；只要有不幸（misfortune），就可能使船只在没有援助的情况下面临破坏风险。<sup>2</sup>因此，一、二审法院以该轮在碰撞后尚能自行从而判定无直接且迫切危险不仅与事实不符，也不符合海难救助中“危险”的要求。

最后，作业性质的判定。最高院通过对参与应急行为轮船的船体属性、具体作业内容以及各类作业所占比例进行逐层分析，从而准确区分了海难救助和清污减污作业，判定了作业的最终性质。应当说最高院引入的上述标准有利于此类案件性质的准确认定，客观上也简化了相关费用的计算。本案中，“深潜号”轮系11244总吨的特种用途船，船型为深潜水工作母船，有起重能力和饱和潜水系统。特别是该

<sup>1</sup> 胡正良主编：《海事法》，北京大学出版社2016年版，第116页。

<sup>2</sup> Aleka Mandaraka-Sheppard, *Modern Maritime Law, Third Edition, Vol. 2: Managing Risks And Liabilities*, Informa Law from Routledge, 2013, p.492.

轮并非专业清污船舶。此外, 应急行动期间主要从事吊装物资及设备、潜水检查探摸、供应淡水、伴航、切割钢板等作业, 同时也从事了吊装抽油设备并抽取油污、潜水清除作业中布放的绳索等作业, 基于前一部分海难救助为其主要作业, 而后一部分防污清污作业为海难救助中附带进行的辅助作业, 特别是救助作业包括对环境的救助, 最高院将“深潜号”轮的作业全部认定为海难救助。而案涉“联合正力”轮为 3656 总吨的工程船, 在应急行动中主要从事的作业是吊装清污设备、堵漏钢板、抽油污水、清洗油污水舱, 同时还包括吊装电焊机和补给、伴航、配合起吊落水集装箱、配合切割钢板等作业。尽管上海海上搜救中心在事发当日向上海打捞局发出搜救任务协调书要求其进行救助, 但考虑到“联合正力”轮在应急行动中主要作业是防污清污, 该轮其他作业基本上是配合施救, 因此最高院以客观标准根据“联合正力”轮的实际作业内容, 将该轮从事的案涉作业全部认定为防污清污。此外, 鉴于“德泳”轮为“联合正力”轮、“深潜号”轮作业从事配合辅助工作, 因此, 最高院根据“联合正力”轮、“深潜号”轮作业的性质, 分别认定其作业的性质为海难救助与防污清污。

## (二) 非漏油船舶污染损害赔偿责任问题

两船或者多船互有过失碰撞致一船漏油造成油污损害的情形下, 非漏油方应当承担何种民事责任, 理论界和实务界一致存在争议。主要有非漏油方不承担赔偿责任、非漏油方按碰撞责任比例承担按份责任、非漏油方与漏油方承担连带责任、依受害人选择请求权的不同承担相应责任、非漏油方承担类似于一般保证的补充责任等做法或观点。<sup>1</sup> 本案中最高人民法院采用“非漏油船舶方依碰撞责任比例承担按份责任”这一观点, 从而为多年纷争画上句号, 统一了裁判标准。

最高院在判决书中使用较大篇幅进行法律适用说理。首先, 明确否定反向推理。即从《2001 年国际燃油污染损害民事责任公约》第 3.1 条关于“事故发生时的船舶所有人应当对由船上或者源自船舶的任何燃油造成的污染损害负责”的规定中不能推导出其他任何人不当负责的含义。同理, 沿袭该公约的《最高人民法院关于审理船舶油污损害赔偿纠纷案件若干问题的规定》第四条也不涉及第三人责任之旨意, 并无排除其他有过错者可能承担责任之意。这样的做法值得肯定。因并非所有法律规范都可以进行反向推理, 特别是不适用于存在例外和特殊的情况, 而海洋环境损害赔偿责任具有特殊性。其次, 准确适用国内法。即排除适用《海商法》, 而适用《侵权责任法》及其司法解释。因本案属涉外民事纠纷, 而各方当事人的一致选择适用中国法律。因此, 对于案涉问题应当优先适用国际公约, 公约没有规定的适用中国法律。而中国《海商法》和 1910 年《统一船舶碰撞某些法律规定的国际公约》对“第三人财产损失”的主要涉及“碰撞船舶和船上财产的赔偿”, 不涉及“船舶之外的其他财产赔偿”。进一步看, 《海商法》与《最高人民法院关于审理船舶碰撞纠纷案件若干问题的规定》, 都属于船舶碰撞法律规范, 然本案属于“第三

<sup>1</sup> 陈向勇, 陈永灿:《船舶碰撞油污损害赔偿非漏油方民事责任-兼评油污损害赔偿司法解释草案的新发展》, 载于《中国海商法年刊》2010 年第 4 期, 第 32-33 页。

人过错所致环境污染时第三人责任”，即使认为《海商法》第一百六十九条第二款在字面含义上可以涵盖碰撞当事船及其船上财产之外的其他财产损失，也不及《中华人民共和国侵权责任法》第六十八条及其司法解释《最高人民法院关于审理环境侵权责任纠纷案件适用法律若干问题的解释》处理该问题更为妥当，况且前述规定一致。故，不适用中国《海商法》而适用《侵权责任法》及其司法解释。笔者认为该法律适用规则属于“国内法补充国内其他法律规则，国内法补充国际法”，不存在所谓“特别法优先”，抑或是“新法优先”的情形。该法律适用也是合法合理的。

此外，最高院明确船舶碰撞事故中非漏油船一方的油污损害赔偿赔偿责任符合当今海洋治理的精神，也有利于节省司法资源，促进实质公平。（1）加强海洋环境保护是当今全球海洋治理中最急迫的课题之一，油轮、货轮等的巨形化使得一旦发生碰撞事故后产生的大量油类物质“事故性排放”，其污染面积大、海洋生态和环境损害重、危害时间长。在这样的背景下，对于互有过失的船舶碰撞引发海洋环境损害赔偿依然固守“谁漏油，谁赔偿”原则难以达到保护海洋环境的目的。有鉴于此，中国权威海商法学者提出“如果坚持谁漏油谁赔偿原则可能会给受害人带来不公。在此情况下，为保护油污受害人的合法权益，可以考虑允许受害人向非漏油船所有人索赔，但只能向非漏油方索赔该船的过失比例部分”。<sup>1</sup>（2）节省司法资源，促进实质公平。若严守“谁漏油，谁赔偿”原则，依据《最高人民法院关于审理船舶油污损害赔偿纠纷案件适用法律若干问题的解释》第4条的规定，受损害人需要先起诉漏油船舶一方要求其承担全部油污损害赔偿。之后，漏油船舶一方再起诉存在过失的非漏油一方，要求其根据过失程度承担相应的赔偿责任。此种赔偿方式不但加重了漏油船一方的诉讼负担，若遇到非漏油船一方无力承担赔偿责任的情形，漏油船一方相当于事实上承担了所有的赔偿责任。可见，此种情况下，固守“谁漏油，谁赔偿”原则不但浪费司法资源且可能产生实质上的不公平。

---

<sup>1</sup> 韩立新，司玉琢：《船舶碰撞造成油污损害民事赔偿责任的承担》，载于《中国海商法年刊》2003年第14卷，第221页。

# Marine Salvage and Liability Concerning Oil Pollution Damage Caused by the Collision of Foreign Vessels in the EEZ

Shanghai Salvage Bureau of Ministry of Transport

v.

Provence Shipowner 2008-1 Ltd, CMA CGM SA, Rockwell Shipping Ltd.

Guo Zhongyuan\*      Yu Shifeng\*\*

**Abstract:** Marine salvage and pollution can be concurrent with decontamination in behavior yet separate in nature (行为竞合性质分立). The emergency measures for the ships involved should be analyzed and judged according to the risks they faced and the actual activities undertaken. In the case of oil pollution damage caused by the collision of two or more ships, the non-leaking party, as a third party at fault, shall bear liability in proportion to the degree of its faults.

**Key Words:** Ship Collision    Marine Salvage    Compensation    Oil Pollution Damage

This subject case is a typical case of marine salvage and of liability for pollution damage caused by Vessels. It has completed the second trial at the Supreme People's Court on September 20, 2019. The court's decision on the differentiation between marine salvage and pollution and decontamination, as well as the proportion of liability for oil pollution damage caused by the non-leaking party in the ships' collision, is authoritative and of great reference value. This case was selected as one of the "2019 Typical Example of Maritime Trial Cases". Due to the complicated facts and legal relations of this case, we will select the major parts to discuss herein<sup>1</sup>.

---

This article is the staged result of the key research projects (16ZDA073) and (hnfx2018a14).

\* Guo Zhongyuan is a Doctoral candidate in international law at Hainan University, a research staff at South China Sea Policy and Law Research Center. Contact: guozhongyuan\_chn@163.com.

\*\* Yu Shifeng is a lecturer at Hainan University Law School, Ph.D.in law, whose research is focused on international law and maritime law.

©THE AUTHOR AND MARITIME LAW AND POLICY

<sup>1</sup> Civil Retrial Verdict of the Supreme People's Court on Shanghai Salvage Company v. Provence Shipowner 2008-1 Ltd's, 2018, 最高法民再 No.368.

## **Facts and Judgment**

On March 19, 2013 at 00:30, the British vessel “CMA CGM Florida” (hereinafter vessel Florida) owned by Provence Shipowner 2008-1 Ltd. (hereinafter Provence), operated by the French company CMA CGM SA (hereinafter CMA), collided with the anamanian vessel “Cho Shan” owned by Rockwell Shipping Ltd. (hereinafter Rockwell) at 124 nautical miles southeast of the light vessel in Yangtze River, which caused severe damage to Bunker No.5 of CMA CGM Florida and resulted in oil leaking. The total amount of oil that leaked into the sea was 613.278 tons, based on the evaluation by the Shanghai Maritime Safety Administration. On the same day, starting at 12:00, the Shanghai Maritime Safety Administration and the Shanghai Maritime Search and Rescue Center organized rescue efforts by coordinating various rescue departments, including the Shanghai Salvage Bureau Ministry of Transport. On March 21 at 4:30, the Shanghai Maritime Search and Rescue Center instructed vessel Florida to sail into Yangshan Port, where they planned to initiate their rescue mission to prevent the vessel from breaking and sinking. On March 24 at 13:10, vessel Florida, accompanied by six salvage and waste cleaning boats, lifted anchor and sailed towards the port. On its way to the destination, salvage operations were performed at various anchor areas, such as transferring the oil sewage, securing and unloading the container, cutting off the protruding steel plates from damaged parts, and extinguishing the fire. On April 4, vessel Florida arrived safely at the shipyard. After 17 days of continuous rescue efforts from air and marine services, vessel Florida was saved, thus avoiding a disastrous spill of the oil that was onboard at the time, which totaled upwards of 6,100 tons.

## **Disputes and Judgment**

Shanghai Salvage Bureau of Ministry of Transport, the Plaintiff, applied for a retrial. The Plaintiff contended that the salvage operation was ordered by the Nation’s authorities and that pumping oil is a necessary measure in cleaning and decontamination, as well as to avoid further pollution of the sea. Provence and CMA are fully liable for the compensation of all the expenses involved in the salvage operation. Rockwell, the owner of the non-leaking vessel, shall be liable for the compensation of the expenses based on the fault ratio of 50%.

Provence and CMA argued that the operation undertaken by the Plaintiff does not constitute salvage at sea. Rockwell joined with Provence and CMA on this issue. Rockwell further argued that the liability for the salvage expense should be on the owner of the leaking ship, rather than the owner of the non-leaking ship.

The Supreme People’s Court found that Plaintiff did dispatch three boats (Shen Qian Hao, United Zheng Li, and De Yong) for the purposes of marine salvage, decontamination,

and pollution prevention. Although there was no oil leakage from Rockwell's vessel, the collision was partially due to its fault in navigation. Rockwell shall be liable for the damages, in accordance with the proportion of fault attributed, which is to be determined at 50%.<sup>1</sup>

## Comments

### *1. Distinctions between marine salvage, pollution prevention, and decontamination*

The primary causes of the dispute in this case stem from inability to recognize the connections between marine salvage, pollution prevention, and decontamination, as well as failing to recognize the characteristics of the activities. Marine salvage refers to any act or activity undertaken to assist and aid a vessel, its cargo, or any other property, including people in danger at sea or in any waters connected with the sea.<sup>2</sup> Generally speaking, marine salvage refers to salvage of properties.

However, pursuant to Article 1 (a) of International Convention on Salvage 1989, "salvage operation means any act or activity undertaken to assist a vessel or any other property in danger in navigable waters or in any other waters whatsoever". The preface of the International Convention on Salvage 1989 also states that, "...substantial developments, in particular the increased concern for the protection of the environment, have demonstrated the need to review the international rules presently contained in the Convention... Conscious of the major contribution which efficient and timely salvage operations can make to the safety of vessels and other property in danger and to the protection of the environment." In other words, environmental marine salvage and encouragement of protection of the marine environment has become one of the general principles of modern maritime salvage law. Article 14 of International Convention on Salvage 1989 provides that, if the salvor has carried out salvage operation and thus has prevented or minimized damage to the environment, he shall be entitled to a special compensation from the owner of that vessel. Article 13 further states that, to encourage salvage operations, the skill and efforts of the salvor in preventing or minimizing damage to the environment is one of the criteria taken into consideration when calculating the reward. Apparently, maritime salvage and the measures taken to prevent or minimize oil pollution damage can be coherent and coincide with each other during the emergency operation. In determining whether an operation constitutes marine salvage, pollution prevention, or decontamination, it is necessary to assess and analyze based on the original purpose of the operation, the risks faced by the vessel, and the measures taken during rescue operation. In addition, the Supreme People's Court has even specified the fees for

---

<sup>2</sup> Civil Retrial Verdict of the Supreme People's Court on Shanghai Salvage Company v. Provence Shipowner 2008-1 Ltd's, 2018, 最高法民再 No.368.

<sup>3</sup> Zhang Xianglan, *Maritime Law*, Wuhan University Press, 2008, p.231.



salvage at sea, and for pollution prevention and decontamination, in Article 11 of “Provisions of Supreme People’s Court on Issues Concerning Disputes over Compensation for Vessels Involved Oil Pollution Damages”.

In its analysis, the Supreme People’s Court has taken the following into consideration: the purpose of the task, the risks faced by the vessels, and the nature of the salvage operation.

a. The assessment of the purpose: Shanghai Maritime Search and Rescue Center sent two separate orders to Shanghai Salvage Bureau of Ministry of Transport (hereinafter as SSB) and Xinan Company, requesting the former to dispatch rescue forces and the latter to clean up the site. According to all the documented evidence, the intention of SSB to secure rescue is obvious and clear.

b. The risks faced by the vessel in collision: Even though the message sent from the captain of Vessel Florida did not specifically request salvage, the report from the ship examiner afterwards, as well as the shelter request from CMA, provide ample evidence that Vessel Florida was indeed in direct and imminent danger. Judging from the facts and evidence, the People’s Supreme Court’s conclusion is objective and scientific.

It is noteworthy that the danger referred to in the maritime salvage law does not have to be absolute or immediate. No actual or immediate distress is required, as long as it is reasonably predicted to be unavoidable under the particular situation at the time<sup>1</sup>, or if there is a misfortune that may expose the vessel to the risk of destruction<sup>2</sup>. The People’s Supreme Court overruled first and second trials’ decisions, which had found that Vessel Florida was not in danger based on the fact that it was capable of navigating without assistance.

c. The nature of the operation: The Court found that all three of the boats dispatched by SSC to rescue the leaking vessel were equipped with tools, supplies, and material for either salvage or pollution prevention purposes. Based on the actual content of the operation, and the functions of each boat respectively, the Supreme Court concluded that the operation was of maritime salvage, pollution, and decontamination nature.

## ***II. Liability and Compensation of the Non-Leaking Party for Damage Caused by Collision of Ships***

There are many different views on the liability of the non-leaking vessels in the case of oil pollution damage as a result of collision of two or more vessels at fault. They can be summarized as follows: (1) Non-leaking party shall not be liable for the damages; (2) Non-leaking party shall bear responsibilities on a pro rata basis; (3) Non-leaking party and leaking party shall be jointly and severally liable for the compensation of damages; (4)

---

<sup>1</sup> Hu Zhengliang, Admiralty Law, Peking University Press, 2006, p.116.

<sup>2</sup> Aleka Mandaraka-Sheppard, Modern Maritime Law, Third Edition, Vol.2: Managing Risks and Liabilities, Informa Law from Routledge, 2013, p.492.

The non-leaking party and the leaking party shall be commensurately liable for the compensation; (5) The non-leaking party shall bear the supplementary liability parallel to general guaranty<sup>1</sup>. In this subject case, the Supreme Court adopted the view that the non-leaking party's liability shall be based on the proportion of its fault. This decision puts an end to years of debates on this matter. The Supreme Court held a lengthy discussion of the application of these laws. Article 3, Paragraph 1 of International Convention on Civil Liability for Bunker Oil Pollution Damage 2001 states, "the ship owner shall be liable for pollution damage caused by bunker oil on or originated from the ship". Article 4 of the Provisions of the Supreme People's Court on Several Issues Concerning the Trial of Cases of Disputes Over Compensation for Oil Pollution from Vessels states, "Where the oil pollution damage arises from a both-to-blame collision of ships, the person who suffered damage may claim for full compensation against the owner of the leaking ship". Neither of the provisions above mentions the issue of a third party; however, from this, one should not infer exclusion of the possibility that a third party could be liable for compensation of the damage. Marine environmental damage has special characteristics, so applying the laws accurately is of paramount importance. The Tort Law of the People's Republic of China shall apply in this case for the following reasons: (1) This case involves foreign entities who have all accepted the application of Chinese law; (2) Chinese law will only be applied where the specific issue is not addressed in the international convention. Both Chinese Maritime Code and International Convention for the Unification of Certain Rules of Law with Respect to Collision between Vessels 1990, regulate on the issues of damage caused to the vessels, to their cargo, or to other property of the crews, passengers, or other persons on board, but not on the issue of third party liability for oil pollution due to the third party's fault. Even though Article 169 Paragraph 2 of Chinese Maritime Code contains regulations on the loss and damage caused to property, aside from the collided vessels and the property on board, Tort Law of China and its judicial interpretation by the Supreme Court shall be more appropriate in the subject case. The application of laws in this case is an example of "domestic laws complementing other domestic rules, as well as domestic laws supplementing international laws" (国内法补充国内其他法律规则, 国内法补充国际法).

### **The significance of the Supreme Court's decision**

(1) In this case, the Supreme Court takes a position which is in line with today's spirit of ocean management. Marine environment protection is currently one of the most urgent global issues. Due to the increasing size of vessels and oil tankers, a large amount of oil

---

<sup>1</sup> Chen Xiangyong, Chen Yongcan, Civil Liability of Non-Leaking Party in Compensation for Oil Pollution Damage Caused by Ship Collision and A Review on the New Development of the Draft Judicial Interpretation on Compensation for Oil Pollution Damage, Annual of China Maritime Law, Vol.4, 2010, p.32-33. (in Chinese)

spilling into the ocean during the accident would result in massive pollution and severe damage to marine ecology and the environment for a long period of time. Leading scholars of marine law in China have brought attention to the potential problems of adhering to the old principle of liability being placed solely on the owner of the leaking vessel, which is primarily that it may create difficulty in protecting the environment and result in injustice to the victim. It is suggested that the victims are entitled to the right to claim compensation from the owner of the non-leaking party for the proportion of its fault<sup>1</sup>. (2) Saving judicial resources thereby leads to substantive justice. According to Article 4 of the Provisions of the Supreme Court on Several Issues Concerning the Trial of Cases of Disputes over Compensation for Vessel-Induced Oil Pollution Damage, the victims shall first file a lawsuit against the leaking vessels to request complete compensation for pollution damages. Then, the leaking party shall bring another lawsuit against the at-fault, non-spilling party to request that the latter share in the liability, according to the determined proportion of fault. This will not only increase the litigation burden on the leaking party; in the instance that the non-leaking party is unable to pay, due to financial hardship, it will also impose all the compensation liabilities on the leaking party.

Translator: Regina Law  
Editor(English): John Martin

---

<sup>1</sup> Han Lixin, SI Yuzhuo, Civil Liability for Oil Pollution Damage Caused by Ship Collision, Annual of China Maritime Law, Vol.14, 2003, p.221 (in Chinese)



# 海域使用权出让合同约定“到期不予续期”的效力认定

——江苏瑞达海洋食品有限公司诉盐城市大丰区人民政府等海域使用权行政许可纠纷案

郭中元\*

**内容摘要：**通常情况下，海域使用权人有权在期限届满前申请续期。但政府与海域使用权人以“行政协议”约定海域使用权到期后不予续期的，若符合“合法性”“有效性”两个要件，则应认定有效。《海域使用管理法》第26条之下的“公共利益”，应是满足特定海域范围内不特定主体用海利益较为一致的方面或者说“最大公约数”。其判定应考量特定海域的价值，以“个案”形式进行具体分析。

**关键词：**海域使用权 出让合同 合同效力 公共利益

## 一、案情与裁判

### （一）案情

本案原告江苏瑞达海洋食品有限公司（下称“A方”）与被告盐城市大丰区人民政府（下称“B方”）、盐城市大丰区自然资源和规划局（下称“C方”）就海域使用权行政许可发生纠纷，遂诉至上海海事法院。

2015年8月，A方与C方签订东沙紫菜养殖海域使用权出让合同，期限为三年。2018年初，A方向B方提出海域使用权续期申请，同年5月，C方以海域使用权合同明确约定海域使用权到期后不再续期为由作出不予续期的答复。A方认为，B方对其的提出续期申请，B方未在原行政许可有效期届满前作出是否准予延续的决定，应视为准予延续。故诉请判决撤销大丰区自然资源局所作答复及对海域使用权予以续期。对此，B方和C方则认为，涉案的海域使用权出让合同和海域使用权证书上均写明到期后不再续期，申请续期不应适用于通过招投标取得的海域使用权；东沙紫菜养殖海域部分与盐城湿地珍禽国家级自然保护区以及黄海湿地申遗的提名地范围重合或邻近，部分在生态红线范围内，出于保护社会公共长远利益的需要不予续期。

---

\* 郭中元，海南省南海政策与法律研究中心研究人员，海南大学法学院国际法博士研究生。电子邮箱：guozhongyuan\_chn@163.com。本文为国家社科基金重大项目《我国南海岛礁所涉重大现实问题及其对策研究》（16ZDA073）的阶段性成果之一。

©THE AUTHOR AND MARITIME LAW AND POLICY

## （二）裁判

上海海事法院认为涉案海域使用权出让合同合法有效，故合同中“到期不予续期”的约定有效。

而《海域使用管理法》第二十六条是对一般情况下海域使用权人申请续期权利的规定，并非强制性的规定，其并不排除政府机关与海域使用权人对于使用权到期后是否续期以及续期方式通过明确约定的方式进行变更，这样的约定也并未违反法律法规的强制性规定。因此，涉案海域使用权到期后，B方和C方有权依据相关法律法规并结合海域管理开发的实际情况，决定是否继续将该海域进行出让以及出让的具体方式。此外，B方和C方以维护社会公共利益为由，决定不立即进行相关海域使用权的出让，属于依法行使海域管理职权的行政权力范围，并无不当。故，驳回原告江苏瑞达的诉讼请求。

## 二、评析

本案法院主要以双方之间海域使用权出让合同的约定决定了本案的结果。那么，除开该问题外，本案是否有其他考量因素或问题？

### （一）本案海域使用权出让合同的法律性质和效力问题

依据《最高人民法院关于审理行政协议案件若干问题的规定》第1条对“行政协议”的界定，

本案海域使用权出让合同属于行政协议。行政协议需要进行合法性审查与有效性两方面的审查。<sup>1</sup>本案中，制订海域使用权出让合同条款依法属于B方和C方的权限范围，其行为和程序符合《海域使用管理法》的规定，具备合法性。此外，双方意思表示真实，无欺诈、胁迫行为，不违反法律、行政法规的强制性规定。因此，合同及其约定合法有效。那么，该行政协议是否可排除《海域使用管理法》第二十六的规定？

行政协议的海域使用权出让合同兼具“行政性”和“协议性”，而行政协议的契约性决定了其所谓的“行政”是契约行政、协商行政，有别于传统的行政行为，因而不能完全照搬照抄有关行政行为的规定，否则，就可能会出现体系混乱甚至体系违反。<sup>2</sup>这就要求法院裁判时尊重双方的意思自治。此外，行政协议具有补充、变更甚至一定程度上排除法律规定（非强制性规定）适用的功能。只要不存在使合同无效的情形，行政相对人有权在行政协议中处分自己的部分实体或程序性权利。本案海域使用权出让合同约定“到期不续”属于对海域使用权人申请续期权利的约定放弃。在法律中，权利可以基于自愿放弃，只要不违反法律法规的强制性规定。因此，从尊重当事人“意思自治”以及政府公信力的双重视角来看，应予尊重。

<sup>1</sup> 麻锦亮：《纠缠在行政性与协议性之间的行政协议》，载《中国法律评论》2017年第1期，第60页。

<sup>2</sup> 麻锦亮：《纠缠在行政性与协议性之间的行政协议》，载《中国法律评论》2017年第1期，第59页。

## （二）行政许可逾期问题

中国《行政许可法》第 50.2 条规定“行政机关应当根据被许可人的申请，在该行政许可有效期届满前作出是否准予延续的决定；逾期未作决定的，视为准予延续”。据此，本案 A 方认为，B 方对其的提出续期申请未在原行政许可有效期届满前作出是否准予延续的决定，应视为准予延续。应当说第 50.2 条规定的本意之一是督促行政机关提高行政效率，防止因无端之拖延损害行政相对人的合法利益。本案中，A 方虽向 B 方申请续期未获答复，但是 C 方在原行政许可有效期届满前作出了不予续期的答复。而 C 方作为海洋行政管理部门，同时作为 B 方的下级机关，其答复合法有效、及时，因此，不存在行政许可逾期问题。

## （三）海域使用权续期审批的考量因素

依据《海域使用管理法》第 26 条，除根据公共利益或者国家安全需要收回海域使用权的外，海域使用权人申请续期的，原批准用海的人民政府应当批准续期。该规定具有特定的历史背景：人类对海域的需求有限，大量的海域资源还没有被利用，有人使用就比没有人利用强得多。<sup>1</sup>此外，使用海域进行开发经营活动，前期投入大、回报周期长，使用期届满之时可能前期投资尚无盈利或初步盈利，从保障海域使用权人利益以及促进社会总财富的积累的角度考虑，无特定正当理由如公共利益或者国家安全需要，原则上应予批准续期。

本案法院主要以海域使用权出让合同约定进行裁判。同时也认可 B 方和 C 方以公共利益为由不再组织对涉案海域的出让，似乎有“补强”说理的意味。但并未对此展开分析。“公共利益”这一概念具有相当模糊性，在不同法域具有不同的界定，不一而足。笔者认为，《海域使用管理法》第 26 条之下的“公共利益”，应是满足特定海域范围内不特定主体用海利益较为一致的方面或者说“最大公约数”。但究竟为何？可能取决于特定情况，如海洋渔业资源丰富区，该地区人民的“公共利益”是渔业开发，而在生态环境资源优异的地区，“公共利益”则可能是生态环境养护。就本案而言，A 方取得的海域使用权涉及的海域与江苏省海洋生态红线区毗邻，且邻近盐城湿地珍禽国家级自然保护区和申报世界自然遗产的盐城黄海湿地。鉴于邻近海域具有的较高海洋生态价值，对此进行保护符合邻近该海域范围内不特定主体利益的最大公约数——海洋生态环境利益，因此，属于“公共利益”的范畴。但是，A 方使用的海域只是邻近该海域，而并非在该海域内，鉴于本案没有述及所述海域相距的距离以及海域生态系统之间的关系等，这两者是否具有关联性依然存疑。法条中“公共利益”或“国家安全”两个概念既无确定的统一含义又无成例可援，充满不确定性。在未来的司法裁判中，似乎只能秉承该条款的价值和理念，考量特定海域的价值，以“个案”形式对当地的“公共利益”和“国家安全”进行具体分析。

<sup>1</sup> 张洪波：《海域使用权制度研究》，哈尔滨工程大学出版社 2015 年版，第 100 页。

# Contract of Sea Area Use with Non-Extension Clause

**Jiangsu Ruida Food Compay, Ltd., Plaintiff**

v.

**People's Government of Yancheng City Dafeng District and Dafeng District Natural Resource and Planning Board, Defendants**

Guo Zhongyuan\*

**Abstract:** At the expiration of the sea area use contract, the owner of the right to sea area use is entitled to apply for a contract extension to the government that originally approved the right (the “Granting Authority”). However, the government has the right to deny the application if it is necessary to revoke the right for the benefit of public interests or State security. It is at the government’s discretion to include a non-extension clause in the contract.

**Key Words:** Right to the use of sea area; Consignment contract; Contract validity; Public interests

**Background:** In August 2015, the Plaintiff, Ruida Food Company, Ltd. (hereinafter “Ruida”), through a bidding competition, signed a consignment contract with Dafeng District Natural Resource and Planning Board (hereinafter “Natural Resource Board”) for the right to use the Dongsas sea area for the purpose of breeding purple seaweed. The contract was valid for three years. In early 2018, Ruida filed an application with the Government of Yancheng City Dafeng District (hereinafter “District Government”) as the Granting Authority, for an extension of the contract. In May 2018 the Natural Resource Board advised Ruida that it was denying the application.

Ruida brought this lawsuit against both the Natural Resource Board and the District Government at Shanghai Maritime Court.

Ruida claims that Article 26 of the Law on the Administration of Sea Area Use allows the owner of the right to use to apply to the Granting Authority for an extension, where the owner of the right continues to require that right on expiration of the use period set out in the contract. In accordance with Article 26 Ruida submitted the application as it continued

---

This article is the result of the study of the key research project (16ZDA073)

\* Guo Zhongyuan, research staff at South China Sea Policy and Research Center of Hainan Province, Doctoral candidate in International Law at Hainan University Law School.

[Guozhongyuan\\_chn@163.com](mailto:Guozhongyuan_chn@163.com).

©THE AUTHOR AND MARITIME LAW AND POLICY



to need to utilize the right to use per the 2015 contract. Ruida argued that because the Natural Resource Board was not the original granting authority, the denial of the application was invalid, and the district Government and the Natural Resource Board were obligated to extend the contract.

Defendants contend: (1) Both the contract and the certificate of the right to use explicitly state that there would be no extension at the expiration of the use period. They argued that an application for extension does not apply to contracts acquired through a bidding competition. (2) The Dongsha sea area either overlaps or is in the vicinity of the Yanchan National Wetland Natural Reserve where breeding of purple seaweed is not allowed. (3) Dongsha sea area is within the red lines for ecological protection which is restricted from development. (4) Dongsha sea area either overlaps or is in close vicinity of the Yancheng Yellow Sea Wetland. In 2018, Yancheng Yellow Sea Wetland was in the process of applying for recognition as a World Natural Heritage, continued breeding of purple seaweed in the sea area would jeopardize the prospect of being granted the World Natural Heritage status. Restoring the ecology of the sea and all water-life is of great public interest. For the foregoing reasons, Ruida's claims should be dismissed.

**Court Decision:** According to Article 20 of the Law on Administration of Sea Area Use, the right to sea area use may be obtained through bidding. It is within the Defendants' authority to hold the bidding competition and formulate the contract. Article 26 of the Law on Administration of Sea Area Use provides that "where at the expiration of period for the right to the use of the sea area, the owner of the right needs to continue to use the sea area, he shall, no later than two months prior to the expiration date, apply for extension to the people's government that originally gives approval. Except where it is necessary to revoke the right for the benefit of public interests or State security, the people's government shall approve the application for extension." Article 26 is a general provision to regulate the procedure for application of extension. It is not compulsory on the people's government to approve application for extension of the use period. It is at the governing department's discretion approve or deny the application of extension, base on the current situation.,

Ruida's claims dismissed. None of the parties has made an appeal. Verdict of the first trial of the Maritime Court is final and effective.

## **Comment and Analysis:**

### **1. Character and validity of the consignment contract**

Based on Article 20, Article 26, Article 34 of the Law on Administration of the Sea Area Use, Defendants have the right to solicit biddings for the use of the sea area, to sign an agreement with the winning bidder, and to formulate the contract. The agreement of sea area use between Ruida and the Defendants is a contract of executive character and is in compliance with all the relevant laws.<sup>1</sup>The provisions of the contract explicitly stipulate that at the expiration of the contract there shall be no extension. The language in the non-extension clause is clear and precise. There is no evidence of fraud or coercion. The contract

---

<sup>1</sup> MA Jin Liang: 纠缠在行政性与协议性之间的行政协议, "China Law Review"2017, Vol. 1, p.60

shall be deemed effective and valid

## **2. Notification of the denial in time.**

According to Article 50.2, “The administrative department shall, based on the application, make the decisions of whether the permit will be extended before the expiration of the permit. In case the decision is not made by the expiration date, it shall be deemed extended.” In this case, the Natural Resource Board, as a marine executive department as well as a sub-department of Dafeng District Government, has the executive power to issue a denial to the application for an extension of the use period. Ruida was notified of the decision not to extend by the Natural Resource Board before the contract was expired.

## **3. Factors being considered.**

The Defendants have sufficient grounds to deny Plaintiff’s application by the reason of the non-extension clause in the contract. The Marine Court’s applying of the doctrine of public interests was to strengthen the Defendants position to deny the Plaintiff’s claims. Due to the fact that the majority of sea areas are not in use, it is the policy of people’s government to open the sea areas to individuals for development in aquaculture. Also, considering the time required for the return of the investors’ capital, it is usually a standard practice to extend the contract except where there are concerns in the public interests or State Security.<sup>1</sup>To date, no legislation or case law has specifically dealt with the definition of public interests or State security. As such, it is likely that cases involving these concepts will be dealt with in a case by case basis.

Translator: Regina Law  
Editor (English): Stephanie Tao Quinn

---

<sup>1</sup> ZHANG Hong Bo “The Research of the System of Right to Sea Area Use ”by Harbin Engineering University Press, 2015, p. 100. (in Chinese)



INTERNATIONAL TRIBUNAL FOR THE LAW OF THE SEA  
TRIBUNAL INTERNATIONAL DU DROIT DE LA MER

# Press Release

## RECONSTITUTION OF THE CHAMBERS OF THE TRIBUNAL

The International Tribunal for the Law of the Sea reconstituted its chambers today during its fiftieth administrative session, which is currently being held in Hamburg.

With the exception of the Seabed Disputes Chamber, which has exclusive jurisdiction in cases relating to Part XI of the United Nations Convention on the Law of the Sea (“the Convention”), disputes brought before the Tribunal are dealt with by the full Tribunal unless both parties agree to refer the dispute to a chamber.

The composition and mandates of the Tribunal’s chambers are as follows:

### **Seabed Disputes Chamber**

The Seabed Disputes Chamber has exclusive jurisdiction under Part XI, section 5, of the Convention in either contentious or advisory proceedings over disputes or questions relating to the exploration and exploitation of the seabed and ocean floor and the subsoil thereof beyond the limits of national jurisdiction. The Chamber is composed of 11 judges, who are selected by the members of the Tribunal every three years. The selection process ensures the representation of the principal legal systems of the world and equitable geographical distribution. The Chamber elects its President from among its members. The composition of the Chamber for the period ending 30 September 2023 is as follows:

President	Judge Chadha
Members	Judges Jesus, Bouguetaia, Paik, Gómez-Robledo, Cabello Sarubbi, Kittichaisaree, Kolodkin, Lijnzaad, Duan, and Brown

Four special chambers have been established in accordance with article 15 of the Statute of the Tribunal (“the Statute”); cases may be submitted to them at the request of the parties to a dispute:

### **Chamber of Summary Procedure**

This Chamber is established annually pursuant to article 15, paragraph 3, of the Statute. It may hear and determine a case by summary procedure if the parties so request. The Chamber may prescribe provisional measures if the Tribunal is not in session or a sufficient number of members is not available to constitute a quorum.

The Chamber is composed of five members and two alternates, as provided for by the Statute. The President and the Vice-President of the Tribunal are members *ex officio* of the Chamber; the President of the Tribunal presides over the Chamber. The Chamber has been constituted as follows for the period ending 30 September 2021:

President	President Hoffmann
Members	Vice-President Heidar, Judges Kateka, Kolodkin, and Lijnzaad
Alternates	Judges Kulyk and Caracciolo

Three further chambers have been established for a period of three years pursuant to article 15, paragraph 1, of the Statute:

### **Chamber for Maritime Delimitation Disputes**

The Chamber is available to deal with disputes on maritime delimitation. It consists of nine members and is chaired by the President of the Tribunal. The composition of the Chamber for the period ending 30 September 2023 is as follows:

President	President Hoffmann
Members	Vice-President Heidar, Judges Pawlak, Kulyk, Chadha, Lijnzaad, Infante Caffi, Duan, and Caracciolo

### **Chamber for Fisheries Disputes**

The Chamber is available to deal with disputes concerning the conservation and management of marine living resources. The Chamber consists of nine members. The composition of the Chamber for the period ending 30 September 2023 is as follows:

President	Judge Pawlak
Members	Judges Yanai, Bouguetaia, Paik, Attard, Gómez-Robledo, Cabello Sarubbi, Caracciolo, and Kamga

### **Chamber for Marine Environment Disputes**

The Chamber is available to deal with disputes relating to the protection and preservation of the marine environment. The Chamber, consisting of nine members, is composed as follows for the period ending 30 September 2023:

President	Judge Attard
Members	Judges Jesus, Yanai, Kateka, Kittichaisaree, Kolodkin, Infante Caffi, Brown, and Kamga

### ***Ad hoc* chambers**

In addition to the chambers established by the Tribunal, parties may request the Tribunal to constitute an *ad hoc* chamber for a particular dispute (Statute, article 15, paragraph 2). The composition of the chamber is determined with the approval of the parties, who may also choose judges *ad hoc* if the chamber does not include a judge of the nationality of either or both of the parties. Such an option therefore

combines the advantages of a permanent court with those of an arbitral body, but avoids the considerable expense that is often incurred in participating in arbitral proceedings.

To date, three *ad hoc* chambers have been constituted, dealing with the *Case concerning the Conservation and Sustainable Exploitation of Swordfish Stocks in the South-Eastern Pacific Ocean (Chile/European Union)*, the *Dispute concerning delimitation of the maritime boundary between Ghana and Côte d'Ivoire in the Atlantic Ocean (Ghana/Côte d'Ivoire)*, and the *Dispute concerning delimitation of the maritime boundary between Mauritius and Maldives in the Indian Ocean (Mauritius/Maldives)*.

Further information about the Tribunal's chambers may be found on the website at: <https://www.itlos.org/the-tribunal/chambers/>.

Note: The press releases of the Tribunal do not constitute official documents and are issued for information purposes only.

The press releases of the Tribunal, documents and other information are available on the Tribunal's websites (<http://www.itlos.org> and <http://www.tidm.org>) and from the Registry of the Tribunal. Please contact Ms Julia Ritter or Mr Robert Steenkamp at: Am Internationalen Seegerichtshof 1, 22609 Hamburg, Germany, Tel.: +49 (40) 35607-227; Fax: +49 (40) 35607-245; E-mail: [press@itlos.org](mailto:press@itlos.org)

## 《2020 联合国贸易和发展委员会海运回顾》

### — 贸易紧张和政策不确定性破坏了全球输出和商品贸易的成长

联合国贸易和发展委员会所发布的《2020 海运回顾》提供了当前与海运有关的贸易，货物供应，主要业绩指标，以及相关法律监管的最新趋势。其中一章特别阐述了从事海运相关行业者的见证及应对 COVID-19 新冠病毒的经验。

COVID-19 新冠病毒 突显了全球各国相互依赖的关系，开启了重塑海运大环境的新趋势。目前海运正处於一个关键时刻，它所面临的不只是疫情所带来的迫切问题，更要对许多情况做长期性的考量，其中包括供应链和全球化模式的转化，消费及花费习惯的改变，加强风险评估，建立韧性，加强全球可持性和低碳议程。与此同时海运必须应对日益增长的贸易保护主义和内向政策所造成的不利影响。

COVID-19 新冠病毒让人们意识到海运的重要性，它是在危机时期和复原阶段提供紧急物资运送的重要部门。联合国贸发会及其他国际机构发布了建议和指导，强调在保障港口工人和海员免受疫情影响的前题下，必须确保航运持续通畅。这些机构也强调船舶必须符合国际要求，包括卫生管理，港口维持开放以供航运和联运作业。

此次的疫情引发的全球健康和经济危机颠覆了整个海运和贸易的局势，并严重影响了经济增长前景。联合国贸发委员会预测，疫情所造成的供应链中断，需求萎缩和全球经济受到供需双重影响下，2020 国际海运贸易量将下降 4.1%。这趋势在 2019 国际海运贸易失去动力的环境下就已展开。贸易紧张和政策不确定性破坏了全球输出和商品贸易的成长。

资料来源： UNCTAD

译者： 罗暹芸

# Review of Maritime Transport 2020

海事界 11 月 14 日

The Review of Maritime Transport 2020 provides an update on the latest trends in maritime trade, supply, markets, key performance indicators, and legal and regulatory developments. It also includes a special chapter with testimonials from maritime stakeholders and their experiences in coping with the COVID-19 pandemic.

The COVID-19 pandemic has underscored the global interdependency of nations and set in motion new trends that will reshape the maritime transport landscape. The sector is at a pivotal moment facing not only immediate concerns resulting from the pandemic but also longer-term considerations, ranging from shifts in supply-chain design and globalization patterns to changes in consumption and spending habits, a growing focus on risk assessment and resilience-building, as well as a heightened global sustainability and low-carbon agenda. The sector is also dealing with the knock-on effects of growing trade protectionism and inward-looking policies.

The pandemic has brought to the fore the importance of maritime transport as an essential sector for the continued delivery of critical supplies and global trade in time of crisis, during the recovery stage and when resuming normality. Many organizations, including UNCTAD and other international bodies, issued recommendations and guidance emphasizing the need to ensure business continuity in the sector, while protecting port workers and seafarers from the pandemic. They underscored the need for ships to meet international requirements, including sanitary restrictions, and for ports to remain open for shipping and intermodal transport operations.

## **International maritime trade under severe pressure**

The global health and economic crisis triggered by the pandemic has upended the landscape for maritime transport and trade and significantly affected growth prospects. UNCTAD projects the volume of international maritime trade to fall by 4.1% in 2020. Amid supply-chain disruptions, demand contractions and global economic uncertainty caused by the pandemic, the global economy was severely affected by a twin supply and demand shock. These trends unfolded against the backdrop of an already weaker 2019 that saw international maritime trade lose further momentum. Lingering trade tensions and high policy uncertainty undermined growth in global economic output and merchandise trade.

**Source: UNCTAD**



大 会

Distr.: General  
9 September 2020  
Chinese  
Original: English

第七十五届会议

临时议程\* 项目 76(a)

海洋和海洋法

## 海洋和海洋法

### 秘书长的报告\*\*

#### 摘要

本报告所述期间为 2019 年 9 月 1 日至 2020 年 8 月 31 日，系依照大会第 74/19 号决议第 364 段的规定提交。大会在该决议中请秘书长编写一份报告，阐述与海洋事务和海洋法有关的动态和问题，包括该决议的执行情况，供大会第七十五届会议审议。按照《联合国海洋法公约》第三一九条的规定，本报告还将提交《公约》各缔约国。本报告提供资料，说明近期与海洋事务和海洋法有关的重要动态，特别是联合国及其专门机构、基金和方案以及《公约》设立的各机构内的动态。

\* A/75/150。

\*\* 本报告概述了近期最重要的动态以及有关机构、方案和机关提供的部分资料。由于大会规定的报告字数限制，海洋事务和海洋法司网站上提供了本报告未经编辑的预发本，并附有综合脚注，可查阅：[www.un.org/depts/los/general\\_assembly/general\\_assembly\\_reports.htm](http://www.un.org/depts/los/general_assembly/general_assembly_reports.htm)。

20-11684 (C) 210920 300920



请回收





## 一. 导言

1. 在当前冠状病毒病这一史无前例、充满挑战的时代，我们意识到海洋在我们的健康和福祉以及日常生活中的重要作用，海洋提供了我们吸入的大部分氧气、基本食品和药品、贸易和运输的关键环节以及文化价值和遗产的来源。海洋是气候系统的重要组成部分，对空气、水和温度的调节至关重要。在海洋深处发现的生物将在寻找解决人类目前面临的危机的办法方面发挥关键作用。
2. 然而，海洋的健康状况继续恶化。海洋和沿海生态系统继续受到包括捕鱼、航运、采矿、旅游和其他行业在内的人类活动造成的多重累积压力的负面影响，也受到与气候变化有关的冲击的负面影响。污染、海洋变暖和酸化继续对海洋生态系统的运作和生物多样性产生不利影响，对低洼沿海国、小岛屿发展中国家以及日常生活与海洋息息相关的沿海城市和社区也产生了相应影响。
3. 冠状病毒病在世界各地产生了破坏性影响，在实现《2030 年可持续发展议程》方面取得的进展受到重大影响，包括实现可持续发展目标 14 及其 10 个具体目标，其中一些具体目标预计将在 2020 年实现。
4. 随着国际社会努力结束这一大流行病，更好地恢复，<sup>1</sup> 它有机会、也有责任纠正人类与包括世界海洋在内的自然世界的关系。
5. 《联合国海洋法公约》仍然是所有这些努力和活动的法律框架，也是世界“海洋宪法”。
6. 本报告总结了与海洋事务和海洋法有关的活动和动态，包括联合国系统各实体及其他政府间组织针对大会第 74/19 号决议开展的活动。本报告的目的是协助大会每年审议和审查与海洋和海洋法有关的活动和动态。阅读本报告时，应结合联合国在本报告所述期间发布的有关海洋和海洋法的其他报告，还应结合联合国各专门机构、方案和机关以及其他政府间组织提供的更详细资料。<sup>2</sup>

## 二. 冠状病毒病对海洋问题的影响

7. 冠状病毒病在全球范围内对健康、经济和社会造成了极具破坏性的后果，包括生产以及全球供应链和价值链中断。蓝色经济的许多部门受到严重影响，特别是在小岛屿发展中国家。
8. 占全球贸易额约 80% 的国际航运大幅减少。由于国际旅行方面的普遍限制，海洋和沿海旅游业也大幅下滑。虽然对各国和区域渔业部门的影响各不相同，但渔业产品需求、生产和供应普遍下降，海洋渔业和水产养殖产品的价格也是如此。由于餐厅和酒店关闭，消费者需求下降，而航班取消、贸易路线中断以及卫生措施可能增加都影响了价值链。在遵守社交距离要求方面面临的挑战也

---

<sup>1</sup> 见 [www.un.org/en/coronavirus/un-response](http://www.un.org/en/coronavirus/un-response)。

<sup>2</sup> 所有资料可查阅：[www.un.org/depts/los/general\\_assembly/contributions75.htm](http://www.un.org/depts/los/general_assembly/contributions75.htm)。

影响了船舶运营，特别是小型沿海船舶。随着通信、商业、远程工作、远程医疗和远程教育方面的使用量增加，对承载世界因特网流量约 99% 的海底电缆的依赖增加了约 25% 至 50%。

9. 海员和渔民受到严重影响。世界上有 940 万渔民，其中 90% 生活在发展中国家，很多渔民无法工作。预计对航运业雇用的 200 万海员造成巨大的影响。健康和安全方面的担忧比比皆是，港口关闭和旅行限制给海员离船和更换船员、在岸上求医和被遣返造成了困难。能力减弱、封锁措施和检疫要求影响了救援工作，并导致在海上获救的难民和移民迟迟无法登岸。

10. 人类活动减少对某些海洋物种和生态系统带来积极影响；然而，人口迁移以及沿海和近岸地区维持生计和手工捕鱼活动增加，给脆弱的鱼类种群带来了额外的压力。有报告称，人们对冠状病毒病对鱼类种群管理的负面影响以及监测、控制和监督活动减少导致非法、未报告和管制捕捞活动可能增加表示关切。冠状病毒病造成的医疗、危险和塑料废物增加以及相关的卫生状况和封锁，加上回收利用减少，可能会对健康和环境造成负面影响。

11. 冠状病毒病影响了与海洋有关的工作方案的实施。各种会议和讲习班被取消、推迟或以替代方式举行。2020 年联合国支持落实可持续发展目标 14 即保护和可持续利用海洋和海洋资源以促进可持续发展会议推迟举行，根据《公约》的规定就国家管辖范围以外区域海洋生物多样性的养护和可持续利用问题拟订一份具有法律约束力的国际文书政府间会议第四届会议和联合国海洋和海洋法问题不限成员名额非正式协商进程第二十一次会议也同样推迟举行。参与解决海事争端的国际法庭的工作和各种能力建设活动也受到影响。

12. 旅行限制和社交距离要求扰乱了数据收集调查和向决策者提供信息的工作。将资源转用于冠状病毒病疫情的管理和恢复工作可能会导致海洋科学资金减少，并影响今后的缓解和适应工作。

13. 尽管如此，还是确定有机会应对冠状病毒病，包括今后建立有效、有韧性和可持续的治理框架，作为海洋管理和可持续发展的基本前提。更多的在线互动提供了机会，包括进行能力建设以及交流和传播经验教训和最佳做法的机会。

### 三. 法律和政策框架

14. 管理所有海洋活动的国际法律制度由多方面的全球、区域和双边法律文书以及在《公约》规定的总体法律框架内通过的国内法和条例组成，并辅之以一系列不具法律约束力的文书，包括《2030 年议程》，以及大会关于海洋和海洋法以及关于可持续渔业的年度决议，其中提供了国际商定的政策指导、承诺、目标和具体目标。

15. 2019 年 11 月 16 日是《公约》生效 25 周年之日。认识到《公约》对海洋可持续发展 and 加强国际和平、安全与合作的突出贡献，同时呼吁尚未批准或加入《公约》的国家批准或加入《公约》，并呼吁所有缔约国紧急支持其全面执行。

16. 必须继续努力在普遍参加《公约》及其执行协定方面取得进展。截至 2020 年 8 月 31 日,《公约》有 168 个缔约方,《关于执行 1982 年 12 月 10 日〈联合国海洋法公约〉第十一部分的协定》有 150 个缔约方。1995 年通过的《执行 1982 年 12 月 10 日〈联合国海洋法公约〉有关养护和管理跨界鱼类种群和高度洄游鱼类种群的规定》的协定》缔约方数目从 90 个增至 91 个。

17. 通过在全球和区域一级制定更多法律和政策文书,《公约》规定的法律框架继续得到加强,尽管这些努力因冠状病毒病而受阻。虽然根据《公约》的规定就国家管辖范围以外区域海洋生物多样性的养护和可持续利用问题拟订一份具有法律约束力的国际文书政府间会议第四届会议被推迟,但会议主席启动了在线闭会期间工作。

18. 为落实《2030 年议程》和可持续发展目标、包括目标 14 而作出的努力也在继续。2019 年 12 月,目标 14 具体目标 14.c 的指标分类从三级改为二级。为该指标采取的方法包括通过各国填写调查表形式进行的自我报告工作,该调查表将由指标的保管机构即海洋事务和海洋法司分发。

19. 在 2020 年 2 月举行的 2020 年联合国支持落实可持续发展目标 14 会议的筹备会议上,各代表团审议了互动对话的主题和政府间商定宣言的内容。互动对话的八个主题已经敲定,包括“通过落实《公约》所述国际法加强海洋和海洋资源的养护和可持续利用”。<sup>3</sup> 虽然会议被推迟,但大会将适时决定筹备进程的新日期和新期限。

#### 四. 海洋空间

20. 尽管冠状病毒病造成了影响,包括推迟会议和调整业务,但《公约》规定的机构,即大陆架界限委员会、国际海底管理局和国际海洋法法庭,继续为加强海区和海洋边界的法律确定性作出贡献。

21. 除其他活动外,该委员会通过了两套建议,并决定设立一个新的小组委员会。考虑到冠状病毒病,该委员会推迟了第五十三届会议。

22. 海管局针对其 2019 年和 2020 年战略计划编制了第一次业绩指标评估报告。作为优先事项,海管局理事会继续审议“区域”内矿物资源开发规章草案,将其作为采矿法规的一部分,包括为此设立三个非正式工作组。海管局第二十六届会议第二期会议推迟到 2020 年 10 月举行,并将以缩减形式举行。

23. 在和平解决争端方面,法庭设立了一个特别分庭,审理毛里求斯和马尔代夫在印度洋的海洋划界争端案(毛里求斯诉马尔代夫)(第 28 号案件)。“San Padre Pio”号油轮(第 2 号)案(瑞士诉尼日利亚)(第 29 号案件)已提交法庭。

24. 国际法院应肯尼亚的请求推迟了印度洋海洋划界案(索马里诉肯尼亚)的公开听证,并延长了危地马拉的领土、岛屿和海域主张案(危地马拉诉伯利兹)提出诉

<sup>3</sup> 关于会议筹备进程的信息可查阅: [www.un.org/en/conference/ocean2020](http://www.un.org/en/conference/ocean2020)。

状的时限。法院在 1899 年 10 月 3 日的仲裁裁决案(圭亚那诉委内瑞拉)中通过视频会议开始审议。

25. 常设仲裁法院管理根据《公约》提起的四个案件,其中三个正在进行中。*Duzgit Integrity* 号油轮仲裁案(马耳他诉圣多美和普林西比)于 2019 年 12 月 18 日结束,作出了赔偿裁决。

26. 我以《公约》保存人的身份收到了缔约国交存的几份标明基线和海区外部界限的海图和(或)各点地理坐标表。

## 五. 人的方面的重要性

27. 海洋的健康与所有人的福祉息息相关。最不发达国家和小岛屿发展中国家的沿海社区和人口尤其依赖海洋和海洋资源实现粮食安全、运输、生计、娱乐和经济发展。海洋是许多人、特别是沿海社区和土著人民的文化习俗和遗产、社会身份、价值观和生活方式的组成部分。

28 海洋面临的多重和累积压力对最不发达国家和小岛屿发展中国家以及弱势群体、特别是妇女和女童造成了巨大影响。冠状病毒病加剧了对人类的真正影响,加深了原已存在的不平等,暴露了社会、政治和经济体系的脆弱性。除了这场危机造成的公共卫生威胁外,更广泛的经济和社会混乱还威胁到数百万人的生计、粮食安全和福利,特别是海上工作者和海上移民。

29. 国际社会继续努力,按照《2030 年议程》目标 5 的设想,在海洋相关部门实现性别平等并增强妇女和女童权能。联合国粮食及农业组织(粮农组织)支持举办区域讲习班和会议,以促进在水产养殖和渔业中实现性别平等主流化和增强妇女权能。粮农组织正在制定关于小型渔业立法的指导意见,以便在努力使国内立法与《公约》保持一致的过程中解决人权和性别平等问题。2019 年世界海事日的主题是“增强海事界妇女权能”。

30. 冠状病毒病有可能导致在实现性别平等方面取得的成果倒退,对妇女的经济和生产生活造成巨大影响。因此,像在其他部门一样,海洋部门原已存在的性别不平等现象可能会加剧。这场危机使人们重新认识到必须实现性别平等,必须在紧急措施和长期恢复工作中应用“性别平等视角”,以解决性别不平等问题,建设一个更平等、更坚韧的世界。

### 海上劳工

31. 海员和渔民继续面临非常艰难的海上工作条件,捕鱼仍然是世界上最危险的职业之一。除了冠状病毒病带来的其他社会和经济困难外,冠状病毒病和相关的应对措施,包括在人身安全和健康、工作条件、海员和渔民上船和离船能力方面采取的措施,使具有挑战性的劳动条件进一步恶化。

32. 报告的具体挑战包括船上个人防护设备和医疗服务不足;无法获得岸上医疗服务和社会福利服务;以及精神压力、孤立感和社会压力加大。由于冠状病毒病的原因,船舶运营商无法更换船员,导致船员在船上的时间延长,这一问题尤为

突出。海员和渔民面临的挑战包括单方面或非法延长工作时间、长时间关闭在被命令抛锚或停泊在偏远泊位的船上以及单方面终止合同，有些人由于旅行限制而无法离开船只、被遣返或寻求紧急医疗援助。遗弃海员事件继续发生，而针对冠状病毒病采取的一些措施给解决遗弃案件带来了额外的挑战，并可能引发新的案件。

33. 必须进一步作出努力，使每个国家履行义务，在船舶的人员配备、劳动条件和船员培训方面对悬挂本国国旗的船舶采取保证海上安全所需的措施，同时考虑到适用的国际文书。为了提高安全标准，从而改善渔民的工作条件、福利和福祉，并协助打击非法、未报告和无人管制的捕捞活动，48个国家签署了关于1977年《国际渔船安全托雷莫利诺斯公约》的1993年《托雷莫利诺斯议定书》有关规定执行情况的2012年开普敦协定(《开普敦协定》)的《托雷莫利诺斯宣言》。

34. 国际劳工组织、国际海事组织(海事组织)、粮农组织和其他联合国专门机构和机关继续协调行动，确保海员和渔民有体面的工作，并与其他行业行为者协调行动，包括针对冠状病毒病的行动，结果制定了广泛的指导文件、政策简报、建议和联合声明，呼吁关注海员和渔民的特别脆弱性，并采取具体行动减轻这些影响。

## 海上移民

35. 冠状病毒病给数以千计的难民和移民带来了新的挑战，这些难民和移民已经在冒着生命危险，通过危险的海上旅行来逃离冲突、迫害和其他困境。大流行应对措施，包括加强边境限制和检疫要求以及削减搜救能力，导致迟迟不能登岸和被拒入境。妇女、女童和具有不同性取向和性别认同的个人面临的贩运、剥削和虐待风险更高，在获得信息、庇护和保护方面面临更多挑战。

36. 2019年9月至2020年6月期间，约有71400人渡过地中海前往欧洲，据信已有765人死于海上。联合国人权事务高级专员办事处(人权高专办)和联合国难民事务高级专员公署(难民署)报告说，2020年离开利比亚的人数大幅增加。与此同时，由于人道主义搜救船停航、欧洲联盟海军部队地中海索菲亚行动的海军资产被暂停使用，以及冠状病毒病造成影响，地中海的救援能力大幅减弱。有报告称未能向遇险船只提供援助并逼退这些船只，人权高专办注意到对此表示的关切。

37. 在本报告所述期间，超过8400名难民和移民在地中海被拦截，并被送回利比亚，尽管难民署以存在安全风险和可能被羁押在不安全的条件下为由提出了相反的咨询意见。根据国际法，利比亚没有资格成为海上获救难民和移民安全登岸的地点。将难民和移民送回的做法还可能违反不推回原则。

38. 在安达曼海和孟加拉湾也仍然有人通过危险的渡海行为前往马来西亚。2019年1月至2020年6月，约有3300名罗兴亚人踏上了这样的旅程，自2020年1月以来，至少有170人死亡或失踪。一些船只被拦截或逼退，以防止人们登岸，导致他们在海上滞留数月，处于绝望的境地。难民署与国际移民组织和联合国毒品和犯罪问题办公室(毒品和犯罪问题办公室)一道，呼吁各国加强协调，以解决难民和移民流动问题。《关于偷运人口、贩运人口和有关跨国犯罪的巴厘进程》规划和筹备工作队举行了一次会议，目的是解决对非正常移民的海上保护问题。

39. 尽管面临持续的冲突、人道主义危机和日益加剧的受剥削和受虐待风险，但难民和移民继续通过海路前往也门。2020 年第一季度，超过 27 000 人离开索马里和吉布提。由于局势不安全，还有很多索马里人从也门返回，但他们在渡海时遇到了困难，包括船只倾覆。

40. 难民署倡导采取有效、合作和注重保护的方式开展搜救和登岸工作，包括与沿海国、当地社区和其他利益攸关方互动接触。在印度尼西亚、马来西亚和孟加拉国与国家海岸警卫队机构开展了能力建设倡议。

## 六. 海上安全和安保

41. 海上安全和安保继续受到国际社会的优先关注，因为它对船上生活、生计、国际贸易、能源安全和全球经济至关重要。尽管面临一系列下行压力，但 2018 年海运贸易量达到 110 亿吨，约占全球贸易额的 80%。

42. 冠状病毒病对航运业以及海员和渔民产生了重大影响，包括在实施海上安全措施方面，如检查和认证，以及确保海上安全的措施，包括限制海上警务和执法。为应对这些影响作出了努力。国际航运在与冠状病毒病有关的食物和医疗用品等必需品的供应中发挥了关键作用。

43. 海事组织继续评估文书对具有不同自主程度的船只的适用性，包括为此开展海面自主船监管范围界定工作。在海事组织制定规则的过程中，在制定和适用目标型标准方面也取得了进展。用于核查散装货船和油轮是否符合目标型船舶建造标准的订正准则于 2020 年 1 月 1 日生效。为在极地水域作业的船舶制定措施的工作也在继续。对未根据《国际海上人命安全公约》获得认证的船舶采取了临时安全措施。还努力提高国内渡轮的安全。

44. 世界气象组织(气象组织)继续与海事组织和国际水道测量组织就协调和标准化的气象和海洋信息、预报和预警服务开展协作。国际水道测量组织继续与海事组织合作，制定关于水道测量信息的标准和指南，并支持全面实施“电子航海”。国际水道测量组织和联合国教育、科学及文化组织政府间海洋学委员会继续实施世界大洋深度图项目和“海底 2030”项目，后个项目宣布将 1 450 万平方公里的新测深数据纳入最新的海图网格。

45. 针对船只的海盗活动和武装抢劫仍然是海上安全的主要威胁。虽然与 2018 年相比，2019 年全球报告的实际和未遂行为减少了约 13.5%，但与 2019 年同期相比，2020 年上半年发生的事件增加了约 20%，亚洲增加了近一倍，这可能部分归因于冠状病毒病带来的挑战。在全球范围内，受海盗和武装抢劫船只影响最严重的地区是西非(67 起事件)、马六甲海峡和新加坡海峡(45 起事件)以及南海(34 起事件)。虽然没有报告称在索马里海岸线附近水域发生海盗或武装抢劫船只事件，但索马里海盗继续对国际航运构成潜在威胁。

46. 特别令人关切的是，2019年，海员仍然面临个人风险，134人被绑架，59人被扣为人质。2020年上半年，共有54人被绑架，23人被扣为人质。大约90%的绑架事件发生在几内亚湾。

47. 继续通过索马里沿海海盗问题联络小组、亚洲打击海盗和武装抢劫船舶行为区域合作协定信息共享中心和几内亚湾之友小组等渠道，开展打击海盗行为的国际合作。安全理事会通过了关于索马里沿海海盗和海上武装抢劫的第2500(2019)号决议。海事组织、毒品和犯罪问题办公室以及海洋事务和海洋法司继续就这一问题开展工作。

48. 继续努力打击海上其他犯罪或非法活动，包括恐怖主义、非法贩运麻醉药品和精神药物、非法贩运核材料和火器、蓄意和非法破坏海洋环境、贩运人口和偷运移民以及渔业部门的非法活动。加强各国预防和应对这类活动的的能力，包括为此开展技术援助和其他方案，仍然是一个具体重点。毒品和犯罪问题办公室海上犯罪问题全球方案于2020年7月推出了第三版《海事犯罪：刑事司法从业人员手册》。

## 七. 气候变化

49. 根据政府间气候变化专门委员会2019年发布的《关于气候变化中的海洋和冰冻圈的特别报告》，海洋吸收了气候系统90%以上的过剩热量，自1970年以来变暖势头有增无减，变暖速度自1993年以来增加了一倍多。2020年第一季度，海洋热量处于有记录以来的第二高水平。人类活动排放的二氧化碳除了是造成全球变暖的主要原因外，也会被海洋吸收，加剧酸化并导致脱氧。

50. 全球平均海平面目前处于有高精度测高记录以来的最高水平。随着大陆冰体损失和海洋热膨胀速度加快，预计海平面将继续加速上升。温度的进一步上升和酸化进一步加剧基本上是必然的，变化的速度和幅度取决于未来的温室气体排放情景。

51. 沿海生态系统因海洋变暖、酸化、脱氧、海平面上升和极端天气事件以及来自人类的压力而受到不同程度的威胁。其中一些影响已导致在过去的100年里丧失近一半沿海湿地，并导致世界各地的珊瑚礁退化。

52. 海洋变暖、海冰丧失和生物地球化学变化也在改变物种构成和丰度，影响生态系统服务和生物量生产。由于全球变暖和生物地球化学变化，鱼类和贝类种群减少，这已经导致渔业渔获量减少，可能对粮食安全造成影响。平均海平面和极端海平面的上升预计将加剧沿海低洼地区人类社会面临的风险。变暖和极端天气事件也与弧菌引起的某些人类疾病(包括霍乱)风险增加有关。

53. 在海洋科学方面，通过世界气象组织全球大气监测网和全球综合温室气体信息系统及政府间海洋学委员会的海洋碳综合研究工作组等途径，继续并扩大了监测温室气体排放的工作。该委员会收集了与海洋酸化有关的目标14.3.1指标相关的新数据。增进对海洋大气界面的科学认识，包括在联合国海洋科学促进可持续

发展十年<sup>4</sup> 和海洋环境状况(包括社会经济方面问题)全球报告和评估经常程序<sup>5</sup> 框架内这么做, 仍将是一项优先事项。

54. 缓解工作也在继续。在实现国际航运紧急脱碳的宏伟目标方面取得了进展。零排放联盟是在 2019 年气候行动峰会上启动的, 致力于在 2030 年之前让商业上可行的深海零排放船舶投入运营。蓝碳生态系统方面的工作也在继续, 提供了基于自然的解决方案, 通过海洋地球工程缓解气候变化和消除二氧化碳。将沿海生态系统管理计划纳入国家海洋政策有望为缓解和适应活动带来好处。作为重要的碳汇, 有必要针对红树林、海草床、盐沼等海洋生态系统开展进一步养护工作。

55. 在气候行动峰会上作出了承诺, 包括财政认捐, 并启动了适应、复原力和防灾方面的倡议。还采取行动弥补海洋知识方面的差距, 以协助根据《联合国气候变化框架公约》关于气候变化影响、脆弱性和适应的内罗毕工作方案扩大适应工作。联合国贸易和发展会议继续开展主要沿海运输基础设施的适应和复原力建设工作, 特别是在小岛屿发展中国家。目前正在采取行动, 以便更好地应对与气候变化有关的自然灾害, 包括为此实施风险和预警系统、提供技术支持并进行能力建设。

56. 与海洋和气候之间关系有关的问题被加速纳入相关多边海洋和气候变化进程的主流, 联合国气候变化框架公约缔约方会议第二十五届会议对海洋的重点关注突出说明了这一点。缔约方会议要求举行一次关于海洋和气候变化的对话, 并加强缓解和适应行动。将在联合国海洋和海洋法问题不限成员名额非正式协商进程第二十一次会议上审议海平面上升专题。国际法委员会与国际法有关的海平面上升研究组共同主席在第一份问题文件(A/CN.4/740)中也对此进行了审议。

## 八. 在经济增长与环境保护和社会发展之间做到平衡, 以实现可持续的海洋经济并建立复原力

57. 随着各国力图利用海洋和沿海资源及产业的潜力确保经济增长和改善生计, 同时保护海洋健康和生产力, 推行可持续的海洋经济(有时被称为“蓝色经济”) 对各国实现可持续发展依然重要。在这方面, 包含航运、渔业、旅游业和可再生能源在内的全球海洋经济部门的市场价值估计占全球国内生产总值的 5%, 相当于世界第七大经济体。

58. 虽然国家、区域和全球各级继续作出了努力在可持续发展的所有三个层面(经济、社会和环境)进一步推动可持续的海洋经济, 包括通过开发创新的技术、制定法规和金融战略, 但冠状病毒病严重影响了这一进展, 突显了在可持续的海洋经济中建立复原力的重要性, 对最不发达国家和小岛屿发展中国家来说尤其如此。

---

<sup>4</sup> 见 [www.oceandecade.org](http://www.oceandecade.org)。

<sup>5</sup> 见 [www.un.org/regularprocess/content/second-cycle-regular-process](http://www.un.org/regularprocess/content/second-cycle-regular-process)。



59. 冠状病毒病并对实施《2030 年议程》(包括其中与海洋相关的目标和具体目标)产生了重大影响。2019 年 9 月举行的可持续发展目标峰会上认识到, 整个世界未能走上兑现承诺的轨道。秘书长随后启动了“采取行动落实可持续发展十年”, 敦促所有行为体大幅加快实施工作的步伐、扩大实施工作的规模。在应于 2020 年实现的四项与海洋有关的具体目标中, 只有一项关于保护区覆盖面的具体目标(具体目标 14.5)看来有可能实现。此外还有关于其他具体目标方面进展不足的报告。例如, 虽然在实现《2011-2020 年生物多样性战略计划》爱知生物多样性目标 18 方面取得了重大进展, 但该目标的所有方面均得到实现的可能性不大。

60. 必须针对所有具体目标加快行动, 以推动可持续的海洋经济, 增进对海洋的科学认识和了解, 促进海洋科学与技术, 支持养护和可持续地利用海洋生物资源, 保护和保全海洋环境, 养护和可持续地利用海洋生物多样性。实现目标 14 需要国际和跨部门的合作与协调, 包括在落实联合国海洋科学促进可持续发展十年和制定 2020 年后全球生物多样性框架的背景下开展合作与协调。

61. 可持续的海洋经济将继续在冠状病毒病疫情恢复方面发挥关键作用。海事部门为提供基本服务和满足医疗用品、粮食和能源保障等基本需求提供了联系渠道。深海微生物在医疗检测用品盒中的使用彰显了海洋对人类健康的潜力以及海洋生物多样性和生态系统完整性对人类长期福祉的重要经济和社会意义。同时, 经济刺激和恢复工作为更好的恢复提供了机会, 这项工作的重点在于小岛屿发展中国家可持续发展的特情, 其方式是落实有效的海洋治理框架, 纳入基于生态系统的办法、沿海区综合管理、海洋空间规划和生物多样性养护的主流化。

#### A. 增进认识和了解并促进海洋科学与技术

62. 为了增进我们对海洋的了解、制定应对海洋挑战的解决方案, 就需要在各级加大努力, 根据《公约》增加海洋科学研究活动, 并通过自愿技术转让等方式促进和加强相关的能力建设活动。

63. 在海洋科学研究和各国研究能力方面所取得的进展, 包括在观测、数据生成和信息流通方面取得的进展, 有助于增进对海洋生物资源、“区域”、海洋大气界面的科学认识, 包括对气象灾害和海冰变化、海洋酸化、海洋放射性、水深测量和人类对海洋生态系统和生物多样性的影响的科学认识, 并有助于改进海洋预报和相关服务的提供。

64. 2019 年海洋观测会议是全球海洋观测系统未来发展的一个重要里程碑。另外还公布了支持落实全球海洋观测系统 2030 年战略的路线图。海洋信息枢纽项目已经开始执行, 它将有助于通过信息交换中心机制转让海洋技术, 同时, 在开发海洋数据和信息系统来源目录方面业已取得了进展。

65. 可持续发展目标指标 14.3.1 和 14.a.1 落实方法的制定工作取得了重大进展。指标的报告机制包括新建立的海洋酸化数据门户和即将完成的第二版《全球海洋科学报告》。业已采取行动根据可持续发展目标指标 14.1.1 推动制定沿海富营养化指数。同时还在继续努力解决破坏海洋数据浮标的问题。

66. 由于未开展充分的科学政策对话、缺乏数据以及需要共同生成知识、可持续的供资和协调一致地执行《公约》规定的法律制度带来的挑战，在知识和能力方面依然存在重大差距。冠状病毒病产生了重大影响，导致研究工作被取消或推迟，数据流减少，经费也可能减少。政府间海洋学委员会可对第二版《全球海洋科学报告》进行一项补充评估，以评估冠状病毒病对海洋科学的短期影响，并在第三版报告中对长期影响进行更全面的评估。

67. 展望未来，联合国海洋科学促进可持续发展十年将提供一个召开会议的框架，依据“为我们想要的海洋发展我们需要的科学”这一愿景，采取行动应对挑战，并提高海洋科学与技术水平。在利益攸关方通过联合国海洋网络等途径广泛参与下编制的《十年实施计划》将提交大会第七十五届会议。因冠状病毒病而推迟的2020年联合国支持落实可持续发展目标14会议也将提供一次机会，可借以根据该会议的主题扩大促进海洋科学技术的行动。

68. 该十年将使不同的利益攸关方有机会共同设计和开展注重解决方案的研究，需要进行这样的研究来促进海洋的良好运作，以支持《2030年议程》。这将有助于共同开发为决策者、政策制定者、创新者和管理人员所用的各种规模的服务和工具，并激励创新，同时增加获得包括数据和知识平台在内的技术的机会。《实施计划》涵盖了预期成果、在使合作伙伴围绕当下要务联合行动方面面临的一系列挑战以及旨在确定行动框架的一系列目标，同时促进利益攸关方广泛参与网络的形成。

69. 目前正在各级作出努力，通过开展评估等方式加强科学与政策的衔接。作为全球在这方面作出的重大努力，经常程序正在完成其第二次世界海洋评估，且评估已得到各国的同行审议和审查，评估报告将最后定稿，供特设全体工作组审议。经常程序第三周期(2021-2025年)启动后，根据第三周期可能取得的成果和构成要素制定了工作方案草案和所需资源，同时考虑到从第二周期汲取的经验教训，草案和所需资源已得到特设工作组第十二次会议的认可。该草案将由特设工作组审议。

## B. 养护和可持续利用海洋生物资源

70. 2018年全球捕渔业总产量达到有记录以来的最高水平，这一增长的主要驱动因素是海洋捕渔业。处于生物可持续水平上的鱼类种群比例已从1974年的90.0%下降到2017年的65.8%。尽管海洋渔业总体上市量的78.7%来自具有生物可持续性的种群，但渔业管理进展的不均衡突显出迫切需要采取进一步的措施。

71. 在全球、区域和国家各级所采取的行动有助于加强海洋生物资源的养护和可持续利用。粮农组织开展了能力建设和其他活动，涉及的方面包括使国家法律与《公约》统一、粮农组织文书的适用、小规模渔业、性别问题与渔业、渔业统计、渔船海上安全、促进体面工作条件以及参照《2030年议程》的目标和具体目标提出报告。

72. 为了加强渔船的安全并帮助打击非法、未报告和管制外的捕捞活动，有48个国家签署了关于2012年《开普敦协定》的《托雷莫利诺斯宣言》。此外还建议提供指导准则，以协助主管当局执行《开普敦协定》。

73. 冠状病毒病对各区域和各国的海洋生物资源的养护和可持续利用造成了不同影响，包括因取消或推迟渔业方面会议和活动而造成的影响。尽管已经努力以远程方式举行会议，但这种中断对全球许多鱼类种群的养护和管理都可能造成负面影响，包括对监测、控制和监视、渔业研究造成负面影响，也可能造成社会经济影响。

74. 虽然一些区域报告称，非法、未报告和无管制的捕捞活动有所增加，但其他区域则指出，由于旅游业减少，对渔业产品的需求也随之下降。情况在不断变化，而要全面了解冠状病毒病对渔业和水产养殖业的影响，需要在区域和国家两级作进一步的评估。

### C. 保护和保全海洋环境以及养护和可持续利用海洋生物多样性

75. 由于陆上活动构成了 80% 的海洋污染源，目前正在继续合作，通过执行《保护海洋环境免受陆上活动污染全球行动纲领》等方式防止、减少和控制这种污染，特别是海洋废弃物、塑料和塑料微粒。《控制危险废物越境转移及其处置巴塞尔公约修正案》业已生效，明确了所涵盖的塑料废物的范围。巴塞尔公约塑料废物伙伴关系也已经启动。虽然继续开展全球一级的举措来应对海洋废弃物、塑料和塑料微粒，但还需要加大力度，包括解决冠状病毒病的影响。

76. 为了解决造成富营养化的营养盐污染以及缺氧死水区和有害藻华蔓延的问题，作出了特别的努力。发起了联合国全球可持续氮管理运动，同时并通过了《可持续氮管理科伦坡宣言》，为可持续氮管理行动提供了路线图，包括到 2030 年将氮废料减半的远大目标。

77. 此外也已经采取措施防止、减少和控制由汞和放射性物质等危险化学品和废物造成的污染。《巴塞尔公约禁运修正》于 2019 年 12 月 5 日生效，规定禁止该《公约》附件七所列的缔约方越境转移危险废物。

78. 另外并继续进行了合作，以解决航运给海洋环境和海洋生物多样性带来的压力，包括废物倾倒和管理、可持续的拆船、船舶造成的空气污染、压载水管理和生物污损方面的压力。

79. 在政府间一级采取了措施，以应对其他活动对海洋环境的影响，包括近海石油和天然气开采活动和海洋可再生能源的开发，并应对溢油、外来入侵物种、水下噪音、人造光源污染、船只碰撞、兼捕渔获物和水下弹药带来的具体威胁。

80. 海管局继续为“区域”制定采矿法规，并在区域环境管理计划的执行和标准化方面取得了进展。目前正在审查一份关于定于 2021 年进行的预样品结核收集器技术测试的环境影响报告。

81. 关于养护和可持续利用海洋生物多样性，包括在国家管辖范围以外的区域这么做，为确定与海洋有关的要素作出了努力，以便为有关制定《2020 年后全球生物多样性框架》的谈判提供参考资料。各项行动还注重于海洋洄游物种、珊瑚礁、红树林、海草、冷水区和深海生态系统，以及海洋生态系统的恢复，以期为联合国生态系统恢复十年提供参考资料。

82. 《养护野生动物移栖物种公约》缔约方大会第十三次会议通过了一系列关于海洋问题的决议和相关决定，包括加强措施，保护洄游性软骨鱼纲物种，使之不因栖息地的丧失和破坏以及不可持续的渔业等各种构成威胁的进程而受到影响。并通过了人造光源污染准则及海龟和鳗鱼保护措施。该《公约》附录一和附录二增列了若干海洋物种。

83. 相关工作正在继续开展，以支持采取跨部门综合方法应对人类活动对沿海及海洋生态系统的累积影响，包括采取沿海区综合管理、海洋空间规划和生态系统方法。

84. 划区管理工具的确定和适用继续受到了重点关注，包括海洋保护区的指定。截至 2019 年 12 月，国家管辖的海洋区域有 17%属于保护区范围，自 2010 年以来其面积增加了一倍以上。世界上只有大约 7.4%的海洋为保护区所涵盖。许多海洋生物多样性关键地区只部分属于或完全不属于保护区的范围。一些海洋保护区经指定后在实际落实中面临挑战。

## 九. 通过跨部门综合方法加强执行工作

85. 本报告所述期间，冠状病毒病及其相关风险和潜在的长期影响都彰显出迫切需要优先考虑跨部门伙伴关系，确定全球、区域和国家各级信息共享渠道，制定适应性海洋管理战略，促进多方利益攸关方办法，以及在处理与海洋有关的问题方面采取协调一致的行动。

### A. 加强国际合作与协调

86. 本报告所述期间就海洋问题的国际合作与协调实现了一些重要的里程碑，包括通过了审查落实《小岛屿发展中国家快速行动方式(萨摩亚途径)》过程中处理小岛屿发展中国家优先事项方面进展情况高级别会议的政治宣言以及大会主持召开可持续发展高级别政治论坛政治宣言。

87. 尽管因冠状病毒病而推迟或取消了与海洋有关的多边活动和会议，但随着各国、政府间组织和其他利益攸关方利用技术的潜力、创造性应急解决方案和强化的多部门合作(包括通过在线形式)，继续取得了进展。

88. 2020 年首次以在线形式举行的世界海洋日庆祝活动<sup>6</sup>及由《联合国全球契约》举办的可持续海洋业务在线高级别会议为多方利益攸关方对话提供了机会。参与者强调指出，不宜采用分割式部门办法应对海洋挑战。

89. 经济及社会理事会主持的可持续发展高级别政治论坛重点探讨了“加速行动，踏上变革之路：把采取行动落实可持续发展十年变成现实”，并强调需要有更大的抱负，确保对即将到期的可持续发展目标下的具体目标采取持续行动。

---

<sup>6</sup> 见 [www.unworldoceansday.org/2020](http://www.unworldoceansday.org/2020)。

90. 联合国海洋网络举行了电话会议，旨在加强联合国系统各主管组织和海管局的协调、一致性和有效性。联合国海洋网络成员重点强调了会议、讲习班和培训等活动，其中一些活动已转至在线平台。联合国海洋网络成员通过联合国海洋科学促进可持续发展十年联络小组为制定执行计划作出了贡献。

91. 联合国海洋网络成员继续履行其在 2017 年联合国支持落实可持续发展目标 14 会议上作出的自愿承诺，包括在《联合国气候框架公约》缔约方会议第二十五届会议期间组织一次会外活动，以提高对相关监管和政策框架和活动的认识。《生物多样性公约》在其他后续活动中以海洋和沿海生态系统管理海洋行动共同体协调员的身份、与红树林和珊瑚礁海洋行动共同体合作召开了一次会议，推动海洋行动实现目标 14，为此注重利用海洋和沿海生态系统、红树林和珊瑚礁的协同作用。

92. 除了通过联合国海洋网络开展协作外，各组织还分别报告了各自在全球、区域和国家各级为促进就沿海和海洋问题进行跨部门合作和协调而开展的活动。联合国环境规划署的区域海洋方案继续为时下各区域养护和可持续管理海洋和沿海生态系统的工作提供框架。气象组织最近的改组为在海洋问题上开展更密切的合作铺平了道路。它与政府间海洋学委员会在海洋观测方面的伙伴关系经过结构调整，据此成立了世界气象组织-政府间海洋学委员会联合协作理事会。还收到了一些报告，涉及渔业、水下噪音、目标 14 下与贸易有关的方面、空间技术、海洋塑料和塑料微粒、可再生能源、灾害管理和人的方面等领域的合作举措。

## B. 建设各国执行海洋法律和政策框架的能力

93. 许多政府间组织推行了能力建设举措，以协助发展中国家可持续地管理海洋区域、资源和活动，包括为此执行《联合国海洋法公约》和相关文书。虽然许多活动受到冠状病毒病的影响，但这场大流行也说明能力在建立复原力方面具有根本重要性，其中包括恢复能力和其他方面的能力。

94. 海洋事务和海洋法司向各国、政府间组织和其他利益攸关方提供信息、咨询和援助的途径是实施其能力建设方案，包括技术援助项目和研究金以及参加各种大型会议、会议、讲习班和培训活动。<sup>7</sup> 在冠状病毒病疫情中，海法司调整了其能力建设活动，以确保继续向会员国、特别是最不发达国家和小岛屿发展中国家提供切合需要而且能产生效果的援助。

95. 海法司管理 9 个自愿信托基金，以协助发展中国家执行《公约》及其各项执行协议、参加与海洋有关的会议和政府间进程以及经由法庭解决争端。<sup>8</sup>

### 对各国的技术援助

96. 海法司与联合国贸易和发展会议一起实施了一个经联合国发展账户供资的项目，协助巴巴多斯、伯利兹和哥斯达黎加制定论据扎实、政策一致的海洋经济

<sup>7</sup> 更多信息见“海洋事务和海洋法司 2019 年 9 月 1 日至 2020 年 8 月 31 日期间活动一览表”，可查阅：[www.un.org/Depts/los/general\\_assembly/general\\_assembly\\_reports.htm](http://www.un.org/Depts/los/general_assembly/general_assembly_reports.htm)。

<sup>8</sup> 更多信息见“海洋事务和海洋法司管理的自愿信托基金状况(2019 年 8 月 1 日至 2020 年 7 月 31 日)”，可查阅：[www.un.org/Depts/los/general\\_assembly/general\\_assembly\\_reports.htm](http://www.un.org/Depts/los/general_assembly/general_assembly_reports.htm)。

和贸易战略，凭借可持续利用海洋资源实现经济效益。项目活动业已作出了调整，以帮助受益国应对冠状病毒病的影响，促进海洋价值链的恢复，加强海洋治理框架，发展应对今后混乱的能力。

97. 海法司通过一个由支助各国采取举措打击索马里沿海海盗行为信托基金供资的项目向索马里提供援助，使索马里有更强的能力以满足其海事部门和海洋资源可持续发展对能力的需求。然而，旅行方面的限制延迟了计划活动的落实，活动内容将以在线形式提供。

98. 海法司启动了一个由挪威发展合作署资助的项目的执行工作，以协助选定的国家执行《公约》及其执行协议，并促进强化的、可持续的、包容各方的海洋经济，采取的方式中包含了顾及冠状病毒病造成的制约。另一个项目由联合国开发计划署和沙特阿拉伯王国勘测总委员会之间合办的一个现行项目供资，旨在建设勘测总委员会在海洋事务和海洋法方面的能力，关注的重点是海洋边界。

## 研究金

99. 2004 年以来，已向 78 个国家的国民颁发了 165 项联合国-日本财团海洋事务和海洋法特别战略研究金，其中包括在 2020 年颁发的 11 项研究金。2019 年 9 月，在联合国气候峰会召开的同时也举行了校友会。自 2018 年以来已在“联合国-日本财团可持续海洋方案”下颁发了 13 项关键需求研究金，其中包括 2020 年颁发给 5 个人的研究金，而 2015 至 2017 年期间颁发了 3 项战略研究金。2018 年以来已颁发了 35 项主题研究金，其中包括 2020 年颁发的 12 项研究金。2019 年 12 月为 21 名国家代表举办了一项涉及根据《公约》的规定就国家管辖范围以外区域海洋生物多样性的养护和可持续利用问题拟订一份具有法律约束力的国际文书政府间会议的培训，2020 年 3 月也为 21 名国家代表举办了这一培训。1986 年以来，已颁发 35 项汉密尔顿·谢利·阿梅拉辛格海洋法纪念研究金，其中 1 项是在 2020 年颁发的。

100. 虽然已经颁发了 2020 年联合国-日本财团研究金和汉密尔顿·谢利·阿梅拉辛格研究金，但研究金方案的执行因冠状病毒病及因此实施的普遍旅行限制而中断。联合国-日本财团研究金、汉密尔顿·谢利·阿梅拉辛格研究金、关键需求研究金和主题研究金等所有面对面方案都被推迟到 2021 年。原计划与 2020 年联合国支持落实可持续发展目标 14 会议同时举行的联合国-日本财团研究金校友会会议同样已被推迟。2020 年，海法司在联合国-日本财团方案的主持下制定并实施了一项向所有校友和研究人员开放的内容丰富的在线培训课程方案。一些活动也向更大范围的海洋专业人员开放。

## 十. 结论

101. 冠状病毒病对海洋经济部门造成了严重影响。由此对海洋物种造成额外压力，管理和数据收集工作中断，废物增加，进而可能导致对健康和环境造成进一步负面影响。

102. 对于依赖海洋和海洋资源维生的人们来说，冠状病毒病加剧了原已存在的脆弱状况，并带来了新的困苦，包括粮食不安全、个人健康和安全风险、失业以及更广泛的社会和经济混乱。冠状病毒病疫情和相关应对措施对海员和海上移民的影响尤其严重，他们中的许多人本已处于非常危险的境地，而妇女和女童的处境尤其岌岌可危。

103. 应对冠状病毒病大流行的必要性为国际社会提供了一个以更坚韧和更可持续的方式进行重建的机会。应对措施需要能解决紧迫的需求，但也应能预见向以人为本、促进性别平等、包容和可持续的未来进行过渡。在落实《2030 年议程》的同时，扶持可持续的海洋经济为推进各国可持续发展提供了重要机遇，对最不发达国家和小岛屿发展中国家而言尤为如此。

104. 《公约》在公平和有效利用海洋资源、养护海洋生物资源以及保护和保全海洋环境这几个方面之间达到审慎的平衡，由此反映了可持续发展的三个层面。全面和有效地执行《公约》并在同时执行有关海洋的其他法律和政策文书将具有重要意义，并将在涉及面更广的行动中发挥关键作用，以确保海洋和海洋资源得到养护和可持续利用，并确保所有人拥有可持续未来。

105. 继续加强国际合作与协调也至关重要，特别是对帮助最不发达国家、小岛屿发展中国家和沿海社区针对冠状病毒病的冲击开展重建和恢复工作至关重要。将需要在《萨摩亚途径》的实工作所取得进展的基础上再接再厉，包括在联合国海洋科学促进可持续发展十年框架下这么做。此外，加强能力建设举措和转让海洋技术将对恢复工作和建立复原力具有至关重要的意义，特别是对于小岛屿发展中国家和其他低洼沿海发展中国家和社区而言。

106. 对所有与海洋有关的问题采取协调和综合的办法，解决海洋健康状况变差的问题，将依然是当务之急。采取紧急行动的必要性从来没有如同目前这样迫切。这场大流行病突出表明，需要探索创造性和创新性的解决办法，充分发挥多部门协作行动的潜力，改善海洋治理，建立海洋和海洋资源可持续发展所需的管理框架。

107. 政府间气候变化专门委员会 2019 年《关于气候变化中的海洋和冰冻圈的特别报告》概述了全球变暖、海洋酸化、海洋脱氧、海平面上升和极端天气事件对沿海社区以及海洋和沿海生态系统造成的实际和预期破坏性影响，这些影响突出表明需要采取紧急行动来缓解和适应气候变化。由于这一威胁的规模和紧迫性，要求国际社会大力扩大和持续采取行动，包括在冠状病毒病疫情恢复的背景下采取行动。

108. 虽然在国家、区域和全球各级采取了广泛的行动以保护和保全海洋环境，但仍然需要采取紧急行动来应对海洋环境和海洋生物多样性面临的多重、累积的压力，行动方式包括加强监管框架、履行现有义务和承诺以及加强跨部门合作。

109. 必须利用所有可用的资源以恢复和保护海洋的健康、复原力和生产力。其他的问题包括，世界上以可持续方式捕捞的鱼类种群比例持续下降，可见如果要实现制止过度捕捞的目标，就需要共同努力，包括加强渔业管理、恢复枯竭种群和打击非法、未报告和无管制的捕捞活动。

110. 为了支持恢复和实现可持续海洋经济的努力，国际社会必须扩大促进海洋科学与技术的行动，并加强科学与政策的衔接，包括通过联合国海洋科学促进可持续发展十年和经常程序第三周期扩大这些行动。

---



# 船舶船员新冠肺炎疫情防控操作指南（V3.0）

## 目 录

一、建立健全疫情防控管理制度.....	5
（一）制定疫情防控管理计划.....	5
（二）落实疫情防控管理责任.....	5
（三）建立疫情防控排查制度.....	6
（四）建立疫情防控培训制度.....	6
（五）建立疫情防控演练制度.....	6
（六）建立船员换班操作制度.....	7
（七）建立防疫物资保障制度.....	7
二、船舶落实疫情防控措施 .....	7
（一）防疫物资配发使用.....	8
（二）疑似症状监测.....	8
（三）船舶梯口管控.....	8
（四）船岸人员交流.....	9
（五）船舶饮食安全.....	9
（六）船舶舱室通风.....	10
（七）船舶清洁消毒.....	11

(八) 船员换班操作.....	11
(九) 境外疫情防范.....	12
(十) 客运船舶分区分级防控.....	14
<b>三、加强船员个人防护.....</b>	<b>15</b>
(一) 注意个人卫生.....	15
(二) 推荐洗手方法.....	15
(三) 增强防范意识.....	16
(四) 加强自我防护.....	16
(五) 医用口罩选择.....	17
(六) 正确佩戴口罩.....	18
(七) 废弃口罩处理.....	19
<b>四、发现疑似病员应急操作.....</b>	<b>20</b>
(一) 船舶靠泊期间.....	20
(二) 船舶在航期间.....	20
(三) 货船应急操作.....	21
(四) 客船应急操作.....	21
(五) 疑似病员信息沟通.....	22
(六) 疑似病员隔离看护.....	22
(七) 密切接触人员管理.....	23
(八) 疑似病员转移.....	23

(九) 医疗废弃物处置.....	24
五、疑似病例报告.....	24
(一) 船舶报告时机.....	24
(二) 船舶报告事项.....	24
六、疫情常态化防控.....	25
(一) 国内航行船舶操作.....	25
(二) 国际航行船舶操作.....	26
七、船员心理健康调节.....	26
(一) 船员换班困难情况下的心理干预.....	26
(二) 个人心理健康调节推荐方法.....	29
八、疫情信息查询.....	30
附件：客运船舶新冠肺炎疫情分区分级防控建议.....	31

# 船舶船员新冠肺炎疫情防控操作指南（V3.0）

本指南参考世界卫生组织和国际海事组织关于船舶防控新冠肺炎疫情的相关指南文件，结合航运公司关于船舶疫情防控的实践经验，坚持以防为主、及时发现、快速处置、精准管控、有效救治的原则，旨在为船舶防控新冠肺炎疫情提供建议，为船员个人防护提供指导。

中华人民共和国海事局将根据需要更新本指南。

## 一、建立健全疫情防控管理制度

航运公司应当落实主体责任，执行防控规定，建立健全防控工作责任制和管理制度，制定完善应急预案，并根据管理船舶的种类、航行的区域以及疫情分区分级管控的要求，考虑将疫情防控制度纳入公司安全管理体系。

### （一）制定疫情防控管理计划。

航运公司应当建立船舶防控新冠肺炎疫情管理计划，包括船上隔离计划，指导船舶成立疫情防控工作组，由船长担任组长、船上部门负责人担任组员，完善各项疫情防控工作制度，监督船上所有人员落实各项防控措施。

### （二）落实疫情防控管理责任。

航运公司应当确保公司岸基与船舶的沟通联系，指定船长或其他合适的人员作为船舶疫情防控工作的第一责任人，指导船舶开展疫情防控工作，落实各项防控措施，全面加强疫情防控工作。

### （三）建立疫情防控排查制度。

航运公司应当指导船舶建立“防疫工作日志”，排查船上的所有船员，掌握在上船前曾途经存在新冠肺炎疫情的国家或重点地区的船员名单，对疫情排查工作和日常防控工作进行记录和报告。

### （四）建立疫情防控培训制度。

航运公司应当及时向船上提供相关疫情防控的知识培训，制定培训计划，指导船员识别新冠肺炎症状，及时通报疫情防控的相关情况，保证新上船船员在开航前完成疫情防控知识培训，并有计划地定期组织全船船员开展熟悉个人防护用品使用和应急演练程序等方面的培训；对相关船员开展关于疑似病员的船上隔离看护、密切接触人员管理、疑似病员的转移以及乘客的疏导和控制等方面的培训。航运公司培训可采用图文、网络或视频等方式进行远程培训，船上自行组织的培训可采用收看视频、阅读相关资料、船上广播等方式开展。

### （五）建立疫情防控演练制度。

航运公司应当指导船长定期组织船员做好模拟疫情发生时的应急演练，包括与公司岸基的联系、疑似病员的船上隔离看护、密切接触人员管理、疑似病员的转移以及乘客的疏导和控制等。

#### （六）建立船员换班操作制度。

航运公司应当明确与船员派出机构的船员换班管理责任，制定船员换班工作计划，明确船员换班过程中的疫情防控工作要求并有效落实，掌握拟安排船员换班港口的疫情状况和防疫要求，以及船舶上一挂靠港的疫情状况，实施船员换班风险评估，最大可能降低疫情传播风险；指定专班专人负责，指导船舶安全、稳妥地开展船员换班；妥善安排船员换班所必需的防护和生活保障物资，配合船员换班地疫情防控部门落实船员转运、治疗、隔离、留观等防控措施，实现闭环运作；加强与船舶计划靠泊港口口岸部门的沟通联系，及时解决船舶、船员疫情防控中遇到的问题。

#### （七）建立防疫物资保障制度。

航运公司应当及时了解船上防疫实际需求，建立船舶防疫物资供应清单，及时为船舶提供必需的防疫物资；根据国家关于新冠肺炎诊疗方案最新版，为船舶提供相应的预防和治疗药品。

## 二、船舶落实疫情防控措施

### （一）防疫物资配发使用。

1.根据在船船员人数，配发充足的口罩，包括配备给梯口值班人员、与外来人员接触的工作场所人员和航运公司上船工作的岸基人员使用（按船上实际需要配发）；

2.配备防护手套、护目镜和防护服（按船上实际需要配发）；

3.配备医用红外线测温仪；

4.配备手消毒剂，放置在梯口、生活区公共场所使用；

5.配备消毒液、消毒粉用于厨房和生活区场所消毒；

6.船上防疫物资缺乏或不足时，及时向航运公司报告。

### （二）疑似症状监测。

1.船长应当指定专人负责对在船船员和乘客进行体温测量；

2.每天早晚各进行一次体温测量，同时观察和询问有无相关症状，测量结果及疑似症状应当及时登记，由船长签字后存档备查；

3.在船船员和乘客体温跟踪测量实行报告制度，正常情况下每天定时向航运公司岸基管理部门报告，如发现船员发热、疑似病症或身体其他异常情况，应当立即向航运公司报告。

### （三）船舶梯口管控。

1.船舶靠泊作业期间，船长应当督促梯口值班人员加强梯口管控，严格检查所有登轮人员证件及个人防护用品的佩戴情况，

无关人员禁止登轮；

2.梯口值班设置登轮人员体温测量和登记岗，对登轮人员须先测量体温，体温超过摄氏37.3度以及未按规定佩戴个人防护用品的人员禁止登轮；

3.梯口值班人员应当严格佩戴口罩和防护手套，必要时穿戴防护服、佩戴护目镜；

4.在境内高风险地区，无特殊情况不建议船员登陆；

5.登陆人员佩戴过的口罩严禁带入生活区，应当统一投放到梯口设置的密封回收容器中。

#### （四）船岸人员交流。

1.船舶在疫情防控期间应当尽量减少船岸人员的交流活动，谢绝登轮参观访问和家属探望；

2.船舶应当严格控制登轮外来人员的活动区域，在主甲板设立理货间或接待室，限制代理、理货、供应商等外来人员进入船员生活区域。

#### （五）船舶饮食安全。

1.船舶伙食应当从正规供应商处采购，尽可能避免从发生疫情的港口和地区购买，同时做好船舶伙食采购登记；

2.疫情防控期间应当科学制定船上食谱，多补充新鲜蔬菜水果，并适量保证肉、禽、鱼等蛋白质食物的摄入；



3.生食和熟食的砧板和刀具要分开，不吃生食品，尤其是肉类、蛋类和海鲜类；

4.严格落实分餐制度，所有餐具要坚持用餐前消毒。

#### （六）船舶舱室通风。

1.建议船舶起居舱室和生活处所每日通风3次，每次20-30分钟，寒冷地区通风时注意保暖，在高温环境下可增加使用电风扇增强通风和降温；

2.抵达疫区港口的船舶，应当注意船舶空调及通风控制，尽量保持船上生活和居住处所空气新鲜。建议控制船上一次风（新风）占10%-20%，二次风（循环风）占80%-90%，根据船舶实际进行风比调整，直至二次风关闭；

3.中央空调系统风机盘管正常使用时，定期对送风口和回风口进行消毒；

4.中央空调新风系统正常使用时，若出现疫情，不要停止风机运行，应在人员撤离后，对排风支管封闭，运行一段时间后关断新风排风系统，同时进行消毒；

5.带回风的全空气系统，应把回风完全封闭，保证系统全新风运行；

6.船上应当设置隔离处所或隔离区，以防病毒扩散传染。有条件的船舶，隔离处所应当配有独立的卫生间，独立通风或关闭

全船回风，减少生活区内部空气循环。

### （七）船舶清洁消毒。

1.科学使用消毒物品，遵守消毒液、酒精等浓度配比要求，落实防火、防静电等措施，严防发生爆燃、火灾、人员中毒等事故，消毒方法参照国家有关要求和指南进行；

2.加强消毒物资管理，落实专人保管、专室存放、专业操作等制度，减少安全隐患，防止发生安全事故；

3.被确诊为新冠肺炎患者、疑似病员以及与之密切接触人员所使用过的医疗设施、起居舱室和活动处所应每天按照规定的程序进行清洁和消毒。

### （八）船员换班操作。

1.国内航行船舶应当尽可能在中风险、低风险地区开展船员换班，高风险地区港口一般不进行船员换班；国际航行船舶应当根据境内、境外疫情情况，科学合理地确定换班的港口；船员换班应当按照换班地的要求，采取相应的防控措施；

2.船员换班全过程应当做好个人防护设备佩戴、体温检测等措施，如出现健康异常状况的，应当立即暂停船员换班，并按照疫情防控要求进行处理；

3.船员换班上船前 14 天应当保持健康状况正常，每天不少于两次检测体温，填写健康记录并签字，并经航运公司或海员外

派机构确认；符合健康要求的船员应当尽可能从居住地采用“点对点”运输方式前往港口直接换班上船；

4.拟换班离船的船员在船期间应当每天不少于两次检测体温，填写船上隔离健康记录，并经船长签字确认；拟进入境内港口作业的国际航行船舶应当在预计抵达港口 48 小时前向海事管理机构报告在船船员健康信息，航行时间不足 48 小时的应当在驶离上一港口时立即报告；

5.换班船员按规定需进行隔离观察的，应当严格遵守相关隔离要求，自隔离之日起至隔离结束之日止每天向航运公司或海员外派机构报告健康情况；

6.新换班上船的船员应当在最初的 14 天内，尽可能做到上船后的自我隔离，严格遵守船上各项相关防控要求：尽量避免与船上任何身体不适或有感冒或类似流感症状的人员接触，避免与其他船员或乘客进行非必要的接触，与船上其他船员一起工作时，应当保持 1 米以上的社交距离；如有可能，在保证安全的前提下，尽量使用外部楼梯、逃生通道或走道；尽量避免使用船上任何公用场所，例如餐厅、活动室、洗衣间或娱乐场所；在工作时间或任务完成后应当尽快返回其个人起居舱室，尽量在其个人舱室内用餐。

#### （九）境外疫情防范。

1.船舶在境外港口靠泊作业的，应当根据航运公司提供的境外疫情和相关港口的信息以及防控要求，制定相应防控措施，遵守靠泊港口所在地对于船舶货物作业、船舶修理、船舶补给和船员登陆等的规定；

2.船舶在抵达国外港口检疫锚地后，应当立即通过船舶代理通知拟靠泊港口检疫部门，在检疫未完成前，禁止其他人员上下船；

3.船舶应当提前做好靠泊申报工作，保持通讯畅通，按拟靠泊港口检疫部门的要求准备好相关文件材料，例如船员健康情况调查表、船舶卫生情况报告、航海日志、船员和旅客名单、船上医疗记录等，并按照港口检疫部门的要求配合接受检查；

4.船上人员出现发烧、咳嗽、腹泻、虚弱、呼吸困难等症状的，船长应当第一时间向公司报告，并及时向港口检疫部门报告，在其指导下采取积极的防控措施，减少疫情在船上传播的风险；

5.在港口检疫部门发现船上有确诊病例、疑似病员、密切接触者、有发热或有呼吸道症状者，船舶可能会被视为受感染船舶的情况下，船舶应当积极配合港口检疫部门的工作；

6.船舶在境外疫情严重国家或地区的港口靠泊时，船员应当做好在船自我防护，尽可能避免与岸上人员直接接触；因工作需

要确需接触的，应尽量选择在室外空间进行；除对伤病船员实施紧急救助和生产必需外，不安排船员上岸活动；

7.船舶在境外疫情严重国家或地区的港口装卸货作业时，应当通过船舶代理提前与港口方面沟通作业方式和防控措施；应当尽最大可能避免或减少码头作业人员的上船数量，并严格控制其活动区域，人员离船后要加强消杀工作；对于职业暴露风险高的甲板部船员，确有必要与岸上人员发生接触时，应当严格按照要求做好个人防护，佩戴口罩和防护手套，必要时穿戴防护服、佩戴护目镜，保持1米以上的社交距离；码头作业人员上船工作时如缺乏口罩等个人防护用品，船舶应当在确保满足自身防护需要的前提下，尽可能为其提供；

8.船舶应当为引航员等必须登轮且需进入船舶驾驶室等进行室内活动的人员提供必要的防护手套、口罩等个人防护装备；同时，需要与此类人员接触的船员应当做好自身防护工作，待人员离船后应当对其活动区域进行有效的消杀处理。

#### （十）客运船舶分区分级防控。

客运船舶还应当按照本指南附件关于分区分级防控的建议，落实各项防控措施，做好登轮人员的排查，强化船员对疫情防控知识的培训和相关演练，合理安排乘客舱室，保证船舶舱室的消毒和通风，做好船员和乘客的个人防护，控制船岸人

员的交流，加强对船上乘客相关卫生知识的宣传，切实保障船员和乘客的健康安全，防范疫情传播。

### 三、加强船员个人防护

#### （一）注意个人卫生。

1. 船员应当勤洗手、勤洗澡、勤换衣物；
2. 船员在咳嗽或打喷嚏后、在制备食品全过程、在饭前便后、在接触他人或动物后以及外出回船后等情况下，应当规范地清洗手部，无法获得流动水的情况下可采用手消毒剂清洁手部；
3. 船员应当将在室外或工作场所工作时穿着的衣服放在更衣室内，严禁穿回个人房间，勤用消毒液泡洗工作服；
4. 船员在咳嗽或打喷嚏时应当使用纸巾遮挡，防止飞沫喷溅，用过的纸巾建议集中焚烧处理。

#### （二）推荐洗手方法。

使用肥皂或洗手液并用流动水洗手，推荐以下洗手六步法：

1. 双手手心相互搓洗（双手合十搓五下）；
2. 双手交叉搓洗手指缝（手心对手背，双手交叉相叠，左右手交换各搓洗五下）；
3. 手心对手心搓洗手指缝（手心相对十指交错，搓洗五下）；
4. 指尖搓洗手心，左右手相同（指尖放于手心相互搓洗搓五下）；

5. 一只手握住另一只手的拇指搓洗，左右手相同，各搓五下；
6. 弯曲手指使关节在另一手掌心旋转揉搓，交换进行各搓五下。

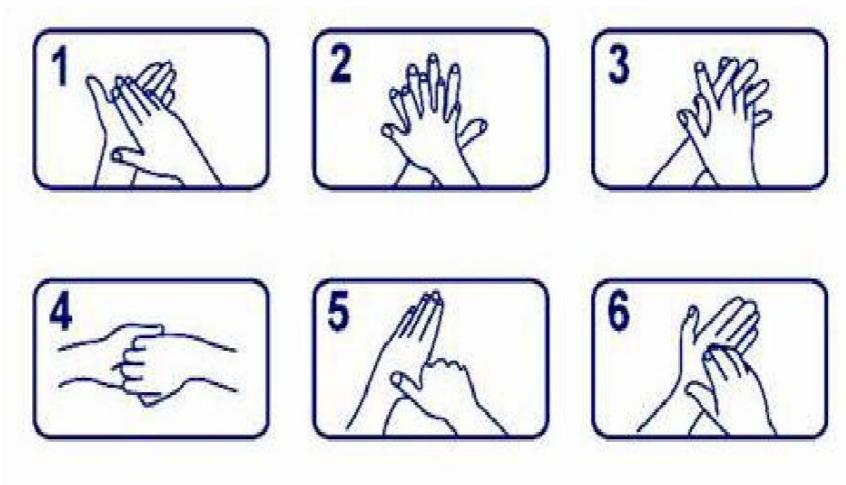

### （三）增强防范意识。

1. 疫情防控期间，尽量减少船上人员之间日常交往，避免与外来人员不必要的接触，交流时保持1米以上的社交距离；
2. 所有外来人员包括引航员登轮后均应当全程佩戴口罩；
3. 外来人员离船后应当对其活动的场所进行通风和消毒；
4. 船员在日常工作中接触外来文件、单据以及其他物品时，应当佩戴口罩和防护手套，必要时应进行消毒处理。

### （四）加强自我防护。

1. 规范佩戴个人防护用品，夏季或高温环境下人员穿着防护服工作应当注意尽可能进行人员轮换，并及时补充体内水分，

避免中暑；

2.靠泊期间，船员离开生活区到甲板工作场所时应当全程佩戴口罩和防护手套，避免与任何有感冒或类似流感症状的人员密切接触，尽量避免登陆到公共场所以及与牲畜或野生动物接触；

3.保证充足睡眠。睡眠不足对人的大脑神经系统功能有伤害，不仅会造成记忆困难、情绪不稳定、工作效率低下，还会降低身体免疫力；

4.加强体育锻炼。在船上养成自觉锻炼身体的习惯，积极运动，保持合适体重，增强体格抵抗力。

#### （五）医用口罩选择。

能有效预防新冠肺炎的口罩类型有：一次性使用医用口罩、医用外科口罩（包括挂耳式和系带式，常见标准YY0469-2010或YY0469-2011，印在口罩的独立外包装上）、医用防护口罩（如医用GB19083-2020、KN95、医用N95-3M1860/1870+、FFP2-UVEX）等。

- 1.一次性使用医用口罩推荐在非人员密集的公共场所使用；
- 2.医用外科口罩推荐疑似病员和与之接触频繁的船上工作人员在岗期间佩戴；
- 3.医用KN95/N95及以上颗粒防护口罩防护效果优于医用外



科口罩、一次性使用医用口罩，主要供医务人员使用，船员在人员高度密集场所或密闭公共场所也可佩戴；

4. 医用防护口罩推荐确诊患者转移时佩戴。



挂耳式医用外科口罩



系带式医用外科口罩



医用防护口罩

#### (六) 正确佩戴口罩。

应当根据不同的操作要求选用不同类型的口罩，佩戴口罩前应洗手或用手消毒剂消毒双手，检查口罩的有效性、完整性等，无异常方可使用。

1. 进入船上人员密集或密闭公共场所须佩戴口罩；
2. 有船上人员疑似感染的，应当佩戴医用防护口罩或医用外科口罩，一次性口罩启用后4小时更换，遇破损、潮湿或受到患者血液、体液污染后，应当及时更换；
3. 有呼吸道基础疾病的人员需在医生指导下使用防护口罩；
4. 以医用外科口罩的佩戴为例，按照下述步骤佩戴：
  - (1) 平展口罩，深色朝外，金属条鼻夹朝上；
  - (2) 将口罩罩住鼻、口及下巴，挂耳式应将两侧耳带挂在双耳上；系带式应将口罩下方带系于颈后，上方带系于头顶中

部；

(3) 将双手指尖放在鼻夹上，从中间位置开始，用手指向内按压，并逐步向两侧移动，根据鼻梁形状塑造鼻夹；

(4) 系带式可调整系带的松紧度。

#### 5.摘脱口罩的步骤：

(1) 不要接触口罩的前面（污染面）；

(2) 挂耳式医用外科口罩：双手提起两侧耳带；

(3) 系带式医用外科口罩：先解开下面的系带，再解开上面的系带；

(4) 医用防护口罩：将颈部的下头带从脑后拉过头顶，拉上头带摘除口罩；

(5) 用手仅捏住口罩的系带丢弃。

(七) 废弃口罩处理。

1.船上使用后的废弃口罩应当分类处理；

2.健康船员佩戴过的口罩，一般在口罩变形、弄湿或弄脏导致防护性能降低时更换，使用后的口罩，可按照生活垃圾分类的要求处理；

3.疑似病员、确诊患者、呼吸道疾病患者或密切接触人员佩戴的口罩，不可随意丢弃，应视作医疗废弃物，统一存放至黄色感染性医疗废物垃圾桶，并建议使用含氯5%的消毒液按照

1:99配比后，撒至口罩上进行处理，且每天两次使用75%酒精或含氯消毒剂对垃圾桶进行消毒处理。

#### 四、发现疑似病员应急操作

船上发现疑似病员情况时，应当按照船舶疫情防控管理计划的要求启动应急操作程序，落实人员隔离和防护的各项措施。

##### （一）船舶靠泊期间。

- 1.立即对疑似病员实施隔离，全船人员做好防护措施；
- 2.向航运公司和当地疫情防控部门报告，接受远程医疗指导；
- 3.联系当地代理或航运公司代表安排疑似病员离船就诊，同时通知航运公司给予相关岸基支持，在船船员尽量不参与疑似病员的移动和运输；
- 4.疑似病员送岸检查确诊后，同时排查隔离密切接触者；
- 5.全船做好消毒工作，对疑似病员起居舱室和活动处所进行重点消毒；
- 6.对疑似病员密切接触人员实施隔离观察；
- 7.保证足够的值班船员，人员不足时，应当及时妥善地安排船员换班上船，以确保船舶安全。

##### （二）船舶在航期间。

- 1.立即对疑似病员实施隔离，全船人员做好防护措施；

2.向航运公司报告,需要时向离岸最近的疫情防控部门请求远程医疗救助,接受远程医疗指导;

3.岸基和船舶共同评估疑似病员病情,如病情可控,可等船舶抵港后安排到当地医院检查、治疗;如病情不可控,航运公司应当立即启动应急响应,岸基和船舶商定紧急靠岸或送岸方案,以最快速度将疑似病员送岸检查、治疗;

4.启动应急换班操作并对疑似病员密切接触人员实施隔离观察;

5.全船做好消毒工作,对疑似病员起居舱室和活动处所进行重点消毒。

### (三) 货船应急操作。

1.关闭船舶空调系统;

2.关闭船员房间和公共场所布风器,阻断船员房间之间的内部空气流通;

3.将疑似病员安置在医务室或独立的舱室进行隔离,采用自然通风;

4.疑似病员应当尽可能安置在同一区域,单间隔离,并实施封闭管理。

### (四) 客船应急操作。

1.将疑似病员隔离于有舷窗的房间,关闭布风器,阻断与其

他房间的内部空气流通，采用自然通风；

2.关闭公共场所布风器和回风，有舷窗的房间也关闭布风器，采用自然通风；

3.空调系统只向没有舷窗的房间供风，并应调整至新风模式；

4.关闭回风防止病毒携带者对其他人员构成威胁；

5.有条件的可在空调房安装紫外线消毒器，根据紫外线消毒器消毒时长要求，完成消毒后短暂启动空调，实行间歇供风，保证没有舷窗的房间有足够的氧气含量。

#### （五）疑似病员信息沟通。

船上应当使用船舶广播系统和对讲机与疑似病员进行信息沟通，减少人员直接接触。食品供应等事项应当约定错开接触物品的时间，降低交叉感染的可能性。

#### （六）疑似病员隔离看护。

1.疑似病员应佩戴医用外科口罩，并在单独的舱室进行隔离，不参与船上群体性活动，在隔离舱室单独用餐，避免与其他人员直接接触；

2.隔离舱室应加强空气流通，或持续使用排气扇保持空气流通，注意环境清洁；

3.疑似病员使用过的防护手套、纸巾、口罩以及其他废弃物

都应当放在专用的垃圾袋封存，并标记为污染物；

4.限制看护人数，尽量安排健康状况良好且没有慢性疾病的人员进行护理，看护期间应当佩戴好口罩、防护手套、护目镜，必要时应穿着防护服，并拒绝一切探访，防护用品使用后应当作消毒或废弃处置。

#### （七）密切接触人员管理。

船舶应当评估所有人员与疑似病员的接触情况，收集船员/乘客活动位置表，并将其归类为高风险接触者（密切接触者）和低风险接触者。对接触人员的追踪应当在船上发现疑似病例后立即开展，所有可能与疑似病员有过密切接触的乘客、医护人员和船员应当在船上医疗人员或专业医护人员的指导下进行隔离，隔离期限从最后一次与疑似病员可能有接触之日起算14天。

#### （八）疑似病员转移。

在疑似病员下船期间，应当尽量减少与船上其他人员的接触，严格控制疑似病员在船上活动的区域。

疑似病员的转移原则上应当由岸上专业的医护人员实施。如因条件限制，确需船员参与疑似病员转移的，相关船员应按规定进行手部卫生处理，并按规定佩戴医用口罩、护目镜、防护服和防护手套。

### （九）医疗废弃物处置。

船舱或隔离处所内所有的废弃物须按照船舶医疗废物进行处理。如果废弃物可在船上焚烧，须进行焚烧；如果须送岸回收，应当提前通知港口当局并按要求采取特殊的防护措施。

## 五、疑似病例报告

### （一）船舶报告时机。

当船上发生船员或乘客出现发烧、咳嗽或呼吸困难症状并且在过去14天内去过发生疫情的地区，甚至导致死亡时，应当立即向港口所在地或者离岸最近的卫生健康部门或检验检疫部门报告，并通报海事管理部门。

### （二）船舶报告事项。

- 1.船舶名称、船舶类型、船旗国、船籍港、国际海事组织编号或船舶呼号，在船船员及乘客人数；
- 2.最近14天内船舶停靠港，包括疑似病员下过船的停靠港清单；
- 3.疫情发生的日期、时间和船舶地理位置；
- 4.相关疑似病员的姓名、性别、职务、出生日期、国籍和登船日期；
- 5.相关疑似病员的体温记录、症状和体征清单（包括各症状显现时间）、死亡人数（如有）、可能发生原因、已采取措施

和发展趋势等。

国际航行的船舶，如果航行时船上发生疑似病例，应当根据《国际卫生条例（2005）》和拟安排疑似病员下船港口所在国家法律要求，向当地主管当局提交《海事健康声明》。

## 六、疫情常态化防控

### （一）国内航行船舶操作。

1.疫情常态化防控形势下，国内航行船舶、船员仍应当按照本指南第二、三、四、五章做好疫情防控工作，其中有关措施也可按下述建议实施：

（1）船舶起居舱室和生活处所每日通风至少1次，每次20-30分钟；

（2）船舶靠泊期间，船员离开生活区到甲板工作场所时可不必要全程佩戴口罩和防护手套；

（3）船舶应当合理安排登轮参观访问和家属探望的人数及频次，对登轮人员做好记录，至少包括时间、使用的交通工具和登轮前行程轨迹，并控制其活动区域；

（4）体温检测正常的船员，在按当地规定做好必要防护情况下，可以正常登陆活动，但应当注意避免长时间在人员聚集场所活动；船舶对上岸活动船员应当做好记录，至少包括时间、地点、使用的交通工具、活动轨迹。



2.如国内航行船舶与国际航行船舶在船-船作业活动时发生人员直接接触，且国际航行船舶过去14天曾停靠过境外疫情严重港口或船上曾发生疫情/出现“四类”人员，则国内航行船舶、船员应当按照本指南第二、三、四、五章做好疫情防控工作。

## （二）国际航行船舶操作。

疫情常态化防控形势下，国际航行船舶（包括内外贸兼营船舶）在境内航行作业期间，船舶、船员仍应当按照本指南第二、三、四、五章做好疫情防控工作；船舶可根据在境外航行的区域和港口疫情情况，动态调整船舶防控响应，实施精准防控，但无论如何，应当确保严格做好防范境外疫情输入工作。

## 七、船员心理健康调节

船长应当组织做好船员的心理疏导和健康调节工作。疫情期间，由于受到岸上疫情和防控措施的影响，可能导致船员正常换班困难，船员因此延长在船工作时间、无法正常上岸休息休假，加之船上信息不畅通，易导致船员心理出现焦虑多疑、惶恐不安、愤怒暴躁、抑郁悲伤、恐惧害怕、盲目乐观、孤独寂寞、冲动激惹等负面情绪，需要针对性及时排解。

### （一）船员换班困难情况下的心理干预。

#### 1.应激反应过度的判断方法。

（1）连续3天或更长时间的睡眠困扰，如入睡困难、多梦、

梦魇、早醒等；有明显的身体不适感，主要表现为身体紧张、不易放松、食欲不振、尿频、尿急、心慌、坐立不安、多汗、怕冷等；

(2) 反复回想与新冠肺炎相关的消息、视频，或脑中不断冒出相关字眼；

(3) 容易受到惊吓，或者不敢看与新冠肺炎疾病相关的信息；

(4) 看到或听到别的船员换班休假的信息，产生烦躁、不安等心理；

(5) 反复回忆起过去某个阶段的痛苦经历；

(6) 明显的情绪不稳定，或紧张恐惧，或悲伤抑郁，或易发脾气；

(7) 出现冲动、攻击性、伤害性的言语或行为。

## 2.认识应激反应过度的危害。

(1) 影响情绪和行为；

(2) 影响认知功能，包括注意力、判断力；

(3) 影响身体健康状况，如原有疾病加重，或诱发高血压、高血糖、痛风、消化系统溃疡等身心疾病；

(4) 影响社会交往、工作状态和家庭关系。

## 3.心理干预。

(1) 鼓励表达和沟通。在船船员遇到困难,难以像在陆上一样向亲人和朋友倾诉,以此释放或舒缓心理压力。因此,鼓励船员表达喜怒哀乐,使自己内心得到放松,船员可积极与关系好的同事交流情绪感受,船上可组织小组交流活动;

(2) 鼓励坚持写日记,记录生活和经历。长时间相对单一的船上生活模式,易使人的思考动力弱化。鼓励船员以日记方式记录日常生活和工作,对情感进行反思和分析,有助于提高观察和体会生活的能力,进而推己及人,增强转移注意力的能力,促进同事间的相互理解。另可给家人写信,虽可能无法寄出,但日后重聚,可以悄悄放在他(她)们枕头下,表达对家人的情感;

(3) 鼓励引导自身正性思维。疫情期间,船员为保障国际物流供应链畅通和重要防疫物资运输发挥了巨大作用,为国家做贡献,为家人保健康,船员应当意识到自己在疫情防控中的责任,提升国家和集体荣誉感、自我价值感、职业自豪感;

(4) 鼓励船上团队心理互助。船上可指定或推举性格外向、心态积极的船员担任团队心理互助组长,鼓励船员及时反映自身出现的应激反应过度和不良情绪,船员之间加强相互支持、鼓励与帮助,倾诉、倾听和交流心理情感问题,缓解波动情绪,进而保持良好的身心状态;

(5) 鼓励音乐、跳舞或体育活动。船上可因地制宜组织集体性的音乐、跳舞或体育活动，尤其是与音乐相关的活动。因船上空间有限、船体摇摆，体育活动的选择要结合实际、注意安全，推荐选择如太极拳、瑜伽、八段锦、五禽戏等健身气功，或者广播体操、健身操、武术等运动，既提高船员情绪，又通过互相配合和频繁互动，丰富船上生活，增进彼此的信任和情谊。

## (二) 个人心理健康调节推荐方法。

### 1. 平缓呼吸法。

吸气、屏气、呼气均默数 5 秒，吸气时通过鼻腔缓慢而充分地将空气吸到身体最深处，呼气时通过鼻腔或口腔缓慢呼出，完全呼出气体后可正常呼吸 2 次。循环上述步骤，每次练习 3 - 5 分钟。

### 2. 肌肉放松法。

可以采用平躺或端坐的姿势，放松顺序可遵循自上而下，从头到脚，反之亦可。

### 3. 蝴蝶拍法。

闭上眼睛或半合眼，双臂交叉放在胸前，双手交替摆动，轻拍双肩，同时缓慢深呼吸，如此重复数次。

### 4. 保险箱封存法。

一种通过想象方法来完成的负面情绪处理技术。有意识地

对内心积攒的负面情绪进行打包封存，从而使自我可以在较短的时间内从负面情绪及消极观念中解放出来。

## 八、疫情信息查询

新冠肺炎最新疫情信息可查询中国疾病预防控制中心官方网站<http://www.chinacdc.cn>，中国地区可拨打健康咨询电话：12320。

附件

## 客运船舶新冠肺炎疫情分区分级防控建议

防护内容		高风险地区	中风险地区	低风险地区
排查	客运船舶 排查所有船员近 14 天旅居地	每次开航前	每次开航前	每次开航前
培训	客运船舶 新上船船员疫情防控知识培训	开航前	开航前	开航后 24 小时内

		全船船员熟悉个人防护用品使用和应急演练程序等方面的培训；相关船员关于疑似病员的船上隔离看护、密切接触人员管理、疑似病员的转移以及乘客的疏导和控制等方面的培训	每周	每周	每月
演练	客运船舶	模拟疫情发生时的应急演练，包括与公司岸基的联系、疑似病员的船上隔离看护、密切接触人员管理、疑似病员的转移以及乘客的疏导和控制等	每周	每周	每月

消毒	客运船舶	座椅、扶手、栏杆、地板、驾驶室、行李架、穿戴过的救生衣、客舱床位、卫生间等	每次开航前	每次开航前	每次开航前
		梯口、生活区等公共场所配备手消毒剂，带有卫生间或者洗手池的处所配备消毒洗手液	配备	配备	配备
		自然通风	风机和通风筒全开	风机和通风筒全开	视天气和温度确定
通风	客运船舶（封闭式）	中央空调系统（内循环）	停用	停用	视情况使用



	客运船舶 (开敞空间设有座椅)		乘客优先安排在开敞空间	乘客优先安排在开敞空间	—
运输	客运船舶	客座率	≤ 50%	≤ 70%	≤ 90%(设置发热乘客隔离区的除外)
		客舱安排	单人单间	≤ 3 人一间	尽可能分散安排
防护	客运船舶	上下旅客安排	分批次上下船, 减少聚集		
		船员和乘客戴口罩	100%佩戴	100%佩戴	—
		船员护目镜、防护手套	100%佩戴防护手套(护目镜视情佩戴)	100%佩戴防护手套(护目镜视情佩戴)	—

船上餐饮、零售和娱乐设施	体温测量时间间隔（国际航线）	码头测量或者登轮前测量合格，开航后早、中、晚各一次	零售设施可用	零售设施可用	零售设施可用	餐饮、零售设施可用
	体温测量时间间隔（国内航程大于2小时）	码头测量或者登轮前测量合格，开航后早晚各一次（夜间），两小时一次（白天）				码头测量或者登轮前测量合格

				码头测量或者登轮前测量合格	码头测量或者登轮前测量合格	码头测量或者登轮前测量合格
		体温测量时间间隔（国内航程小于2小时）	按乘客定额10%安排	按乘客定额10%安排	按乘客定额5%安排	视情况设置
		发热乘客隔离区	100%	100%	100%	100%
		发热乘客信息登记	每航次	每航次	每航次	每航次
		船上垃圾处理	严控登轮，不更换船员	严禁登轮，不更换船员	原则上不更换船员	—
		船员	禁止登轮（紧急情况或必须情况除外）	禁止登轮（紧急情况或必须情况除外）	禁止为船舶提供服务的人员登轮（紧急情况除外）	—
船岸交流		航运公司岸基人员、为船舶提供服务的人员				

宣传	客运船舶	船上要通过广播、视屏等开展卫生防护知识宣传	需要	需要	需要
乡镇客渡船应当根据实际情况尽可能满足上述分区分级防控建议要求。					

## 《海洋法律与政策》稿约

《海洋法律与政策》(Marine Law and Policy), 国际刊号: 2709-3948, 是由海南大学法学院、海南大学国际海洋法与争端解决中心、大连海事大学海法研究院、上海海洋大学海洋文化与法律学院、香港理工大学董浩云国际海事研究中心、澳门大学法学院、台北世新大学法律学院联合主办, 是大海法领域中英双语对照的优秀国际学术期刊。本刊秉承实事求是的精神, 力求刊发海内外与海洋法律、海洋政策相关的一切优秀研究成果, 热忱欢迎广大专家、学者不吝赐稿, 兹立稿约如下:

一、鼓励英文著述, 同一学术水准稿件, 英文著述将优先录用。

二、来稿形式不限, 学术专论、评论、判解研究、译作等均可, 篇幅长短不拘, 不考虑稿件作者的身份和以往学术经历, 只有学术水准和学术规范的要求。

三、来稿须同一语言下未曾在任何纸质和电子媒介上发表。稿件请注明作者姓名、学位、工作单位、职务、职称、研究领域和通讯方式等。来稿必复, 编辑部将在收到来稿后两个月内安排匿名审稿。超过 3 个月未接到录用通知者, 可自做他用。来稿一律不退, 请作者自留底稿。

四、译作请附寄原文, 并附作者或出版者的翻译书面授权许可。译者须保证译本未侵犯作者或出版者的任何权利, 并在可能的损害产生时自行承担损害赔偿责任。《海洋法律与政策》编辑部及其任何成员不承担由此产生的任何责任。

五、欢迎对本刊所刊文章进行转载摘登和结集出版, 但应尊重原作者依照《中华人民共和国著作权法》享有的权利, 并在转载时注明“转自《海洋法律与政策》20xx 年第 x 期”和原作者、译校者姓名, 同时书面通知本刊编辑部。

六、为扩大本刊及作者的知识信息交流渠道, 本刊将陆续加入 Westlaw China、北大法宝、台湾华艺、维普、中国知网、超星法源、读秀、Heinonline 等中外数据库, 除非作者在来稿时特别声明, 否则即视为同意《海洋法律与政策》拥有以非专有方式向第三方授予已刊作品电子出版权、信息网络传播权和数字化汇编、复制权, 以及向《中国社会科学文摘》《高等学校文科学术文摘》和中国人民大学书报复印资料等文摘类刊物推荐转载已刊作品的权利。

七、《海洋法律与政策》实行双向匿名审稿制度。来稿一经刊用, 即从优支付稿酬, 并提供样刊两册, 无需版面费。

八、凡向《海洋法律与政策》编辑部投稿, 即视为接受本稿约。来稿请寄电子邮箱: CISLDS.MLP@hainanu.edu.cn。为了实现办公信息化, 要求作者必须以电子邮件方式投稿, 本刊不再接受纸质投稿。

《海洋法律与政策》编辑部

## **Marine Law and Policy Call For Papers**

Marine Law and Policy [ISSN 2709-3948] is an academic journal focusing on ocean-related laws and policies. This Chinese-English bilingual journal is jointly sponsored by Hainan University Law School Centre for International Sea Law and Disputes Settlement, Dalian Maritime University Institute of Maritime Law and Ocean Law, Shanghai Ocean University Ocean Culture and Law School, Hong Kong Polytechnic University CY Tung International Centre for Maritime Studies, University of Macau Law School, Taipei Shih Hsin University Law School. Papers from all academics and industry practitioners are faithfully respected and welcome. Instructions to contributors are listed as follows:

1. No restrictions are placed on the style, idea, perspective or length of the paper;
2. Potential contributors are expected to provide their personal information, including name, degree, occupation, and contact information;
3. Contributors should strictly follow the format for academic writings;
4. If the submission is a translation from other professionals, the original paper and a written authorization issued by the original author or publisher are also required;
5. Authors are responsible for the content of their contributions, unless otherwise declared; however, the Editorial Board has the discretion to edit the textual details;
6. Submissions are subject to double-blind peer review within two months of submission;
7. Authors of selected papers will be paid in a lump-sum and two free copies of the Journal will be offered to each author;
8. Submission of an article implies that the authors have read, understood and agreed to the above statements.

Authors are kindly requested to submit their papers electronically by emailing to [CISLDS.MLP@hainanu.edu.cn](mailto:CISLDS.MLP@hainanu.edu.cn).

**MLP Editorial1**

# MLP 引注格式

## 引注一般格式:

注释内容采用页下脚注。引注符号使用阿拉伯数字，可以带圆圈或者六角括号，也可以不带。对论文作者的介绍、翻译作品的译者注，可以使用其他符号，以示区别。全篇引注序号为连续编码。

### (一) 引用书籍的基本格式为:

- (1) 王名扬:《美国行政法》，北京大学出版社 2007 年版，第 73-75 页。
- (2) [美]富勒:《法律的道德性》，郑戈译，商务印书馆 2005 年版。

### (二) 引用已刊发文章的基本格式为:

- (1) 季卫东:《法律程序的意义:对中国法制建设的另一种思考》，载《中国社会科学》1993 年第 1 期。

### (三) 引用网络文章的基本格式为:

- (1) 汪波:《哈尔滨市政法机关正对“宝马案”认真调查复查》，载人民网 2004 年 1 月 10 日。  
<http://www.people.com.cn/GB/shehui/1062/2289764.html>。

- (2) 赵耀彤:《一名基层法官眼里好律师的样子》，载微信公众号“中国法律评论”，2018 年 12 月 1 日。

微信公众号的链接过长时，不标注链接。

### (四) 引用学位论文的基本格式为:

- (1) 李松锋:《游走在上帝与凯撒之间:美国宪法第一修正案中的政教关系研究》，中国政法大学 2015 年博士学位论文。

### (五) 引用法律文件的基本格式为:

- (1) 《民法总则》第 27 条第 2 款第 3 项
- (2) 《国务院关于在全国建立农村最低生活保障制度的通知》，国发〔2007〕19 号，2007 年 7 月 11 日发布。

### (六) 引用司法案例的基本格式为:

- (1) 包郑照诉苍南县人民政府强制拆除房屋案，浙江省高级人民法院 (1988) 浙法民上字 7 号民事判决书。
- (2) 陆红霞诉南通市发改委政府信息公开案，《最高人民法院公报》2015 年第 11 期。

### (七) 同一文献多次出现

对同一文献的引用应当适度；同一文献在文中多次出现的，为防止修改、编辑过程中发生错乱，作者投稿时不建议采用略写。

## （八）其他

### [1] 论文摘要

摘要应客观反映文章核心内容，言之有物、连贯顺畅、独立成篇。摘要可以摘录文中字句，但不宜大段重复论文段落。摘要不使用第一人称（如“我认为”），忌带主观评价（如“具有开创意义”）。学术论文的摘要，以 200-300 字为宜，不分段；论文篇幅较长的，摘要字数可以稍多。硕士学位论文的摘要可以稍长，一般不超过 800 字（以一页 A4 纸为宜），建议分段；

### [2] 关键词

学术论文摘要之后，附关键词 3-5 个。关键词栏以“关键词”字样引导，后加冒号。关键词应当标示论文的核心主题因素。不使用过分特别、其他研究者不会想到的语词，也不使用过分普通、没有识别度的语词，作为关键词。关键词一般不带引号、书名号。关键词之间留空格，或者用分号隔开。例如，不写“《行政许可法》”，而直接写：

关键词：行政许可法 行政审批改革 服务行政

### [3] 作者介绍

论文作者介绍，应当标明作者的工作单位和学术头衔（职称、学历）。例如：

林来梵，法学博士，清华大学法学院教授。

作者介绍一般只写最主要身份，不写“博士生导师”“研究会理事”等；除了在职公务人员，不写行政职务。确有必要标明兼职身份的，原则上只写一个。作者学历，一般只写最高学历，可以具体写上学位授予单位。作者介绍可以置于页下脚注位置，用星号标注。

## 外文引注体例

一般规则：引用外文文献，一般不做翻译，直接使用外文；必要时，可加以解释或者评注。英文姓名，名在前、姓在后，首字母大写。例如，William P. Alford。姓在前、名在后、中间加逗号，如“Alford, William P.”，是列举参考文献时的通常写法，不宜用于注释。华人作者的署名，原则上尊重作者在文章中的写法。姓在前、名在后的，姓氏采用大写字母，例如，张力写作 ZHANG Li。

### （一）英文学术期刊

Charles A. Reich, *The New Property*, 73 *Yale Law Journal* 733, 737-738 (1964).

Stephen J. Choi & Adam C. Pritchard, *Behavioral Economics and the SEC*, *Stanford Law Review*, Vol.56:1, p.1-73 (2003).



(二) 英文报纸文章

Andrew Rosenthal, White House Tutors Kremlin in How a Presidency Works, New York Times, June 15, 1990.

(三) 英文书籍

William P. Alford, To Steal a Book is an Elegant Offense: Intellectual Property Law in Chinese Civilization, Stanford University Press, 1995, p.98.

页码为复数的, 也写 p., 不写 pp.。

Jürgen Habermas, Between Facts and Norms: Contribution to a Discourse Theory of Law and Democracy, translated by William Rehg, MIT Press, 1996, p.330-336.

(四) 英文网页

Stephen McDonell, When China Began Streaming Trials Online, BBC NEWS (Sept. 30, 2016), <https://www.bbc.com/news/blogs-china-blog-37515399>.

(五) 其他

英文案例的引用方式, 因不同国家、不同法院、不同案例报告系统而有所区别。基本格式为

Natural Resources Defense Council v. Gorsuch, 685 F.2d 718 (D.C. Cir. 1982); Chevron U.S.A., Inc. v. Natural Resources Defense Council, 467 U.S. 837 (1984).

\*详细可请参考中国法学会法学期刊研究会出版的《法学引注手册 2019》。

## 《海洋法律与政策》订购单

订购人	
邮寄地址	
电子邮件	
联系电话 / 传真	
订购期数	自____年 第____期 至____年 第____期
订购本数	每期____本
合计金额（每本定价人民币 50 元，含邮费）	
备注	

订阅者可通过银行或邮局将订阅款汇至海南大学，有关账户信息如下：

账户名称：海南大学

银行账号：21150001040000040

开户银行：中国农业银行海口海大支行

转账时请留言“订阅《海洋法律与政策》”。转账成功后请将订购期数、邮寄地址、联系人、汇款数额等信息发送至 CISELDS.MLP@hainanu.edu.cn。

### 诚邀赞助

《海洋法律与政策》是大海法领域中英双语对照的优秀国际学术期刊，每年出版 4 期，读者主要包括海内外高校、科研机构以及法院、律所等涉海企事业单位的科研人员和实务工作者。本刊致力于推动中国海洋领域法律与政策的繁荣发展，衷心欢迎关心中国海法发展的各企事业单位提供赞助。有意者请垂询《海洋法律与政策》编辑部（电话：+(86)-898-66165902 或电邮 CISELDS.MLP@hainanu.edu.cn）。

## ***Marine Law and Policy* Subscription Form**

Name of Subscriber	
Name of Contact Person	
Address	
Tel/Fax No.	
E-mail	
Subscription Period	
Amount Payable (USD 40 per copy, including air postage)	
Remarks	

Subscribers may purchase a copy of MLP by e-mailing the Subscription Form to [CISLDS.MLP@hainanu.edu.cn](mailto:CISLDS.MLP@hainanu.edu.cn) and transferring the submission fee to the following bank account:

Account Name: Hainan University

A/C: 21150001040000040

Deposit Bank: Agricultural Bank of China Haikou Branch

Please write “subscription to *Marine Law and Policy*” on the remark column of the remittance slip.

### **Invitation to Sponsor**

*Marine Law and Policy* is a compilation of research focusing on Marine laws and policies. This Chinese-English bilingual journal is jointly sponsored by Hainan University, Dalian Maritime University, Shanghai Ocean University, The Hong Kong Polytechnic University, Macau University and Taipei Shih Hsin University. If you are interested in sponsoring this quarterly journal, please kindly contact MLP Editorial Board (Tel:+(86)-898-66165902 or e-mail us at [CISLDS.MLP@hainanu.edu.cn](mailto:CISLDS.MLP@hainanu.edu.cn) ).

# 海洋法律与政策

## Marine Law and Policy

(季刊)

2021 年 第 1 期 总 第 1 期

刊 号: ISSN 2709-3948

出版时间: 2021 年 1 月

©THE AUTHOR AND MARITIME LAW AND POLICY

主办单位:

海南大学法学院 海南大学国际海洋法与争端解决研究中心

大连海事大学海法研究院

上海海洋大学海洋文化与法律学院

香港理工大学董浩云国际海事研究中心

澳门大学法学院

台北世新大学法律学院

出版单位:《海洋法律与政策》编辑部

印刷单位: (香港) 东美设计印刷有限公司

创刊主编: 傅崐成

共同主编:

赖来焜, 台北世新大学, 台北

韩立新, 大连海事大学, 大连

翁文挺, 澳门大学, 澳门

戴锡崑, 联合国际学院, 珠海

傅崐成, 海南大学, 海口

地 址: 海南省海口市人民大道 58 号海南大学法学院 570228

电 话: + (86) -898-6616 5902

电子信箱: CISLDS.MLP@hainanu.edu.cn

发行单位:《海洋法律与政策》编辑部

国内定价: 人民币 50 元

国外定价: 美元 40 元

# Marine Law and Policy

(Quarterly)

**Volume 2021 Number 1**

**ISSN :** 2709-3948

**Publication:** January 2021

©THE AUTHOR AND MARITIME LAW AND POLICY

## **Sponsors:**

Hainan University Law School

Hainan University Centre for International Sea Law and Disputes Settlement

Dalian Maritime University Institute of Maritime Law and Ocean Law

Shanghai Ocean University Ocean Culture and Law School

Hong Kong Polytechnic University CY Tung International Centre for Maritime Studies

University of Macau Law School

Taipei Shih Hsin University Law School

**Publisher:** Editorial Board of *Marine Law and Policy*

**Printing House:** (HK) TUNG MEI design & printing LTD.

**Founding Editor-in-Chief:** FU Kuen-chen

## **Co-Editor-in-Chief**

LAI Laikun, Shih Hsin University, Taipei

HAN Lixin, Dalian Maritime University, Dalian

WENG Wenting, University of Macau, Macau

TAI Sik Kwan, United International College, Zhuhai

FU Kuen-chen, Hainan University, Haikou

## **Address:**

Hainan University Law School, 58 Renmin Ave., Haikou, Hainan 570228, CHINA

**Tel:** + (86)-898-6616 5902

**E-mail:** CISLDS.MLP@hainanu.edu.cn

**Distributor:** Editorial Board of *Marine Law and Policy*

**Price:** (RMB) ¥50

(USD) \$ 40