

# Hudson Tipper Wagon Kit

Made in the UK by Peter Binnie, Coed Dyfi, Pennal, Machynlleth, SY20 9LB  
peterbinnie.com

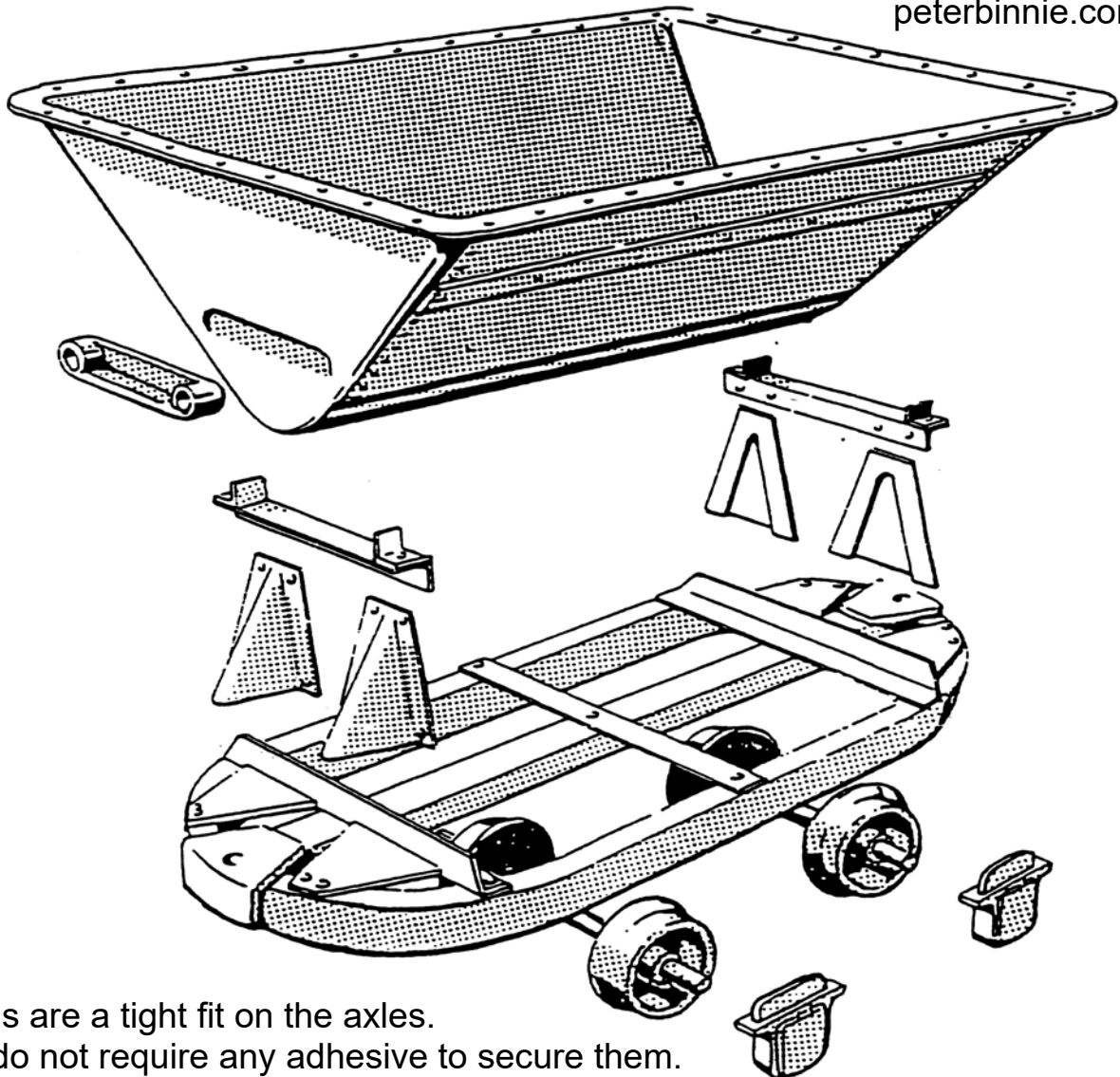

Wheels are a tight fit on the axles.

They do not require any adhesive to secure them.

For 45mm gauge (G) wheels should be 41mm back to back

For 32mm gauge (SM32) wheels should be 28mm back to back.

Use Cyanoacrylate adhesive ( Superglue ) or Epoxy to secure axleboxes to chassis.

ABS welding slovent is best for other parts. Liquid polystyrene solvent ( Humbrol liquid poly ) can be used but apply generously. The kit is made of ABS which is harder and more chemically resistant than polystyrene so requires more liquid solvent to weld it. The polystyrene cement that comes in tubes not recommended.

Axleboxes do not need lubrication but light mineral oil is fine.

Grease is not recommended. Any modellers paint is ok

## **peterbinnie.com - downloads**

 [istruzioni-ribaltabile-italiano.pdf](#)

 [tipvogn-instruktioner-dansk.pdf](#)

 [kipwagen-anleitung-deutsch.pdf](#)

 [tippvogn-instruksjon-norsk.pdf](#)

 [вагон-самосвал-инструкция-русский.pdf](#)

 [wagon-benne-instructions-français.pdf](#)

 [kipwagen-instructies-nederlands.pdf](#)

 [instrucciones-volquete-español.pdf](#)

 [tippvagn-instruktioner-svenska.pdf](#)

Sales website - <https://www.peterbinnie.com/>

Model railway website - <https://www.colinbinnie.com>

© Peter Binnie