

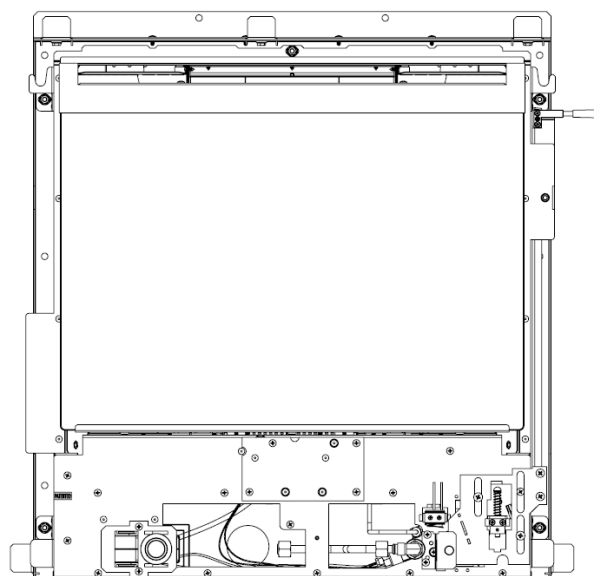

RAVEL 550CF GAS LOG FIRE CONVENTIONAL FLUE



USER INSTRUCTIONS INSTALLATION INSTRUCTIONS SERVICE INSTRUCTIONS

Do not use this appliance if the front glass panel is broken, removed or fitted incorrectly.

It is a regulation that these instructions be handed to the customer after installation is complete. It is also the responsibility of the installation engineer to ensure that the customer is able to fully operate the appliance and is aware of any cleaning or maintenance requirements.

Model number: F-061XX2 SLIDE For use on Natural Gas (G20) at a supply pressure of 20 mbar in GB/IE.



**THIS INSTRUCTION MANUAL MUST BE LEFT
WITH THE CUSTOMER AFTER INSTALLATION**

This product is not suitable for primary heating purposes.

USER INSTRUCTIONS

1.0 Appliance Commissioning Check List 3

2.0 User Instructions—Important information & Warnings 4

2.1 User Instructions—Controls & Operation 5

2.2 User Instructions—General Maintenance & 6

2.2 User Instructions—Cleaning & Fuel Bed Information 7

2.3 Log Layout Instructions 9

2.4 Running in and Troubleshooting 14

INSTALLATION INSTRUCTIONS

3.0 Unpacking the appliance 15

3.1 Regulatory Information 16

3.2 Efficiency and Appliance Technical Information 16

3.3 Installation Requirements 16

3.4.0 Siting the Appliance 17

3.4.1 Hearth Requirements 17

3.4.2 Checking the Flue 17

3.4.3 Appliance Dimensions 17

3.5 Debris 18

3.6 Ventilation Requirements 18

3.7 Gas Supply 18

3.8 Installation Methods 19

4.0 Prepare Appliance for Installation 28

4.1 Removal of the Glass Panel 28

4.2 Connecting the Gas Supply 29

4.2.1 Slide Lever Adjustment 30

4.3 Log Layout Instructions 31

4.4 Lighting the Fire 36

4.5 Check for Spillage 37

4.6 Combustible Shelf 38

4.7 Complete the Installation 39

SERVICING INSTRUCTIONS

5.0 Servicing the Appliance 40

5.1 Removal the Burner Tray 40

5.2 Removal of the Gas Valve 41

5.3 Removal of Pilot 42

5.4 Removal of Spark Generator 43

5.5 Removal of the Tee Valve (High Setting) 44

5.6 Removal of the Injectors 46

5.7 Removal of Ceramic Liner 47

6.0 Record of Annual Services 49

7.0 Product Fiche 50

8.0 Manufacturers Instructions and User Replaceable Spares 52

1.0 APPLIANCE COMMISSIONING CHECKLIST

It is the installers responsibility to complete the following checklist when commissioning this appliance. The information recorded on this page may be requested at the time of any warranty call made. If the information is not made available it may affect the warranty support for the customers appliance.

CHECK LISTS	PASS	FAIL
Check flue is suitable for this appliance		
Check flue flow prior to installation		
Check spillage after installation		
Check standing gas pressure		mbar
Check working pressure on full rate (Min. 18.5) Ensure all other gas appliances are running on full rate		mbar
Complete relevant section of warranty forms , ensure it is complete with Gas Safe registration details.		
Instruct the customer on lighting, maintenance and servicing procedures. (Including glass removal and ceramic placement)		

Appliance Serial Number	
Installation Date	
Gas Engineer Name	
Gas Safe Engineer Registration No.	
Gas Safe Engineer contact No.	

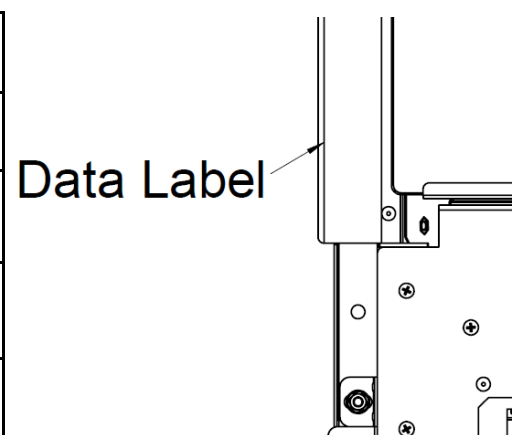

If you can smell gas, immediately turn off the gas supply using the control valve at the meter in your home. Do not smoke and turn off all sources of ignition, i.e. boilers or gas hobs. Open windows and doors to ventilate the room or building.

Call the Gas Emergency Service 0800 111 999 (England Scotland and Wales)
0800 002 002 (N. Ireland)

Welcome

2.0 Congratulations on the purchase of your new Wildfire Ravel 550CF Widescreen gas fire. Ensure you keep these instructions in a safe place as they will be required for installation, service and general upkeep of your appliance.

These instructions should be followed precisely to ensure that you receive many years of trouble free service from your appliance.

Some general maintenance is required by the user to keep the appliance in its best condition, these are detailed later in this instructions manual.

Important

This gas appliance **MUST** be installed by a GAS SAFE registered installer by law. It must be installed in accordance to these installation instructions and the GAS SAFETY (Installation & Use) REGULATIONS 1998 as amended. Non compliance of this law may lead to prosecution and it is in the interest of you and your family that this condition is observed. Check with your gas installer that they have current membership to Gas Safe and that their membership includes gas fires.

It is very important that you also have your gas appliance serviced annually by a Gas Safe registered engineer. During this service the engineer will check the operation and performance of the appliance and also for any debris that may have collected behind the appliance. This is important for you and your families safety.

Check for the Gas Safe logo on your gas engineers membership card.



Warnings

Do not place soft wall coverings (i.e. embossed papers etc,) furniture or other combustible items too close to the fires as they may discolour or scorch.

Do not place or throw rubbish or otherwise on the fuel-bed.

Do not place any combustible materials or flooring (i.e. carpets etc,) on any part of the hearth.

Many parts of this appliance and some surrounding areas will be come hot during use.

This appliance has a naked flame and as with all heating appliances a fireguard should be used for the protection of children, the elderly and infirm. The fireguard should conform to BS8423 : 2002 (Fireguards or use with Gas Heating Appliances).

It is quite normal for a flame effect gas appliance to experience a small amount of soot or staining to some parts of the fuel effect components. If this becomes excessive it may be because the fuel bed is not fitted correctly — this should be checked according to these installation instructions prior to contacting a service engineer.

NEVER place any rubbish or otherwise onto the fire—this will affect the way the product operates and may affect the warranty of the product.

NEVER place more ceramic components onto the fuel bed than specified in the instructions.

NEVER touch the ceramics when the appliance has recently been switched off—these components retain heat and may cause burns. Leave the appliance to sufficiently cool prior to any contact of the ceramics.

Ventilation

No purpose made ventilation is normally required for this appliance when installed in G.B. If the appliance is being installed in I.E then refer to I.S 813:1996 (Domestic Gas Installation—National Standards Authority of Ireland). Ventilation areas (if applicable) should be checked periodically to ensure there is no obstruction, even though none is normally required for this appliance.

Controls

2.1 This appliance is operated with slide control lever. It is located on the upper right side of the appliance.

The lever slides vertically up and down and this movement controls all functionality of the appliance, from ignition, flame control and turning the appliance off.

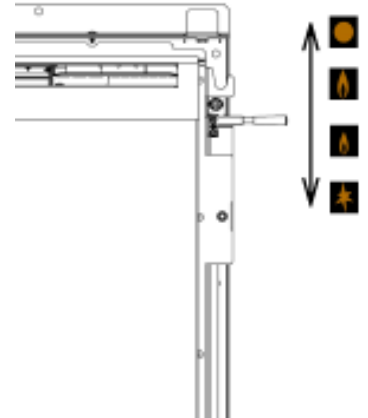

Lighting

Slide the control lever downwards to the ignition symbol. After a few seconds the pilot light should light.

If the pilot light does not light, release the control knob and wait for 3 minutes before reattempting. If the pilot does not light after 3 attempts, check the battery—see page 6. If the battery is new and the pilot still fails to light, contact a gas safe engineer.

Once the pilot is lit, keep the lever pushed downwards for up to 10 seconds then release. The pilot should stay lit and the central and front log burners will now light.

The appliance is now running at the LOW setting.

Slide the lever upwards, until a slight stop is felt, to turn the rear log burners on. The appliance is now running at the HIGH setting.

To turn the fire off, slide the lever upwards to the OFF symbol.

Should the spark generator fail to provide a spark at the electrode it may be that a small amount of soot has fallen from the fuel bed onto the pilot assembly, causing a short circuit. If this is the case, ensuring the appliance is off and cold, this area can be cleaned with the thin nozzle from a vacuum cleaner. See page 8 for details on glass removal to access this area.

Alternatively check the battery is in good condition—see page 6 for details.



Battery

2.2 This gas appliance uses a single AA type battery which supplies the power for the spark generator used during the ignition process. The battery box which houses this battery is located behind the trim/decorative frame in the lower left hand corner. See diagram.

Unscrew the black plastic cover to access the battery compartment. Replace the battery ensuring correct polarity.

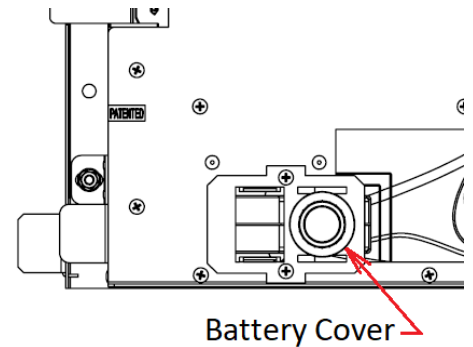

Trim

There are two trim types available for this appliance, an inset stove style or a contemporary trim. The installation varies depending upon the trim style being used. Full details on the installation appear later in this instruction manual. If the trim is removed, always ensure it is stored somewhere safe where it cannot be damaged.

Glass Panel

Removal Top Trim Cover.

The top trim cover must first be removed to access the glass retainer. The top trim cover is held in place by two small square magnets.

Removal of the front glass panel.

The top glass clamp is held in place with 3 screws.

Carefully loosen the 3 fixing screws whilst supporting the glass panel, remove the clamp. Now lift the glass from the appliance. The bottom edge of the glass is retained in the two supports bottom left and right.

Store the glass panel where it cannot be damaged.

Now the ceramics can be installed, rearranged correctly or removed for service. Correct installation of ceramics see pages 9-13.

Installation of the front glass panel.

Before replacing the glass ensure that the seal around the top and two sides of the firebox is in good condition and is securely affixed to the appliance. If the seal is damaged or loose then it should be replaced / reaffixed before the glass is replaced. This seal is important and if damaged, the appliance should not be operated.

Replace the glass panel into position by locating the bottom edge into the two lower supports, and securing the top edge with the top clamp. Tighten the three (3) fixing screws (as detailed above).

Ensure the two magnets are in the correct position (see above) then the top cover can be replaced. This component is purely decorative and is used to conceal the top clamp fixing structure. Never leave this strip in place without the correct magnets in position.

Never run this appliance with a damaged or broken glass panel.

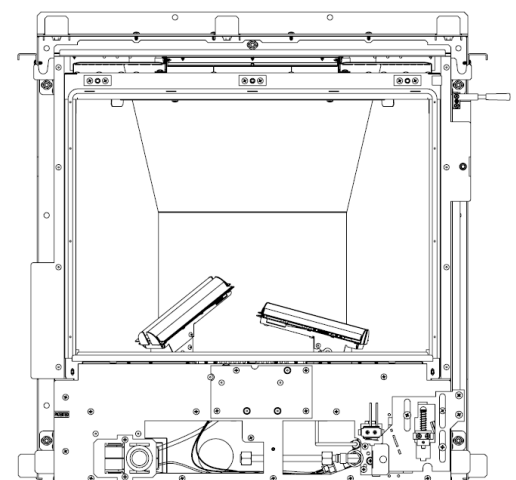
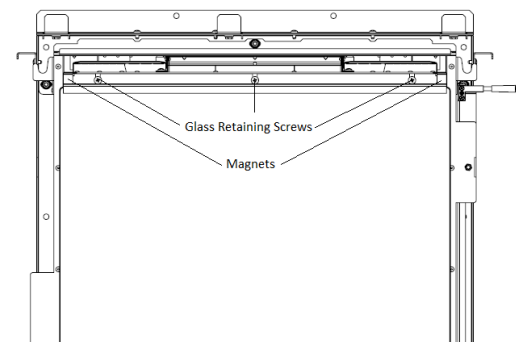
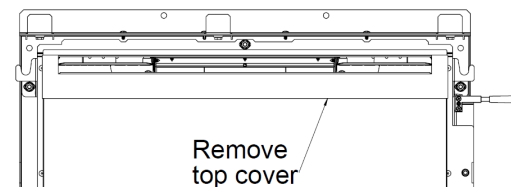

Cleaning

Cleaning is recommended for some parts of this appliance. The glass can be cleaned with a non abrasive glass cleaner and lint free cloth. Metal parts can be cleaned with a lint free damp cloth.

Fuelbed

HEALTH AND SAFETY NOTICE

This appliance uses fuel effect pieces manufactured from Refractory Ceramic Fibres (RCF). Care must be taken to avoid excessive exposure to these materials as they may cause irritation to the eyes, skin, nose and throat. When Handling avoid inhaling and contact with skin and eyes. It is recommended that disposable gloves are worn in addition to a facemask and eye protection. After handling wash hands thoroughly and any other exposed parts which may have come in to contact with the material.

If a vacuum cleaner is used to clean the fuel bed or areas around the appliance where fragments of the material may have fallen it is recommended that it be of the type fitted with a **HEPA** filter.

Care should be taken when disposing of RCF materials. It is important to keep any dust to a minimum so it is recommended that the fuel effect components are placed into a heavy duty plastic bag. The bag should be clearly labelled **RCF WASTE**. These materials are classified as hazardous waste and should be disposed of at a site approved for the disposal of industrial waste.

The fuel effect components supplied with this product are extremely fragile and must be handled with great care. The ceramics in this appliance are not covered by the warranty due to their fragility. This includes the RCF fibre boards in the fire box. These components will break or chip if not handled with the greatest of care.

Cleaning of these components should only be undertaken once the appliance is switched off and has been allowed to cool for a minimum period of one hour. The components should be lifted carefully piece by piece from the appliance and placed onto a dust sheet or similar. They can be brushed gently with a soft brush to remove any dust or deposits. If you intend to use a vacuum cleaner then this should only be done once the loose deposits of soot etc have been removed. Ensure that the moulded components are structurally sound and no significant part of the moulding has broken away. If any component has broken then it should be replaced before using the appliance. Only the correct replacement part as supplied by the manufacturer shall be used in this appliance. Do not add any additional components to the fuel bed layout. It is important to note that small hairline cracks will appear in the surface of the ceramics due to heat expansion and contraction—this is perfectly normal.

See the full details of log and fuel bed installation on page 9 for removal and replacement of the ceramic log and bark components.

Pilot

It may be necessary to clean areas around the pilot assembly. If the appliance is running and then turns itself off automatically for no apparent reason, it may be that the O.D.S (oxygen monitoring device) has become partially blocked and may need to be cleaned.

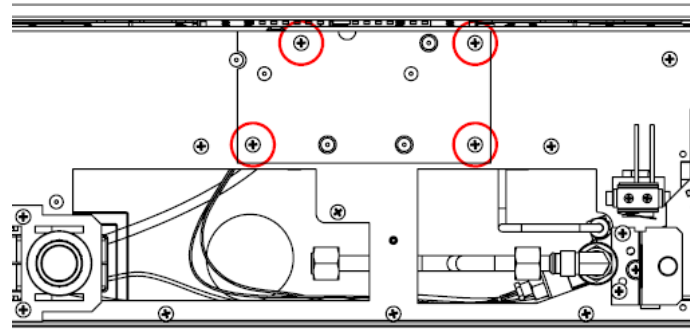

The pilot on this appliance has a small aeration hole at its base, sometimes lint and dust can be drawn in with the air supply to the pilot.

To reduce the occurrence of such lint ingestion it is recommended that the area directly in front of the appliance is cleaned regularly. This problem can be worse where wooden floors are present, as lint is more free to move on these areas. Pet hair can also cause this problem.

Using a thin nozzle on a vacuum cleaner this area can be cleaned to remove any lint build up. Apply the end of the nozzle to the aeration hole for up to 2 minutes, regularly removing and reapplying the tip of the nozzle to vary suction.

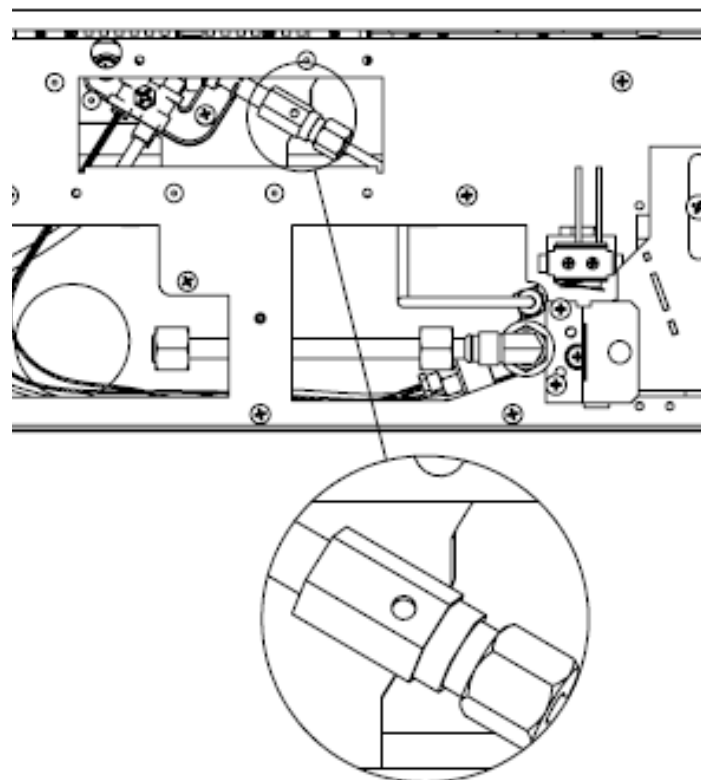

If this procedure does not resolve such a problem then the pilot assembly will need to be replaced. This must involve the installation of the same part as supplied by the manufacturer. Excessive lint build up which results in appliance operational problems is not covered by warranty. It is important to ensure this preventative maintenance is performed regularly.

Log Setup

2.3 The following instructions detail how the ceramic fuel bed and loose components are to be installed onto the appliance. Great care should be taken when handling these ceramic parts as they are fragile and can easily be broken. Do not force any component into position, if it does not fit easily then you are not fitting the part correctly. These instructions can also be followed to remove or reinstall the fuel bed after cleaning. This is a procedure that can be undertaken by the customer as required and the frequency will be depend upon use.

See page 6 for glass panel removal and installation.

The fuel bed setup involves the installation of volcanic rock, ceramic bark, ember wire and a boxed set of ceramic decorative logs. These components will have been installed by your gas engineer at the point of installation, however it is permitted for the end user to remove clean and replace these components as necessary. The following installation instructions must be adhered to at all times.

The following diagram is for identification purposes. It is imperative that the logs are placed in the correct position for safety and also to ensure that you obtain optimal performance from your appliance.

Identify

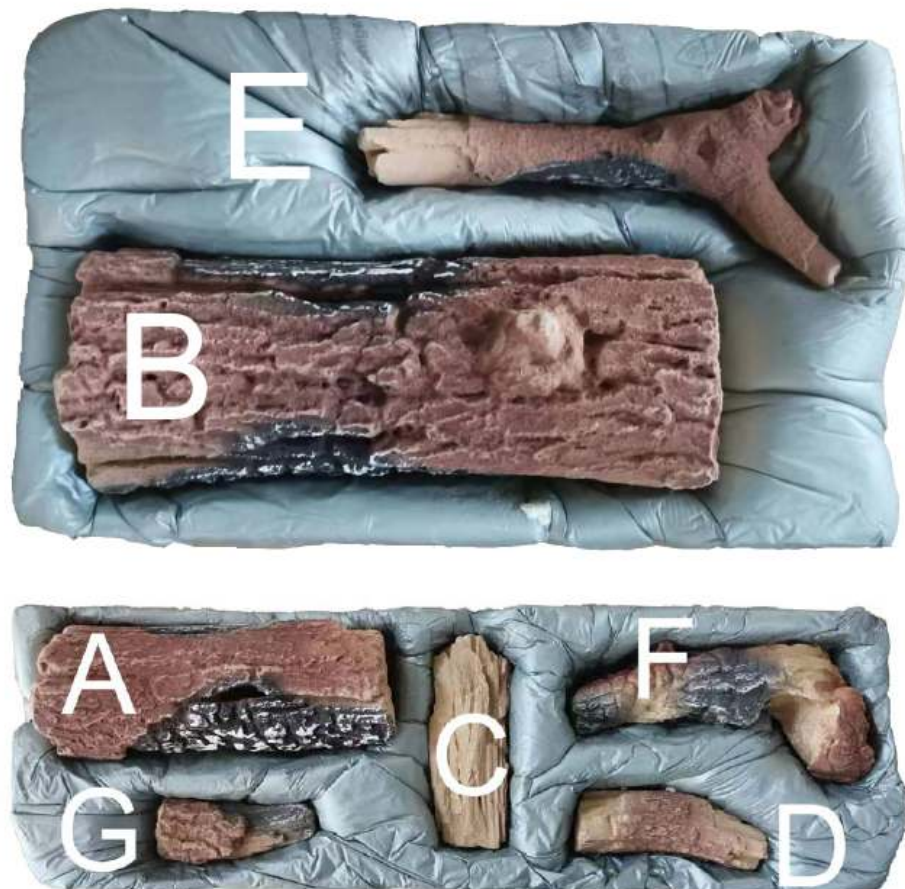

FUELBED

Place the volcanic rock on top of the centre burner as shown. Ensure a 4-5 mm gap is left between each piece. Then using **half** of the glowing ember wire supplied, ruffle between fingers to make it loose, about 20mm wide and long enough to cover the volcanic rock then align over the rock as shown. Ensure no wire is placed within 25mm of the pilot assembly. Retain the other half of the wire for replacement at annual service.



Place Log D as shown in the picture.



Place Log C as shown in the picture.



Place Log E as shown in the picture.



Place Log A as shown in the picture.



Place Log B as shown in the picture.



Place Log G as shown in the picture.



Place Log F as shown in the picture.



Running In

2.4 When this appliance is first used it is important to note that you will experience some fumes and smells in the room of operation. Any fumes emitted during the first few minutes of use can be quite pungent and it is advised that a window is opened until this subsides. Smells associated with paints, oils and starch from ceramic components may last several hours but will rapidly diminish over the first few uses of the appliance.

It is advisable that the appliance is always run on high for a period of at least 20 minutes before turning to low, to ensure optimal flue performance and to reduce the possibility of sooting.

It should be noted that as with all flame effect gas appliances, some sooting can be evident and can be cleaned away—see cleaning instructions on previous pages.

Trouble Shooting

The following table should be used to identify any problems experienced with the operating or running of your appliance prior to contacting the manufacturer or retailer regarding service.

THE FIRE WILL NOT LIGHT

Can you hear a continuous clicking during the ignition process?	YES ↓	NO Check Battery
Does the pilot light?	YES ↓	NO Check and remove soot or ember wire near the pilot
Does the pilot go out when the lever is released?	YES →	Try again, but before releasing the lever give a firm push down before releasing the lever.

THE FIRE GOES OUT

Does the fire light and run ok then subsequently turns off automatically	YES →	The pilot aeration may have become blocked refer to page 8
--	-------	--

VISUAL PROBLEMS

Does the flame picture look wrong?	YES →	Check log placement as per the user instructions see pages 9-13
Does the glass have grey water marks on inside surface	YES →	The glass will require infrequent cleaning dependant on use. See page 6 to open door.
Do you see marks or discolouration above the centre of the appliance?	YES →	The gas fire is spilling, turn the unit off and call for your gas safe engineer.

Warranty



The Wildfire 5 year limited guarantee is managed directly by Hearth Products Ltd. With our experienced Gas Safe engineers and through our extensive network of service centres throughout the UK we will ensure your appliance receives the right care should anything fail prematurely. Choose Wildfire for style, performance, reliability, value and peace of mind.

Unpacking Appliance

3.0 TAKE GREAT CARE WHEN UNPACKING THE APPLIANCE—SOME PARTS CAN BE EASILY DAMAGED.

Once the carton has been opened, carefully remove the polystyrene packing components to reveal the appliance. Lift the appliance from the carton and remove the trim and store in a safe place whilst the installation takes place. (if applicable*).

*If the Ravel 550 is being installed with the Inset Stove trim, this will be supplied in a separate carton.

Check the accessory packs before commencing the installation.

There will be **two** plastic bags located in the carton:

1. Tools & Fittings Pack
 2. Instructions and guarantee registration form.
- Note that the guarantee registration can be performed online at:

www.hearthproducts.co.uk/register-new-product/



TOOLS & FITTING PACKAGE			
Item	Picture	Description	Qty
1		Rubber Grommet	1
2		STAINL Screw	6
3		Magnet	2
4		Insulation Elbow	1
5		Foam Seal	1
6		Stainless Steel Pipe	1
7		Wall Fixing Plug	8
8		Nails	1

TOOLS & FITTING PACKAGE			
Item	Picture	Description	Qty
9		Flue Nut	1
10		Carbon Wire	1
11		Flue Cable	2
12		Adjuster Fitting	2
13		Nuts	3
14		Flue Cable Clamps	2
15		Screened nipples	2
16		Eye-bolts	4

Regulatory Information

3.1 NOTE THE FOLLOWING PRIOR TO THE INSTALLATION OF THIS APPLIANCE.

This gas appliance **MUST** be installed by a GAS SAFE registered installer by law. It must be installed in accordance to these installation instructions and the GAS SAFETY (Installation & Use) REGULATIONS 1998 as amended. Non compliance of this law may lead to prosecution and it is in the interest of you and your family that this condition is observed.



The installation of this appliance must be in accordance with the relevant parts of the LOCAL AND NATIONAL BUILDING REGULATIONS as issued by the Department of the Environment or BUILDING STANDARD (Scotland Consolidation) REGULATIONS issued by the Scottish Development Department and the following relevant British Standards:

BS5871	Part 2 Installation of Inset Live Fuel Effect Gas Fires
BS5440	Parts 1 & 2 Installation of Flues and Ventilation
BS6891	Installation of Gas Pipe-work
BS6461	Part 1 Installation of Chimneys and Flues
BS1251	Open Fireplace Components
BS715/BS EN 1856-2	Metal Flue Boxes /Metal Flue Pipes for Gas Appliances
BS EN 1858	Chimneys Components & Concrete Flue Blocks
IS813:1996	Domestic Gas Installation (Republic of Ireland)

Efficiency /Technical

3.2 The efficiency of this appliance has been tested to BS7977: 84.9% net (76.4% gross) & EN613 82.5% net(74.3% gross). This efficiency value has been verified by Kiwa (0558). This efficiency value can be used for SAP (Standard Assessment Procedure) for energy rating of UK dwellings.



Appliance Technical Information

GAS TYPE: NATURAL	GAS CATEGORY: I _{2H}	INLET PRESSURE: (COLD) 20mBar
HEAT INPUT: GROSS 4.7kW	INJECTORS: 0.75 0.78 0.81 (2) (1) (2)	DESTINATION COUNTRIES: GB/IE

Installation Requirements

3.3 Prior to installation ensure that the gas supply is compatible with the appliance, this appliance must only be used on **natural gas** at a supply pressure of 20 mbar as marked on the data plate on the appliance and the carton.

This appliance is only to be installed into a builders opening which must be constructed of non-combustible materials confirming to BS1251 or a suitable flue-box complying with the requirements of BS715/BS EN 1856-2.

The chimney must only serve as a flue-way to this appliance and must have no openings to any other room. The opening should be inspected and any exposed brickwork should be repaired where necessary. The chair- brick (if applicable) should be removed. Ensure that the chimney/flue only serves one fireplace. Remove or securely fix open any dampers or register plates.

If the product is being installed into a fabricated Flue-box (to BS715) it must be installed onto a non-combustible surface with a thickness of at least 12mm.

The flue should be checked for draw using a smoke bomb or similar, if there is a definite draw then the installation of the appliance can proceed.

Site Requirements

3.4.0 This appliance must be installed into a suitable fireplace. The chimney or flue must be either Class 1 (brick chimney or 7" diameter flue) or Class 2 (5" diameter flue) The minimum effective height of the flue must be 3 metres, (10'). The flue must be clear of obstruction and if the previous installation was intended for solid fuel it must be swept prior to this installation proceeding.

Installation into a Brick Chimney

When the appliance is being installed into a brick chimney there must be sufficient depth behind the appliance to accommodate any falling debris. This debris collection void should be capable of accommodating twelve (12) litres of volumetric space. The appliance will normally require a debris collection space behind the firebox of 39mm.

Installation into a Prefabricated Twin Wall Metal Flue Box

This appliance can be installed into a prefabricated metal twin wall flue box providing it complies to the requirements of BS715 / BS EN 1856-2. The box must have an insulated flue with a minimum diameter of 125mm (5") diameter and a minimum effective overall height of 3 metres.

The top outer face of the flue box should be insulated to prevent heat loss with a layer of mineral wool insulation or similar. The metal flue box (to BS715) must stand on a non-combustible surface with a minimum thickness of 12mm.

This appliance can be installed in two configurations. See Page 19

TYPE A Into a STANDARD 16" x 22" **back panel** with an **INSET STOVE FRONT**.

TYPE B Into a STANDARD 16" x 22" **fireplace opening** in conjunction with a **76mm rebate** mantel/back panel with a cut out size of 570mm (W) x 590mm (H).

This type of installation will incorporate a **CONTEMPORARY TRIM**.

Hearth

3.4.1 A hearth constructed of non combustible materials must also be installed which is a minimum of 12mm in thickness. This appliance must not be installed directly onto carpet or other combustible floor materials. It is recommended that a hearth extends 150mm forward and each side of the appliance to provide a physical boundary from the hot surfaces, however this is not mandatory.

Check The Flue

3.4.2 Use a smoke pellet prior to the appliance installation to ensure the viability of the flue and check that the smoke can be seen being emitted from the terminal / chimney pot outside. There must be no leakage of smoke through the structure of the chimney/flue during or after the smoke pellet test and it is important to check inside upstairs rooms adjacent to the chimney / flue. Check the chimney pot / terminal and general condition of the brickwork or masonry. If the chimney or flue is in poor condition or if there is no up-draught do not proceed with the installation. If there is a history of down-draught conditions with the chimney / flue, the installation of a tested and certificated flue terminal or cowl suitable for the relevant flue type should be considered.

Appliance Dimensions

3.4.3 The following diagram shows appliance dimensions..

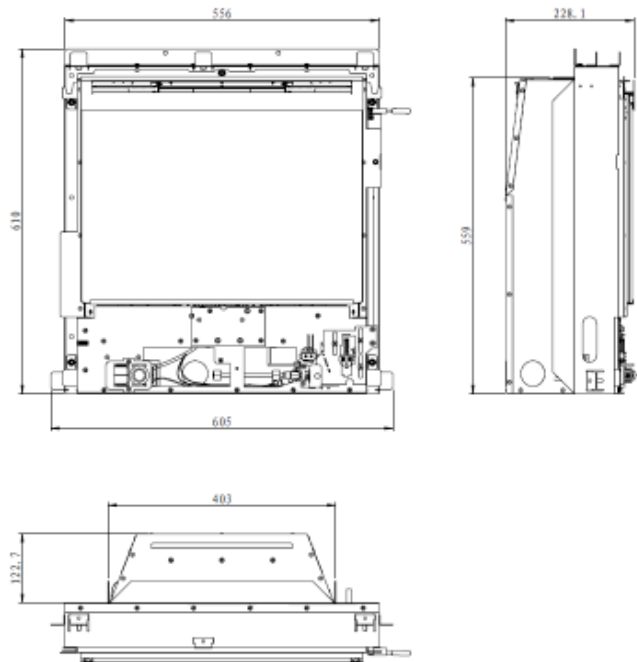

Debris

3.5 A clearance of at least 39mm is required behind the appliance to ensure adequate debris collection volume is attained and provide to clearance when venting from the rear exit.

Ventilation

3.6 No purpose made ventilation is required for this product as the nominal input does not exceed 7.0 kW, however if spillage is detected during the installation commissioning it may be necessary to provide some additional ventilation. Always check the current rules in force for the country of installation.

Gas Supply

3.7 This appliance is suitable for use on natural gas (G20) only from a governed meter. It is the responsibility of the installer to ensure that correct pipe sizing has been supplied to the site for correct performance. 8mm diameter ductile copper tubing should be used for the run to the appliance at a maximum length of 500mm to avoid pressure drops. The appliance is supplied with a restriction device which must be used as part of the installation. There should be no soldered joints within the firebox of the appliance.

Methods of Installation

3.8 Installation methods of the Ravel 550.

THIS APPLIANCE HAS 2 DIFFERENT INSTALLATION METHODS:

INSTALLATION TYPE 'A'

The appliance is installed into an existing fireplace suite which has a 16" x 22" back panel opening. The OUTER BOX of the appliance seals onto the back panel as shown in the diagram below.

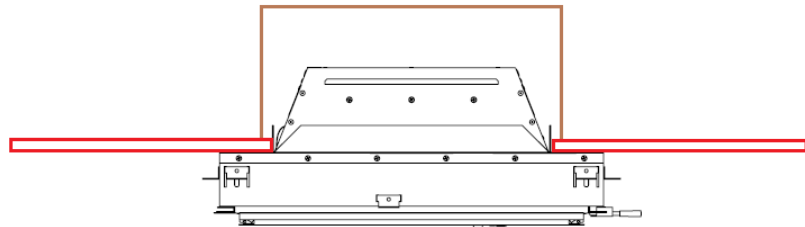

INSTALLATION TYPE 'B'

The appliance is installed into a fireplace opening which has a 16" x 22" opening. The OUTER BOX of the appliance seals onto the wall and is encapsulated with a new fireplace suite. The suite requires a 76mm rebate and a back panel with a cut out size of 570mm (W) x 590mm (H).

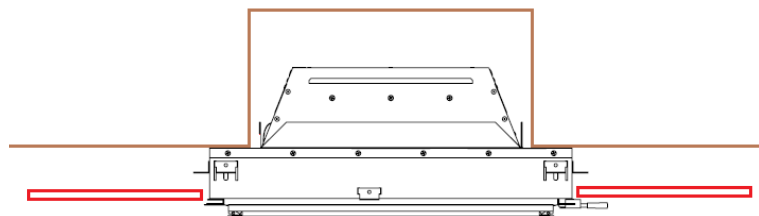

The following diagrams show the installation of the appliance in both of these configurations.

Installation
Type A

3.8.1 A non-combustible fireplace back panel is required with a temperature rating of at least 150°C. (This is also known as CLASS "O" - If in doubt please contact the supplier of the back panel to check suitability). It is recommended that the back panel be constructed of 3 sections with joints across the upper level of the fireplace opening to allow for expansion and contraction. This back panel should then be bonded to form a single piece using a suitable substrate. The installation of this appliance into an unsuitable back panel, where this component subsequently cracks, will not be deemed to be a fault of the appliance. A flat face of a minimum 630mm wide and 630mm high is required to ensure a good seal is formed between the OUTER BOX and the back panel.

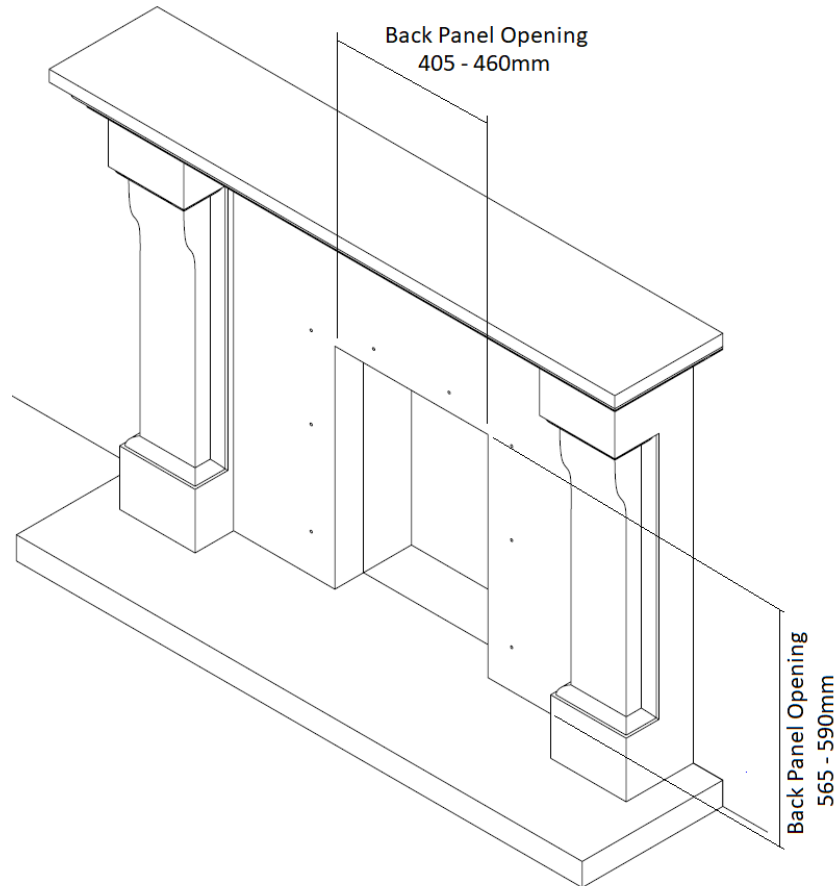

Fit the rubber seal to the rear face of the OUTER BOX, ensuring that the seal makes contact with the back panel over its entire length. This seal should sit within 50mm of the fireplace opening and run around the entire perimeter of the fireplace opening.

This OUTER BOX is screwed to the wall using the 8 screws and rawl plugs provided or by cable fixing if it is not suitable to drill holes in the back panel. See next page.

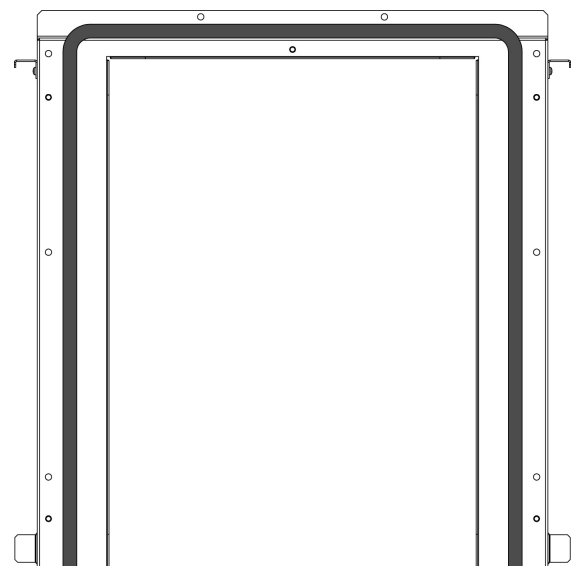

Installation
Type A

3.8.2 The back panel can be drilled as shown, to allow the OUTER BOX to be securely fitted to the back panel of the fireplace. Use the screws and rawl plugs supplied in the fitting kit.

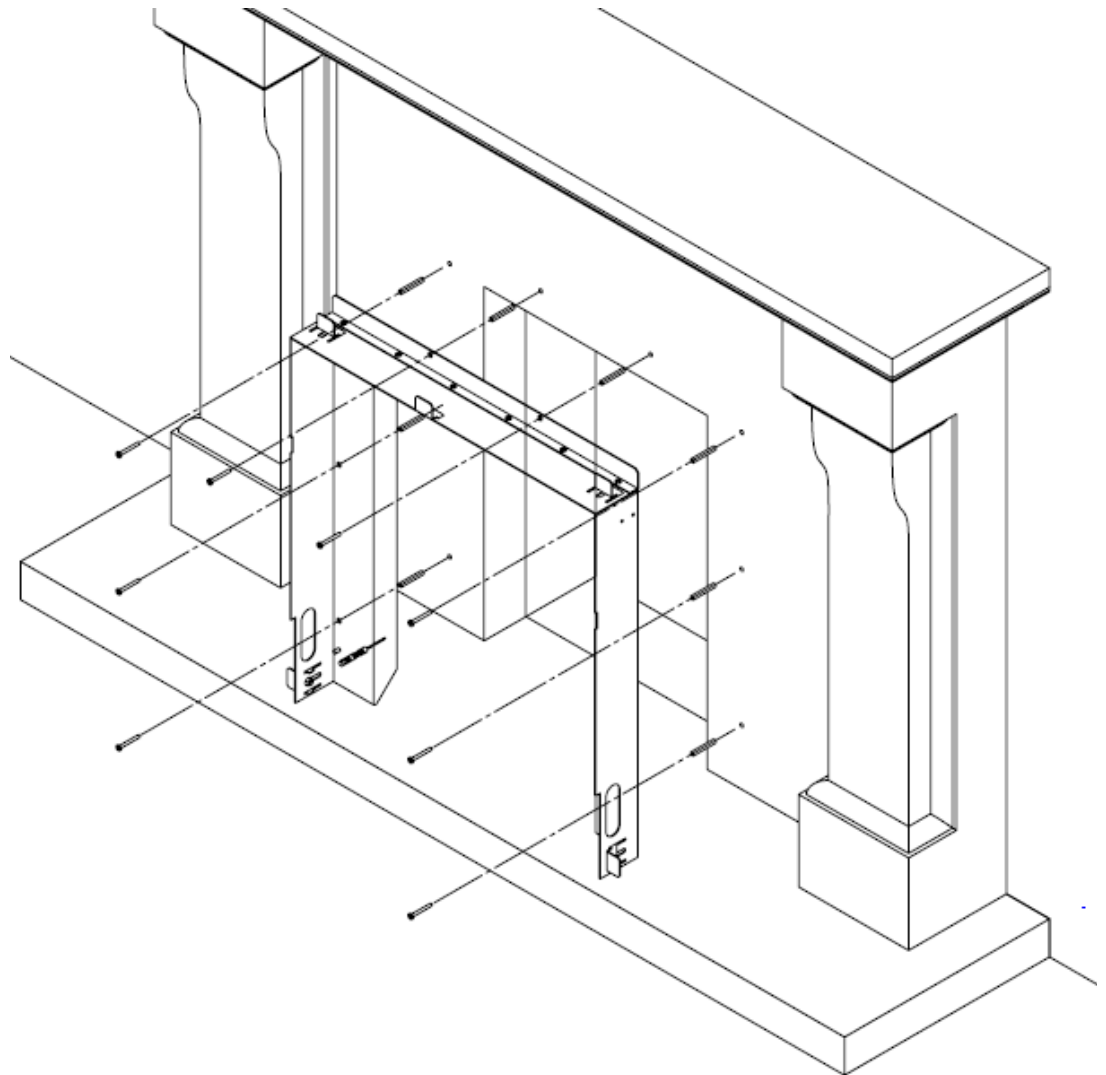

This method of installation requires the OUTER BOX to be removed from the assembly using the magnetic extension tool supplied. Ensure that the OUTER BOX is securely fitted to gain a seal against the back panel, but do not overtighten to prevent cracking of the mounting face.

The appliance can now be refitted to the OUTER BOX , securing with the 5 nuts previously removed.

Alternatively, the complete assembly (Appliance and OUTER BOX) can be fitted as a single unit using the cable tie method detailed on the next page.

Installation
Type A

3.8.3 Cable Fixing System (Alternative Securing Method)

Alternatively, the OUTER BOX can be left attached to the appliance and the complete assembly can be secured into the fireplace opening using the two cables and fittings supplied. This appliance is best installed with the cable fitting system which is supplied in the standard fitting pack. The fitting system comprises four (4) eyebolts, two (2) fixing cables, two (2) screwed nipples, two (2) fixing cable clamps, two (2) nuts and two (2) adjuster fittings.

This installation requires that the burner tray is removed from the firebox (See Burner tray removal in the Service Section of this manual). Remove the screws securing the burner tray to the firebox and set the tray aside during the firebox installation.

Simply drill and fit the eyebolts in the positions shown in the next diagram. Then thread the fixing cables through the two small holes at the top/rear of the appliance, pass each cable through two of the eyelets then back through one of the two holes at the rear of the appliance. Thread the cable through the adjuster fittings. When the appliance is in its installed position, pull the cables tight and slide the adjuster to the back of the fire—ensuring the back-nut on the adjuster has been run as far up the thread as possible to the hexagon shoulder. Keeping the cable tight, fit the screwed nipple to the cable and secure. Turn the back-nut on the adjuster fixing and the cable will be tensioned until the appliance is securely fixed.

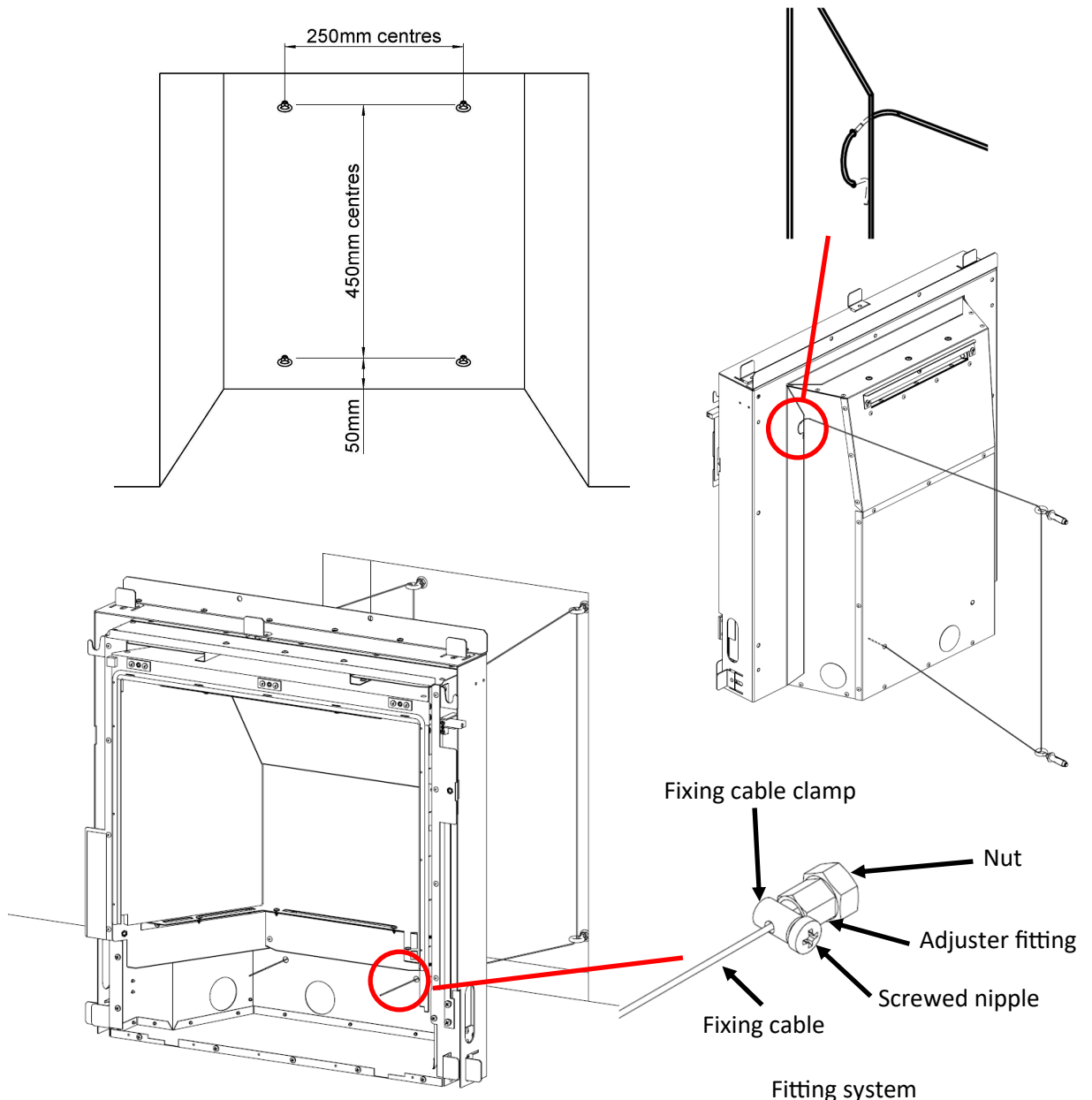

Installation
Type A

3.8.4 Fit the Stove Trim

The Stove Trim can now be fitted to the assembly. Ensure that the slide lever is not fitted to the appliance, if it is, it will need to be unscrewed and removed for the Stove Trim installation to take place.

Simply lower the Stove Trim over the appliance to locate over the two mounting lugs on the OUTER BOX.

Next, screw the slide lever into the appliance through the side slot in the STOVE TRIM.

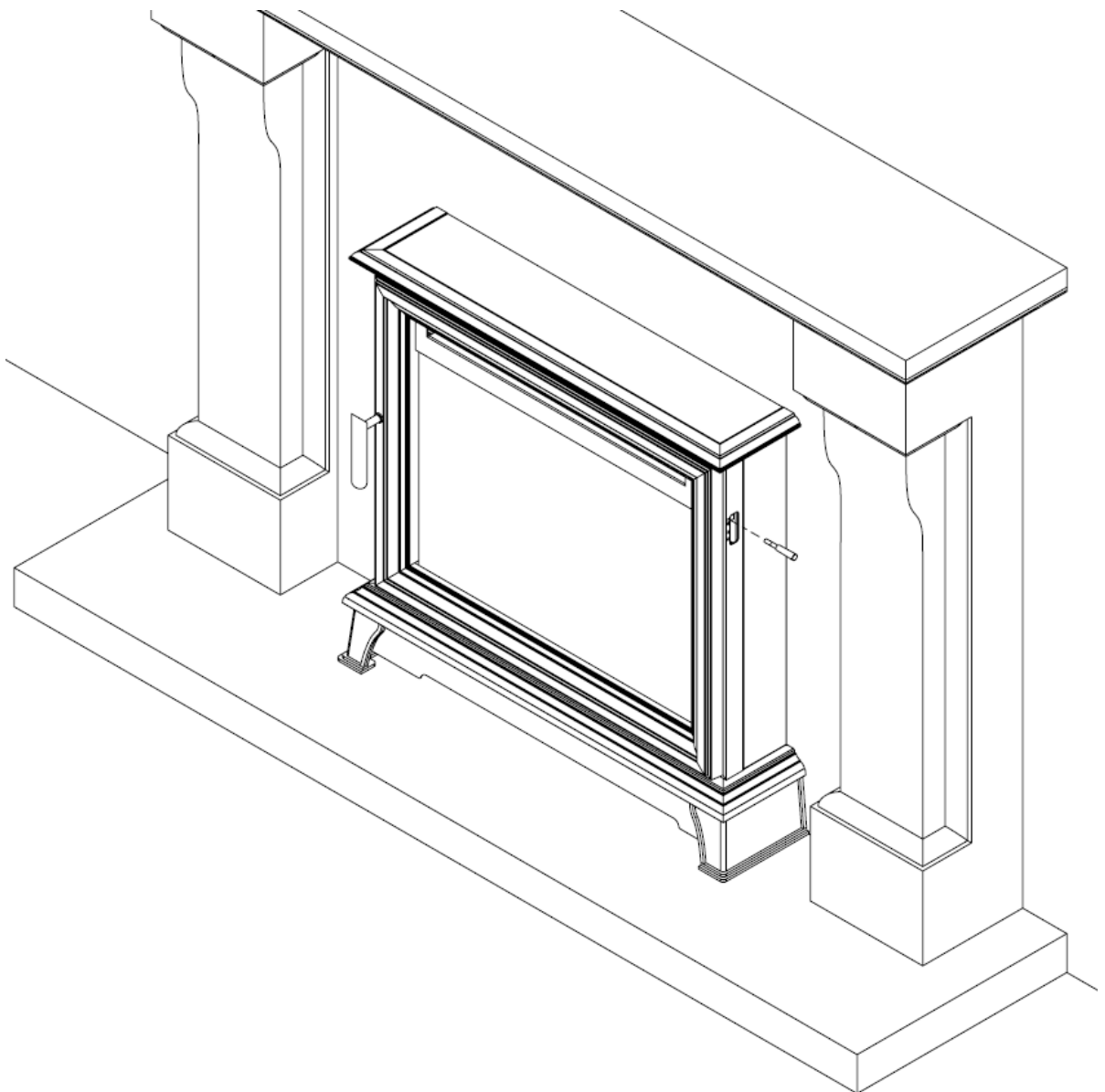

Installation
Type B

3.8.5 This installation type will require a fireplace suite with a specific back panel opening and will include the installation of a contemporary one piece trim.

This appliance **DOES NOT** seal onto a marble or stone back panel. The fire is installed **directly onto the wall** using the OUTER BOX assembly. This is detailed on the following pages.

This OUTER BOX is also used to support the **marble or stone back panel** during installation.

This back panel should have the following cut-out :

WIDTH 560mm—580mm HEIGHT: 585mm—605mm

This non-combustible fireplace back panel is required with a temperature rating of at *least 150°C*. (This is also known as CLASS"O" - If in doubt please contact the supplier of the back panel to check suitability). It is recommended that the back panel be constructed of 3 sections with joints across the upper level of the fireplace opening to allow for expansion and contraction. This back panel should then be bonded to form a single piece using a suitable substrate. The installation of this appliance into an unsuitable back panel, where this component subsequently cracks, will not be deemed to be a fault of the appliance.

Fireplace Opening & Back Panel Sizes

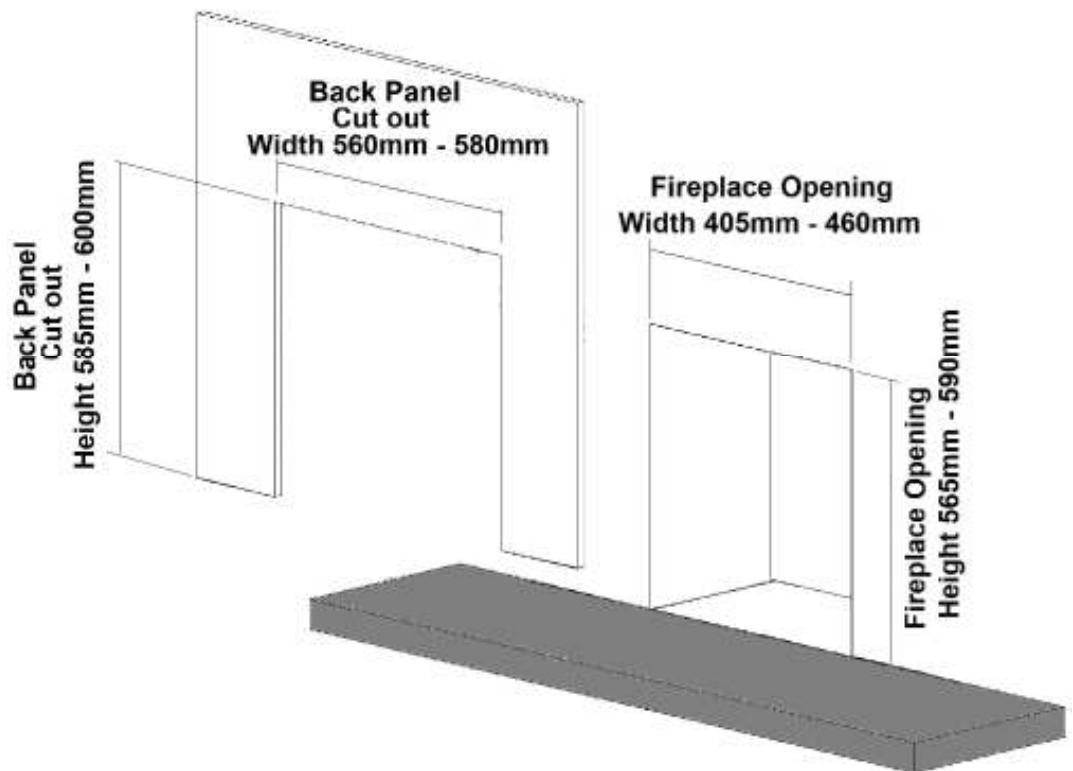

The fireplace opening (**NOT THE BACK PANEL**) must be between 405mm and 460mm wide and between 565mm and 590mm high. The OUTER BOX supplied will fit into this fireplace opening and prepare the installation. If the fireplace opening is outside these dimensions then the opening should be made good to these dimensions using a suitable non-combustible material before proceeding. A flat face of a minimum 630mm wide and 630mm high must be provided around the fireplace opening to ensure a good seal is formed between the OUTER BOX and the wall. In addition it is important to ensure that the base of the fireplace opening is flat and level with the hearth surface to ensure a secure and aligned installation of the appliance.

Installation
Type B

3.8.6 Fit the rubber seal to the rear face of the OUTER BOX, ensuring that the seal makes contact with the back panel over its entire length. This seal should sit within 50mm of the fireplace opening and run around the entire perimeter of the fireplace opening.

This OUTER BOX is screwed to the wall using the 8 screws and rawl plugs provided.

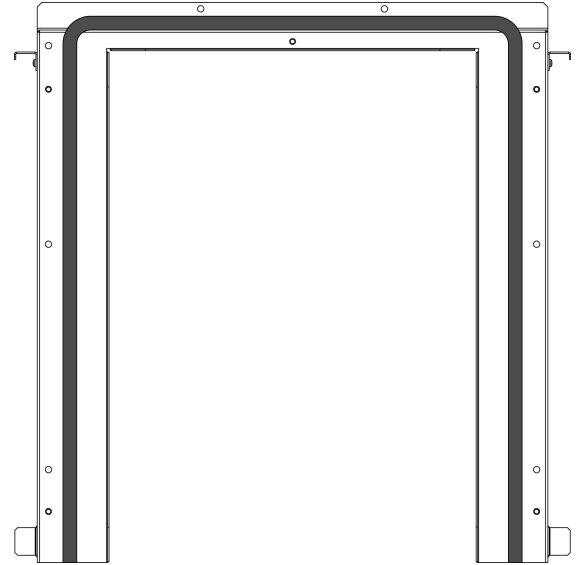

3.8.6.1 Secure the OUTER BOX assembly into the fireplace opening as shown. Use the eight (8) screws and rawl plugs provided.

Ensure that the OUTER BOX is fitted centrally to the hearth.

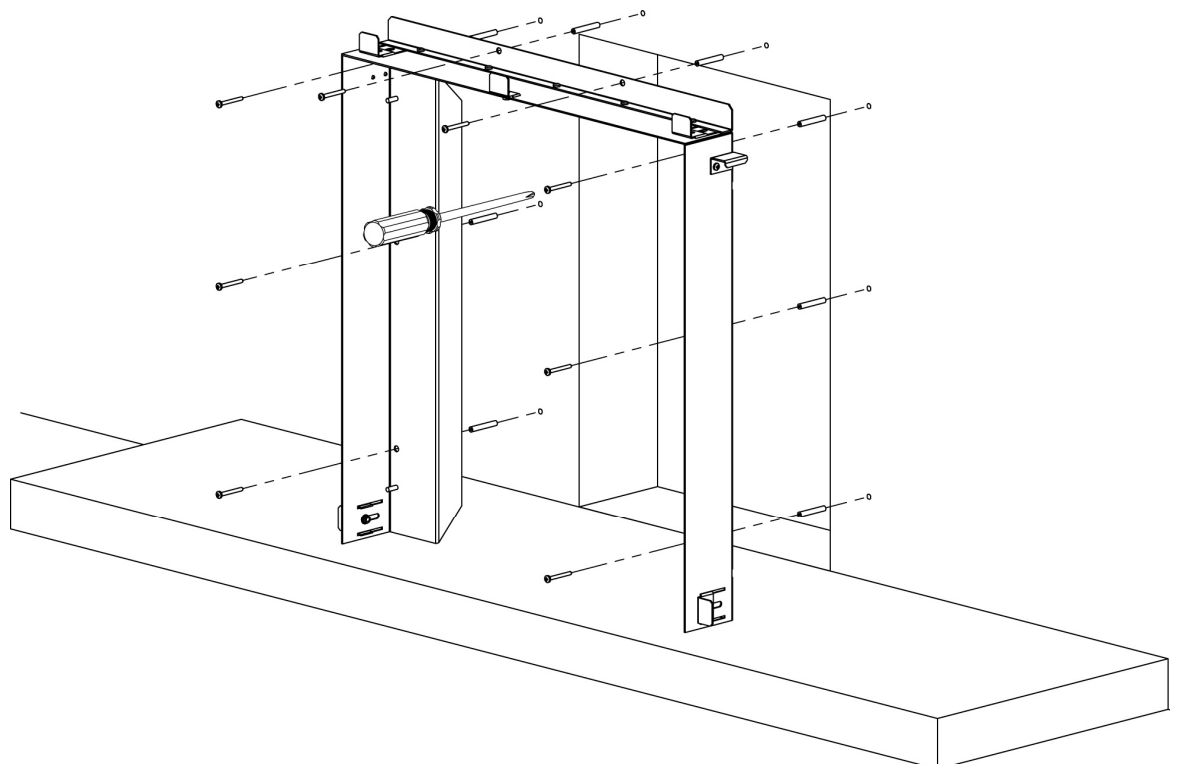

Installation
Type B

3.7 Installing the Back Panel

Ideally the back panel should be constructed from a 3 piece panel and reassembled using suitable materials. This type of back panel will ensure that no corner cracking occurs over time. A 'loose' 3 piece panel can be installed but care should be taken to ensure that the joint line is square.

Ensure that the OUTER BOX is set to provide a 76mm (3") distance from the front face of the back panel, to the wall (See below).

It is recommended that a dry run is performed to ensure that the back panel will in fact be in the correct position when fitted, and that the mantel will fit correctly to the rebate and maintain contact with the wall.

Carefully position the back panel over the OUTER BOX. The front retaining clip will hold the back panel in position while the mantel legs are positioned and fixed. **If necessary this top clip can be removed (after the mantel legs are securely fasted). This would normally only be the case if the wall had extreme variations causing a gap between the back panel and the leg rebates.**

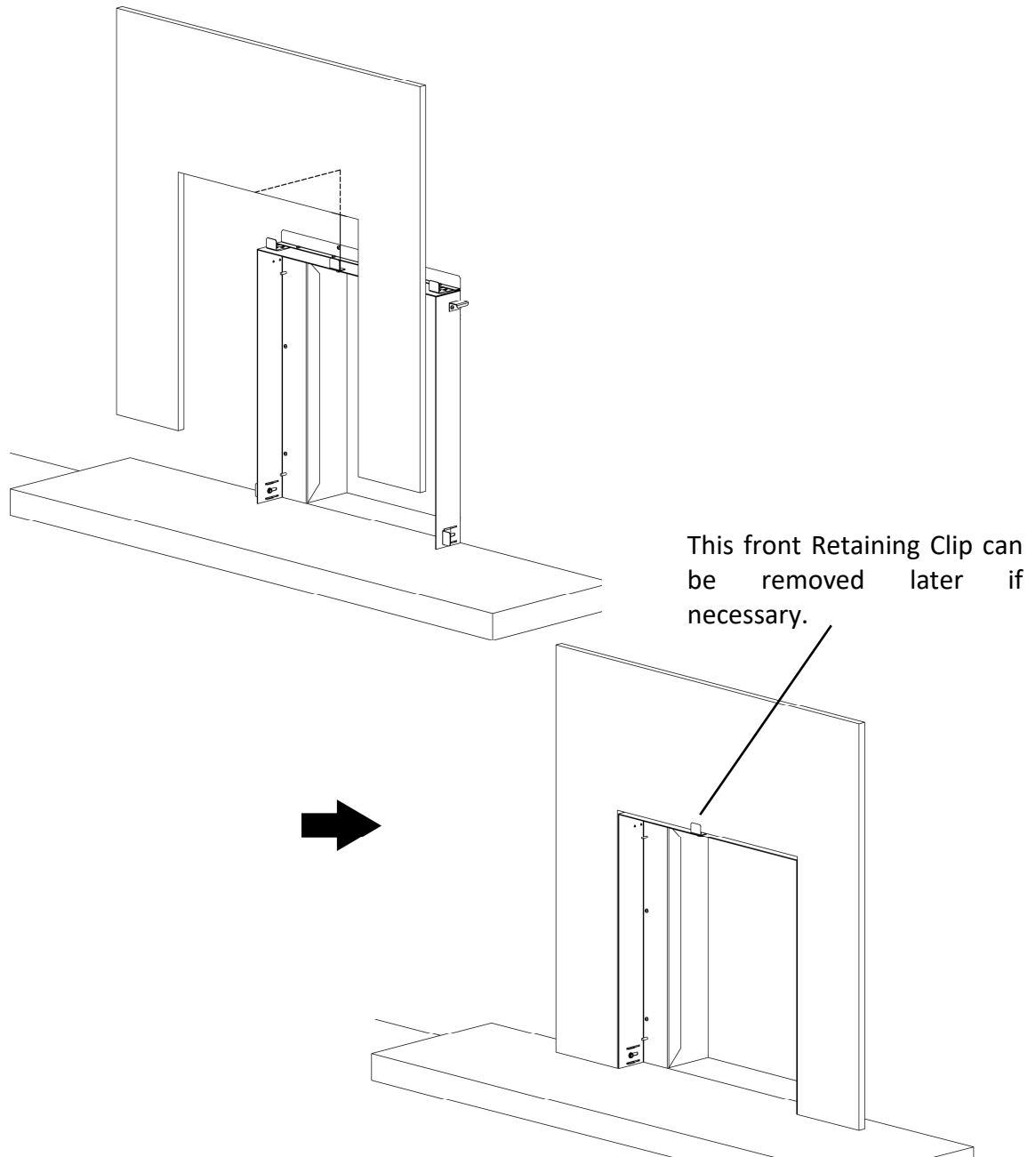

Installation
Type B

3.8 Carefully slide the firebox into the firebox opening. (Note the rubber seal is pre-fitted to the appliance on the sealing face.

Fix the appliance into position centrally on the hearth using the five (5) securing nuts supplied. Note the appliance has slots at these positions to allow a small amount of movement left or right to allow it to be secured centrally. See diagram below.

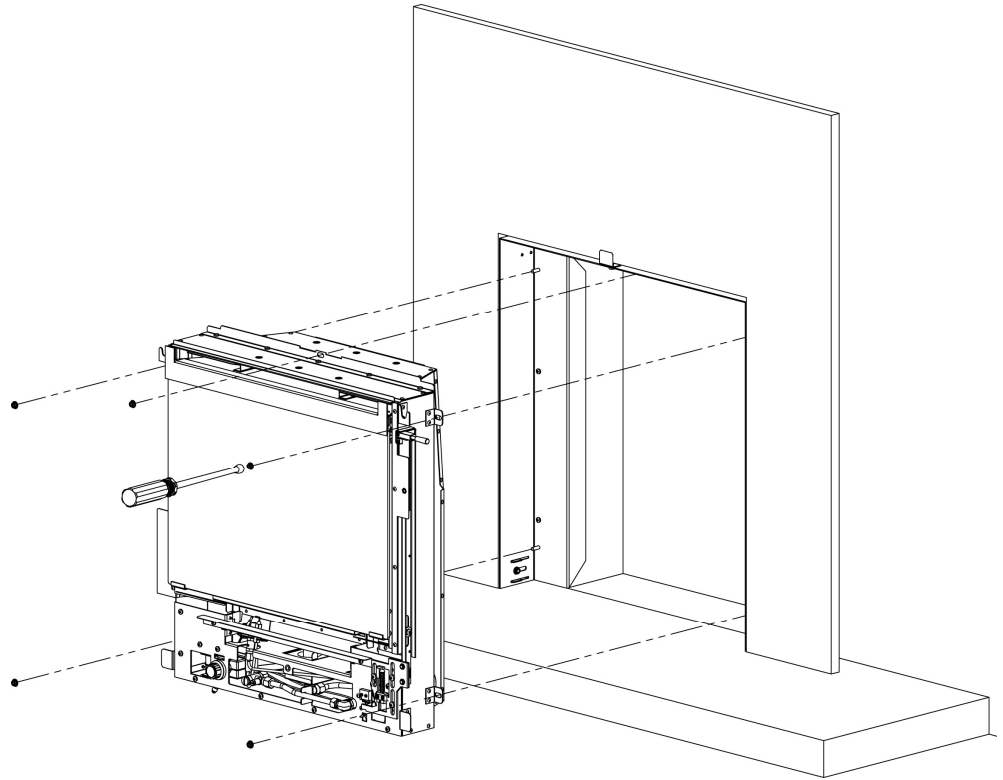

3.8.1 Now lower the contemporary trim onto the appliance so it locates onto the top two locating slots of the OUTER BOX.



Glass Panel Installation

4.0 Prepare the Appliance for Installation

Remove the glass front panel (see below) and the ceramic components from the unit.

Remove the burner tray from the appliance. (See page 40).

If the concealed installation method is chosen, there are three optional entry points at the rear/side of the appliance. The relevant 'knock-out' entry point should be removed to allow the gas supply to enter the appliance.

4.1 Removal of the front glass panel.

The top glass clamp is held in place with 3 screws. This panel is concealed behind the top cover strip which is held in place by two magnets. The two magnets are fitted to the top glass clamp as shown in the lower diagram.

Carefully remove the 3 fixing screws and whilst supporting the glass panel, remove the clamp. Now lift the glass from the appliance. The bottom edge of the glass is retained in the two supports bottom left and right.

Now the ceramics can be installed, rearranged correctly or removed for service. Correct installation of ceramics see pages 9-13.

Installation of the front glass panel.

Before replacing the glass ensure that the seal around the top and two sides of the firebox is in good condition and is securely affixed to the appliance. If the seal is damaged or loose then it should be replaced/reaffixed before the glass is replaced. This seal is important and if damaged, the appliance should not be operated. The glass panel should be undamaged. If the glass panel is broken or cracked it should not be used. Contact the manufacturer for a suitable replacement before continuing.

Replace the glass panel by locating the bottom edge into the two lower supports, and securing the top edge with the top clamp and 3 fixing screws.

Ensuring the two magnets are in the correct position (see above) then the top cover can be placed into position. This component is purely decorative and is used to conceal the top clamp fixing structure.

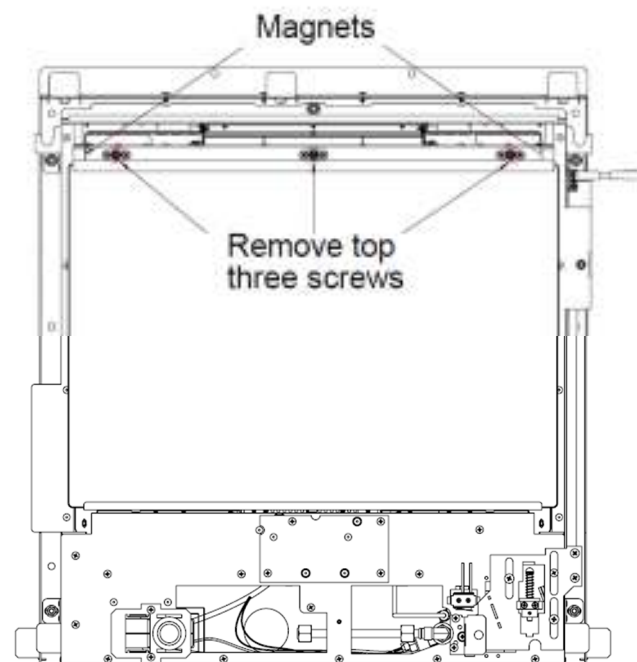
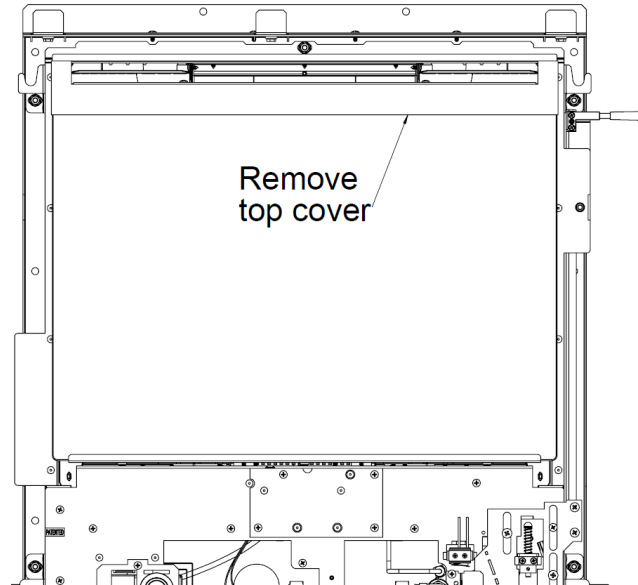

Connecting
To Gas Supply

4.2 Connecting the Appliance to the Gas Supply

The gas supply should be connected to the appliance by a concealed fitting from the rear. In all installation conditions the gas connection should be provided using 8mm (O/D) copper tubing. **No soldered joints** should be used with the firebox of the appliance. The blind grommet which is supplied in the standard fitting pack **MUST** be used to close up the knock out hole—simply cut a small cross with a sharp knife in the centre of the grommet—this will then seal around the gas pipe to provide a tight seal. **Under no circumstances** should this gas entry hole be **left open** and **unsealed** as this can result in **flame reversal** and can cause **damage** to the appliance. **Should this occur the warranty to this appliance will be rendered void.**

Before connecting the gas supply to the appliance the supply should be purged to ensure no debris can enter the appliance and a gas soundness test should be performed to ensure that the existing pipe work in the property is sound.

The following diagrams show the access to the inlet gas pipe where the isolation valve will be fitted.

If the burner tray needs to be removed, **see full details on page 40.**

The gas connection should be made to the appliance by the 8mm restrictor isolation valve supplied with the appliance. This restrictor elbow is supplied loose and should be fitted as per the label on the instruction packet.

Test the operating pressure of the appliance by attaching a pressure gauge to the test point of the appliance. This connection should take place when the appliance is OFF. Ensure that gas is turned on at the gas meter. Ensure that the test point screw is not overtightened as this can damage its seal or break the assembly.

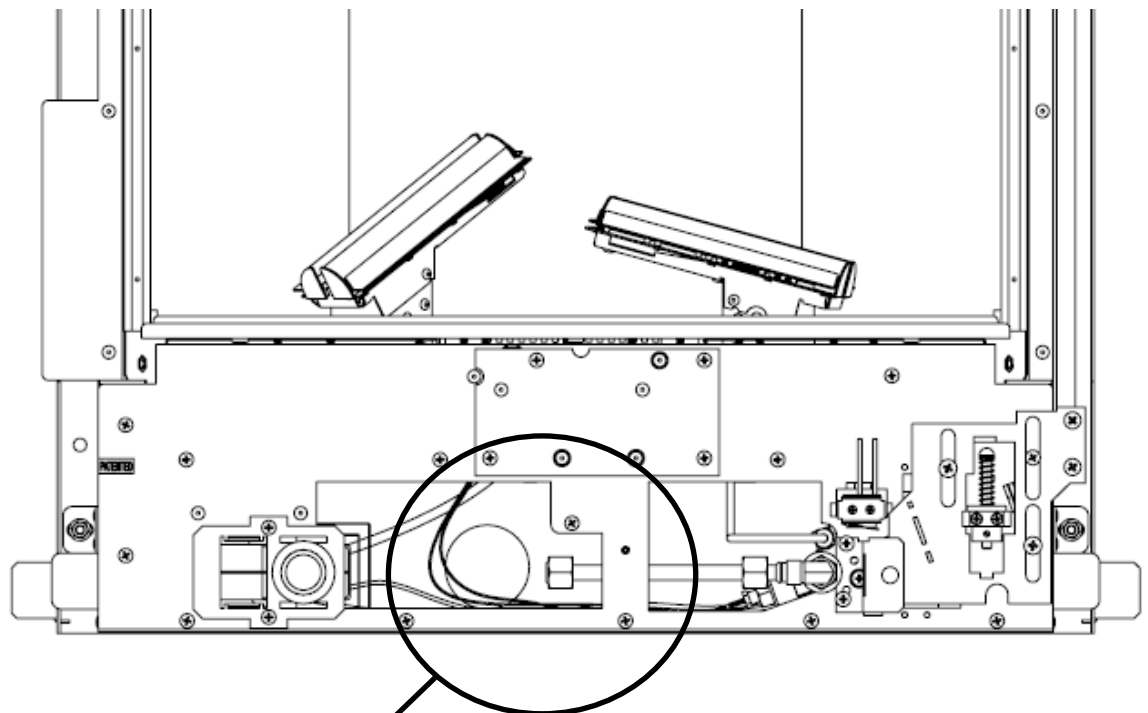

← Appliance inlet connection and rear access hole for gas supply.

Slide Lever Adjustment

4.2.1 Slide Lever Adjustment

An adjustment is provided to position the slide control lever fore and aft. This is to ensure that there is clearance behind the lever to allow it to move freely for a smooth operation.

To adjust the lever first loosen the upper and lower screws.

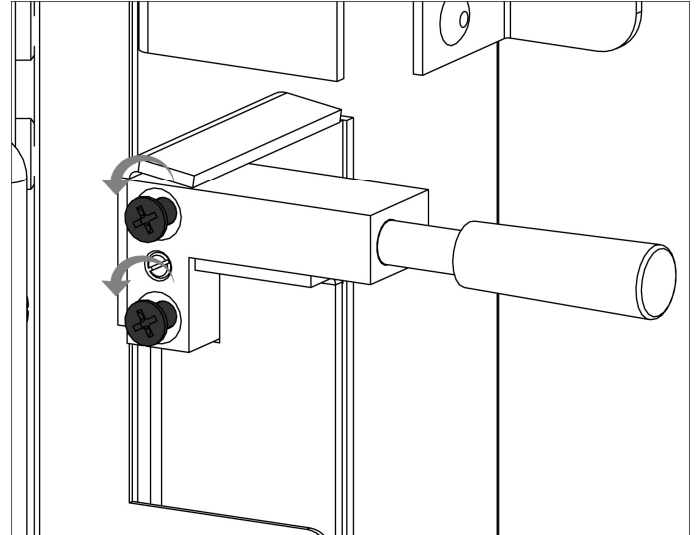

Now rotate the centre screw to reposition the lever. Winding the screw inwards will move the lever outwards and vice versa.

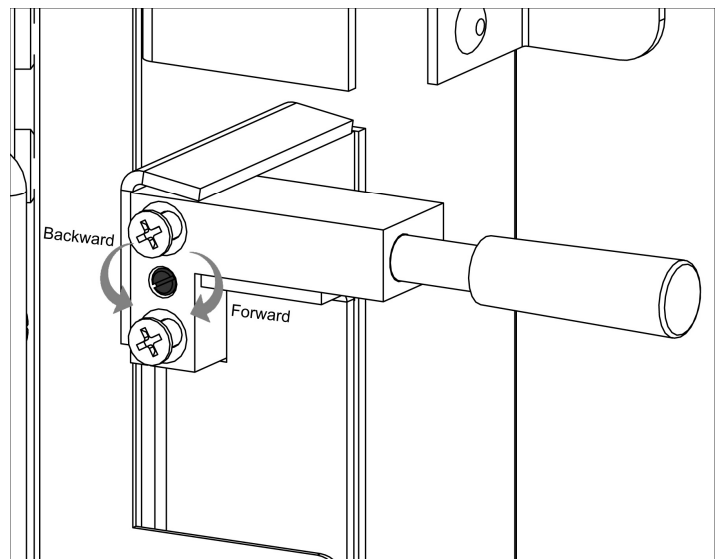

Once the lever is in the correct position, tighten the upper and lower screws to secure.

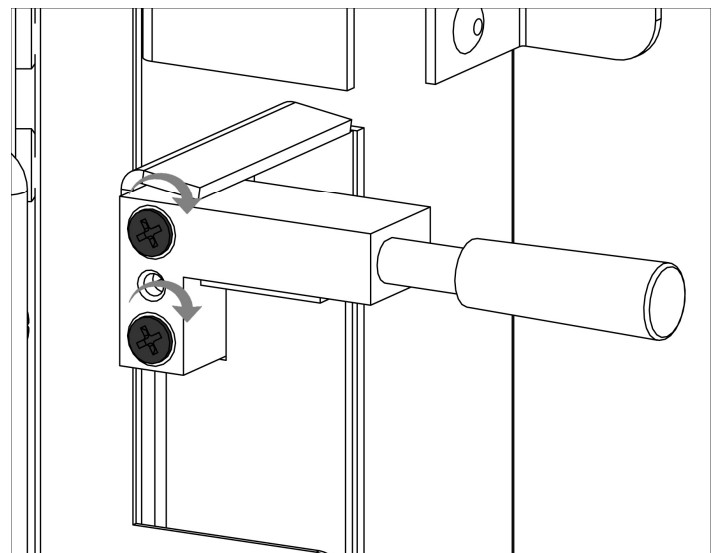

Log Setup

4.3 The following instructions detail how the ceramic fuel bed and loose components are to be installed onto the appliance. Great care should be taken when handling these ceramic parts as they are fragile and can easily be broken. Do not force any component into position, if it does not fit easily then you are not fitting the part correctly. These instructions can also be followed to remove or reinstall the fuel bed after cleaning. This is a procedure that can be undertaken by the customer as required and the frequency will be depend upon use.

See page 28 for glass panel removal and installation.

The fuel bed setup involves the installation of volcanic rock, ceramic bark, ember wire and a boxed set of ceramic decorative logs. These components will have been installed by your gas engineer at the point of installation, however it is permitted for the end user to remove clean and replace these components as necessary. The following installation instructions must be adhered to at all times.

The following diagram is for identification purposes. It is imperative that the logs are placed in the correct position for safety and also to ensure that you obtain optimal performance from your appliance.

Identify

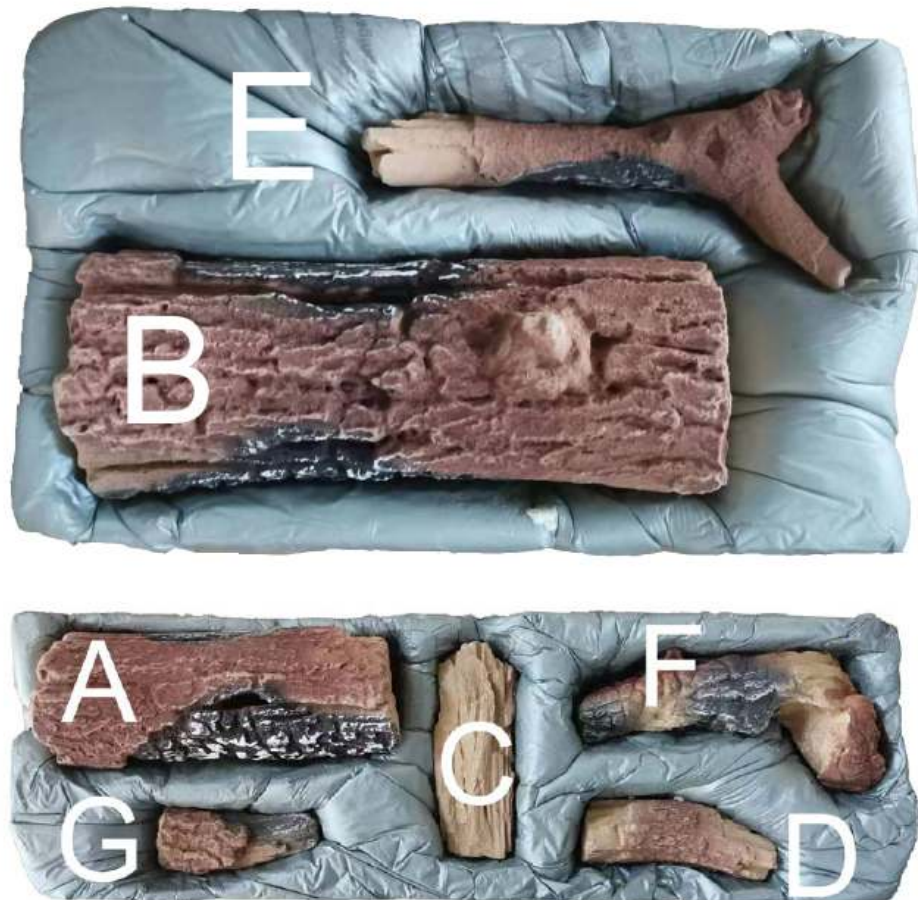

FUELBED

Place the volcanic rock on top of the centre burner as shown. Ensure a 4-5 mm gap is left between each piece. Then using **half** of the glowing ember wire supplied, ruffle between fingers to make it loose, about 20mm wide and long enough to cover the volcanic rock then align over the rock as shown. Ensure no wire is placed within 25mm of the pilot assembly. Retain the other half of the wire for replacement at annual service.



Place Log D as shown in the picture.



Place Log C as shown in the picture.



Place Log E as shown in the picture.



Place Log A as shown in the picture.



Place Log B as shown in the picture.



Place Log G as shown in the picture.



Place Log F as shown in the picture.



Lighting The Fire

4.4 Operating Instructions

This appliance is operated with slide control lever. It is located on the upper right side of the appliance.

The lever slides vertically up and down and this movement controls all functionality of the appliance, from ignition, flame control and turning the appliance off.

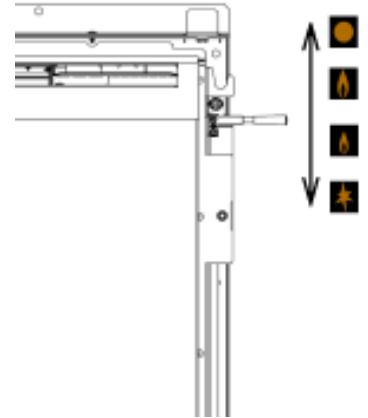

Slide the control lever downwards to the ignition symbol. After a few seconds the pilot light should light.



If the pilot light does not light, release the control knob and wait for 3 minutes before reattempting. If the pilot does not light after 3 attempts, check the battery—see page 6. If the battery is new and the pilot still fails to light, contact a gas safe engineer.



Once the pilot is lit, keep the lever pushed downwards for up to 10 seconds then release. The pilot should stay lit and the central and front log burners will now light. The appliance is now running at the LOW setting.



Slide the lever upwards, until a slight stop is felt, to turn the rear log burners on. The appliance is now running at the HIGH setting.



To turn the fire off, slide the lever upwards to the OFF symbol.



Should the spark generator fail to provide a spark at the electrode it may be that a small amount of soot has fallen from the fuel bed onto the pilot assembly, causing a short circuit. If this is the case, ensuring the appliance is off and cold, this area can be cleaned with the thin nozzle from a vacuum cleaner. See page 28 for details on glass removal to access this area.

Alternatively check the battery is in good condition—see page 6 for details.

Check for
Spillage

4.5 Spillage monitoring System (ODS Pilot)

This appliance is fitted with an atmospheric sensing system in the form of an oxygen sensing pilot burner. This is designed to shut the fire off in the event of products being spilled into the room where the fire is being operated. It is important to note that this spillage monitoring device should not be disabled or be adjusted by the installer. If the spillage monitoring device (O.D.S pilot) is replaced it must only be exchanged with a suitable component which is supplied by Hearth Products Ltd.

Check the clearance of combustion products

SPILLAGE TEST: To check for satisfactory clearance of products of combustion, close all doors and windows and leave the appliance burning on HIGH for five minutes. Insert a lit smoke match just into the gap at the top centre of the fire. It is recommended that a smoke match holder be used. All the smoke must be drawn into the flue. If spillage occurs allow a further 5 minutes and repeat the test. If spillage still occurs turn off the appliance and seek expert advice. If an extractor fan is situated in the room the spillage test should be repeated with the fan running. If there is a connecting room with an extractor fan the test should be repeated with all the doors to that room open and the extractor fan running.

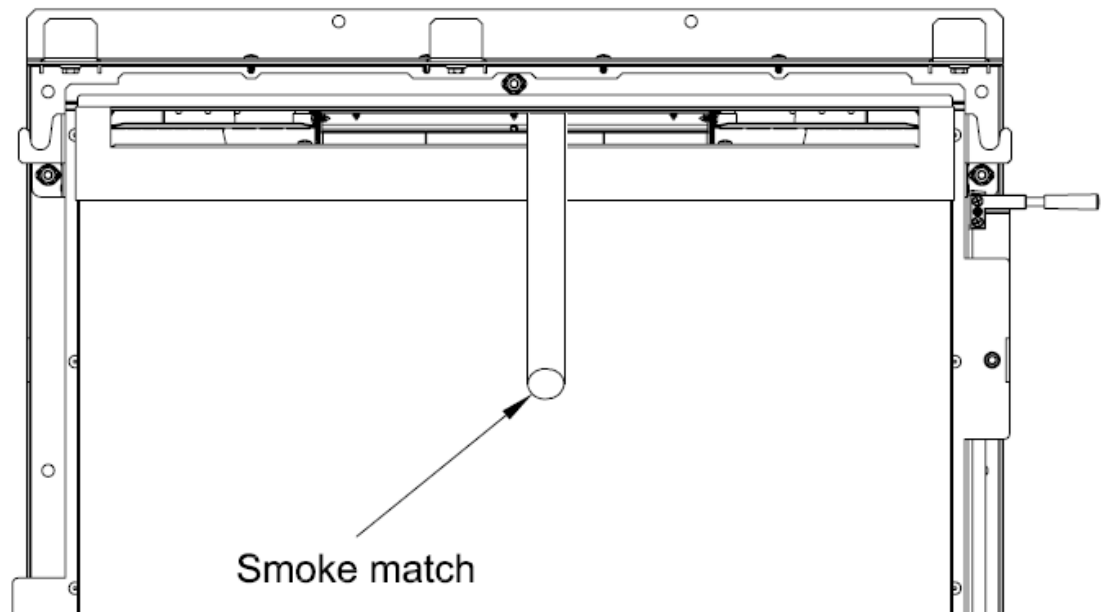

If spillage still occurs then the restrictor at the rear of the appliance can be removed to ease flow of combustion products. Once removed, repeat the test. If spillage continues to occur, ensure that there is no overhanging brickwork over the flue exit of the appliance and that the fireplace opening is well sealed.

Combustible Shelf

4.6 Combustible Shelf

This appliance may be fitted below a surround with a combustible shelf providing the following dimensional criteria is met:

There must be a minimum distance of 250mm from the top of the appliance to the underside of the shelf.

The shelf must not project more than 150mm from the mounting surface of the appliance into the room. If the shelf projects more than 150mm then the distance between the top of the appliance and the underside of the shelf must be increased accordingly; for every 10mm of projection above 150mm the distance between the fire and shelf must be increased by 25mm

Shelf Protrusion (X)	Min. Distance (Y) Between Fire and Shelf
150mm	250mm
160mm	275mm
170mm	300mm
180mm	325mm
190mm	350mm
200mm	375mm

Any combustible side wall, for example leg of timber mantel, should be a minimum of 150mm from the appliance glass panel.

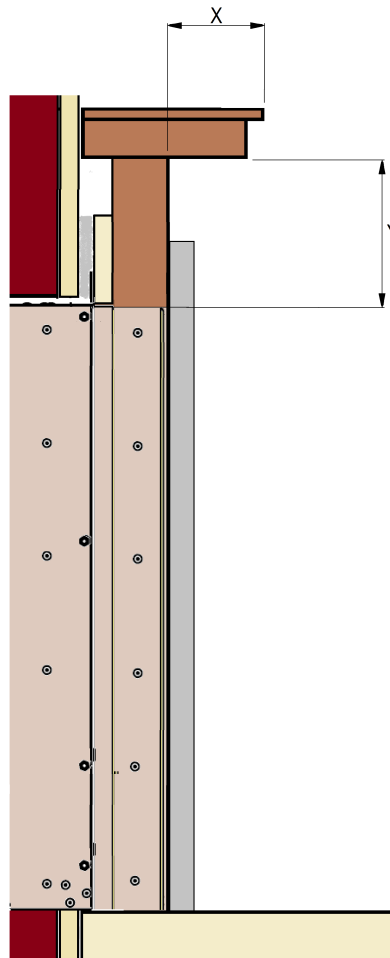

Complete the
Installation

4.7 INFORM THE CUSTOMER OF THE FOLLOWING TO COMPLETE THE INSTALLATION

Demonstrate the lighting of the appliance and the controls to control the heat settings. Demonstrate how to turn the fire off.

Demonstrate the removal of the trim and how to reinstall correctly.

Discuss the removal and reinstallation of the glass panel and the ceramics. Explain how they should be cleaned and make the customer aware of the health and safety warning detailed later in these instructions.

Explain to the customer that the ceramics are fragile and must be treated with great care, explain that the ceramics are not covered by the warranty because of their fragility. Also explain that small hairline cracks will appear in the surface of the ceramics due to heat expansion and contraction—this is perfectly normal.

During the first several hours of use an odour will be experienced—this is normal and is the starch oils and paints used in the manufacturing process. This odour is non toxic and will eventually disappear with use.

Advise the customer that ALL glass fronted gas appliances will leave condensation on the inside face of the glass when first lit—this is perfectly normal and is a result of the water vapour present in the combustion products hitting the cold glass surface. This condensate will disappear over the next minute or so. It is also important to advise the customer that this condensate will carry with it any **impurities in the air** and will therefore, with use, leave a **slight grey condensation mark** on the inside of the glass. We advise that this is cleaned off maybe 2 to 3 times a year, dependant on use.

Advise that no rubbish should be thrown onto the appliance and that the appliance should be cleaned regularly.

Advise the customer that the appliance should be serviced annually by a gas safe engineer to ensure the safety and integrity of the appliance.

Advise the customer that the appliance has a naked flame and therefore it is essential that a suitable fireguard be used for the protection of the elderly, infirm and young children. This fireguard should conform to BS8423 : 2002 (Fireguards or use with Gas Heating Appliances).

These instructions and all supplied installation tools must be handed over to the customer once installation is complete.

Servicing

5.0 Servicing the Appliance.

The following procedures can and should **only** be performed by a **Gas Safe registered installer**.

This appliance should be serviced annually by a **Gas Safe registered installer**.



5.1 Removal of the burner tray.

The removal and replacement of all the gas carrying components will require the removal of the burner tray. The following information details the removal of this tray. Once removed, refer to the relevant section that follows detailing the removal of the specific component (s).

- Turn off the gas supply at the isolation valve on the appliance. Ensure the appliance is cold.
- Remove the glass door. See page 28.
- Remove the fuel effect components - put in a suitable location where they cannot be damaged.
- Disconnect the gas supply from the restrictor elbow.
- Remove the screws securing the burner tray to the firebox .
- Re-assemble the tray in the reverse order.

The following diagrams demonstrate the removal of the tray.

Remove the 10 screws securing the burner tray to the firebox—highlighted below.

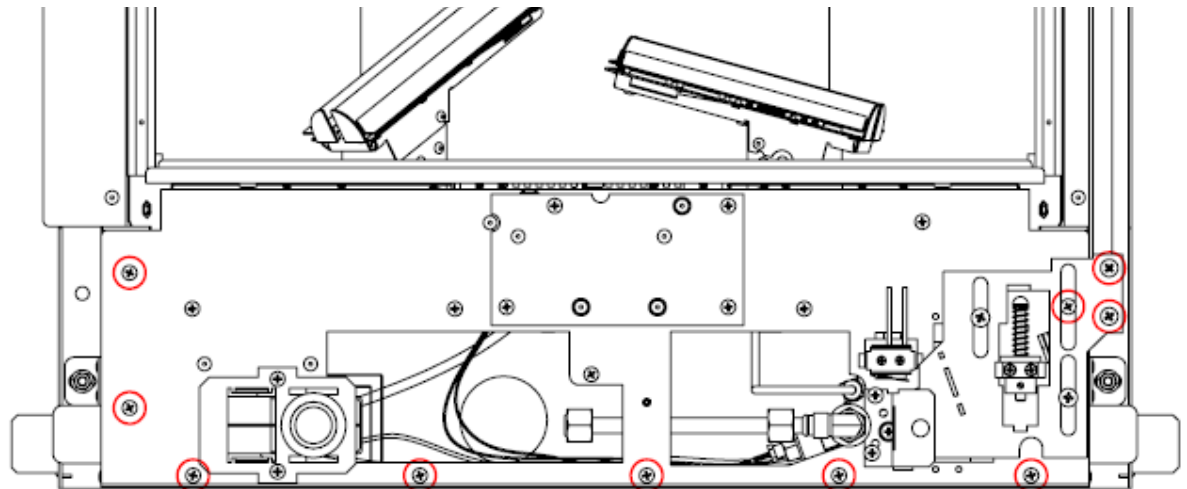

Remove the 4 screws securing the burner tray top panel to the firebox—highlighted below.

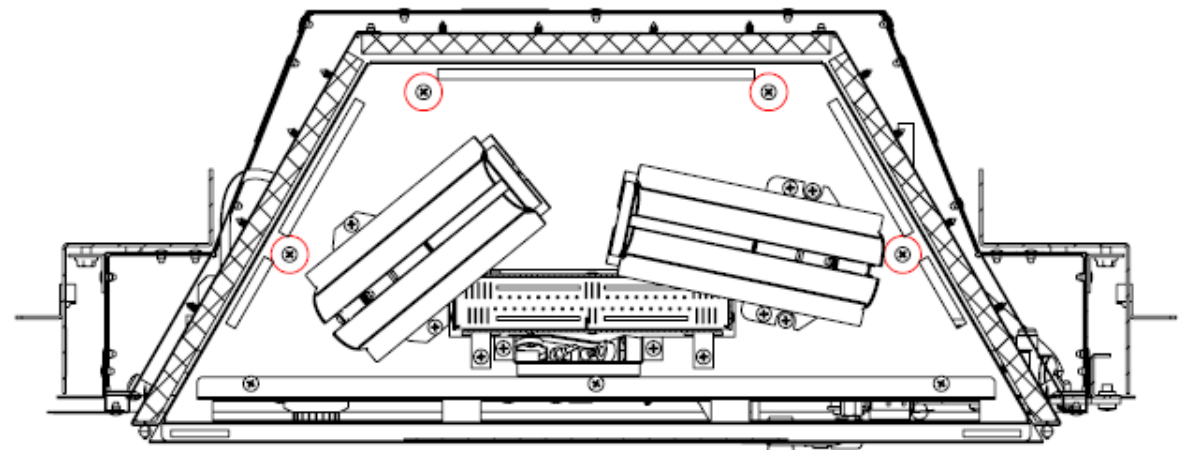

5.2 Remove of Slide Gas Valve.

The slide valve can be removed without removing the burner tray.

Remove the nut highlighted below from the slide gas valve.

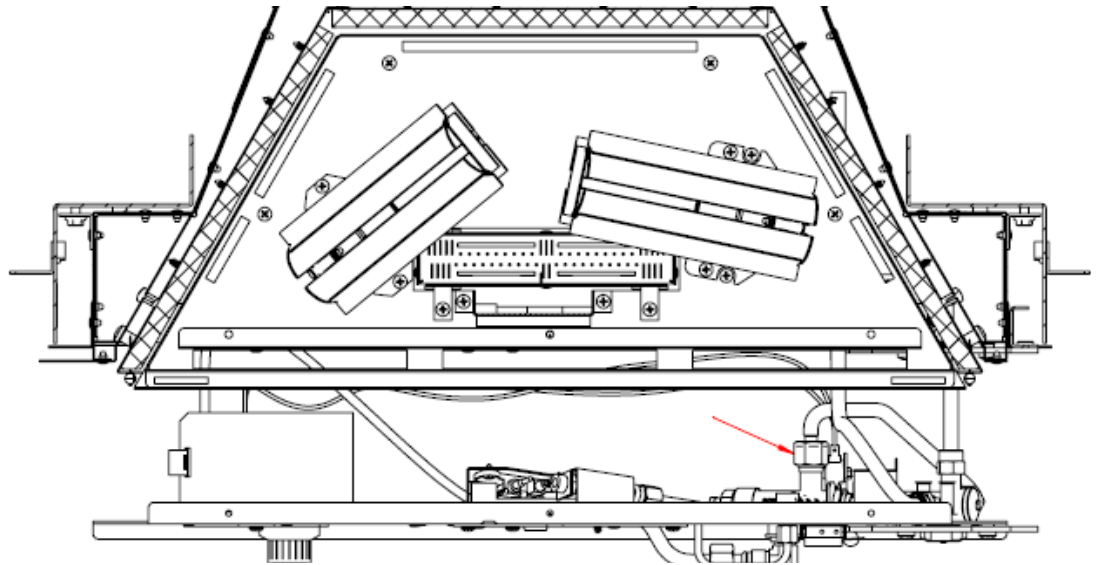

Release the inlet gas inlet nut, pilot outlet nut and thermocouple nut from the gas valve. Now remove the 2 screws highlighted that sit within stainless guide plate —highlighted below. The slide valve can now be removed.

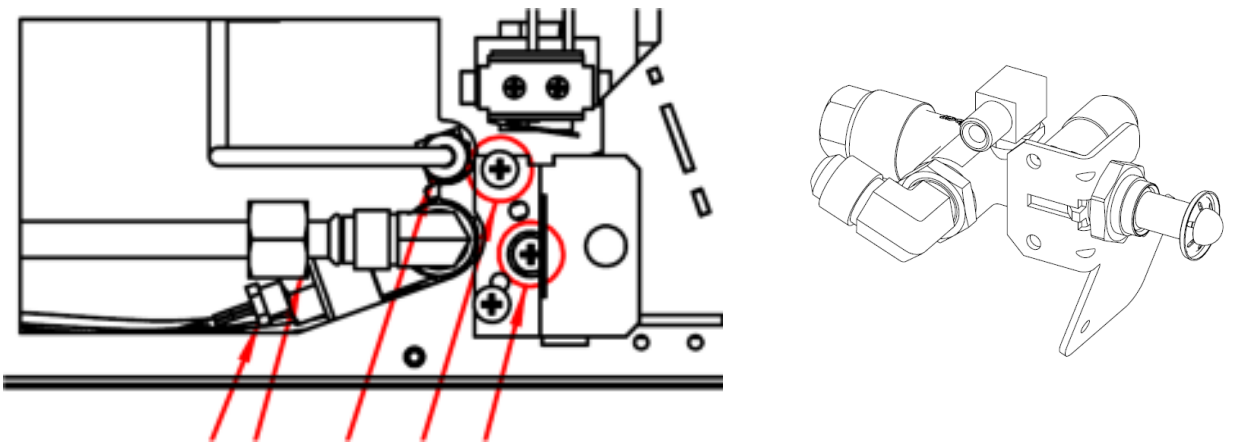

Ensure on refitting the valve that the circlip washer on the actuating button sits correctly between the lever pressure plate and the release guide plate.

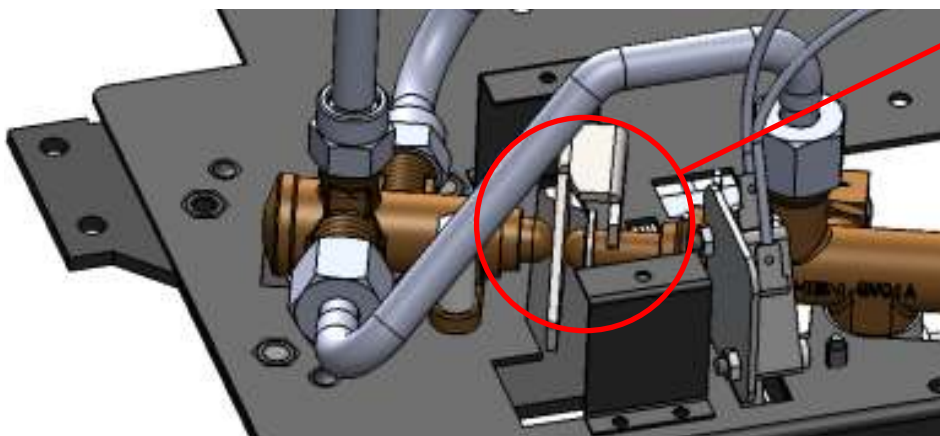

Ensure on refitting the valve that the circlip washer on the actuating button sits correctly between the lever pressure plate and the release guide plate.

5.3 Remove of the pilot assembly.

Remove the 4 screws highlighted in the diagram below.

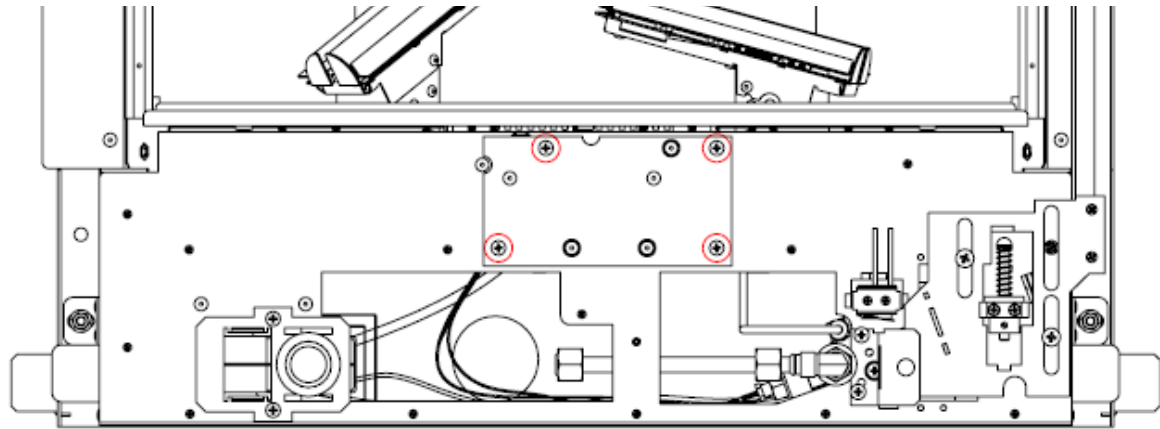

Release the pilot nut from the inlet of the pilot assembly and the thermocouple nut from the slide gas valve. Now remove the 2 small screws securing the microswitch (noting its orientation) and the two screws holding the pilot assembly to the burner tray. The pilot can now be removed. Original replacement parts can only be obtained through Hearth Products Ltd.

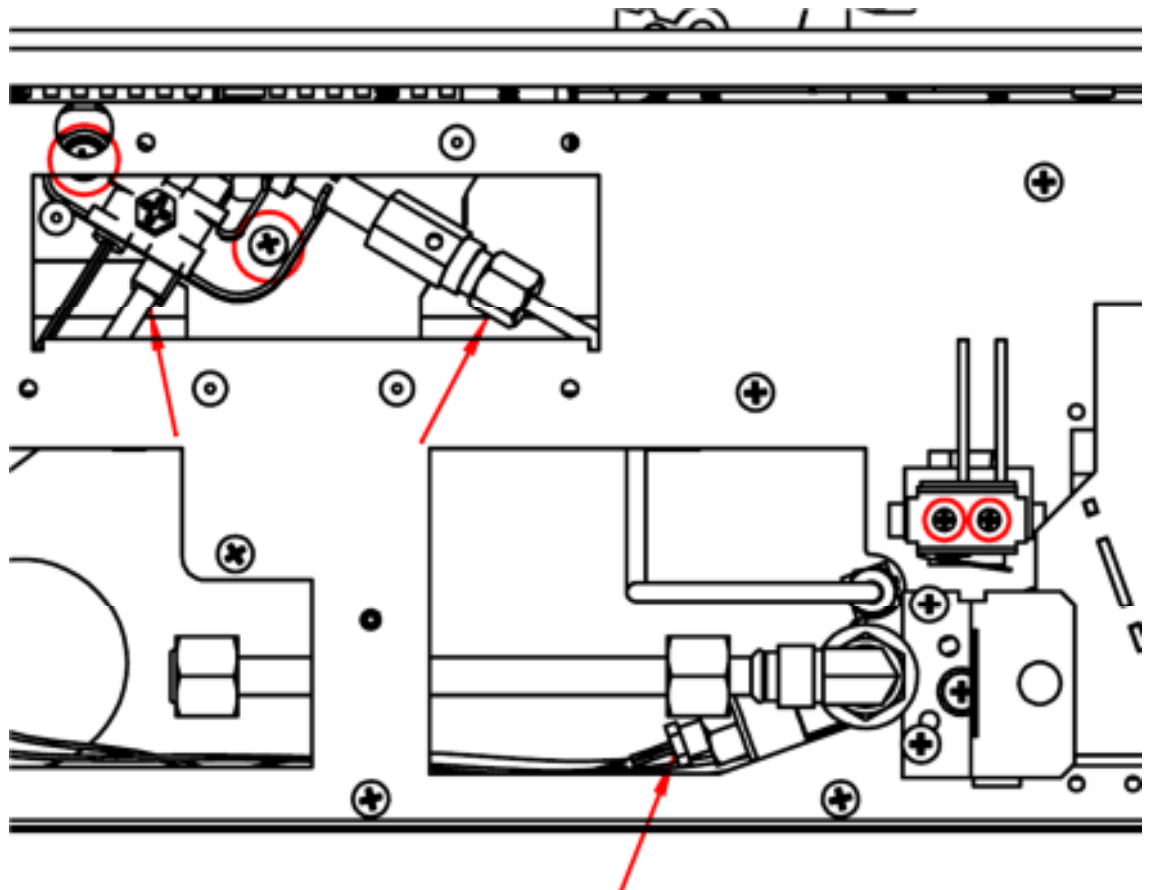

5.4 Remove of spark generator.

Remove the 2 screws to release the igniter and its support bracket. Unscrew the battery cap, remove the battery and remove the securing nut. The igniter can then be removed from its bracket. Transfer the wires from the rear of the igniter to the new igniter and re-assemble in reverse order.

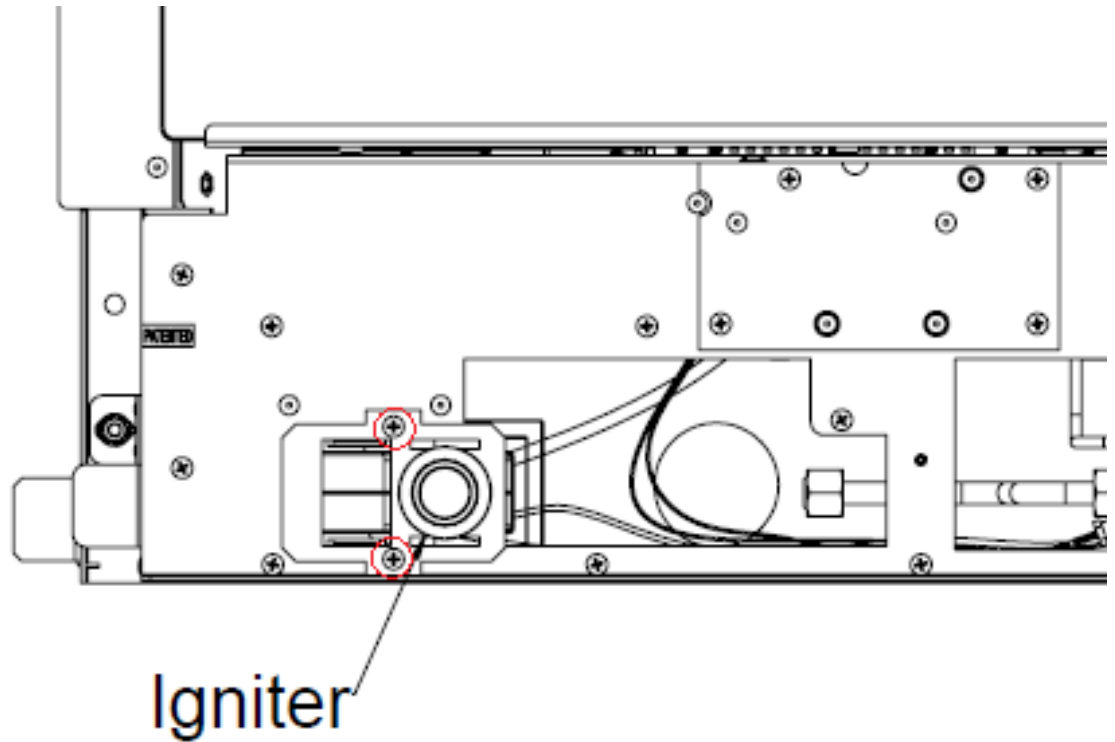

5.5 Removal of Tee valve (High Setting).

Remove the 14 screws shown highlighted in the diagram below.

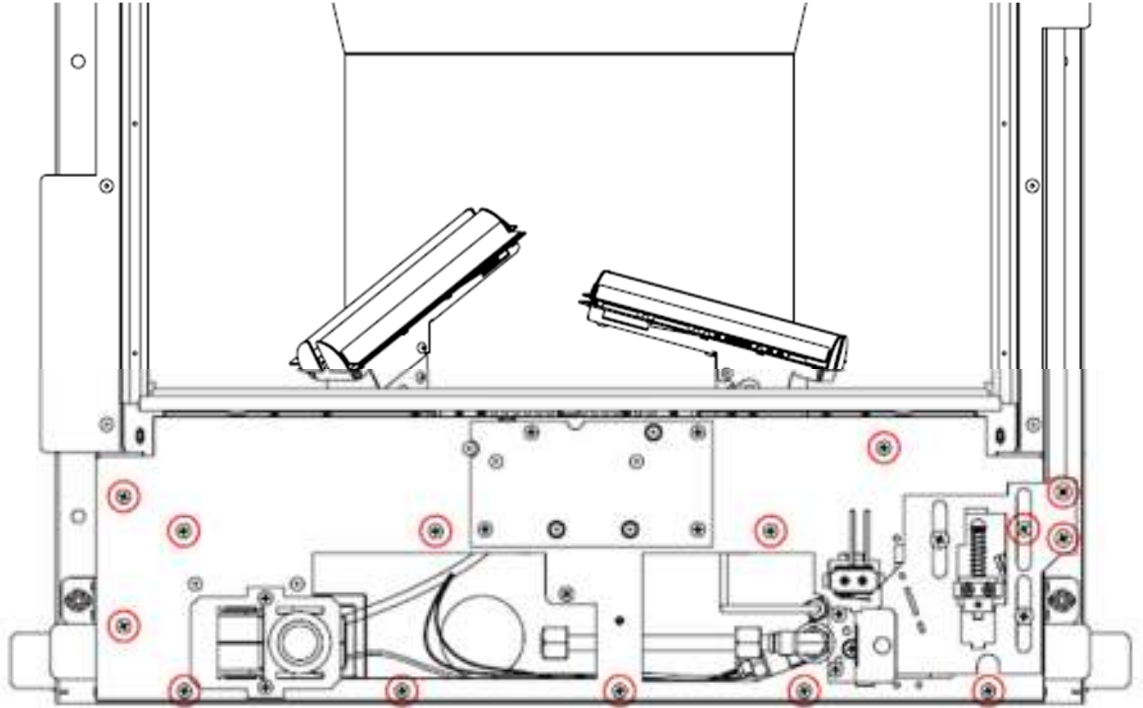

Remove the 3 screws shown highlighted in the diagram below and the burner tray can be removed.

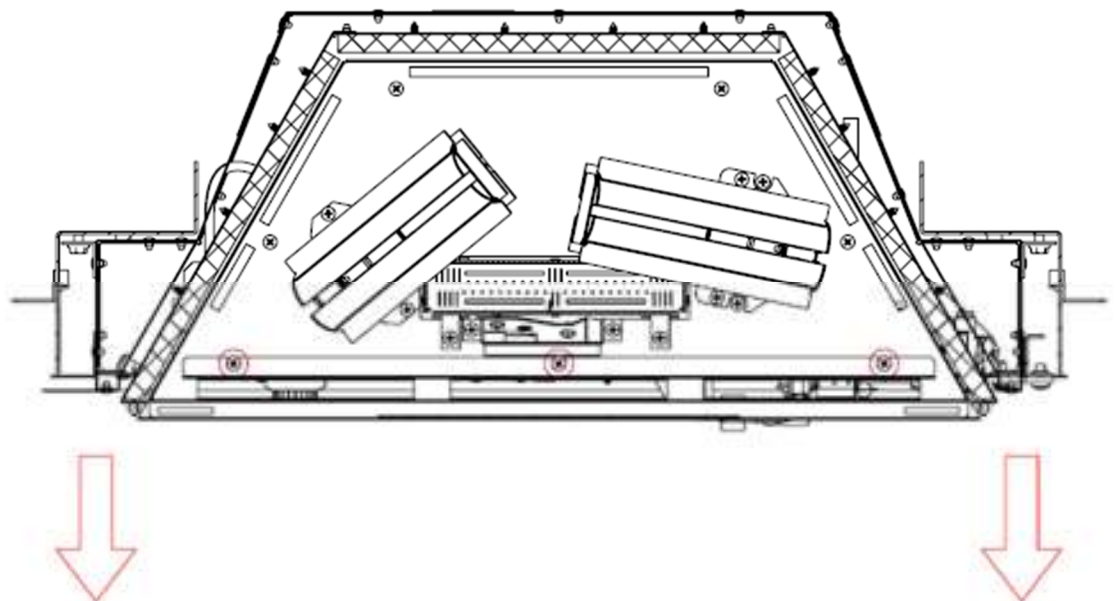

5.5 Removal of Tee valve (High Setting).

Remove the 2 nuts from the tee valve, highlighted in the diagram below.

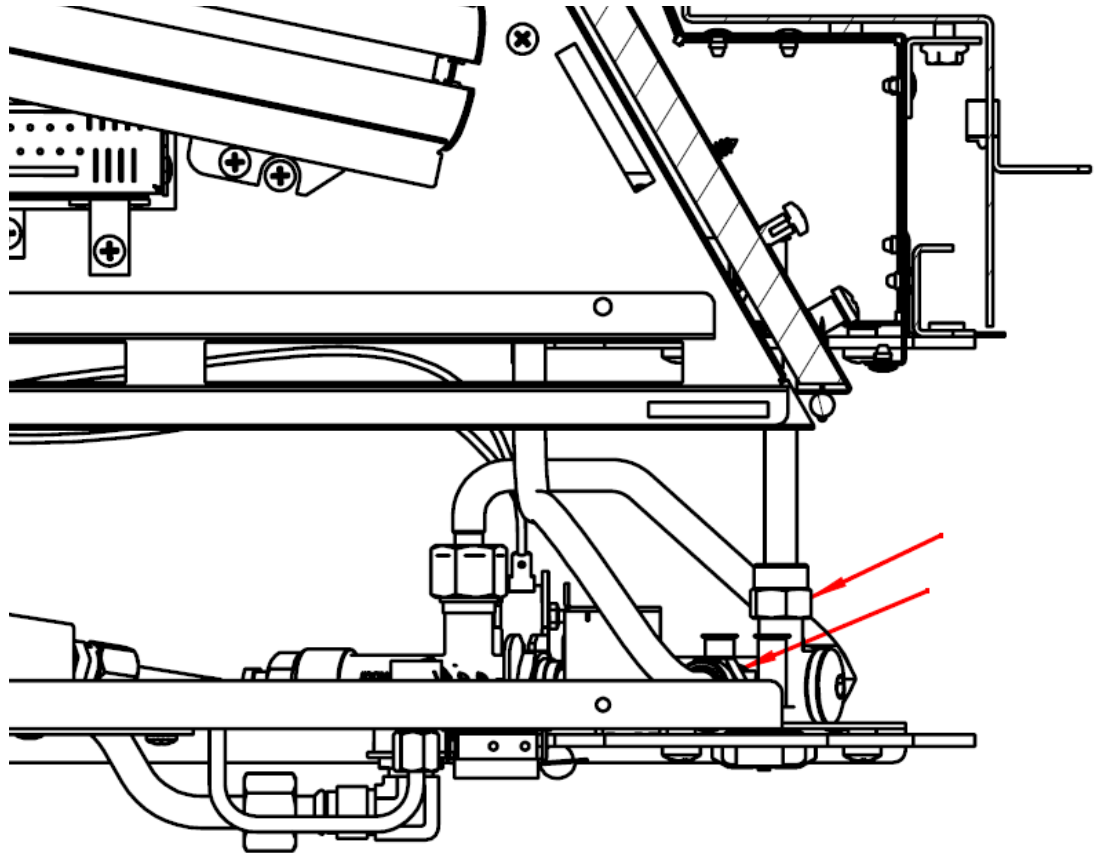

Remove the gas inlet nut as shown below, then finally remove the two fastening nuts to release the tee valve from the burner tray.

Reassemble in reverse order.

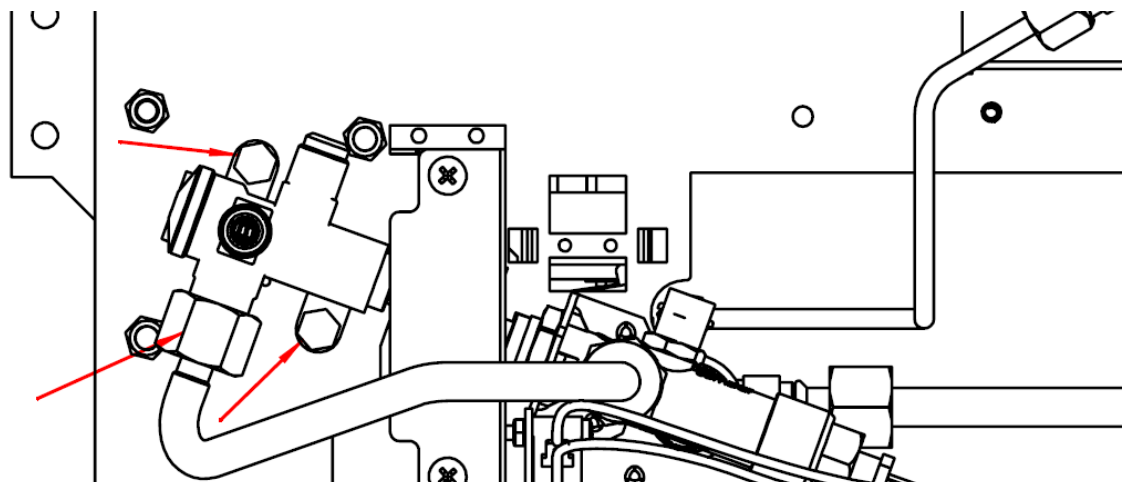

5.6 Removal of Injectors

Remove the 4 as shown in the diagram. The two raised burners can now be removed.

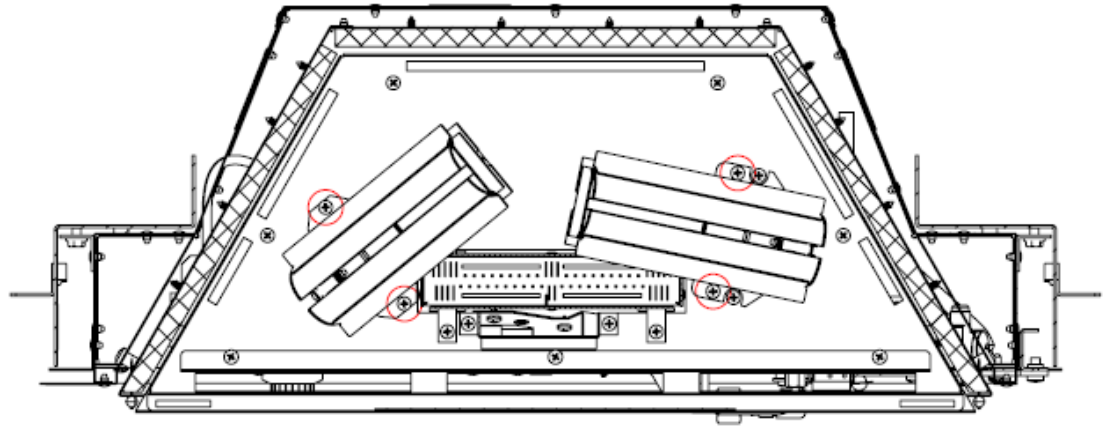

Remove the 4 as shown in the diagram. The centre burner can now be removed.

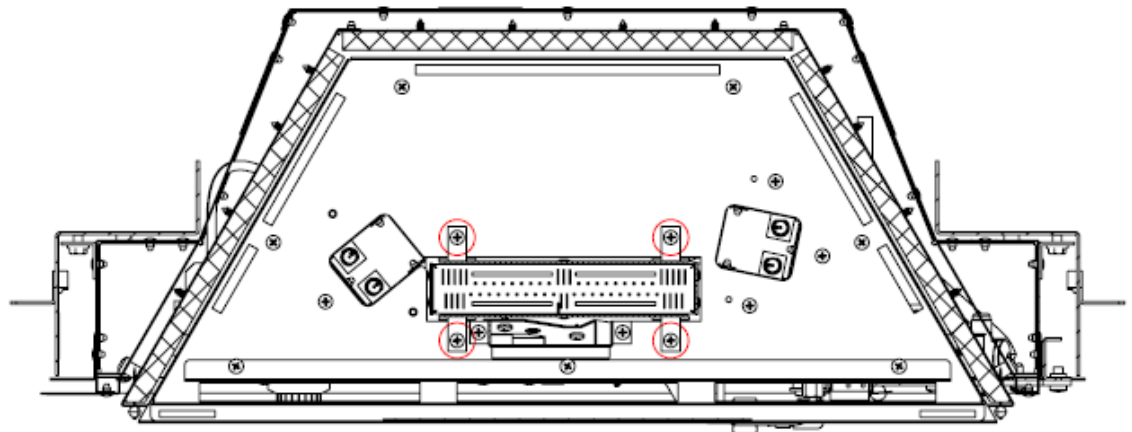

The 5 injectors can now be accessed. Take great care to ensure these injectors are not mixed. The appliance will not perform correctly if the injectors are replaced in incorrect positions.

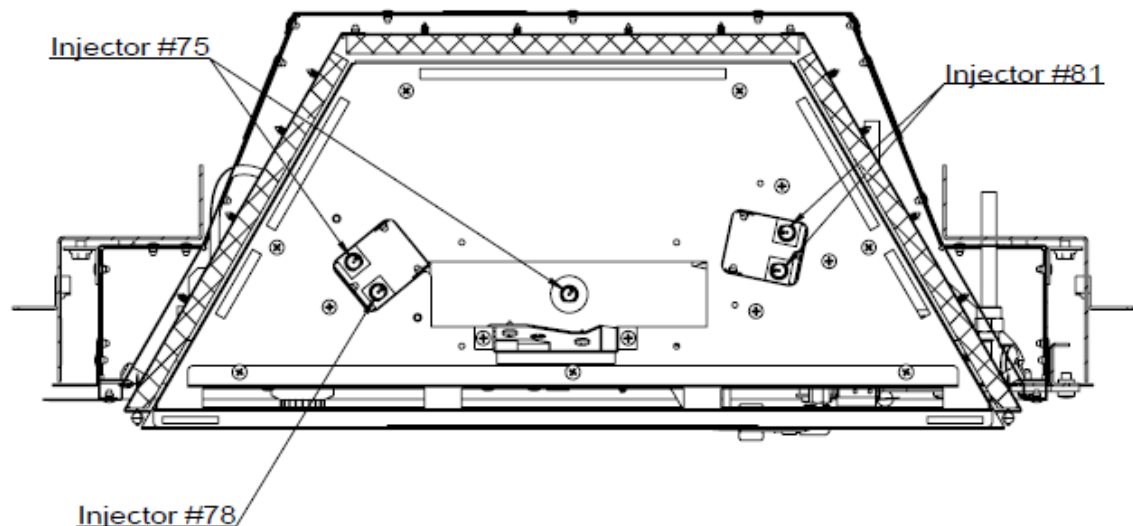

5.7 Removal of Fibre Lining Panels

Remove the 8 pins in the diagram below.

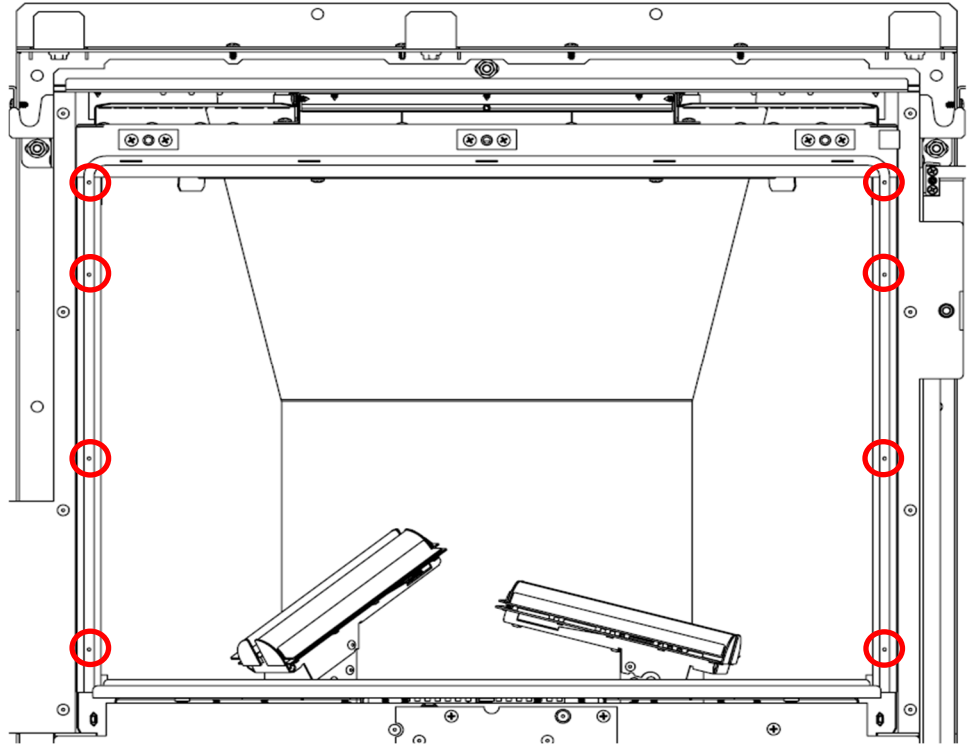

Then remove the 2 screws and retaining brackets shown in these diagrams. This will release the two side ceramic boards, which in turn will release the rear boards for replacement.

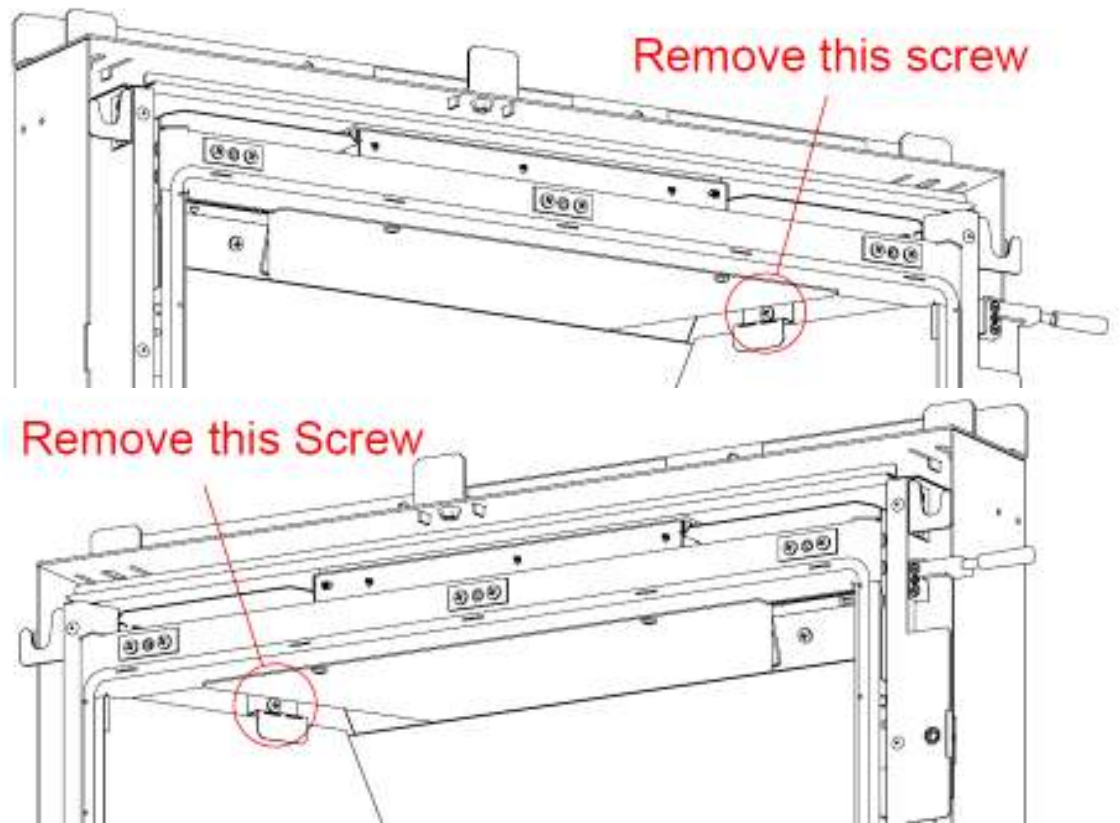

5.8 Removal and replacement of a glass clamp retaining threaded boss.

Should the thread become damaged in one or more of the glass clamp retaining features, it is possible to replace this part. The three threaded bosses are shown in the diagram below.

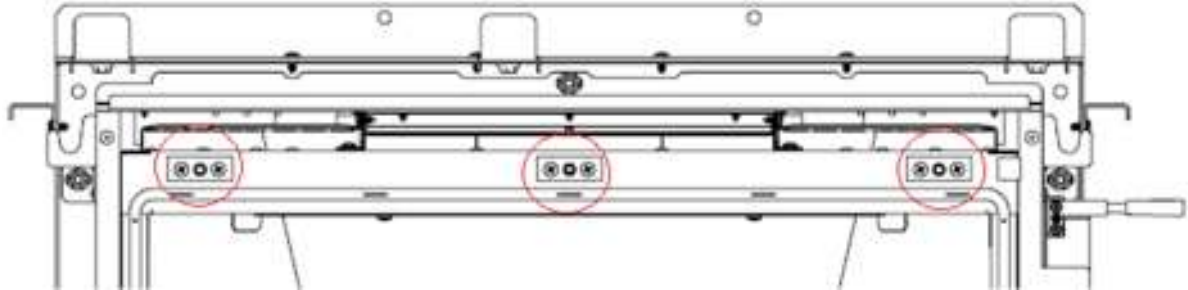

Remove the two screws shown in the diagram, remove the thread assembly and replace with new component. This part can only be purchased from Hearth Products Ltd.

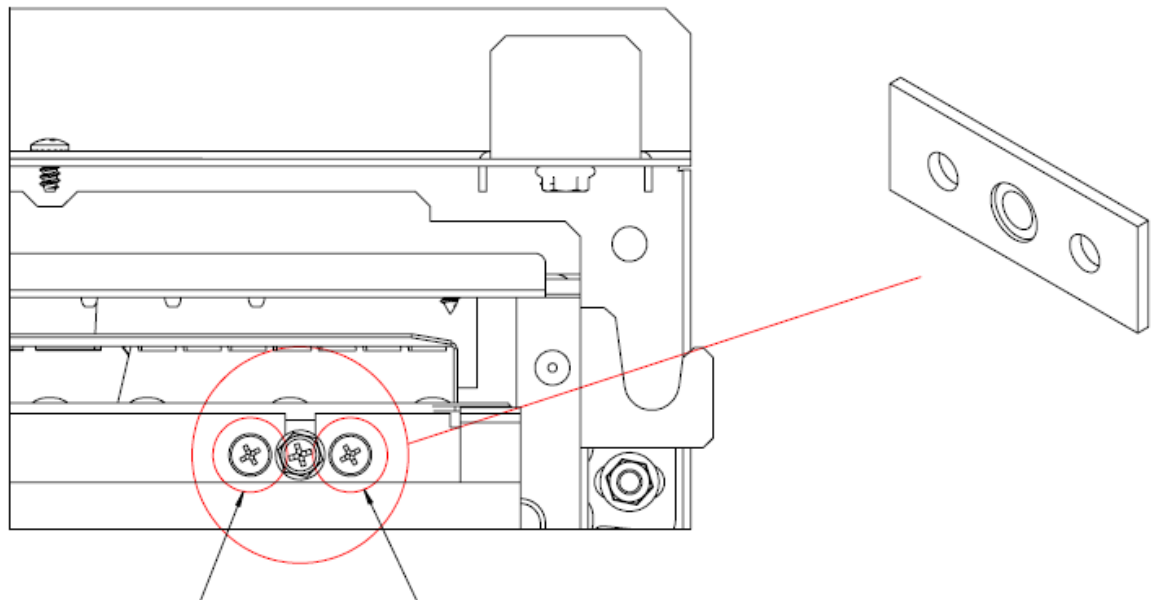

6.0 Record of annual services

The extended warranty of the specified components within this appliance is conditional on the annual service of the appliance by a Gas Safe registered engineer. Failure to maintain the product or to use the product in a way which is not intended will void the manufacturer's warranty.

Ensure a record is kept of the annual services conducted by the Gas Safe engineer in the table below.

Service of this appliance must only be conducted by a Gas Safe registered engineer.



Annual Service Record

YEAR 1	Gas Safe Engineer Name:	
	Gas Safe Engineer Registration No.:	
	Date of annual service:	
YEAR 2	Gas Safe Engineer Name:	
	Gas Safe Engineer Registration No.:	
	Date of annual service:	
YEAR 3	Gas Safe Engineer Name:	
	Gas Safe Engineer Registration No.:	
	Date of annual service:	
YEAR 4	Gas Safe Engineer Name:	
	Gas Safe Engineer Registration No.:	
	Date of annual service:	

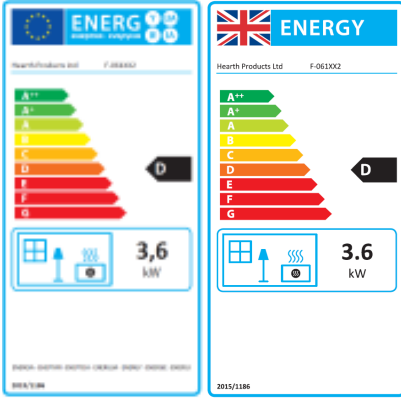

Product Fiche	
Manufacturer :	Hearth Products Ltd
Model No.	F-061XX2
Fuel Type	Natural Gas I _{2H}
Energy Efficiency Class	D
Indirect Heating Functionality	No
Direct Heat Output kW	3.6kW
Indirect Heat Output kW	N/A
EEl	75.9%
Useful Energy Efficiency (NCV)	High : 84.9%
Useful Energy Efficiency (NCV)	N/A
Nominal Heat Output	High : 3.6kW
Nominal Heat Output	Low : 2.1kW
Heat Output Temperature Control	Two Manual Stages
Permanent Pilot Power (kW)	N/A
Space Heating Emissions NO _x (GCV)	130mg/kWh

7.0 Important Note:

The energy efficiency class of this product is defined using a seasonal efficiency calculation which reduces the actual net efficiency of the product where the use of automated heat control, thermostats, window open sensors and timers are not used. This is not to be confused with the net efficiency, or useful efficiency of the appliance (shown in the tables above).

**This product MUST be installed by a Gas Safe Registered Installer. Full details are provided in this manual.
Hearth Products Ltd. Unit 14 Tollgate Industrial Estate, Stafford, ST16 3SU**

This page is intentionally left blank

User Replaceable Parts

Part Number	Description
P-XX11731	Ravel 550 Ceramic Log Set
P-XX1212A	Volcanic Rock Pack
P-XX1213	Ceramic Bark Pack
P-XX1234	Ember Wire Pack
P-XX1390	Glass Panel

To order spare parts for your appliance visit www.hplsupport.co.uk or call us directly on 01785 225401

It is important to note that the above spares are user serviceable components that can be changed by the customer. The spares shop also features other components which may have to be installed by a Gas Safe engineer. If in doubt please contact us directly.



Hearth Products Ltd
Unit 14 Tollgate Industrial Estate,
Stafford, ST16 3SU

www.hearthproducts.co.uk

Tel: 01785 225401 Fax: 01785 225501

Email: info@hearthproducts.co.uk



Due to our policy of continual product improvement, some diagrams and small details may not be accurate however if there is any concern or matter of understanding that you feel needs to be clarified please contact us directly. Our contact details are shown below.