



ELECTROTHERM FURNACES

INDIA'S BEST : GLOBALLY ADMIRERD

Induction Furnace



Metal Refining Konverter



Ladle Refining Furnace



Continuous Casting Machine





ELECTROTHERM

Conference on Indian Steel Quality Standards
12th July, 2019

Quality Steel Production through Integrated Induction Steel Plants

**- Dr. Swarn Bedarkar
Electrotherm (India) Limited**



ELECTROTHERM

Various routes of steelmaking in INDIA

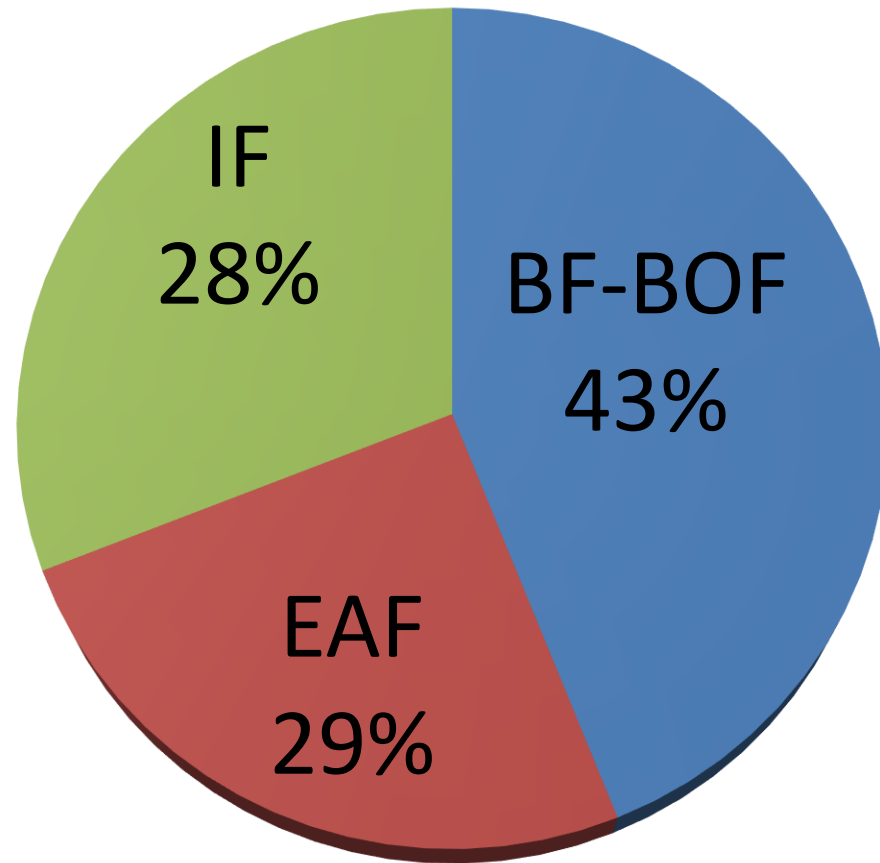



ELECTROTHERM

Quality of Steel

- Quality of steel is summation of how well steel meets its
 - specified chemistry
 - mechanical properties
 - cleanliness
- The quality is specified to determine the ability of steel to perform its designed function.



Types of steels

- Construction grade steel
- Low alloy steel
- High alloy steel
- Stainless steel



ELECTROTHERM

Construction grade TMT bars IS 1786

<i>Constituent</i>	<i>Percent, Maximum</i>						
	Fe 415	Fe 415D	Fe 500	Fe 500D	Fe 550	Fe 550D	Fe 600
Carbon	0.30	0.25	0.30	0.25	0.30	0.25	0.30
Sulphur	0.060	0.045	0.055	0.040	0.055	0.040	0.040
Phosphorus	0.060	0.045	0.055	0.040	0.050	0.040	0.040
Sulphur and phosphorus	0.110	0.085	0.105	0.075	0.100	0.075	0.075



ELECTROTHERM

Integrated Steel Plants



ELECTROTHERM

Integrated Steel Plants

- The plant which has facilities of conversion from iron ore to steel is called integrated steel plant
- The facilities may include
 - Beneficiation, pelletization, sintering
 - Production of hot metal / pig iron
 - Sponge iron making
 - Steelmaking
 - Steel refining
 - Steel casting
 - Rolling mill



ELECTROTHERM

Various routes of steel making

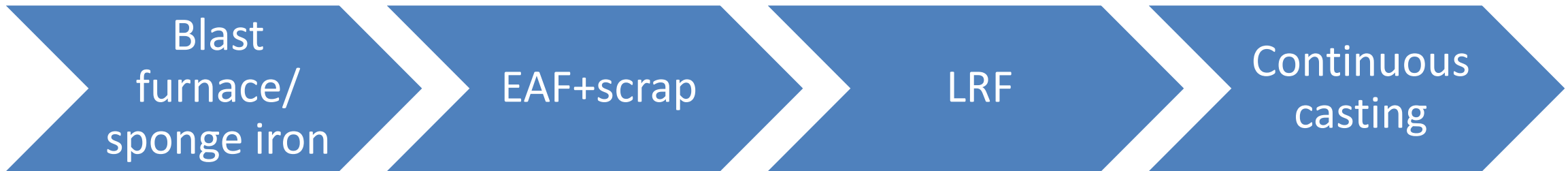
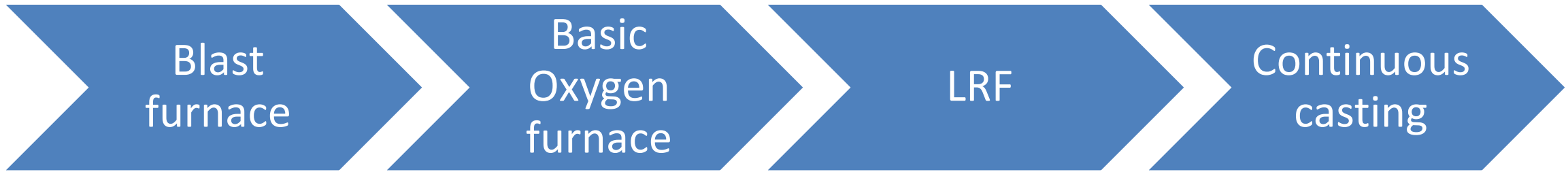



ELECTROTHERM

BF – Converter combination

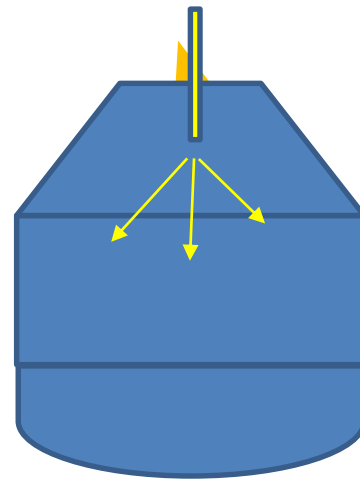
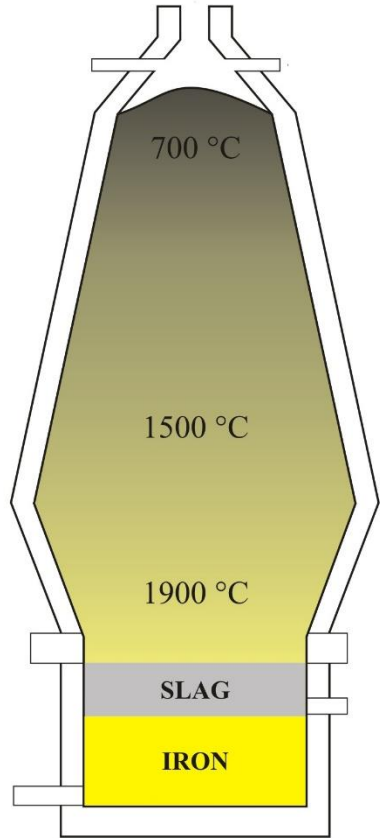

Converter

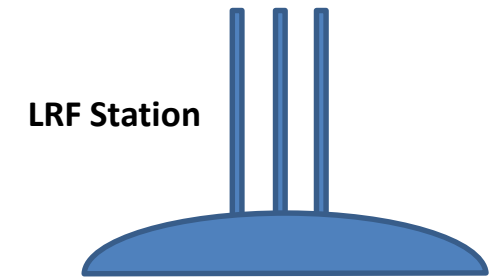

LRF Station



CCM



ELECTROTHERM

EAF steelmaking route

Sponge iron / pig iron / scrap

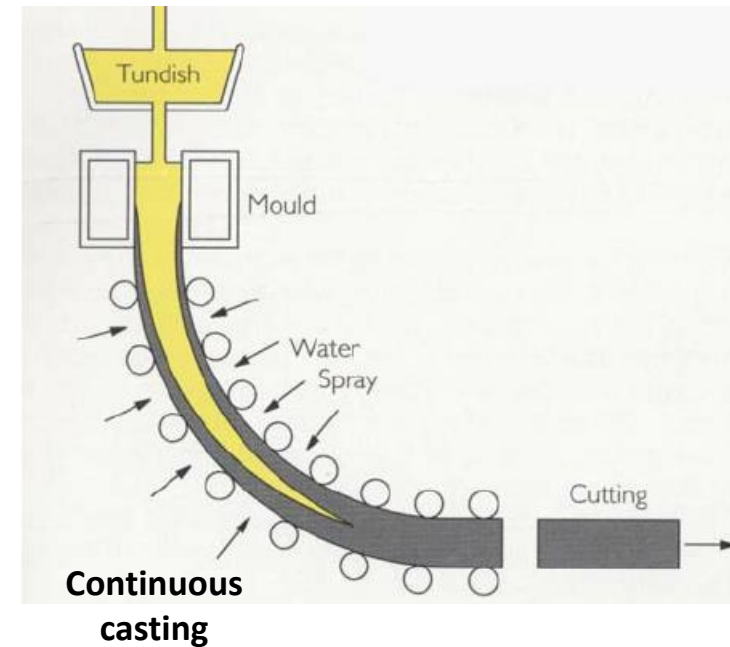
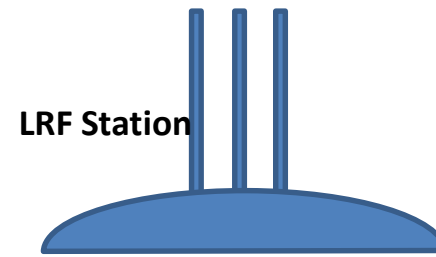
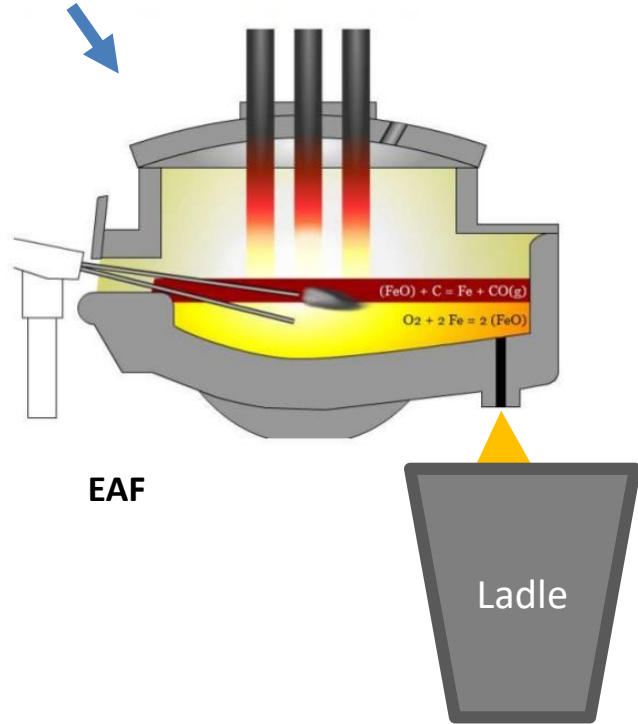



ELECTROTHERM

**INTEGRATED INDUCTION FURNACE BASED
STEEL PLANTS**



ELECTROTHERM

Ordinary Induction Furnace based steel plants

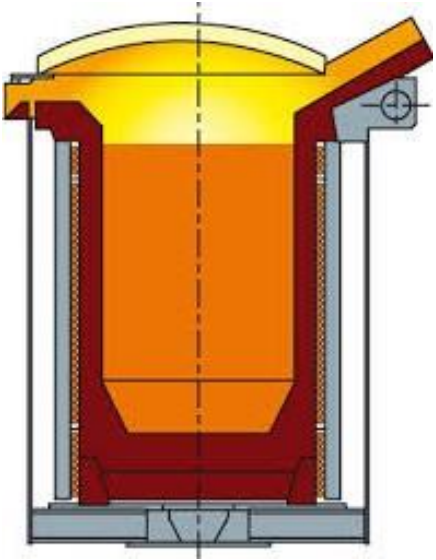

Induction Furnace

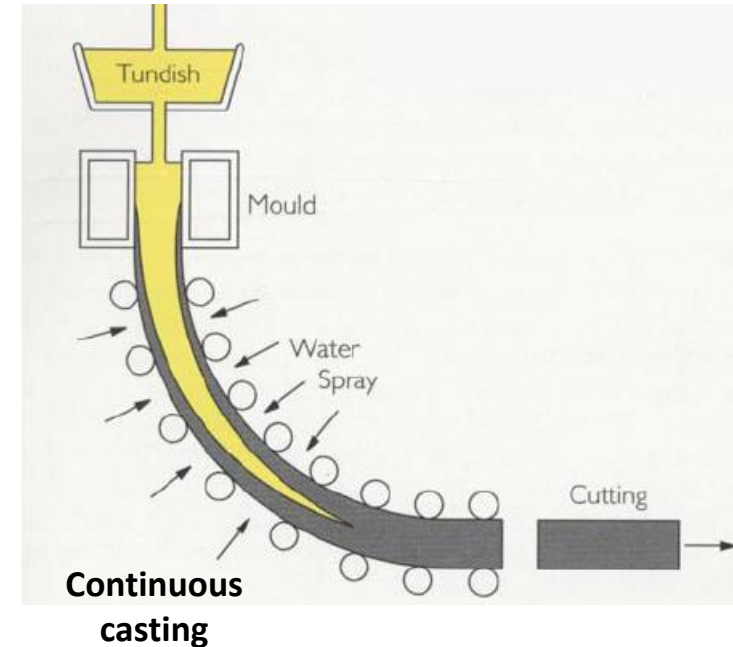

Continuous casting



ELECTROTHERM

Integrated induction steel plants

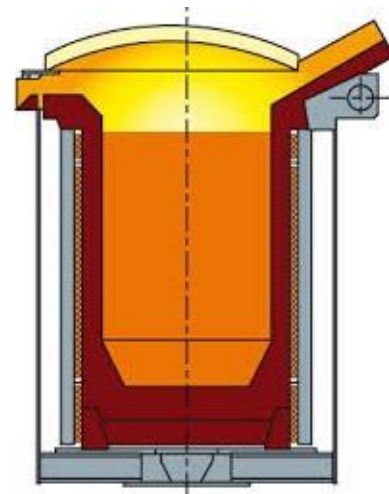
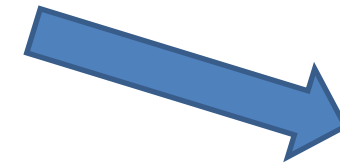
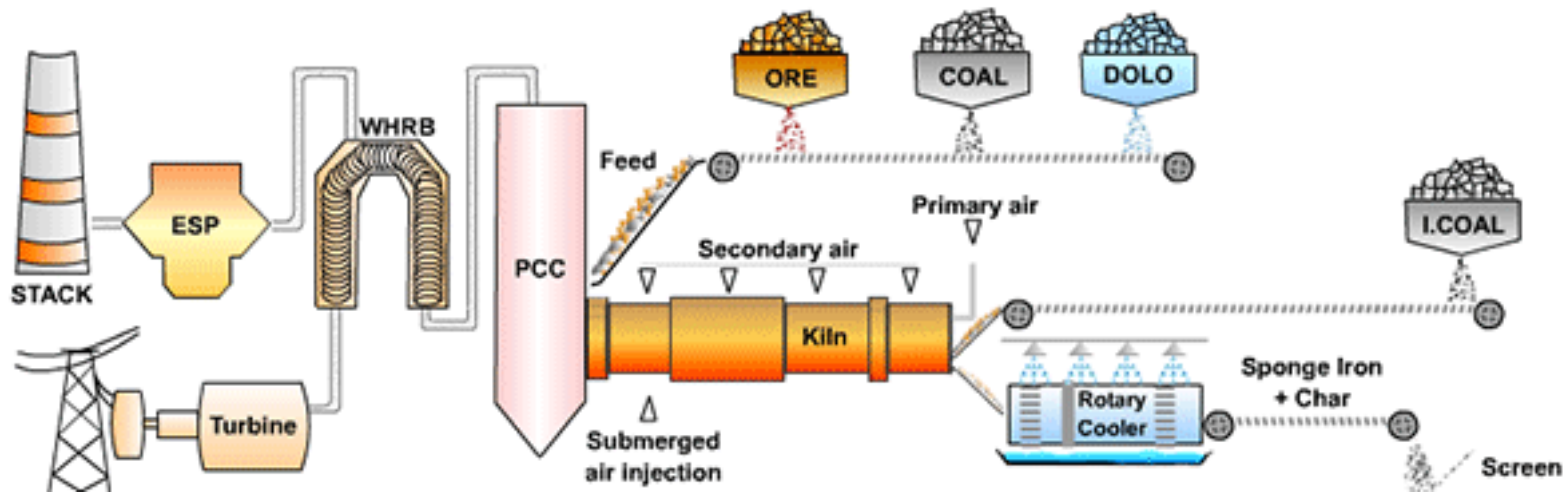



ELECTROTHERM

Integrated induction steel plants

Sponge iron
+ pig iron

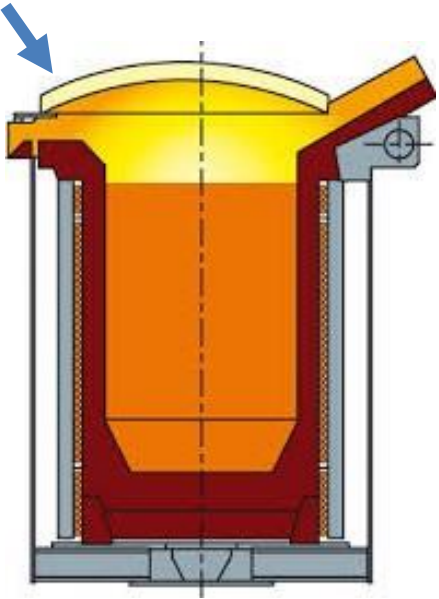

Induction Furnace



LF Station

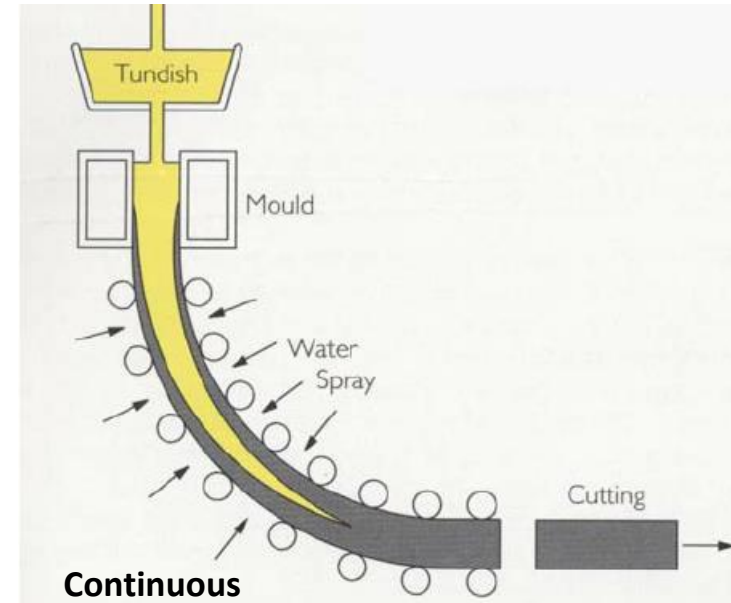
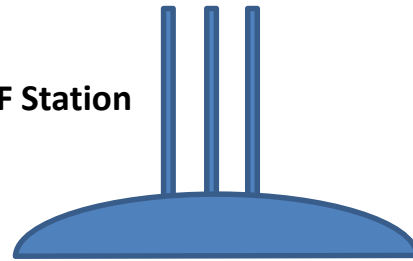

Continuous casting



ELECTROTHERM

ELdFOS™ Technology



ELECTROTHERM

Melting in induction furnace and tapping

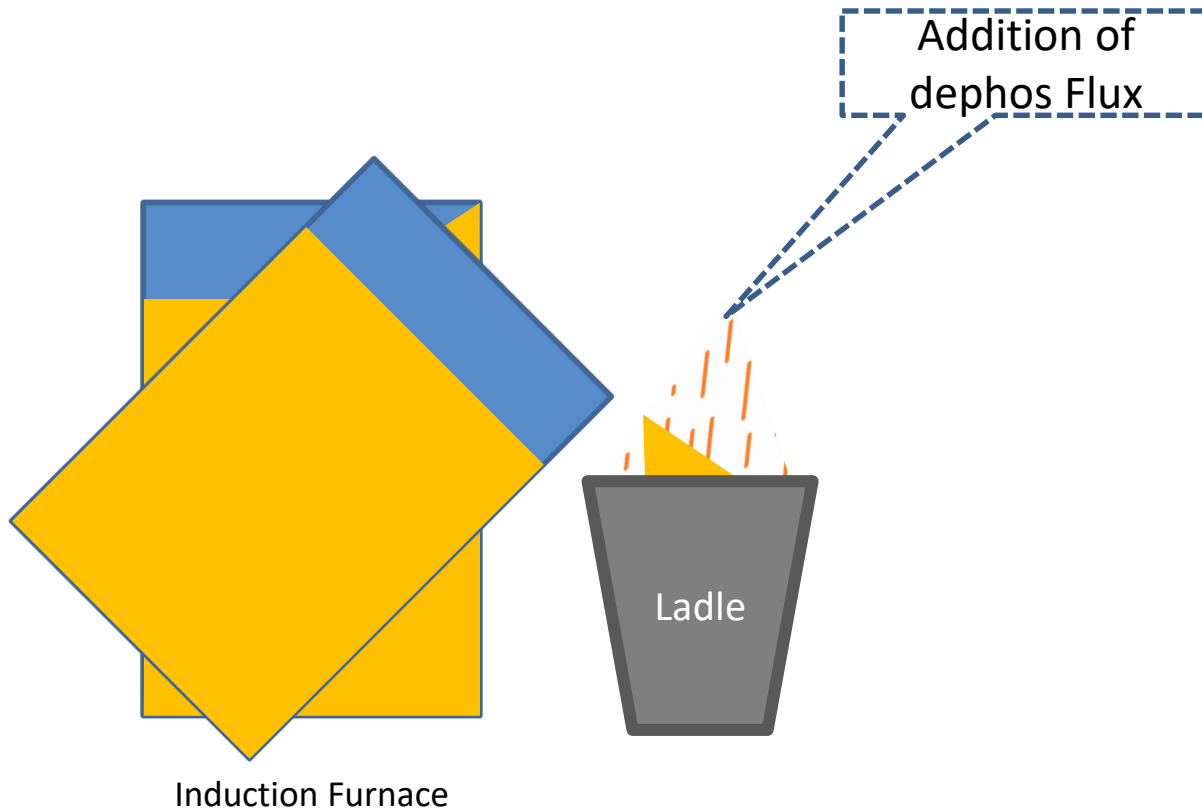



ELECTROTHERM

Slag removal and LRF station

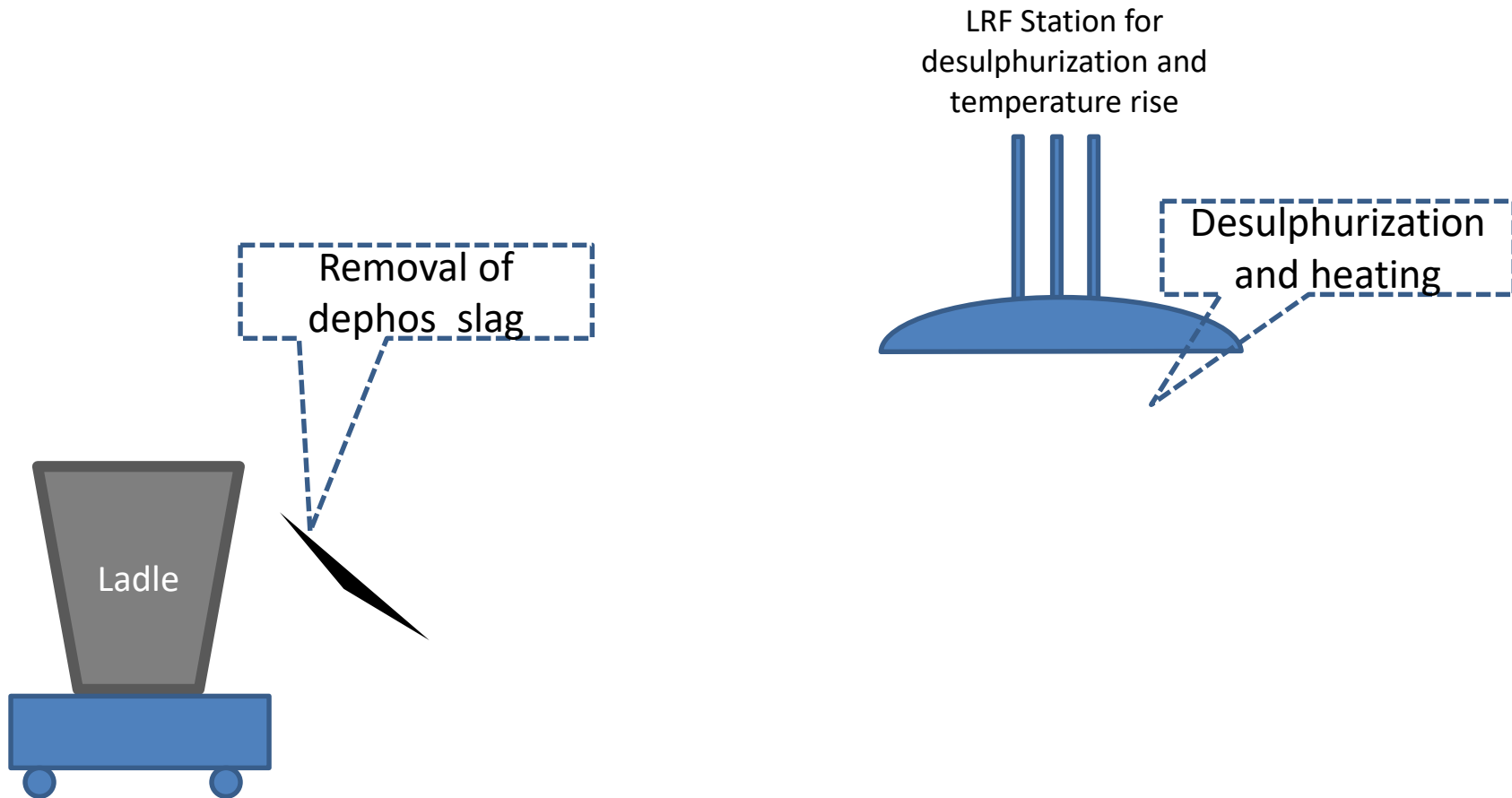



ELECTROTHERM

Main features

- **Act as a buffer in between melting and casting equipment**
- **Improving homogeneity of chemical composition and temperature**
- **Removes dissolved gases and inclusions**
- **Desulphurization (40 points)**
- **Dephosphorization (90 points)**



ELECTROTHERM

Various routes of steel making

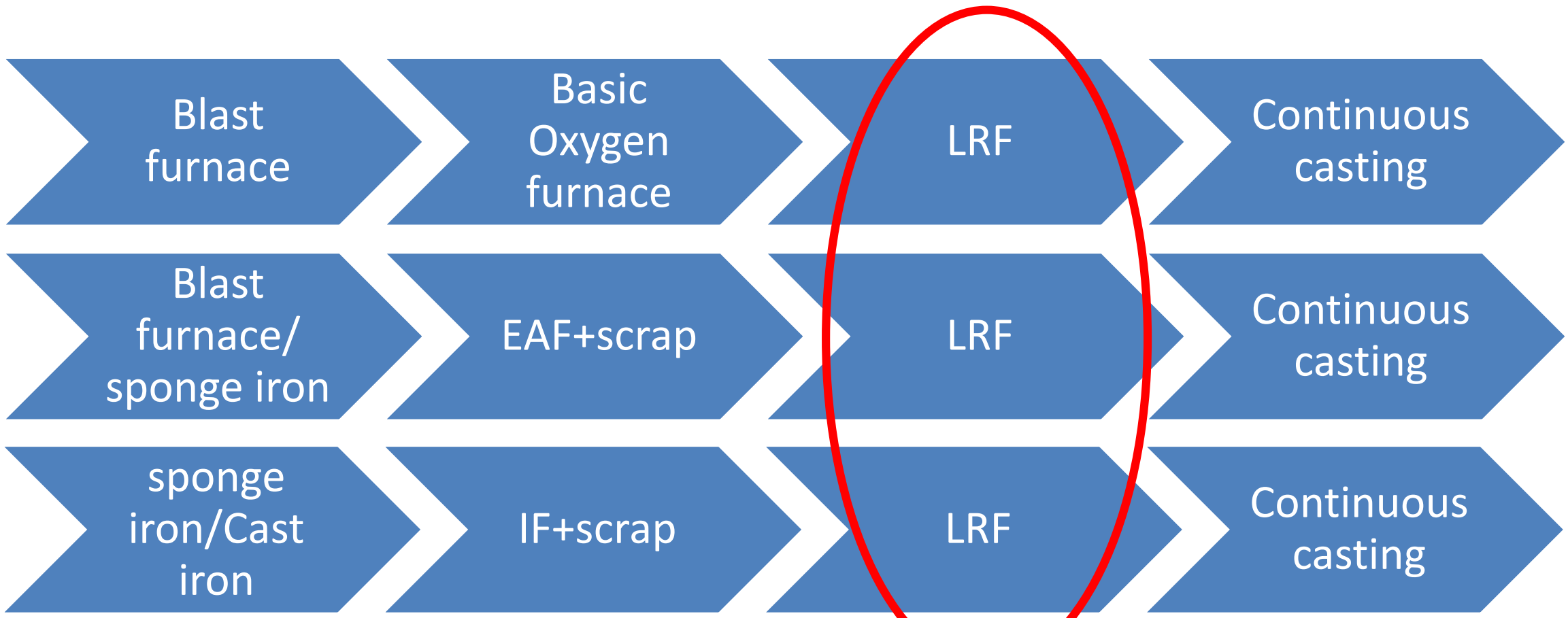



Concluding remarks

- Like integrated steel plants, induction furnace based steel plants are becoming popular now a days
- The plants use iron ore as a basic raw material
- Such integrated induction plants use very low amount of scrap
- BF-BOF and EAF based plants used LRF for final refining of steel
- In the same way, induction furnace based steel plants also use LRF for final refining of steel



ELECTROTHERM

Concluding remarks

- ELdFOS™ technology uses LRF to remove P and S from steel
- Use of integrated induction steel plants help produce construction grade TMT bars as per IS 1786
- The quality in terms of chemical and mechanical properties of TMT bars is same as that of BF-BOF route and EAF route
- Use of LRF makes the steel independent of initial steelmaking route to produce the steel as per IS 1786.