



The world's coolest, quietest and most energy efficient evaporative air conditioning

“Seeley International never stops striving to innovate and build the world’s most energy efficient heaters and air conditioners.

It is this commitment to excellence that’s at the heart of everything we do.”

Frank Seeley AM FAICD
Founder and Executive Chairman



THE AWARD WINNING COMPANY

Seeley International consistently wins awards each year for new product design, innovation and the environment.

Recent awards include:



sydney
design
awards



melbourne
design
awards



ABA/100

NEW PRODUCT
INNOVATION
WINNER 2017



UP TO 90% CHEAPER TO RUN THAN DUCTED REVERSE CYCLE AIR CONDITIONING*



LOWEST RUNNING COST IN AUSTRALIA

Cool your whole home from the cost of running a single light globe



AUSTRALIAN MADE

Built in Australia to withstand the harshest climates



QUIET TO RUN

Ask your dealer for a demonstration – see if you can hear how quiet it is



BUILT TO LAST

Enduring quality – 7 year comprehensive warranty[^]



LOW MAINTENANCE

Innovative design ensures minimal maintenance



FRESH, COOL CLEAN AIR

No stale recycled air



TOTAL CONTROL MADE EASY

Available with the touch screen MagIQtouch controller



LIFESTYLE

Perfect for alfresco living, with optional security vents for added protection



NATA TESTING

NATA accredited test results substantiate superior product performance.



COOL YOUR WHOLE HOME FROM THE COST OF RUNNING A SINGLE LIGHT GLOBE

Breezair is the world's first inverter evaporative air conditioner and that means lower energy usage and running costs.

With energy prices escalating, evaporative air conditioning has a significant and increasing edge on reverse cycle, when it comes to energy efficiency, performance and easy living.



LOWEST RUNNING COST IN AUSTRALIA

Up to 90% cheaper to run than ducted reverse cycle air conditioning



ENERGY EFFICIENT

Better for your pocket and for the environment

RUNNING COST PER YEAR*

Savings of up to \$346 per year!

When compared to 20kW reverse cycle

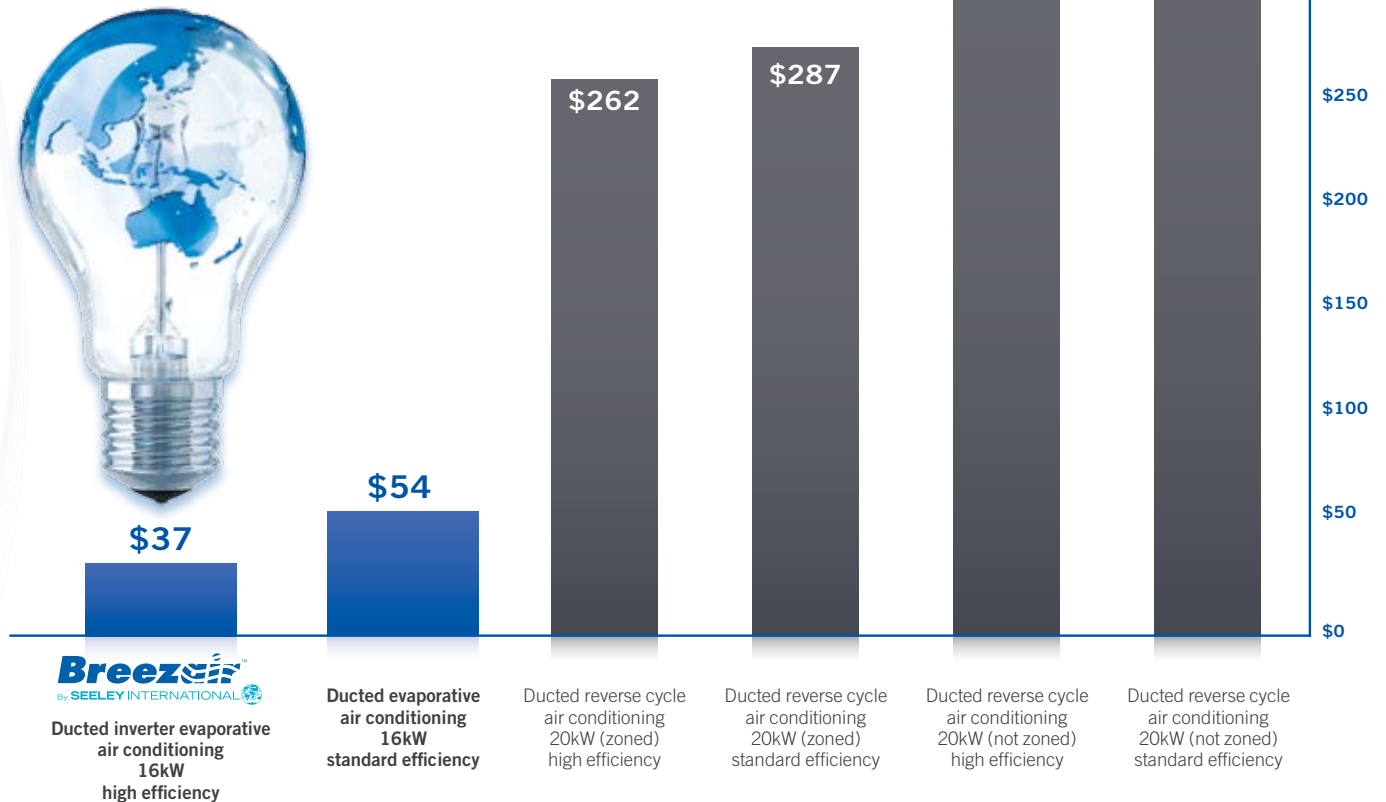

*Based on approximate running cost figures per annum sourced from Sustainability Victoria – see its Cooling Fact Sheet at: www.sustainability.vic.gov.au/services-and-advice/households/energy-efficiency/toolbox/energy-efficiency-fact-sheets. Assumes a whole house area of 166 square metres, with 300 hours usage, a 60% duty cycle for air conditioners, and an electricity tariff of 28 cents/kWh. No brand names are mentioned in the Sheet. Note that evaporative coolers also use water. Information correct at time of printing, 16/08/2017.

LOW WATER USAGE

WATER USAGE (L/YR)[^]

248,200	Shower (ordinary showerhead) 4 people - 10 min. per person per day
116,800	Shower (water-efficient showerhead) 5 people - 10 min. per person per day
58,400	Toilet (dual flush 8 L) 4 person home - 5 times per person per day
54,750	Washing machine (top loader) 150 L per cycle - 1 wash per day
48,600	Garden sprinkler 1 hour every 2nd day in Summer only
29,200	Bath (1/2 full) 1 x 80 L capacity per day
21,900	Washing machine (front loader) 60 L per cycle - 1 wash per day
6,570	Washing dishes 1 x 18 L capacity per day
6,570	Dishwasher 1 x 18 L capacity per day
5,405	Breezair evaporative air conditioning 14.8 L per day

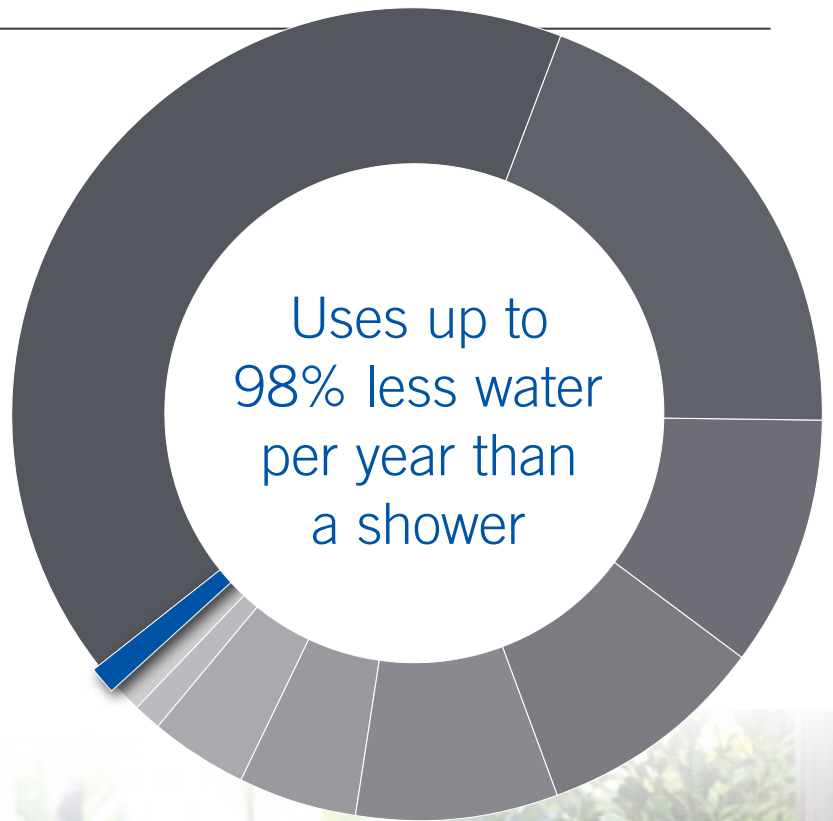

[^] Source: South East Water Corporation, Article: 'How much water do my appliances use', www.southeastwater.com.au, 2014. Breezair data is not in the Article, but is based on Melbourne 2005 weather data using 115m² house with medium to large Breezair evaporative unit running for 687 hours per year. Note: All figures are based on common-use assumptions.

BETTER FOR THE ENVIRONMENT

Every time a customer chooses a Breezair evaporative air conditioner over a refrigerated system, the benefits for the environment are significant.

The power consumption of just one ducted refrigerated air conditioner can result in up to 1.4 tonnes of harmful CO₂ being pumped into the atmosphere each year. On the other hand, Breezair evaporative air conditioners are so efficient, they produce less than one tenth of this volume.[^]

By choosing Breezair, you can help reduce the amount of harmful greenhouse emissions entering our environment.



REDUCED GREENHOUSE GAS EMISSIONS

Up to 90% less CO₂ emissions than ducted reverse cycle



EASY ON WATER USAGE

Innovative design for minimum water consumption

CO₂ EMISSIONS (KG/YR)[^]

CO₂ savings equivalent to planting 18 gum trees*

When compared to 20kW reverse cycle

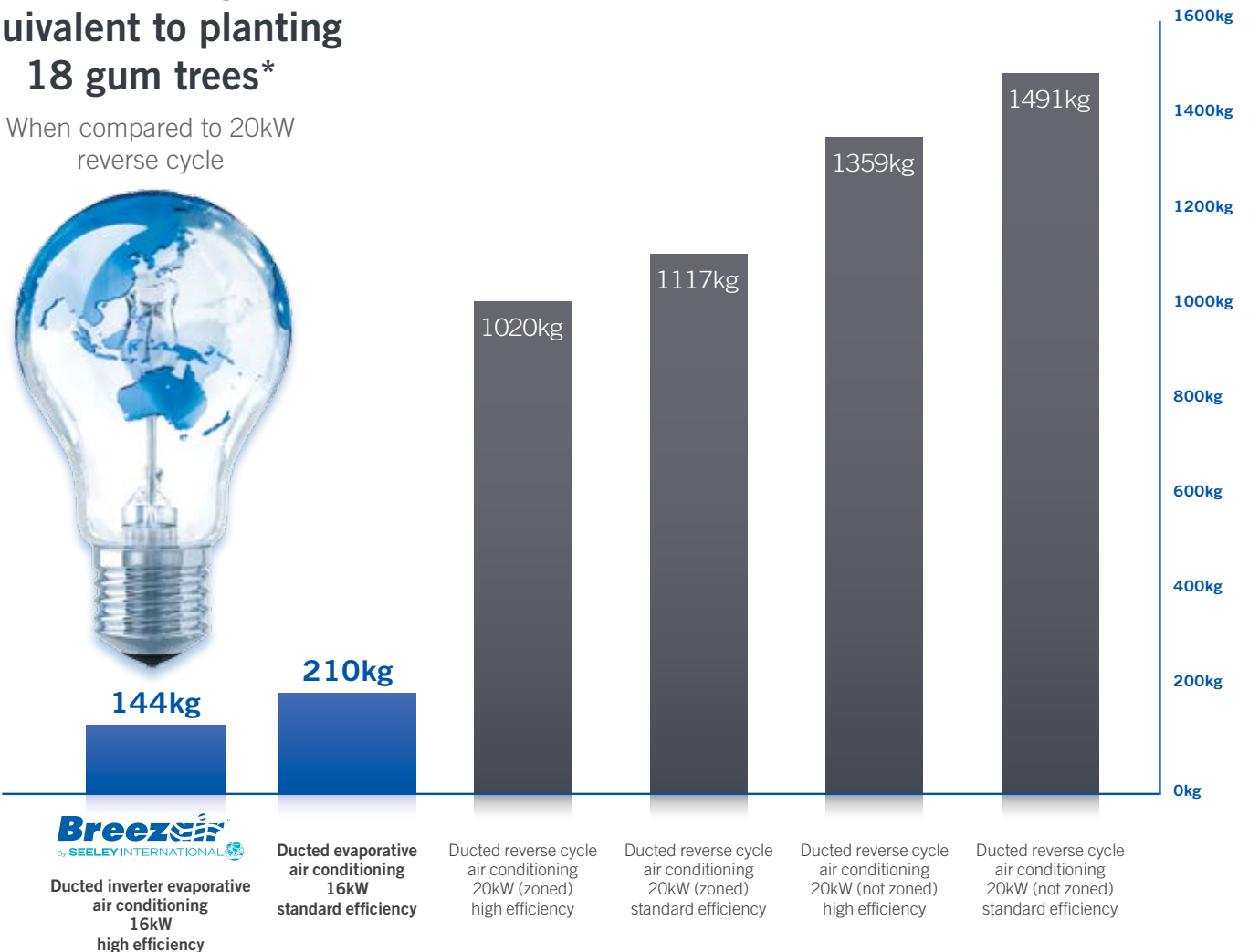

[^] Seeley International's calculations, based on publicly available data (2008). CO₂ emissions based on 1.09 kg CO₂ e/kWhr electricity purchased from grid for Victoria. Data sourced from Part 6 of Schedule 1 to the National Greenhouse and Energy Reporting (Measurement) Determination 2008 (Compilation No. 7, dated 1 July 2016).

*This is an estimate based on the CO₂ calculation above and using data from forestlearning.edu.au, 'Carbon and its storage in forest and wood products' article, published 2011. Calculation based on a 12 year old spotted gum tree weighing 600kg.

MAGIQTOUCH CONTROLLER

Smart, sophisticated and incredibly intuitive, your MagIQtouch controller makes operating your Breezair, a breeze. Control the temperature, fan speed and many more features on a user friendly touch screen. Discreet and modern design will blend seamlessly into the décor of your home.



TECHNOLOGY THAT PUTS YOU IN CONTROL

High IQ touch screen, wall mounted controller

MAIN FEATURES



PROGRAM MODE

Programmable 7 day, 4 time period program, customisable to suit your lifestyle (including a temporary over-ride function).



ENERGY SAVING QUIET MODE

When turned on, the energy saving quiet mode automatically reduces fan speed overnight for even greater economy and whisper-quietness.



AUTO-CLEAN™ FUNCTION

World's first fully automated pad cleansing capability enables you to set and forget ensuring your cooling pads remain clean, fresh and functional all summer long, season after season.*

*Only for cooler models fitted with the water management system. Ask your dealer for further information.



CHILD ACCESS LOCK

Select a pin code to restrict access to your controller.



MagIQtouch controller shown at actual size

For more information on additional features please visit breezair.com.au

OPTIONAL EXTRA

MAGIQTOUCH AIR SENSOR

Allows you to mount your MagIQtouch controller in the most convenient place in your home, as the MagIQtouch Air Sensor will then take over temperature control from the MagIQtouch controller. This can then be located in the best place in the house to ensure ultimate cooling comfort for everyone.

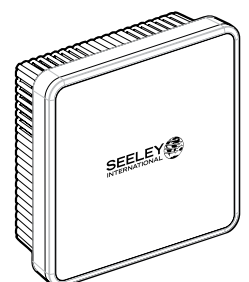

**EXCLUSIVE TO
CLIMATE MASTERS OF
SEELEY INTERNATIONAL
SPECIALISTS
EXTERNAL AIR SENSOR***



Displays current outside temperature

Intuitively optimises water and energy usage based on outside ambient conditions

Extends the life of your air conditioner by automatically draining the water tank when temperature nears freezing.

*Only available on Breezair EXS models



SCAN THIS QR CODE TO SEE THE MAGIQTOUCH CONTROLLER IN ACTION ON YOUR SMARTPHONE

- Simply download **QR Code Reader/Scanner** from the App Store or Google Play
- Scan the code and experience the MagIQtouch

BREEZAIR DUCTED EVAPORATIVE AIR

FEATURES AND BENEFITS

HIGHLY DURABLE AND NON-CORROSIVE OUTER CASING

- High performance Permatuf® polymer construction will not corrode or rust

ICON® SERIES FAN IS ULTRA-QUIET

- Designed to deliver optimum air output at all times
- Ultra-quiet centrifugal fan with 10 speeds
- Use “Fan Only” mode (no water) to blow fresh air through the home and expel odours

HUSHPOWER® DIRECT DRIVE INVERTACOOOL MOTOR USES LESS ENERGY

- Exclusive to Breezair and manufactured in Australia
- Incredibly quiet and efficient throughout operating range
- Unsurpassed reliability
- Corrosion proofed throughout with parts that won't rust

POWER CONTROL MODULE HELPS SAVE W

- Advanced electronics ensure maximum efficiency
- Microprocessor constantly analyses water quality
- Incredibly smart, exceptionally reliable and durable

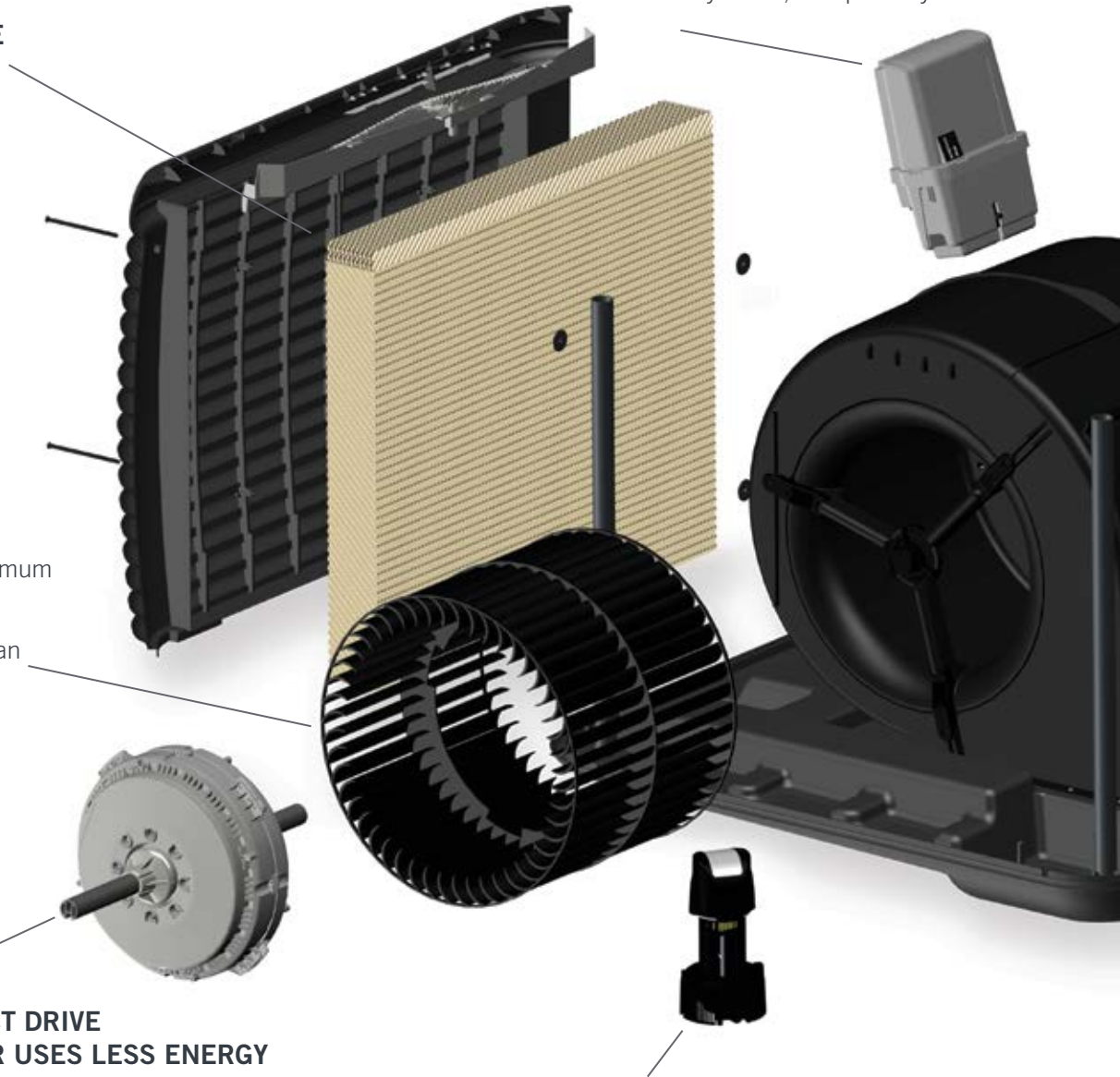

TORNADO® PUMP THAT WON'T BLOCK

- Australian designed and manufactured
- Exceptional reliability in extreme conditions
- Dual directional – it can't block!

OPTIONAL EXTRA FIREWALL EMBER SCREEN

Helps guard against ember attack in bushfires
Made from non-combustible mesh
Maximum aperture of 2mm
Can be fitted to existing cooler pad frames
Minimal reduction in air flow of 5%

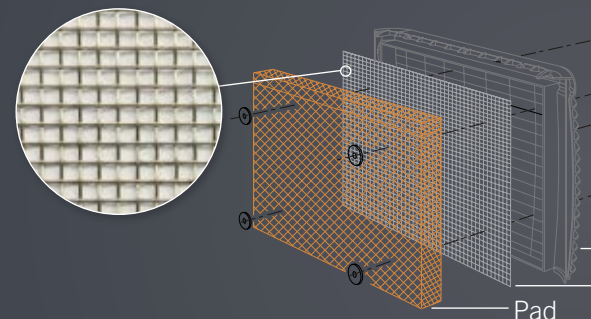

R CONDITIONING

WATER AND POWER

y
y, water consumption and power output
ble

DRAIN AND CLEAN FUNCTION

- Automatic water draining when the system is not in use avoids ongoing algae growth

Only available with selected MagIQtouch controller models. Regular maintenance (typically every 2 years for domestic use) is still required.

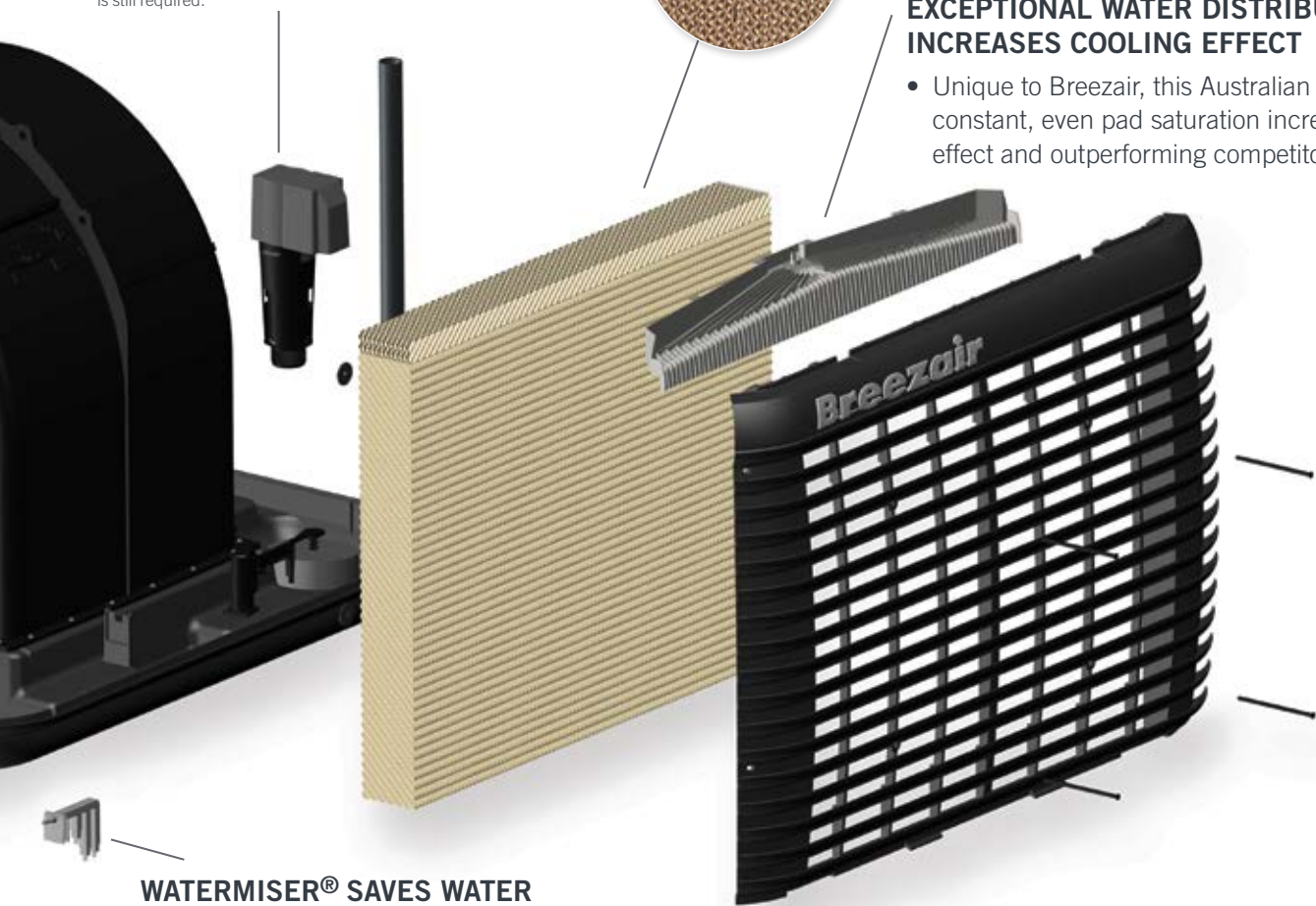

WATERMISER® SAVES WATER

- Uses the minimum amount of water to achieve high efficiency cooling
- Water quality monitoring to maximise water savings
- Leak detection monitor

Optional on the EXQ series, only available with the Harmony MagIQtouch controller

BREAKTHROUGH MINI-CELL[^] CHILLCEL[®] PAD TECHNOLOGY!

DRAMATIC IMPROVEMENT IN COOLING EFFICIENCY

- Revolutionary new Mini-cell structure provides a new development in cooling technology
- New enhanced small cell design, means that the Breezair range boasts a new cutting edge level of cooling capacity – up to 21% more than before, for the highest efficiency product
- New pad formulation has resulted in having 25% more surface area dramatically improving cooling efficiency
- The only evaporative cooling pads fully manufactured in Australia to suit the harsh Australian climate, and **now**, the absolute **over-performer!**

[^]Patent pending

EXCEPTIONAL WATER DISTRIBUTION INCREASES COOLING EFFECT

- Unique to Breezair, this Australian design ensures constant, even pad saturation increasing the cooling effect and outperforming competitor products

WEATHERSEAL[®] REDUCES DRAUGHTS AND DUST

- Automatic sealing system
- Reduces need for winter cover

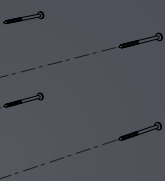

Pad frame

Firewall ember screen

BREEZAIR DUCTED EVAPORATIVE AIR



SUPERCOOL

Enjoy superior cooling with Breezair Supercool.

This premium range has extra thick Chillcel pads, producing up to 13% more cooling when compared to the Icon range. Breezair Supercool is only available from your Climate Masters of Seeley International specialist.



	EXS140	EXS160	EXS180	EXS200	EXS220
Cooling capacity (kW)	8.1	11.4	13.1	14.3	15.1
Nominal power motor (W)	500	550	750	1100	1500
Width (mm)	1160	1160	1160	1160	1160
Depth (mm)	1160	1160	1160	1160	1160
Height (mm)	660	860	860	860	860
Operating weight (kg)	81	94	94	94	94
Airflow (L/sec)	1310	1720	2060	2320	2540



ICON

The Breezair Icon range is a proven high performer, cooling your whole home and saving you on energy costs.

	EXQ130	EXQ150	EXQ170	EXQ190	EXQ210
Cooling capacity (kW)	7.6	10.8	11.6	13.8	14.5
Nominal power motor (W)	500	550	750	1100	1500
Width (mm)	1160	1160	1160	1160	1160
Depth (mm)	1160	1160	1160	1160	1160
Height (mm)	660	860	860	860	860
Operating weight (kg)	77	90	90	90	91
Airflow (L/sec)	1300	1720	2070	2320	2540

The above data was drawn from Meridian Test Laboratory's test analysis. The testing was performed by a NATA accredited laboratory to the requirements of the Australian standard AS2913-2000 "Evaporative Air Conditioning Equipment." Achievable with ambient 38 °C DB, 21 °C WB, room temperature 27.4 °C.

R CONDITIONING RANGE

AVAILABLE COLOURS



Slate Grey*



Beige*



Terracotta*



Heritage Green*

*Colours may vary. Heritage Green made to order.

KEEP YOUR HOME SECURE

Did you know you can cool your home without leaving your doors and windows open?

Ask your dealer about installing a cost effective and easy to install **Security Relief Vent** in your home, allowing you to run your evaporative air conditioner while you are out, with all your windows and doors safely closed and locked.

Your home will stay cooler as cooled air is released into the roof space. When you return home, simply open up your windows and doors as normal, maintaining the fresh cool air throughout your home and open living areas.



LOOKING FOR A COMBINED COOLING AND HEATING SOLUTION?

Seeley International's range of products also includes ducted gas heating that complements your evaporative air conditioning system. Take advantage of controlling your cooling and heating systems from the same controller – the innovative touch screen MagIQtouch controller.

Ask your dealer for the right solution for your home.

PEACE OF MIND WITH OUR SPECIALIST DEALER NETWORK



Members of Climate Masters of Seeley International are heating and cooling experts, and provide a level of service you won't get anywhere else[^].

[^]Members are independent retailers.



Unsurpassed professionalism and expertise



Unrivalled quality and service



After care that really delivers



Reliability at every level



Exclusive Supercool range



COMPREHENSIVE WARRANTY

For complete peace of mind, Breezair backs every one of its air conditioning systems with an industry leading comprehensive warranty program.

This includes a 7 year warranty* (with a compulsory chargeable service in the fourth year), 10 year cover on all structural components, plus a hefty 25 year cover against corrosion, on its Permatuf® cabinets.



Please refer to your home owner's manual at breezair.com.au for all service and warranty terms and conditions.

REGISTER YOUR WARRANTY AND GO INTO THE DRAW TO WIN \$500 WORTH OF PRIZES[^]

Prize includes 2 free services (up to the value of \$400) and a \$100 eftpos gift card

All you need is your home owners' manual then:

- Go to seeleyinternational.com and click on Get Support at the top of the page
- Choose the Breezair brand
- Or
- Scan the QR code on the back page of the home owner's manual with a smart phone or tablet

[^]Terms and conditions apply. See breezair.com.au for more information, including the dates of the promotion.



BREEZAIR NATIONAL SERVICE NETWORK

Seeley International has established a network of highly professional dealers and service agents throughout Australia who are only a phone call away. Should you need to contact a service agent, please call 1300 650 644.

*The 7 year comprehensive warranty is available exclusively (i.e. only) from Seeley International participating dealers. The warranty has terms and conditions, including the requirement for servicing of the product in accordance with the owner's manual. In the fourth year the service must be performed by Seeley International or its appointed nominee.



BREEZAIR

Ducted Evaporative Air Conditioning

BRAEMAR

Ducted Evaporative Air Conditioning | Ducted Gas Heating
Reverse Cycle Air Conditioning | Gas Wall Furnaces and Space Heaters

CLIMATE WIZARD

Indirect Evaporative Air Conditioning

CONVAIR

Portable Air Conditioning

COOLAIR

Ducted Evaporative Air Conditioning

COOLERADO

Indirect Evaporative Air Conditioning

AIRA

Direct and Indirect Evaporative Air Conditioning | Ducted Gas Heating
Commercial Gas Space Heating | Energy Recovery Systems

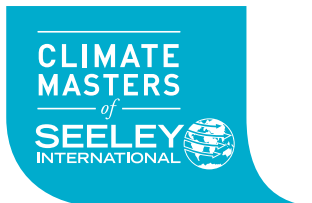

To locate your nearest Climate Masters of Seeley International dealer call **1300 136 515** or go to **climatemastersofsi.com.au**

Please visit **breezair.com.au** to find out about our current promotions.*

*Promotions are seasonal and do not run at all times of the year.



With the generous support of our Australasian dealers we are proud to be the National Variety Bash partner supporting kids in need across Australia.

Seeley International Pty Ltd
ABN 23 054 687 035

112 O'Sullivan Beach Road, Lonsdale, SA 5160
Phone: (08) 8328 3850 Fax: (08) 8328 3950

Email: marketing@seeleyinternational.com
www.seeleyinternational.com

Information in this brochure was correct at the time of preparation. E & OE



Quality
ISO 9001

1,013kg
CO₂ saved
on this project

This brochure was printed by an environmentally friendly printer certified in accordance with ISO14001 Environmental Management Systems. As a certified carbon neutral printer, 1,013kg of CO₂ was saved during the production process.

Cat No CMSI001 REV F (0717)