

Guide to Low-Emission Boiler and Combustion Equipment Selection

C. B. Oland



DOCUMENT AVAILABILITY

Reports produced after January 1, 1996, are generally available free via the U.S. Department of Energy (DOE) Information Bridge.

Web site <http://www.osti.gov/bridge>

Reports produced before January 1, 1996, may be purchased by members of the public from the following source.

National Technical Information Service
5285 Port Royal Road
Springfield, VA 22161
Telephone 703-605-6000 (1-800-553-6847)
TDD 703-487-4639
Fax 703-605-6900
E-mail info@ntis.fedworld.gov
Web site <http://www.ntis.gov/support/ordernowabout.htm>

Reports are available to DOE employees, DOE contractors, Energy Technology Data Exchange (ETDE) representatives, and International Nuclear Information System (INIS) representatives from the following source.

Office of Scientific and Technical Information
P.O. Box 62
Oak Ridge, TN 37831
Telephone 865-576-8401
Fax 865-576-5728
E-mail reports@adonis.osti.gov
Web site <http://www.osti.gov/contact.html>

This report was prepared as an account of work sponsored by an agency of the United States Government. Neither the United States Government nor any agency thereof, nor any of their employees, makes any warranty, express or implied, or assumes any legal liability or responsibility for the accuracy, completeness, or usefulness of any information, apparatus, product, or process disclosed, or represents that its use would not infringe privately owned rights. Reference herein to any specific commercial product, process, or service by trade name, trademark, manufacturer, or otherwise, does not necessarily constitute or imply its endorsement, recommendation, or favoring by the United States Government or any agency thereof. The views and opinions of authors expressed herein do not necessarily state or reflect those of the United States Government or any agency thereof.

**GUIDE TO LOW-EMISSION BOILER AND COMBUSTION
EQUIPMENT SELECTION**

C. B. Oland

Date Published: April 2002

Prepared for the
U.S. Department of Energy
Office of Industrial Technologies

Prepared by
OAK RIDGE NATIONAL LABORATORY
Oak Ridge, Tennessee 37831
managed by
UT-BATTELLE, LLC
for the
U.S. DEPARTMENT OF ENERGY
under contract DE-AC05-00OR22725

CONTENTS

	Page
LIST OF FIGURES	vii
LIST OF TABLES	ix
ACRONYMS	xi
ACKNOWLEDGMENTS	xiii
EXECUTIVE SUMMARY	xv
1. INTRODUCTION	1-1
1.1 SCOPE AND OBJECTIVES	1-1
1.2 APPROACH	1-2
1.3 REFERENCE	1-3
2. INDUSTRIAL, COMMERCIAL, AND INSTITUTIONAL BOILERS	2-1
2.1 TYPES OF ICI BOILERS	2-1
2.1.1 Firetube Boilers	2-2
2.1.2 Watertube Boilers	2-5
2.1.3 Other Combustion Boilers	2-16
2.2 FUEL FEED SYSTEMS	2-18
2.2.1 Stokers	2-19
2.2.1.1 Underfeed stokers	2-19
2.2.1.2 Overfeed stokers	2-20
2.2.2 Burners	2-23
2.3 EMISSION RATES	2-24
2.3.1 Uncontrolled Emissions	2-25
2.3.2 Controlled Emissions	2-26
2.4 REFERENCES	2-26
3. FUELS, EMISSIONS, AND EFFICIENCY	3-1
3.1 FUELS	3-1
3.1.1 Coal	3-1
3.1.1.1 Lignite	3-5
3.1.1.2 Subbituminous	3-5
3.1.1.3 Bituminous	3-5
3.1.1.4 Anthracite	3-7
3.1.2 Fuel Oil	3-7
3.1.3 Natural Gas	3-8
3.1.4 Biomass	3-10
3.1.5 Refuse-Derived Fuel	3-10
3.1.6 Other Fuels	3-10
3.1.7 Mixed Fuels	3-11
3.2 EMISSIONS	3-11
3.2.1 Nitrogen Oxides	3-12
3.2.1.1 Thermal NO _x	3-12
3.2.1.2 Fuel NO _x	3-13
3.2.1.3 Prompt NO _x	3-14
3.2.2 Sulfur Dioxide	3-14
3.2.3 Particulate Matter	3-15
3.2.4 Carbon Monoxide	3-15
3.2.5 Hazardous Air Pollutants	3-16

3.3	EFFICIENCY	3-16
3.3.1	Combustion Losses	3-17
3.3.2	Boiler Losses	3-17
3.4	REFERENCES	3-19
4.	EMISSIONS STANDARDS AND COMPLIANCE ISSUES	4-1
4.1	CLEAN AIR ACT	4-1
4.1.1	National Ambient Air Quality Standards	4-3
4.1.1.1	Ozone	4-3
4.1.1.2	Nitrogen oxides	4-5
4.1.1.3	Sulfur dioxide	4-6
4.1.1.4	Carbon monoxide	4-6
4.1.1.5	Particulate matter	4-7
4.1.2	Emissions from Existing Steam Generating Units	4-8
4.1.2.1	Sulfur dioxide reduction program	4-8
4.1.2.2	Nitrogen oxides reduction program	4-9
4.1.3	New Source Performance Standards	4-10
4.1.3.1	Performance standards for new steam generating units	4-10
4.1.3.2	Performance standards for new municipal waste combustion units	4-11
4.1.4	Permitting Requirements	4-12
4.1.4.1	Acid Rain Program Permits	4-14
4.1.4.2	State Operating Permit Programs	4-15
4.2	INFORMATION SOURCES	4-18
4.3	PERMITTING BASICS	4-19
4.4	LESSONS LEARNED	4-23
4.5	REFERENCES	4-24
5.	EMISSION CONTROL TECHNIQUES	5-1
5.1	PRECOMBUSTION	5-1
5.2	COMBUSTION	5-2
5.2.1	Nitrogen Oxides Control Techniques	5-4
5.2.1.1	Peak flame temperature reduction	5-5
5.2.1.2	Operational modifications	5-5
5.2.1.3	Staged combustion	5-7
5.2.1.4	Natural gas reburning	5-7
5.2.1.5	Low-NO _x burners	5-8
5.2.1.6	Ultra low-NO _x burners	5-8
5.2.2	Sulfur Dioxide Control Techniques	5-10
5.2.3	Particulate Matter Control Techniques	5-10
5.3	POSTCOMBUSTION	5-10
5.3.1	Nitrogen Oxides Flue-Gas Treatment Techniques	5-10
5.3.1.1	Selective catalytic reduction	5-12
5.3.1.2	Selective noncatalytic reduction	5-13
5.3.1.3	Emerging nitrogen oxides flue-gas treatment technologies	5-13
5.3.2	Sulfur Dioxide Flue-Gas Treatment Techniques	5-14
5.3.2.1	Nonregenerable processes	5-14
5.3.2.2	Regenerable processes	5-16
5.3.3	Particulate Matter Flue-Gas Treatment Techniques	5-16
5.3.3.1	Mechanical collectors	5-16
5.3.3.2	Wet scrubbers	5-17

5.3.3.3	Electrostatic precipitators (ESPs)	5-17
5.3.3.4	Fabric filters	5-18
5.4	REFERENCES	5-20
6.	SELECTION CONSIDERATIONS	6-1
6.1	BOILERS AND COMBUSTION EQUIPMENT	6-1
6.1.1	Coal-Fired Boilers	6-2
6.1.2	Fuel-Oil-Fired and Gas-Fired Boilers	6-4
6.1.3	Nonfossil-Fuel-Fired Boilers	6-11
6.2	EMISSION CONTROL EQUIPMENT	6-19
6.2.1	Nitrogen Oxides Reduction	6-20
6.2.2	Sulfur Dioxide Reduction	6-23
6.2.3	Particulate Matter Reduction	6-24
6.3	SYSTEM CONFIGURATION	6-25
6.4	REFERENCES	6-27
	SELECTED BIBLIOGRAPHY	S-1
	GLOSSARY	G-1
Appendix A.	NEW SOURCE PERFORMANCE STANDARDS UNDER TITLE IV OF THE CLEAN AIR ACT	A-1

LIST OF FIGURES

Figure		Page
ES.1	Format used to present emission control options for various fuel and boiler combinations	xvii
2.1	Configuration of HRT firetube boiler	2-3
2.2	Configuration of Scotch package firetube boiler	2-3
2.3	Configuration of firebox firetube boiler.....	2-4
2.4	Configuration of package watertube boiler.....	2-5
2.5	Configuration of field-erected watertube boiler.....	2-6
2.6	Configuration of watertube boiler for burning RDF	2-8
2.7	Configuration of watertube boiler for burning MSW	2-9
2.8	Configuration of watertube boiler for burning solid fuel such as wood, biomass, or stoker coal.....	2-10
2.9	Configuration of watertube boiler for burning PC.....	2-11
2.10	Configuration of bubbling FBC watertube boiler	2-12
2.11	Configuration of circulating FBC watertube boiler	2-13
2.12	Configuration of pressurized FBC boiler system.....	2-14
2.13	Configuration of tubes for “A” package watertube boiler	2-15
2.14	Configuration of tubes for “D” package watertube boiler	2-15
2.15	Configuration of tubes for “O” package watertube boiler	2-16
2.16	Configuration of cast iron boiler.....	2-17
2.17	Configuration of vertical tubeless boiler.....	2-18
2.18	Cross section of underfeed, side-ash discharge stoker.....	2-20
2.19	Cross section of overfeed, water-cooled, vibrating-grate, mass-feed stoker	2-21
2.20	Cross section of overfeed, traveling-grate, mass-feed stoker.....	2-21
2.21	Cross section of overfeed, traveling-grate, spreader stoker	2-22
2.22	Cross section of overfeed air-cooled, vibrating-grate, spreader stoker.....	2-22
2.23	Cross section of overfeed, water-cooled, vibrating-grate, spreader stoker	2-23
5.1	Configuration of SCR reaction chamber.....	5-12
5.2	Configuration of wet scrubber	5-15
5.3	Configuration of dry scrubber.....	5-16
5.4	Configuration of ESP	5-18
5.5	Configuration of fabric filter or baghouse	5-19
6.1	Emission control options for coal-fired, stoker-fed, watertube boilers.....	6-5
6.2	Emission control options for PC-fired watertube boilers.....	6-6
6.3	Emission control options for coal-fired FBC watertube boilers	6-7
6.4	Emission control options for coal-fired, stoker-fed, firetube boilers	6-8
6.5	Emission control options for fuel-oil-fired watertube and firetube boilers.....	6-10
6.6	Emission control options for natural-gas-fired watertube and firetube boilers.....	6-12
6.7	Emission control options for biomass-fired, stoker-fed, watertube boilers	6-13
6.8	Emission control options for biomass-fired FBC watertube boilers	6-14
6.9	Emission control options for biomass-fired, stoker-fed, firetube boilers.....	6-15
6.10	Emission control options for RDF-fired, stoker-fed, watertube boilers.....	6-16
6.11	Emission control options for RDF-fired FBC watertube boilers	6-17
6.12	Emission control options for RDF-fired, stoker-fed, firetube boilers	6-18
6.13	Examples of flue-gas treating system configurations for solid-fuel-fired boilers.....	6-26

LIST OF TABLES

Table		Page
ES.1	Emission control techniques discussed in the guide	xvi
2.1	Fuels typically fired in ICI firetube boilers.....	2-4
2.2	Fuels typically fired in ICI watertube boilers	2-7
2.3	Terminology used to identify burners.....	2-24
3.1	Fuels fired in boilers to generate hot water or steam	3-2
3.2	Key properties for selected fuels.....	3-3
3.3	Lignite coals.....	3-5
3.4	Subbituminous coals	3-5
3.5	Bituminous coals.....	3-6
3.6	Anthracitic coals	3-7
3.7	Fuel oil grades established by ASTM	3-9
3.8	Nitrogen oxides.....	3-12
4.1	Summary of NAAQS under Title I of the CAA	4-4
4.2	Emissions by source of NO _x and SO ₂ in the United States	4-5
4.3	Selected NO _x reduction regulations under Titles I and IV of the CAA.....	4-7
4.4	BACT and LAER applicability and requirements	4-13
4.5	Compliance options for SO ₂ emissions	4-16
4.6	Compliance options for NO _x emissions.....	4-17
4.7	General guidance for obtaining a permit for a new air pollution source.....	4-20
5.1	Techniques for controlling emissions before combustion	5-2
5.2	Techniques for controlling emissions during combustion	5-3
5.3	Guidance for installation and operation of boilers.....	5-6
5.4	Techniques for controlling emissions after combustion	5-11
6.1	Common boiler and fuel feed system combinations	6-1
6.2	Typical capacity ranges for combustion boilers.....	6-3
6.3	Performance summary for NO _x control techniques on ICI firetube boilers	6-21
6.4	Performance summary for NO _x control techniques on ICI watertube boilers	6-22
6.5	Performance summary for NO _x flue-gas treatment techniques on ICI boilers	6-23
A.1	Summary of new source performance standards (NSPS) for electric utility steam-generating units	A-3
A.2	Summary of NSPS for industrial-commercial-institutional (ICI) steam-generating units	A-5
A.3	Summary of NSPS for small industrial ICI-generating units.....	A-11
A.4	Summary of NSPS for large municipal waste combustion units	A-14

ACRONYMS

ABMA	American Boiler Manufacturers Association
AEL	Alternative Emission Limit
ASME	American Society of Mechanical Engineers
ASTM	American Society for Testing and Materials
ATW	Air Toxics Web site
BACM	Best Available Control Measures
BACT	Best Available Control Technology
BF	bias firing
BOOS	burners out of service
BT	burner tuning
CAA	Clean Air Act
CAAA	Clean Air Act Amendments of 1990
CATC	Clean Air Technology Center
CEM	continuous emission monitoring
CFR	<i>Code of Federal Regulations</i>
CHIEF	Clearinghouse for Inventories and Emission Factors
CIBO	Council of Industrial Boiler Owners
CO	carbon monoxide
CO ₂	carbon dioxide
DOE	U.S. Department of Energy
EMC	Emission Measurement Center
ESP	electrostatic precipitator
EPA	U.S. Environmental Protection Agency
EPRI	Electric Power Research Institute
FBC	fluidized-bed combustion
FGD	flue-gas desulfurization
FGR	flue gas recirculation
FIR	fuel-induced recirculation and forced-internal recirculation
FR	<i>Federal Register</i>
HAP	hazardous air pollutant
HCN	hydrogen cyanide
HRT	horizontal return tubular
ICI	industrial/commercial/institutional
IFGR	induced flue-gas recirculation
LAER	Lowest Achievable Emission Rate
LEA	low excess air
LNB	low-NO _x burner
LP	liquefied petroleum
MACT	Maximum Achievable Control Technology
MCR	maximum continuous rating
MOU	Memorandum of Understanding
MSW	municipal solid waste
NAA	nonattainment area
NAAQS	National Ambient Air Quality Standards
NESCAUM	Northeast States for Coordinated Air Use Management
NESHAPs	National Emissions Standards for Hazardous Air Pollutants
NFPA	National Fire Protection Association

NGR	natural gas reburning
NO _x	nitrogen oxides
NSPS	New Source Performance Standards or Standards of Performance for New Stationary Sources
NSR	New Source Review
OAR	Office of Air and Radiation
OFA	overfire air
OIT	Office of Industrial Technologies
ORNL	Oak Ridge National Laboratory
OT	oxygen trim
OTAG	Ozone Transport Assessment Group
OTR	Ozone Transport Region
OTC	Ozone Transport Commission
PC	pulverized coal
PM	particulate matter
PSD	prevention of significant deterioration
RACM	Reasonably Available Control Measure
RACT	Reasonably Available Control Technology
RAP	reducing air preheat
RBLC	RACT/BACT/LAER Clearinghouse
RDF	refuse-derived fuel
SCA	staged combustion air
SCRAM	Support Center for Regulatory Air Models
SCR	selective catalytic reduction
SI	steam injection
SIP	State Implementation Plan
SNCR	selective noncatalytic reduction
SO ₂	sulfur dioxide
T-BACT	Best Available Control Technology for Toxics
TDF	tire-derived fuel
TTN	Technology Transfer Network
UHC	unburned hydrocarbon
UL	Underwriters Laboratories
ULNB	ultra low-NO _x burner
VOC	volatile organic compound
WI	water injection

ACKNOWLEDGMENTS

The author gratefully acknowledges the U.S. Department of Energy, Office of Industrial Technology, Steam System BestPractices Program for sponsoring the development of this guide. Special thanks are extended to Fred Hart and Bob Gemmer of DOE for their support and guidance. Efforts by Bob Bessette of the Council of Industrial Boiler Owners, Randy Rawson of the American Boiler Manufacturers Association, and Russell Mosher of R. N. Mosher and Associates, LLC, to arrange meetings, identify technical reviewers, and forward reviewer comments helped to ensure that the broad interests of the boiler industry are reflected in the guide. Regulatory guidance provided by Jim Eddinger and Fred Porter of the U.S. Environmental Protection Agency and consultation with Greg Harrell of the University of Tennessee and Carroll Hooper of Steam Solutions, Inc., about the scope and content of the guide are also very much appreciated. The author also gratefully acknowledges Tony Wright and Mitch Olszewski of the Oak Ridge National Laboratory for managing this project, establishing contacts within the boiler industry, and providing helpful comments and suggestions.

EXECUTIVE SUMMARY

Boiler owners and operators who need additional generating capacity face a number of legal, political, environmental, economic, and technical challenges. Their key to success requires selection of an adequately sized low-emission boiler and combustion equipment that can be operated in compliance with emission standards established by state and federal regulatory agencies.

Recognizing that many issues are involved in making informed selection decisions, the U.S. Department of Energy (DOE), Office of Industrial Technologies (OIT) sponsored efforts at the Oak Ridge National Laboratory (ORNL) to develop a guide for use in choosing low-emission boilers and combustion equipment. To ensure that the guide covers a broad range of technical and regulatory issues of particular interest to the commercial boiler industry, the guide was developed in cooperation with the American Boiler Manufacturers Association (ABMA), the Council of Industrial Boiler Owners (CIBO), and the U.S. Environmental Protection Agency (EPA).

The guide presents topics pertaining to industrial, commercial, and institutional (ICI) boilers. Background information about various types of commercially available boilers is provided along with discussions about the fuels that they burn and the emissions that they produce. Also included are discussions about emissions standards and compliance issues, technical details related to emissions control techniques, and other important selection considerations. Although information in the guide is primarily applicable to new ICI boilers, it may also apply to existing boiler installations.

Use of the guide is primarily intended for those involved in either expanding current steam or hot water generating capacity or developing new capacity. Potential users include owners, operators, plant managers, and design engineers who are involved in selecting low-emission boilers and combustion equipment that comply with established emissions requirements. Regulatory authorities who deal with emission issues and boiler permit applications may also find useful information in the guide.

The guide is organized into topics that address many of the fundamental concerns encountered in planning a new steam or hot water boiler system. An overview of boilers, fuel feed systems, fuels, and emissions, which are fundamental considerations in the planning process, is presented in the first part of the guide. Discussions about firetube, watertube, cast iron, and tubeless boilers that burn fossil or non-fossil fuels are presented in Chap. 2. Technical terms and emission control techniques introduced in the overview provide a foundation for following discussions.

Issues pertaining to solid, liquid, and gaseous fuels commonly fired in ICI boilers are presented in the first part of Chap. 3. Characteristics of fossil and nonfossil fuels are included with emphasis on coal, oil, natural gas, biomass, and refuse-derived fuels (RDFs). For completeness, other materials such as heavy residuals from petroleum-cracking processes, coal tar pitch, and pulp mill sludge, which are sometimes used as boiler fuel, are briefly described. Following the fuel discussions, emphasis shifts to solid and gaseous emissions that are regulated under the Clean Air Act (CAA). The four principle emissions from combustion boilers that are regulated under this act include nitrogen oxides (NO_x), sulfur dioxide (SO_2), particulate matter (PM), and carbon monoxide (CO). Mechanisms by which these emissions are formed are briefly described as an aid in understanding the various control techniques for reducing emissions.

The legal basis for regulating emissions from combustion boilers is contained in the CAA. This piece of environmental legislation addresses concerns about ground-level ozone, the accumulation of fine particles in the atmosphere, and acid rain. It also authorizes EPA to establish performance-based emissions standards for certain air pollutants including NO_x , SO_2 , PM, and CO. A summary of emission limitations that are applicable to combustion boilers is presented in Appendix A. These limitations are specified as (1) maximum emission rates or (2) required reductions in potential combustion concentrations. Although the mandated emission limitations are a function of boiler type and size, the amount of each emission that may be released is strongly influenced by the type of fuel or fuel mixture being burned, the method of combustion, and the geographical location of the installation. In addition to

discussions about the CAA, other topics covered in Chap. 4 include information sources, permitting issues, and lessons learned.

Techniques that are effective in reducing NO_x, SO₂, and PM emissions are subdivided into three general categories, depending on which stage in the combustion process they are applied. The categories include precombustion, combustion, and postcombustion emission control techniques. Table ES.1 shows the various techniques that may be applied to reduce these emissions. Descriptions of each technique are presented in Chap. 5.

As an aid in boiler and combustion equipment selection, emission control options for 14 of the most popular boiler and fuel combinations are identified and discussed in Chap. 6. These options reflect combustion of coal, fuel oil, natural gas, biomass, and RDF in watertube and firetube boilers. Figure ES.1 presents the general format used to identify the various emission control options that are available for a particular boiler and fuel combination. Use of information presented in the tables will help ensure that the best available control technologies are identified.

Although many factors must be considered when selecting a low-emission boiler and combustion equipment, the final choice should not be made until the performance of the complete system is evaluated and understood. Evaluations of different emission control equipment arranged in various configurations

Table ES.1. Emission control techniques discussed in the guide

Emission	Control technique		
	Precombustion	Combustion	Postcombustion
Nitrogen oxide (NO _x)	Switch to fuel with a low nitrogen content	Operational modifications: <ul style="list-style-type: none"> oxygen trim (OT) burner tuning (BT) low excess air (LEA) Staged combustion air (SCA): <ul style="list-style-type: none"> burners out of service (BOOS) biased firing (BF) overfire air (OFA) Steam or water injection (SI/WI) Flue gas recirculation (FGR) Fuel-induced recirculation (FIR) Low-NO _x burner (LNB) Ultra low-NO _x burner (ULNB) Natural gas reburning (NGR) Reducing air preheat (RAP)	Selective catalytic reduction (SCR) Selective noncatalytic reduction (SNCR)
Sulfur dioxide (SO ₂)	Switch to fuel with a low-sulfur content Perform beneficiation	For fluidized-bed combustion (FBC) boilers, use limestone or dolomite as a sulfur-capture sorbent	Flue gas desulfurization (FGD): <ul style="list-style-type: none"> nonregenerative techniques regenerative techniques
Particulate matter (PM)	Switch to fuel with a low-ash content Perform beneficiation	Make operational modifications to reduce unburned carbon	Cyclone separator Wet scrubber Electrostatic precipitator (ESP) Fabric filter (baghouse)

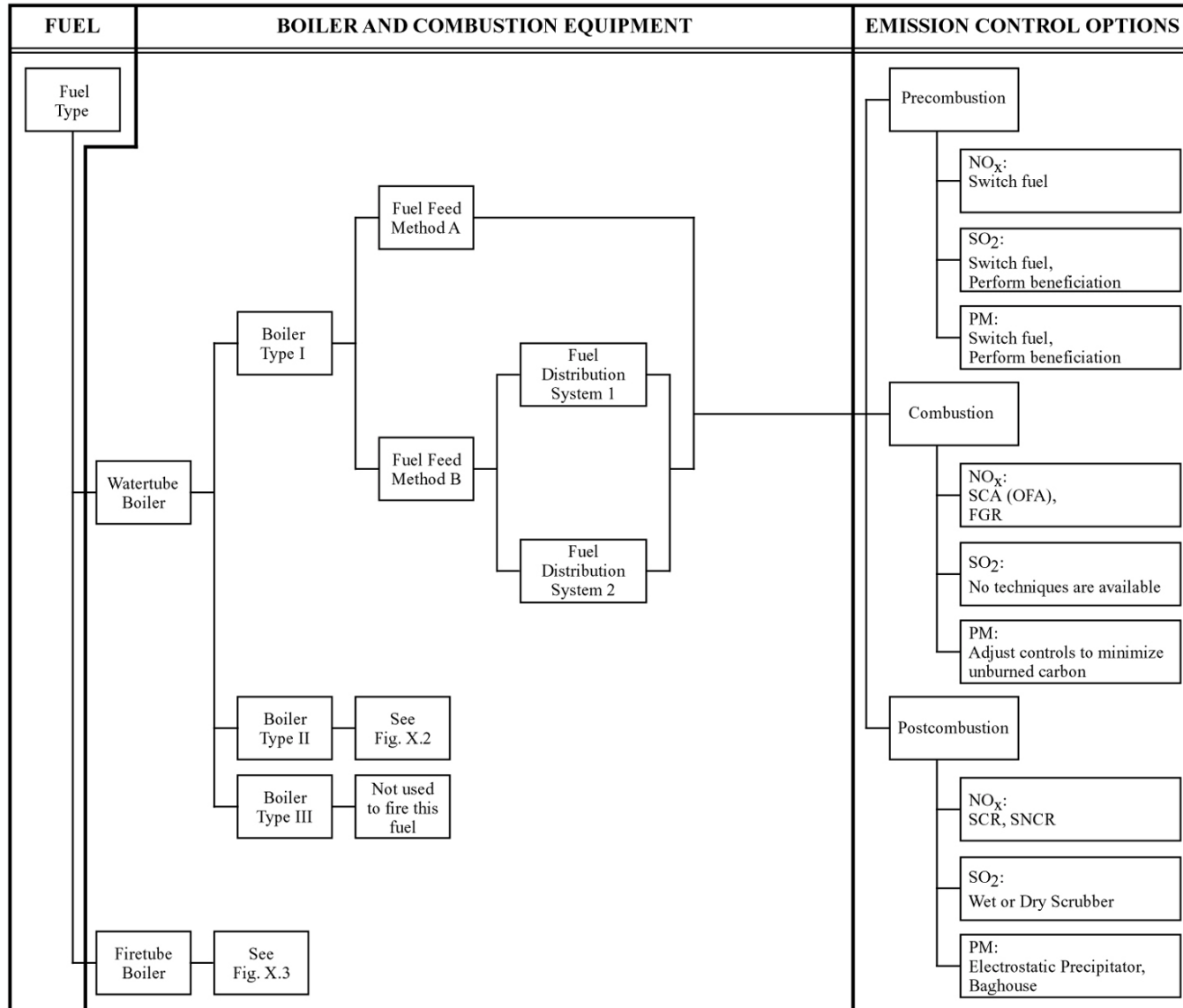

Fig. ES.1. Format used to present emission control options for various fuel and boiler combinations.

are technically complex. However, results of these evaluations are now an essential element of the permitting process. Details of the evaluations often establish the technical basis for permit applications submitted to regulatory authorities as part of the permitting process. Unless these evaluations are accurate and complete and unless currently accepted techniques for controlling emissions are adequately taken into consideration, it is unlikely that the regulatory authority will act favorably on the application. Information presented in this guide is intended to help owners and operators prepare permit applications that address the principal concerns and legal requirements of the regulatory authority.

References cited throughout the guide are listed for each chapter and also compiled in a bibliography. Information from these references was used to develop the text and tables that appear in the guide. The bibliography is provided to help identify useful resources for acquiring knowledge or technical details about a specific subject.

1. INTRODUCTION

Boiler owners and operators who need additional generating capacity face a number of legal, political, environmental, economic, and technical challenges. Their key to success requires selection of an adequately sized low-emission boiler and combustion equipment that can be operated in compliance with emission standards established by state and federal regulatory agencies. This guide presents a broad overview of technical and regulatory issues that may be encountered at various points in the selection process.

Information in the guide is primarily applicable to new industrial, commercial, and institutional (ICI) boilers and combustion equipment that must comply with emission requirements in the Clean Air Act (CAA).¹ These boilers are designed to use the chemical energy in fuel to raise the energy content of water so that it can be used for heating and power applications. Industrial boilers are used extensively in the chemical, food processing, paper, and petroleum industries. Commercial and institutional boilers are used in many other applications, including commercial businesses, office buildings, apartments, hotels, restaurants, hospitals, schools, museums, government buildings, and airports.

Use of the guide is primarily intended for those involved in either expanding current steam or hot water generating capacity or developing new capacity. Potential users include owners, operators, plant managers, and design engineers who are involved in the selection process. Regulatory authorities that deal with emission issues and boiler permit applications may also find the guide useful.

The guide was prepared at the Oak Ridge National Laboratory (ORNL) for the U.S. Department of Energy (DOE) through the Office of Industrial Technologies (OIT). To ensure that the guide covers a broad range of technical and regulatory issues of particular interest to the commercial boiler industry, the guide was developed in cooperation with the American Boiler Manufacturers Association (ABMA), the Council of Industrial Boiler Owners (CIBO), and the U.S. Environmental Protection Agency (EPA).

1.1 SCOPE AND OBJECTIVES

Information is presented for a broad class of steam and hot-water generating units known as ICI boilers. General discussions about commercially available ICI boilers are provided as well as information about the fuels that they burn and the emissions that they release. Discussions on environmental regulations, including emissions standards and compliance issues, technical details related to emission control techniques, and important considerations for combustion equipment selection, are also presented.

Emissions from ICI boilers that are currently regulated under the CAA are addressed in detail. These emissions, which include nitrogen oxides (NO_x), sulfur dioxide (SO₂), carbon monoxide (CO), and particulate matter (PM), are released whenever certain fossil and nonfossil fuels are burned. For discussion purposes, techniques for reducing these emissions from ICI boilers are subdivided into three categories: precombustion, combustion, and postcombustion emission control techniques. Although emission requirements for toxic air pollutants, which are also regulated under the CAA, have only been established for large municipal waste combustion units, a brief discussion about these pollutants is provided because emissions from combustion boilers may soon be regulated. Other important topics such as selection of process control instrumentation and emissions monitoring systems, which are key functional elements in new low-emission boiler installations, are not specifically addressed in this guide.

The primary objectives of the guide are to (1) present a broad range of issues that should be considered during the selection of new low-emission ICI boilers and combustion equipment and (2) identify information sources that contain relevant technical details. The guide is not intended to serve as a step-by-step design, procurement, or operations manual, nor is it considered a state-of-the-art report on combustion technology. Although information in the guide is primarily applicable to new ICI boilers, it may also apply to existing boiler installations. Issues pertaining to the selection of heat recovery steam generators or gas turbines are beyond the scope of the guide. Additional discussions about important boiler topics are presented in documents prepared by ABMA, CIBO, and DOE.²⁻⁵

1.2 APPROACH

Information is organized into topics that address many of the fundamental concerns encountered in planning a new steam or hot water boiler system that must comply with established emission standards. An overview of boilers, fuels, and emissions, which are fundamental considerations in the planning process, is presented immediately after the introduction. Terms and emission control concepts introduced in the overview provide a foundation for following discussions.

Chapter 2 focuses on the various types of ICI boilers that are commercially available. Emphasis is placed on firetube and watertube boilers although some discussion about other types of boilers, including cast iron and tubeless boilers, is also provided. Descriptions of solid, liquid, and gaseous fuels commonly fired in ICI boilers are presented in the first part of Chap. 3. Characteristics of fossil and nonfossil fuels are included with emphasis on coal, oil, natural gas, biomass, and refuse-derived fuels (RDFs). For completeness, other materials such as heavy residuals from petroleum-cracking processes, coal tar pitch, and pulp mill sludge, which are sometimes used as boiler fuel, are briefly described. Following the fuel discussions, emphasis shifts to solid and gaseous emissions that are regulated under the CAA.¹ Mechanisms by which these emissions are formed are briefly described as an aid in understanding the various emission control techniques that can be used to reduce emissions. Finally, the topic of efficiency is discussed. Efficiency is an important selection consideration because extracting as much energy from the fuel as possible is an effective way to reduce the total amount of emissions that are released.

The legal basis for regulating emissions from combustion boilers is contained in the CAA.¹ Discussions in Chap. 4 focus on this complex piece of environmental legislation that addresses concerns about ground-level ozone, the accumulation of fine particles in the atmosphere, hazardous air pollutants (HAPs), and acid rain. It also authorizes EPA to establish performance-based emissions standards for a broad list of pollutants. Federal emission limitations that are currently applicable to combustion boilers are tabulated in Appendix A. These limitations are specified as (1) maximum emission rates or (2) required reductions in potential combustion concentrations. Although the mandated emission limitations are a function of boiler type and size, the amount of each emission that may be released is strongly influenced by the type of fuel or fuel mixture being burned, the method of combustion, and the geographical location of the installation.

Techniques for reducing emissions before, during, and after combustion are presented in Chap. 5. Emission reductions can sometimes be achieved by switching to a different fuel or treating the fuel prior to combustion. As an example, SO₂ emissions from coal combustion can often be reduced by using low-sulfur instead of high-sulfur coal or by removing materials such as pyrites from the coal before it is fed into the boiler. Although these two precombustion emission control techniques are sometimes very effective, meaningful reductions generally require outfitting a boiler with special combustion equipment designed to implement a particular emissions control strategy. Reductions can be achieved by using an emission control technique that keeps the emission from forming during combustion or removes it after combustion has occurred.

These approaches to emissions reduction are reflected in the guidelines for selecting low-emission boilers and combustion equipment presented in Chap. 6. Discussions in this chapter focus on ICI boilers that burn various types of fuel and identify precombustion, combustion, and postcombustion emission control techniques that should be considered. As an aid in boiler and combustion equipment selection, emission control options for 14 of the most popular boiler and fuel combinations are identified. These options reflect combustion of coal, fuel oil, natural gas, biomass, and RDF in watertube and firetube boilers. Use of this information will help ensure that the best available control technologies (BACTs) are identified.

References cited throughout the guide are listed for each chapter and also compiled in a bibliography. Information from these references was used to develop the text and tables that appear in the guide. The bibliography represents another resource that may be useful in acquiring knowledge or technical details about a specific subject.

1.3 REFERENCE

1. "Clean Air Act," U.S. Environmental Protection Agency. <http://www.epa.gov/oar/caa/contents.html>
2. *Combustion Control Guidelines for Single Burner Firetube and Watertube Industrial/Commercial/Institutional Boilers*, American Boiler Manufacturers Association, Arlington, Virginia, 1999.
3. *Combustion Control Guidelines for Multiple Burner Boilers*, American Boiler Manufacturers Association, Arlington, Virginia, 2002.
4. *Energy Efficiency Handbook*, ed. R. A. Zeitz, Council of Industrial Boiler Owners, Burke, Virginia, November 1997.
5. G. Harrell, *Steam System Survey Guide*, ORNL/TM-2001/263, Oak Ridge National Laboratory, Oak Ridge, Tennessee, 2002.

2. INDUSTRIAL, COMMERCIAL, AND INSTITUTIONAL BOILERS

Combustion boilers are designed to use the chemical energy in fuel to raise the energy content of water so that it can be used for heating and power applications. Many fossil and nonfossil fuels are fired in boilers, but the most common types of fuel include coal, oil, and natural gas. During the combustion process, oxygen reacts with carbon, hydrogen, and other elements in the fuel to produce a flame and hot combustion gases. As these gases are drawn through the boiler, they cool as heat is transferred to water. Eventually the gases flow through a stack and into the atmosphere. As long as fuel and air are both available to continue the combustion process, heat will be generated.

Boilers are manufactured in many different sizes and configurations depending on the characteristics of the fuel, the specified heating output, and the required emissions controls. Some boilers are only capable of producing hot water, while others are designed to produce steam. Various studies have been conducted to estimate the number of boilers in the United States, but no data source provides a complete representation of the existing boiler population.¹

In the United States, boilers are typically designed and constructed as either power or heating boilers in accordance with applicable requirements adopted by the American Society of Mechanical Engineers (ASME). Rules for power boilers are provided in Sect. I of the *ASME Boiler and Pressure Vessel Code*.² These rules apply to steam boilers that operate above 15 psig and hot water boilers that operate above 160 psig or 250°F. Common design pressures are 150, 200, 250, and 300 psig, but higher pressures are possible.³ For example, boilers for certain pulp and paper industry applications are now designed for pressures as high as 1,500 psig. Corresponding rules for heating boilers are provided in Sect. IV.⁴ According to these rules, heating boilers that produce hot water are not allowed to operate above 160 psig or at temperatures above 250°F at or near the boiler outlet. Additional rules limit heating boilers that produce steam to a maximum operating pressure of 15 psig.

Many boilers with heat input capacities more than 250 million British thermal units per hour (MBtu/h) are classified as utility boilers because they are used at power plants to produce electricity. Some boilers of this size are also used at paper mills and institutions and for other industrial applications. Smaller boilers with less capacity are categorized as ICI boilers. Industrial boilers are used extensively by the chemical, food processing, paper, and petroleum industries. They have heat input capacities up to and sometimes more than 250 MBtu/h. Commercial and institutional boilers are used in many other applications including commercial businesses, office buildings, apartments, hotels, restaurants, hospitals, schools, museums, government buildings, and airports.

In the past when emissions were less regulated, choosing the right boiler and combustion equipment for a particular application generally involved matching the process requirements with the boiler's output capacity. Proper sizing and selection required knowledge of the peak process requirements and an understanding of the load profile. This boiler selection philosophy emphasized energy conversion at the lowest possible cost. Reduced emphasis was placed on controlling emissions. Public concerns about air and water quality and enactment of federal, state, and local regulations have shifted this emphasis. The current design objective is to provide low-cost energy with an acceptable impact on the environment. As discussed in an engineering manual published by ABMA, control of PM, NO_x, CO, and SO₂ emissions is now a significant consideration in the overall boiler and combustion equipment design and selection process.³

2.1 TYPES OF ICI BOILERS

Information in this guide focuses primarily on a broad class of steam and hot water generating units known as ICI boilers. Because of differences in their features and characteristics, ICI boilers can be classified in at least three ways.

- Boilers are commonly subdivided into watertube or firetube units. These designations reflect the way the water and combustion gases are designed to pass through the unit.
- Boilers are sometimes classified by their heat sources. For example, boilers are often referred to as oil-fired, gas-fired, coal-fired, or solid fuel-fired boilers. Coal-fired boilers can be further divided based on the equipment used to fire the boiler. The three major coal-fired boiler subclasses are pulverized-coal (PC) fired, stoker-fired, and fluidized-bed combustion (FBC) boilers.
- Boilers are occasionally distinguished by their method of fabrication. Packaged boilers are assembled in a factory, mounted on a skid, and transported to the site as one package ready for hookup to auxiliary piping. Shop-assembled boilers are built up from a number of individual pieces or subassemblies. After these parts are aligned, connected, and tested, the entire unit is shipped to the site in one piece. Field-erected boilers are too large to transport as an entire assembly. They are constructed at the site from a series of individual components. Sometimes these components require special transportation and lifting considerations because of their size and weight.

The basic purpose of any ICI boiler is to convert the chemical energy in fuel into thermal energy that can be used to generate steam or hot water. Inside the combustion chamber, two fundamental processes must occur to achieve this objective. First, the fuel must be mixed with sufficient oxygen to allow sustained combustion. The heated gases produced by the combustion process must then transfer the thermal energy to a fluid such as water or steam. Various components inside the boiler are required to promote efficient combustion and heat transfer. Their design depends on factors such as the type of fuel and the method selected to transfer thermal energy.

The ICI boilers are manufactured in a wide range of sizes to burn coal, oil, natural gas, biomass, and RDFs as well as other fuels and fuel combinations. Most ICI boilers are classified as either watertube or firetube boilers, but other designs such as cast iron, coil-type, and tubeless (steel shell) boilers are also produced. Descriptions of some of the more typical boiler designs are presented below. Additional details about ICI boilers and their design, construction, and operation are available from other sources.^{3,5-7}

2.1.1 Firetube Boilers

Firetube boilers consist of a series of straight tubes that are housed inside a water-filled outer shell. The tubes are arranged so that hot combustion gases flow through the tubes. As hot gases flow through the tubes, they heat the water that surrounds the tubes. The water is confined by the outer shell of the boiler. To avoid the need for a thick outer shell, firetube boilers are used for lower-pressure applications. Generally, the heat input capacities for firetube boilers are limited to 50 MBtu/h or less,⁵ but in recent years the size of firetube boilers has increased.

Firetube boilers are subdivided into three groups. Horizontal return tubular (HRT) boilers typically have horizontal, self-contained firetubes with a separate combustion chamber. Scotch, Scotch marine, or shell boilers have the firetubes and combustion chamber housed within the same shell. Firebox boilers have a water-jacketed firebox and employ, at most, three passes of combustion gases. Boiler configurations for each type are shown in Figs. 2.1–2.3, respectively.

Most modern firetube boilers have cylindrical outer shells with a small round combustion chamber located inside the bottom of the shell. Depending on construction details, these boilers have tubes configured in either one, two, three, or four pass arrangements. Because the design of firetube boilers is simple, they are easy to construct in a shop and can be shipped fully assembled as a package unit. Table 2.1 identifies various types of firetube boilers and the associated fuels that they typically burn.

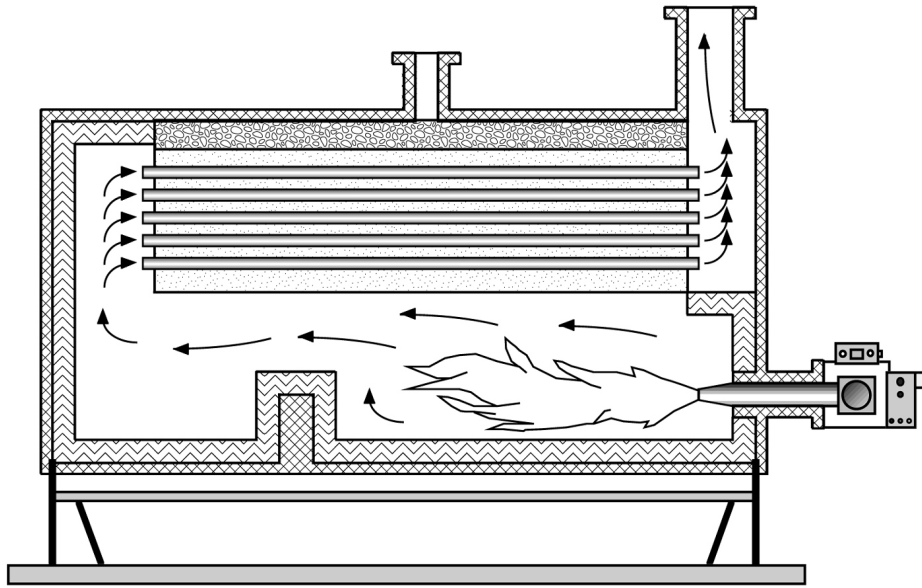

Fig. 2.1. Configuration of HRT firetube boiler.

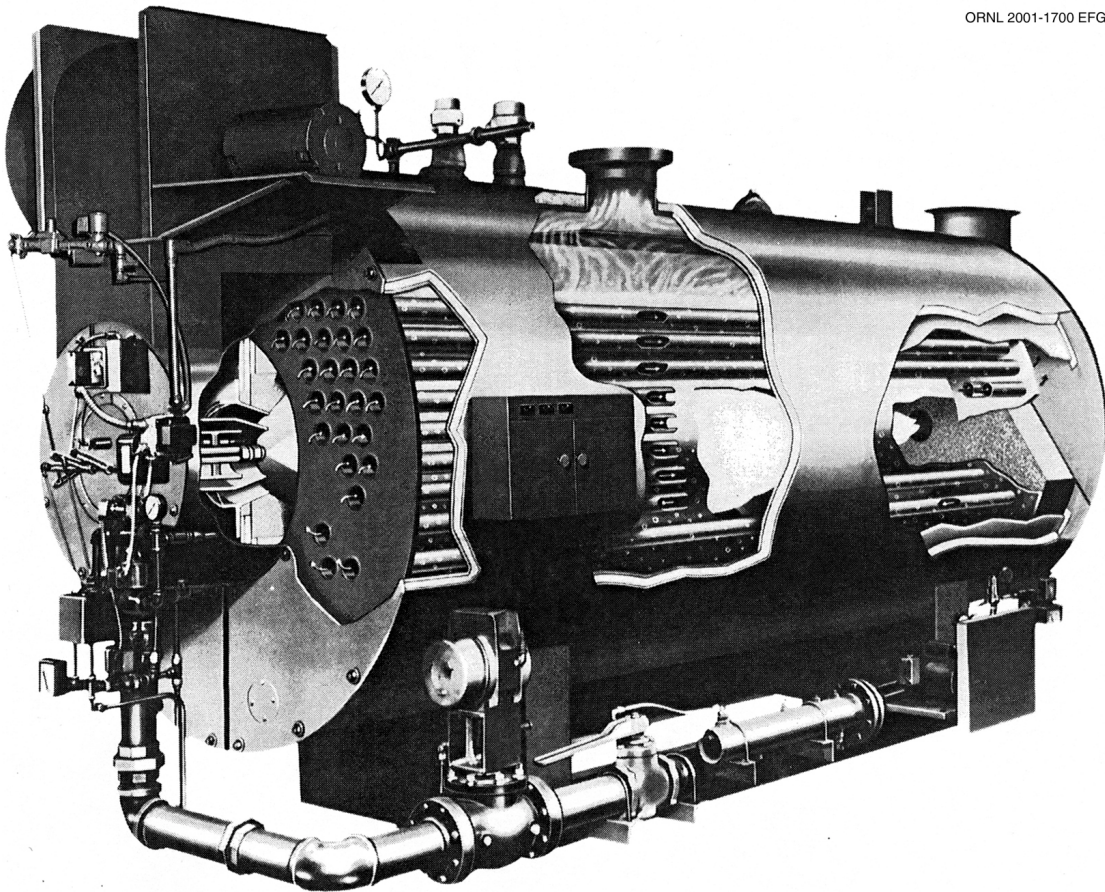

Fig. 2.2. Configuration of Scotch package firetube boiler. *Source:* Reprinted from Ref. 6.

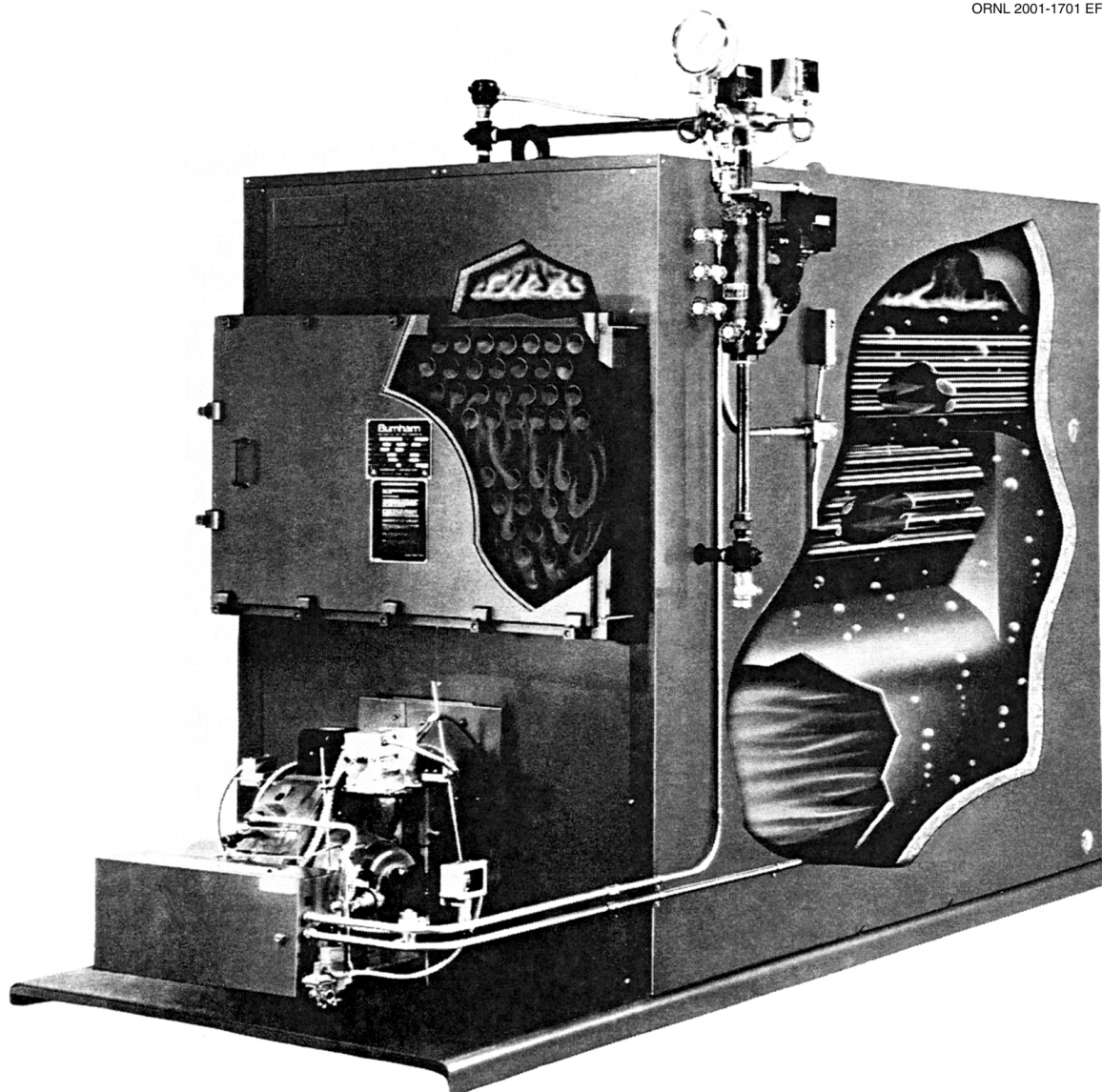

Fig. 2.3. Configuration of firebox firetube boiler. *Source:* Reprinted from Ref. 6.

Table 2.1. Fuels typically fired in ICI firetube boilers

Firetube boiler type	Fuel				
	Coal	Fuel oil	Natural gas	Biomass	Refuse-derived
HRT boilers	Yes	Yes	Yes	Yes	Yes
Scotch boilers	Yes	Yes	Yes	No	No
Firebox boilers	Yes	Yes	Yes	Yes	Yes

2.1.2 Watertube Boilers

Watertube boilers are designed to circulate hot combustion gases around the outside of a large number of water-filled tubes.⁸ The tubes extend between an upper header, called a steam drum, and one or more lower headers or drums. In older designs, the tubes are either straight or bent into simple shapes. Newer boilers have tubes with complex and diverse bends. Because the pressure is confined inside the tubes, watertube boilers can be fabricated in larger sizes and used for higher-pressure applications. Small watertube boilers, which have one and sometimes two burners, are generally fabricated and supplied as packaged units. Because of their size and weight, large watertube boilers are often fabricated in pieces and assembled in the field. Configurations for packaged and field-erected watertube boilers are shown in Figs. 2.4 and 2.5, respectively.

Almost any solid, liquid, or gaseous fuel can be burned in a watertube boiler. Common fuels include coal, oil, natural gas, biomass, and other solid fuels such as municipal solid waste (MSW), tire-derived fuel (TDF), and RDF. Designs of watertube boilers that burn these fuels can be significantly different. Various watertube boilers and the fuels that they commonly burn are identified in Table 2.2. Configurations of boilers for burning RDF, MSW, and other solid fuel are shown in Figs. 2.6–2.8 (Ref. 9).

Coal-fired watertube boilers are classified into three major categories: stoker-fired units, PC-fired units, and FBC boilers.

Stoker-fired boilers include a mechanical system that is designed to feed solid fuel into the boiler. These stokers are designed to support the combustion process and to remove the ash as it accumulates. All stokers operate similarly. They use both undergrate and overfire air to burn fuel located on a grate. Different designs for stokers are described in Sect. 2.2.1.

The PC-fired boilers are generally large field-erected units such as the one shown in Fig. 2.9. During operation, finely ground coal is mixed with primary combustion air and fed to the burner or burners where it ignites. Secondary combustion air is then supplied to complete the combustion process. Depending on the location of the burners and the direction of coal injection, PC-fired boilers can be classified as single- or opposed-wall, tangential (corner), or cyclone boilers. Discussions about burners for PC-fired boilers are provided in Sect. 2.2.2. Depending on whether the ash is removed in a solid or

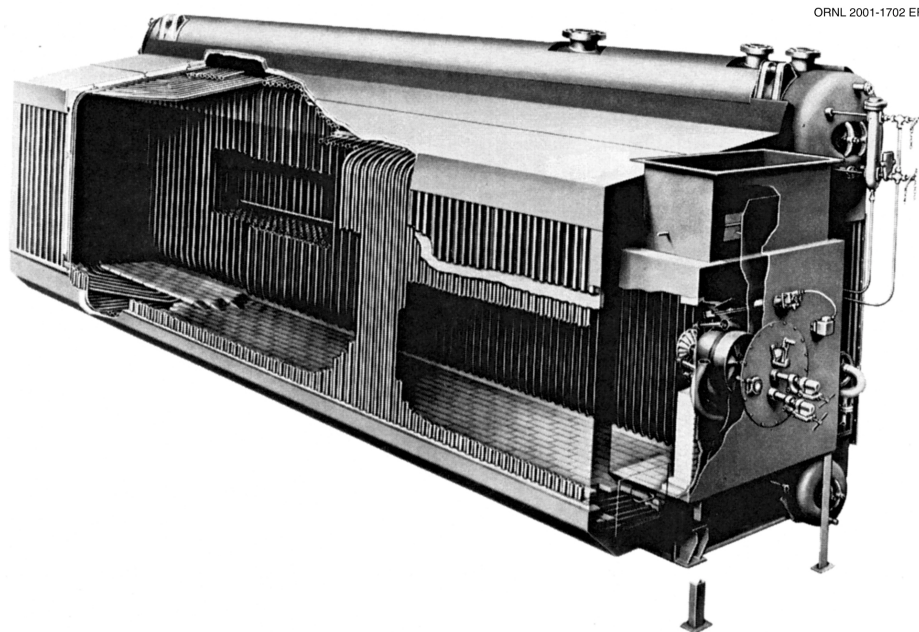

Fig. 2.4. Configuration of package watertube boiler. *Source:* Reprinted from Ref. 6.

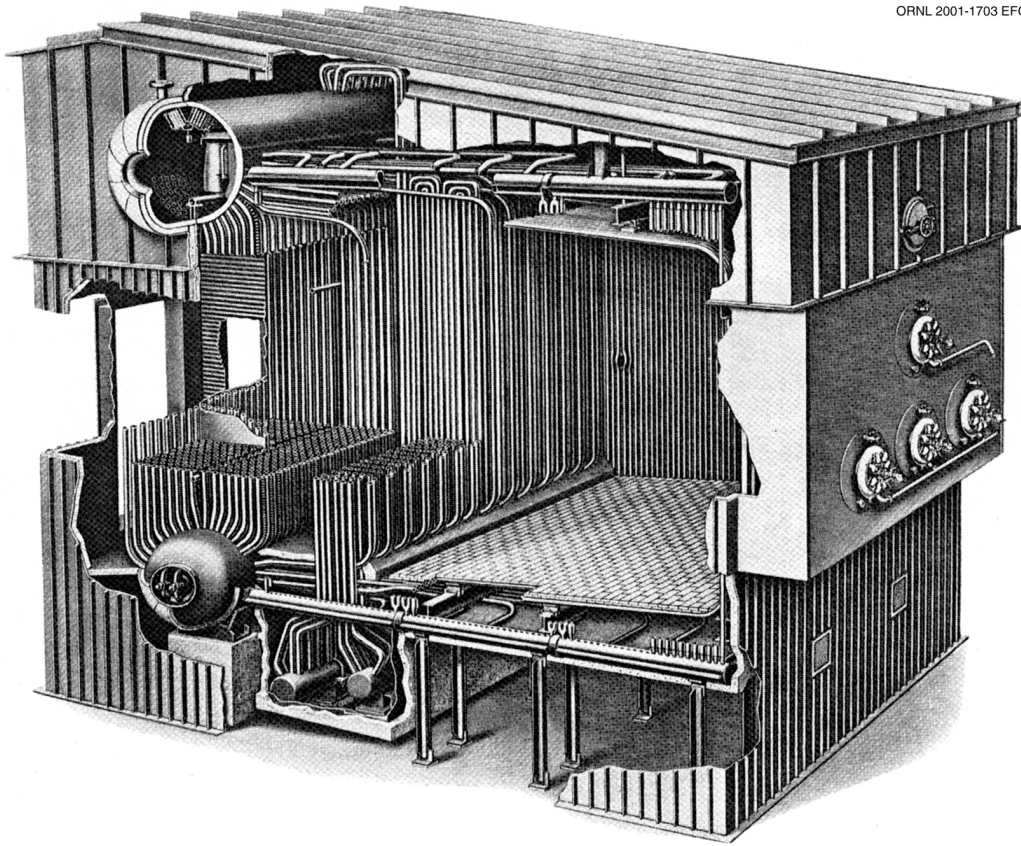

Fig. 2.5. Configuration of field-erected watertube boiler. *Source:* Reprinted from Ref. 6.

Table 2.2. Fuels typically fired in ICI watertube boilers

Watertube boiler	Fuel				
	Coal	Fuel oil	Natural gas	Biomass	Refuse-derived
Stoker-fired boilers	Yes for boilers with the following types of stokers	No	No	Yes for boilers with the following types of stokers	Yes for boilers with the following types of stokers
Underfeed stokers					
<ul style="list-style-type: none"> • Horizontal feed side-ash discharge • Gravity feed rear-ash discharge 					
Overfeed stokers					
<ul style="list-style-type: none"> • Mass feed <ul style="list-style-type: none"> ✓ Water-cooled vibrating grate ✓ Moving (chain and traveling) grate • Spreader <ul style="list-style-type: none"> ✓ Traveling grate ✓ Air-cooled vibrating grate ✓ Water-cooled vibrating grate 					
PC-fired boilers	Yes for the following types of PC-fired boilers	<i>a</i>	<i>a</i>	No	No
<ul style="list-style-type: none"> • Single or opposed-wall • Tangential (corner) • Cyclone 					
FBC boilers	Yes for the following types of FBC boilers	<i>a</i>	<i>a</i>	Yes for the following types of FBC boilers	Yes for the following types of FBC boilers
<ul style="list-style-type: none"> • Atmospheric <ul style="list-style-type: none"> ✓ Bubbling ✓ Circulating • Pressurized 					
Package boilers	No	Yes for the following types of package boilers	Yes for the following types of package boilers	No	No
<ul style="list-style-type: none"> • “A” • “D” • “O” 					

^aGas or oil is often used at start-up.

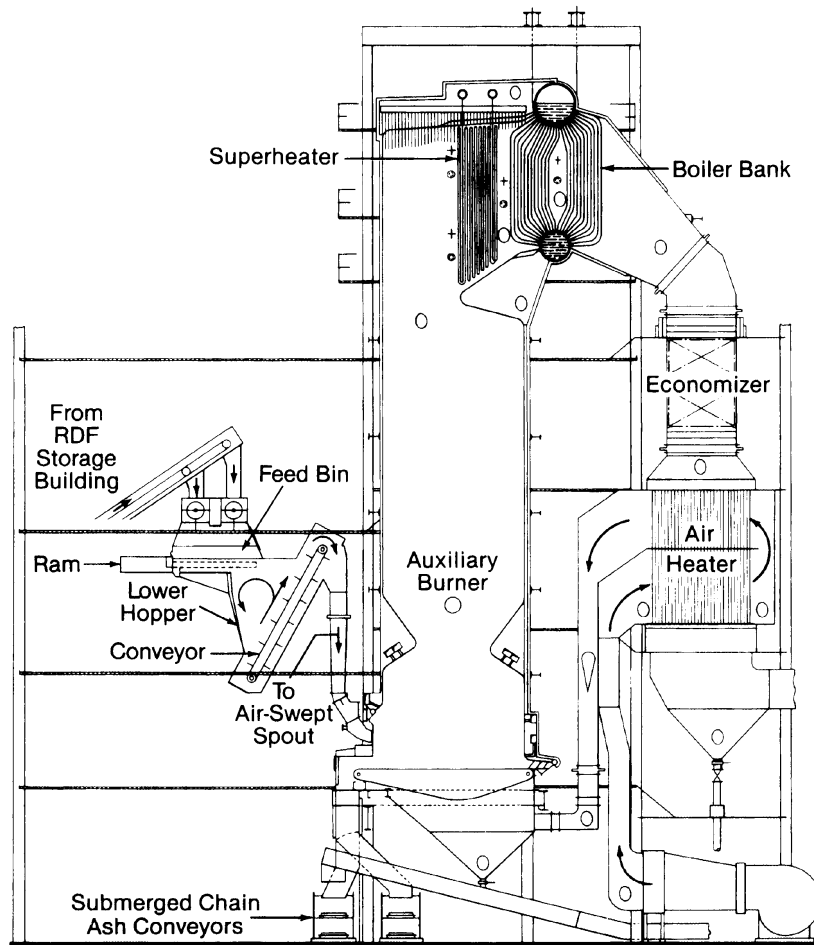

Fig. 2.6. Configuration of watertube boiler for burning RDF. *Source:* Reprinted from Ref. 9.

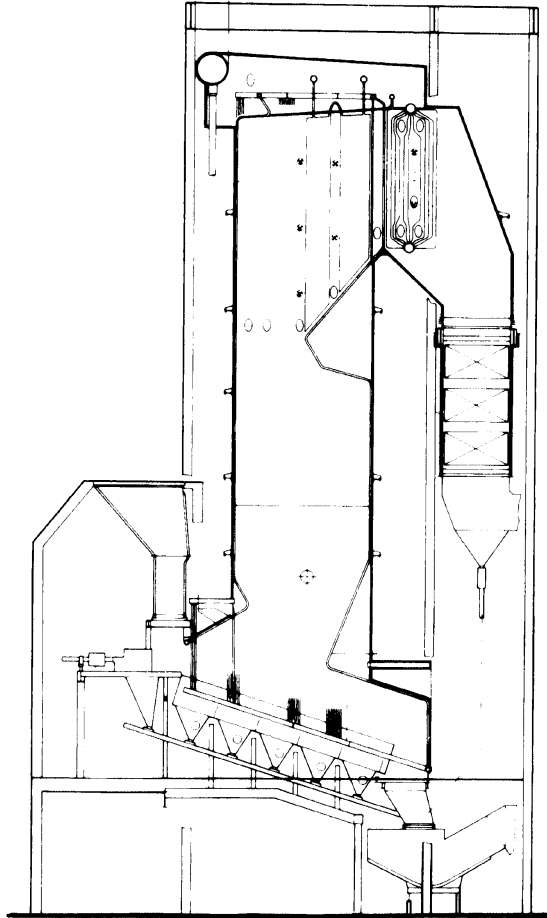

Fig. 2.7. Configuration of watertube boiler for burning MSW. *Source:* Reprinted from Ref. 9.

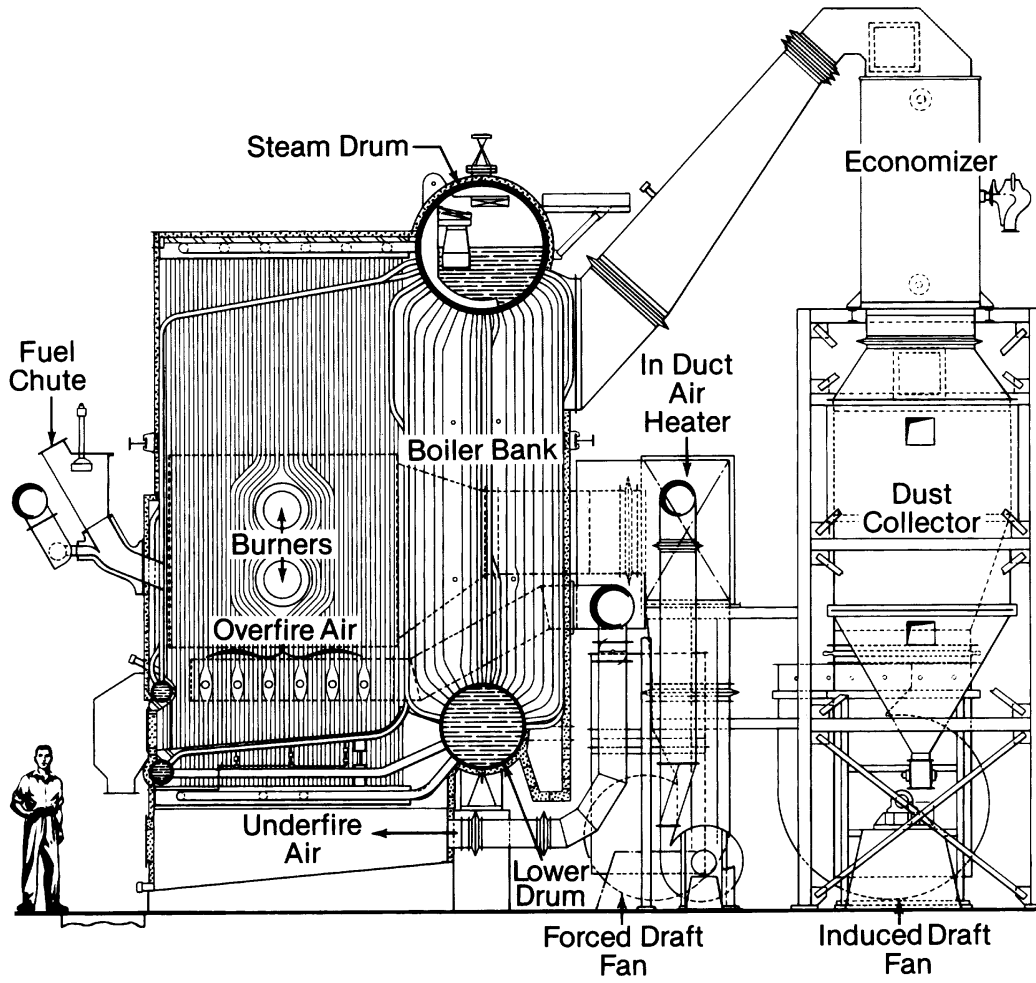

Fig. 2.8. Configuration of watertube boiler for burning solid fuel such as wood, biomass, or stoker coal.
 Source: Reprinted from Ref. 9.

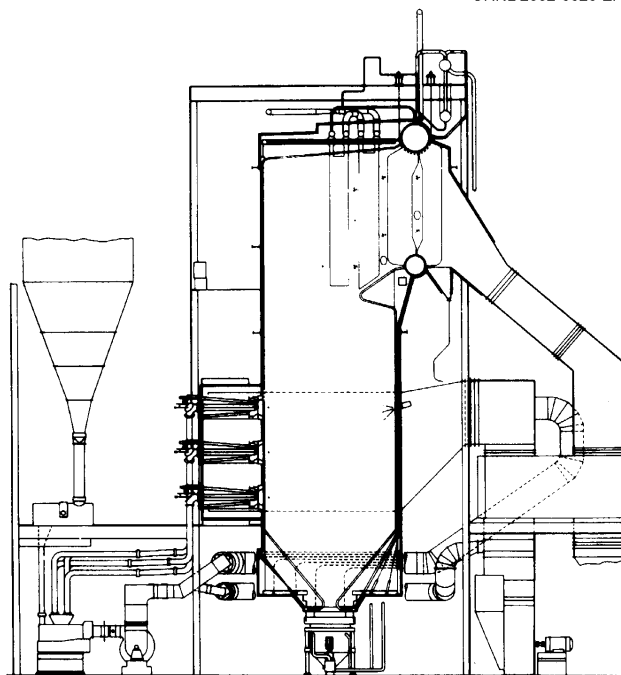

Fig. 2.9. Configuration of watertube boiler for burning PC. *Source:* Reprinted from Ref. 9.

molten state, PC-fired boilers are also classified as dry or wet bottom. Opposed-wall boilers are usually much larger than 250-MBtu/h heat input capacity. They are used primarily for utility but may be suitable for certain industrial applications. Coal burned in cyclone boilers is crushed rather than pulverized.

The FBC boilers are capable of burning a wide range of solid fuels. In this method of combustion, fuel is burned in a bed of hot incombustible particles suspended by an upward flow of fluidizing gas such as air. Fuels that contain a high concentration of ash, sulfur, and nitrogen can be burned efficiently while meeting stringent emission limitations. When sulfur capture is not required, inert materials such as alumina may be added to supplement the fuel ash and maintain the bed. In applications where sulfur capture is required, limestone is incorporated into the bed and used as the sorbent.¹⁰ The FBC boilers are categorized as either atmospheric or pressurized units. Atmospheric FBC boilers are further divided into bubbling-bed and circulating-bed units; the fundamental difference between these two is the fluidization velocity. Coal is often burned in FBC boilers, but it is also possible to burn biomass and other solid fuels. Natural gas or fuel oil is used primarily as a start-up fuel to preheat the fluidized bed or as an auxiliary fuel when additional heat is required. Configurations of various types of FBC boilers are shown in Figs. 2.10–2.12.

Combustion of other solid fuels, including MSW and RDF, is often accomplished in a boiler with a stoker system. Fuels of this type generally have specially designed feed systems for supplying and distributing the fuel particles. Boilers that burn these fuels are also specially designed to interface with the fuel feed system and to burn the fuel as efficiently as possible. Many boilers that burn solid nonfossil fuels have some type of fossil fuel firing capability. These auxiliary fuels are used during start-up operations, as a supplementary fuel, or alone when the primary fuel is unavailable.

Nonfossil gaseous fuels that are rich in CO and hydrogen can also be burned in watertube boilers. These fuels can be generated by the partial combustion of biomass using gasification or pyrolysis techniques.

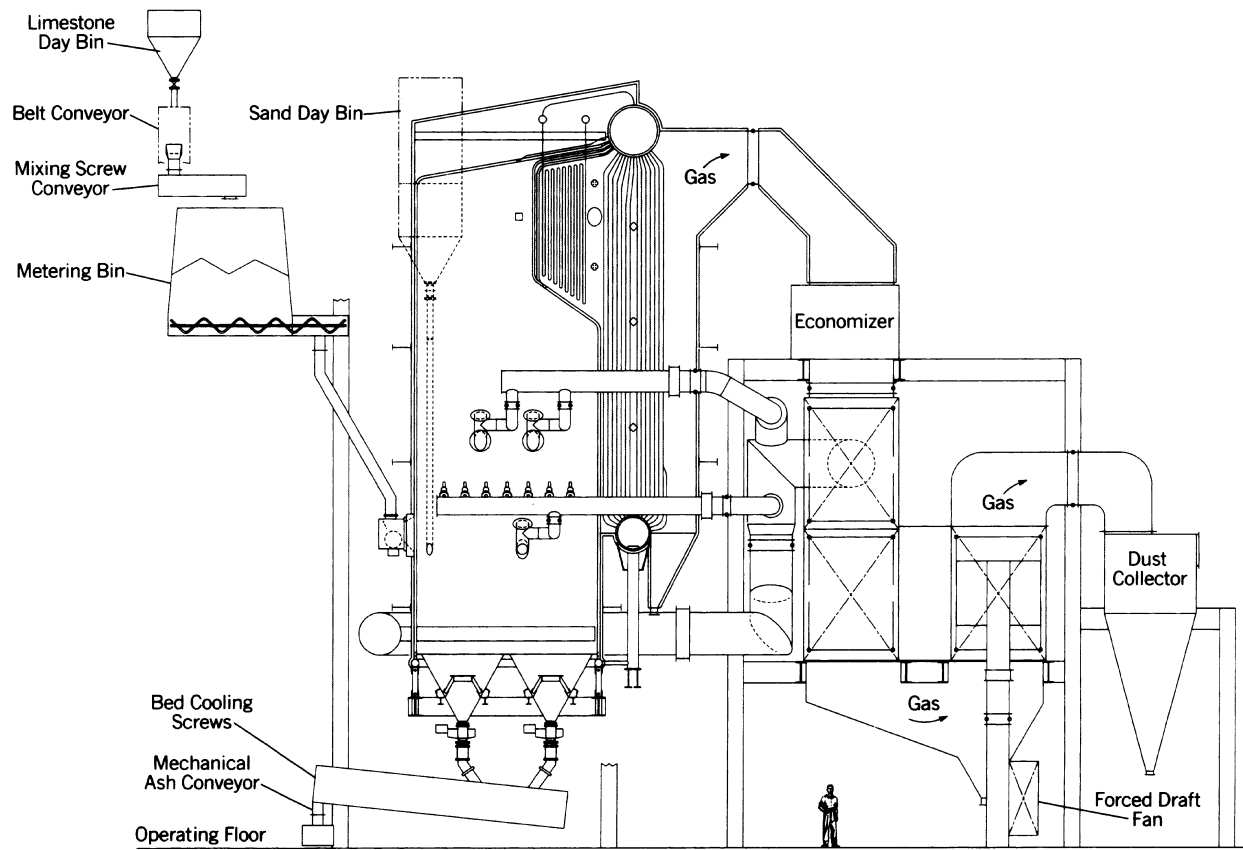

Fig. 2.10. Configuration of bubbling FBC watertube boiler. *Source:* Reprinted from Ref. 9.

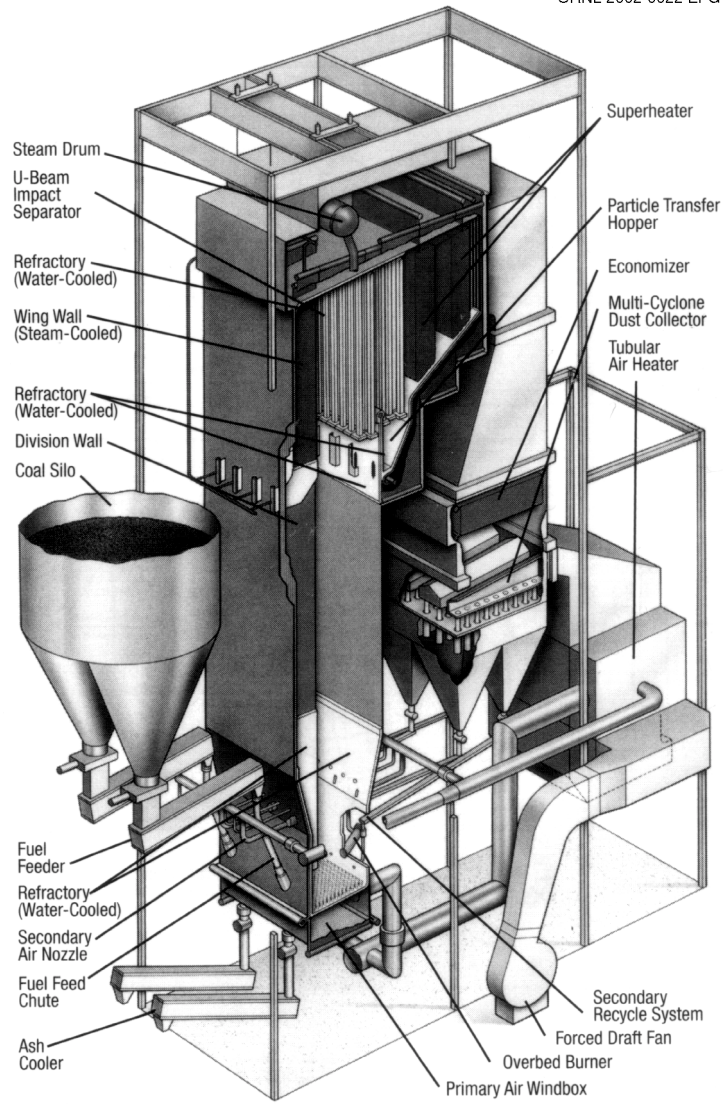

Fig. 2.11. Configuration of circulating FBC watertube boiler. *Source:* Reprinted from Ref. 9.

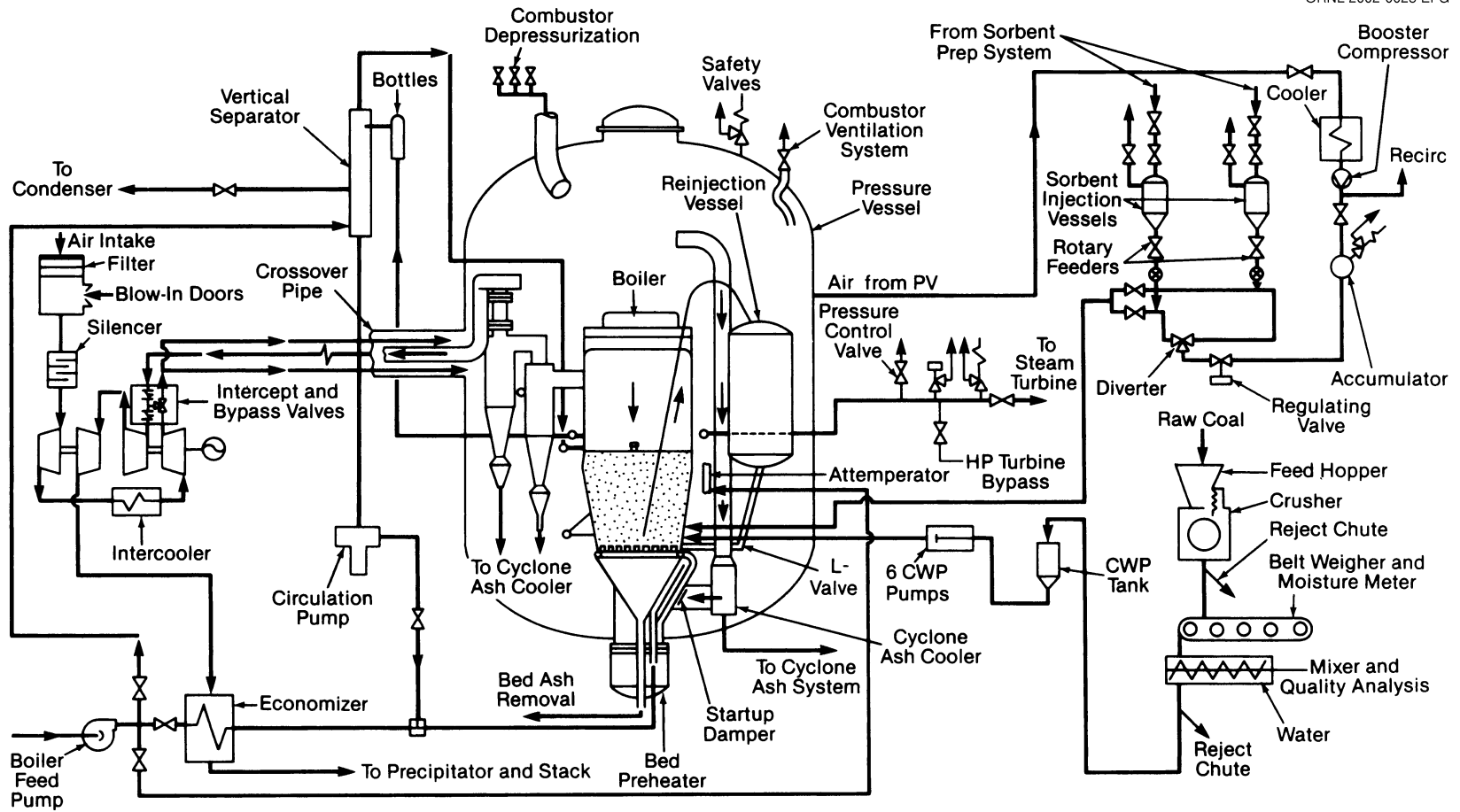

Fig. 2.12. Configuration of pressurized FBC boiler system. Source: Reprinted from Ref. 9.

Fuel oil-fired and natural gas-fired watertube package boilers are subdivided into three classes based on the geometry of the tubes. The “A” design has two small lower drums and a larger upper drum for steam-water separation. In the “D” design, which is the most common, the unit has two drums and a large-volume combustion chamber. The orientation of the tubes in a “D” boiler creates either a left- or right-handed configuration. For the “O” design, the boiler tube configuration exposes the least amount of tube surface to radiant heat. Rental units are often “O” boilers because their symmetry is a benefit in transportation. Figures 2.13–2.15 show tube configurations for each of these watertube package boiler designs.

ORNL 2001-1704 EFG

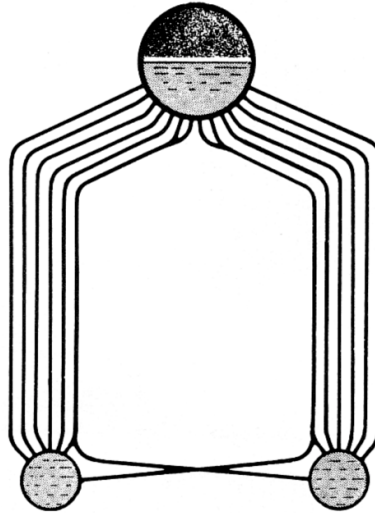

Fig. 2.13. Configuration of tubes for “A” package watertube boiler. *Source:* Reprinted from Ref. 11.

ORNL 2001-1705 EFG

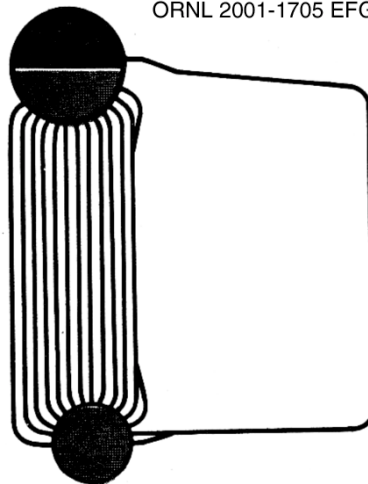

Fig. 2.14. Configuration of tubes for “D” package watertube boiler. *Source:* Reprinted from Ref. 11.

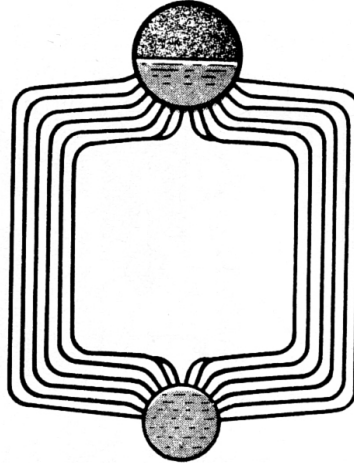

Fig. 2.15. Configuration of tubes for “O” package watertube boiler. *Source:* Reprinted from Ref. 11.

2.1.3 Other Combustion Boilers

Cast iron boilers are fabricated from a number of cast iron sections that are bolted together. The design of each section includes integral water and combustion gas passages. When fully assembled, the interconnecting passages create chambers where heat is transferred from the hot combustion gases to the water. These boilers generally produce low-pressure steam (15 psig) or hot water (30 psig) and burn either oil or natural gas. Only about 12% of the cast iron boilers in the United States are fired by coal.

Because of their construction, cast iron boilers are limited to smaller sizes. Only 37% have heat input capacities greater than 0.4 MBtu/h (Ref. 5). Because the components of these boilers are relatively small and easy to transport, they can be assembled inside a room with a conventional-size doorway. This feature means that cast iron boilers are often used as replacement units, which eliminate the need for temporary wall removal to provide access for larger package units. Cast iron boilers represent only about 10% of the ICI boiler capacity in the United States. The configuration of a cast iron boiler is shown in Fig. 2.16.

Another boiler that is sometimes used to produce steam or hot water is known as a tubeless boiler. The design of tubeless boilers incorporates nested pressure vessels with water located between the shells.⁵ Combustion gases are fired into the inner vessel where heat is transferred to water located between the outside surface of the inner shell and the inside surface of the outer shell. For oil-fired and natural-gas-fired vertical tubeless boilers, the burner is typically located at the bottom of the boiler and fires into the inner pressure vessel. The configuration of a vertical tubeless boiler is shown in Fig. 2.17.

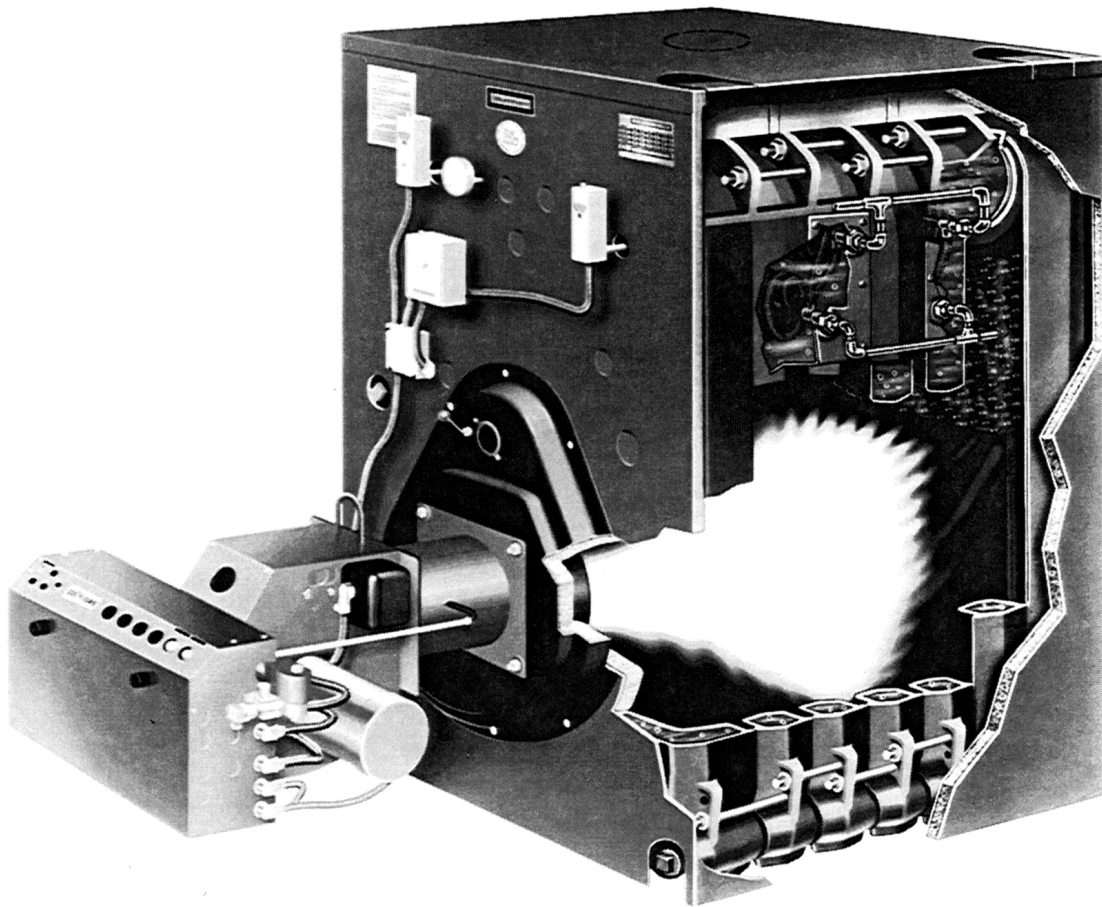

Fig. 2.16. Configuration of cast iron boiler. *Source:* Reprinted from Ref. 6.

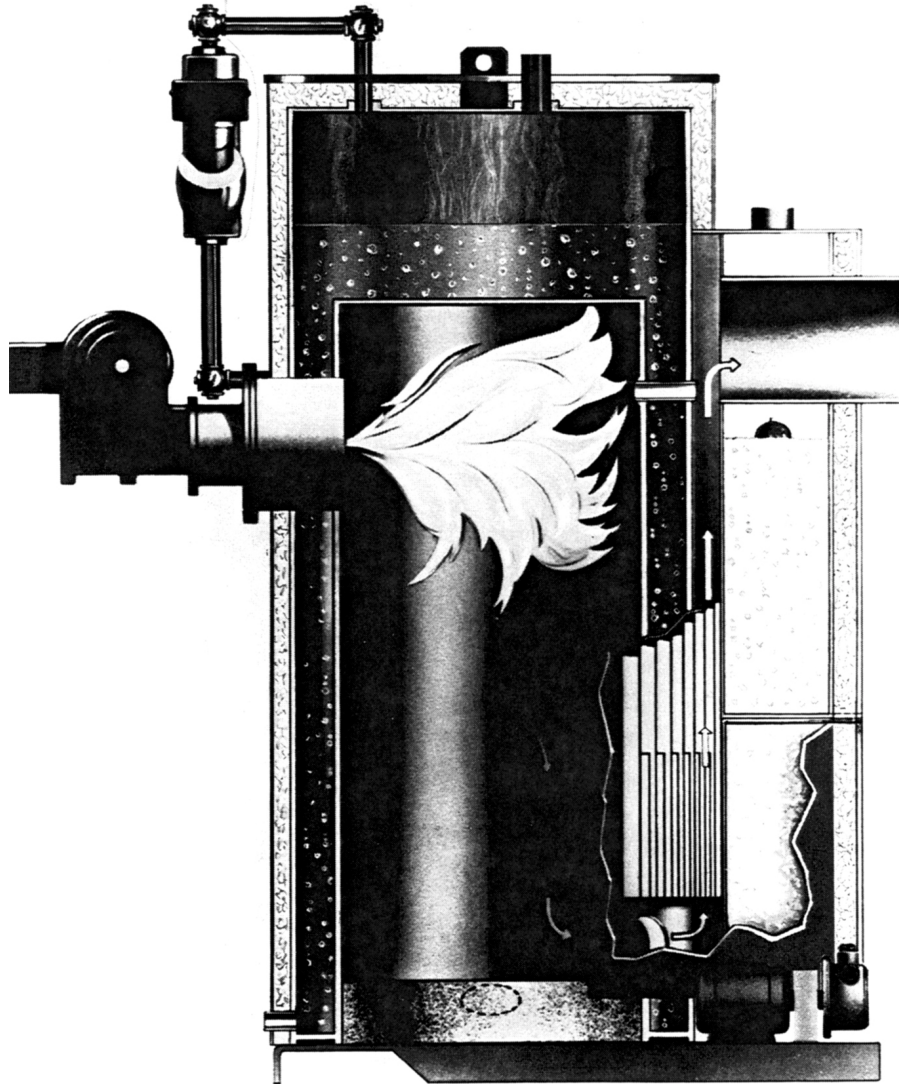

Fig. 2.17. Configuration of vertical tubeless boiler. *Source:* Reprinted from Ref. 6.

2.2 FUEL FEED SYSTEMS

Fuel feed systems play a critical role in the performance of low-emission boilers. Their primary functions include (1) transferring the fuel into the boiler and (2) distributing the fuel within the boiler to promote uniform and complete combustion. The type of fuel and whether the fuel is a solid, liquid, or gas influences the operational features of a fuel feed system.

Gaseous fuels are relatively easy to transport and handle. Any pressure difference will cause gas to flow, and most gaseous fuels mix easily with air. Because on-site storage of gaseous fuel is generally not feasible, boilers must be connected to a fuel source such as a natural gas pipeline. Flow of gaseous fuel to a boiler can be precisely controlled using a variety of control systems. These systems generally include automatic valves that meter gas flow through a burner and into the boiler based on steam or hot water demand. The purpose for the burner is to increase the stability of the flame over a wide range of flow rates by creating a favorable condition for fuel ignition and establishing aerodynamic conditions that ensure good mixing between the primary combustion air and the fuel. Burners are the central elements of

an effective combustion system. Other elements of their design and application include equipment for fuel preparation and air-fuel distribution as well as a comprehensive system of combustion controls.

Like gaseous fuels, liquid fuels are also relatively easy to transport and handle by using pumps and piping networks that link the boiler to a fuel supply such as a fuel oil storage tank. To promote complete combustion, liquid fuels must be atomized to allow thorough mixing with combustion air. Atomization by air, steam, or pressure produces tiny droplets that burn more like gas than liquid. Control of boilers that burn liquid fuels can also be accomplished using a variety of control systems that meter fuel flow.

Solid fuels are much more difficult to handle than gaseous and liquid fuels. Preparing the fuel for combustion is generally necessary and may involve techniques such as crushing or shredding. Before combustion can occur, the individual fuel particles must be transported from a storage area to the boiler. Mechanical devices such as conveyors, augers, hoppers, slide gates, vibrators, and blowers are often used for this purpose. The method selected depends primarily on the size of the individual fuel particles and the properties and characteristics of the fuel. Stokers are commonly used to feed solid fuel particles such as crushed coal, TDF, MSW, wood chips, and other forms of biomass into boilers. Mechanical stokers evolved from the hand-fired boiler era and now include sophisticated electromechanical components that respond rapidly to changes in steam demand. The design of these components provides good turndown and fuel-handling capability. In this context, turndown is defined as the ratio of maximum fuel flow to minimum fuel flow. Although stokers are used for most solid fuels, PC combustion, which consists of very fine particles, does not involve a stoker. Coal in this form can be transported along with the primary combustion air through pipes that are connected to specially designed burners.

The following discussions about stokers and burners are only intended to provide background information about these devices. Because the characteristics of stokers and burners are very complex and highly technical, the information does not address detailed issues associated with their design, construction, theory of operation, or performance. Because of concerns about revealing proprietary information, these discussions are intentionally generic in nature. Specific details about a particular product or design should be obtained from the manufacturer.

2.2.1 Stokers

Firing systems that involve stokers must be integrated into the overall boiler design to optimize combustion and heat recovery while minimizing unburned fuel and atmospheric emissions. Modern mechanical stokers consist of (1) a fuel admission system, (2) a stationary or moving grate assembly that supports the burning fuel and provides a pathway for the primary combustion air, (3) an overfire air (OFA) system that supplies additional air to complete combustion and minimize atmospheric emissions, and (4) an ash discharge system.¹² Stoker-firing systems are typically categorized as either underfeed or overfeed stokers.

2.2.1.1 Underfeed stokers

Underfeed stokers supply both fuel and primary combustion air from beneath the grate. The fuel is moved into a hopper and onto the grate by either a screw or ram-driven mechanism. As the fuel moves out over the grate where it is exposed to air and radiant heat, it begins to burn. During the combustion process, ash accumulates. To reduce the tendency for clinker formation, it is sometimes necessary to use moving grates that agitate the burning fuel bed. The two basic types of underfeed stokers are the (1) horizontal-feed, side-ash discharge type and (2) the less popular gravity-feed, rear-ash discharge type.¹² The cross section of an underfeed, side-ash discharge stoker is shown in Fig. 2.18. Because of cost and environmental considerations, the demand for underfeed stokers has diminished.

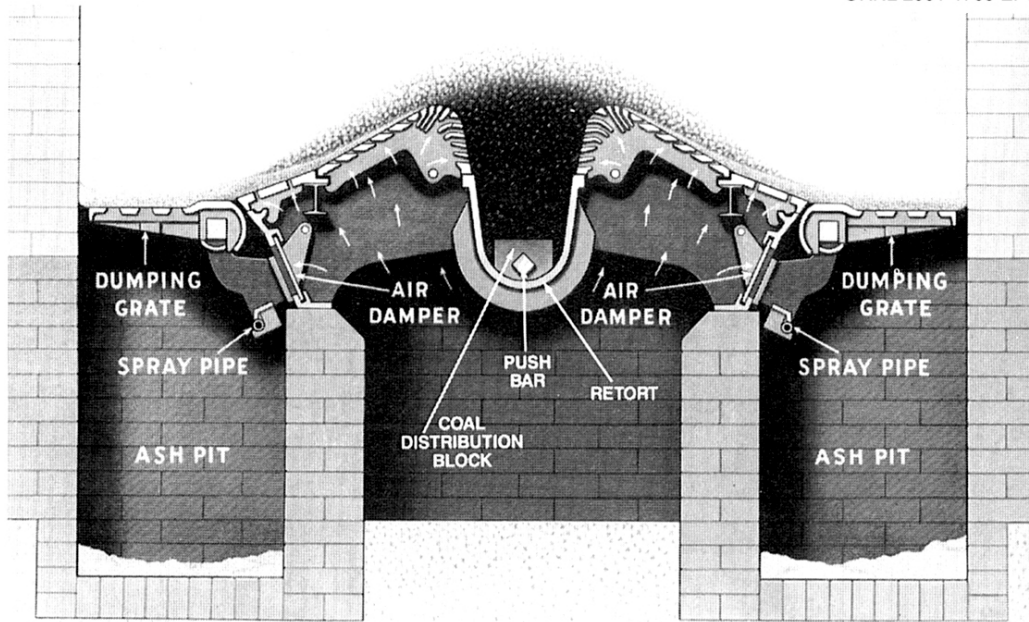

Fig. 2.18. Cross section of underfeed, side-ash discharge stoker. Source: Reprinted from Ref. 11.

2.2.1.2 Overfeed stokers

Overfeed stokers are generally classified as either mass-feed or spreader stokers. These designations reflect the way that the fuel is distributed and burned within the boiler.

Mass-feed stokers introduce fuel continuously at one end of a grate. As the fuel moves into the boiler, it falls onto the grate by gravity. The height of the fuel bed is controlled in two ways. A gate can be moved up or down to regulate the amount of fuel that is allowed to enter the boiler, and the speed at which the fuel moves beneath the grate can be adjusted. Inside the boiler, the fuel burns as it travels along the grate. Ash that forms and remains on the grate is discharged at the opposite end. Primary combustion air flows upward from beneath the grate and through the burning bed of fuel. The two primary mass-feed stokers are (1) water-cooled vibrating grate and (2) moving (chain and traveling) grate stokers.¹² Cross sections of (1) an overfeed, water-cooled, vibrating-grate, mass-feed stoker and (2) an overfeed, water-cooled, traveling-grate, mass-feed stoker are shown in Figs. 2.19 and 2.20, respectively.

Spreader stokers are very versatile and the most commonly used stoker. They are capable of distributing fuel evenly and to a uniform depth over the entire grate surface by using a device that propels the individual fuel particles into the air above the grate. Methods used to propel the fuel particles include air injection and underthrow and overthrow rotors. As the fuel is thrown into the boiler, fines ignite and burn in suspension. Because of suspension burning, response time of spreader stokers is better than mass-feed or underfeed stokers. The coarser particles fall onto the grate and burn in a thin bed. Primary combustion air is supplied from an air plenum located beneath the grate. The OFA ports supply the additional air that is needed to complete the combustion process. Grates for spreader stokers are generally designed to move rather than remain stationary. Traveling grates, air-cooled vibrating grates, and water-cooled vibrating grates are designs that have been used successfully. Cross sections of (1) an overfeed, traveling-grate, spreader stoker; (2) an overfeed air-cooled, vibrating-grate, spreader stoker;

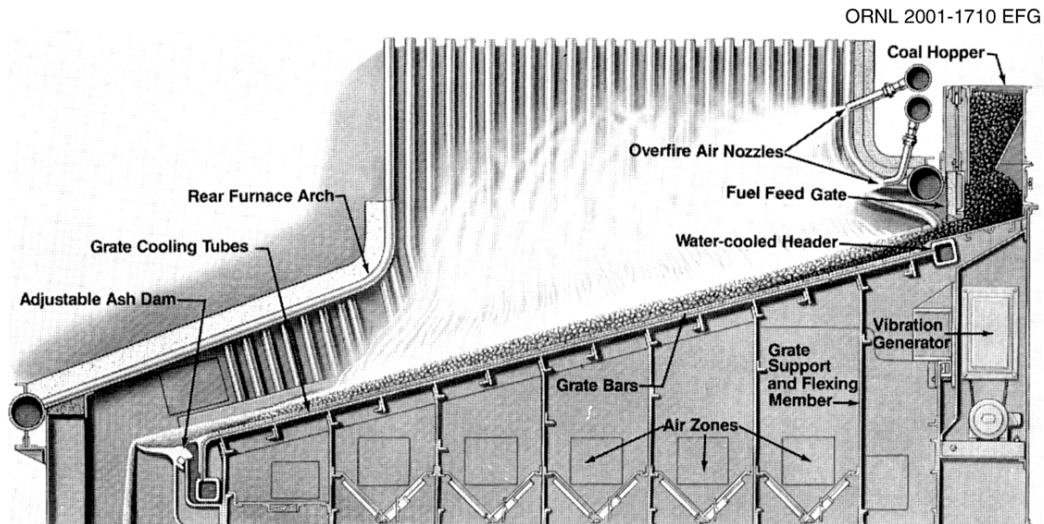

Fig. 2.19. Cross section of overfeed, water-cooled, vibrating-grate, mass-feed stoker. *Source:* Reprinted from Ref. 11.

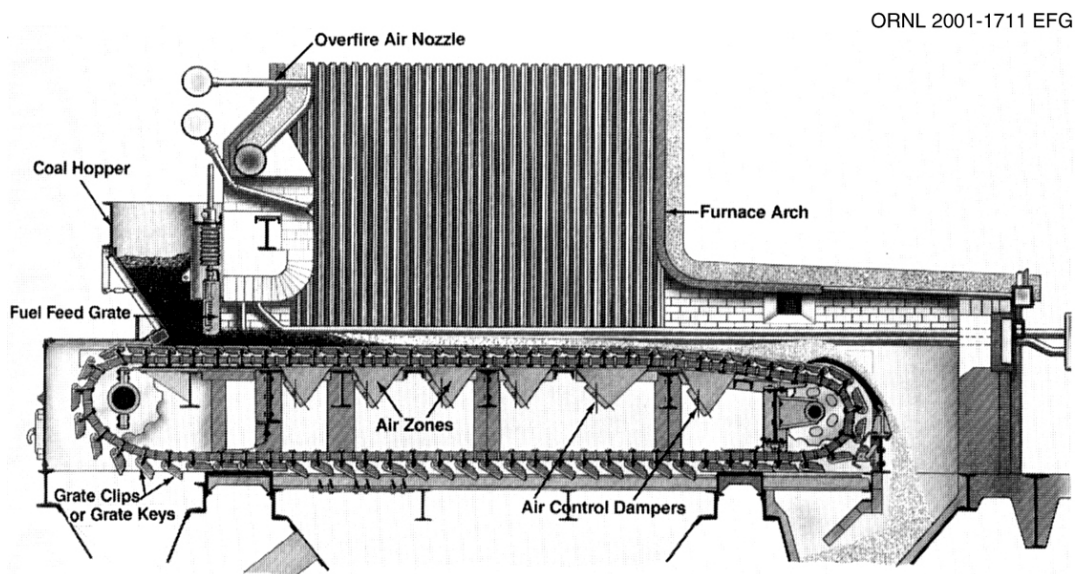

Fig. 2.20. Cross section of overfeed, traveling-grate, mass-feed stoker. *Source:* Reprinted from Ref. 11.

and (3) an overfeed water-cooled, vibrating-grate, spreader stoker are shown in Figs. 2.21–2.23, respectively. Spreader stokers with stationary water-cooled grates are used primarily in the sugar industry to burn bagasse. Modern boilers with spreader stokers consist of

- units that distribute fuel uniformly over the grate,
- specially designed air-metering grates,
- dust collection and reinjection equipment,
- blowers for OFA,
- forced draft fans for both undergrate and OFA, and
- combustion controls to coordinate fuel and air supply with steam demand.¹²

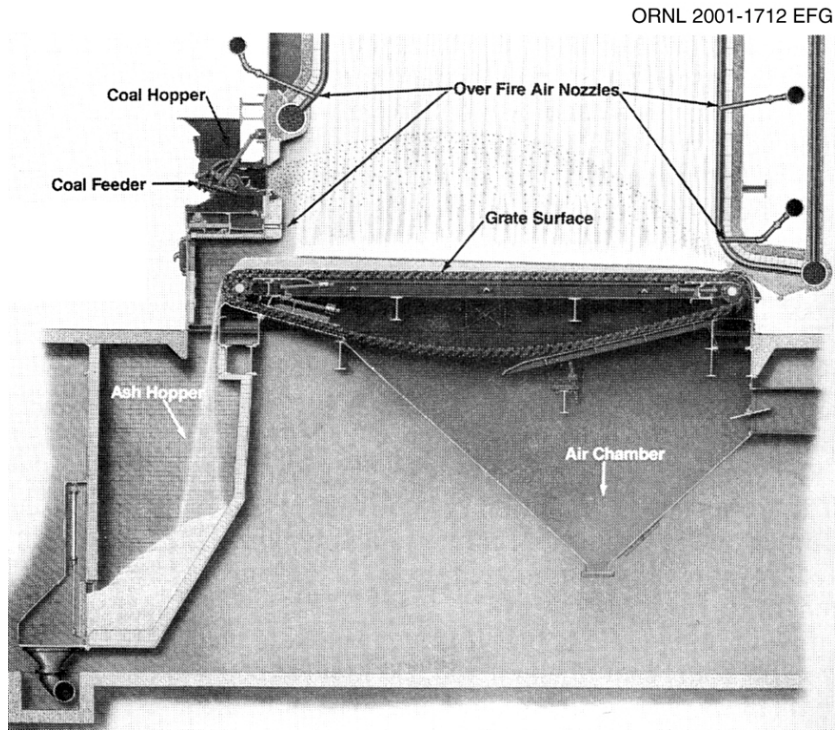

Fig. 2.21. Cross section of overfeed, traveling-grate, spreader stoker. *Source:* Reprinted from Ref. 11.

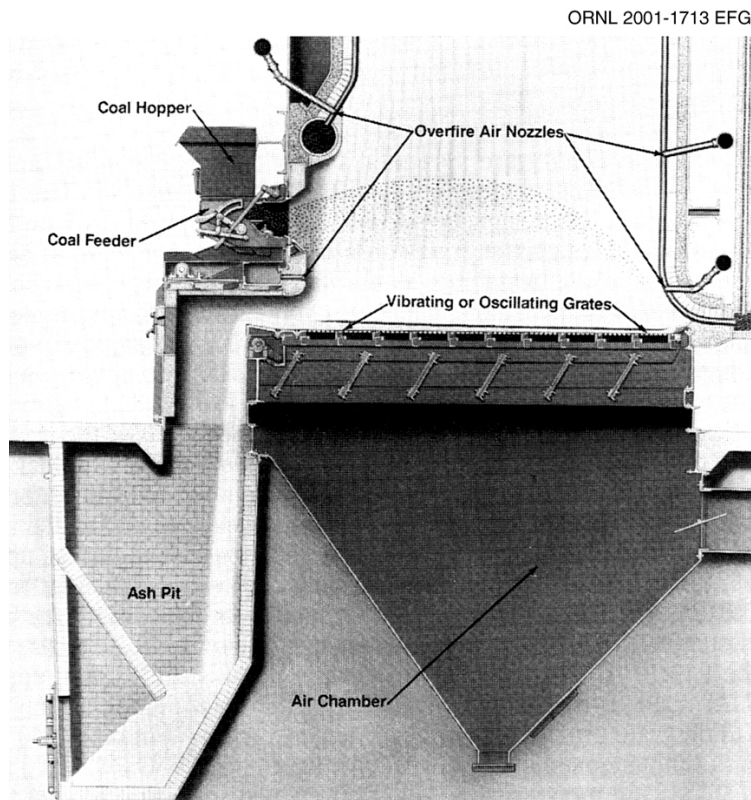

Fig. 2.22. Cross section of overfeed air-cooled, vibrating-grate, spreader stoker. *Source:* Reprinted from Ref. 11.

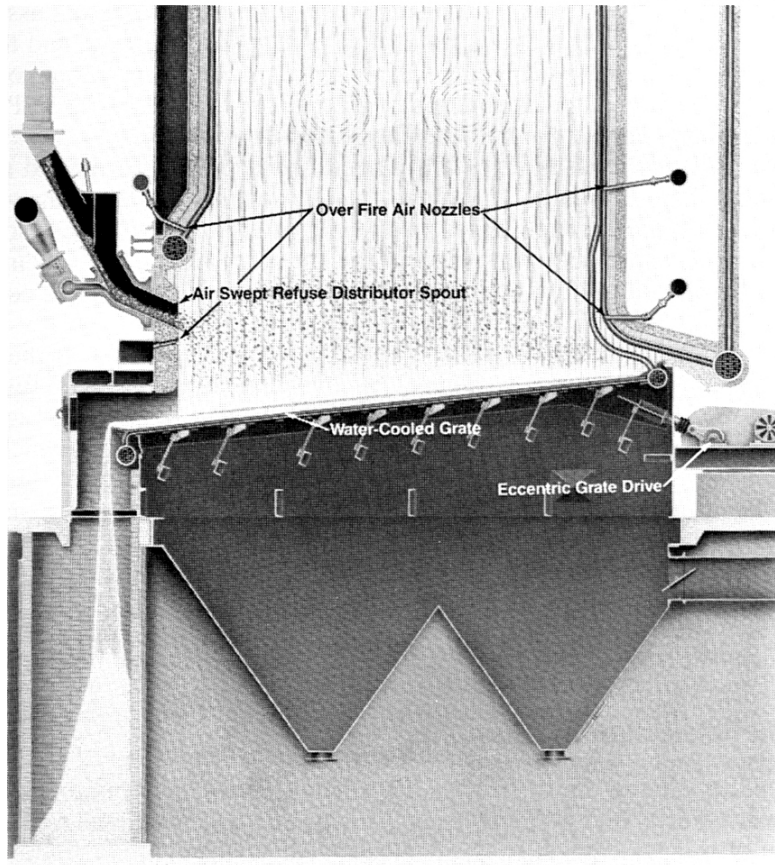

Fig. 2.23. Cross section of overfeed, water-cooled, vibrating-grate, spreader stoker. *Source:* Reprinted from Ref. 11.

2.2.2 Burners

A burner is defined as a device or group of devices for the introduction of fuel and air into a furnace at the required velocities, turbulence, and concentration to maintain ignition and combustion of fuel within the furnace. Burners for gaseous fuels are less complex than those for liquid or solid fuels because mixing of gas and combustion air is relatively simple compared to atomizing liquid fuel or dispersing solid fuel particles.

There is no formal classification system for burners, but attempts to combine desirable burner characteristics have given rise to a rich diversity in burner designs.¹³ Terminology used to identify burners that have been in existence for a long time as well as advanced burners that are based on emerging technology is listed in Table 2.3.

The ability of a burner to mix combustion air with fuel is a measure of its performance. A good burner mixes well and liberates a maximum amount of heat from the fuel. The best burners are engineered to liberate the maximum amount of heat from the fuel and limit the amount of pollutants such as CO, NO_x, and PM that are released. Burners with these capabilities are now used routinely in boilers that must comply with mandated emission limitations. Emission control techniques that are effective in reducing NO_x, CO, SO₂, and PM emissions are described in Chap. 5.

An effective way to minimize NO_x emissions is to use a low-NO_x burner (LNB). These burners employ various strategies for mixing the fuel with combustion air to reduce the formation of NO_x. Two

Table 2.3. Terminology used to identify burners

Air-atomizing oil burner
Atmospheric gas burner
Dual-fuel burner
Forced internal recirculation (FIR) burner
Low-NO _x burner (LNB)
Modulating gas power burner
Modulating pressure-atomizing oil burner
Multistage pressure-atomizing oil burner
On-off burner
Premix burner
Premix radiant burner
Premix surface burner
Premix surface-stabilized burner
PC burner
Rapid-mix burner
Rotary cup oil burner
Single-stage gas power burner
Single-stage pressure-atomizing oil burner
Staged gas power burner
Steam-atomizing oil burner
Ultra low-NO _x burner (ULNB)

techniques often used for this purpose include (1) introducing the fuel and air at different stages, and (2) recirculating flue gas with fresh combustion air. The LNBs that can be retrofitted to existing boilers have been developed and are currently being marketed. Complete systems that integrate LNBs into new and efficient boiler designs are also available.

Ultra low-NO_x burners (ULNBs) use emerging technology to reduce NO_x and CO emissions to extremely low levels. These burners are specifically designed to burn clean gaseous fuels such as natural gas that are essentially free of fuel-bound nitrogen. Discussions about ULNBs and the techniques used to minimize thermal and prompt NO_x formation are presented in Sect. 5.2.1.6.

Many vendors of conventional LNBs and ULNBs are members of the ABMA. This organization represents the manufacturers of commercial, industrial, and utility steam-generating and fuel-burning equipment, as well as suppliers to the industry. In general, technical information about the design of a particular LNB and its in-service performance can only be obtained from the manufacturer.

2.3 EMISSION RATES

Use of boilers for steam and hot water production is not limited to any particular geographic location. Consequently, atmosphere emissions resulting from fuel combustion can affect the human and natural environment over a wide area.¹⁴ In the United States, emissions of air pollutants from boilers are regulated under the CAA.¹⁵ This federal legislation was amended in 1990 to address specific concerns about ground-level ozone, the accumulation of fine particles in the atmosphere, the development of acid rain, the acidification of aquatic systems, HAPs, and visibility limitations. To effectively achieve national ambient air quality goals, EPA is authorized to establish maximum emission rates for selected pollutants from new and existing steam-generating units. This action ensures that some level of emission control is applied in all areas, irrespective of ambient air quality considerations. The degree of emissions limitation is achieved through the application of the best system of emission reduction, which has been adequately

demonstrated. Such systems are referred to as Best Available Control Technology (BACT). Conditions under which reasonably available control technology (RACT), BACT, and lowest achievable emissions rate (LAER) must be applied are discussed in Chap. 4. State and local governments are also authorized to establish emission limits that are more stringent than federal requirements.

Major emissions from combustion boilers include NO_x , SO_2 , CO, and PM. The amount of each pollutant discharged into the atmosphere is influenced by factors such as the fuel consumed and the method by which it is fired, the design features of the boiler, the way the boiler is operated, and the completeness of combustion. Achieving the required emissions reductions involves the use of precombustion, combustion, or postcombustion emission control techniques, or a combination of techniques. Emissions limitations that have been established by EPA for electric utility and ICI steam-generating units are summarized in Appendix A.

One of the main reasons for selecting and installing low-emission boilers and combustion equipment is to reduce NO_x , SO_2 , CO, and PM emissions. As discussed in Sect. 4.1, it may also be necessary in the near future to reduce HAP emissions from certain combustion boilers. Although suitable control techniques for reducing emissions vary from one unit to another, assessing the effectiveness of a particular technique requires knowledge about uncontrolled and controlled emission rates. From a regulatory viewpoint, maximum allowable emissions rates are typically specified in units of pounds per million British thermal units of heat input or as a percent of theoretical emissions.

2.3.1 Uncontrolled Emissions

Theoretical or uncontrolled emissions are defined as emissions that would result from combustion of a fuel in an uncleaned state without emission controls. The term used by EPA to quantify uncontrolled emissions is potential combustion concentration.¹⁶ For utility boilers with at least 250-MBtu/h heat input capacity, EPA has defined the following potential combustion concentrations for specific types of fuel.

For PM:

- 7.0-lb/MBtu heat input for solid fuels
- 0.17-lb/MBtu heat input for liquid fuels

For NO_x :

- 0.67-lb/MBtu heat input for gaseous fuels
- 0.72-lb/MBtu heat input for liquid fuels
- 2.30-lb/MBtu heat input for solid fuels

Currently, there are no corresponding potential combustion concentrations for NO_x and PM emissions from ICI boilers. However, EPA has developed emission factors for a variety of pollutants emitted from external combustion sources, including SO_2 and HAPs.¹⁷ External combustion sources include steam-generating plants for electricity, industrial boilers, and commercial and domestic combustion units. These emission factors are cited in numerous EPA publications and appear in various electronic databases. The process details and supporting reference materials on which these data are based have been compiled and published.¹⁷ Uncontrolled emissions from combustion sources depend on the composition of the fuel and the type of boiler. For example, for SO_2 , the emission factor representing uncontrolled emissions from a spreader stoker-fired boiler that burns bituminous coal is $38S$ lb/ton of coal, where S is the weight percent sulfur content of coal as fired.

Ranges of uncontrolled NO_x emissions are reported in ABMA and EPA publications.^{5,6,17} Data reported in these sources provide valuable insight into the level of emissions that can be expected from different types of boilers and combustion equipment. Although NO_x emission factors for many boiler and fuel combinations are listed, it is not always possible to make meaningful data comparisons. Variations in reporting methods, presentation formats, and boiler classification schemes account for some of the

uncertainty. Accurate determinations of NO_x emissions are most reliably obtained using standardized testing methods designed to minimize the influence of boiler design, method of firing, condition of combustion equipment, operational characteristics, fuel composition, and various other site-specific parameters on the test results. Test methods for determining NO_x emissions are published by ASTM and EPA.^{18–25} These methods describe analytical techniques and procedures that are suitable for specific applications.

Uncontrolled emissions of SO₂ are directly influenced by the amount of sulfur contained in the fuel. Natural gas contains essentially no sulfur, while other fuels such as coal and fuel oil often contain significant amounts of sulfur-bearing compounds. Test methods for determining the sulfur content of coal, fuel oil, and liquefied petroleum (LP) gas are referenced in applicable fuel specifications published by ASTM.^{26–28} Results of sulfur-content testing are useful in evaluating potential SO₂ emissions because any sulfur in fuel that is not removed along with the ash oxidizes to SO₂. Test methods for determining SO₂ emissions are published by EPA.^{25,29–32}

The PM emissions are a function of the noncombustible material or ash contained in the fuel. As with SO₂, test methods for determining the ash content of coal, fuel oil, and LP gas are referenced in applicable fuel specifications published by ASTM.^{26–28} Results of ash-content testing are useful in evaluating potential PM emissions because all noncombustible materials that enter the boiler and are not removed as ash become PM emissions. Test methods for determining PM emissions are published by EPA.^{25,33–35}

2.3.2 Controlled Emissions

In the United States, emissions of NO_x, SO₂, and PM from most utility and ICI boilers must be controlled by the application of one or more emission control techniques. Because there is no practical way to totally eliminate all emissions from fuel combustion, emission limits have been established to address a variety of concerns about atmospheric pollution on the human and natural environment. These limits, which are specified in units of pounds per million British thermal units or as a percent of potential combustion concentration, are based on federal and, in certain cases, more stringent state emissions standards. Discussions about emission limits in federal regulations are presented in Chap. 4. Descriptions of emission control techniques are presented in Chap. 5.

2.4 REFERENCES

1. *Analysis of the Industrial Boiler Population*, Topical Report GRI-96/0200, prepared by Energy and Environmental Analysis, Inc., for the Gas Research Institute, Chicago, Illinois, June 1996.
2. “Rules for Construction of Power Boilers,” Section I, *ASME Boiler and Pressure Vessel Code*, American Society of Mechanical Engineers, New York, 1998.
3. *Packaged Boiler Engineering Manual*, 2nd ed., American Boiler Manufacturers Association, Arlington, Virginia, 1998.
4. “Rules for Construction of Heating Boilers,” Section IV, *ASME Boiler and Pressure Vessel Code*, American Society of Mechanical Engineers, New York, 1998.
5. *Alternative Control Techniques Document—NO_x Emissions from Industrial/Commercial/Institutional (ICI) Boilers*, EPA-453/R-94-022, U.S. Environmental Protection Agency, March 1994.
6. *Guideline for Gas and Oil Emission Factors for Industrial, Commercial, and Institutional (ICI) Boilers*, American Boiler Manufacturers Association, Arlington, Virginia, 1997.
7. *Energy Efficiency Handbook*, ed. R. A. Zeitz, Council of Industrial Boiler Owners, Burke, Virginia, November 1997.
8. D. A. Wulfinghoff, *Energy Efficiency Manual*, Energy Institute Press, Wheaton, Maryland, 1999.
9. *Our Boilers and Environmental Equipment*, E101-3216C, Babcock and Wilcox Company, Barberton, Ohio, 1998.

10. *Combustion Fossil Power*, 4th ed., ed. J. G. Singer, Combustion Engineering, Inc., Windsor, Connecticut, 1991.
11. T. C. Elliott, *Standard Handbook of Powerplant Engineering*, McGraw-Hill Publishing Company, New York, 1989.
12. *Steam, Its Generation and Use*, 40th ed., ed. S. C. Stultz and J. B. Kitto, Babcock and Wilcox, Barberton, Ohio, 1992.
13. H. Soud, *Suppliers of FGD and NO_x Control Systems*, IEACR/83, IEA Coal Research, London, United Kingdom, November 1995.
14. *The Clean Air Amendments Act: Updated Strategies*, TRC Environmental Corporation, Windsor, Connecticut, and Hale and Door, Washington, D.C., 1994.
15. "Clean Air Act," U.S. Environmental Protection Agency. <http://www.epa.gov/oar/caa/contents.html>
16. "Standards of Performance for Electric Utility Steam Generating Units for Which Construction is Commenced After September 18, 1978," 40 CFR 60, Da, U.S. Environmental Protection Agency.
17. "Compilation of Air Pollutant Emission Factors," AP-42, 5th ed., Vol. I, *Stationary Point and Area Sources*, U.S. Environmental Protection Agency, January 1995. <http://www.epa.gov/ttn/chief/ap42/>
18. "Standard Test Method for Oxides of Nitrogen in Gaseous Products (Phenol-Disulfonic Acid Procedures)," ASTM D 1608, American Society for Testing and Materials, West Conshohocken, Pennsylvania, 1998.
19. "Standard Test Method for Determination of Nitrogen Oxides, Carbon Monoxide, and Oxygen Concentrations in Emissions from Natural Gas-Fired Reciprocating Engines, Combustion Turbines, Boilers, and Process Heaters Using Portable Analyzers," ASTM D 6522, American Society for Testing and Materials, West Conshohocken, Pennsylvania, 2000.
20. "Determination of Nitrogen Oxides Emissions from Stationary Sources," Method 7, 40 CFR 60, Appendix A, U.S. Environmental Protection Agency, 1999.
21. "Determination of Nitrogen Oxide Emissions from Stationary Sources—Ion Chromatographic Method," Method 7A, 40 CFR 60, Appendix A, U.S. Environmental Protection Agency, 1999.
22. "Determination of Nitrogen Oxide Emissions from Stationary Sources—Alkaline-Permanganate/Colorimetric Method," Method 7C, 40 CFR 60, Appendix A, U.S. Environmental Protection Agency, 1999.
23. "Determination of Nitrogen Oxide Emissions from Stationary Sources—Alkaline-Permanganate/Ion Chromatographic Method," Method 7D, 40 CFR 60, Appendix A, U.S. Environmental Protection Agency, 1999.
24. "Determination of Nitrogen Oxide Emissions from Stationary Sources (Instrumental Analyzer Procedure)," Method 7E, 40 CFR 60, Appendix A, U.S. Environmental Protection Agency, 1999.
25. "Determination of Sulfur Dioxide Removal Efficiency and Particulate Matter, Sulfur Dioxide, and Nitrogen Oxides Emissions Rates," Method 19, 40 CFR 60, Appendix A, U.S. Environmental Protection Agency, 1999.
26. "Standard Classification of Coal by Rank," ASTM D 388, American Society for Testing and Materials, West Conshohocken, Pennsylvania, 1999.
27. "Standard Specification for Fuel Oils," ASTM D 396, American Society for Testing and Materials, West Conshohocken, Pennsylvania, 1998.
28. "Standard Specification for Liquefied Petroleum (LP) Gases," ASTM D 1835, American Society for Testing and Materials, West Conshohocken, Pennsylvania, 1997.
29. "Determination of Sulfur Dioxide Emissions from Stationary Sources," Method 6, 40 CFR 60, Appendix A, U.S. Environmental Protection Agency, 1999.
30. "Determination of Sulfur Dioxide, Moisture, and Carbon Dioxide Emissions from Fossil Fuel Combustion Sources," Method 6A, 40 CFR 60, Appendix A, U.S. Environmental Protection Agency, 1999.

31. "Determination of Sulfur Dioxide and Carbon Dioxide Daily Average Emissions from Fossil Fuel Combustion Sources," Method 6B, 40 CFR 60, Appendix A, U.S. Environmental Protection Agency, 1999.

32. "Determination of Sulfur Dioxide Emissions from Stationary Sources (Instrumental Analyzer Procedure)," Method 6C, 40 CFR 60, Appendix A, U.S. Environmental Protection Agency, 1999.

33. "Determination of Particulate Emissions from Stationary Sources," Method 5, 40 CFR 60, Appendix A, U.S. Environmental Protection Agency, 1999.

34. "Determination of Nonsulfuric Acid Particulate Matter from Stationary Sources," Method 5B, 40 CFR 60, Appendix A, U.S. Environmental Protection Agency, 1999.

35. "Determination of Particulate Emissions from Stationary Sources (Instack Filtration Method)," Method 17, 40 CFR 60, Appendix A, U.S. Environmental Protection Agency, 1999.

3. FUELS, EMISSIONS, AND EFFICIENCY

Conversion of water to steam requires sufficient heat to cause the water to boil. Although a variety of energy sources, including nuclear energy and solar radiation, can produce the required amount of heat, combustion of a fuel in the presence of oxygen is the most common source. Combustion is a rapid chemical reaction between oxygen and a solid, liquid, or gaseous fuel. Oxygen required for this reaction is readily available in the air. As air and fuel are mixed at elevated temperatures, the oxygen reacts with carbon, hydrogen, and other elements in the fuel to produce heat. As long as fuel and air are both available, combustion will continue, and heat will be generated.

Heat produced during combustion is useful for a wide variety of applications; however, atmospheric emissions, which are also generated as by-products of the combustion process, must be controlled. Common gaseous emissions include SO₂, NO_x, water vapor, carbon dioxide (CO₂), and CO. The principle solid by-product of combustion is ash, the inorganic residue remaining after ignition of combustible materials.

Discussions that follow focus on fuels commonly fired in boilers to generate steam or hot water, atmospheric emissions associated with fuel combustion, and factors that influence how effectively the energy content of the fuel is transferred into usable heat.

3.1 FUELS

Many different solid, liquid, and gaseous fuels are fired in boilers. Sometimes, combinations of fuels are used to reduce emissions or improve boiler performance. Fuels commonly fired in boilers include fossil, biomass, and RDFs as well as other types of fuels and fuel combinations.

Coal, petroleum-based oils, and natural gas are fossil fuels commonly fired in ICI boilers. However, other forms of solid, liquid, or gaseous fuel derived from these fossil fuels are sometimes included in this category. One of these fuels, which is referred to as tire-derived fuel (TDF), consists of shredded vehicle tires.

Another boiler fuel is referred to as biomass. Biomass is renewable organic matter. Examples of biomass include fast-growing trees and plants, wood and wood waste, agricultural crops and residue, aquatic plants and algae, animal wastes, and organic municipal and industrial wastes.

RDF is a potentially valuable energy source. It consists of MSW that has been processed using size reduction and material recovery techniques to eliminate materials such as aluminum, steel, glass, plastic, and rock.

Common types of fuels fired in boilers are listed in Table 3.1 with key properties provided in Table 3.2. Additional information about some of the more common fuels is presented in the remainder of this section.

3.1.1 Coal

Coal is a brown-to-black combustible, sedimentary rocklike material composed primarily of consolidated and chemically altered plant material that grew in prehistoric forests.¹ The chemical composition of coal varies from one location to another, depending on the vegetation from which it was formed and the environmental conditions (such as temperature and pressure) to which the formation was exposed. In addition to its major chemical constituents of carbon, hydrogen, nitrogen, and oxygen, coal also contains some water and impurities of which ash, mercury, and sulfur are major concerns from an emissions viewpoint.

Table 3.1. Fuels fired in boilers to generate hot water or steam

Fuel	Description
By-product/waste	Any liquid or gaseous substance produced at chemical manufacturing plants or petroleum refineries (except natural gas, distillate oil, or residual oil) and combusted in a steam generating unit for heat recovery or for disposal. ²
Biomass	Organic matter that is used as fuel is called biomass; ³ biomass is a nonfossil fuel that includes materials such as wood, bagasse, nut hulls, rice hulls, corncobs, coffee grounds, and tobacco stems
Coal	Coal is a brown-to-black combustible sedimentary rocklike material composed principally of consolidated and chemically altered plant material that grew in prehistoric forests; ¹ it includes all solid fuel classified as anthracite, bituminous, subbituminous, or lignite coal, coal refuse, or petroleum coke. ²
Coal refuse	Waste products of coal mining, physical coal cleaning, and coal preparation operations containing coal, matrix material, clay, and other organic and inorganic materials. ⁴
Distillate oil	Fuel oils that contain 0.05 wt % nitrogen or less and comply with the specifications for fuel oil Nos. 1 and 2 as defined in ASTM D 396 (Refs. 2 and 5).
Municipal-type solid waste and RDF	Refuse, more than 50% of which is waste containing a mixture of paper, wood, yard waste, food wastes, plastics, leather, rubber, and other noncombustible materials such as metal, glass, and rock, which are usually removed prior to combustion. ²
Natural gas	A naturally occurring mixture of hydrocarbon gases found in geologic formations beneath the earth's surface, of which the principal constituent is methane, or LP gas as defined in ASTM D 1835 (Refs. 2 and 6).
Oil	Crude oil or petroleum or a liquid fuel derived from crude oil or petroleum, including distillate and residual oil. ²
Propane	Propane is a heavy gaseous fossil fuel processed from crude petroleum and natural gas. ⁶
Residual oil	Crude oil and fuel oil Nos. 1 and 2 that have nitrogen content greater than 0.05 wt %, and all fuel oil Nos. 4, 5, and 6 as defined in ASTM D 396 (Refs. 2 and 5).
Solvent-derived fuel	Any solid, liquid, or gaseous fuel derived from solid fuel for the purpose of creating useful heat and includes, but is not limited to, solvent-refined coal, liquefied coal, and gasified coal. ⁴
Very low sulfur oil	Oil that contains no more than 0.5 wt % sulfur and that, when combusted without SO ₂ emission control, has a SO ₂ emissions rate equal to or less than 215 ng/J (0.5 lb/MBtu) heat output. ²
Wood	Wood, wood residue, bark, or any derivative fuel or residue thereof, in any form, including, but not limited to, sawdust, sanderdust, wood chips, scraps, slabs, millings, shavings, and processed pellets made from wood or other forest products. ²
Wood residue	Bark, sawdust, slabs, chips, shavings, mill trim, and other wood products derived from wood processing and forest management operations. ⁷

Table 3.2. Key properties for selected fuels

Fuel	High heating value	Carbon (%)	Hydrogen (%)	Ultimate CO₂ (%)
Anthracite coal	12,680 Btu/lb	80.6	2.4	19.9
Bagasse	8,200 Btu/lb	45.0	6.4	20.3
Bark				
15% moisture	8,500 Btu/lb	52.0	5.5	20.0
30% moisture	8,500 Btu/lb	52.0	5.5	20.0
45% moisture	8,500 Btu/lb	52.0	5.5	20.0
60% moisture	8,500 Btu/lb	52.0	5.5	20.0
Bituminous coal	14,030 Btu/lb	80.1	5.0	18.5
Distillate No. 1	19,423 Btu/lb	86.6	13.3	15.4
	131,890 Btu/gal			
Fuel oil No. 2	18,993 Btu/lb	87.3	12.5	15.7
	137,080 Btu/gal			
Fuel oil No. 5	18,909 Btu/lb	88.7	10.7	16.3
	149,960 Btu/gal			
Fuel oil No. 6	18,126 Btu/lb	88.5	9.3	16.7
	153,120 Btu/gal			
Kerosene	19,942 Btu/lb	86.5	13.2	15.1
	137,000 Btu/gal			
Natural gas	21,830 Btu/lb	69.4	22.5	11.7
Propane	21,573 Btu/lb	81.6	18.4	13.8
Wood				
10% moisture	8,800 Btu/lb	50.0	6.5	20.0
20% moisture	8,800 Btu/lb	50.0	6.5	20.0
30% moisture	8,800 Btu/lb	50.0	6.5	20.0
40% moisture	8,800 Btu/lb	50.0	6.5	20.0

Source: Ref. 8.

A number of physical and chemical properties influence the coal selection process. These properties are determined by laboratory analysis of representative coal samples using test methods established by the American Society for Testing and Materials (ASTM). Important coal properties include⁹

- moisture;
- proximate analysis (fixed carbon, volatile matter, ash);
- ultimate analysis (carbon, hydrogen, nitrogen, oxygen, sulfur, and chlorine);
- gross caloric value (as received and on a dry basis);
- mineral matter in coal (ash, major and minor elements, fusibility of ash, trace elements, mercury, fluorine, arsenic, selenium, and sulfur in ash);
- petrographic analysis;
- grindability;
- free-swelling index;
- CO₂;
- forms of sulfur (pyritic, sulfate, organic); and
- ash abrasiveness.

The chemical composition of coal is also determined in a laboratory by chemical analysis. Results of these analyses are used for heat-balance calculations and the determination of theoretical air requirements.

Moisture represents an impurity that adds to the weight of coal but not to its heating value. The moisture may be a constituent of the coal, or it may be present on the surface of the coal because of precipitation or coal cleaning operations. Moisture content, which is expressed as a percentage, is defined as the difference between the weight of a coal sample before and after the sample is maintained in an oven at 220°F for 1 h. When moisture in coal is heated, some of the heat generated by the combustion process must be used to convert the water to steam. Normally it is more economical to burn coal with a low moisture content; but when coal is burned on certain grates, there are conditions that make it advantageous to have small amounts of moisture present. Moisture tends to accelerate the combustion process, keep the fuel bed even, and promote uniform burning. Coals having 7 to 12% moisture content are recommended for use in chain-grate and traveling-grate stokers.¹⁰ The addition of moisture to coal to enhance the combustion process is referred to as tempering.

When coal is heated, the gaseous substance that is driven off is “volatile matter.” This matter, which consists mostly of hydrocarbon gases, burns in the combustion space above the fuel. Coal with a relatively high percentage of volatile matter is termed “soft;” whereas coal with a relatively low percentage of volatile matter is termed “hard.” When soft coal is burned in a pulverized form, the volatile matter is distilled off and burns as a gas. This makes soft coal relatively easy to burn because ignition is maintained and complete combustion is achieved with minimum flame travel. Combustion of pulverized hard coal, which has less volatile matter, is more difficult to accomplish. To improve combustion, it may be necessary to pulverize hard coals with low volatility to a smaller particle size compared to soft coals or use more intense firing methods.

Inert solid matter that remains after combustion is called ash. It includes mineral or inorganic material, such as silica, that was introduced as the coal was being formed. Clay, silt, sand, shale, slate, and pyrite particles are other ash-forming materials commonly found in the stratified layers of coal seams. Because ash is inert, coal with a high ash content may have a lower heating value. Although ash is usually considered a waste product that must be transported for disposal, it can have value as a construction material. For example, fly ash has been used as a base for roadways, structural fill, waste stabilization, soil modification, and backfill. Fly ash that is produced in some coal-fired boilers may be suitable for use as a mineral admixture in concrete if it satisfies chemical and physical specification requirements established by the ASTM.¹¹ Ash from certain coal combustion processes is also used in the manufacture of concrete masonry units.

Sulfur is an impurity in coal that occurs in three forms: (1) organic sulfur, which is part of the plant’s molecular structure; (2) pyritic sulfur, which occurs as iron sulfide and is better known as the mineral pyrite; and (3) sulfate sulfur, which is primarily from iron sulfate.¹⁰ The highest sulfur source is from sulfates found in some freshwater and seawater. Bituminous coals that are found in the interior of the United States where oceans once covered the region are high in sulfur. When selecting coal and the equipment used for its combustion, consideration must be given to the sulfur content of the coal. The corrosive effects of sulfur can influence material selection, and the amount of SO₂ that is discharged into the atmosphere can dictate the need for pollution control equipment. In particularly corrosive environments such as those where low-temperature flue gas is present, corrosion-resistant materials are sometimes specified to minimize or avoid corrosion damage. For new units, installation of SO₂ scrubbing systems that remove more than 90% of the SO₂ in the flue gas may also be required, depending on the sulfur content of the coal. Switching from high- to low-sulfur coal can be an effective method for existing units to deal with sulfur-related issues.

A classification system for distinguishing one coal from another has been established by the ASTM. This system covers anthracitic, bituminous, subbituminous, and lignitic coals.¹² Classification is according to fixed carbon and gross caloric value expressed in British thermal units per pound (Btu/lb). Higher-ranking coals with at least 69% fixed carbon are classified on the dry basis. Lower ranking coals with a caloric value up to 14,000 Btu/lb are classified on the moist basis. The ASTM has established standard test methods for use in classifying coal.^{13–17} The four classes of coals and their associated groups are identified and summarized in the following paragraphs.

3.1.1.1 Lignite

Lignite is the lowest ranking coal with a heating value of 8,300 Btu/lb or less and a moisture content as high as 35%.¹⁰ Depending on the caloric value, lignitic coals are subdivided into the two classes shown in Table 3.3.

Lignitic coals have a high content of volatile matter, which makes them relatively easy to ignite, especially when the combustion air is preheated. Because lignite has a relatively low sulfur content, it emits low amounts of SO₂.

Table 3.3. Lignite coals

Class/group	Gross caloric value limits (Btu/lb) (moist, mineral-matter-free basis)	
	Equal or greater than	Less than
Lignite A (abbreviated ligA)	6,300	8,300
Lignite B (abbreviated ligB)	No limit	6,300

Source: Ref. 12.

3.1.1.2 Subbituminous

Subbituminous coals, which have a heating value between 8,300 and 11,500 Btu/lb, have a higher heating value than lignitic coals. They also have less ash and burn cleaner than lignitic coals, but the moisture content is relatively high, usually between 15 and 30%. Subbituminous coals are subdivided into three classes based on the caloric values listed in Table 3.4.

The sulfur content of most subbituminous coal is low, generally less than 1%. Because the sulfur content is low, many power plants have changed to subbituminous coal to limit SO₂ emissions.¹⁰ Low-sulfur coals, which are mined in Montana and Wyoming, are relatively low in cost.

Combustion of subbituminous coal results in reduced NO_x emissions, but generally exhibits high fouling and slagging ash characteristics. Burning subbituminous coal in a boiler that was designed for a different class of coal may require changes in the boiler design or operation to optimize performance.

Table 3.4. Subbituminous coals

Class/group	Gross caloric value limits (Btu/lb) (moist, mineral-matter-free basis)	
	Equal or greater than	Less than
Subbituminous A (abbreviated subA)	10,500	11,500
Subbituminous B (abbreviated subB)	9,500	10,500
Subbituminous C (abbreviated subC)	8,300	9,500

Source: Ref. 12.

3.1.1.3 Bituminous

Bituminous coals are used routinely by electric utilities and in some industrial applications to fire steam-generating boilers even though their sulfur content can be relatively high. Compared to lignitic and subbituminous coals, the heating value of bituminous coals range between 10,500 and 14,000 Btu/lb. This higher heating value and its relatively high volatile matter enable bituminous coals to burn easily when fired as PC. Bituminous coals are subdivided into the following groups in Table 3.5 based on fixed carbon, volatile matter, or gross caloric limits.

Table 3.5. Bituminous coals

Class/group	Fixed carbon limits (%) (dry, mineral-matter-free basis)		Volatile matter limits (%) (dry, mineral-matter-free basis)		Gross caloric value limits (Btu/lb) (moist, mineral-matter-free basis)	
	Equal or greater than	Less than	Greater than	Equal or less than	Equal or greater than	Less than
Low-volatile bituminous coal (abbreviated lvb)	78	86	14	22	No limit	No limit
Medium-volatile bituminous coal (abbreviated mvb)	69	78	22	31	No limit	No limit
High-volatile A bituminous coal (abbreviated hvAb)	No limit	69	31	No limit	14,000	No limit
High-volatile B bituminous coal (abbreviated hvBb)	No limit	No limit	No limit	No limit	13,000	14,000
High-volatile C bituminous coal (abbreviated hvCb)	No limit	No limit	No limit	No limit	11,500 (commonly agglomerating) 10,500 (agglomerating)	13,000 (commonly agglomerating) 11,500 (agglomerating)

Source: Ref. 12.

3.1.1.4 Anthracite

As a fuel, anthracitic coals are the highest ranking with fixed carbon contents ranging from 86 to 98%. In addition to their high carbon content, they have a moisture content that is only about 3% and a heating value that can be as high as 15,000 Btu/lb. Anthracitic coals are characterized as slow-burning fuels that are low in sulfur and volatile matter. These coals are used mostly to make coke for metallurgical processes.¹⁰ Anthracitic coals are subdivided into the following groups in Table 3.6 based on their fixed carbon and volatile matter content.

Table 3.6. Anthracitic coals

Class/group	Fixed carbon limits (%) (dry, mineral-matter-free basis)		Volatile matter limits (%) (dry, mineral-matter-free basis)	
	Equal or greater than	Less than	Greater than	Equal or less than
	Meta-anthracite (abbreviated ma)	98	No limit	No limit
Anthracite (abbreviated an)	92	98	2	8
Semianthracite (abbreviated sa)	86	92	8	14

Source: Ref. 12.

If the quality of coal from a particular location does not meet the applicable fuel specification, it can be processed in different ways to upgrade its quality. Operations such as washing, drying, sizing, and blending of coals from different sources are techniques that may be used to produce acceptable coal, but other methods that involve separation of foreign materials such as slate and pyrites from the coal may be necessary. Although one or more of these methods may produce coal with the desired quality, special equipment may be required to perform the operations.

3.1.2 Fuel Oil

Petroleum is a naturally occurring black liquid found floating on subterranean lakes of saltwater and located beneath dome-shaped nonporous rock formations. These deposits consist of natural gas, crude oil, and saltwater separated into layers by virtue of their difference in specific gravity. When a well is drilled through the rock formation, natural gas flows to the surface where it is either burned or transported by pipeline to a processing facility. Depending on the pressure, the crude oil either flows to the surface or is removed by pumping. Once above ground, the crude oil is transported by pipeline, truck, rail, barge, or ship to a refinery. At the refinery, the crude oil is processed into any number of petroleum-based products, including fuel oils.

Fuel oils burned in boilers include the heavier petroleum products that are less volatile than gasoline. They are divided into two classes, distillate and residual. Distillate oils are lighter than residual oils with a consistency between kerosene and lubricating oil. They have a low viscosity and are typically sediment- and ash-free. Because distillate oils are relatively clean fuels, they are used primarily for home heating and industrial applications where low ash and low sulfur are important. Smaller amounts of distillate oil are used in steam generation applications as a startup or supplemental fuel for certain solid-fuel combustion processes. Residual oils are products that remain after the more volatile hydrocarbons have been extracted. Residual oils, which are highly viscous, are usually free from moisture and sediment after processing. Some of the heavier residual oils must be heated to make the fuel easier to handle and burn. Sometimes, distillate and residual oils are blended to create a mixture with proportions that meet a desired fuel specification. As a liquid, fuel oils are relatively easy to handle and burn. In most oil burners,

the oil is atomized with air, steam, or pressure to enhance combustion. The characteristics of atomized oil approximate those of natural gas.¹⁰

The heating value of fuel oil is derived primarily from its two major constituents, hydrogen and carbon. Most fuel oils have a hydrogen content that ranges between 10 and 14%, and a carbon content that ranges between 86 and 90%.¹⁸ Heating values for fuel oils are expressed in units of either British thermal unit per pound (Btu/lb) or per gallon (Btu/gal) at 60°F. Complete combustion of 1 lb of carbon yields a gross heat of 14,500 Btu.¹⁹ Hydrogen has a very high heating value compared to carbon; but it is a very lightweight gas, so the heating value of 1 ft³ of hydrogen is low compared to other gaseous fuels. Heating values for commercial fuel oils vary from approximately 17,500 to nearly 20,000 Btu/lb.¹⁸ Other constituents in fuel oils include nitrogen, sulfur, ash, and impurities such as moisture and sediment. Compared to coal, the nitrogen and ash contents of most fuel oils are very low. Residual oils tend to have higher nitrogen contents than distillate oils.

A standard specification for five grades of fuel oil intended for use in different types of fuel-oil-burning equipment under various climatic and operating conditions has been developed by the ASTM.⁵ Requirements in this specification cover both distillate and residual oils. The various grade numbers into which fuel oils are subdivided are listed in Table 3.7. Fuel oil Grade No. 2 is considered a premium steam-generating fuel because its cleanliness and ease of handling are often used to justify its relatively high cost. The cost of Grade No. 6 fuel oil is relatively low, but heating of the fuel is required to facilitate handling and burning.

Sulfur found in fuel oil is very undesirable. Its products of combustion are very acidic and can cause corrosion in economizers, air heaters, induced draft fans, flue gas ducts, and stacks. The sulfur content of fuel oil can vary from a low of 0.01% for Grade No. 1 to as high as 3.5% for Grade No. 6 (Ref. 18). During combustion, some of the sulfur accumulates in the ash, but most is discharged with the flue gas into the atmosphere. If uncontrolled SO₂ emissions exceed established limits, it may be necessary to switch to a lower sulfur oil or install SO₂ scrubbers to meet applicable emissions standards.

3.1.3 Natural Gas

Natural gas is a colorless hydrocarbon fuel consisting primarily of methane (CH₄) and ethane (C₂H₆), its two principle combustible components. It is typically found under the earth's surface in porous rock and shale formations or above crude oil deposits located beneath dome-shaped nonporous rock formations. When a well is drilled through the formation, natural gas, which is under pressure, flows to the surface where it is either burned or transported by pipeline to a processing facility. This characteristic makes natural gas a very desirable boiler fuel because it can be piped directly into the boiler. In addition to its ease of distribution, use of natural-gas-fired boilers requires a relatively small boiler space, and the overall plant design is typically compact and simple. With a heating value of about 1,000 Btu/ft³ under standard conditions of 60°F at atmospheric pressure and low excess-air requirements that contribute to high efficiency, natural gas is perhaps very close to an ideal fuel.

When natural gas at the well head contains sulfur-bearing alcohols and phenols (mercaptans) and a high percentage of hydrogen sulfide, it is referred to as sour gas. By removing the objectionable constituents, sour gas can be converted to sweet gas. Sweet gas is required for distribution in pipelines to avoid corrosion problems caused by exposure to hydrogen sulfide. Removal of sulfur from the gas also eliminates the possibility of SO₂ emissions during combustion.

From an emissions viewpoint, natural gas is an excellent fuel choice. Although natural gas from some sources contains noncombustible gases such as nitrogen and carbon dioxide, it is practically free from solid residue. Because it is free of ash and mixes easily with air, combustion is usually complete without objectionable smoke or soot. The only significant problem with using natural gas as a fuel for boilers is related to its chemical composition. Natural gas has a relatively high hydrogen content (greater than 20% by weight) compared to other fossil fuels such as oil and coal. During combustion, the

Table 3.7. Fuel oil grades established by ASTM

Fuel oil	Description
Grade No. 1	Distillate fuel for use in domestic and small industrial burners. This grade is particularly adapted to vaporizing burners in which the oil is converted to a vapor by contact with a heated surface or by radiation or where storage conditions require low-pour-point fuel. High volatility is necessary to ensure that evaporation proceeds with a minimum of residue. The maximum allowable sulfur content is 0.5% by mass. The maximum allowable ash content is not specified.
Grade No. 2	Distillate fuel that is heavier than Grade No. 1. It is intended for use in atomizing burners that spray the oil into a combustion chamber where the tiny droplets burn while in suspension. This grade of fuel oil is used in most domestic burners and in many medium-capacity commercial-industrial burners where its ease of handling and ready availability sometimes justify its higher cost over residual fuels. The maximum allowable sulfur content is 0.5% by mass. The maximum allowable ash content is not specified.
Grade No. 4 (light)	Heavy distillate fuel or distillate/residual fuel blend used in commercial/industrial burners equipped for this viscosity range. This grade of fuel oil is intended for use both in pressure-atomizing commercial-industrial burners not requiring higher cost distillates and in burners equipped to atomize oils of higher viscosity. Its permissible viscosity range allows it to be pumped and atomized at relatively low storage temperatures. The maximum allowable sulfur content is not specified. The maximum allowable ash content is 0.05% by mass.
Grade No. 4	Heavy distillate fuel or distillate/residual fuel blend used in commercial/industrial burners equipped for this viscosity range. This grade of fuel oil is intended for use in burners equipped with devices that atomize oils of higher viscosity than domestic burners can handle. Its permissible viscosity range allows it to be pumped and atomized at relatively low storage temperatures. Thus, in all but extremely cold weather it requires no preheating for handling. The maximum allowable sulfur content is not specified. The maximum allowable ash content is 0.10% by mass.
Grade No. 5 (light)	Residual fuel oil of intermediate viscosity intended for use in industrial burners capable of handling fuel more viscous than Grade No. 4 without preheating. Preheating may be necessary in some equipment for proper atomization and in colder climates for handling. The maximum allowable sulfur content is not specified. The maximum allowable ash content is 0.15% by mass.
Grade No. 5 (heavy)	Residual fuel oil used in industrial burners with an increased viscosity and boiling range compared to Grade No. 5 (light). Preheating may be necessary in some types of equipment for proper atomization and in colder climates for handling. The maximum allowable sulfur content is not specified. The maximum allowable ash content is 0.15% by mass.
Grade No. 6	Residual fuel oil used in industrial burners with an increased viscosity and boiling range compared to Grade No. 5 (heavy). Preheating is required for handling and proper atomization. Extra equipment and maintenance required to handle this fuel usually preclude its use in smaller installations where cleanliness and ease of handling are important. The maximum allowable sulfur content and the maximum allowable ash content are not specified.

Source: Ref. 5.

hydrogen in natural gas combines with oxygen to form water vapor. As discussed in Sect. 3.3, formation of relatively large quantities of water vapor translates to lower boiler efficiency.

Like natural gas, other types of gases can also be used as fuels for boilers, but their processing costs generally make them too expensive for most large-scale applications. By-product substitutes for natural gas include producer gas, coke-oven gas, water gas, and blast-furnace gas derived from coal, refinery gas and oil gas derived from oil, and liquefied petroleum (LP) gas, including propane and butane, derived from either natural gas or oil.⁶

3.1.4 Biomass

Biomass is a nonfossil fuel suitable for steam generation in boilers. It is derived from plant material including wood, bagasse, nut hulls, rice hulls, corncobs, coffee grounds, and tobacco stems. Use of these by-product materials as fuel can be cost-effective especially when it solves a waste disposal problem.

Wood is a complex vegetable tissue composed principally of cellulose. Most wood burned in boilers is a by-product from manufacturing operations such as sawmills, paper mills, and factories that manufacture wood products. By-products from these operations may take the form of bark, sawdust, sanderdust, chips, scraps, slabs, millings, shavings, and processed pellets made from wood or other forest products. Care must be used when burning fine wood dust because under certain conditions it can ignite quickly. Depending on the species and moisture content, the heating value of wood varies over a wide range.²⁰ Although certain types of wood are more suitable for steam production, sufficient supplies of the fuel may not always be available. In these situations, it may be necessary to burn supplementary fuels along with the wood to meet the total steam demand.

Bagasse is a by-product fuel produced when the juice is removed from cane in a sugar mill. Although its heating value can be as high as 8,000 to 9,000 Btu/lb, combustion of bagasse is only feasible in certain parts of the United States where sugar cane is processed. When bagasse is burned, it is usually supplemented with auxiliary fuels.

Other biomass fuels include

- nut hulls with a heating value of about 7,700 Btu/lb,
- rice hulls with a heating value between 5,200 and 6,500 Btu/lb,
- corncobs with a heating value between 7,500 to 8,300 Btu/lb, and
- coffee grounds from instant coffee production with a heating value between 4,900 to 6,500 Btu/lb (Ref. 20).

3.1.5 Refuse-Derived Fuel

Residential, commercial, and industrial solid waste that is transported to a landfill for disposal can be burned as a fuel in waste-to-energy boilers. MSW that contains mixtures of paper, wood, yard wastes, food wastes, plastics, leather, and rubber can have characteristics similar to wood. Use of MSW as a fuel can be accomplished by burning the as-received material, called mass burning; but processing is often required before it can be burned effectively. When MSW is processed using size-reduction and material-recovery techniques designed to shred the waste and remove noncombustible materials, it is called RDF.¹⁸ The highly variable nature of MSW presents challenges in designing a combustion system that can accommodate this high-ash, low-sulfur fuel.

3.1.6 Other Fuels

Heavy residuals from petroleum-cracking processes yield a solid residue that is suitable for use as a fuel for boilers.¹⁸ Solid fuels derived from oil include delayed coke, fluid coke, and petroleum pitch. Some cokes produced by the delayed coking process are easy to pulverize and burn in boilers. Fluid

cokes can also be pulverized and burned in boilers or burned in a cyclone furnace or a fluidized bed, but all three of these methods may require supplemental fuel to aid start-up. Petroleum pitch yields fuel with varying characteristics. Low-melting-point pitches can be heated and burned like heavy oil. Those with higher melting points must be pulverized or crushed and then burned.

Coal tar pitch is the residue resulting from the distillation and refining of coal tar. Although it can be used as a boiler fuel, it is somewhat difficult to handle. At ambient temperature, it is a solid that can be pulverized before it is delivered to the boiler. At about 300°F, it becomes a liquid and can be burned like oil. Because of its low ash content, use of coal tar pitch is sometimes preferable to coal.²⁰

Pulp mill sludge can be used as a fuel for boilers, but it must be dried before it can be effectively burned. This fuel typically has an ash content of approximately 10%. Sludges from deinking processes are less suitable because they have less heating value and significantly more ash. Unless sludge from the deinking process is dried before it enters the boiler, the combination of high moisture content and low heating value make it difficult to burn. Burning sludge with a high-moisture content in stoker-fired boilers presents some significant problems because removal of the moisture results in a lower combustion chamber temperature. For this reason, sludge is generally burned in stoker-fired boilers in combination with another fuel such as bark.¹⁰

3.1.7 Mixed Fuels

Environmental concerns about SO₂ and PM emissions from combustion of bituminous coals have led to the development of coal cleaning techniques known as beneficiation.¹⁸ These techniques involve removal of sulfur and mineral matter from coal prior to combustion. To achieve the cleaning level needed to meet sulfur standards, the form of the solid coal must first be altered. Most advanced cleaning processes use water as the separation medium and involve grinding the coal to fine particle size. Grinding allows pyritic sulfur and other minerals that are dispersed throughout the coal to be more easily separated from the coal. After these materials are removed, the fine, clean coal product must be dried, pelletized, or reconstituted into a coal-water slurry, which can be handled like oil prior to combustion in a boiler.

Coal-water slurries have potential as fuel oil substitutes in some combustion applications. Typical bituminous coal slurries contain approximately 70% PC, 29% water and 1% chemical additives. Slurries prepared from coals, which have been deep cleaned, can contain coal with finer particle sizes and a lower solids content (50 to 60%). Although coal-water slurries are produced from fine PC and are handled and fired like No. 6 fuel oil, they burn somewhat differently. Burners suitable for coal-water slurry combustion are often specially designed to accommodate the unique properties of the slurry. Viscosity and flow characteristics can affect the way the fuel is atomized and can increase wear and deterioration of piping and burner components.

Oil-water slurries can be used as fuel with combustion performance similar to residual oils. These liquid-fuel emulsions are composed of micron-size oil droplets dispersed in water.¹⁸ Although the heating value, ash content, and viscosity of oil-water slurries are similar to residual oil, they have a relatively high sulfur content.

3.2 EMISSIONS

Federal, state, and local government agencies regulate air pollutants emitted from steam generating units in accordance with the CAA.²¹ This legislation establishes primary and secondary National Ambient Air Quality Standards (NAAQS) for six criteria pollutants, including ground-level ozone, NO_x, SO₂, CO, PM, and lead.²² These standards address concerns about ground-level ozone, the accumulation of fine particles in the atmosphere, and acid rain. Emissions of criteria pollutants from steam generating units include NO_x, SO₂, CO, and PM.

The CAA, as amended in 1990, also requires EPA to establish standards for reducing toxic air pollutant emissions. The 1990 Act includes a list of 189 HAPs selected by Congress on the basis of their

potential health and environmental hazards, and it authorizes EPA to establish regulations for each of these pollutants. Toxic air pollutants, also known as HAPs, are those pollutants that are known or suspected to cause cancer or other serious health effects, such as reproductive effects or birth defects or adverse environmental effects. To regulate HAPs, EPA has identified categories of sources that release these listed chemicals. One of these categories includes ICI boilers. Toxic air pollutants that are emitted during the combustion of certain fuels include metals such as cadmium, mercury, chromium, and lead compounds.

3.2.1 Nitrogen Oxides

During the combustion process, NO_x is one of the primary pollutants emitted into the atmosphere. In this context, NO_x refers to the cumulative emissions of nitric oxide (NO), nitrogen dioxide (NO₂), and trace quantities of other species as shown in Table 3.8.²³ Although mobile sources are the largest contributor to NO_x formation in the United States, combustion of any fossil fuel generates some level of NO_x because of high temperatures and the availability of oxygen and nitrogen from both the air and fuel. The NO_x emissions from fired processes are typically 90 to 95% NO with the balance being predominantly NO₂. Once the flue gas leaves the stack, the bulk of the emitted NO is eventually oxidized in the atmosphere to NO₂.

Dispersed in the atmosphere, NO₂ reacts to form secondary pollutants, including ground-level ozone and acid rain. Chemical reactions between volatile organic compounds (VOCs) (hydrocarbon radicals) and NO_x create ground-level ozone, which is not to be confused with ozone found in the upper atmosphere. When these materials react in the presence of sunlight, they form ground-level ozone, a major ingredient of smog. When NO_x reacts with water vapor and air, it forms very dilute nitric acid. Control of acid rain has focused primarily on reducing SO₂ emissions because NO_x is estimated to contribute less than one-third of the acid rain generated.

There are two common mechanisms of NO_x formation, thermal NO_x and fuel NO_x (Ref. 18). Thermal NO_x refers to the NO_x that formed through high-temperature oxidation of nitrogen found in the combustion air. Fuel NO_x involves the conversion of fuel-bound nitrogen found in nitrogen-bearing fuels, such as coal and oil, to NO_x during combustion. A third type of NO_x that forms under certain conditions is known as prompt NO_x.

Table 3.8. Nitrogen oxides

Formula	Name	Properties
N ₂ O	Nitrous oxide	Colorless gas, water soluble
NO	Nitric oxide	Colorless gas, slightly water soluble
N ₂ O ₂	Dinitrogen dioxide	Colorless gas, slightly water soluble
N ₂ O ₃	Dinitrogen trioxide	Black solid, water soluble, decomposes in water
NO ₂	Nitrogen dioxide	Red-brown gas, very water soluble, decomposes in water
N ₂ O ₄	Dinitrogen tetroxide	Red-brown gas, very water soluble, decomposes in water
N ₂ O ₅	Dinitrogen pentoxide	White solid, very water soluble, decomposes in water

Source: Ref. 23.

3.2.1.1 Thermal NO_x

The formation rate of thermal NO_x is a strong function of temperature as well as the residence time at temperature. Significant levels of NO_x are usually formed above 2,600°F. Above this temperature the rate of thermal NO_x increases exponentially. At these high temperatures, molecular nitrogen (N₂) and oxygen (O₂) in the combustion air can dissociate into their atomic states and participate in a series of

reactions. One product of these reactions is NO. At temperatures below 1,400°F, NO is either generated in much lower concentrations or not at all.^{23,24}

Thermal NO_x formation is typically controlled by reducing the peak and average flame temperatures. Although this approach is contrary to traditional methods of assuring complete combustion (i.e., high temperatures, long residence time, and high turbulence or mixing), some compromise between effective combustion and controlled NO_x formation is needed. This can be accomplished through a number of combustion system changes:

- Use of controlled mixing burners to reduce the turbulence in the near burner region of the flame and to slow the combustion process. This typically reduces the flame temperature by removing additional energy from the flame before the highest temperature is reached.
- Use of staged combustion where part of the combustion air is initially introduced to burn some of the fuel. The remaining air is added separately to complete the combustion process. This lowers the peak flame temperature by reducing the oxygen concentration. Combustion at very low excess air levels is an effective way to control NO_x formation.
- Use of staged combustion where a portion of the total fuel is added with an excessive amount of combustion air. The remaining fuel is then added at a later stage in the combustion process. Combustion at very high excess air levels is an effective way to control NO_x formation.
- Use of a technique known as flue gas recirculation (FGR) in which some of the flue gas is mixed with the combustion air at the burner. This increases the gas weight that must be heated by the chemical energy in the fuel, thereby reducing the flame temperature.
- Use of multiflame burners and lean premix combustion that breaks the total heat input into smaller flames with effective mixing. This lowers peak flame temperatures and allows the heat to be removed rapidly by placing the flame in close proximity to the heating surface.
- Use of a premixed blend of air and gaseous fuel with the option of adding flue gas to the mixture will cause combustion to occur at a relatively low temperature, thus reducing thermal NO_x formation. Burners that premix gaseous fuel and air to control thermal NO_x formation are described in Sect. 5.2.1.6.
- Use of combinations of these techniques.

These approaches have been used effectively with gas, oil, or coal firing to reduce NO_x formation. For fuels that do not contain significant amounts of chemically bound nitrogen, such as natural gas, thermal NO_x is the primary overall contributor to NO_x emissions. In these cases, the approaches previously described are particularly effective in NO_x emission control.

3.2.1.2 Fuel NO_x

The major source of NO_x emissions from nitrogen-bearing fuels such as coal and oil is the conversion of fuel-bound nitrogen to NO during combustion. Laboratory studies indicate that fuel NO_x contributes approximately 50% of the total uncontrolled emissions when firing residual oil and more than 80% when firing coal.¹⁸ Nitrogen found in fuels such as coal and residual oils is typically bound to the fuel as part of organic compounds. During combustion, the nitrogen is released as a free radical to ultimately form NO or N₂. Although it is a major factor in NO_x emissions, only 20 to 30% of the fuel-bound nitrogen is converted to NO.

Conversion of fuel-bound nitrogen to NO is strongly dependent on the fuel-air proportions, but it is relatively independent of variations in combustion zone temperature. Therefore, reducing oxygen availability during the initial stages of combustion can control this conversion. Techniques such as controlled fuel-air mixing and staged combustion can provide a significant reduction in NO_x emissions.

Removing nitrogen from fuel before it is burned is not easily achieved, but switching from a high-nitrogen-content fuel to a lower nitrogen-content fuel may be effective in reducing NO_x emissions. In

general, coal combustion produces the highest NO_x emissions with oil combustion generating less and gas combustion producing the least. For oil, a reduction in fuel nitrogen results in a decrease in NO_x formation; but for coal, reducing fuel nitrogen may not provide a corresponding reduction.

3.2.1.3 Prompt NO_x

A portion of the NO_x that is formed by oxidation of the fuel-bound nitrogen under fuel-rich conditions is referred to as prompt NO_x (Ref. 18). The name is derived from its formation very early during the combustion process. Prompt NO_x occurs through the formation of intermediate hydrogen cyanide (HCN) species and the reaction between molecular nitrogen and hydrocarbon compounds. This reaction is then followed by the oxidation of HCN to NO.

Although prompt NO_x formation normally has a weak temperature dependence, this dependence can become strong under fuel-rich conditions. Except for burners that fully premix air and gaseous fuel, most burners are designed to reduce peak flame temperatures by controlling the rate of fuel and air mixing. Combustion is initiated under fuel-rich conditions, and this fuel-rich zone is where prompt NO_x is formed. Prompt NO_x can contribute from near zero to more than 100 ppm of NO. Burners that are capable of controlling prompt NO_x formation by premixing fuel and air are described in Sect. 5.2.1.6.

3.2.2 Sulfur Dioxide

Sulfur in most fossil fuels is derived primarily from the decay of plant and animal matter. It originates as hydrogen sulfide, a by-product of the decay process. Other sources of sulfur in fuel include iron sulfite and iron sulfate.

Combustion of sulfur-bearing fuels results in the creation of SO₂. The two principle industrial sources of sulfur emissions are fossil fuel combustion and metallurgical ore refining.¹⁰ When SO₂ oxidizes in the atmosphere, it converts to sulfuric acid (H₂SO₄). There are two mechanisms by which sulfuric acid is formed.

1. Gaseous SO₂ can combine with liquid water to form a dilute aqueous solution of sulfurous acid (H₂SO₃), which oxidizes in the atmosphere to form H₂SO₄.
2. Gaseous SO₂ can also oxidize in the atmosphere to produce gaseous SO₃, which combines with water vapor to form H₂SO₄.

In 1970, the average sulfur content of coal burned by coal-fired power plants was 2.3%. Between 1970 and 1988, use of coals with less sulfur reduced this average to 1.34% (Ref. 18). Switching to low-sulfur coals can be an effective way to reduce SO₂ emissions and thereby permit utilities to comply with mandated SO₂ emissions limitations, but it can have adverse effects on boiler performance. As an example, consider the potential consequences of switching from eastern bituminous coal, which has a high heating value and low ash content to a low-sulfur western subbituminous coal with a high ash content, and lower heating value. Flame stability at various loads can be affected, higher slagging and fouling may occur, the ash loading will increase, changes in fuel handling equipment may be required, emissions control equipment may not perform satisfactorily, and emission levels will be different.

If switching to low-sulfur coal is not effective in reducing SO₂ emissions to an acceptable level, use of wet or dry scrubbers is often a viable option. These postcombustion techniques for controlling SO₂ emissions are very efficient, and their installation allows continued use of existing fuel sources, thereby making major changes in boiler operations unnecessary. Depending on the process, by-products from wet scrubbing can include mixtures of calcium sulfate or calcium sulfite that may be sold as gypsum or placed in landfills.¹⁰ Other methods that are effective in reducing SO₂ emissions include using FBC boilers, reducing the sulfur content of fuel directly, and switching to low-sulfur fuel oil or natural gas.

Coal cleaning can also be an effective method for lowering SO₂ emissions by reducing the amount of sulfur in coal before it is burned. After coal is mined, crushed, and screened to achieve size segregation, it may be processed using various techniques, including gravity concentration, flotation, and dry processing.¹⁸ Gravity concentration is a mechanical cleaning technique that uses the difference in specific gravity of the various coal constituents to separate ash and sulfur from the coal. Segregation is achieved when the more dense ash and sulfur particles settle farther and faster in a fluid medium than the less dense coal particles of the same size. The flotation method of coal cleaning uses differences in surface properties to achieve separation. As air passes over the surfaces of coal particles and mineral matter suspended in an aqueous solution, the coal particles float upward because their surfaces are more difficult to wet. This method is generally used for cleaning coal finer than 300 μm. Dry processing of coal is only suitable for material that has been crushed finer than 0.5 in. and has low surface moisture. This method involves pneumatic processing to achieve segregation.

3.2.3 Particulate Matter

Combustion of any fuel that contains noncombustible material results in the formation of ash. The ash as well as any unburned carbon particles are referred to collectively as PM or fly ash. Fine PM includes dust, smoke, and soot, which can be emitted during the combustion of certain fuels such as coal and wood.

Particle size is measured in micrometers or microns (one millionth of a meter). Depending on the concentration, these fine particles can adversely affect breathing and contribute to poor visibility. Separate PM emission limitations have been established for particles with an aerodynamic diameter less than or equal to a nominal 10 μm (PM₁₀) and for particles with an aerodynamic diameter less than or equal to a nominal 2.5 μm (PM_{2.5}).

All coals contain some amount of ash. Eastern bituminous coals typically contain 5 to 15% ash (by weight), while western subbituminous coals contain 5 to 30% ash. The ash content of fuel oils varies depending on whether the fuel is residual or distillate oil. Residual oils have more ash than distillate oils, but both types have much less ash than coal. Natural gas is essentially ash-free, but it can have some small amount of particulate emissions.

Before flue gas is discharged into the atmosphere, it is often necessary to remove as much of the PM as possible. Three techniques currently being used for this purpose, either alone or in combination, include: (1) mechanical collectors, (2) electrostatic precipitators (ESPs), and (3) fabric filters.¹⁰

3.2.4 Carbon Monoxide

Carbon monoxide (CO) is a colorless, odorless gas formed when carbon in fuels is not burned completely. Highway vehicles produce about 60% of all CO emissions in the United States. In certain cities, automobile exhaust causes as much as 95% of all CO emissions. Other sources of CO emissions include industrial processes and fuel combustion in boilers and incinerators. When combined, emissions from these sources can result in high concentrations of CO, particularly in local areas with heavy traffic congestion.

Control of the combustion process is very important to efficient boiler operation. Incomplete fuel combustion represents wasted energy and results in increased CO and PM emissions. Although combustion of liquid and gaseous fuels typically produces very low CO emissions, control of unburned carbon in boilers that burn solid fuel is an important design and operating concern. Carbon burnout is dependent on fuel properties, boiler and firing system characteristics, and unit operating conditions. Major factors influencing complete combustion of carbon include

- fuel reactivity,
- fuel fineness and particle size,

- efficiency of fuel-air mixing,
- excess air available for complete combustion,
- residence time, and
- temperature profile inside the boiler.

To minimize carbon loss, it is important to match these parameters with the fuel's combustion characteristics. In most instances, the loss due to unburned carbon from coal, wood, and other solid fuel combustion is controllable to below 0.5% of the fuel fired.²⁰

3.2.5 Hazardous Air Pollutants

When fuel is burned in a boiler, different types of HAPs can be emitted. In general, their formation depend on the composition of the fuel and the combustion process. Three factors that greatly influence the combustion process include time, turbulence, and temperature. The importance of each factor is a function of the boiler design and the fuel being burned.

Fuel-dependent HAPs can generally be reduced by either changing the composition of the fuel before it is burned or by removing the HAP from the flue gas after combustion occurs. Emissions of metals such as mercury are released along with PM whenever certain solid fuels are burned. Installation of a PM collection system is an effective way to reduce mercury emissions. Acid gases, such as hydrogen chloride, and organic compounds, such as formaldehyde, that can form when fuel combustion is incomplete are released along with the flue gas. Scrubbers designed to lower SO₂ emissions can be effective in reducing these emissions. In general, larger amounts of organic emissions are produced whenever liquid or gaseous fuels are fired compared to solid fuels.

3.3 EFFICIENCY

To minimize the cost of producing steam or hot water, boiler owners and operators are very interested in extracting as much energy from the fuel as possible. In addition to reducing fuel cost, using energy efficiently is an effective way to reduce emissions. When less fuel is burned to produce a given amount of steam or hot water, emissions are reduced. Achieving high efficiency is therefore an important consideration in selecting a low-emission boiler and combustion equipment. However, many of the methods used to reduce emissions come with a price, either in terms of impact to system efficiency or increased operating cost.^{25,26}

The meaning of the term “efficiency” can sometimes be confusing because there are several ways that efficiency can be quantified. When determining efficiency, it is important that all forms of heat loss are considered. Heat loss in this context is energy that is not transferred to the water to increase its energy content but discharged or vented from the system. The goal is to optimize system performance to increase operational flexibility and to minimize impact on the overall system.

In considering factors that influence boiler performance, note that efficiency is not constant throughout the entire operating range of a boiler. Peak efficiency generally occurs at a particular boiler output. Operations that deviate from this output often result in performance that is somewhat below peak efficiency.

Continuous operation at peak efficiency is often impractical because of seasonal demands and load variations, but operation at steady load and avoidance of cyclic or on-off operation can improve efficiency. However, on-off operation can and will reduce overall energy usage, depending on the output requirements.

While every boiler and burner arrangement will perform somewhat differently, it is possible to project variations in efficiency based on boiler load. It is important to understand that efficiency loss can vary as much as 10% when operations change from the maximum continuous rating (MCR) to reduced boiler output (30 to 40% of capacity). The key to increased efficiency involves minimizing all forms of

combustion and boiler losses. In addition, the overall system efficiency can be improved with attention to the application and uses of the steam and hot water produced by the boiler. Improving system efficiency means that less fuel is used to run the entire process, which in turn leads to lower overall emissions.^{25–28}

3.3.1 Combustion Losses

Combustion efficiency is a measure of the chemical energy available in fuel that is liberated by the combustion process. Quantifying combustion efficiency involves determining

- losses from unburned carbon in the flue gas (CO),
- losses from unburned carbon in the solid residue (bottom ash and fly ash), and
- losses from unburned hydrocarbons (UHCs) in the flue gases.

In its simplest form, combustion efficiency can be computed using the following equation:

$$\text{Combustion efficiency} = 100 - (\text{unburned-fuel losses}) . \quad (3.1)$$

Under perfect combustion conditions, the following phenomena can occur.

- Carbon in hydrocarbon fuel combines with oxygen in the combustion air to form CO₂.
- Hydrogen in the fuel combines with oxygen in the combustion air to form water vapor.

Achieving complete combustion requires precise proportioning of the fuel-air mixture. Incomplete combustion due to an imbalance in the fuel-to-air ratio can result in significant energy loss that translates to decreased combustion efficiency.

When insufficient combustion air (oxygen) is available for complete fuel combustion, some of the carbon remains unburned. Incomplete combustion can result in the formation of CO and carbon-laden PM known as soot. If no additional air is made available to complete the combustion process, two forms of energy are wasted. Heat is lost from the system as hot CO gas or soot particles leaving the stack, and energy is not extracted from the unburned or partially burned carbon.

Air supplied to a boiler in excess of that required for complete fuel combustion (excess air beyond stoichiometric conditions) is also detrimental to efficiency. The efficiency reduction results from excess air entering the boiler at ambient temperature and exiting the system at the stack temperature.

3.3.2 Boiler Losses

Boiler efficiency is a function of boiler losses and combustion losses. It can be characterized as the amount of heat captured by the boiler and transferred to the water, divided by the heat that was input. The heat that was not transferred to the water manifests itself in a number of losses that include

- flue-gas losses,
- radiant heat losses,
- blowdown losses, and
- unaccounted losses.

Flue-gas losses are often the primary cause for reduced boiler efficiency. Energy is wasted whenever heated flue gas is carried out of the boiler and up the stack. Flue-gas temperature is related to boiler load. In general, as boiler load increases, the flue-gas temperature increases. Hotter flue-gas temperatures increase flue-gas losses. Installation of equipment to recover some of this heat can have a beneficial effect on efficiency, but removing too much heat can cause problems such as corrosion,

especially when water condenses on boiler equipment. Corrosion of internal boiler components made from certain types of steel, such as carbon steel, can occur at locations where water condenses and combines with other constituents in the flue gas to form acids. Use of stainless steel or other alloys is sometimes required to avoid these corrosion problems. For most boiler systems, there is a practical limit that dictates the minimum flue-gas temperature.

Air in excess of that required for complete fuel combustion represents a major flue-gas loss. Because the fuel supplies energy required to increase the temperature of excess air, controlling the amount of air that is supplied to a boiler has a direct impact on boiler efficiency. The loss is a function of the amount of excess air that passes through the boiler and the temperature of the excess air that discharges from the stack. Energy required to raise the temperature of excess air is wasted because it is not used to heat water. If the water vapor content of the excess air is high, even more energy is required to superheat the water vapor. Although combustion of any fuel results in some degree of flue-gas loss, solid fuels require more excess air for complete combustion than do gaseous fuels.

Although combustion with insufficient air decreases combustion efficiency, it is a very effective technique for reducing NO_x formation. A lower flame temperature associated with incomplete combustion decreases the amount of thermal NO_x that forms. Selection of a low-emission boiler and combustion equipment often requires a compromise between efficiency and NO_x formation. For greatest efficiency, a boiler should be fitted with proper combustion equipment, including a control system that is capable of adjusting the fuel-air mixture so that little or no CO and soot are produced. Additional air that is required to complete the combustion process is sometimes provided in stages. Staged combustion is a NO_x control technique based on the fact that combustion at either very low or very high excess air levels results in reduced NO_x formation. By mixing air and fuel at two or more locations inside a boiler, it is possible to create zones with high and low excess air levels. Air that is injected into a boiler at different points or stages in the combustion process is known as staged combustion air (SCA). The NO_x control techniques based on this concept are described in Sect. 5.2.1. New boilers and combustion equipment that are well-designed are capable of achieving both high efficiency and low NO_x formation. However, for existing boilers, changes in firing profile may change the absorption profile, temperature profile, and carbon burnout of a boiler, thereby affecting boiler efficiency.

The reaction of hydrogen atoms in fuel with oxygen molecules in air produces heat and water vapor. When the water vapor leaves the stack, it reduces the available energy by carrying away the associated latent heat of vaporization. Reducing the temperature of the flue gas as a means of lowering the heat loss is an effective way to conserve energy, but it can lead to serious corrosion problems. Because natural gas has a relatively high hydrogen content when compared to coal, this form of heat loss is higher for natural-gas-fired boilers than for comparable size coal-fired boilers.

Moisture in fuel represents another form of heat loss. Like the phenomenon just described, the water vapor leaving the stack reduces the available energy by carrying away the associated latent heat of vaporization. As water vapor from the fuel is superheated, additional heat loss is experienced. The wasted energy from this form of heat loss can be significant for solid fuels but tends to be less for gaseous fuels, which usually have a lower moisture content.

Radiant heat loss consists of both radiant and convection heat losses from the outer surfaces of a boiler, which are typically above ambient temperature. These losses do not vary significantly in magnitude with boiler load because the outer surface temperature of the boiler remains essentially constant while in operation. However, these losses as a percentage of boiler output get worse whenever the load diminishes. Two ways to reduce radiant heat loss include adding thermal insulation to outer boiler surfaces and operating the boiler at the lowest temperature consistent with system and boiler manufacturer requirements.

Buildup of soluble salts and accumulation of other solids in the water passages of a boiler can impede heat transfer and eventually restrict flow through boiler passages. Use of chemicals that impede scaling and regular blowdowns can help control this problem, but the hot water and solid particles that discharge during a blowdown represent wasted energy. Installing a heat recovery system can reduce

boiler losses due to blowdowns. By using chemicals to control scaling, it may be possible to reduce the blowdown rate. Note that blowdown heat recovery equipment is usually cost-effective only for systems that use continuous rather than intermittent blowdown.

A relatively small but important form of heat loss is characterized as unaccounted losses. These losses, which are not related to the combustion process, are associated with cyclic rather than continuous boiler operations. They include prepurge and postpurge losses, natural-draft losses, and off-line shell losses. Prepurge and postpurge losses involve forcing air through the boiler to remove unburned combustibles before startup and after shutdown. When this operation is performed, the flowing air removes some thermal energy from the boiler. Similar to purging losses, natural-draft losses occur when the boiler is shut off and air circulates naturally through the boiler. Off-line shell losses are radiant heat losses that occur after the boiler is shut off. Firetube boilers typically have off-line shell losses much less than comparable size watertube boilers because the shell temperature of a firetube boiler is more of a function of the water temperature than the combustion gas temperature.

Heating systems for commercial buildings typically exhibit a wide range of heating demands throughout the heating season. To minimize unaccounted heat losses associated with cyclic operation, there may be advantages in selecting multiple boilers instead of one or two large boilers. In this approach, at least some of the smaller units operate more or less continuously.

3.4 REFERENCES

1. "Standard Terminology of Coal and Coke," ASTM D 121, American Society for Testing and Materials, West Conshohocken, Pennsylvania, 1999.
2. "Standards of Performance for Industrial-Commercial-Institutional Steam Generating Units," 40 CFR 60, Db, U.S. Environmental Protection Agency.
3. D. A. Wulfinghoff, *Energy Efficiency Manual*, Energy Institute Press, Wheaton, Maryland, 1999.
4. "Standards of Performance for Electric Utility Steam Generating Units for Which Construction is Commenced After September 18, 1978," 40 CFR 60, Da, U.S. Environmental Protection Agency.
5. "Standard Specification for Fuel Oils," ASTM D 396, American Society for Testing and Materials, West Conshohocken, Pennsylvania, 1998.
6. "Standard Specification for Liquefied Petroleum (LP) Gases," ASTM D 1835, American Society for Testing and Materials, West Conshohocken, Pennsylvania, 1997.
7. "Standards of Performance for Fossil-Fuel-Fired Steam Generating Units for Which Construction is Commenced After August 17, 1971," 40 CFR 60, D, U.S. Environmental Protection Agency.
8. H. Taplin, *Combustion Efficiency Tables*, The Fairmont Press, Inc., Lilburn, Georgia, 1991.
9. T. C. Elliott, *Standard Handbook of Powerplant Engineering*, McGraw-Hill Publishing Company, New York, 1989.
10. E. B. Woodruff, H. B. Lammers, and T. F. Lammers, *Steam Plant Operation*, 7th ed., McGraw-Hill Companies, Inc., New York, 1998.
11. "Standard Specification for Coal Fly Ash and Raw or Calcined Natural Pozzolan for Use as a Mineral Admixture in Concrete," ASTM C 618, American Society for Testing and Materials, West Conshohocken, Pennsylvania, 1999.
12. "Standard Classification of Coal by Rank," ASTM D 388, American Society for Testing and Materials, West Conshohocken, Pennsylvania, 1999.
13. "Standard Test Method for Moisture in the Analysis Sample of Coal and Coke," ASTM D 3173, American Society for Testing and Materials, West Conshohocken, Pennsylvania, 1996.
14. "Standard Test Method for Ash in the Analysis Sample of Coal and Coke from Coal," ASTM D 3174, American Society for Testing and Materials, West Conshohocken, Pennsylvania, 1997.
15. "Standard Test Method for Total Sulfur in the Analysis Sample of Coal and Coke," ASTM D 3177, American Society for Testing and Materials, West Conshohocken, Pennsylvania, 1997.

16. "Standard Test Method for Total Moisture in Coal," ASTM D 3302, American Society for Testing and Materials, West Conshohocken, Pennsylvania, 1999.
17. "Standard Test Method for Gross Caloric Value of Coal and Coke," ASTM D 5865, American Society for Testing and Materials, West Conshohocken, Pennsylvania, 1999.
18. *Steam, Its Generation and Use*, 40th ed., ed. S. C. Stultz and J. B. Kitto, Babcock and Wilcox, Barberton, Ohio, 1992.
19. *North American Combustion Handbook, Volume 1: Combustion, Fuels, Stoichiometry, Heat Transfer, Fluid Flow*, 3rd ed., North American Manufacturing Company, Cleveland, Ohio, 1986.
20. *Combustion Fossil Power*, 4th ed., ed. J. G. Singer, Combustion Engineering, Inc., Windsor, Connecticut, 1991.
21. *The Clean Air Amendments Act: Updated Strategies*, TRC Environmental Corporation, Windsor, Connecticut, and Hale and Door, Washington, D.C., 1994.
22. "Primary and Secondary National Ambient Air Quality Standards," 40 CFR 50, U.S. Environmental Protection Agency.
23. H. Soud, *Suppliers of FGD and NO_x Control Systems*, IEACR/83, IEA Coal Research, London, United Kingdom, November 1995.
24. "Standard Test Method for Oxides of Nitrogen in Gaseous Products (Phenol-Disulfonic Acid Procedures)," ASTM D 1608, American Society for Testing and Materials, West Conshohocken, Pennsylvania, 1998.
25. *Energy Efficiency Handbook*, ed. R. A. Zeitz, Council of Industrial Boiler Owners, Burke, Virginia, November 1997.
26. G. Harrell, *Steam System Survey Guide*, ORNL/TM-2001/263, Oak Ridge National Laboratory, Oak Ridge, Tennessee, 2002.
27. *Combustion Control Guidelines for Single Burner Firetube and Watertube Industrial/Commercial/Institutional Boilers*, American Boiler Manufacturers Association, Arlington, Virginia, 1999.
28. *Combustion Control Guidelines for Multiple Burner Boilers*, American Boiler Manufacturers Association, Arlington, Virginia, 2002.

4. EMISSIONS STANDARDS AND COMPLIANCE ISSUES

Emissions standards for air quality in the United States have been established to address a variety of concerns about atmospheric pollution on the human and natural environment.¹ Specific concerns include an increase in ground-level ozone, the accumulation of fine particles in the atmosphere, the development of acid rain, the acidification of aquatic systems, visibility limitations, and releases of HAPs.

Ground-level ozone is created by a chemical reaction between VOCs and oxides of nitrogen. When these materials react in the presence of sunlight, they form ground-level ozone, a major ingredient of smog. Fine PM includes dust, smoke, and soot, which typically measure 10 µm in diameter or less. The principal sources of acidic compounds, including acid rain, involve emissions of SO₂ and NO_x. The HAPs are of concern because they involve substances that may be carcinogens, mutagens, or reproductive toxins.

4.1 CLEAN AIR ACT

In 1970, the CAA established a major role for the federal government in regulating air quality.² This regulation was further expanded by amendments in 1977 and 1990. The 1990 Clean Air Act Amendments (CAAA) authorize the EPA to establish standards for a number of atmospheric pollutants.³ They also authorize EPA and state agencies to bring civil and criminal actions against violators of the statutes.

The CAA is extremely lengthy and complex. Compliance with applicable portions of the regulation requires an understanding of the original act that was signed into law in 1970, the various amendments that have since been adopted, changes promulgated by EPA, and numerous rulings issued by the judicial system.

The 1990 CAAA are subdivided into the following seven major titles that address specific air quality and pollution issues.

- Title I: Provisions for Attainment and Maintenance of National Ambient Air Quality Standards (NAAQS)
- Title II: Provisions Relating to Mobile Sources
- Title III: Air Toxics
- Title IV: Acid Deposition Control
- Title V: Permits
- Title VI: Stratospheric Ozone and Global Climate Protection
- Title VII: Provisions Relating to Enforcement

Requirements in Titles I, III, IV, and V have, or may have in the future, an impact on both new and existing combustion boilers.⁴

Title I contains requirements for effectively achieving national air quality goals. Under Sect. 109, EPA is authorized to establish primary and secondary NAAQS. These standards represent the maximum allowable concentration of a pollutant permitted in the ambient air. Primary ambient air quality standards define levels of air quality that are considered necessary, with an adequate margin of safety, to protect the public health. Secondary ambient air quality standards are intended to protect the public welfare from any known or adverse effects of a pollutant. Both standards are subject to revision, and additional primary and secondary standards may be promulgated, as the EPA Administrator deems necessary to protect the public health and welfare.

Under Sect. 110 of Title I, states are required to adopt plans for implementing, maintaining, and enforcing NAAQS in each air quality control region within its jurisdiction. Such plans are known as State Implementation Plans (SIPs). These plans establish emission standards for specific sources. To achieve compliance, states are subdivided into a number of identifiable areas known as air quality control regions in which at least the minimum NAAQS must be met or control requirements imposed. If the level

of a regulated pollutant exceeds the specified federal standard within a particular region, it is classified as a nonattainment area (NAA). When a region fails to meet a NAAQS, more stringent emission control requirements, designed to reduce emission levels and thereby achieve attainment, must be applied. As in prior environmental legislation, local or state environmental regulatory agencies may impose stricter regulations on individual sources or areas.

Authorization for EPA to establish performance standards for new stationary sources is provided in Sect. 111 of Title I. These New Source Performance Standards (NSPS) establish maximum emission rates for selected pollutants from new steam generating units and existing units that undergo substantial modifications. This legislation ensures that standard emissions controls are applied uniformly in all areas, irrespective of ambient air quality considerations. According to the legislation, the degree of emissions limitation is achieved through the application of the best system of emission reduction, which has been adequately demonstrated.

Title III amended Sect. 112 of the CAA regarding requirements for reducing emissions of toxic air pollutants. Toxic air pollutants are those pollutants that are hazardous to human health or the environment but are not specifically covered under another portion of the CAA. The CAA of 1990 includes a comprehensive plan for achieving significant reductions in emission of HAPs from major sources. Section 112 includes a list of toxic air pollutants for which emissions must be reduced. Often characterized as carcinogens, mutagens, or reproductive toxins, these pollutants are typically subdivided into the following groups:

- metals, including cadmium, mercury, lead, and PM;
- organics, including dioxins and furans; and
- acid gases, including hydrogen chloride, SO₂, and NO_x.

To establish regulations for these pollutants, EPA developed and published a list of source categories that emit 10 tons/year of any one or 25 tons/year of any combination of those pollutants. Based on this list, EPA has either issued or is now developing Maximum Achievable Control Technology (MACT) standards for each listed source category. These standards are based on the best demonstrated control technology or practice within the regulated industry. Currently, EPA has established MACT standards for certain HAP sources, including large municipal waste combustion units. Standards for ICI boilers that burn fossil fuels are under development. From a boiler emissions viewpoint, mercury and hydrogen chloride are the two HAPs that will likely be regulated.

When developing a MACT standard for a particular source category, EPA looks at the level of emissions currently being achieved by the best-performing similar sources through clean processes, control devices, work practices, or other methods. These emissions levels set a baseline (often referred to as the “MACT floor”) for the new standard. At a minimum, a MACT standard must achieve, throughout the industry, a level of emissions control that is at least equivalent to the MACT floor. The MACT floor is established differently for existing sources and new sources. For existing sources, the MACT floor must equal the average emissions limitations currently achieved by the best-performing 12% of sources in that source category, provided there are 30 or more existing sources within the category. If there are fewer than 30 existing sources, then the MACT floor must equal the average emissions limitation achieved by the best-performing five sources in the category. For new sources, the MACT floor must equal the level of emissions control currently achieved by the best-controlled similar source. Wherever feasible, EPA writes the final MACT standard as an emissions limit (i.e., as a percent reduction in emissions or a concentration limit that regulated sources must achieve). Emissions limits provide flexibility for industry to determine the most effective way to comply with the standard.

Title IV establishes requirements for significantly reducing NO_x and SO₂ emissions. To achieve this statutory goal, EPA established the Acid Rain Program. Its objective is to reduce adverse effects of acid deposition by controlling SO₂ and NO_x emissions from fossil-fuel-fired power plants. Requirements for SO₂ emissions are contained in Sect. 403. This section addresses the SO₂ allowance program for new and

existing units. Separate requirements for NO_x emissions are provided in Sect. 407. These requirements are part of the EPA's NO_x emission reduction program. Acid Rain Program regulations have been codified in Title 40, Subchapter C of the *Code of Federal Regulations*.⁵⁻⁹

Title V contains legislation covering federal and state air permitting programs that apply to major sources of atmospheric pollution. Specific definitions of major sources are spelled out in Sects. 112 and 302 of the legislation. Each permit issued under this title must include enforceable emission limitations and standards, a schedule of compliance, and a requirement that the permit applicant submit the results of required monitoring to the permitting authority.

Regulations that provide for the establishment of comprehensive state air quality permitting systems consistent with Title V requirements are contained in 40 CFR Part 70 (Ref. 10). Additional regulations that establish certain general provisions and the operating permit program requirements for affected sources and affected units under the Acid Rain Program are contained in 40 CFR Part 72 (Ref. 5). Units affected by this regulation are identified in 40 CFR 72.6 and 40 CFR Part 74 (Ref. 6).

4.1.1 National Ambient Air Quality Standards

The NAAQS for six criteria pollutants, including ozone (O₃), NO_x, SO₂, CO, PM, and lead have been codified in 40 CFR Part 50 (Ref. 11). The primary and secondary standards for each of these pollutants except lead are summarized in Table 4.1 and described below. Standards for lead are not covered in this guide because it is not a major pollutant from combustion boilers that burn fossil fuels. Principal sources of lead include leaded gasoline (being phased out), paint (houses and cars), smelters (metal refineries), and manufacture of lead-acid storage batteries. Currently, the only boilers that must comply with lead emission standards are large municipal waste combustion units.¹²

Areas where the level of a criteria pollutant is above the primary standard are considered NAAs. The NAAs are subject to more stringent requirements aimed at reducing emissions to achieve attainment. Attainment areas include areas where the level of a criteria pollutant is below the primary standard. As the regulation is written, it is possible for a source to be located in an area that is classified as an NAA for one or more pollutants and an attainment area for the others.

Owners and operators of boiler systems that meet criteria established by EPA must obtain a permit from the regulatory authority having jurisdiction before the system can be operated. The emission controls that must be installed and the conditions under which the system is allowed to operate often vary from one location to another. This variation is due to the local air quality and the degree to which the local atmospheric conditions deviate from the NAAQS. In general, systems located in attainment areas are allowed to release more pollutants into the atmosphere than systems located in NAAs.

4.1.1.1 Ozone

Ozone NAAs are classified according to the severity of each area's air pollution problem. These classifications are marginal, moderate, serious, severe, and extreme. Each NAA is assigned to one of these categories, thus triggering varying requirements with which the area must comply to meet the ozone standard. According to the regulation, NAAs must implement different control measures, depending on their classification. Marginal areas, for example, are the closest to meeting the standard. They are required to conduct an inventory of their ozone-causing emissions and institute a permit program. The NAAs with more serious air quality problems must implement various other control measures. In general, areas with the worst air quality must implement the most stringent emission controls.

Table 4.1. Summary of NAAQS under Title I of the CAA^a

Criteria pollutant	Primary standards	Secondary standards
O ₃ 40 CFR 50.9 and 50.10	The primary 1-h ambient air quality standard for ozone is 0.12 ppm, daily maximum 8-h average. This standard is attained when the expected number of days per calendar year with maximum hourly average concentrations above 0.12 ppm is equal to or less than one. The primary 8-h ambient air quality standard for ozone is 0.08 ppm, daily maximum 8-h average. This standard is met at a monitoring site when the average of the annual fourth-highest daily maximum 8-h average of ozone concentration is less than or equal to 0.08 ppm.	The secondary ambient air quality standards for ozone are the same as the primary standards.
NO ₂ 40 CFR 50.11	The primary ambient air quality standard for NO ₂ is 0.053 ppm, annual arithmetic mean concentration.	The secondary ambient air quality standards for NO ₂ are the same as the primary standards.
SO ₂ 40 CFR 50.4 and 50.5	The primary annual ambient air quality standard for SO ₂ is 0.030 ppm, not to be exceeded in a calendar year. The 24-h standard is 0.14 ppm, not to be exceeded more than once per calendar year.	The secondary 3-h ambient air quality standard for SO ₂ is 0.5 ppm, not to be exceeded more than once per calendar year.
CO 40 CFR 50.8	The primary ambient air quality standards for CO are 9 ppm for an 8-h average concentration not to be exceeded more than once per calendar year, and 35 ppm for a 1-h average concentration not to be exceeded more than once per calendar year.	There are no secondary ambient air quality standards for CO.
PM up to 10 µm in diameter (PM ₁₀) 40 CFR 50.6	The primary 24-h ambient air quality standard for PM ₁₀ is 150 µg/m ³ , 24-h average concentration. The primary annual ambient air quality standard for PM ₁₀ is 50 µg/m ³ , annual arithmetic mean concentration.	The secondary ambient air quality standards for PM ₁₀ are the same as the primary standards.
PM up to 2.5 µm in diameter (PM _{2.5}) 40 CFR 50.7	The primary 24-h ambient air quality standard for PM _{2.5} is 65 µg/m ³ , 24-h average concentration. The primary annual ambient air quality standard for PM _{2.5} is 15.0 µg/m ³ , annual arithmetic mean concentration.	The secondary ambient air quality standards for PM _{2.5} are the same as the primary standards.

^aConsult 40 CFR 50 for NAAQS details (Ref. 11).

In 1997, EPA reviewed the air quality standard for ground-level ozone and established the primary and secondary 8-h NAAQS for ozone at 0.08 ppm and the primary and secondary 1-h NAAQS for ozone at 0.12 ppm (Refs. 11 and 13).

4.1.1.2 Nitrogen oxides

Many urban areas do not meet the ozone standard and are classified as NAAs. To address this problem as well as regional pollution transport, more restrictive requirements were established for NO_x emissions from electric power generating plants and other large stationary boilers in 22 eastern states and the District of Columbia. The requirements set statewide NO_x emissions budgets, including budget components for the electric power industry and certain industrial sources. To achieve the required statewide emissions budgets, states are required to develop SIPs that include NO_x emission limits for specific sources. The NO_x emissions by source are identified in Table 4.2.

Table 4.2. Emissions by source of NO_x and SO₂ in the United States

Emissions source	NO_x (%)	SO₂ (%)
Utilities	27	67
Transportation	49	5
Industrial/commercial/residential	19	21
Other	5	7

Source: <http://www.epa.gov>

According to regulations in 40 CFR 50.11 (Ref. 11), the primary and secondary ambient air quality standards for NO₂ are 0.053 ppm, annual arithmetic mean concentration. In addition to these standards, Title I of the CAA includes provisions designed to address both the continued nonattainment of the existing ozone NAAQS and the transport of air pollutants across state boundaries. These provisions allow downwind states to petition for tighter controls on upwind states that contribute to their NAAQS nonattainment status. In general, Title I NO_x provisions require areas with an ozone nonattainment region to (1) require existing major stationary sources to apply RACT; (2) require new or modified major stationary sources to offset their emissions and install controls representing the LAER; and (3) require each state with an ozone nonattainment region to develop a SIP that, in some cases, includes reductions in stationary source NO_x emissions beyond those required by the RACT provisions of Title I, if needed to attain the ozone NAAQS.⁴ RACT is defined as the lowest emission limitation that a particular source is capable of meeting by application of control technology that is reasonably available, considering technological and economic feasibility. It also represents the minimum requirement that EPA can accept for existing sources in nonattainment state plans.¹⁴ LAER is defined as the emissions rate required on major new or modified sources in NAAs.

Section 184 of the CAA delineates a multistate ozone transport region (OTR) in the northeast and requires specific additional NO_x and VOC controls for all areas in this region. It also establishes the Ozone Transport Commission (OTC) for the purpose of assessing the degree of ozone transport in the OTR and recommending strategies to mitigate the interstate transport of pollution. The OTR consists of the states of Connecticut, Delaware, Maine, Maryland, Massachusetts, New Hampshire, New Jersey, New York, Pennsylvania, Rhode Island, Vermont, parts of northern Virginia, and the District of Columbia. The OTR states confirmed that they would implement RACT on major stationary sources of NO_x (Phase I) and agreed to a phased approach for additional controls, beyond RACT, for power plants and other large fuel combustion sources (Phases II and III). This agreement, known as the OTC

Memorandum of Understanding (MOU) for stationary source NO_x controls was approved on September 27, 1994. All OTR states, except Virginia, are signatories to the OTC NO_x MOU.⁴

The MOU establishes an emissions trading system for the various OTR jurisdictions to reduce the costs of compliance with the control requirements under Phase II (which began on May 1, 1999) and Phase III (beginning on May 1, 2003). The OTC program caps summer season (May 1 through September 30) NO_x emissions for all 13 OTR jurisdictions are approximately 219,000 tons in 1999, and 143,000 tons in 2003, which represent approximately 55 and 70% reductions in NO_x, respectively, from the 1990 baseline emission level of 490,000 tons.

To address long-range transport of ozone, EPA promulgated a rule on October 27, 1998, known as the NO_x SIP call.¹⁵ The purpose for this rule is to limit summer season NO_x emissions in 22 northeast states and the District of Columbia that EPA considers significant contributors to ozone nonattainment in downwind areas. These states were required to amend their SIPs through a procedure established in Sect. 110 of the CAA. EPA finalized a summer-season state NO_x budget (in tons of NO_x) and developed a state implemented and federally enforced NO_x trading program to provide for emissions trading by certain electric and industrial stationary sources. Each affected state's NO_x budget is based on the application of a population-wide 0.15-lb/MBtu NO_x emission rate for large electricity generating units and a 60% reduction from uncontrolled emissions for large nonelectricity generating units. This effort is projected to reduce summer-season NO_x emissions by 1.1 million tons in the affected 22 states and the District of Columbia. EPA issued revised budgets for NO_x emissions for each of the 23 jurisdictions included in the NO_x SIP call on March 2, 2000.¹⁶

In addition to promulgating the NO_x SIP call, EPA responded to petitions filed by eight northeastern states under Sect. 126 of the CAA. The petitions, which are known as Section 126 Petitions, request that EPA make a finding that NO_x emissions from certain major stationary sources significantly contribute to ozone nonattainment problems in the petitioning states. The final Sect. 126 rule requires upwind states to take action to reduce emissions of NO_x that contribute to nonattainment of ozone standards in downwind states.^{17,18} The findings affect large electric generating units and both nonelectric generating boilers and turbines located in 12 northeast states and the District of Columbia. Similar to the NO_x SIP call, EPA has finalized a federal NO_x Budget Trading Program based on the application of a population-wide 0.15-lb/MBtu NO_x emission rate for large electric generating units and a 60% reduction from uncontrolled emissions for large nonelectric generating units. The final Sect. 126 actions are projected to reduce summer-season NO_x emissions by 510,000 tons in the 12 affected states and the District of Columbia. The compliance deadline was initially set for May 1, 2003 (Ref. 4) but has now been extended to May 31, 2004.

An overview of regulatory actions concerning NO_x emissions that affect specific regions of the United States is presented in Table 4.3.

4.1.1.3 Sulfur dioxide

Separate primary and secondary NAAQS have been established for SO₂ emissions.¹¹ The maximum allowable SO₂ emissions levels for each of these categories are presented in Table 4.1.

4.1.1.4 Carbon monoxide

The primary NAAQS for CO are

- 9 ppm (10 mg/m³) for an 8-h average concentration not to be exceeded more than once per year, and
- 35 ppm (40 mg/m³) for a 1-h average concentration not to be exceeded more than once per year.¹¹

There are no secondary NAAQS for CO emissions.

Table 4.3. Selected NO_x reduction regulations under Titles I and IV of the CAA

Title	Regulatory action	Affected regions	Compliance date	Control period	NO _x reductions
I	OTC NO _x Budget Program	12 States and DC: CT, DE, ME, MD, MA, NH, NJ, NY, PA, RI, VT, VA	Phase II: May 1, 1999 Phase III: May 1, 2003	Ozone season (May 1 through September 30)	246,000 tons in 1999 322,000 tons in 2003
	NO _x SIP call	22 States and DC: AL, CT, DE, GA, IL, IN, KY, MD, MA, MI, MO, NJ, NY, NC, OH, PA, RI, SC, TN, VA, WV, WI	May 1, 2003	Ozone season (May 1 through September 30)	1.1 million tons in 2007
	Section 126 rule	12 States and DC: DE, IN, KY, MD, MI, NJ, NY, NC, OH, PA, VA, WV	Initially May 1, 2003, but now May 31, 2004	Ozone season (May 1 through September 30)	510,000 tons in 2007
IV	Acid Rain Program	Nationwide	Phase I of the NO _x Program: January 1, 1996 Phase II: January 1, 2000	Annual	340,000 tons/year in Phase I 2.06 million tons/year in Phase II
	Revised NO _x NSPS	Nationwide	July 9, 1997	Annual	25,800 tons/year

Source: Ref. 4.

Areas exceeding the standards for CO are divided into moderate and serious classifications. Depending on the degree to which they exceed the standard, areas are required to implement programs introducing oxygenated fuels or enhanced emission inspection programs, among other measures.³

4.1.1.5 Particulate matter

In 1997, EPA reviewed the air quality standard for PM and revised the NAAQS.^{11,13} Requirements for PM with an aerodynamic diameter up to 10 µm (PM₁₀) were retained, while requirements for PM with an aerodynamic diameter up to 2.5 µm (PM_{2.5}) were added.

The maximum allowable primary and secondary NAAQS for PM emissions are presented in Table 4.1. To attain this standard, the following conditions for both PM₁₀ and PM_{2.5} must apply.

For PM₁₀:

- The arithmetic average of the 24-h samples for a period of 1 year, averaged over 3 consecutive years, must not exceed 50 µg/m³.
- The 99th percentile of the distribution of the 24-h concentrations for a period of 1 year, averaged over 3 years, must not exceed 150 µg/m³ at each monitor within an area.

For PM_{2.5}:

- The 3-year average of the annual arithmetic mean of the 24-h concentrations from single or multiple population-oriented monitors must not exceed 15 µg/m³.

- The 98th percentile of the distribution of the 24-h concentrations for a period of 1 year, averaged over 3 years, must not exceed 65 $\mu\text{g}/\text{m}^3$ at each monitor within an area.

Based on their classification, owners and operators of boiler systems located in areas that exceed the PM standard are required to implement either reasonably available control measures (RACM) or best available control measures (BACM), among other requirements.³

4.1.2 Emissions from Existing Steam Generating Units

Title IV of the CAA established a goal of reducing SO_2 and NO_x emissions from fossil-fuel-fired power plants compared to 1980 levels. Based on the legislation, a goal was established to reduce annual SO_2 emissions by 10 million tons and NO_x emissions by 2 million tons by 2000. To achieve this objective, EPA established the Acid Rain Program, which involved a two-phased strategy for tightening the SO_2 and NO_x emissions restrictions.

The Acid Rain Program for SO_2 emissions represents a dramatic departure from traditional command and control regulatory methods, which establish specific, inflexible emissions limitations with which all affected sources must comply. Instead, the Acid Rain Program introduces an allowance trading system to reduce pollution.¹⁹ Under this system, affected utility units are allocated allowances based on their historic fuel consumption and a specific emissions rate. Each allowance permits a unit to emit 1 ton of SO_2 during or after a specified year. For each ton of SO_2 discharged in a given year, one allowance is retired; that is, it can no longer be used. Allowances may be bought, sold, or banked. Any person may acquire allowances and participate in the trading system. However, regardless of the number of allowances a source holds, it may not emit at levels that would violate federal or state limits. To restrict emissions and ensure that environmental benefits are achieved and maintained, a permanent annual ceiling (or cap) of 8.95 million allowances for allocation to utilities has been established for Phase II beginning on January 1, 2000.

The Acid Rain Nitrogen Oxides Reduction Program is also implemented in two phases, beginning in 1996 and 2000. Although this program is results-oriented, it does not cap NO_x emissions as the SO_2 program does. The NO_x emissions limits for existing boilers are based on a maximum allowable emission rate expressed in pounds of NO_x per million British thermal units of heat input.²⁰ Note that, although there are no federal caps on NO_x emissions, three cap-and-trade programs for regional control of NO_x emissions have been established. They include the OTC NO_x Budget Program with NO_x emission allowances set by OTC, Sect. 126 Federal NO_x Budget Trading Program, and the NO_x SIP Call Program in which states have options of participating in the trading program and establishing unit allocations. More information about each of these EPA-administered programs is presented in the NO_x part of Sect. 4.1.1.

4.1.2.1 Sulfur dioxide reduction program

Phase I of the SO_2 reduction program began on January 1, 1995, and extended to December 31, 1999. During that time, 110 mostly coal-burning electric utility power plants located in 21 midwestern and northeastern states were required to reduce SO_2 emissions. Affected plants and associated units are identified in 40 CFR 73, Subpart B.¹⁹ To provide a cost-effective approach for SO_2 reductions, each affected unit was issued SO_2 emission allowances equal to 2.5 lb/MBtu of heat input multiplied by 40% of the unit's 1985–1987 fuel consumption. Each allowance permitted the emission of 1 ton of SO_2 in a given year or any year thereafter. According to the rules, allowances can be bought and sold on the open market, and unused allowances can be sold or banked for future use. This market-based allowance trading system provided the plant owner the option of either reducing emissions or acquiring additional allowances from other plants to cover the actual emissions. Methods of reducing emissions included employing energy conservation measures, increasing reliance on renewable energy, reducing usage,

employing pollution control technologies, switching to lower sulfur fuel, or developing alternate strategies.

In Phase II, which began on January 1, 2000, emission limits imposed on Phase I plants were tightened, and emission limits were also imposed on smaller, cleaner units.¹⁹ Allowance allocation calculations are made for various types of units, such as coal-fired and gas-fired units with low and high emissions rates or low fuel consumption. EPA allocates allowances to each unit at an emission rate of 1.2 lb/MBtu of heat input, multiplied by the unit's baseline. During Phase II, EPA can issue no more than 8.95 million allowances to units in a given year. This effectively caps emissions at 8.95 million tons annually and ensures that the mandated emissions reductions are maintained over time.

Additional SO₂ emitting sources that did not receive allocations as part of Phase I or Phase II can be issued allowances through the EPA's Opt-in Program.⁶ This program, which is authorized under Sect. 410 of the CAAA of 1990, expands EPA's Acid Rain Program by providing the opportunity for other participants to enter the program on a voluntary basis, reduce their SO₂ emissions, and receive their own acid rain allowances. EPA has determined that participation of these additional sources can be cost-effective. If a participating source can reduce its SO₂ emissions at a relatively low cost, its reduction, in the form of allowances, can be transferred to electric utilities where emission reductions are more expensive. The Opt-in Program offers a combustion source a financial incentive to voluntarily reduce its SO₂ emissions. By reducing emissions below its allowance allocation, an opt-in source will create unused allowances, which it can sell in the SO₂ allowance market. Opting in is profitable when the revenue from allowances exceeds the combined cost of the emissions reduction and the cost of participating in the Opt-in Program. Participation in the Opt-in Program requires an opt-in permit based on permitting procedures provided in 40 CFR 74, Subpart B.⁶

4.1.2.2 Nitrogen oxides reduction program

Phase I of the Acid Rain Nitrogen Oxides Reduction Program establishes NO_x emission limits for Group 1 boilers.²⁰ These boilers, which included only dry-bottom, wall-fired, and tangentially fired units, are located at plants identified in 40 CFR 73, Subpart B.¹⁹ As a result of Phase I activities, NO_x emissions declined by more than 400,000 tons/year. This decline was achieved primarily by the installation of low-NO_x burners on these boilers. Phase I ended on December 31, 1999.

In Phase II, lower emissions limits were set by EPA for certain Group I boilers, and emissions limits were established for Group 2 boilers. Group 2 boilers include those applying cell-burner technology, cyclone boilers, wet-bottom boilers, and other types of coal-fired boilers. In establishing these limits, EPA determined that more effective low-NO_x burner technology is available to establish more stringent standards for Phase II, Group 1 boilers than those established for Phase I, and it established limits for Group 2 boilers based on NO_x control technologies that are comparable in cost to low-NO_x burners. For Group I boilers, annual average emission rates for dry-bottom and wall-fired boilers is set at 0.46-lb/MBtu heat input and 0.40-lb/MBtu heat input for tangentially fired boilers. Some Group I boilers are not affected by the Phase II rates and will continue to comply with the Phase I annual average emission rates of 0.50 lb/MBtu for dry-bottom and wall-fired and 0.45 lb/MBtu for tangentially fired boilers.

The statute allows for emissions averaging in which the emissions levels established by EPA are applied to an entire group of boilers owned or operated by a single company. It is estimated that the more stringent Phase II limits will result in an additional NO_x reduction of 820,000 tons/year. The Phase II limits are 0.68 lb/MBtu for cell-burners, 0.86 lb/MBtu for cyclones greater than 155 MW(e), 0.84 lb/MBtu for wet-bottom boilers greater than 65 MW(e), and 0.80 lb/MBtu for vertically fired boilers. As a result of Phase II activities, NO_x emissions are expected to decline by approximately 2.06 million tons/year.

A utility can choose to comply with the rule in one of three ways: (1) meet the standard annual emission limits; (2) average the emissions rates of two or more boilers, which allows utilities to

over-control at units where it is technically easier and less expensive to control emissions; or (3) if a utility cannot meet the standard emission limit, it can apply for a less stringent alternative emission limit (AEL) if it uses the appropriate NO_x emission control technology on which the applicable emission limit is based. EPA's determination of an AEL is based on evidence that control equipment was properly designed, installed, and operated during a demonstration period.

To employ a more flexible emissions trading approach, an option was devised whereby a state (or group of states) could petition EPA to accept an emissions cap-and-trade program as a substitute for compliance with the Group 2 limits and incremental reductions required of Group 1 boilers as set forth in the final rule 61 FR 67156 (Ref. 21). Under this option, the EPA administrator retains the authority to provide relief for boilers that are subject to a cap-and-trade program under Title I from emission limits established in the final rule. The relief is contingent on the EPA administrator finding that alternative compliance through the cap-and-trade program will achieve lower total NO_x emissions from the Group 1 and Group 2 boilers in the state (or group of states) than if the new emission limits remained applicable. Because the CAAA do not permit the administrator to relax existing limits, the existing Group 1 limits, established by the April 13, 1995 regulations, will apply to Group 1 boilers covered by any cap-and-trade program.

This added flexibility is intended to encourage states and utilities involved in the Ozone Transport Assessment Group (OTAG) region, where approximately 87% of the boilers covered by this rule are located, to become involved in a regional cap-and-trade program for NO_x reduction. This provision allows utilities under a cap-and-trade program to reduce NO_x even more cost-effectively than under the current rule. According to EPA, this trading provision provides for coordination of NO_x reduction initiatives under Titles I and IV and is consistent with statutory requirements in a way that promotes the goal of achieving necessary NO_x reductions in a cost-effective manner. General provisions and the applicability, permitting, allowance, excess emissions, monitoring, and opt-in provisions for the NO_x Budget Trading Program are provided in 40 CFR 96 and 40 CFR 97 (Refs. 22 and 23).

4.1.3 New Source Performance Standards

The EPA has established standards of performance for new stationary emission sources, including steam generating units. Emission limits in these standards are generally more stringent than emission limits set for existing facilities already in operation. The NSPS are codified in federal regulations and cover maximum emissions rates and required reductions in potential combustion concentrations for PM, SO₂, and NO_x (expressed as NO₂) emissions. Potential combustion concentration means the theoretical emissions in pounds per million British thermal units heat input that would result from combustion of fuel in an uncleaned state without emission control systems. In this context, new source refers to a unit for which construction or modification commenced after a prescribed date.

The EPA has also established strict emission limitations for new large municipal waste combustion units. In addition to PM, SO₂, and NO_x emission limits, the standard for these units contains emission requirements for a number of other pollutants that are released into the air when certain types of municipal waste are burned.

4.1.3.1 Performance standards for new steam generating units

The NSPS for electric utility steam generating units are provided in 40 CFR 60, Subpart Da (Ref. 24). Both the maximum emissions rate and the required reduction of potential combustion concentration must be met by affected facilities with electric steam generating units that are capable of burning more than 250-MBtu/h heat input of fossil fuels (either alone or in combination with any other fuel) and for which construction or modification began after September 18, 1978. For this regulation, an electric utility steam generating unit means any steam electric generating unit that is constructed for the purpose of supplying more than one-third of its potential electric output capacity and more than 25-MW electrical

output to any utility power distribution system for sale. A summary of NSPS for electric utility steam generating units is provided in Appendix A, Table A.1.

Maximum emissions rates and required reduction of potential combustion concentrations are contained in 40 CFR 60, Subpart Db (Ref. 25) for facilities with ICI steam generating units that are capable of combusting more than 100-MBtu/h heat input and for which construction, modification, or reconstruction began after June 19, 1984. Additional standards are also provided for coal-fired and oil-fired units with heat input capacities between 100 and 250 MBtu/h and certain coal-fired and oil-fired units with heat input capacities greater 250 MBtu/h for which construction, modification, or reconstruction began after June 19, 1984, but on or before June 19, 1986. Standards for ICI steam generating units that conform to these restrictions are summarized in Appendix A, Table A.2.

The NSPS for small ICI steam generating units that are capable of combusting between 10- and 100-MBtu/h heat input and for which construction, modification, or reconstruction began after June 9, 1989, are provided in 40 CFR 60, Subpart Dc (Ref. 26) and summarized in Appendix A, Table A.3. Careful review of this table reveals that there are no emission limits for NO_x emissions. So far, EPA has not promulgated NO_x emission standards for these small units.

In 1998, EPA promulgated a revised NO_x NSPS for new fossil-fuel-fired electric utility and ICI steam generating units.²⁷ The new standards revise the NO_x emission limits for steam generating units covered in 40 CFR Part 60, Subpart Da (Ref. 24) and Subpart Db (Ref. 25) and affect only units for which construction or reconstruction commenced after July 9, 1997. The NO_x emission limit in the final rule for new Subpart Da units is 1.6-lb/MWh gross energy output regardless of fuel type. This change from an input-based format where emissions are linked to the fuel used to an output-based format is intended to promote energy efficiency and NO_x reduction. An output-based format links the emission limit to the amount of electricity generated rather than to the fuel used for combustion.

For existing sources that become subject to Subpart Da through reconstruction, the NO_x emission limit is still expressed in an input-based format of 0.15 lb/MBtu of heat input.²⁴ For new and existing ICI boilers that are subjected to the new source performance standards, EPA lowered the emissions rate to 0.20 lb/MBtu of heat input.²⁵

4.1.3.2 Performance standards for new municipal waste combustion units

The EPA has established NSPS for municipal waste combustion units that are capable of burning greater than 250 tons/day of MSW for which construction commenced after September 20, 1994 or for which modification or reconstruction commenced after June 19, 1996 (Ref. 12). In this standard, MSW means household, commercial, retail, and institutional waste that includes yard waste, RDF, and motor vehicle maintenance materials limited to vehicle batteries and tires. Emissions that are regulated include

- PM,
- cadmium,
- lead,
- mercury,
- SO₂,
- hydrogen chloride,
- dioxin/furan, and
- NO_x.

The maximum allowable emission rates for each of these pollutants are summarized in Appendix A, Table A.4. Specific limits for CO emissions have also been established. However, the maximum allowable CO emission rate varies depending on the technology that is used to burn the municipal waste.

In addition to emission limitations, the regulation also has a requirement for operator certification. Each chief facility operator and shift supervisor must obtain and maintain operator certification from either the ASME²⁸ or a state certification program.

At this time, EPA has not established NSPS for new municipal waste combustion units that are capable of burning 250 tons/day of MSW or less. However, state and local jurisdictions can impose emission limitations on these units provided the requirements are consistent with federal law.

4.1.4 Permitting Requirements

Title V of the CAA includes provisions for issuance of operating permits by the federal government (EPA) as well as state and local jurisdictions. This provision ensures that mandated emissions limitations and emission reduction requirements are achieved in actual practice. Each permit specifies the enforceable requirements that apply to each affected unit or source. In this context, a source is any governmental, institutional, commercial, or industrial structure, installation, plant, building, or facility that emits a regulated air pollutant. Specific definitions of major sources are spelled out in Sects. 112 and 302 of the legislation.

Each permit issued under Title V must include enforceable emission limitations and standards, a schedule of compliance, and a requirement that the permit applicant submit the results of required monitoring to the permitting authority. Other permitting provisions pertain to the certifying of Designated Representatives for affected sources, schedules for submissions, permit processing and revision procedures, and periodic compliance certification reporting. Permits are subject to public comment before approval and are generally available to the public after they are issued.

Regulations that provide for the establishment of comprehensive state and local air quality permitting systems consistent with the requirements of Title V are contained in 40 CFR Parts 70 and 71 (Refs. 10 and 29). Additional regulations that establish certain general provisions and the operating permit program requirements for affected sources and affected units under the Acid Rain Program are contained in 40 CFR Part 72 (Ref. 5). Units affected by this program are identified in 40 CFR 72.6 and 40 CFR Part 74 (Ref. 6). The approval status of the various state and local operating permit programs is summarized in 40 CFR 70, Appendix A.

Other requirements that may influence the permitting process are contained in Title I, Sect. 112 of the CAA, 40 CFR 50 (Ref. 11), 40 CFR 51.165 (Ref. 30), 40 CFR 52.21 (Ref. 31), and 40 CFR 60, Subparts Da, Db, Dc, and Eb (Refs. 24–26, and 12).

Section 112 of CAA lists nearly 200 compounds as HAPs. For facilities that emit, or could emit, HAPs above a certain level, one of the following two requirements must be met.

1. EPA has established standards for specific types of sources. These MACT standards are based on the best demonstrated control technology or practice found on similar sources.
2. For sources where a MACT standard has not been established, the level of control technology required is determined on a case-by-case basis.

Performance standards for new sources are provided in 40 CFR 60, Subparts Da, Db, Dc, and Eb (Refs. 24–26, and 12). They apply to new or modified equipment in a particular industry category. These regulations establish emission limits or work-practice standards for more than 60 categories of sources.

Regulations in 40 CFR 50 (Ref. 11) set maximum permissible levels for six criteria pollutants. These NAAQS are designed to protect public health and the environment from harmful effects of NO_x, SO₂, CO, O₃, PM, and lead emissions. Additional discussions about NAAQS are presented in Sect. 4.1.1. Required emission controls for these pollutants depend on the attainment or nonattainment status of the area where the source is located.

Prevention of Significant Deterioration (PSD) regulations in 40 CFR 52.21 (Ref. 31) allow the installation and operation of large new sources and modification of existing sources in areas that meet the

NAAQS (attainment areas). To assure that the area will continue to meet NAAQS, applicants for construction permits must demonstrate that the BACT is being applied. Requirements for BACT determinations are described in Table 4.4.

A permit to construct and operate a new or modified major source anywhere in an area that does not meet NAAQS (NAAs) cannot be issued unless the source is required to comply with the LAER as defined in 40 CFR 51.165 (Ref. 30). The meaning of LAER is discussed in Table 4.4.

Table 4.4. BACT and LAER applicability and requirements

BACT
<p>BACT: Best Available Control Technology</p> <p>Applicability: BACT is applicable to new boilers located in attainment areas. These areas are in compliance with NAAQS.^a</p> <p>Requirements: By law, BACT determinations must consider the economic, environmental, and energy impacts of each installation on a case-by-case basis. To satisfy this requirement, a permit applicant must identify all air pollution control options available, the feasibility of applying these options, the effectiveness of each option, and why the option proposed in the application represents BACT. The accepted method for performing these assessments is known as top-down BACT. Implementing top-down BACT requires an assessment of emission control technologies beginning with the technique that is the most effective. If this technique is cost-effective and technically feasible, then it must be applied. However, if the cost is too high or its application is not feasible, the next most effective technique must be assessed until an acceptable technique is identified.</p>
LAER
<p>LAER: Lowest Achievable Emissions Rate</p> <p>Applicability: LAER is applicable to new boilers located in NAAs. These areas are not in compliance with NAAQS.^a</p> <p>Requirements: LAER means the more stringent rate of emissions based on the following:</p> <ul style="list-style-type: none">• The most stringent emissions limitation that is contained in the implementation plan of any state for such class or category of stationary source, unless the owner or operator of the proposed stationary source demonstrates that such limitations are not achievable; or• The most stringent emissions limitation that is achieved in practice by such class or category of stationary sources. This limitation, when applied to a modification, means the LAER for the new or modified emissions units within a stationary source. Under no conditions does the application of the term permit a proposed new or modified stationary source to emit any pollutant in excess of the amount allowable under an applicable new source standard of performance. <p>LAER is the most stringent of all technology-based regulations and is different from BACT. The cost-effectiveness of applying a particular emission control technique cannot be considered in LAER determinations. When required, technology equivalent to LAER must be used regardless of the cost.</p>

^aConsult 40 CFR 50 for NAAQS details (Ref. 11).

Permits issued to sources located in NAAs are called Nonattainment New Source Review Permits. To receive one of these permits, emissions offsets must be obtained. An offset is a method used in the CAA to give companies that own or operate large (major) sources in NAAs flexibility in meeting overall pollution reduction requirements when changing production processes. These offsets represent reductions in actual emissions from some other source. This source may be at the same plant or at another plant owned by the applicant or from some other company with a source that is located within the NAA. In

actual practice, permit applicants must obtain an offset that is somewhat greater than the amount of pollution they will emit. This ensures that permit requirements are met and the NAA keeps moving toward attainment. The permit applicant must also install pollution control equipment to significantly reduce emissions. Trading offsets are allowed because total pollution levels will continue to decrease using this approach.

4.1.4.1 Acid Rain Program Permits

Affected and unaffected steam generating units subject to Acid Rain Program requirements are identified in 40 CFR 72 (Ref. 5). Units that are part of Phase I or Phase II make up the bulk of the affected units. Although most emission sources affected by the Acid Rain Program must have an Acid Rain Permit, two types of affected utility units that are not required to be covered by an Acid Rain Permit are small new units burning clean fuels and retired units. These units are automatically exempted from the requirement to be covered by an Acid Rain Permit. However, an exemption notice must be submitted to the permitting authority and EPA headquarters.

During Phases I and II of the Acid Rain Program, affected sources are required to apply for two Acid Rain Permits. They include Acid Rain Permits issued by EPA during Phase I, and either the acid rain portion of an operating permit issued by a state permitting authority during Phase II or the acid rain portion of an operating permit issued by EPA when it is the permitting authority during Phase II. Requirements for Acid Rain Permits supplement, and in some cases modify, the state permitting requirements contained in 40 CFR Part 70 (Ref. 10).

Owners and operators of each source must select one person to represent them in matters pertaining to the Acid Rain Program. A second person may be selected to act as an alternate for the first. These people are known as the Designated Representative and Alternate Designated Representative, respectively. Both people must be identified in a Certificate of Representation, submitted to EPA headquarters, as having been selected by an agreement binding on the owners and operators of a source.

The Designated Representative is responsible for submitting to EPA and permitting authorities all Acid Rain Program submissions for the source, including allowance transfers, emission monitoring reports, compliance certifications, Excess Emissions Offset Plans, permit applications, and permit revisions. The Designated Representative must sign and attest to the truth and accuracy of each submission. Permits are only issued to a source if EPA has received a Certificate of Representation for the designated representative. The owner or operator of a source may change the Designated Representative at any time by submitting a revised Certificate of Representation to EPA.

Four types of Acid Rain Permit revision procedures are available: permit modifications, fast-track permit modifications, administrative permit amendments, and automatic permit amendments.

1. Permit modification procedures apply to, among other things, the inclusion of compliance plans in the Acid Rain Permit that were not included when the permit was issued. Permit modifications involve the same public notice and comment procedures as those involved in the issuance of a permit.
2. The fast-track modification may be used, at the option of the Designated Representative, for incorporation of new compliance options, as well. With fast-track modifications, the permit applicant gives notice of the proposed permit modification in a newspaper near the area where the source is located and gives notice to interested parties. The public has 30 d to comment. The permit applicant submits its proposed modification to the permitting authority, which has 90 d after the close of the comment period to act on the proposed modification.
3. The administrative permit amendments procedure applies to simple alterations to an Acid Rain Permit such as corrections of typographical errors and name and address changes. Administrative amendments are made by the permitting authority without public notice.

4. An automatic permit amendment occurs whenever EPA records an emissions allowance transaction in the Allowance Tracking System. An Acid Rain Permit is deemed to automatically include these amendments.

For units that emit SO₂ and become affected units under the Acid Rain Program through participation in the Opt-in Program, an Opt-in Permit is required based on permitting procedures in 40 CFR 74, Subpart B (Ref. 6).

The deadline for submitting Acid Rain Permit applications for all Phase I units was February 15, 1993. EPA issued permits for these units. Permit applications for all Phase II units were due to an EPA-approved state or local permitting authority on January 1, 1996. Acid Rain Permits are effective for a 5-year period. After this time, the permit must be reissued. Six months prior to expiration, a complete Acid Rain Permit application must be submitted to the appropriate state or local permitting authority. A complete Acid Rain Permit application must include the following:

- identification of the affected source,
- identification of the Phase I or Phase II unit or units for which the permit application is being submitted,
- a complete compliance plan for the unit in accordance with requirements in 40 CFR 72, Subpart D (Ref. 5),
- the date the unit commenced or will commence operation and the deadline for monitor certification if the unit is for Phase II and it is a new unit, and
- certification of familiarity with applicable standard requirements.

Each affected source must have a compliance plan covering each affected unit. A compliance plan is a written document that describes the actions that will be taken to ensure compliance with the Acid Rain Program. At a minimum, the plan must indicate that the unit will hold enough allowances to cover its annual SO₂ emissions and will be operated in compliance with the applicable NO_x emission limitations.

Compliance plans must be properly cross-referenced in the Acid Rain Permit for each source and signed by each Designated Representative. Multiunit compliance options involving separate sources may have different Designated Representatives. The plan may also include options for compliance with SO₂ and NO_x emission limitations. These options are typically described in either separate SO₂ or NO_x compliance plans that reflect a particular strategy such as those described in Tables 4.5 and 4.6.

4.1.4.2 State Operating Permit Programs

In preparing the CAAA, it was generally recognized that states should be responsible for taking the lead in carrying out the requirements in the law, because pollution control problems often require special understanding of local industries, geography, demographics, and ecosystems. States are required to develop SIPs that explain how each state will perform its duties under the law. A SIP is a collection of the regulations that a state will use to clean up polluted areas. During SIP development, states must involve the public through hearings and opportunities to comment. EPA must also approve the SIP. If a SIP is unacceptable, EPA can take over enforcing the CAA in that state. Nothing in the federal regulations prevents a state from establishing more stringent requirements provided that the requirements are consistent with the federal law.

All states are required to develop and implement an operating permit program that meets minimum federal requirements. Authorization for the operating permit program is provided in Title V, Sects. 501 to 506 of the CAA. Regulations for implementing the operating permit requirements were promulgated on July 21, 1992, and are located in 40 CFR Part 70 (Ref. 10). Permits are required both for the operation of

Table 4.5. Compliance options for SO₂ emissions

SO₂ compliance option	Description
Phase I Substitution Plan	A Phase I unit may reassign all or some of its Phase I SO ₂ emissions reduction requirements to one or more existing units (called substitution units) that would otherwise not be regulated until Phase II. The Phase I unit remains subject to all Phase I requirements, and the substitution unit becomes a Phase I unit, is allocated allowances, and must meet all Phase I requirements. Substitution units involved in a Substitution Plan must be under the control of the owner or operator of the Phase I unit.
Phase I Extension Plan	By February 22, 1993, a Phase I unit, and any unit that would become affected in Phase I under another compliance option, could have applied for a 2-year extension of its Phase I SO ₂ limitations. Extensions were granted to units that would (1) use a qualifying technology that could be shown to remove at least 90% of a unit's SO ₂ emissions, or (2) reassign emissions reduction obligations to another unit that would use such a technology during Phase I. A unit receiving such an extension of its Phase I SO ₂ emissions limitations also obtained a similar extension for its Phase I NO _x limitations. A Phase I extension unit was given extra SO ₂ emissions allowances to cover the SO ₂ that it emits beyond its basic Phase I allocation during 1995 and 1996. A limit of 3.5 million allowances was available to these units.
Phase I Reduced Utilization Plan	<p>A Phase I unit may meet its SO₂ emissions reduction requirements by reducing electricity generation. The unit can compensate for planned reduced output by (1) designating one or more Phase II SO₂-emitting units (called compensating units) to increase generation, (2) adopting verifiable energy conservation or improved unit efficiency measures, or (3) designating sulfur-free generators to provide increased generation. EPA grants allowances to compensating units based on their 1985 SO₂ emissions rates and their baselines (i.e., average annual fuel use from 1985 to 1987). Like a substitution unit, a compensating unit becomes a Phase I unit and must meet all Phase I requirements.</p> <p>Because both the original and compensating units must hold enough allowances to cover SO₂ emissions, allowances may be transferred from the original unit to the compensating units to cover emissions beyond their allocated allowances. The units in a Reduced Utilization Plan are not required to have a common owner or operator with the original unit. If reduced utilization is not accounted for by a compensating unit, conservation, improved unit efficiency, or sulfur-free generation, the unit reducing utilization may have to surrender allowances.</p>
Phase II Repowering Extension	<p>Phase II units may obtain a 4-year extension of the Phase II emissions reduction deadline if they repower with a qualified repowering technology. Repowering requires replacement of an existing coal-fired boiler with (1) one of seven technologies listed in the CAA, (2) a derivative of one of those technologies, or (3) a technology determined by EPA and the DOE to control multiple combustion emissions and improve boiler or generation efficiency while significantly reducing waste as compared to technology commonly used in 1990.</p> <p>Qualified technologies are atmospheric or pressurized FBC, integrated gasification combined cycles, magnetohydrodynamics, direct and indirect coal-fired turbines, and integrated gasification fuel cells. To obtain a Repowering Extension, a Designated Representative must petition EPA for conditional approval of the technology. If a unit proceeds with repowering that later proves infeasible, it will not be held liable for failing to repower as long as it acted in good faith.</p>

Table 4.6. Compliance options for NO_x emissions

NO _x compliance option	Description
Standard emission limitations	A utility operator can choose to meet the standard annual emission limitation of 0.50 lb/MBtu of NO _x for dry bottom wall-fired boilers, or 0.45 lb/MBtu of NO _x for tangentially fired boilers. The CAA requires EPA by January 1, 1997, to determine whether these limitations should be made more stringent for Phase II and to set limitations for other types of coal-fired utility boilers.
Emissions averaging	A utility can meet the standard emission limitations by averaging the emissions of two or more boilers with the same owner or operator. This approach allows utilities to over-control at units where it is technically easier or less expensive to control emissions, thereby achieving emissions reductions at lower cost.
Alternative emission limitations	When a utility cannot meet the standard emission limit using LNB technology, it can qualify for a less stringent AEL if it uses LNB technology designed to meet that limit. LNB technology excludes combustion air staging approaches that require new holes located outside any boiler opening that includes a burner (i.e., OFA for wall-fired boilers or separated OFA for tangentially fired boilers). EPA's determination of an AEL is based on evidence that control equipment was properly designed, installed, and operated during a demonstration period.
Phase I extensions	Utilities with Group 1 boilers were able to ask for a 15-month extension of the compliance deadline to March 31, 1996. Utilities demonstrated that LNB technology designed to meet the applicable limitation could not be installed and operated at six units by January 1, 1995, without adverse impacts on the reliability of the utility's dispatch of electricity to its customers. EPA granted extensions for these units.
Early election	A Phase II affected unit with a Group 1 boiler that complies with the appropriate Phase I NO _x emission limit by January 1, 1997, will be exempt from any revision of the Group 1 emission limitation for Phase II until 2008. These units cannot average their emissions until 2000, and then they must average using the applicable Phase II limit (which may be more stringent than the Phase I limit). By encouraging affected sources to comply early with the Phase I limits, emission reductions are achieved early, and the utilities can ensure themselves of greater certainty in their long-range planning and electric grid system reliability.

units (operating permits) and for the construction of new units. State governments benefit from the operating permit program in several ways:

- The operating permit program provides a mechanism that state and local agencies can use to consolidate and administer provisions of the CAA, as well as their own laws.
- The program provides all state and local permitting agencies with the authority to sustain their operations using direct permit fees rather than general tax revenues.
- Improved industrial compliance with emission standards is expected to help state and local governments meet NAAQS and possibly even avoid additional local emission controls.

State or local permitting authorities administer acid rain permitting programs under both Titles IV and V of the CAA. States process Acid Rain Permit applications, issue draft Acid Rain Permits for public comment, and submit proposed Acid Rain Permits to EPA for review. The permitting authorities then issue Acid Rain Permits that are approved. Each Acid Rain Permit specifies the Title IV requirements that apply to the affected source and is a portion of a larger Title V permit.

An Acid Rain Permit specifies each unit's allowance allocation and NO_x emission limitations (if applicable), and also specifies compliance plan(s) for the affected source. The following schedule presents due dates for Acid Rain Permit applications.

- Initial Acid Rain Permit applications were due by January 1, 1996.
- Initial NO_x compliance plans were due by January 1, 1998.
- Acid Rain Permit applications for new units are due 24 months before the unit commences operation.
- Renewal Acid Rain Permit applications and NO_x compliance plans are submitted to the permitting authority at the same time as the associated Title V permit renewal applications.

Since 1992, EPA has approved permit programs for all 113 state, territorial, and local permitting authorities in the nation. EPA is also working with tribal governments to develop tribal permit programs. In the next few years, EPA expects several tribes to submit program plans for approval.

As of January 1998, state and local permitting authorities received nearly 14,000 applications for operating permits. This represents more than 60% of the estimated 22,000 sources subject to the program nationwide. State and local permitting authorities have issued nearly 3,000 Title V operating permits and hundreds of draft permits. In addition, several thousand companies that would otherwise qualify as major sources have agreed to comply with emission standards by maintaining operations below levels that trigger the need for an operating permit.

4.2 INFORMATION SOURCES

Because the CAA is a federal law administered by both EPA and various state and local government agencies, these groups are authoritative sources of information about emission standards and compliance issues. The EPA headquarters is located at 1200 Pennsylvania Avenue in Washington, D.C. Ten EPA regional offices and numerous other satellite offices and laboratories are located throughout the United States.

Information for contacting EPA staff is readily available using a computer by accessing the World Wide Web (<http://www.epa.gov>). Links at this site can also be used to locate offices of the various state environmental protection agencies. Although it is possible to interface directly with individual staff members of these agencies, valuable documentation about emission standards and compliance issues is electronically available. Pertinent information about air pollution issues can be found on the EPA web site as well as web sites maintained by state and local agencies.

The EPA home page includes direct links to various sources of information such as the library system, information centers, clearinghouses, publications, newsletters, test methods, and databases. One of the most useful links on the home page makes it possible to view text of the CAA, the CAAA, and regulations issued by EPA under Title 40 of the *Code of Federal Regulations*. There is even a page that presents *The Plain English Guide to the CAA*.³² The EPA Web site also contains a separate area dedicated to air projects and programs. Pages linked to this site contain information describing EPA's position on its Acid Rain Program.

To facilitate transfer of technical information, EPA has established the Technology Transfer Network (TTN). This network is a collection of technical World Wide Web sites (<http://www.epa.gov/ttn>) that contain information about many areas of air pollution science, technology, regulation, measurement, and prevention. In addition, the TTN serves as a public forum for the exchange of technical information and ideas among participants and EPA staff.³³ Some TTN pages may be useful in selecting low-emission boilers and combustion equipment:

- The Air Toxics Web (ATW) site focuses on EPA's efforts to reduce routing emissions from stationary sources.
- The Clean Air Technology Center (CATC) serves as a resource for all areas of emerging and existing air pollution prevention and control technologies and provides public access to data and information

on their use, effectiveness, and cost. CATC includes the RACT/BACT/LAER Clearinghouse (RBLC).

- The ClearingHouse for Inventories and Emission Factors (CHIEF) contains information on emission inventories and emission factors. It also provides access to tools for estimating emissions of air pollutants and developing air emission inventories.
- The Emission Measurement Center (EMC) provides access to emission test methods and testing information for the development and enforcement of national, state, and local emission prevention and control programs.
- The New Source Review (NSR) Web site is designed to provide material and information pertaining to NSR permitting.
- The OAR Policy and Guidance (OAR P&G) Web site is designed to provide access to rules, policy, and guidance documents produced by the EPA Office of Air and Radiation (OAR).
- The Support Center for Regulatory Air Models (SCRAM) is a source of information on atmospheric dispersion (air quality) models that support regulatory programs required by the CAA.

The EPA has also established a series of public information centers where relevant information on regulations can be accessed via the World Wide Web. The information resources center at Region 7 is particularly useful. It includes electronically accessible databases dealing with policy and guidance documents for Title V operating permits, NSR topics, and PSD issues. These databases contain documents issued by EPA's headquarters and regions, and the database management systems allow the user to search the contents of the documents.

Another valuable source of information available from EPA is contained in its national publications catalog.³⁴ This hardcopy volume describes the numbering system identification codes used by EPA to designate publications and includes a complete list of EPA publications in numerical order. General information about EPA and its regions is also provided.

World Wide Web sites for the various state and local government environmental protection organizations, such as California's Environmental Protection Agency, the Air Resources Board (<http://www.arb.ca.gov/homepage.htm>) and Michigan's Department of Environmental Quality, Air Quality Division (<http://www.deq.state.mi.us/aqd>), also contain useful information. By using this method of accessing information, it is possible to view pages that address state regulations, establish the basis for air quality programs, present permit application guidance, provide draft permits for public review and comment, and include completed permits issued for construction or operation. Review of these permits can sometimes be helpful in selecting emission control equipment that will reduce emissions to levels that are acceptable to the permitting authority.

In 1967, an interstate association of air quality divisions was formed to exchange technical information and to promote cooperation and coordination of air pollution control issues. This association, known as the Northeast States for Coordinated Air Use Management (NESCAUM), includes the states of Connecticut, Maine, Massachusetts, New Hampshire, New Jersey, New York, Rhode Island, and Vermont. To accomplish its objectives, NESCAUM sponsors air quality training programs, participates in national debates, and promotes a variety of research initiatives. Their World Wide Web site (<http://www.nescaum.org>) provides information about their activities and includes a list of their publications. One document in this list that may be particularly useful is titled *NESCAUM BACT Guideline*.³⁵ Although published in 1991, this document (<http://www.nescaum.org/archive.html>) focuses on the types of data required in a preconstruction permitting application and how the data should be used in determining BACT.

4.3 PERMITTING BASICS

The permit program established under Title V of the CAA provides a means for federal, state, tribal, and local authorities to regulate air pollution by consolidating all air pollution control requirements into a

single, comprehensive operating permit that covers all aspects of a source’s year-to-year air pollution activities. For the past several years, EPA has worked with state and local governments to establish operating permit programs in every state, including 60 local programs, as well as programs in the District of Columbia and other territories. Operating permits are comprehensive regulatory documents used to ensure that source operators know what air pollution control requirements apply.

Although the general procedure for obtaining construction and operating permits is now well-established, obtaining a permit is often time-consuming and technically complex. Extensive knowledge of the boiler and emission control equipment; an understanding of applicable local, state, and federal laws; and a willingness to work with permitting authorities are essential.

More than 100 state and local permitting authorities, including EPA, are involved in issuing permits. They each have their own set of steps required for the permitting process. Because of this complexity, only general guidance for obtaining a permit can be provided. Table 4.7 presents some of the more important steps involved in obtaining permits for new air pollution sources.^{36,37}

The first step in any permitting process involves determining whether a permit is required. If a permit is required, it is then important to identify the type of permit that is appropriate. This determination may require a significant level of time and effort by the owner or operator and may involve discussions with legal council, environmental consultants, and regulatory authorities.

In general, all major stationary sources (primarily industrial facilities and large commercial operations) that emit certain air pollutants are required to obtain operating permits. Whether a source meets the definition of major depends on the type and amount of air pollutants that it emits and, to some

Table 4.7. General guidance for obtaining a permit for a new air pollution source^a

Permitting activity	Description
During the initial planning stages of a new installation or emissions source	<p>Assemble background information, collect resources, and review applicable local, state, and federal air-quality laws and regulations with particular emphasis on the following:</p> <p>CAA and CAAA</p> <ul style="list-style-type: none"> • Title I—Air Pollution Prevention and Control • Title III—Air Toxics • Title IV—Acid Deposition and Control • Title V—Permits <p>40 CFR Subpart C</p> <p>Part 50—National Primary and Secondary Ambient Air Quality Standards Part 51, Paragraph 51.165—Permit Requirements Part 52, Paragraph 52.21—Prevention of Significant Deterioration of Air Quality Part 60—Standards of Performance for New Stationary Sources Part 61—National Emissions Standards for Hazardous Air Pollutants Part 63—National Emissions Standards for Hazardous Air Pollutants for Source Categories Part 70—State Operating Permit Programs Part 71—Federal Operating Permit Programs Part 72—Permits Regulation Part 73— Sulfur Dioxide Allowance System Part 74— Sulfur Dioxide Opt-Ins Part 75—Continuous Emissions Monitoring Part 76—Acid Rain Nitrogen Oxides Emission Reduction Program Part 96— NO_x Budget Trading Program for State Implementation Plans Part 97—Federal NO_x Budget Trading Program</p> <p>Determine whether the installation or source is located in a nonattainment region. If so, identify which of the six criteria pollutants do not meet NAAQS.</p>

Table 4.7. (continued)

Permitting activity	Description
During engineering design	Contact the regulatory authority having jurisdiction to discuss the proposed source and whether a permit is required. If a permit is required, discuss permitting, permit fees, permit-processing time, application forms, air-monitoring requirements, emissions-testing requirements, proposed regulations, emissions requirements, permit limitations, and any other details unique to the proposed installation. To provide design flexibility, discuss technical options and operating alternatives for emissions control. Consideration of these options and alternatives may be required as part of the BACT or LAER assessment process. Complete the required applications for a Permit to Install and finalize any necessary supporting documentation. Before submitting the application, contact the regulatory authority having jurisdiction and confirm that the data that you plan to submit are sufficient. Verify that the Designated Authority has signed the application, and then submit the application and supporting documentation.
After regulatory authority receives the completed construction permit application	The local or regional office reviews the application, determines if the installation and proposed emissions control technology complies with applicable regulations, and develops any necessary terms and conditions. If additional information is needed, the owner or operator is contacted.
After the construction permit application is submitted	The local or regional office sends a recommendation to the state EPA's central office (the central office). The central office performs a technical review. If approved, the central office issues a draft or final Permit to Install. If not approved, the application is sent back to the local office.
During the construction permit application review and public comment period	For large sources and certain types of sources, the local or regional office will issue a draft permit and place a notice in the local newspaper detailing the proposed installation and soliciting public comment within 30 days. A public meeting may be held. If no comments are received, the process proceeds. Otherwise, the permit may require modification or be denied.
After approval for construction is obtained from the regulatory authority having jurisdiction	The central office issues a final Permit to Install. It allows the company to begin construction and operate the facility for the purpose of emission testing.
During construction	Build, install, and test the installation. Send an application for a Permit to Operate to the authority having jurisdiction.
After the operating permit application is submitted	The local office makes a technical review and develops terms and conditions. The central office performs a technical review. If all is well, a Permit to Operate is issued for a prescribed time period (up to 5 years).
During operation	The owner or operator must comply with the terms and conditions in the permit, which may involve emission reporting. If operations change, the permit may need to be revised. Public notification is required when permits are significantly revised.
Before the operating permit expires	Contact the regulatory authority having jurisdiction, and begin the process of renewing the operating permit.

^aSource: Refs. 36 and 37.

degree, on the overall air quality in the vicinity. Generally, major sources include those stationary facilities that emit 100 tons or more per year of a regulated air pollutant. Regulated pollutants include compounds such as CO, PM, VOCs, SO₂, and NO_x. Smaller sources are considered major in areas that are

not meeting the national air quality standards for a particular pollutant. For example, certain sources releasing 25 or even 10 tons of pollutant emissions per year are considered major in areas with extreme ozone problems. The operating permit program also covers a variety of other significant operations:

- large coal-burning utility boilers and industrial boilers subject to control requirements under the acid rain provisions of the CAA,
- sources that are subject to requirements under NSPS and National Emission Standards for Hazardous Air Pollutants (NESHAPs),
- sources of toxic air pollutants (i.e., any source that emits more than 10 tons/year of an individual toxic air pollutant or more than 25 tons/year of any combination of toxic air pollutants), and
- sources required to have preconstruction or new source permits under NSR or PSD requirements.

In this context, a source is often a very large facility with a wide variety of processing operations and hundreds of individual emission sources, including combustion boilers. Examples include chemical plants, petroleum refineries, and large manufacturing facilities. In cases where multiple emissions sources are involved, the permitting process can be technically complicated.

After the need for a permit has been established, it is generally recognized that many factors can impact a permit application. Some of the more important factors that may be applicable include the following:

- capacity of a new boiler, including its design features, fuel consumption, and emission control equipment;
- type and extent of modifications to existing boiler or combustion equipment;
- time of year and length of time boiler is in operation;
- methods used to control the boiler and emission control equipment during startup, shutdown, and continuous operation;
- anticipated changes in equipment or operations during the permit period;
- maintenance procedures and schedules;
- location of boiler (Is it in an attainment or nonattainment region?);
- type and amount of each regulated pollutant emitted;
- emissions rates from other sources at the site or in the vicinity;
- terms and conditions of permits previously issued to the owner or operator;
- terms and conditions of permits previously issued to other emission sources by the same permitting authority;
- data and supporting documentation required by the permitting authority;
- environmental impact requirements, including concerns of affected Federal Land Managers;
- applicability of NSPS and PSD requirements;
- Continuous Emissions Monitoring (CEM) requirements;
- BACT assessments;
- LAER determinations; and
- emission offsets, allowances, and credits.

Other key provisions of the operating permit program are as follows:

- Sources are required to provide emissions reports to their permitting authorities at least semiannually and must certify their compliance status annually.
- Sources must periodically renew their operating permit, generally every 5 years.
- To fund their programs, permitting authorities are required to collect permit fees from sources subject to the operating permit program. Fees are most frequently based on the amount of air pollutants that a source may emit.

- Public notification and opportunity for comment must be provided during the permit review process for every new permit and when permits are renewed or significantly revised.
- EPA is responsible for overseeing the implementation of permit programs and may object to a permit that fails to comply with program requirements.
- EPA is also required to establish a federal permit program in any area where the permitting authority fails to develop and maintain an adequate program of its own.

Note that state and local governments can and do implement separate requirements that are appropriate for their unique local conditions and system of laws. However, these requirements can be more stringent than those of the federal government.

Although permitting programs are administered by separate governmental agencies, the permitting process reduces the waste and confusion inherent in redundant and contradictory requirements issued by state, local, and federal authorities. As established, the operating permit program can make it easier to incorporate flexible approaches to operations and to foster use of market-based emissions trading programs as a compliance tool. This reduces the burden of time-consuming permit amendments for facilities needing to make changes quickly or wishing to make emissions allowance trades.³⁶ The operating permit program provides a uniform and efficient mechanism that state and local agencies can use to consolidate and administer provisions of the CAA as well as their own laws.

4.4 LESSONS LEARNED

More than 15,000 permit applications for major sources have been submitted to local, state, and federal permitting authorities to comply with application laws and regulations.³⁸ Through this process, it is apparent to owners, operators, and regulators that the best time to control pollution is at the time the source is installed or modified. This means that new units should use the best emissions control technology that is available, and modifications to existing units should result in reduced emissions to achieve NAAQS mandated by the CAA. For successful permitting, it is important to follow these guidelines:

- Visit the permitting authority at an early stage in the planning process to identify contacts and establish lines of communications.
- Determine what permits are required and which forms must be completed by talking to the regulatory authority.
- Cooperate with permitting authorities. Cooperation is the key to a permitting process that meets all requirements and satisfies the needs of owners, operators, regulators, and the public.
- Know the project details and technical plans so that visits to the permitting authority are as productive as possible. Do not hide design details.
- Keep discussions with regulators technical in nature. Do not let personalities interfere with negotiations.
- Anticipate emissions as accurately as possible and then request emission levels that include a margin of safety.
- Know when and how to ask for help interpreting laws and regulations that appear to be confusing or conflicting.
- Be honest, accurate, and complete when asking questions, submitting applications, and reporting emissions data to regulatory authorities.
- Recognize that local and state regulatory authorities may be understaffed for the existing workload and that obtaining a permit may be a long, tedious, and iterative technical process.
- Review permits previously issued by the regulatory authority for other facilities with similar design and emission requirements. Understanding the terms and conditions of these permits and being aware of the basis on which permitting decisions were made can help in the development of a permitting strategy that will be successful.

- Perform realistic cost estimates, and conduct meaningful cost-benefit analyses.
- Involve attorneys in technical discussions with the regulatory authority only when necessary. Their presence may hinder or impede the exchange of communication about technical issues.
- Recognize that the permitting authority has wide interpretive latitude. Present feasible, technical options for reducing emissions when proposed plans are unacceptable.
- Track the permitting process. Do not turn the permitting process over to a third party and then assume negotiations will proceed smoothly and without delay.
- Establish clear exits from a project when it is apparent that the permitting process will not be successful.
- Formulate a plan with the regulatory authorities, and stay focused on achieving the required milestones.
- Be open and objective with regulators and the public. Do not withhold information or be confrontational.
- Understand the position of the regulatory authority, and only focus on issues that pertain to the permitting process.
- Negotiate permit terms and conditions. Reserve appeals for situations that are considered totally unacceptable or unrealistic.
- Persevere, but do not allow time to pass without action. Time wasted due to delays is usually not recovered.

The permitting process can provide benefits to owners and operators by resolving questions about which local, state, and federal requirements do and do not apply. It can also enable owners and operators to fully understand their compliance obligations and assure that the permit covers all legal requirements contained in the CAA. Compliance with emission standards is expected to help state and local governments meet NAAQS and possibly even avoid additional local emission controls.

4.5 REFERENCES

1. *The Clean Air Amendments Act: Updated Strategies*, TRC Environmental Corporation, Windsor, Connecticut, and Hale and Door, Washington, D.C., 1994.
2. "Clean Air Act," U.S. Environmental Protection Agency, <http://www.epa.gov/oar/caa/contents.html>
3. "The Clean Air Act Amendments of 1990 Overview," U.S. Environmental Protection Agency, <http://www.epa.gov/oar/caa/overview.txt>
4. M. J. Krolewski and A. S. Mingst, "Recent NO_x Reduction Efforts: An Overview," ICAC Forum 2000, U.S. Environmental Protection Agency.
5. "Permits Regulation," 40 CFR 72, U.S. Environmental Protection Agency.
6. "Sulfur Dioxide Opt-Ins," 40 CFR 74, U.S. Environmental Protection Agency.
7. "Continuous Emissions Monitoring," 40 CFR 75, U.S. Environmental Protection Agency.
8. "Excess Emissions," 40 CFR 77, U.S. Environmental Protection Agency.
9. "Appeal Procedures for Acid Rain Program," 40 CFR 78, U.S. Environmental Protection Agency.
10. "State Operating Permit Programs," 40 CFR 70, U.S. Environmental Protection Agency.
11. "Primary and Secondary National Ambient Air Quality Standards," 40 CFR 50, U.S. Environmental Protection Agency.
12. "Standards of Performance for Large Municipal Waste Combustors for Which Construction is Commenced After September 20, 1994, or for Which Modification or Reconstruction is Commenced After June 19, 1996," 40 CFR 60, Eb, U.S. Environmental Protection Agency.
13. *Final Revisions to the Ozone and Particulate Matter Air Quality Standards*, EPA-456/F-97-004, U.S. Environmental Protection Agency, July 1997.

14. *RACT/BACT/LAER Clearinghouse Clean Air Technology Center Annual Report for 1999, A Compilation of Control Technology Determinations Ninth Supplement to 1999 Edition*, EPA 456/R-99-004, U.S. Environmental Protection Agency, June 1999.
15. “Finding of Significant Contribution and Rulemaking for Certain States in the Ozone Transport Assessment Group Region for Purposes of Reducing Regional Transport of Ozone; Rule,” *Federal Register*, **63**, No. 207, 57355-57404, October 27, 1998.
16. “Technical Amendment to the Finding of Significant Contribution and Rulemaking for Certain States in the Ozone Transport Assessment Group Region for Purposes of Reducing Regional Transport of Ozone,” *Federal Register*, **65**, No. 42, 11222–11231, March 2, 2000.
17. “Findings of Significant Contribution and Rulemaking on Section 126 Petitions for Purposes of Reducing Interstate Ozone Transport; Final Rule,” *Federal Register*, **64**, No. 100, 28249-28328, May 25, 1999.
18. “Findings of Significant Contribution and Rulemaking on Section 126 Petitions for Purposes of Reducing Interstate Ozone Transport,” *Federal Register*, **65**, No. 11, 2654-2703 January 18, 2000.
19. “Sulfur Dioxide Allowance System,” 40 CFR 73, U.S. Environmental Protection Agency.
20. “Acid Rain Nitrogen Oxides Emission Reduction Program,” 40 CFR 76, U.S. Environmental Protection Agency.
21. “Acid Rain Program, Nitrogen Oxides Emission Reduction Program; Final Rule,” *Federal Register*, **61**, No. 245, 67111-67164, December 19, 1996.
22. “NO_x Budget Trading Program for State Implementation Plans,” 40 CFR 96, U.S. Environmental Protection Agency.
23. “Federal NO_x Budget Trading Program,” 40 CFR 97, U.S. Environmental Protection Agency.
24. “Standards of Performance for Electric Utility Steam Generating Units for Which Construction is Commenced After September 18, 1978,” 40 CFR 60, Da, U.S. Environmental Protection Agency.
25. “Standards of Performance for Industrial-Commercial-Institutional Steam Generating Units,” 40 CFR 60, Db, U.S. Environmental Protection Agency.
26. “Standards of Performance for Small Industrial-Commercial-Institutional Steam Generating Units,” 40 CFR 60, Dc, U.S. Environmental Protection Agency.
27. “Revision of Standards of Performance for Nitrogen Oxide Emissions From New Fossil-Fuel Fired Steam Generating Units; Revisions to Reporting Requirements for Standards of Performance for New Fossil-Fuel Fired Steam Generating Units,” *Federal Register*, **63**, No. 179, 49442-49455, September 16, 1998.
28. “Standard for the Qualification and Certification of Resource Recovery Facility Operators,” ASME QRO-1-1994, The American Society of Mechanical Engineers, New York.
29. “Federal Operating Permit Programs,” 40 CFR 71, U.S. Environmental Protection Agency.
30. “Permit Requirements,” 40 CFR 51.165, U.S. Environmental Protection Agency.
31. “Prevention of Significant Deterioration of Air Quality,” 40 CFR 52.21, U.S. Environmental Protection Agency.
32. *The Plain English Guide to the Clean Air Act*, EPA-400-K-93-001, U.S. Environmental Protection Agency, April 1993.
33. *Technology Transfer Network Web*, EPA-456/F-98-003, U.S. Environmental Protection Agency, July 1998.
34. *EPA National Publications Catalog*, EPA 200-B-00-001, U.S. Environmental Protection Agency, July 2000.
35. *NESCAUM BACT Guideline*, Document No. SS-8, Northeast States for Coordinated Air Management, Boston, Massachusetts, June 1991. <http://www.nescaum.org/archive.html>
36. *Air Pollution Operating Permit Program Update, Key Features and Benefits*, EPA/451/K-98/002, U.S. Environmental Protection Agency, February 1998.
37. F. A. Govan, *Permitting Requirements for Industrial, Commercial, and Institutional Boilers*, Pendent Media, Inc., Cleveland, Ohio, November 2000.

38. M. R. Barr, "What 15,000+ Permits and Permit Modifications Have Taught Us," presented at the CIBO NO_x Control XIV Conference, San Diego, California, March 13, 2001.

5. EMISSION CONTROL TECHNIQUES

Controlling NO_x, SO₂, CO, and PM emissions from ICI boilers is often necessary to comply with environmental regulations. Techniques that are effective in reducing or eliminating these emissions can be subdivided into three general categories depending on which stage in the combustion process they are applied. The categories include precombustion, combustion, and postcombustion emission control techniques.

When coal is washed or crude oil is refined, sulfur-laden particles and ash-bearing materials are removed, thereby making the fuel more desirable for applications where lower emissions are required. These fuel processing methods are very effective precombustion emission control techniques. Controlling the amount of NO_x and SO₂ that form during combustion is also an effective technique for reducing emissions. Although fuel processing and combustion controls play significant roles in emissions reduction, sometimes it is necessary to use postcombustion emission control techniques to remove NO_x, SO₂, and PM from the flue gas. Commonly used techniques for processing fuel, controlling the combustion process, and treating flue gas are described in the following sections.

5.1 PRECOMBUSTION

Fuel selection is one of the most important factors in minimizing atmospheric emissions. The type and amount of emissions that must be controlled are directly related to the fuel that is burned. For example, natural gas is a very clean-burning fuel that is essentially free from sulfur, noncombustible gases, and solid residue. It is often used in areas where emission standards are the most stringent because there are essentially no SO₂ or PM emissions associated with natural gas combustion. Distillate and residual oils are also good fuel choices although their combustion typically produces some NO_x, SO₂, and PM emissions. Depending on the grade, residual oils generally have higher nitrogen, sulfur, and ash contents than distillate oils. From an emissions viewpoint, coal is the least desirable of all the fossil fuels because it can contain significant amounts of nitrogen, sulfur, and ash. Nonfossil fuels such as biomass, RDF, and paper mill sludge are somewhat cleaner burning fuels that typically have low-sulfur but high-ash contents.

For some types of fuel, it is possible to limit the amount of emissions that are released when the fuel is burned by employing precombustion emission control techniques. Two commonly used techniques involve fuel switching and beneficiation, or preparation. Both of these techniques are summarized in Table 5.1 and discussed below.

When feasible, fuel switching is a relatively easy emission control technique to apply. It can be as simple as replacing fuel that produces a certain level of emissions with a different fuel that produces less emissions. For example, when natural gas is used instead of fuel oil or coal, the need to remove PM and SO₂ from the flue gas is eliminated, and the amount of NO_x discharged into the atmosphere can be substantially reduced. When combustion of an alternative fuel results in reduced emissions, fuel switching is viewed as an effective emissions control technique. Although fuel switching can reduce emissions, it is not always feasible. When an adequate supply of the alternative fuel is not readily available, when boiler operations and efficiency are adversely affected, or when the cost of alternative fuel is prohibitive, fuel switching is typically not a viable option.

Beneficiation improves fuel quality by the use of mechanical, chemical, or other means of cleaning.¹ This technique is most often used to remove sulfur-bearing and ash-bearing materials from coal. For certain types of coal, beneficiation can reduce the sulfur content by up to 50% with a corresponding reduction in SO₂ emissions. Coal cleaning and preparation require specialized equipment to achieve the desired results. Design of this equipment takes advantage of the difference in specific gravity among the various coal constituents. For example, sulfur-bearing and ash-bearing materials such as shale, clay, and pyrite have higher densities than coal. Some of the methods used to remove these materials from coal

Table 5.1. Techniques for controlling emissions before combustion

Emission	Control technique	Description
NO _x	Switch to fuel with a low-nitrogen content	Removing nitrogen from fuel prior to combustion is generally not practical, but switching to fuel with a low-nitrogen content is an effective technique for reducing NO _x emissions. The level of nitrogen in natural gas is generally low, and fuel oil typically has a lower nitrogen content than coal.
SO ₂	Switch to fuel with a low-sulfur content	Switching from high- to low-sulfur fuel is an effective technique for reducing SO ₂ emissions.
	Perform beneficiation	Cleaning solid fuel such as coal by mechanical, chemical, or other means is an effective technique for maximizing the quality of the fuel. Eliminating noncombustible sulfur-bearing materials like pyrites and sulfates prior to combustion can reduce SO ₂ emissions. Refining petroleum to produce distillate oil is an effective processing technique that decreases the sulfur content of the fuel. Removing sulfur-bearing compounds prior to combustion is an effective technique for reducing SO ₂ emissions. Processing natural gas by removing hydrogen sulfide eliminates the possibility of SO ₂ emissions during combustion.
PM	Switch to fuel with a low-ash content	Switching from solid fuel such as coal, which has a high-ash content, to oil or natural gas is an effective technique for reducing PM emissions.
	Perform beneficiation	Cleaning solid fuel such as coal by mechanical, chemical, or other means is an effective technique for maximizing the quality of the fuel. Eliminating noncombustible, ash-producing materials like metals, sand, glass, and rock prior to combustion can be a very effective technique for reducing PM emissions. Refining petroleum into distillate oil is an effective processing technique that decreases the ash content of the fuel. Removing ash prior to combustion is an effective technique for reducing PM emissions.

involve gravity concentration, flotation, dry processing, and dewatering.² Removing nitrogen from coal prior to combustion is a good way to reduce NO_x emissions, but it is generally not practical.

Another form of fuel beneficiation involves the processing of petroleum and natural gas after they are removed from the earth. In a refinery, petroleum is subjected to processing operations that produce a number of petroleum-based products, including distillate and residual oils. As discussed in Sect. 3.1.2, fuel oils are classified into five grades depending on their chemical composition and physical characteristics, including ash and sulfur contents. From an emissions viewpoint, distillate oils have less SO₂ and PM emissions potential compared to residual oils. Natural gas that contains sulfur-bearing alcohols and phenols (mercaptans) and a high percentage of hydrogen sulfide are generally processed to remove the undesirable constituents. This processing converts sour gas to sweet gas, a more desirable fuel with a reduced potential for SO₂ emissions.

5.2 COMBUSTION

During combustion, nitrogen and sulfur that are present in certain types of fuel oxidize to form NO_x and SO₂, respectively. In addition, PM consisting of unburned carbon and ash disperse throughout the flue gas. Selecting a technique that will effectively control emissions of these materials depends on factors such as the composition of the fuel, the design of the boiler, and the method of firing. Combustion control techniques that are effective in reducing NO_x and SO₂ emissions are summarized in Table 5.2

Table 5.2. Techniques for controlling emissions during combustion

Emission	Control technique	Description
NO _x	Operational modifications <ul style="list-style-type: none"> oxygen trim (OT) burner tuning (BT) low excess air (LEA) 	Minimizing the amount of excess oxygen supplied to the boiler can reduce thermal NO _x formation. OT, BT, and LEA can sometimes be used to successfully optimize the operation of burners by minimizing excess air without excessively increasing unburned fuel.
	Staged combustion air (SCA) <ul style="list-style-type: none"> burners out of service (BOOS) biased firing (BF) overfire air (OFA) 	Staging the amount of combustion air that is introduced into the burner zone can reduce the flame temperature and thereby reduce thermal NO _x formation. For multiburner units, taking certain BOOS can be an effective technique for staging combustion. Biasing the fuel flow to different burners can also be an effective technique. Injecting air into the boiler above the top burner level through OFA ports can decrease the primary flame zone oxygen level and produce an air-rich secondary zone where combustion is completed.
	Steam or water injection (SI/WI)	Quenching the combustion process with WI or SI can lower the peak flame temperature and result in reduced thermal NO _x production.
	Flue gas recirculation (FGR)	Recirculating a portion of the flue gas to the combustion zone can lower the peak flame temperature and result in reduced thermal NO _x production.
	Reducing air preheat (RAP)	Reducing the air preheat temperature when preheat is used can lower the peak flame temperature and result in reduced thermal NO _x production.
	Low-NO _x burner (LNB)	Using LNBs can reduce NO _x formation through careful control of the fuel-air mixture during combustion. Control techniques used in LNBs include staged air, staged fuel, and FGR as well as other methods that effectively lower the flame temperature.
	Fuel-induced recirculation (FIR)	An NO _x reduction technique applicable to boilers that burn gaseous fuels. FIR is similar to FGR except a portion of the flue gas is mixed with natural gas instead of combustion air. The effect of this mixture on the combustion process is to reduce the peak flame temperature.
SO ₂	Natural gas reburning (NGR)	Introducing natural gas downstream of the main fuel combustion zone can reduce NO _x emissions. The natural gas combustion products strip oxygen from NO _x molecules produced by combustion of the primary fuel thereby creating harmless molecular nitrogen.
	Limestone or dolomite can be introduced into FBC boilers to serve as a sulfur-capture sorbent	Controlling SO ₂ emissions during combustion in an FBC boiler can be accomplished by feeding limestone or dolomite into the bed where calcium oxide reacts with SO ₂ for a sulfur-laden sorbent that is removed as either bottom or fly ash.
	Except for FBC boilers, no techniques are available to effectively remove SO ₂ during combustion	Reducing SO ₂ emissions can be accomplished by either removing sulfur compounds from the fuel prior to combustion or employing FGD techniques after combustion (see Tables 5.1 and 5.4).
PM	Operational modifications	Unburned carbon particles can sometimes be reduced by adjusting the combustion process or changing certain fuel properties such as fineness.
	No techniques are available to effectively remove non-combustible PM during combustion	Controlling noncombustible PM emissions is most effectively accomplished after combustion by removing fine particles dispersed in the flue gas (see Table 5.4).

and described below. Aside from reducing unburned carbon through improved combustion efficiency, there are currently no commonly used techniques for controlling the formation of PM during combustion.

5.2.1 Nitrogen Oxides Control Techniques

Except for burners that premix fuel and air prior to combustion, rapid mixing of fuel and air during combustion produces high peak flame temperatures and excess oxygen within the combustion zone. These conditions promote thermal and fuel NO_x formation.² The rate at which NO_x is produced is strongly influenced by the combustion temperature and the amount of time the combustion gases remain at elevated temperatures. When the combination of high combustion temperatures and high oxygen concentrations act together, the creation rate for NO_x peaks at excess air levels ranging between 25 and 45% (Ref. 3). In this context, excess air refers to the amount of air above that needed for complete fuel combustion. For burners that premix fuel and air prior to combustion, peak flame temperature decreases as excess air levels increase which results in a decrease in NO_x formation.

Suppressing the formation of both thermal and fuel NO_x is a very effective technique for reducing NO_x emissions. However, preventing NO_x formation altogether is impossible because oxygen, nitrogen, and high temperature are integral parts of the combustion process. For natural gas, distillate oil, and non-fossil fuel firing, almost all NO_x emissions result from the formation of thermal NO_x. With coal, residual oil, and crude oil firing, the proportion of fuel NO_x can be significant and, under certain operating conditions, may be predominant.⁴

Reducing NO_x emissions by suppressing the formation of thermal and fuel NO_x can be accomplished by either modifying the way the fuel is burned or treating the flue gas before it is discharged into the atmosphere using flue-gas treatment techniques discussed in Sect. 5.3. In some cases, combinations of combustion control and flue-gas treatment are required to achieve the required emissions reduction. Approaches that are used alone or in combination to inhibit the formation of NO_x during combustion include

- reducing the concentration of oxygen in the combustion zone,
- reducing the concentration of nitrogen in the combustion zone,
- reducing the peak combustion temperature, and
- reducing the amount of time that the combustion gases remain at elevated temperatures.

Although reducing excess oxygen and decreasing the residence time at high temperature will reduce NO_x formation, note that changes in these parameters often influence boiler performance. For example, oxygen and temperature are important flame parameters that affect stability, radiant heat release, combustible burnout, flame appearance, and other boiler operating factors.⁵ Successful application of any NO_x control technique may involve changes in boiler equipment, design, or operation to achieve the desired level of NO_x emission reductions. The most effective NO_x emission control strategy is one in which NO_x formation is reduced as much as possible and boiler performance is affected as little as possible. Except in advanced burner concepts where air and fuel are premixed, combustion at either very low or very high excess air levels results in low NO_x formation. For most LNBS, the best combination of low NO_x formation and high boiler efficiency occurs when the amount of oxygen is just enough to assure complete fuel combustion.³ However, operation at very LEA levels can cause problems. It can result in incomplete combustion and the formation of CO that causes boiler efficiency to decrease. In addition, it can create unsafe conditions inside the boiler that can lead to an explosion.

Discussions in the following sections focus on NO_x emission control techniques that are based on the approaches described earlier. No attempt is made to identify or quantify the impacts on boiler operations and performance that can occur if one or more of these techniques is implemented. These issues can only be assessed on a case-by-case basis by taking into consideration the system design features and operating parameters.

5.2.1.1 Peak flame temperature reduction

Basic techniques for reducing the peak flame temperature generally involve the addition of air, flue gas, water, or steam into the combustion zone. These actions either limit the amount of oxygen available, dilute the energy input, or cool the combustion process. Effective peak flame temperature reduction can be achieved by quenching the combustion process using one or more of the following techniques:⁴

- WI/SI
- FGR
- FIR
- RAP

Selecting a boiler with a larger capacity than needed also has the potential to lower the peak flame temperature.

Use of WI/SI is very effective in reducing thermal NO_x formation. However, it is not widely applied because of its potential for large thermal efficiency penalties, safety concerns, and burner control problems.

In the FGR technique, a portion of the flue gas is returned to the combustion zone as a means of decreasing the peak flame temperature. When flue gas is mixed with fresh combustion air, the oxygen concentration of the combustion air is reduced. With less oxygen available for combustion, the peak flame temperature is reduced. During combustion, the recirculated flue gas also absorbs some of the heat, thereby further reducing the peak flame temperature. FGR can be implemented by itself or in combination with LNBs. Typical NO_x emission reductions using this technique range from 30 to 50%. For many natural-gas fired ICI boilers with LNBs, FGR is an integral part of the combustion control system.

FIR is an NO_x reduction technique applicable to boilers that burn gaseous fuels. It is similar to FGR except that a portion of the flue gas is mixed with the fuel instead of the combustion air. Use of this technique has several advantages. It lowers the peak flame temperature, reduces the oxygen concentration in the combustion zone, improves fuel-air mixing, and reduces the time under NO_x formation conditions. When the same volume of flue gas is used, FIR can be more effective at reducing NO_x than FGR. To minimize possible confusion, caution should be exercised when the acronym FIR is encountered because it is used to represent both fuel-induced recirculation and forced internal recirculation. The FIR burners, which use forced internal recirculation, are described in Sect. 5.2.1.6.

When preheated combustion air is supplied to a boiler, it can have a positive impact on boiler efficiency, but the increased operating temperature of the boiler can also have a negative effect on NO_x formation. By lowering the temperature of preheated combustion air, a decrease in the peak flame temperature is realized, and a corresponding reduction in NO_x formation is achieved. Although reducing the air preheat temperature is an effective NO_x reduction technique, its use is seldom practical. Energy penalties associated with decreased boiler efficiency can be severe.

5.2.1.2 Operational modifications

Air supplied to boilers contains the oxygen needed for combustion. When the availability of oxygen exceeds that required for complete fuel combustion (excess air), the remaining oxygen is released back into the atmosphere along with the flue gas. Limiting the amount of excess air that is supplied to a boiler can reduce NO_x formation by lowering the concentration of oxygen in the combustion zone. A technique that is sometimes used to optimize the combustion process is LEA. In this technique, excess air is minimized without excessively increasing unburned fuel emissions.

An LEA condition can be achieved through changes in operating procedures, control system settings, or both. For example, OT and BT are two relatively simple operational modifications that can be performed to limit the amount of excess oxygen available for combustion. In certain cases, these

adjustments can reduce NO_x emissions by as much as 15% (Ref. 4), but the actual degree of NO_x reduction depends on the fuel characteristics and burning conditions. For LNBS equipped with automatic rather than manual OT, it is sometimes possible to achieve excess air levels of 5% or less without adversely affecting boiler performance.³ Well-designed automatic boiler control systems that are based on a customized control strategy can effectively maintain low-emission levels and sustain peak boiler performance without periodic operator intervention. When advanced instrumentation and control devices are integrated into these systems, they are capable of maintaining efficient and safe operating conditions while providing the flexibility to accommodate a wide range of setting changes. Proper control strategy design and control loop tuning are key to optimum system performance.⁶

If air flow is too restricted because of overcontrol and if sufficient oxygen is not available for complete fuel combustion, boiler performance and efficiency will suffer. Also note that operating under these conditions may be unsafe. Conditions associated with poor boiler performance and reduced boiler efficiency include poor flame stability, an increase in CO emissions, high flame luminosity, and incomplete combustion. Besides posing operating problems with control precision, changes in boiler operations can have more serious consequences. Fuel-rich mixtures resulting from LEA can sometimes create conditions favorable for explosions within the combustion chamber. Before any modifications to boiler operations are authorized, steps should be taken to assure safety. Guidance provided in applicable standards, such as those adopted by the ABMA, CIBO, National Board of Boiler and Pressure Vessel Inspectors, National Fire Protection Association (NFPA), Underwriters Laboratories (UL), and ASME, that deal with boiler installation and operation should be considered as part of the overall decision-making process. A list of these documents is provided in Table 5.3.⁷⁻²⁴

Although modifications to boiler operations that involve changes in excess air levels can be effective in reducing NO_x formation, LEA is seldom used by itself as an emission control technique. Use of LEA is generally implemented with LNBS.

For boilers that use preheated combustion air, it is sometimes possible to reduce NO_x emissions by adjusting the preheat level. Introduction of cooler combustion air by lowering the temperature of the preheated air can be effective in quenching combustion and reducing the peak flame temperature. However, as discussed in Sect. 5.2.1.1, severe energy penalties are associated with reducing air preheat.

Table 5.3. Guidance for installation and operation of boilers

Organization	Designation	Title
American Boiler Manufacturers Association (ABMA)		<i>A Guide to Clean and Efficient Operation of Coal-Stoker-Fired Boilers</i> (Ref. 17)
		<i>Packaged Boiler Engineering Manual</i> (Ref. 7)
		<i>Combustion Control Guidelines for Single Burner Firetube and Watertube Industrial/Commercial/Institutional Boilers</i> (Ref. 14)
		<i>Guidelines for Boiler Control Systems (Gas/Oil Fired Boilers)</i> (Ref. 15)
		<i>Guidelines for Burner Adjustments of Commercial Oil-Fired Boilers</i> (Ref. 16)
American Society of Mechanical Engineers (ASME)	CSD-1	<i>Controls and Safety Devices for Automatically Fired Boilers</i> (Ref. 18)
	QFO-1	“Standard for the Qualification and Certification of Operators of High Capacity Fossil Fuel Fired Plants” (Ref. 22)
	QRO-1	“Standard for the Qualification and Certification of Resource Recovery Facility Operators” (Ref. 23)
Council of Industrial Boiler Owners (CIBO)		<i>Energy Efficiency Handbook</i> (Ref. 8)

Table 5.3. (continued)

Organization	Designation	Title
National Board of Boiler and Pressure Vessel Inspectors	NB-23	“National Board Inspection Code” (Ref. 19)
National Fire Protection Association (NFPA)	NFPA 31	“Standard for the Installation of Oil-Burning Equipment” (Ref. 9)
	NFPA 54	“National Fuel Gas Code” (Ref. 20)
	NFPA 85	“Boiler and Combustion Systems Hazards Code” (Ref. 21)
Underwriters Laboratories (UL)	UL 296	“Standard for Safety for Oil Burners” (Ref. 10)
	UL 726	“Standard for Safety for Oil-Fired Boiler Assemblies” (Ref. 11)
	UL 2096	<i>Commercial/Industrial Gas and/or Oil-Burning Assemblies with Emission Reduction Equipment</i> (Ref. 12)
	UL 2106	“Standard for Safety for Field Erected Boiler Assemblies” (Ref. 13)

5.2.1.3 Staged combustion

Staged combustion is an NO_x emission control technique that is based on the fact that combustion at either very low or very high excess air levels results in low-NO_x production. By mixing air and fuel at two or more locations in the boiler, it is possible to create zones of high and low excess air. Staged combustion can be achieved by adding either air or fuel at different stages in the combustion process.

In the first zone downstream of the burner, air is introduced into the boiler at a level that is insufficient for complete fuel combustion. This creates a fuel-rich mixture that inhibits NO_x formation. Further downstream, combustion products from the first zone are mixed with additional air. This air, which is sometimes mixed with a small amount of additional fuel, maintains the combustion process and allows it to continue until all of the fuel is burned. A deficiency of oxygen in the first zone and the low temperatures in the second zone contribute to reduced NO_x formation.

This technique, which is referred to as staged combustion air (SCA), can be implemented in different ways depending on the size of the boiler. In large boilers with multiple burners, staged combustion is sometimes achieved by adjusting some of the burners to operate rich and the others to operate lean. Another approach is to reduce the fuel flow rate to the burners and inject the necessary finishing air through OFA ports, located adjacent to or downstream from the burners. Although use of OFA ports is effective, a very practical way to implement SCA is to take certain burners out of service (BOOS) or bias the fuel flow to selected burners to obtain a similar air staging effect. For small boilers with one or only a few burners, one of the most popular methods is to use LNBS that incorporate SCA into their operation.

SCA can result in NO_x reductions of up to 50% for natural gas and 20% for No. 6 fuel oil and residual oils.³ Use of SCA is particularly effective on fuels such as coal and residual oil that have high nitrogen contents.

As discussed in Sect. 5.2.1.4, a second way to stage combustion involves the addition of fuel at different stages in the combustion process. Initially, this creates a fuel-lean mixture that lowers the flame temperature and thereby reduces the formation of NO_x. In the next stage, the excess air is combined with additional fuel to complete the combustion process. Some LNBS incorporate fuel staging into their design as a way to control NO_x formation.

5.2.1.4 Natural gas reburning

Another combustion modification technique that can be effective in reducing NO_x emissions involves the staging of fuel rather than combustion air. In this technique, a portion of the fuel is injected downstream of the main combustion zone. This fuel, which can range between 15 and 20% of the total fuel, is called reburn fuel. Hydrocarbon radicals generated by the reburning fuel strip oxygen from NO

molecules, thereby creating harmless molecular nitrogen.²⁵ This technique is best accomplished when the reburning fuel is natural gas. Used by itself, natural gas reburning (NGR) has been shown to reduce NO_x emissions by more than 60% (Ref. 26).

NGR has been investigated primarily for utility boilers, especially coal-fired units that are not good candidates for other NO_x reduction techniques such as LNBs. Examples of these boilers are cyclones²⁷ and stoker-fired combustion units. Application of the reburning technique on ICI boilers has been limited to some MSW and coal-fired stoker units that have the necessary extra height above the primary combustion zone.

5.2.1.5 Low-NO_x burners

In the drive to reduce NO_x emissions into the 30-ppm range, NO_x reduction techniques were implemented to lower peak flame temperatures and oxygen availability through the addition of various diluents to the combustion process. This was accomplished through the development of a new class of burners known as LNBs.

The LNBs are specially designed pieces of combustion equipment that reduce NO_x formation through careful control of the fuel-air mixture during combustion. The emission control strategy behind the design of an LNB generally reflects one or more NO_x reduction techniques including staged air, staged fuel, and FGR. As an example, in a staged combustion LNB, either air or fuel is added downstream of the primary combustion zone. To further reduce NO_x formation, fresh combustion air may be combined with recirculated flue gas to lower the peak flame temperature. Depending on which of these NO_x reduction technique is used, LNBs with staged combustion are subdivided into staged air burners and staged fuel burners.

Some LNBs create combustion conditions that produce a low flame temperature as a means for reducing NO_x formation. They either divide one large flame into several smaller flames or enlarge the radiative heat absorbing area of the flame. Certain LNB designs use multiflames with lean, premix combustion to break the total heat input into smaller flames, thereby lowering the peak flame temperature. Other designs achieve a low flame temperature by decreasing the temperature of preheated combustion air, injecting either steam or water into the combustion zone, or supplying the burner with recirculated flue gas.

Significant NO_x reductions are realized using LNBs that burn fuel under both excess air and LEA conditions. In these burners, a portion of the fuel is combined with more air than required for complete combustion. This low fuel concentration promotes a lower flame temperature. The remainder of the fuel is combined with less air than necessary for complete combustion, which inhibits NO_x formation. At a certain point beyond the burner where the two air-fuel mixtures combine, combustion is completed. When flue gas is recirculated through these burners, even further reductions can be realized.²⁵

Experience suggests that significant reductions in NO_x emissions can be realized using LNBs. The EPA reports that LNBs have achieved reductions up to 80% (Ref. 28), but actual reductions depend on the type of fuel and vary considerably from one burner installation to another.^{4,25,26,28-31} Typical reductions range from 30 to 50%; but under certain conditions, higher reductions are possible especially when OFA or another NO_x reduction technique is used in conjunction with LNBs.

5.2.1.6 Ultra low-NO_x burners

As new regulations are mandated to comply with ozone standards in the CAA, combustion research is focusing on the development of an advanced class of LNBs known as ULNBs. The objectives of the research are to produce burners that reduce NO_x emissions to single digits (less than 10-ppm volumetric, corrected to 3% oxygen*) and drastically lower CO emissions. The ULNBs are specifically designed to

*To correct parts per million NO_x to 3% O₂: NO_x at 3% O₂ = [NO_x measured × 17.9] ÷ [20.9 – O₂], where O₂ is oxygen measured in flue gas, dry basis (Ref. 32).

burn clean gaseous fuels, such as natural gas, that are essentially free of fuel-bound nitrogen. Their success is measured by how well combinations of NO_x reduction techniques can be applied to reduce thermal and prompt NO_x formation without contributing to efficiency losses.

So far, several ULNB concepts have been successfully tested, and some designs are now commercially available. As ULNB technology advances, emphasis is being placed on burner research aimed at optimizing the combustion process to increase operational flexibility and to minimize the impact on overall system performance. Despite rapid changes in the state-of-the-art, ULNBs are not universally adaptable to all boiler designs, and the greatest NO_x reductions are realized when a postcombustion NO_x control technique such as selective catalytic reduction (SCR) is used in conjunction with ULNBs.

Without identifying trade names, manufacturers, or proprietary details, the following discussions provide a brief overview of three ULNB concepts. Each design achieves single digit NO_x emissions by controlling both thermal and prompt NO_x formation through the use of recirculated flue gas in combination with at least one other NO_x reduction technique.

Reductions in NO_x emissions can be achieved by increasing the amount of excess combustion air that is mixed with the fuel before it enters the burner. By increasing the level of excess air, combustion occurs at a lower temperature, and the formation of thermal NO_x is reduced. Operation at a high excess air level also reduces the formation of prompt NO_x. The addition of flue gas from the boiler stack into the flame is also an effective and common technique to reduce peak flame temperatures and the formation of thermal NO_x. As the amount of recirculated flue gas increases, the level of NO_x emissions decreases until the stability limit of the burner is reached. The performance of burners that are designed to mix either excess combustion air or recirculated flue gas with the fuel before entering the burner has been demonstrated to produce very low NO_x and CO emissions. Partial support for this demonstration was provided by the DOE.³³

One of the most direct ways to reduce NO_x emissions involves avoiding fuel-rich regions, which reduces the formation of prompt NO_x, and lowering the flame temperature, which reduces the formation of thermal NO_x. In the rapid-mix ULNB, gaseous fuel is rapidly mixed with air near the burner exit, which results in an almost uniform fuel-air mixture at the ignition point. This rapid mixing virtually eliminates prompt NO_x formation and promotes complete fuel combustion. When fuel is burned under these almost ideal conditions, almost no CO and virtually no VOCs are formed. Thermal NO_x is minimized by adding recirculated flue gas to combustion air upstream of the burner to control the flame temperature. Contrary to conventional LNB theory, increasing excess air reduces NO_x formation in rapid-mix burner applications. Although rapid-mix burners perform like premix burners, there is one distinct difference. When fuel is added inside the burner, the extremely small premixed volume eliminates the possibility of flashback inherent in premix burner designs.³⁴ However, the very high excess air used in these rapid mix burners reduces boiler efficiency.

The FIR burners use a combination of premixing, staging, and interstage heat removal to control NO_x and CO formation by

1. premixing substoichiometric combustion air and significant internal recirculation of partial combustion products in the first stage to achieve stable, uniform combustion that minimizes peak flame temperature and high oxygen pockets;
2. enhancing heat transfer from the first stage to reduce combustion temperatures in the second stage; and
3. controlling second-stage combustion to further minimize peak flame temperature.

A field demonstration of the FIR burner on a commercial firetube boiler at Vandenberg Air Force Base confirmed stable performance during the 9 months of operation.³⁵ Burners based on this concept have no moving parts and avoid the need for external FGR.

5.2.2 Sulfur Dioxide Control Techniques

Controlling SO₂ emissions is best achieved by processing the fuel before it is fired, using techniques discussed in Sect. 5.1, or removing SO₂ from the flue gas after combustion has occurred, using techniques described in Sect. 5.3.

Combustion control techniques for reducing SO₂ emissions can be effective for FBC boilers where limestone or dolomite is used as the bed material. When operated at the optimum combustion temperature, chemical reactions within the bed significantly reduce SO₂ emissions. These reactions can absorb more than 90% of the sulfur released during combustion depending on the sulfur content of the fuel and the amount of sorbent added.² When limestone or dolomite is added to the bed, a reaction occurs between the calcium oxide (CaO) in the limestone or dolomite and the SO₂ in the gas. Sulfur capture is a function of the calcium-to-sulfur ratio, in-bed gas residence time, particulate size, bed temperature, and sorbent reactivity. The sulfur-laden sorbent is either collected as ash from the bottom of the boiler or removed as PM.

5.2.3 Particulate Matter Control Techniques

Solid material released during combustion of certain fuel such as coal consists of noncombustible ash-forming matter and unburned carbon particles. During combustion, these materials disperse throughout the flue gas as PM or accumulate inside the boiler as bottom ash or soot.

Reducing the amount of unburned carbon that is released during the combustion process can be accomplished by regulating the amount and location of air and fuel that are provided to the boiler. Changes in fuel properties, such as increasing fineness and adjustments to the boiler control system, can sometimes be effective in reducing unburned carbon. For stoker-fired and FBC boilers, reinjection of carbon-laden dust particles is also an effective way to reduce unburned carbon. Unburned carbon particle emissions or unburned carbon in the form of ash or soot will result in slightly reduced boiler efficiency.

Removal of noncombustible ash-forming matter cannot be readily accomplished during combustion. It is best accomplished by processing the fuel prior to combustion to remove ash-forming rocks and minerals or treating the flue gas after combustion has occurred using flue-gas treatment techniques.

5.3 POSTCOMBUSTION

When fuel processing and combustion control techniques do not reduce NO_x, SO₂, and PM emissions to acceptable levels, additional reductions may be required. In these situations, the only remaining option is to treat the flue gas before it is released into the atmosphere. Flue-gas treatment techniques generally involve special equipment located downstream from the boiler.³⁶ In most cases, the equipment performs only one function, and its design can be complex depending on the features of the boiler, the emissions being controlled, and the required level of emissions reduction. Although a cost impact is associated with implementing a flue-gas treatment technique, it is generally more cost-effective to include the equipment in the original design than to retrofit the installation. Techniques for treating flue gas to reduce NO_x, SO₂, and PM emissions are identified in Table 5.4 and described in the following sections.

5.3.1 Nitrogen Oxides Flue-Gas Treatment Techniques

Two techniques are commonly used to remove NO_x from flue gas. These techniques are selective catalytic reduction (SCR) and selective noncatalytic reduction (SNCR). Both of these techniques reduce NO_x emissions by converting NO_x to harmless molecular nitrogen. In addition to these techniques, which have been used effectively for a number of years, more advanced techniques are being developed.

Table 5.4. Techniques for controlling emissions after combustion

Emission	Control technique	Description
NO _x	Selective catalytic reduction (SCR)	Reducing NO _x emissions can be accomplished using the SCR technique in which a reductant (ammonia gas) is injected in the flue-gas stream before it passes through a catalyst bed. This technique disassociates NO _x to nitrogen gas and water vapor.
	Selective Noncatalytic Reduction (SNCR)	Reducing NO _x emissions can also be accomplished using the SNCR technique in which a reagent is injected in the flue-gas stream where NO _x is reduced to nitrogen gas and water vapor. Ammonia gas and aqueous urea are the two reagents most often used for this purpose.
SO ₂	Flue gas desulfurization (FGD) using <ul style="list-style-type: none"> • nonregenerable (throwaway) processes • regenerable (recovery) processes 	Removing SO ₂ from flue gas is most often accomplished in a wet scrubber where the flue gas is contacted with an aqueous slurry of lime or limestone. Reactions between the lime or limestone and the SO ₂ produce a calcium salt waste product.
		Circulating a sodium-based compound through a scrubber will also reduce SO ₂ emissions. Effluent from the scrubber is then mixed with lime or limestone to produce a calcium-sulfur waste product.
		Injecting a calcium-based sorbent such as lime into the flue-gas stream is also an effective technique for reducing SO ₂ emissions. Methods such as spray absorption, spray drying, or semiwet scrubbing produce a dry waste product that is collected along with the PM.
		Removing SO ₂ dispersed in flue gas can be accomplished by various advanced FGD techniques. Resulting sulfur compounds that have value include gypsum (wallboard), sulfur, and sulfuric acid.
PM	Cyclone separator	Separating PM dispersed in flue gas can be accomplished using a mechanical collector known as a cyclone. Separation is achieved as the particles are subjected to centrifugal and gravitational forces. Inside the cyclone, solid particles exit through an opening in the bottom, and the cleaned flue gas exits through an opening in the top.
	Wet scrubber	Removing PM dispersed in flue gas can be accomplished using a wet scrubber in which the particles impact water droplets. A spray tower is one type of low-pressure-drop wet scrubber, and a venturi-type scrubber is a high-pressure-drop wet scrubber.
	Electrostatic precipitator (ESP)	Charging particles that are dispersed in flue gas with electrical energy is an effective technique for reducing PM emissions. In an ESP, the particles are electrically charged and then attracted to a collecting surface rather than discharged into the atmosphere.
	Fabric filter (baghouse)	Collecting PM dispersed in flue gas can be accomplished by allowing the particle-laden gas to flow through a fabric filter. These fine-mesh filters are located inside a gas-tight structure known as a baghouse.

5.3.1.1 Selective catalytic reduction

SCR uses a catalyst and a reductant (ammonia gas, NH_3) to dissociate NO_x to nitrogen gas and water vapor. In practice, ammonia injection pipes, nozzles, and mixing grids are located upstream from the catalyst chamber. After a dilute ammonia-air mixture is injected into the flue-gas stream, dispersion occurs, and the catalytic reaction is completed within the catalyst chamber, such as the one shown in Fig. 5.1 (Ref. 37). This technique is used worldwide where high (70 to 90%) NO_x removal efficiencies are required. Use of SCR can be effective for boilers that burn a variety of fuels, including natural gas, oil, coal, and wood.²

A variety of catalyst shapes and formulations are available for use in the SCR process. The two leading shapes are honeycomb and plate.³⁸ Catalyst selection is based on the following factors:

- resistance to toxic materials,
- resistance to abrasion,
- mechanical strength to resist sootblowing,
- resistance to thermal cycling,
- resistance to the oxidation of SO_2 to SO_3 , and
- resistance to plugging.

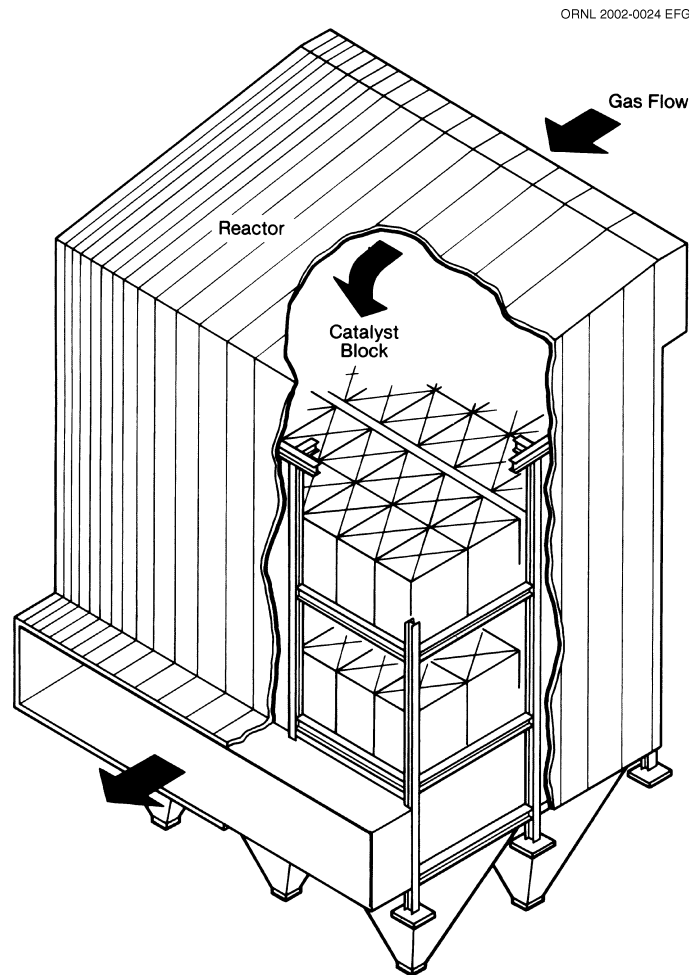

Fig. 5.1. Configuration of SCR reaction chamber. Source: Reprinted from Ref. 37.

Although catalyst formulations are proprietary, most catalysts typically fall into one of three categories: base metal, zeolite, and precious metal.² Catalysts can be used where exhaust gas temperatures range between 350 and 1,200°F, but they are typically designed to operate within a range of 450 to 850°F. Optimum performance generally occurs between 650 and 840°F depending on the fuel.² Operation above this temperature range can reduce the effectiveness of certain catalysts, and operations at lower temperatures increase the likelihood of ammonium sulfate formation within the catalyst bed. For these reasons, selecting the proper catalyst formulation for the operating conditions is critical to the success of this NO_x reduction technique. The useful operating life of a catalyst bed varies but often exceeds 2 years. At the end of this time, an additional catalyst must be added, or the bed must be replaced.

Process control of ammonia flow remains essentially constant during periods of normal operations with 1 mol of ammonia required to achieve a 1-mol reduction in NO_x. In practice, the actual mole ratio required to achieve a given level of NO_x reduction is slightly higher than this one-to-one ratio due to unreacted ammonia. This excess ammonia is known as ammonia slip. To account for reaction lag time during startup and shutdown, an ammonia-rich ratio is required for increasing loads, and an ammonia-lean ratio is required for decreasing loads.² It is important to keep ammonia slip levels low because ammonia can react with other combustion constituents such as sulfur trioxide to form ammonia salts. These salts are often very fine particles that can result in additional PM emissions. Because these particles are also sticky and corrosive, they can potentially cause downstream problems including plugging.

5.3.1.2 Selective noncatalytic reduction

SNCR uses a reducing agent of either ammonia (NH₃) or urea [(NH₂)₂CO] to dissociate NO_x to nitrogen gas and water vapor. In practice, the reducing agent is injected into the flue-gas stream within a specific temperature zone. With proper mixing and adequate residence time for the reduction reaction to occur, NO_x is converted to harmless molecular nitrogen. The acceptable temperature range for the reduction reaction is 1,400 to 2,000°F, but temperatures above 1,700°F are preferred. At temperatures below 1,600°F, chemical enhancers such as hydrogen are often required to assist the reaction. Above 2,000°F, the ammonia or urea may react with available oxygen to form additional NO_x. For new boilers that incorporate SNCR, it may be necessary to include special features in its design to accommodate the reduction reactions in a region of the boiler where optimal temperatures occur.

Mechanical components required to implement SNCR consist of storage and handling equipment for the ammonia or urea, equipment for mixing the reducing agent with a carrier (compressed air, steam, or water), and the injection equipment. Under carefully controlled conditions, reduction levels of 70% are possible, but reductions in the range of 30 to 50% are more typical.²

Although SNCR can be effective when adequate control is provided, injection of excess ammonia or urea can create operational problems. Ammonium salts can be produced when excess reducing agent reacts with flue-gas constituents such as sulfur trioxide. These salts, which may include ammonium sulfate and ammonium bisulfate, can pose undesirable consequences such as the formation of fine PM, fouling, or corrosion.

5.3.1.3 Emerging nitrogen oxides flue-gas treatment technologies

Advances in NO_x flue-gas treatment technology are focusing on the development of alternatives to ammonia-based methods. Although generally more expensive than SCR or SNCR systems, these methods are being considered because they do not require on-site storage of ammonia, avoid ammonia permitting issues, and eliminate ammonia slip.

One technique that has been developed and is currently on the market involves the use of a regeneration gas to regenerate a catalyst. The catalyst is loaded on a series of shelves that are located between isolation dampers. During operation, the flue gas passes over the catalyst for cleanup. While in service,

sections of the catalyst are routinely isolated from the flue gas by the dampers so that a regeneration gas can be passed over the catalyst. After regeneration, the catalyst is again exposed to the flue gas. At any one time, a portion of the catalyst is being regenerated. The catalyst is coated with potassium carbonate that absorbs the oxidized compounds. A reducing gas regenerates the potassium carbonate and drives off the absorbed nitrogen compounds as molecular nitrogen. This process is capable of reducing NO_x , CO, SO_2 , and certain VOC emissions.³⁹

Another technique that is under development involves the addition of ozone downstream from the dry FGD system. The ozone oxidizes NO_x to dinitrogen pentoxide (N_2O_5). Mercury, CO, and VOCs are also oxidized along with the NO_x . The oxidized products, including the N_2O_5 , are then removed in a caustic scrubber. One disadvantage to this method centers on the cost of generating ozone. In areas where the price of electricity is low or electricity is self-generated, the penalty may not be too severe.

5.3.2 Sulfur Dioxide Flue-Gas Treatment Techniques

Two approaches to characterizing postcombustion control techniques are effective in reducing SO_2 emissions.⁴⁰

One approach involves categorizing the various flue gas desulfurization (FGD) techniques into nonregenerable (throwaway) and regenerable (recovery) processes.⁴¹ For this discussion, nonregenerable and regenerable refer to the by-products, not the reagent. In a nonregenerable process, sulfur-bearing waste products that are derived from flue-gas processing are stored or treated prior to disposal. Regenerable processes recover the SO_2 in some commercially useful form such as elemental sulfur or sulfuric acid.

The second approach is to categorize the FGD process as either wet or dry. A wet process saturates the flue gas with water vapor whereas a dry process does not.

Although the various FGD techniques are distinctively different in their implementation,⁴² they all involve chemical reactions that transform gaseous SO_2 into a liquid or solid sulfur-bearing compound. Flue-gas scrubbers that effectively reduce SO_2 emissions are often described as complex chemical plants.

5.3.2.1 Nonregenerable processes

Three widely used nonregenerable FGD techniques involve either lime or limestone wet scrubbing, the double-alkali (or dual-alkali) process, or lime dry scrubbing. Depending on the technique, the required desulfurization equipment is located either upstream or downstream from the PM collection system.

Lime or limestone wet scrubbing is a very common FGD technique. In these systems, flue gas is contacted with an aqueous slurry of either lime or limestone in a countercurrent absorber, or scrubber, which is located after the PM collection system. Inside the scrubber, the lime (CaO) or limestone, which is predominantly calcium carbonate (CaCO_3), reacts with SO_2 to form calcium salts. To sustain this reaction, fresh slurry must be continuously introduced as the calcium salts are removed for processing and disposal. Several wet FGD systems are in commercial use with SO_2 removal efficiencies as high as 98% (Ref. 43). The configuration of one type of wet scrubber is shown in Fig. 5.2.

In the double-alkali (or dual-alkali) process, lime or limestone is consumed, and wet calcium salts, consisting primarily of calcium sulfite and calcium sulfate, are produced as waste. Unlike the lime or limestone wet scrubbing process, SO_2 absorption and waste production are performed as separate operations in the double-alkali process. Absorption is accomplished by circulating a soluble alkali such as NaCO_3 , NaOH , or Na_2SO_3 through a scrubber. Effluent from the scrubber, which contains sodium-sulfur compounds, is then mixed with lime or limestone to produce a calcium-sulfur waste product. Sodium that is lost as a result of entrainment in the waste can sometimes complicate the disposal process because sodium sulfate contributes to surface and groundwater contamination. This process, which is located downstream from the PM collection system, results in excellent SO_2 removal efficiency.

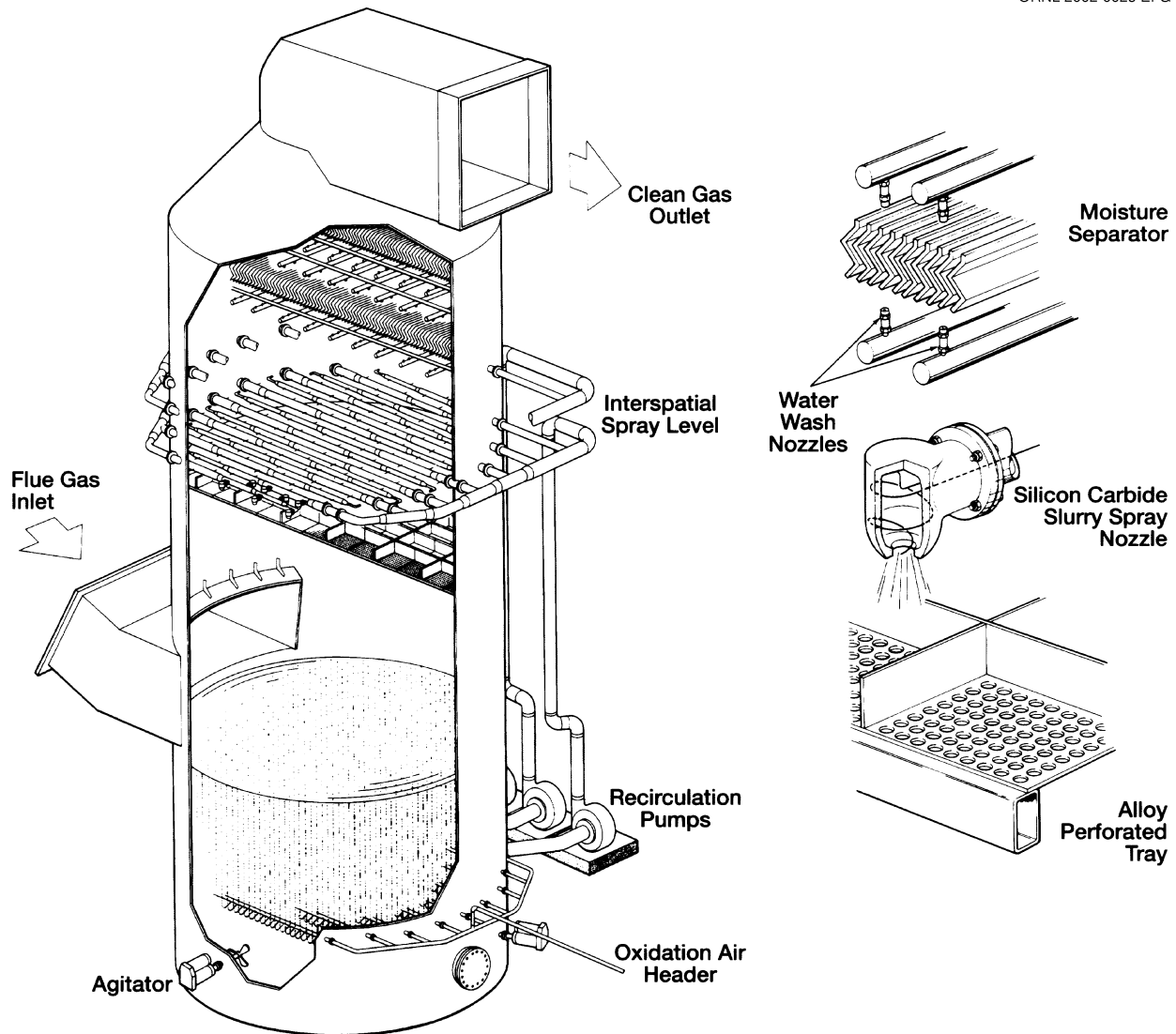

Fig. 5.2. Configuration of wet scrubber. *Source:* Reprinted from Ref. 37.

Lime dry scrubbing is a relatively simple SO_2 removal technique. Located upstream from the PM collection system, lime dry scrubbing involves spraying a highly atomized slurry or aqueous solution of an alkaline reagent into the hot flue gas to absorb the SO_2 . The predominant reagent used in dry scrubbers is slaked (hydrated) lime, but solutions of soda ash and its related compounds are sometimes used. Crystallized reaction products as well as fly ash from the boiler are collected in the PM collection system and then processed as waste. Wet scrubbers are generally selected for high-sulfur fuels. Dry scrubbers, which are not as effective as wet scrubbers for high-sulfur fuels, are generally selected for low-sulfur fuels. Use of lime dry scrubbers on large utility boilers is limited because of the high cost of the reagent, but their use on ICI boilers is more attractive because dry scrubbers are easier to implement than wet scrubbers. Lime dry scrubbing is sometimes referred to as spray absorption, spray drying, or semiwet scrubbing. The configuration of one type of dry scrubber is shown in Fig. 5.3.

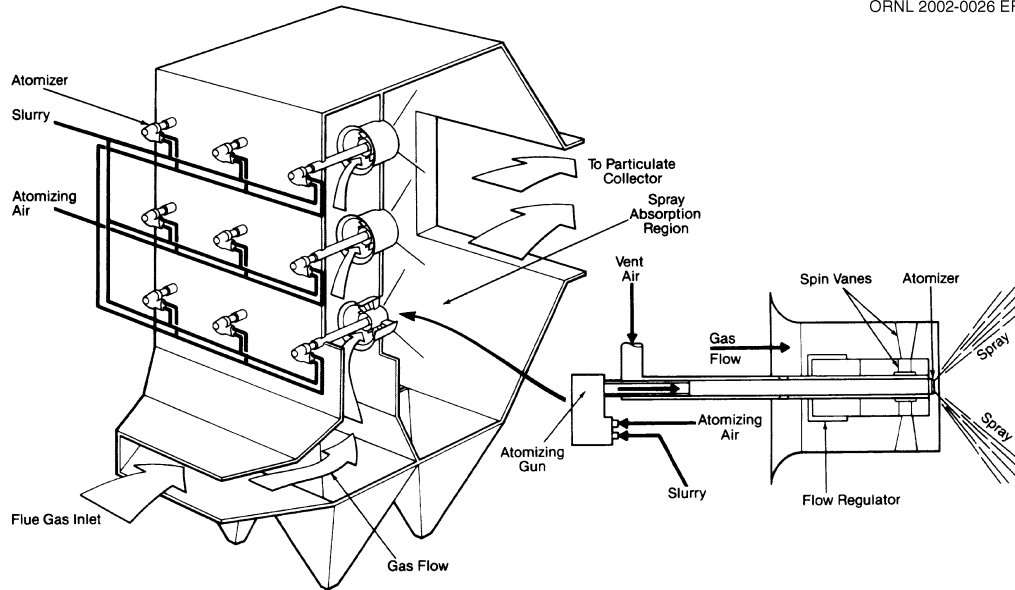

Fig. 5.3. Configuration of dry scrubber. *Source:* Reprinted from Ref. 37.

5.3.2.2 Regenerable processes

Regenerable FGD processes typically involve an expensive and complex system for producing marketable sulfur or sulfuric acid instead of valueless sulfur-bearing waste. Although SO_2 removal efficiency is generally greater than 90%, application of regenerable FGD is limited.⁴⁴ The processes are generally energy intensive and involve hazardous and potentially toxic gases that are not routinely associated with boiler operations.

In the advanced FGD demonstration project cofunded by government and industry, three techniques for reducing SO_2 emissions were implemented on large, coal-fired utility boilers.⁴⁵ Advanced features in the design of these projects demonstrated effective SO_2 absorption and the successful conversion of SO_2 to wall-board-grade gypsum. Other regenerable FGD processes involve magnesium oxide FGD, sodium sulfite FGD, and active-carbon absorption.⁴¹

5.3.3 Particulate Matter Flue-Gas Treatment Techniques

Four basic types of equipment are used to reduce PM emissions.⁴⁶ The primary functions of each type are to remove PM dispersed in the flue gas, keep the particles from reentering the flue-gas stream, and discharge the collected material. Equipment that can perform these functions includes mechanical collectors, wet scrubbers, electrostatic precipitators (ESPs), and fabric filters. Scrubbers such as those described in Sect. 5.3.2 are also effective at removing PM from ash-laden flue gas although their primary role is removal of SO_2 .

5.3.3.1 Mechanical collectors

Mechanical dust collectors, or cyclones, remove particles by centrifugal, inertial, and gravitational forces. As ash-laden gas enters the cyclone near the top, a high-velocity vortex is created inside the device. Heavy particles move outward due to centrifugal force and begin accumulating on the wall of the cyclone. Gravity continuously forces these particles to move downward where they collect in the lower, hopper region of the cyclone. The collected particles eventually discharge through an opening in the bottom of the hopper into a system that transports the particles to a storage area. Smaller and lighter

particles that remain suspended in the flue gas move toward the center of the vortex before being discharged through the clean-gas outlet located near the top of the cyclone.

Cyclones were adequate for PM control when emission regulations were less stringent and when firing methods produced larger particles. Now, with improved firing methods and emission limits based on particle size, cyclones are no longer being used as the primary method of PM removal. They are most effective on particles larger than 10 μm because collection efficiency drops dramatically as the particle size decreases.² The overall efficiency of a cyclone can only be established when the particle size distribution, specific gravity, and allowable pressure drop are known.

Use of cyclones in new combustion applications is primarily limited to fluidized-bed boilers where they are used to recirculate the bed material.² Although cyclones are used for this purpose, another type of PM collector such as a high-efficiency ESP or a fabric filter must be installed in series with the cyclone to meet PM emission limitations.

For applications where a cyclone is used to remove carbon-laden coarse particles from the flue gas stream, it may be possible to include equipment for reinjecting the collected particles back into the combustion chamber. Reinjection can be an effective technique for reducing carbon loss and thereby increase combustion efficiency.

5.3.3.2 Wet scrubbers

The PM can be removed by impacting the individual particles with liquid droplets inside a wet scrubber. A spray tower is a low-pressure-drop wet scrubber. It achieves PM removal by atomizing water and allowing the flue gas to flow through a mist or fog. Spray towers can be operated either counter-current or cocurrent with the flue-gas stream. Venturi scrubbers are high-pressure-drop wet scrubbers. Both types of wet scrubbers are good for removing PM as well as certain gases.

A venturi scrubber is a very effective PM removal device. As ash-laden flue gas passes through a flow-restricting venturi opening, the velocity of the flue gas increases significantly. Just as the flue gas exits the venturi, it is continuously wetted. The particles in the flue gas collide with the fluid and become entrained in the liquid droplets. Gravity causes these droplets to fall to the lower chamber of the separator where they impact into a liquid reservoir where the particles settle out of the liquid.

Venturi scrubbers can collect almost 100% of the very fine particles suspended in the flue gas.² However, venturi scrubbers are seldom used as the primary PM collection device because of excessive pressure drop.

5.3.3.3 Electrostatic precipitators (ESPs)

Removal of PM suspended in flue gas can be accomplished by electrically charging the particles in a device known as an ESP. The unit consists of a series of vertical collector plates with electrodes centrally located between the plates in a configuration such as the one shown in Fig. 5.4. Ductwork that connects the ESP to the boiler and the stack channels the ash-laden flue gas between the plates. When the plates are connected to an electrical ground and the electrodes are subjected to a high-voltage negative electrical charge, the particles take on a negative charge and begin migrating toward the positively charged collector plates. As flow continues, particles begin accumulating on the collector plate surfaces. Eventually, a layer of particles builds up and must be removed. One method for removing the layer involves rapping the plates. This sudden impact causes the particles to dislodge from the plates and fall into a hopper located at the bottom of the ESP. Particles that accumulate in the hopper are then transported to a storage area.

There are two basic configurations for ESPs. In the weighted-wire design, wires serve as the electrodes. These wires are suspended from a roof-mounted electrical distribution system. Weights attached to the bottoms of the wires ensure that the wires remain straight and vertical. The collector plates, which may be as long as 50 ft, are hung in rows like curtains at 12 to 16 in. on centers. For optimum

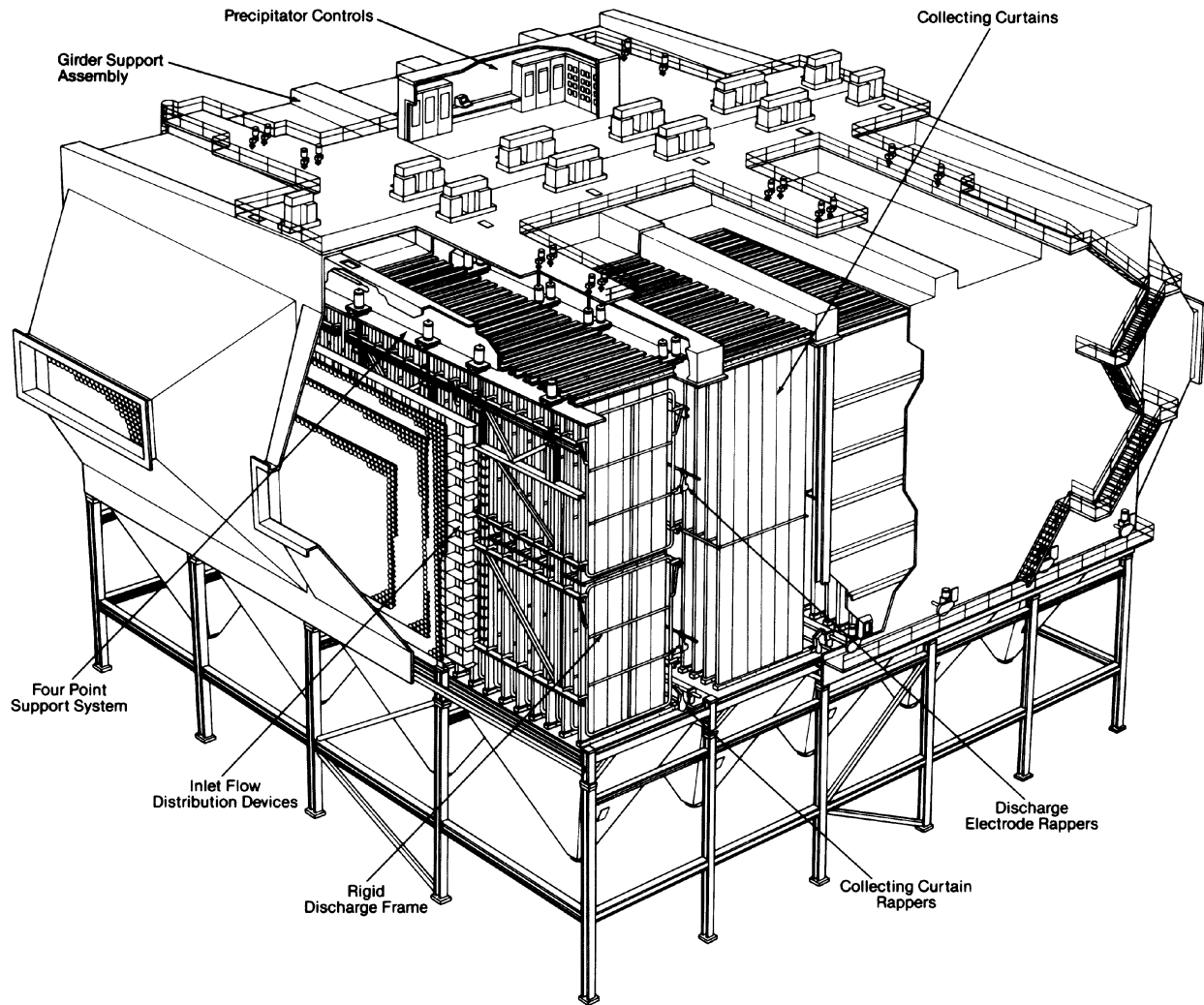

Fig. 5.4. Configuration of ESP. Source: Reprinted from Ref. 37.

performance with uniform electrical field and no electrical arcing, the alignment of the electrodes and collector plates must be maintained within tight tolerance.² Failure of a wire due to electrical arcing or other reasons is a recurring problem that results in performance deterioration. In the rigid-frame and rigid-electrode designs, strips of proprietary electrodes are supported by a structural framework that maintains the required alignment. The rigid-frame and rigid-electrode designs are more rugged with higher equipment reliability. All ESPs include a large, gas-tight metallic housing that is insulated to prevent heat loss.

Collection efficiencies of well designed ESPs can be 99.6% or higher, but it must be recognized that removal efficiency varies depending on the flue-gas loading and the design of the ESP. As the amount of PM suspended in the flue gas increases, the amount of PM that is not removed and escapes into the atmosphere also increases.⁴¹

5.3.3.4 Fabric filters

Fabric filters, such as the one shown in Fig. 5.5 (Ref. 2), are very effective devices for separating dry PM from flue gas. Separation occurs when the ash-laden flue gas passes through a porous layer of

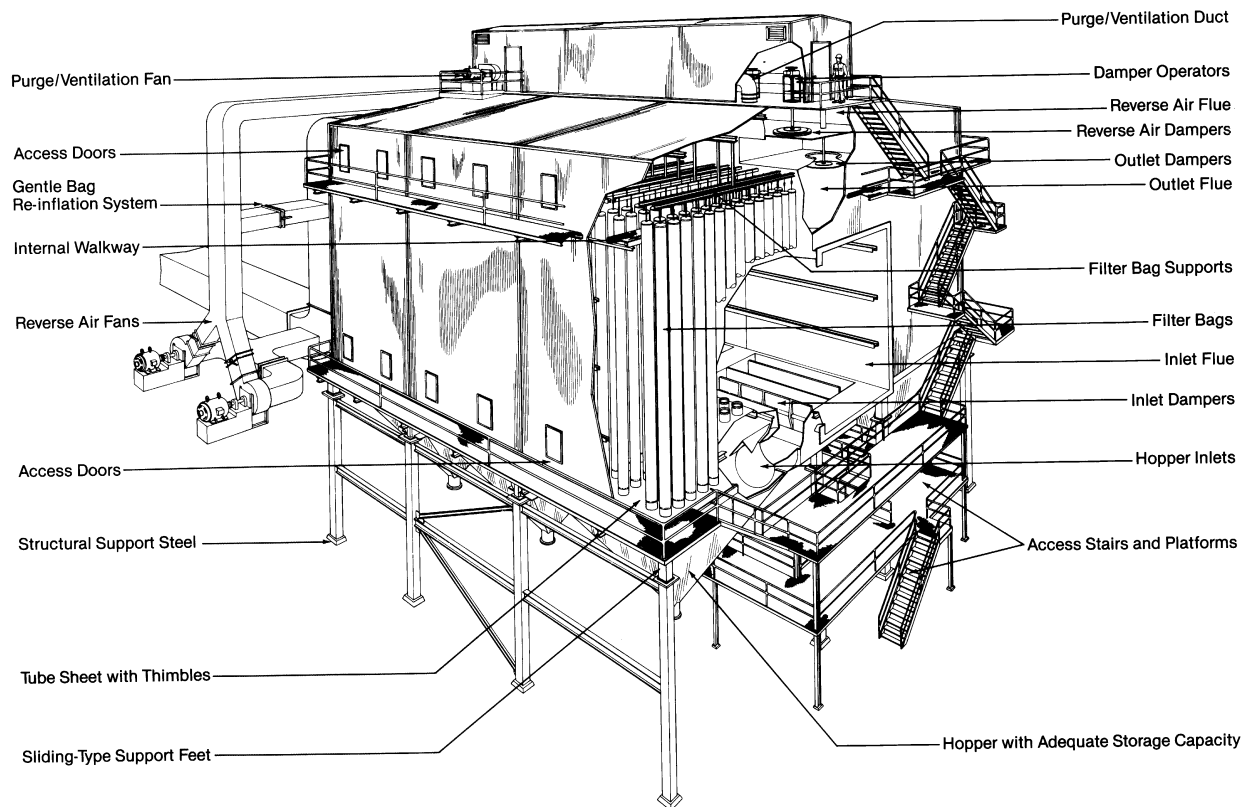

Fig. 5.5. Configuration of fabric filter or baghouse. *Source:* Reprinted from Ref. 2.

filter material. As the individual particles accumulate on the surface of the filter, they gradually form a layer of PM known as dustcake. Once formed, this layer of dustcake and not the filter material provides most of the filtration. Sieving action that occurs as the flue gas migrates around and through the captured particles provides better filtration than the fabric alone.

Each fabric filter consists of a long, vertically supported, small-diameter bag. When several of these filters are arranged in a gas-tight enclosure located between the boiler and the stack, the entire assembly is commonly referred to as a baghouse. In operation, flue gas enters the baghouse and is channeled into either the inside or the outside of the individual fabric filters. After the flue gas passes through the fabric, it flows out of the baghouse and toward the stack. The PM that dislodges from the filter material falls into a hopper at the bottom of the baghouse where it is removed and transported to a storage area. In operation, the dustcake is periodically removed by shaking the bags, reversing air flow through the bags, or subjecting the bags to a high-pressure pulse of air.

Woven fiberglass with an upper operating temperature of 500°F is a material commonly used to make bags for use as fabric filters. A typical bag has a diameter up to 12 in. and a length that varies up to 36 ft. Flexing action during cleaning influences bag life, but advances in fabric technology and surface finish have enhanced their longevity and improved their emissions control potential. Newer fabrics made with synthetic materials have an improved service life, superior resistance to chemical attack, and better dustcake-release properties; but the allowable operating temperature range is lower compared to woven fiberglass.

When the dustcake layer is sufficiently thick to cause a predetermined pressure drop, the fabric must be cleaned. Several methods for cleaning fabric filters have been developed. The generic name of the cleaning process provides a way to distinguish one method from another. For example, shaker, reverse-air, shake/deflate, and pulse-jet are different methods used to remove dustcake from fabric filters.⁴¹ In

shaker fabric filters, the bags are vigorously shaken to dislodge the dustcake. This method is applicable to fabric filters that collect particles on either the inside or outside surface. Reverse-air fabric filters use a current of cleaned flue gas to remove dustcake from the inside surfaces of fabric filters. A cleaning cycle is achieved when the reverse flow of flue gas caused the bag to partially collapse. Shake/deflate fabric filters represent a combination of shaking and reverse-air flow to dislodge the dustcake. Pulse-jet fabric filters are designed to collect dustcake on the outside surface of the bags. Cleaning occurs when the inside of the bags are subjected to a high-pressure pulse of air. Selecting one of these methods over another is often influenced by the difficulty with which the dustcake can be dislodged from the fabric filter.

Unlike ESPs whose removal efficiency depends on the flue-gas loading, fabric filters collect a given mass of PM per unit of fuel fired.² This means that the amount of PM released into the atmosphere is not influenced by the flue-gas loading. Fabric filters are capable of removing more than 99.9% of the PM in a flue-gas stream.² For these reasons, they are often considered the best available control technology for reducing PM emissions.⁴¹

5.4 REFERENCES

1. *Handbook of Energy Systems Engineering*, ed. L. C. Wilbur, John Wiley & Sons, Inc., New York, 1985.
2. *Steam, Its Generation and Use*, 40th ed., ed. S. C. Stultz and J. B. Kitto, Babcock and Wilcox, Barberton, Ohio, 1992.
3. *Boiler NO_x Control Field Manual*, American Gas Association, Baltimore, Maryland, November 1994.
4. *Alternative Control Techniques Document—NO_x Emissions from Industrial/Commercial/Institutional (ICI) Boilers*, EPA-453/R-94-022, U.S. Environmental Protection Agency, March 1994.
5. “Guidelines for Industrial Boiler Performance Improvement,” American Boiler Manufacturers Association, Arlington, Virginia, 1999.
6. S. G. Dukelow, *The Control of Boilers*, The Instrumentation, Systems, and Automation Society, Research Triangle Park, North Carolina, 1991.
7. *Packaged Boiler Engineering Manual*, 2nd ed., American Boiler Manufacturers Association, Arlington, Virginia, 1998.
8. *Energy Efficiency Handbook*, ed. R. A. Zeitz, Council of Industrial Boiler Owners, Burke, Virginia, November 1997.
9. “Standard for the Installation of Oil-Burning Equipment,” NFPA 31, National Fire Protection Association, Quincy, Massachusetts, 1997.
10. “Standard for Safety for Oil Burners,” UL 296, 9th ed., Underwriters Laboratories, Inc., Northbrook, Illinois, 1994.
11. “Standard for Safety for Oil-Fired Boiler Assemblies,” UL 726, 7th ed., Underwriters Laboratories, Inc., Northbrook, Illinois, 1995.
12. *Commercial/Industrial Gas and/or Oil-Burning Assemblies with Emission Reduction Equipment*, UL 2096, 2nd ed., Underwriters Laboratories, Inc., Northbrook, Illinois, 1999.
13. “Standard for Safety for Field Erected Boiler Assemblies,” UL 2106, 1st ed., Underwriters Laboratories, Inc., Northbrook, Illinois, 1994.
14. *Combustion Control Guidelines for Single Burner Firetube and Watertube Industrial/Commercial/Institutional Boilers*, American Boiler Manufacturers Association, Arlington, Virginia, 1999.
15. *Guidelines for Boiler Control Systems (Gas/Oil Fired Boilers)*, American Boiler Manufacturers Association, Arlington, Virginia, 1998.
16. *Guidelines for Burner Adjustments of Commercial Oil-Fired Boilers*, American Boiler Manufacturers Association, Arlington, Virginia, 1996.

17. *A Guide to Clean and Efficient Operation of Coal-Stoker-Fired Boilers*, American Boiler Manufacturers Association, Arlington, Virginia, 2002.
18. *Controls and Safety Devices for Automatically Fired Boilers*, CSD-1, American Society of Mechanical Engineers, New York, 1998.
19. "National Board Inspection Code," NB-23, National Board of Boiler and Pressure Vessel Inspectors, Columbus, Ohio, 2001.
20. "National Fuel Gas Code," NFPA 54, National Fire Protection Association, Quincy, Massachusetts, 1999.
21. "Boiler and Combustion Systems Hazards Code," NFPA 85, National Fire Protection Association, Quincy, Massachusetts, 2001.
22. "Standard for the Qualification and Certification of Operators of High Capacity Fossil Fuel Fired Plants," ASME QFO-1-1998, The American Society of Mechanical Engineers, New York.
23. "Standard for the Qualification and Certification of Resource Recovery Facility Operators," ASME QRO-1-1994, The American Society of Mechanical Engineers, New York.
24. *Combustion Control Guidelines for Multiple Burner Boilers*, American Boiler Manufacturers Association, Arlington, Virginia, 2002.
25. P. Basu, C. Kefa, and L. Jestin, *Boilers and Burners: Design and Theory*, Springer, New York, 2000.
26. *Reduction of NO_x and SO₂ Using Gas Reburning, Sorbent Injection, and Integrated Technologies*, Topical Report No 3, Rev. 1, U.S. Department of Energy, September 1993.
27. *Reburning Technologies for the Control of Nitrogen Oxides Emissions from Coal-Fired Boilers*, Topical Report No. 14, Clean Coal Technology, U.S. Department of Energy, May 1999.
28. *Nitrogen Oxides (NO_x), Why and How They are Controlled*, EPA 456/F-99-006R, U.S. Environmental Protection Agency, November 1999.
29. H. N. Soud and K. Fukasawa, *Developments in NO_x Abatement and Control*, IEACR/89, IEA Coal Research, London, United Kingdom, August 1996.
30. L. Garner, *Experience with Low NO_x Burners*, IEACR/99, IEA Coal Research, London, United Kingdom, November 1997.
31. *Reducing Emissions of Nitrogen Oxides via Low-NO_x Burner Technologies*, Topical Report No. 5, Clean Coal Technology, U.S. Department of Energy, September 1995.
32. P. Dockrill and F. Friedrich, *Boilers and Heaters: Improving Energy Efficiency*, CANMET Energy Technology Centre, Nepean, Ontario, Canada, August 2001.
33. J. D. Sullivan and A. Webb, *Development of the Radiation Stabilized Distributed Flux Burner*, DOE/ID/1332, U.S. Department of Energy, December 1999.
34. T. Webster, "Burner Technology for Single Digit NO_x Emissions in Boiler Applications," presented at the CIBO NO_x Control XIV Conference, San Diego, California, March 13, 2001.
35. J. K. Rabovitser and D. F. Cygan, *Demonstration of Forced Internal Recirculation (FIR) Burner for Firetube Boilers*, GRI-00/0105, Gas Research Institute, Chicago, Illinois, June 2000.
36. *Technologies for the Combined Control of Sulfur Dioxide and Nitrogen Oxides Emissions from Coal-Fired Boilers*, Topical Report No. 13, Clean Coal Technology, U.S. Department of Energy, May 1999.
37. *Our Boilers & Environmental Equipment*, E101-3216C, Babcock and Wilcox Company, Barberton, Ohio 1998.
38. *Control of Nitrogen Dioxide Emissions: Selective Catalytic Reduction (SCR)*, Topical Report No. 9, Clean Coal Technology, U.S. Department of Energy, July 1997.
39. R. Oegema, "SCONOX™ Emissions Control Technology in the Industrial Sector," presented at the CIBO NO_x Control XIV Conference, San Diego, California, March 13, 2001.
40. M. Takeshita and H. Soud, *FGD Performance and Experience on Coal-Fired Plants*, IEACR/58, IEA Coal Research, London, United Kingdom, July 1993.

41. *Combustion Fossil Power*, 4th ed., ed. J. G. Singer, Combustion Engineering, Inc., Windsor, Connecticut, 1991.
42. R. R. Lunt and J. D. Cunic, *Profiles in Flue Gas Desulfurization*, American Institute of Chemical Engineers, New York, 2000.
43. *SO₂ Removal Using Gas Suspension Absorption Technology*, Topical Report No. 4, Clean Coal Technology, U.S. Department of Energy, April 1995.
44. H. Soud, *Suppliers of FGD and NO_x Control Systems*, IEACR/83, IEA Coal Research, London, United Kingdom, November 1995.
45. *Advanced Technologies for the Control of Sulfur Dioxide Emissions from Coal-Fired Boilers*, Topical Report No. 12, Clean Coal Technology, U.S. Department of Energy, June 1999.
46. H. N. Soud and S. C. Mitchell, *Particulate Control Handbook for Coal-Fired Plants*, IEACR/93, IEA Coal Research, London, United Kingdom, July 1997.

6. SELECTION CONSIDERATIONS

Boiler owners and operators who need additional generating capacity face a number of legal, political, environmental, economic, and technical challenges. Important factors must be considered when selecting a new boiler:

- geographical location and site accessibility;
- plan area and height requirements;
- fuel type, price, and availability;
- boiler type, size, efficiency, price, and reliability;
- heating loads and load variations including:
 - acceptable pressure and temperatures ranges, and
 - required rates of heat delivery;
- federal, state, and local environmental regulations;
- regional air quality;
- emission limitations and options for controlling regulated pollutants; and
- construction and operating permit requirements.

As an aid in boiler and fuel feed system selection, emission control options for 14 of the most common boiler and fuel feed system combinations have been identified. These options reflect combustion of coal, fuel oil, natural gas, biomass, or RDF and are presented in figures throughout the following sections. The various boiler and fuel feed system combinations addressed in the figures are identified in Table 6.1.

Although emission control options identified in the figures represent proven techniques for reducing atmospheric emissions, the suitability and effectiveness of a particular option must be assessed on a case-by-case basis. By carefully examining the effectiveness of each option and understanding its overall impact on boiler performance, owners and operators can be confident that the BACTs are considered.

Details about emission control options for specific boilers are presented in the following sections to help owners and operators make informed technical decisions. Also included are typical design parameters for boiler and fuel combinations and performance data for some of the more common types of combustion and postcombustion emission control equipment.

Table 6.1. Common boiler and fuel feed system combinations

Watertube boilers	Firetube boilers
Coal-fired, stoker-fed boilers	Coal-fired, stoker-fed boilers
PC-fired boilers	Fuel-oil-fired boilers
Coal-fired FBC boilers	Natural-gas-fired boilers
Fuel-oil-fired boilers	Biomass-fired, stoker-fed boilers
Natural-gas-fired boilers	RDF-fired, stoker-fed boilers
Biomass-fired, stoker-fed boilers	
Biomass-fired FBC boilers	
RDF-fired, stoker-fed boilers	
RDF-fired FBC boilers	

6.1 BOILERS AND COMBUSTION EQUIPMENT

The process of selecting a low-emission boiler and combustion equipment is strongly influenced by the fuel that is chosen and the emission limitations that are imposed. For new boiler applications and modifications to existing boiler installations that must meet stringent federal, state, and local emissions

regulations, fuel selection is the most important consideration. Boiler size and design, equipment for preparing and burning the fuel, the required amount of heating surface and its placement, the type and size of heat-recovery equipment, and the techniques that must be applied before, during, and after the fuel is burned to reduce atmospheric emissions are all fuel-dependent.¹ Criteria for fuel selection generally focus on cost, availability, and environmental compliance. However, it is often advantageous to select a boiler that is capable of burning multiple fuels or fuel combinations. This approach provides backup and allows fuel switching for cost savings.

After a fuel has been chosen, the next step in the process involves identifying an appropriately sized boiler based on steam or hot water demand and a suitable fuel feed system. Although various ICI boilers are commercially available, a large percentage is classified as either firetube or watertube boilers. Tables 2.1 and 2.2 show the various firetube and watertube boilers that are commonly manufactured and the corresponding fuels that they typically burn. Other boiler designs not reflected in these tables are also manufactured for unique or special applications.

The required features of the fuel feed system depend primarily on whether the fuel is a solid, liquid, or gas. Some fuel feed systems are designed to handle fossil fuels such as coal, oil, or natural gas, while others can accommodate nonfossil fuels such as biomass or RDF. Various fuel feed systems for supplying fuel to boilers are described in Sect. 2.2. Discussions with boiler and combustion equipment manufacturers are often necessary to understand design details and performance history for specific boiler designs. Manufacturers can provide meaningful assistance in identifying candidate boilers and fuel feed systems that are suitable for use with various fuels.

During the boiler and fuel feed system selection process, it is important to identify the types and quantities of pollutants that will be emitted and the emission control techniques that are available for achieving environmental compliance. Techniques that are effective in reducing NO_x, SO₂, and PM emissions are subdivided into three general categories, depending on which stage in the combustion process they are applied. As discussed in Chap. 4, these categories include precombustion, combustion, and postcombustion emission control techniques. Although some of these techniques are only applicable to boilers that burn certain fuels, the suitability and effectiveness of a particular technique must be assessed on a case-by-case basis. Factors such as the layout of the facility, the type and amount of fuel that is burned, the configuration of the boiler and fuel feed system, and the required level of emissions reduction can influence the selection and design of emission control equipment.

To further assist in boiler selection, note that both watertube and firetube boilers can be used to generate hot water or steam. However, differences between their designs and heat input capacities can make one type more suitable than the other. Firetube boilers are typically not designed for high-pressure applications above about 300 psig, and their heat input capacities usually do not exceed 50 MBtu/h (Ref. 1), but larger firetube boilers are sometimes manufactured. Watertube boilers, which confine water and steam inside tubes, can be fabricated in large sizes, and their designs are well-suited for higher pressure applications up to 2,400 psig. When the total required heat input capacity is less than about 8 MBtu/h, consideration should be given to cast iron or tubeless boilers, because these designs are sometimes viable alternatives to firetube and watertube boilers. Table 6.2 shows typical ranges of heat input capacities for various boiler and fuel combinations.^{2,3} Additional factors to consider in selecting a low-emission boiler that burns either fossil or nonfossil fuel are discussed in the following sections.

6.1.1 Coal-Fired Boilers

Coal is burned extensively in utility and large industrial boilers. Heat input capacities for these units usually exceed 100 MBtu/h. For many smaller ICI boiler applications, coal is often not the fuel of choice. The added cost of coal handling, ash disposal, and emission control equipment makes coal a less attractive fuel compared to fuel oil or natural gas for these smaller boilers. In addition to economical considerations, coal-fired boilers must have larger combustion chambers than oil-fired or gas-fired

Table 6.2. Typical capacity ranges for combustion boilers

Boiler type	Boiler design/fuel type	Capacity range		
		Heat input (MBtu/h)	Output (boiler hp) ^{a,b}	Output (lb/h) ^{a,c}
Firetube	HRT/coal	0.5–50	15–1,500	500–50,000
	Scotch/coal	0.4–50	12–1,500	400–50,000
	Firebox/coal	0.4–15	12–500	400–15,000
	HRT/fuel oil or natural gas	0.5–50	15–1,500	500–50,000
	Scotch/fuel oil or natural gas	0.4–84	12–2,500	400–85,000
	Firebox/fuel oil or natural gas	<20	<600	<20,000
	HRT/nonfossil	2–50	60–1,500	2,000–50,000
	Firebox/nonfossil	2–20	60–600	2,000–20,000
Watertube	PC	100–1,500+	3,000–45,000+	100,000–1,500,000+
	Stoker/coal	0.4–550+	12–16,500+	400–550,000+
	Underfeed stoker	5–40	150–1,200	5,000–40,000
	Spreader stoker	<500	<15,000	<500,000
	Chain grate stoker	5–150	150–4,500	5,000–150,000
	FBC/coal	1.4–1,000	42–30,000	1,400–1,000,000
	Fuel oil	0.4–1,500+	12–45,000+	400–1,500,000+
	Natural gas	0.4–1,500+	12–45,000+	400–1,500,000+
	Stoker/nonfossil fuel	1.5–1,000	45–30,000	1,500–1,000,000
	FBC/nonfossil fuel	40–350	1,200–10,000	40,000–350,000
Cast iron	Coal	<0.4–8	12–240	400–18,000
	Fuel oil or natural gas	<0.4–8	12–240	400–8,000
Tubeless	Fuel oil or natural gas	<0.4–4	12–120	400–4,000

Source: Refs. 2 and 3.

^aValues are approximate based on heat input capacities reported in units of MBtu/h.

^bBoiler horsepower equals approximately 33,471-Btu/h output from and at 212°F.

^cTo convert from Btu/h to lb/h, assume 970 Btu/lb.

boilers of the same capacity, the velocities of the combustion gases in the convection passes must be lower, and emission control equipment for flue-gas treatment is generally required. These features, combined with coal storage and ash disposal requirements, increase the land area needed to site a coal-fired boiler. When all of these factors are considered, coal is often a less desirable fuel option, especially for smaller ICI boilers with heat input capacities below 50 MBtu/h.

In situations where coal combustion is economically attractive and environmentally acceptable, various firetube and watertube boilers can be selected. Firetube boilers that burn coal typically include an underfeed stoker to automatically supply fuel to the unit; but in special cases where automatic control is not essential, hand firing may be a viable option worth further consideration. Coal-fired watertube boilers are subdivided in three classes: PC-fired, stoker-fired, and FBC boilers. Discussions about each of these boilers are presented in Sect. 2.1.2. Major differences among these boiler classes are reflected in how the fuel is supplied to the boiler, the approach used to burn the fuel, and the method used to remove ash after combustion has occurred. Descriptions of various stoker and PC burner designs are provided in Sect. 2.2.

When selecting a fuel feed system for a coal-fired boiler, various factors must be considered. Note that stoker-fired boilers are generally less expensive than PC-fired boilers with the same output because they do not require special equipment to pulverize the coal. Although this may be an important selection consideration, a properly designed PC-fired boiler can have an efficiency advantage due to unburned carbon of less than 0.4% compared to stoker-fired boilers that can exhibit up to 8% carbon loss.² Carbon that is not burned is undesirable because it represents wasted energy. When equipment for controlling

PM emissions is considered, stoker-fired boilers have an advantage over PC-fired boilers. Larger ash particles produced by stoker-fired boilers can often be effectively removed using less costly mechanical collectors such as cyclone separators rather than more complex ESPs, fabric filters (baghouses), or wet scrubbers. The SO₂ emissions from PC-fired boilers are typically less than from stoker-fired boilers, especially when sulfur-bearing materials such as pyrite are removed from the coal during pulverization. When emissions of NO_x are considered, both firing systems are equally capable of controlling NO_x emissions. Suitable combustion control techniques for reducing NO_x emissions from stoker-fired boilers include

- operational modifications such as LEA
- SCA such as different proportions of undergrate and OFA
- FGR
- RAP
- NGR

Techniques for controlling NO_x emissions from PC-fired boilers include

- operational modifications such as BT, OT, and LEA
- SCA such as BOOS, BF, and OFA
- SI/WI
- FGR
- RAP
- NGR
- LNBS

After combustion of coal, flue-gas treatment techniques are often required to further reduce emissions. Various options for controlling emissions from coal-fired, stoker-fired and PC-fired watertube boilers are shown in Figs. 6.1 and 6.2, respectively.

An FBC boiler represents an alternative method for firing coal with distinct advantages from an emissions viewpoint. The primary driving force for using FBC boilers is reduced SO₂ and NO_x emissions. These boilers are designed to burn coal at low enough temperatures to minimize NO_x formation and at the optimum temperature level for calcining limestone, which enhances the capture of SO₂. By adding limestone or dolomite to the bed to serve as a sorbent, it is possible to burn high-sulfur coal without the need for expensive postcombustion sulfur removal equipment. If additional reductions in NO_x emissions are required, the combustion air within the boiler can be staged and flue gas can be recirculated. Due to the fineness of PM emissions from FBC boilers, fabric filters, which are less sensitive to ash properties than ESPs, are normally selected. Most FBC boilers are watertube boilers, especially among the larger units, but some firetube FBC boilers are also available. When very low SO₂ and NO_x emissions are required, the circulating fluidized bed is the preferred choice over the bubbling fluidized bed. Additional options for controlling emissions from coal-fired FBC boilers are shown in Fig. 6.3.

Coal-fired firetube boilers represent a very small portion of the total ICI boiler population.² Virtually all of these boilers are manufactured as package units and rely on an underfeed stoker to supply coal to the boiler. Options for controlling emissions from coal-fired firetube boilers are listed in Fig. 6.4.

6.1.2 Fuel-Oil-Fired and Gas-Fired Boilers

For environmental and economic reasons, the majority of ICI boilers are fired by fuel oil, natural gas, or a combination of these fuels. Boiler designs for these fuels are very similar with many units capable of firing both fuels either separately or in combination. Although more compact than coal-fire boilers, large fuel-oil-fired or natural-gas-fired watertube boilers are field erected with features similar to PC-fired boilers. These units are typically either wall-fired or tangential-fired with multiple burners.

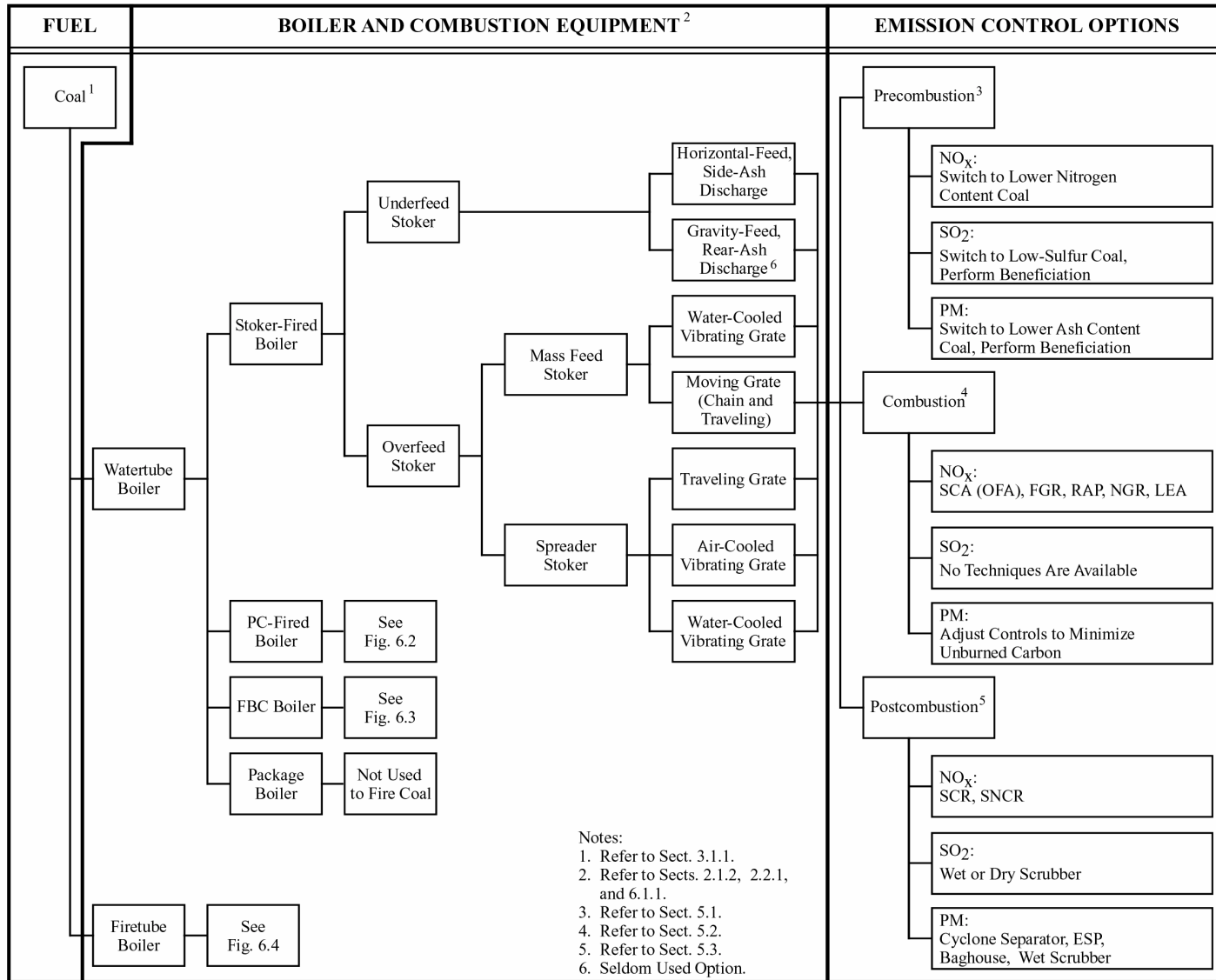

Fig. 6.1. Emission control options for coal-fired, stoker-fed, watertube boilers.

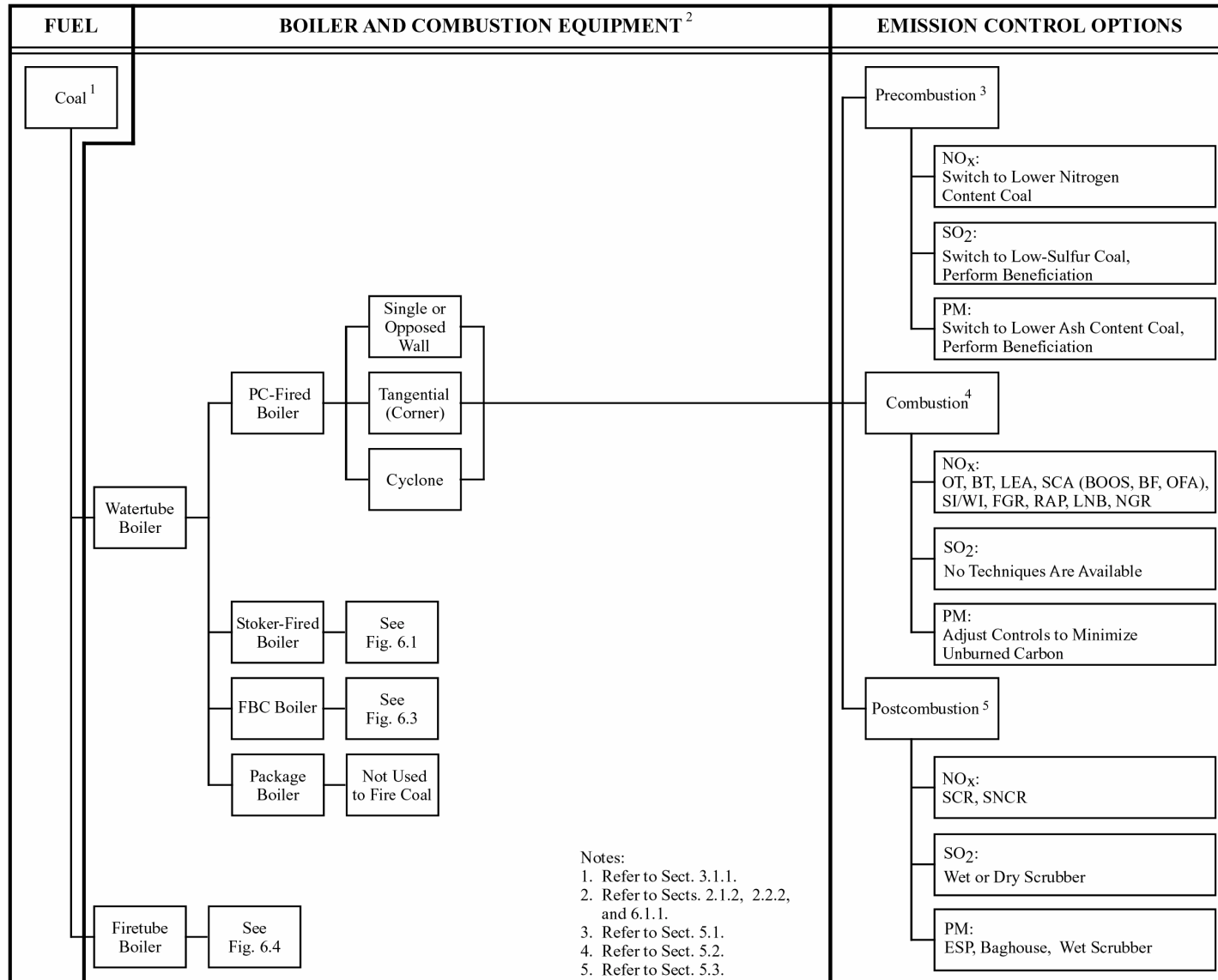

Fig. 6.2. Emission control options for PC-fired watertube boilers.

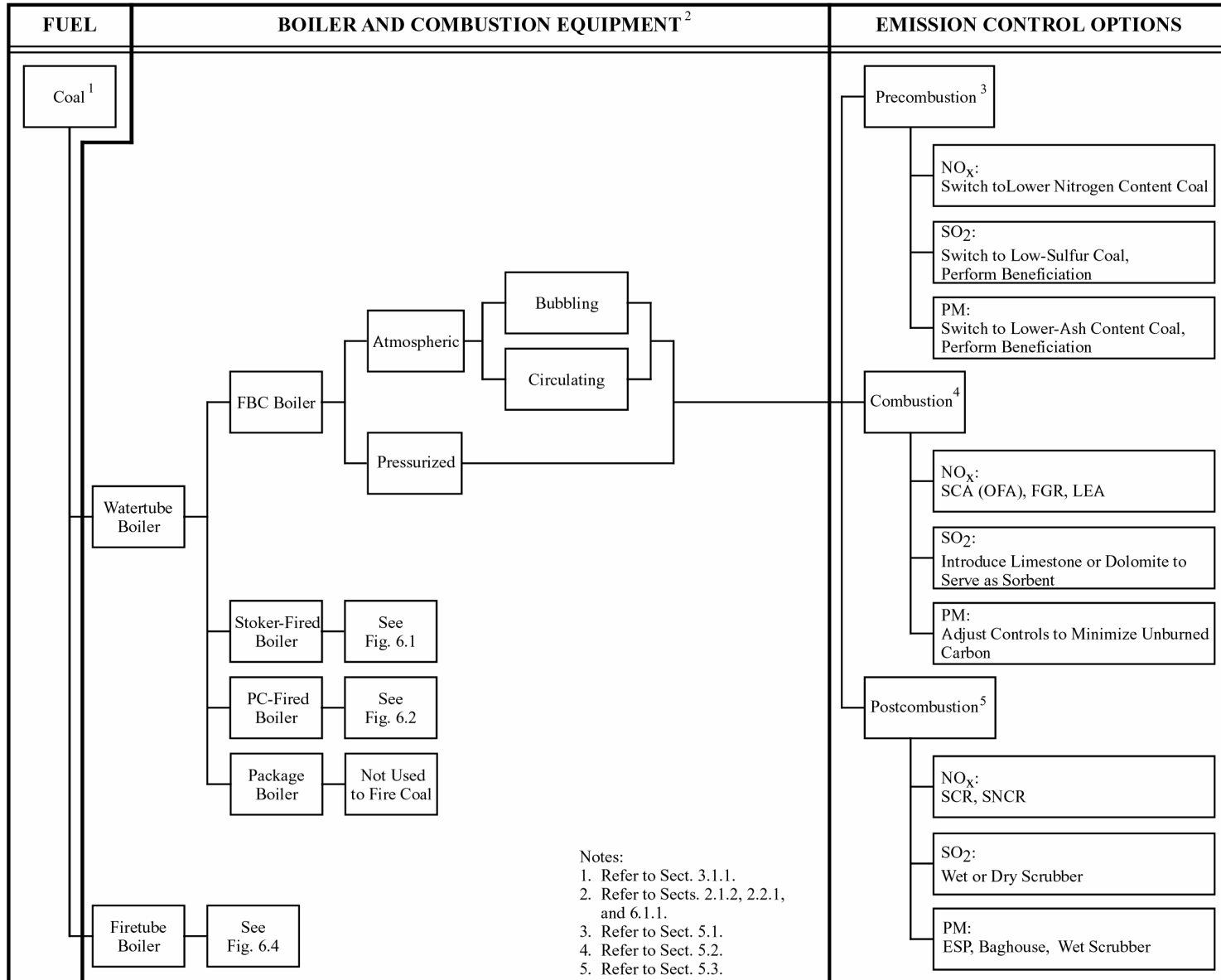

Fig. 6.3. Emission control options for coal-fired FBC wattertube boilers.

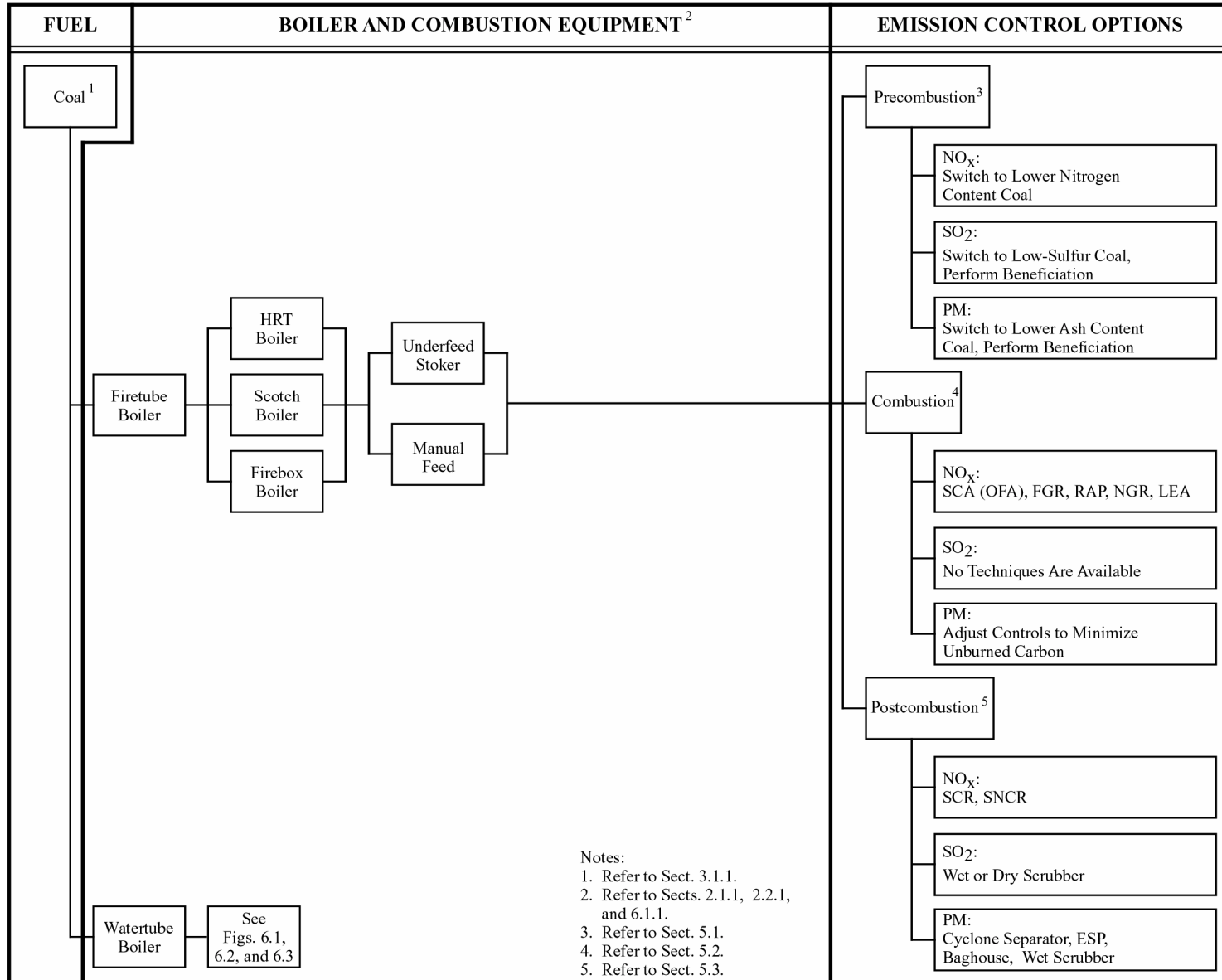

Fig. 6.4. Emission control options for coal-fired, stoker-fed, firetube boilers.

Multiple burners are required on large units because individual burners seldom exceed heat input capacities more than about 300 MBtu/h. Smaller watertube boilers are normally manufactured as package units with either an “A,” “D,” or “O” tube configuration. Firetube boilers that burn fuel oil or natural gas are almost all supplied as package units with a single burner. Scotch, HRT, and firebox boilers are the most common types of firetube boilers commercially available for burning fuel oil and natural gas. Additional descriptions of watertube and firetube boilers are provided in Sect 2.1. Discussions about burners are presented in Sect. 2.2.2.

Fuel oil is a widely available fossil fuel with characteristics that make it suitable for combustion in ICI boilers. It burns cleaner than coal, it can be stored in tanks at the site, it can be piped directly to the burner, and it can be atomized to burn like natural gas. Steam, compressed air, and mechanical methods, including pressure, are used to atomize fuel oil; but most grades except No. 2 require heating to lower the viscosity for improved handling and atomization. The types of emissions that must be controlled when fuel oil is burned depend on the properties of the fuel oil and the proportions of undesirable nitrogen-, sulfur-, and ash-bearing compounds that it contains. When fuel oil is burned, NO_x formed by fuel-bound nitrogen can account for 20 to 80% of the total NO_x emissions.⁴ Switching to fuel oil with a lower nitrogen content typically results in reduced NO_x emissions. Likewise, using lower sulfur fuel oil is a cost-effective way to reduce SO_2 emissions. Selecting appropriate combustion and postcombustion emission control techniques for fuel-oil-fired boilers often requires a laboratory analysis of the fuel to determine its exact composition. Suitable combustion control techniques for reducing NO_x emissions from fuel oil-fired boilers include:

- operational modifications such as BT, OT, and LEA
- SCA such as BOOS, BF, and OFA
- SI/WI
- FGR
- RAP
- NGR
- LNBS

Because certain fuel oils contain greater proportions of undesirable constituents, it is often more cost-effective to burn low-sulfur residual or distillate oil rather than high-sulfur residual oil. Depending on emission requirements, switching often minimizes or eliminates the need for postcombustion emission control equipment. Various options for controlling NO_x , SO_2 , and PM emissions from fuel-oil-fired boilers are shown in Fig. 6.5.

Natural gas is the most desirable fossil fuel for ICI boiler applications. It burns cleaner than coal and fuel oil, it is easy to handle, it mixes well with combustion air, and it contains very little sulfur and virtually no ash. Because natural gas is delivered by pipeline, on-site storage is typically not required. With no sulfur or ash, the emissions of concern include CO, VOCs, and NO_x . Suitable combustion control techniques for reducing NO_x emissions from natural-gas-fired boilers include:

- operational modifications such as BT, OT, and LEA
- SCA such as BOOS, BF, and OFA
- SI/WI
- FGR
- RAP
- NGR
- FIR
- LNBS
- ULNBS

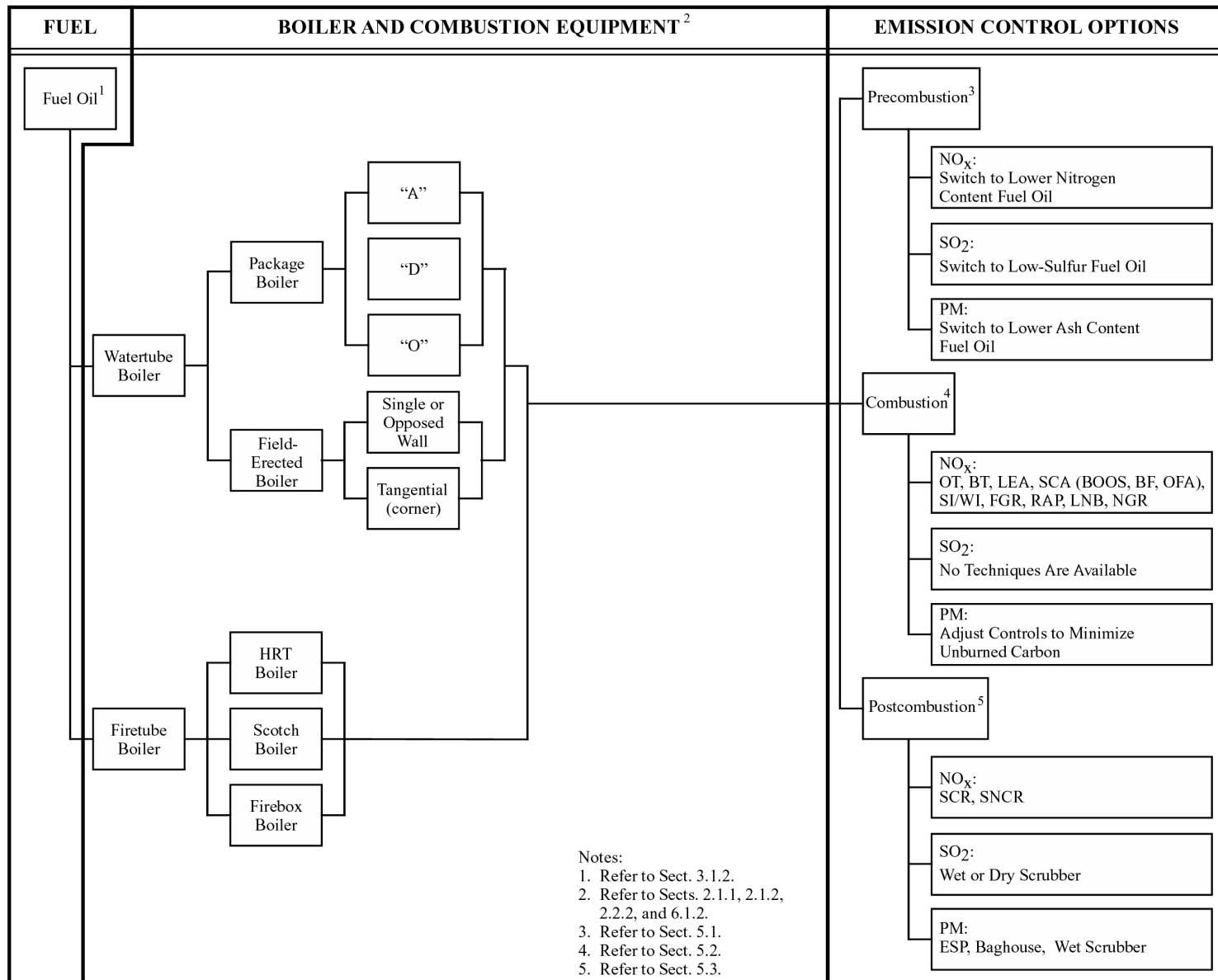

Fig. 6.5. Emission control options for fuel-oil-fired watertube and firetube boilers.

After combustion, additional reductions in NO_x emissions can be achieved by installing equipment to treat the flue gas. The two methods most often used are SCR and SNCR. Options for controlling emissions from natural-gas-fired boilers at various stages in the combustion process are shown in Fig. 6.6.

6.1.3 Nonfossil-Fuel-Fired Boilers

Although many different nonfossil fuels are used to fire boilers, two very popular solid fuels include biomass and RDF. Equipment for firing these two fuels is generally subdivided into stoker-fired and FBC boilers. These boilers may be either watertube or firetube designs with features similar to those for coal-fired boilers.

Fuels classified as biomass encompass a variety of nonfossil materials including wood. Other materials that are considered biomass are identified and described in Sect. 3.1.4. Biomass fuels are preferable to coal for certain stoker-fired and FBC boilers because they typically contain less ash and they usually generate relatively low NO_x and SO₂ emissions. Biomass fuel can be burned on a moving grate like stoker coal or introduced to the boiler by another type of conveying system. It is also possible to burn biomass fuel along with PC, fuel oil, or natural gas. When used in combination with these fuels, the individual biomass particles are generally supplied by a stoker, and the other fuels are introduced into the boiler using LNBS of an appropriate design.⁵ If biomass particles are sufficiently fine, it is sometimes possible to fire the fuel using burners that are similar in design and operation to PC burners. Discussions about stokers and burners that can be used to supply biomass to a boiler are presented in Sect. 2.2. Although biomass typically burns cleaner than coal, NO_x, SO₂, and PM emissions from biomass-fired boilers must often be controlled. Emissions control techniques that should be considered when selecting a biomass-fired boiler are shown in Figs. 6.7–6.9.

Boilers that burn RDF usually require a certain level of fuel processing prior to combustion. Fuel preparation efforts typically range from simple removal of noncombustible and bulky materials to shredding. The objective of these operations is to create a mixture of highly combustible fuel particles. Various stoker designs that are suitable for feeding and burning RDF in boilers are described in Sect. 2.2.1. When RDF is burned in a FBC boiler, it is often necessary to reduce the material to a maximum size of 2 in. by 2 in. so that the individual particles can be conveyed into the combustion chamber and burned uniformly in the bed.¹ Because of relatively cool combustion temperatures and low levels of fuel-bound nitrogen, sulfur-bearing compounds, and ash, combustion of RDF typically generates low levels of NO_x, SO₂, and PM emissions. When NO_x emissions are a concern, it may be necessary to install SNCR or SCR equipment to treat the flue gas before it enters the atmosphere. Depending on the fuel composition, installation of either a wet or dry SO₂ scrubber may only be necessary in areas where emissions regulations are the most stringent. Although the ash content of most RDF is low, particulate collection equipment is required to clean the flue gas and thereby minimize PM emissions. Cyclone separators, ESPs, baghouses, and wet scrubbers are generally used for this purpose. A compilation of emissions control techniques that should be considered when selecting a boiler for RDF are shown in Figs. 6.10–6.12. However, information in these figures may not apply in certain situations.

The EPA has established a special set of emissions regulations for units that burn more than 250 tons/d of municipal waste. These regulations, which are discussed in Sect. 4.1.3.2, place limits on cadmium, lead, mercury, hydrogen chloride, and dioxin/furan as well as SO₂, NO_x, and PM emissions. Techniques for reducing emissions of these pollutants are beyond the scope of this guide, but they should be investigated when boilers and combustion equipment for these applications are being selected.

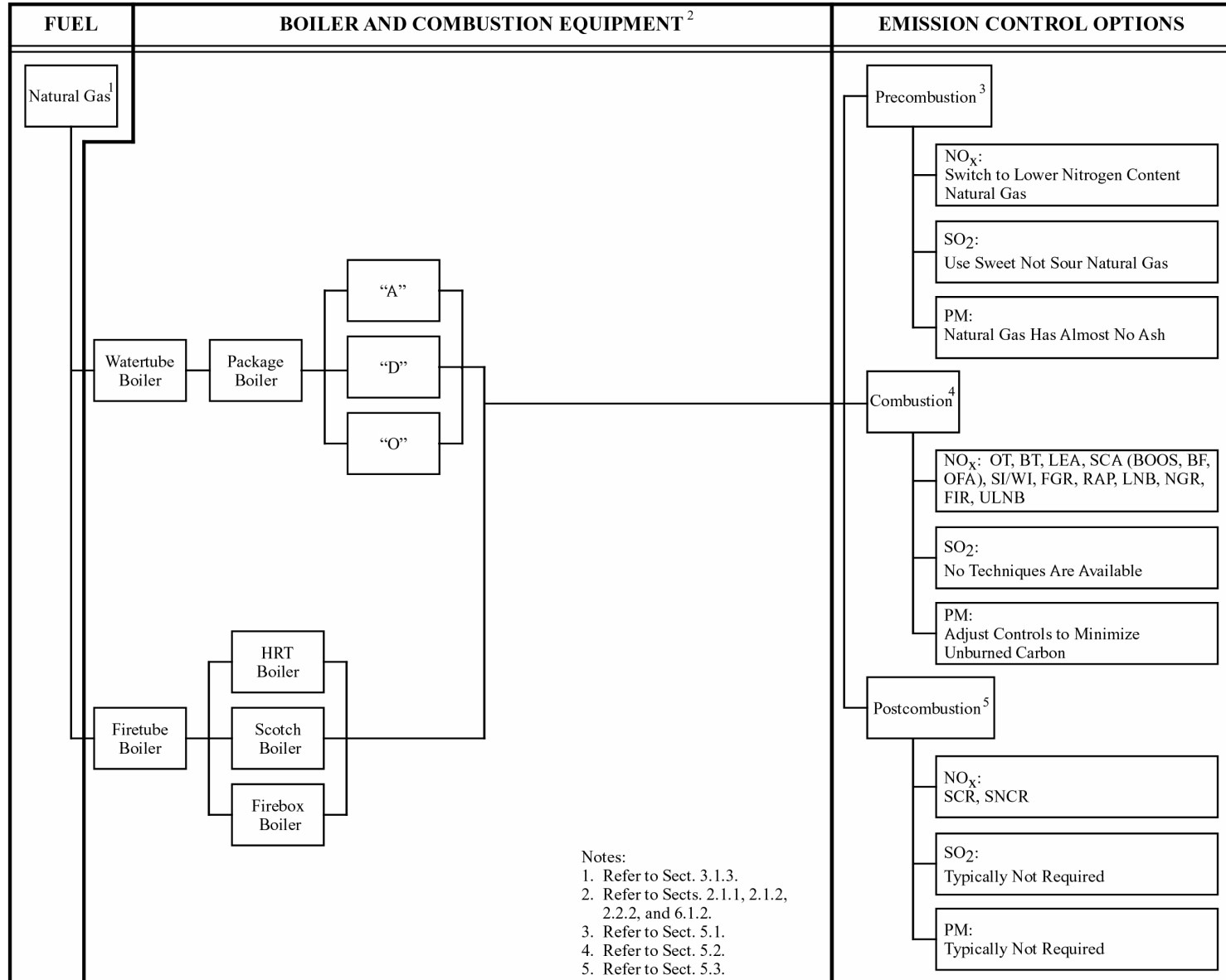

Fig. 6.6. Emission control options for natural-gas-fired watertube and firetube boilers.

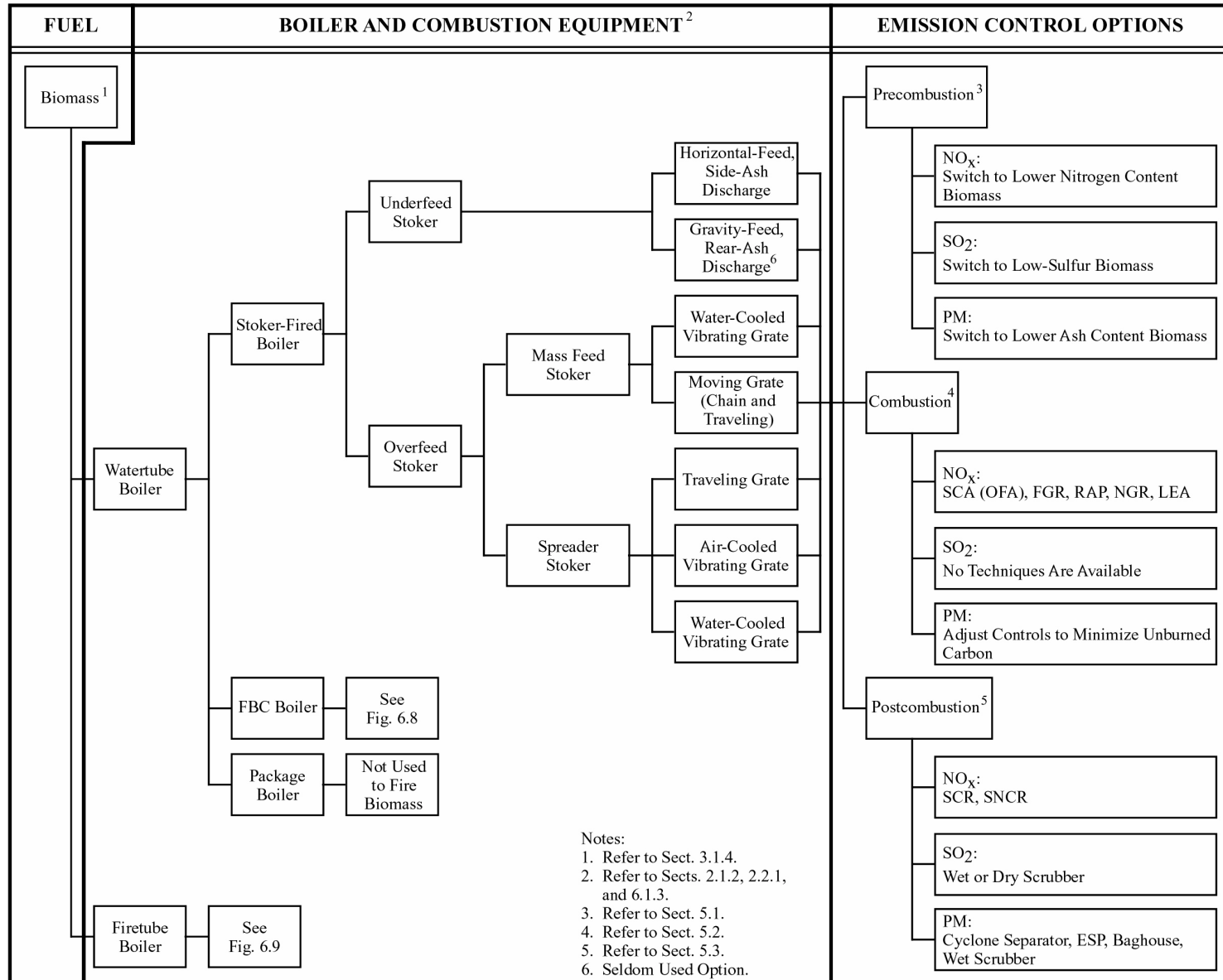

Fig. 6.7. Emission control options for biomass-fired, stoker-fed, watertube boilers.

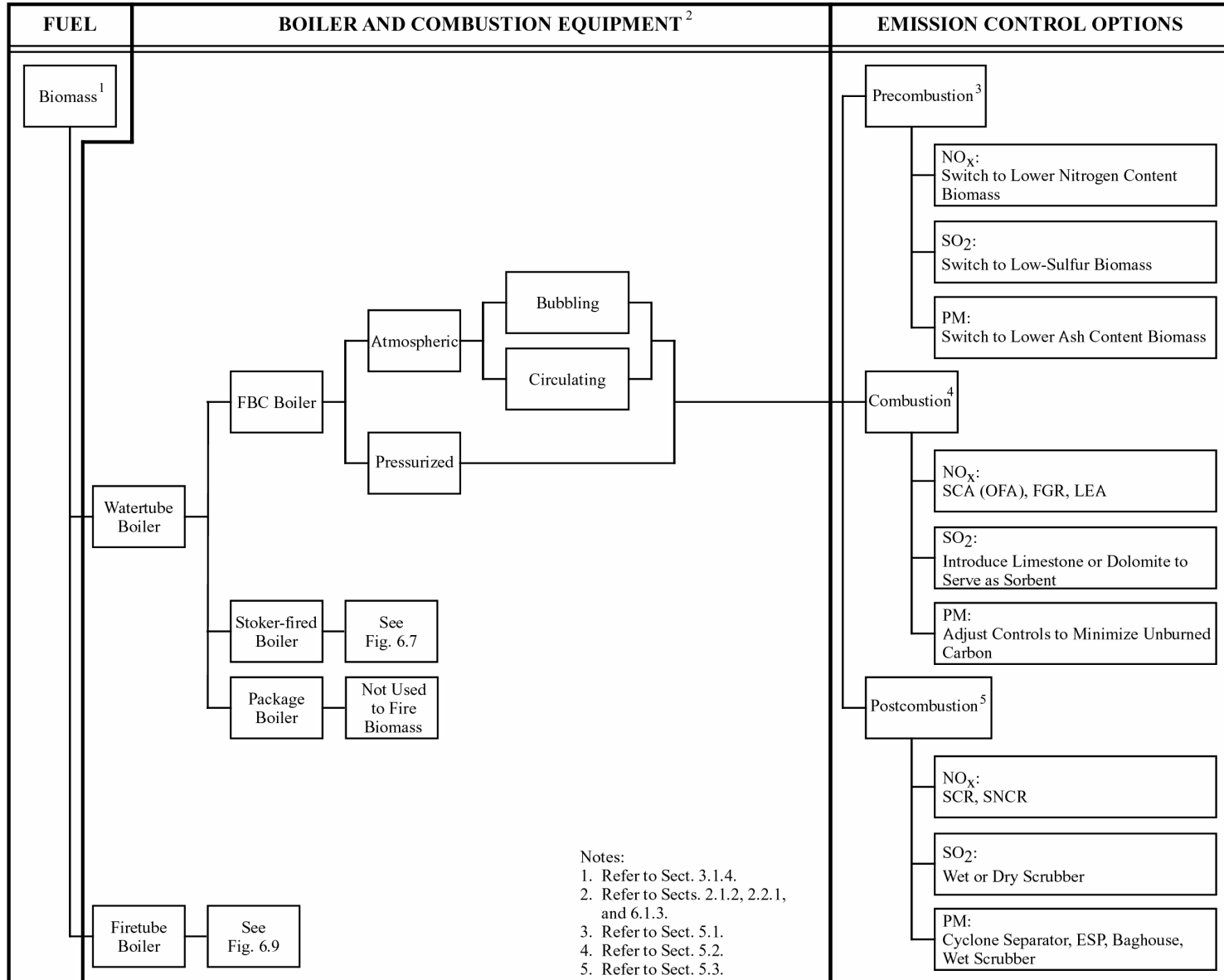

Fig. 6.8. Emission control options for biomass-fired FBC watertube boilers.

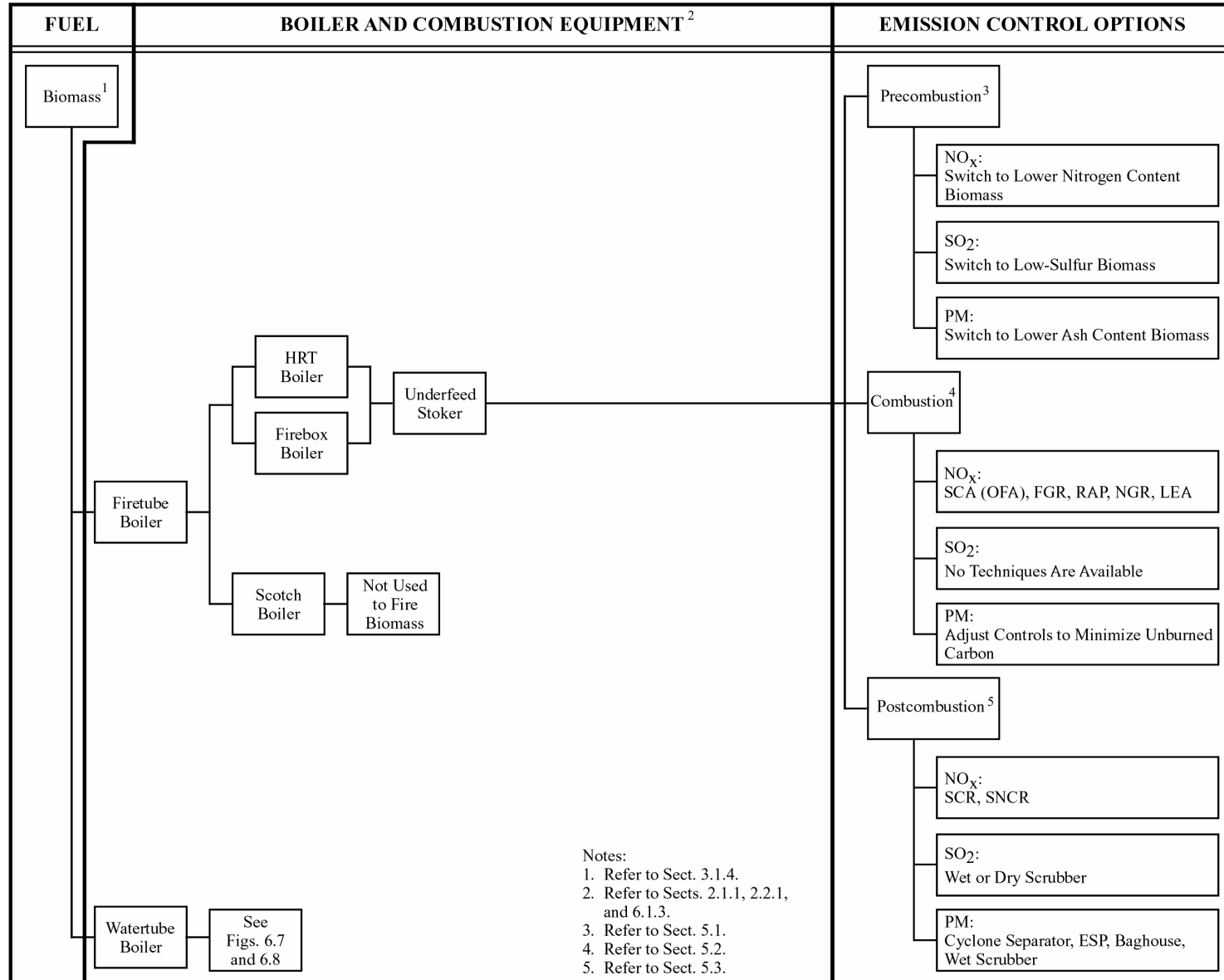

Fig. 6.9. Emission control options for biomass-fired, stoker-fed, firetube boilers.

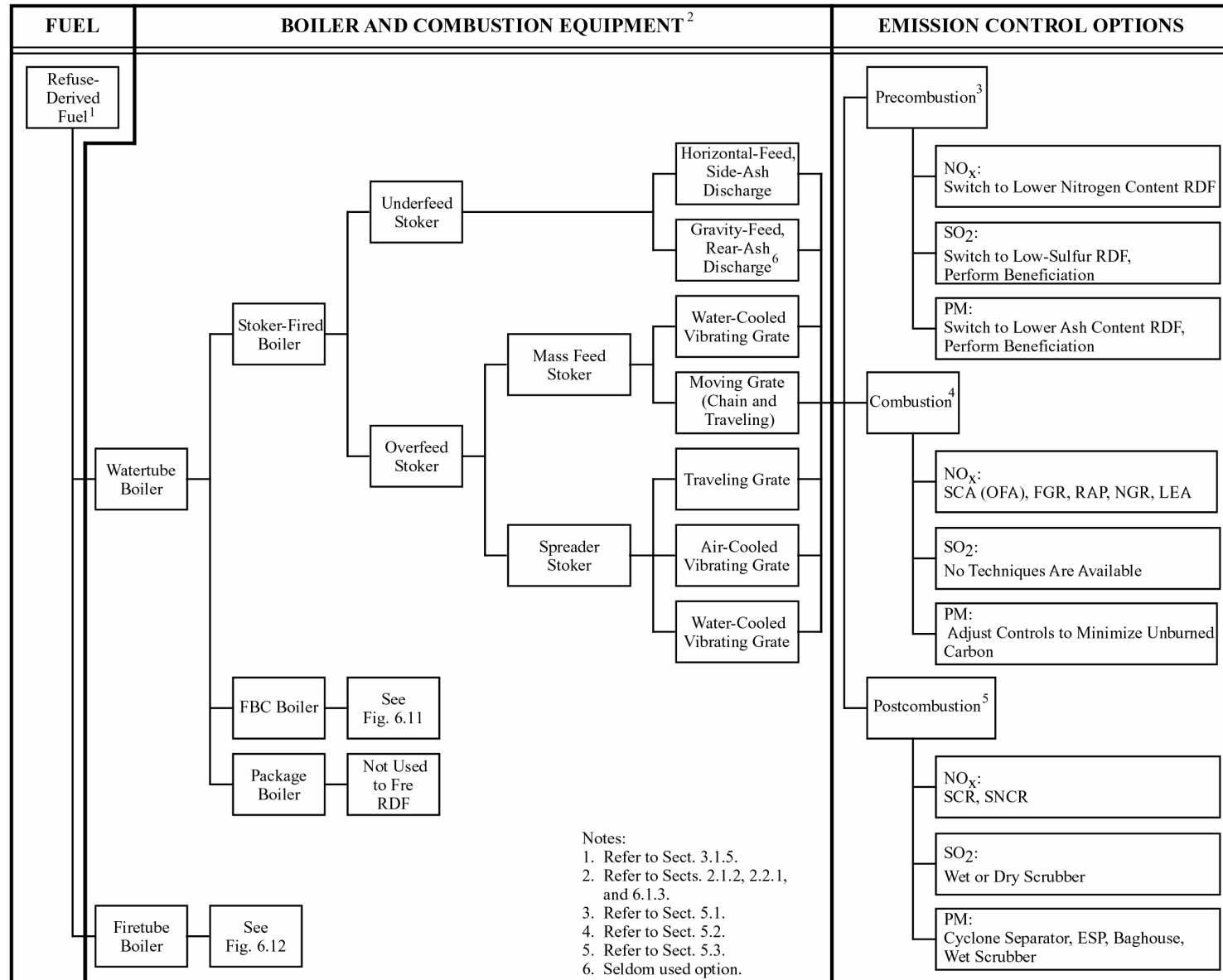

Fig. 6.10. Emission control options for RDF-fired, stoker-fed, wattertube boilers.

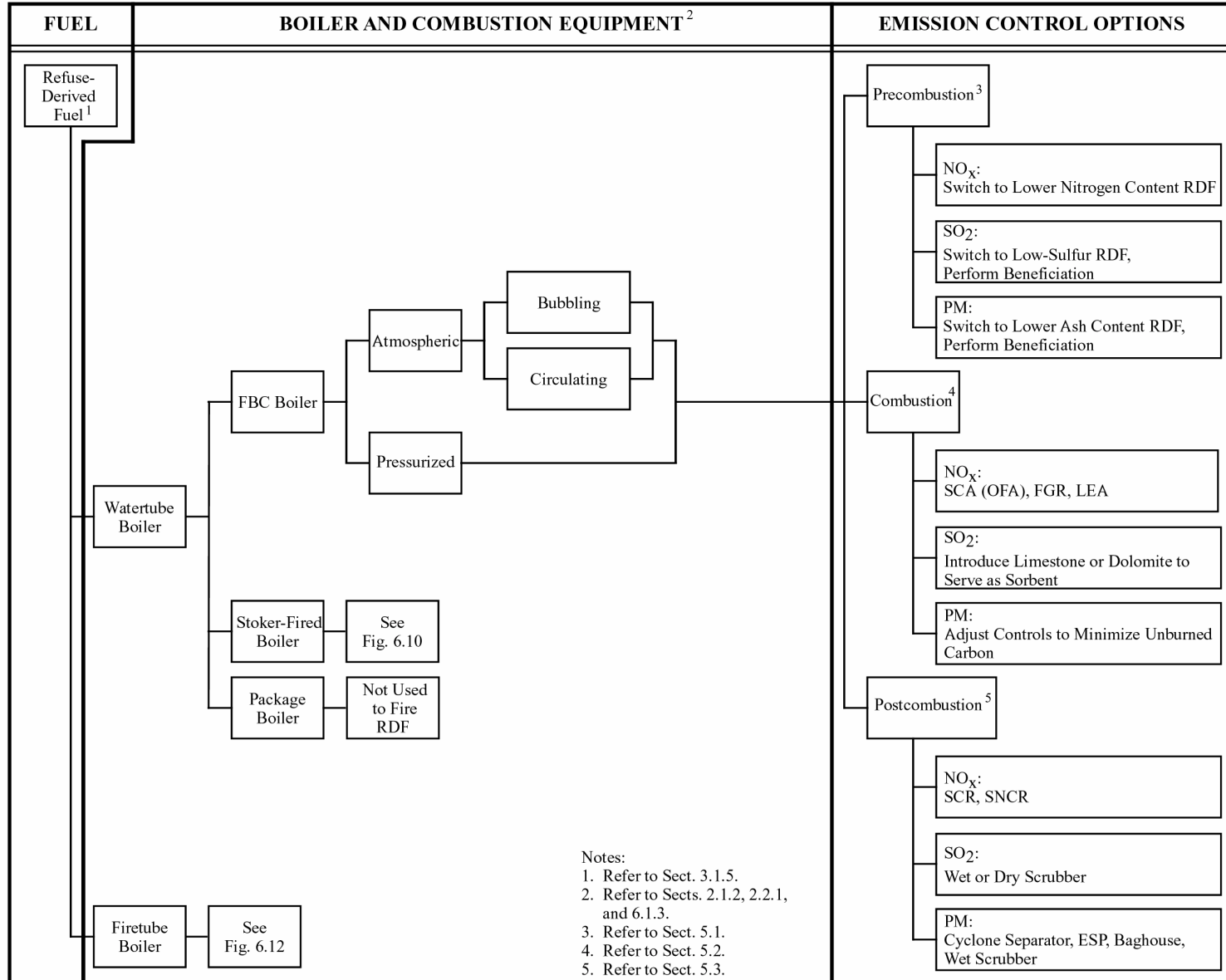

Fig. 6.11. Emission control options for RDF-fired FBC watertube boilers.

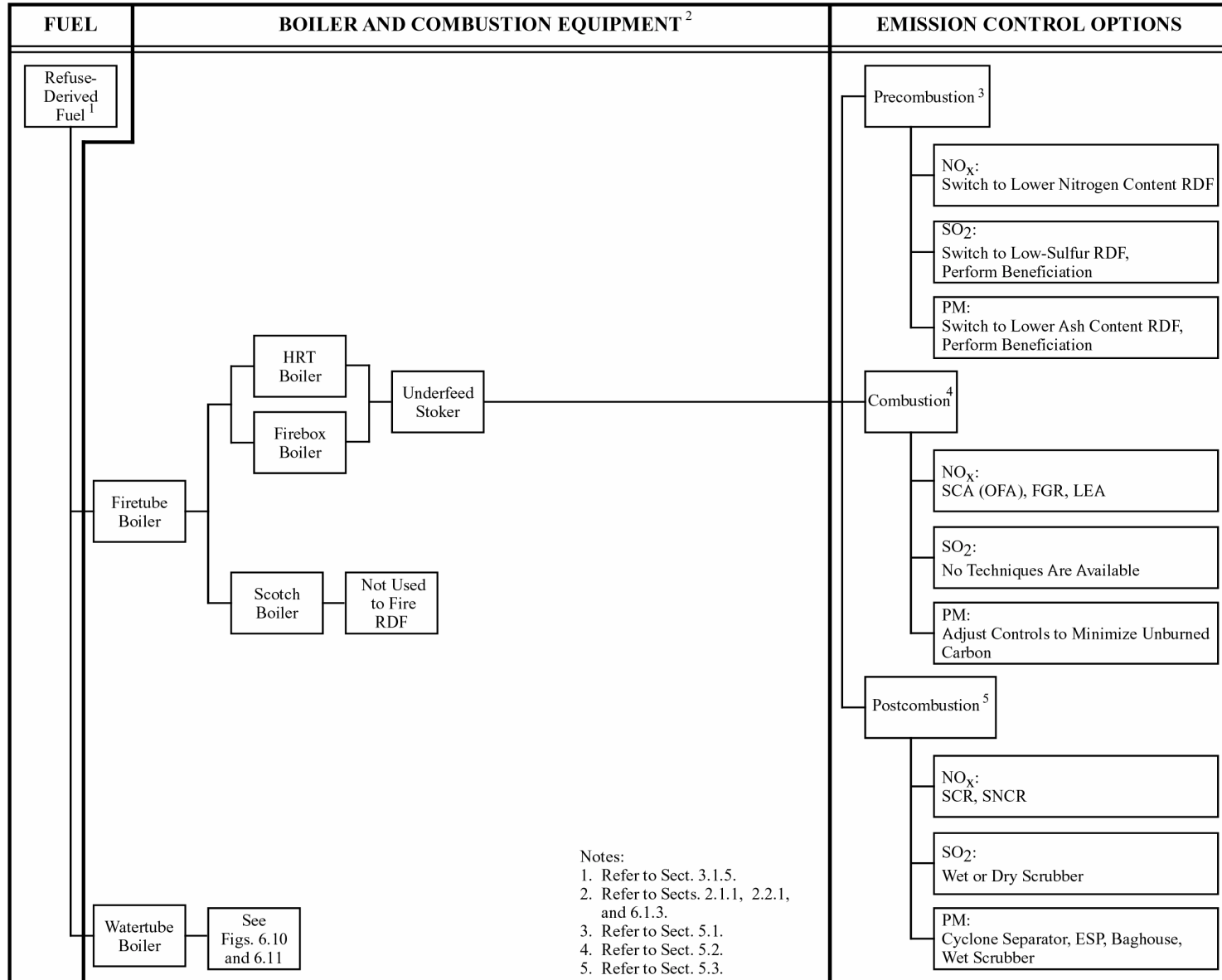

Fig. 6.12. Emission control options for RDF-fired, stoker-fed, firetube boilers.

6.2 EMISSION CONTROL EQUIPMENT

The performance objective for emission control equipment is to reduce NO_x, SO₂, CO, VOC, or PM emissions through the application of proven technology. Although some technologies are more effective than others, factors such as the type of boiler, the type of fuel, and the thermodynamic conditions inside the boiler strongly influence performance.

Selection of emission control equipment should begin with an evaluation of the facility. The focus of the evaluation is to determine the types of emissions that must be controlled so that candidate technologies for reducing the emissions can be identified. Applicable regulations may require technology equivalent to

- BACT
- LAER
- RACT

Technology-based regulations have been around for many years and have proven effective in reducing emissions. They are successful because reductions are based on application of technology rather than the direct specification of acceptable emission rates. By adopting this approach, regulatory authorities ensure that newly developed technologies are considered in the evaluation, and the best technologies are identified and implemented. New technologies are important because, in general, they provide greater reductions in emissions than current technologies.

As discussed in Sect. 4.1.4, BACT is applicable to new sources in attainment areas. It involves an evaluation of current emission control techniques to establish an acceptable emission limitation. When BACT is evaluated, the effectiveness of a control technology is measured against the cost of the technology. Each evaluation is performed on a case-by-case basis, taking into account energy, environmental, and economic impacts. In establishing BACT for a new source, cost is usually the driving factor. The cost of the emission control equipment is compared to the annual emission reduction to establish a cost factor in dollars per ton of pollutant removed. The following equation is sometimes used to compare the cost effectiveness of different technologies.

$$\frac{\text{Annual cost of control equipment}}{(\text{Uncontrolled emission rate}) - (\text{Controlled emission rate})} \quad (6.1)$$

Regulations requiring BACT set a maximum cost figure that the owner or operator can spend to meet local emission requirements. If the cost-effectiveness of the technology is above the figure, the technology is not required, and the next lower cost technology is evaluated. The process of reviewing each technology in decreasing order of cost is called top-down BACT. This process assures that the source achieves the lowest emission level within the required cost-effectiveness.

RACT is similar to BACT, but it only applies to existing sources. The cost requirements for RACT, which are intended to be available at a “reasonable” cost, are less than BACT. Many states with ozone NAAs set emission limitations from ICI boilers at levels that can be achieved through burning cleaner fuels (i.e., natural gas), using low-NO_x technologies, or a combination of both. When an owner or operator of an ICI boiler located in an ozone NAAs is establishing RACT, steps should be taken to understand the applicable RACT requirements.

Some regulations require that technology equivalent to LAER be utilized in new major sources located in NAAs. LAER is different from BACT because it has no economic justification associated with its requirements. LAER is the most stringent of all technology-based regulations. When required, technology equivalent to LAER must be used regardless of the cost.

Owners and operators can use the emission control options shown in Figs. 6.1–6.12 as a guide when performing BACT/RACT/LAER evaluations. Each emission control option should be considered so that

all applicable technologies that require evaluation are identified and none are overlooked. Additional information that can be useful in prioritizing the technologies for evaluation is provided in the remainder of this section.

6.2.1 Nitrogen Oxides Reduction

The NO_x emissions can sometimes be reduced by switching to a fuel with a lower nitrogen content. Although effective, emissions limitations often make it necessary to implement combustion or postcombustion NO_x control techniques.

As described in Sect. 5.2, commonly used combustion control techniques for reducing NO_x emissions include

- operational modifications
 - OT
 - BT
 - LEA
- SCA
 - BOOS
 - BF
 - OFA
- SI/WI
- FGR
- FIR
- RAP
- NGR

Another combustion control technique that is used routinely to reduce NO_x emissions involves the installation of LNBS. Many LNB designs incorporate techniques such as SCA and FGR. Emissions from natural-gas-fired boilers fitted with LNBS are often in the range of 0.01- to 0.04-lb/MBtu (10- to 30-ppm volumetric, corrected to 3% oxygen). Because of their effectiveness, LNBS are now considered standard for most new boilers that burn natural gas or fuel oil. Additional discussions about LNBS are provided in Sect. 5.2.1.5.

Current requirements for very low NO_x emissions from natural-gas-fired boilers have led to the development of ULNBS. These burners are capable of reducing NO_x emissions to below 30-ppm volumetric, corrected to 3% oxygen. Some of these burners are even capable of reducing NO_x emissions to less than 10-ppm volumetric, corrected to 3% oxygen (0.01 lb/MBtu). The manufacturer can provide helpful information about these burners and performance history data. Additional discussions about ULNBS are provided in Sect. 5.2.1.6.

Implementation of each emission control technique identified above typically results in a different degree of NO_x reduction. As an example, when firing natural gas, use of LEA typically reduces NO_x emissions by 10%, whereas use of FGR reduces NO_x emissions by up to 80% (Ref. 4). FGR is one of the most effective methods for reducing NO_x emissions from ICI boilers with heat input capacities less than 100 MBtu/h. Typical reductions for natural-gas-fired boilers are 45% with 10% recirculation and 75% reduction with 20% recirculation.⁴ Also, SI or WI can be effective in reducing NO_x emissions by 80%, but the cooling effect of the water can have an impact on boiler performance. There can be a thermal efficiency penalty if water or steam is injected in large quantities simply to reduce flame temperature, but that is typically not how this technique is used. Steam is commonly used to atomize fuel oil and increasingly used in small quantities with natural gas as one part of a comprehensive LNB strategy that employs staged combustion, FGR, and other techniques. Finally, all combustion modifications that reduce

flame temperature have the potential for decreasing thermal efficiency. Lowering the flame temperature will greatly reduce radiant heat transfer, which will not be recovered in the convection pass, and result in a large thermal efficiency penalty. As these examples illustrate, the effectiveness of a particular control technique depends on many factors.

A summary of the effectiveness of combustion control techniques in reducing NO_x emissions from firetube and watertube boilers that burn various fuels is presented in Tables 6.3 and 6.4, respectively. The data in these tables were compiled by EPA from published technical papers and EPA documents² and by ABMA.³ When values in these tables are considered, the data represent reductions based on technologies developed prior to the mid-1990s. Newer equipment developed in the last few years may exhibit even better performance.

When combustion controls do not provide the required level of NO_x reduction, it may be necessary to treat the flue gas before it is released into the atmosphere. Flue gas can be treated using either SCR or SNCR to reduce NO_x emissions. In the SCR technique, a reductant (ammonia gas) is injected in the flue-gas stream before it passes through a catalyst bed. The resulting reaction disassociates NO_x to nitrogen gas and water vapor. Depending on the catalyst, SCR can be used where exhaust gas temperatures range between 350 and 1,200°F. The SNCR technique involves injecting a reagent into the flue-gas stream where NO_x is reduced to nitrogen gas and water vapor. To be effective, the reagent must be injected at a location where the flue-gas temperature is approximately 1,400 to 1,600°F. Ammonia gas and aqueous urea are the two reagents most often used in the SNCR process. Although the designs of SCR and SNCR systems are somewhat different, major items to consider include space constraints, location of other equipment, temperature requirements, fuel, and cost. Use of SCR and SNCR to reduce NO_x emissions has proven very effective with reductions ranging between 20 and 90%. Data in Table 6.5, which were compiled by EPA and reported in 1994,² summarize NO_x control performance using these techniques for various ICI boiler applications. SCR and SNCR are the two most popular postcombustion NO_x control techniques in use so at least one of these techniques must be considered when low-NO_x combustion technology proves insufficient to meet emission requirements.

The cost-effectiveness of a particular NO_x control technique can vary widely. Environmental regulations are the single most important cost factor. These regulations drive equipment selection, along with commissioning and acceptance testing expenses. Equipment and operating costs are a function of design, fabrication, labor, material, fuel, electrical power, and transportation expenses. Accurate cost comparisons among alternative options can only be made on a case-by-case basis.

Table 6.3. Performance summary for NO_x control techniques on ICI firetube boilers

Boiler type and fuel	NO _x control technique	NO _x reduction (%)	Controlled NO _x level (lb/MBtu)
Residual oil	LNB	10–60	0.09–0.25
	FGR	10–20	
	SCA	0–49	
Distillate oil	LNB	10–20	0.15
	FGR	20–40	0.04–0.16
	SCA	0–10	
Natural gas	LNB	20–78	0.02–0.08
	FGR	40–76	0.02–0.08
	SCA	0–10	0–0.08
	LNB + FGR	30–80	0.02–0.04

Source: Refs. 2 and 3.

Table 6.4. Performance summary for NO_x control techniques on ICI watertube boilers

Boiler type and fuel	NO _x control technique	NO _x reduction (%)	Controlled NO _x level (lb/MBtu)
PC, wall-fired	SCA	15–39	0.33–0.93
	LNB	49–67	0.26–0.50
	LNB + SCA	42–66	0.24–0.49
PC, tangential-fired	SCA	25	0.29–0.38
	LNB	18	0.36
	LNB + SCA	55	0.20
Spreader stoker	SCA	6–35	0.31–0.52
	FGR + SCA	0–60	0.19–0.47
	RAP	32	0.30
Coal-fired, FBC (bubbling bed)	SCA	–	0.10–0.14
Coal-fired, FBC (circulating bed)	SCA	–	0.05–0.45
	SCA + FGR	–	0.12–0.16
Residual oil	LNB	10–60	0.09–0.60
	FGR	4–30	0.12–0.35
	SCA	0–60	0.20–0.74
	LNB + FGR	–	0.10–0.55
	LNB + SCA	–	0.20–0.40
Distillate oil	LNB	10–40	0.08–0.33
	FGR	20–68	0.04–0.30
	SCA	0–40	0.09–0.30
	LNB + FGR	–	0.03–0.25
	LNB + SCA	–	0.10–0.30
Natural gas	LNB	0–71	0.03–0.20
	FGR	40–74	0.02–0.10
	SCA	0–60	0.06–0.24
	LNB + FGR	55–84	0.02–0.20
	LNB + SCA	30–80	0.10–0.20

Source: Refs. 2 and 3.

In making cost comparisons, the following should be considered:

1. In general, costs increase as required emission levels are reduced.
2. The higher costs of cleaner burning fuels should be evaluated against the lower level of required emission reduction and the lower cost of the required technology. Conversely, the lower cost of dirtier burning fuels should be evaluated against the higher level of required emission reduction and the higher cost of the required technology.
3. In cases in which rear-end cleanup is mandatory because of required emission levels, the use of the lower level of burner technology at a lower cost should be evaluated in combination with a higher level of rear-end emission reduction and vice-versa.
4. Driving emissions lower in one area (e.g., NO_x) can increase emissions in other areas (e.g., CO), which may increase total costs.
5. Boiler load following capability may become more constrained with ULNBs.

Table 6.5. Performance summary for NO_x flue-gas treatment techniques on ICI boilers

Fuel and boiler type	NO _x control technique	NO _x reduction (%)	Controlled NO _x level (lb/MBtu)
PC, wall-fired	SNCR-urea	30–83	0.15–0.40
MSW-fired, stoker	SNCR-urea	41–75	0.062–0.30
Coal-fired, stoker	SNCR-ammonia	50–66	0.15–0.18
	SNCR-urea	40–74	0.14–0.28
Wood-fired, stoker	SNCR-ammonia	50–80	0.035–0.23
	SNCR-urea	25–78	0.084–0.17
Coal-fired, FBC	SNCR-ammonia	30–65	0.04–0.087
	SNCR-urea	57–88	0.028–0.14
	SCR	53–63	0.10–0.15
Wood-fired, FBC	SNCR-ammonia	44–80	0.035–0.20
	SNCR-urea	60–70	0.063–0.07
Wood-fired, watertube	SNCR-urea	50	0.24–0.26
	SCR	80	0.22
Fuel oil or natural gas-fired, watertube	SNCR-ammonia	30–72	0.03–0.20
	SNCR-urea	50–60	0.049–0.13
	SCR	53–90	0.011–0.055
Fuel oil or natural gas-fired, firetube	SCR	53–91	0.006–0.05

Source: Ref. 2.

6.2.2 Sulfur Dioxide Reduction

Except for FBC boilers, which are capable of removing sulfur during combustion, there are two fundamental strategies for reducing SO₂ emissions. They involve switching to lower sulfur content fuel and installing scrubbers to treat the flue gas. For most large utility boilers that burn coal, switching to low-sulfur coal has been effective. However, compliance with more stringent SO₂ emission limitations generally requires installation of scrubbers.

Wet and dry scrubbers have been used for many years to remove SO₂ from flue-gas streams. Both of these FGD techniques are popular because they are very effective. Although wet and dry scrubbers are distinctively different in their design and operation, they both involve chemical reactions that transform gaseous SO₂ into either liquid or solid sulfur-bearing compounds. Flue gas scrubbers that effectively reduce SO₂ emissions are often described as complex chemical plants. Additional discussions about wet and dry FGD techniques are provided in Sect. 5.3.2.

During the wet scrubbing process, the flue gas is contacted with an aqueous slurry of lime, limestone, or another alkali material. The slurry reacts with SO₂ to form calcium salts. Because of the presence of excessive amounts of moisture, wet scrubbers are placed downstream of the PM collection system. Wet scrubbers have been used since about 1970 predominantly by utilities that burn coal. Several wet FGD systems are in commercial use with SO₂ removal efficiencies as high as 90% (Ref. 6). Use of wet scrubbers offers several advantages. They provide an alternative to fuel switching, the SO₂ removal efficiency is very good, and reagent utilization is high.

The process of dry scrubbing involves spraying a highly atomized slurry or aqueous solution of an alkaline reagent into the hot flue gas to absorb the SO₂. Dry scrubbers are the principal alternative to wet scrubbers for utility boiler applications. For smaller boilers, dry scrubbers are a popular choice because they are less costly to construct, the waste product is dry, there are fewer unit operations, and the operations are simpler. Unlike wet scrubbers, which require excessive amounts of moisture, dry scrubbers may be positioned before the PM collection system.

For ICI boiler applications, the most cost-effective way to reduce SO₂ emissions usually involves switching to a lower sulfur content fuel. Fuels such as natural gas, distillate oil, low-sulfur residual oil, RDF, and most biomass typically have lower sulfur contents than coal and residual oil. When a scrubber for an ICI boiler is required, a lime dry scrubber is often the most economical option.

6.2.3 Particulate Matter Reduction

Current emission regulations require control of PM emissions whenever virtually all fuels except natural gas and selected fuel oils are burned. Methods for reducing PM emissions vary, depending on the type of boiler and the size of the particles that are produced. For small boilers, the most cost-effective approach often involves switching from high-ash content fuels such as coal and residual oil to alternative fuels like distillate oil or natural gas. For larger boilers, techniques for controlling PM emissions typically involve the use of cyclone separators, ESPs, scrubbers, and baghouses (fabric filters).

Mechanical collectors such as cyclone separators are effective at removing large particles (greater than about 10 μm), but collection efficiency drops significantly as the particle size decreases. These collectors were adequate when emissions regulations were less stringent and when popular firing techniques produced larger particles. Use of cyclones in new combustion applications is primarily limited to FBC boilers.⁵ When cyclones are used, it may be advantageous to consider reinjecting the collected particles back into the combustion zone. Reinjection can be an effective technique for reducing PM emissions by some level and for reducing carbon loss and thereby increasing combustion efficiency. However, note that another type of PM collector such as an ESP or a fabric filter must be installed in series with the cyclone to meet PM emission limitations.

ESPs are capable of removing very fine particles from a flue-gas stream. For coal-fired boilers that burn coals with medium- to high-ash contents, ESPs are capable of reducing PM emissions by 99.9% or more. Although ESPs represent proven technology that has been used for many years, they are not well suited for all boiler applications, especially when adequate space to house the necessary components and ductwork is not available. Advantages of an ESP are high total collection efficiency, high reliability, low flue-gas pressure loss, resistance to moisture and temperature upsets, and low maintenance.⁵ When ESPs are considered for biomass-fired boilers, note that there is a potential for fires to occur in the precipitator housing because of the high carbon content of the fly ash.

Well designed fabric filters or baghouses are also very effective. Reductions in PM emissions are often greater than 99.9%. However, like ESPs, space constraints can prevent the use of baghouses. Advantages of fabric filters include high collection efficiency throughout the particle size range, high reliability, resistance to flow upsets, little impact of ash chemical constituents on performance, good dustcake characteristics, and dry acid gas removal. In applications where small particles dominate, fabric filters are the preferred choice for maximum control if a condition known as bag blinding can be avoided.⁵ For boilers that burn RDF, the preferred emission control system includes a dry scrubber and baghouse combination. The dry scrubber effectively controls dioxin, furan, and heavy-metal emissions, and the baghouse controls PM emissions. Because of the potential for fire in the baghouse, fabric filters are usually not suitable for biomass-fired boilers.

Wet scrubbers, which are used primarily to reduce SO₂ emissions, are sometimes used to remove PM from a flue-gas stream. Although wet scrubbers offer an alternative to cyclone separators, ESPs, and baghouses, they are seldom used as the primary particulate collection device. In addition, factors such as collection efficiency, dust particle size, and gas pressure drop represent closely related parameters that can impact boiler performance. Because of excessive pressure drop, larger fan capacity is generally required in applications where wet scrubbers are installed.

Selecting a suitable PM control technique that is cost-effective often requires careful comparisons of various options. For applications where ESPs and fabric filters are technically acceptable and high collection efficiencies are required, the following guidelines are provided:

- on small units, a pulse jet fabric filter is frequently the preferred choice;
- on larger units with medium or high sulfur coal, ESPs are often more attractive; and
- on large low-sulfur coal-fired units, a reverse air fabric filter may prove to be an economical option.⁵

Additional discussions about techniques for controlling PM emissions that may help owners and operators make informed selection decisions are presented in Sect. 5.3.3.

6.3 SYSTEM CONFIGURATION

Selection of a low-emission boiler and combustion equipment should not be finalized until the performance of the complete system is evaluated and understood. Besides the combustion and emission control components previously discussed, it is often necessary to include other devices such as air heaters and economizers in the system. These devices, which are designed to recover the low-temperature energy from the flue gas, are sometimes required to improve overall thermal efficiency. Economizers use recovered energy to heat the boiler feedwater, while air heaters use the energy to heat the combustion air. Air heating also enhances the combustion of many fuels and is critical for PC firing for drying the coal and ensuing stable ignition. Use and arrangement of air heaters and economizers depends on factors such as the fuel characteristics, combustion process, boiler operating pressure, power cycle, and overall cost.⁵ To function satisfactorily, all of the selected components must not only fit together, but they must also provide the required levels of emission reduction without significantly impacting boiler efficiency.

A very important system consideration that requires careful attention involves the arrangement of the emission control equipment located between the boiler and the stack. As an example, Fig. 6.13 shows four different equipment configurations that are each capable of controlling PM, NO_x, and SO₂ emissions. Although it may be possible to adequately control emissions with the equipment arranged in these configurations, capital and operating costs associated with each arrangement are significantly different.

In general, Configuration 1 is preferred for most new solid fuel-fired boiler installations where space is unlimited. It provides the optimum temperature profile with least impact on boiler performance.⁵ Depending on local conditions and site-specific design requirements, Configurations 2 and 3 may represent preferred arrangements for some boiler installations. Configuration 4 is well-suited for applications where space is limited. However, its capital and operating costs are substantially higher than those for Configuration 1. This difference in cost is attributed to the additional heat exchangers and duct burners that are required to adequately control the temperature of the flue gas.

Evaluations of different emission control equipment arranged in various configurations are technically complex, but they are now an essential element of the permitting process. Details of the evaluations often establish the technical basis for permit applications.

Depending on applicable environmental regulations, owners and operators are generally required to submit results of top-down BACT, RACT assessments, or LAER determinations to the regulatory authority for review. Unless these evaluations are accurate and complete and unless currently accepted techniques for controlling emissions are adequately taken into consideration, it is unlikely that the regulatory authority will act favorably on the application. Therefore, it is in the owner's or operator's best interest to consider all options for controlling emissions and select the ones that best address the concerns and requirements of the regulatory authority. As discussed in Sect. 4.3, any delays in the permitting process that result from inadequate or incomplete evaluations waste valuable time and money by extending the construction start date.

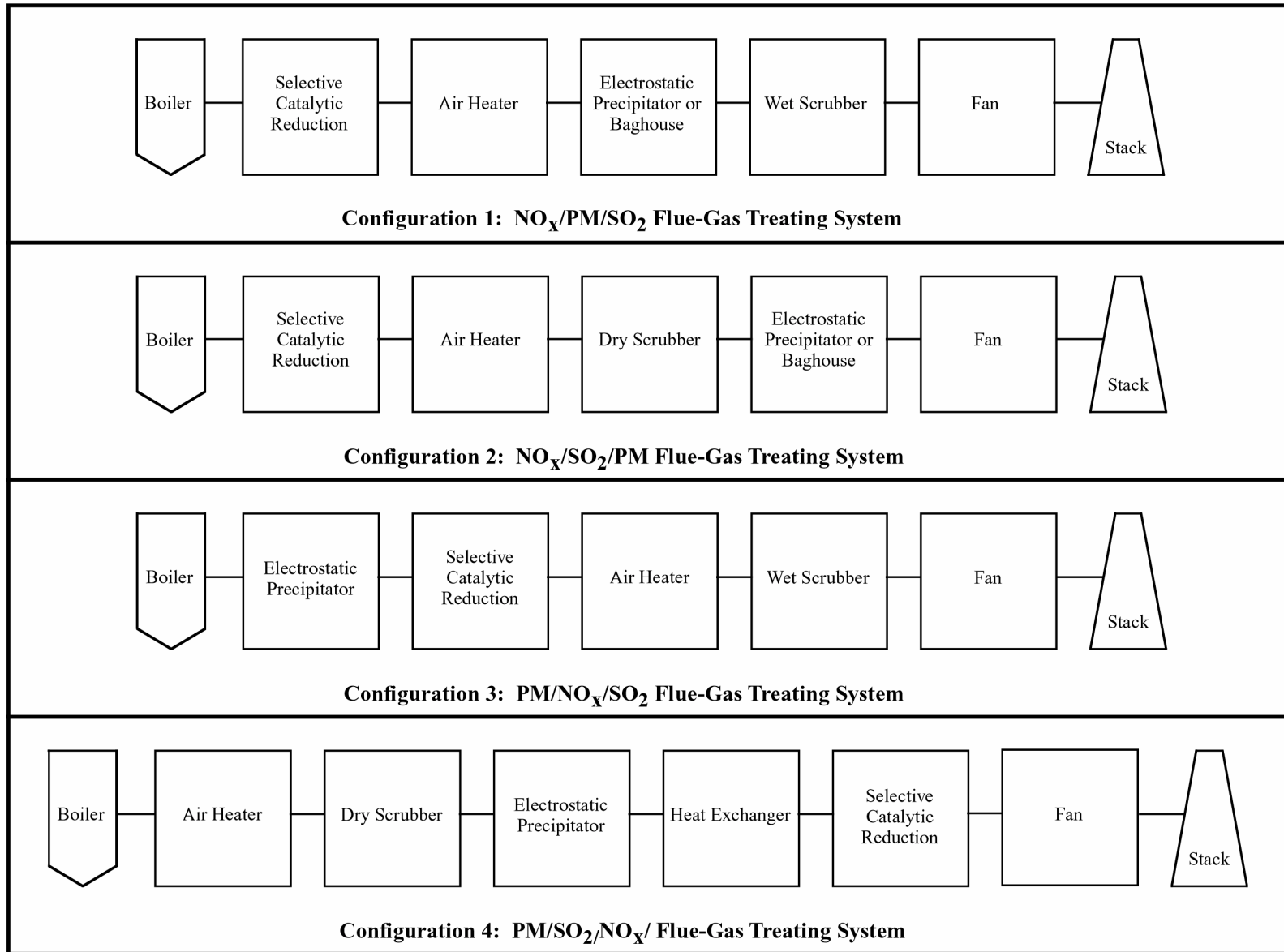

Fig. 6.13. Examples of flue-gas treating system configurations for solid-fuel-fired boilers.

6.4 REFERENCES

1. *Combustion Fossil Power*, 4th ed., ed. J. G. Singer, Combustion Engineering, Inc., Windsor, Connecticut, 1991.
2. *Alternative Control Techniques Document—NO_x Emissions from Industrial/Commercial/Institutional (ICI) Boilers*, EPA-453/R-94-022, U.S. Environmental Protection Agency, March 1994.
3. *Guideline for Gas and Oil Emission Factors for Industrial, Commercial, and Institutional (ICI) Boilers*, American Boiler Manufacturers Association, Arlington, Virginia, 1997.
4. *Boiler Emissions Reference Guide*, 2nd ed., Cleaver-Brooks, Milwaukee, Wisconsin, January 1994.
5. *Steam, Its Generation and Use*, 40th ed., ed. S. C. Stultz and J. B. Kitto, Babcock and Wilcox, Barberton, Ohio, 1992.
6. *SO₂ Removal Using Gas Suspension Absorption Technology*, Topical Report No. 4, Clean Coal Technology, U.S. Department of Energy, April 1995.

SELECTED BIBLIOGRAPHY

- A Guide to Clean and Efficient Operation of Coal-Stoker-Fired Boilers*, American Boiler Manufacturers Association, Arlington, Virginia, 2002.
- “Acid Rain Nitrogen Oxides Emission Reduction Program,” 40 CFR 76, U.S. Environmental Protection Agency.
- “Acid Rain Program; Nitrogen Oxides Emission Reduction Program; Final Rule,” *Federal Register*, **61**, No. 245, 67111-67164, December 19, 1996.
- Advanced Technologies for the Control of Sulfur Dioxide Emissions from Coal-Fired Boilers*, Topical Report No. 12, Clean Coal Technology, U.S. Department of Energy, June 1999.
- Air Pollution Operating Permit Program Update, Key Features and Benefits*, EPA/451/K-98/002, U.S. Environmental Protection Agency, February 1998.
- Alternative Control Techniques Document—NO_x Emissions from Industrial/Commercial/Institutional (ICI) Boilers*, EPA-453/R-94-022, U.S. Environmental Protection Agency, March 1994.
- Analysis of the Industrial Boiler Population*, Topical Report GRI-96/0200, prepared by Energy and Environmental Analysis, Inc., for the Gas Research Institute, Chicago, Illinois, June 1996.
- “Appeal Procedures for Acid Rain Program,” 40 CFR 78, U.S. Environmental Protection Agency.
- Barr, M. R., “What 15,000+ Permits and Permit Modifications Have Taught Us,” presented at the CIBO NO_x Control XIV Conference, San Diego, California, March 13, 2001.
- Basu, P., Kefa, C., and Jestin, L., *Boilers and Burners: Design and Theory*, Springer, New York, 2000.
- Boiler and Combustion Systems Hazards Code*, NFPA 85, National Fire Protection Association, Quincy, Massachusetts, 2001.
- Boiler Emissions Reference Guide*, 2nd ed., Cleaver-Brooks, Milwaukee, Wisconsin, January 1994.
- Boiler NO_x Control Field Manual*, American Gas Association, Baltimore, Maryland, November 1994.
- “Clean Air Act,” U.S. Environmental Protection Agency, <http://www.epa.gov/oar/caa/contents.html>
- Combustion Control Guidelines for Single Burner Firetube and Watertube Industrial/Commercial/Institutional Boilers*, American Boiler Manufacturers Association, Arlington, Virginia, 1999.
- Combustion Control Guidelines for Multiple Burner Boilers*, American Boiler Manufacturers Association, Arlington, Virginia, 2002.
- Combustion Fossil Power*, 4th ed., ed. J. G. Singer, Combustion Engineering, Inc., Windsor, Connecticut, 1991.
- Commercial/Industrial Gas and/or Oil-Burning Assemblies with Emission Reduction Equipment*, UL 2096, 2nd ed., Underwriters Laboratories, Inc., Northbrook, Illinois, 1999.
- “Compilation of Air Pollutant Emission Factors,” AP-42, 5th ed., Vol. I, *Stationary Point and Area Sources*, U.S. Environmental Protection Agency, January 1995. <http://www.epa.gov/ttn/chief/ap42/>
- “Compilation of Air Pollutant Emission Factors,” AP-42, 5th ed., Vol. I, *Stationary Point and Area Sources*, Chap. 1, U.S. Environmental Protection Agency, January 1995. <http://www.epa.gov/ttn/chief/ap42/>
- “Continuous Emissions Monitoring,” 40 CFR 75, U.S. Environmental Protection Agency.
- Control of Nitrogen Dioxide Emissions: Selective Catalytic Reduction (SCR)*, Topical Report No. 9, Clean Coal Technology, U.S. Department of Energy, July 1997.
- Controls and Safety Devices for Automatically Fired Boilers*, CSD-1, American Society of Mechanical Engineers, New York, 1998.
- “Determination of Nitrogen Oxide Emissions from Stationary Sources—Ion Chromatographic Method,” Method 7A, 40 CFR 60, Appendix A, U.S. Environmental Protection Agency, 1999.
- “Determination of Nitrogen Oxide Emissions from Stationary Sources—Alkaline-Permanganate/Colorimetric Method,” Method 7C, 40 CFR 60, Appendix A, U.S. Environmental Protection Agency, 1999.

- “Determination of Nitrogen Oxide Emissions from Stationary Sources—Alkaline-Permanganate/Ion Chromatographic Method,” Method 7D, 40 CFR 60, Appendix A, U.S. Environmental Protection Agency, 1999.
- “Determination of Nitrogen Oxide Emissions from Stationary Sources (Instrumental Analyzer Procedure),” Method 7E, 40 CFR 60, Appendix A, U.S. Environmental Protection Agency, 1999.
- “Determination of Nitrogen Oxides Emissions from Stationary Sources,” Method 7, 40 CFR 60, Appendix A, U.S. Environmental Protection Agency, 1999.
- “Determination of Nonsulfuric Acid Particulate Matter from Stationary Sources,” Method 5B, 40 CFR 60, Appendix A, U.S. Environmental Protection Agency, 1999.
- “Determination of Particulate Emissions from Stationary Sources (Instack Filtration Method),” Method 17, 40 CFR 60, Appendix A, U.S. Environmental Protection Agency, 1999.
- “Determination of Particulate Emissions from Stationary Sources,” Method 5, 40 CFR 60, Appendix A, U.S. Environmental Protection Agency, 1999.
- “Determination of Sulfur Dioxide and Carbon Dioxide Daily Average Emissions from Fossil Fuel Combustion Sources,” Method 6B, 40 CFR 60, Appendix A, U.S. Environmental Protection Agency, 1999.
- “Determination of Sulfur Dioxide Emissions from Stationary Sources,” Method 6, 40 CFR 60, Appendix A, U.S. Environmental Protection Agency, 1999.
- “Determination of Sulfur Dioxide Emissions from Stationary Sources (Instrumental Analyzer Procedure),” Method 6C, 40 CFR 60, Appendix A, U.S. Environmental Protection Agency, 1999.
- “Determination of Sulfur Dioxide Removal Efficiency and Particulate Matter, Sulfur Dioxide, and Nitrogen Oxides Emissions Rates,” Method 19, 40 CFR 60, Appendix A, U.S. Environmental Protection Agency, 1999.
- “Determination of Sulfur Dioxide, Moisture, and Carbon Dioxide Emissions from Fossil Fuel Combustion Sources,” Method 6A, 40 CFR 60, Appendix A, U.S. Environmental Protection Agency, 1999.
- Dockrill, P., and Friedrich, F., *Boilers and Heaters: Improving Energy Efficiency*, CANMET Energy Technology Centre, Nepean, Ontario, Canada, August 2001.
- Dukelow, S. G., *The Control of Boilers*, The Instrumentation, Systems, and Automation Society, Research Triangle Park, North Carolina, 1991.
- Elliott, T. C., *Standard Handbook of Powerplant Engineering*, McGraw-Hill Publishing Company, New York, 1989.
- Energy Efficiency Handbook*, ed. R. A. Zeitz, Council of Industrial Boiler Owners, Burke, Virginia, November 1997.
- EPA National Publications Catalog*, EPA 200-B-00-001, U.S. Environmental Protection Agency, July 2000.
- “Excess Emissions,” 40 CFR 77, U.S. Environmental Protection Agency.
- “Federal NO_x Budget Trading Program,” 40 CFR 97, U.S. Environmental Protection Agency.
- “Federal Operating Permit Programs,” 40 CFR 71, U.S. Environmental Protection Agency.
- Final Revisions to the Ozone and Particulate Matter Air Quality Standards*, EPA-456/F-97-004, U.S. Environmental Protection Agency, July 1997.
- “Finding of Significant Contribution and Rulemaking for Certain States in the Ozone Transport Assessment Group Region for Purposes of Reducing Regional Transport of Ozone; Rule,” *Federal Register*, **63**, No. 207, 57355-57404, October 27, 1998.
- “Findings of Significant Contribution and Rulemaking on Section 126 Petitions for Purposes of Reducing Interstate Ozone Transport; Final Rule,” *Federal Register*, **64**, No. 100, 28249-28328, May 25, 1999.
- “Findings of Significant Contribution and Rulemaking on Section 126 Petitions for Purposes of Reducing Interstate Ozone Transport,” *Federal Register*, **65**, No. 11, 2654-2703 January 18, 2000.

Garner, L., *Experience with Low NO_x Burners*, IEACR/99, IEA Coal Research, London, United Kingdom, November 1997.

Govan, F. A., *Permitting Requirements for Industrial, Commercial, and Institutional Boilers*, Pendent Media, Inc., Cleveland, Ohio, November 2000.

Guideline for Gas and Oil Emission Factors for Industrial, Commercial, and Institutional (ICI) Boilers, American Boiler Manufacturers Association, Arlington, Virginia, 1997.

Guidelines for Boiler Control Systems (Gas/Oil Fired Boilers), American Boiler Manufacturers Association, Arlington, Virginia, 1998.

Guidelines for Burner Adjustments of Commercial Oil-Fired Boilers, American Boiler Manufacturers Association, Arlington, Virginia, 1996.

Guidelines for Industrial Boiler Performance Improvement, American Boiler Manufacturers Association, Arlington, Virginia, 1999.

Handbook of Energy Systems Engineering, ed. L. C. Wilbur, John Wiley & Sons, Inc., New York, 1985.

Harrell, G., *Steam System Survey Guide*, ORNL/TM-2001/263, Oak Ridge National Laboratory, Oak Ridge, Tennessee, 2002.

Krolewski, M. J., and Mingst, A. S., "Recent NO_x Reduction Efforts: An Overview," ICAC Forum 2000, U.S. Environmental Protection Agency.

Lunt, R. R., and Cunic, J. D., *Profiles in Flue Gas Desulfurization*, American Institute of Chemical Engineers, New York, New York, 2000.

"National Board Inspection Code," NB-23, National Board of Boiler and Pressure Vessel Inspectors, Columbus, Ohio, 2001.

"National Fuel Gas Code," NFPA 54, National Fire Protection Association, Quincy, Massachusetts, 1999.

Nitrogen Oxides (NO_x), Why and How They are Controlled, EPA 456/F-99-006R, U.S. Environmental Protection Agency, November 1999.

North American Combustion Handbook, Volume 1: Combustion, Fuels, Stoichiometry, Heat Transfer, Fluid Flow, 3rd ed., North American Manufacturing Company, Cleveland, Ohio, 1986.

"NO_x Budget Trading Program for State Implementation Plans," 40 CFR 96, U.S. Environmental Protection Agency.

Oegema, R., "SCONOX™ Emissions Control Technology in the Industrial Sector," presented at the CIBO NO_x Control XIV Conference, San Diego, California, March 13, 2001.

Our Boilers & Environmental Equipment, E101-3216C, Babcock and Wilcox Company, Barberton, Ohio, 1998.

Packaged Boiler Engineering Manual, 2nd ed., American Boiler Manufacturers Association, Arlington, Virginia, 1998.

"Permit Requirements," 40 CFR 51.165, U.S. Environmental Protection Agency.

"Permits Regulation," 40 CFR 72, U.S. Environmental Protection Agency.

"Prevention of Significant Deterioration of Air Quality," 40 CFR 52.21, U.S. Environmental Protection Agency.

"Primary and Secondary National Ambient Air Quality Standards," 40 CFR 50, U.S. Environmental Protection Agency.

Rabovitser, J. K., and Cygan, D. F., *Demonstration of Forced Internal Recirculation (FIR) Burner for Firetube Boilers*, GRI-00/0105, Gas Research Institute, Chicago, Illinois, June 2000.

RACT/BACT/LAER Clearinghouse Clean Air Technology Center Annual Report for 1999, A Compilation of Control Technology Determinations Ninth Supplement to 1999 Edition, EPA 456/R-99-004, U.S. Environmental Protection Agency, June 1999.

Reburning Technologies for the Control of Nitrogen Oxides Emissions from Coal-Fired Boilers, Topical Report No. 14, Clean Coal Technology, U.S. Department of Energy, May 1999.

Reducing Emissions of Nitrogen Oxides via Low-NO_x Burner Technologies, Topical Report No. 5, Clean Coal Technology, U.S. Department of Energy, September 1995.

- Reduction of NO_x and SO₂ Using Gas Reburning, Sorbent Injection, and Integrated Technologies*, Topical Report No 3, Rev. 1, U.S. Department of Energy, September 1993.
- “Revision of Standards of Performance for Nitrogen Oxide Emissions From New Fossil-Fuel Fired Steam Generating Units; Revisions to Reporting Requirements for Standards of Performance for New Fossil-Fuel Fired Steam Generating Units,” *Federal Register*, **63**, No. 179, 49442-49455, September 16, 1998.
- “Rules for Construction of Heating Boilers,” Section IV, *ASME Boiler and Pressure Vessel Code*, American Society of Mechanical Engineers, New York, 1998.
- “Rules for Construction of Power Boilers,” Section I, *ASME Boiler and Pressure Vessel Code*, American Society of Mechanical Engineers, New York, 1998.
- SO₂ Removal Using Gas Suspension Absorption Technology*, Topical Report No. 4, Clean Coal Technology, U.S. Department of Energy, April 1995.
- Soud, H. N., *Suppliers of FGD and NO_x Control Systems*, IEACR/83, IEA Coal Research, London, United Kingdom, November 1995.
- Soud, H. N., and Fukasawa, K., *Developments in NO_x Abatement and Control*, IEACR/89, IEA Coal Research, London, United Kingdom, August 1996.
- Soud, H. N., and Mitchell, S. C., *Particulate Control Handbook for Coal-Fired Plants*, IEACR/93, IEA Coal Research, London, United Kingdom, July 1997.
- “Standard Classification of Coal by Rank,” ASTM D 388, American Society for Testing and Materials, West Conshohocken, Pennsylvania, 1999.
- “Standard for Safety for Field Erected Boiler Assemblies,” UL 2106, 1st ed., Underwriters Laboratories, Inc., Northbrook, Illinois, 1994.
- “Standard for Safety for Oil Burners,” UL 296, 9th ed., Underwriters Laboratories, Inc., Northbrook, Illinois, 1994.
- “Standard for Safety for Oil-Fired Boiler Assemblies,” UL 726, 7th ed., Underwriters Laboratories, Inc., Northbrook, Illinois, 1995.
- “Standard for the Installation of Oil-Burning Equipment,” NFPA 31, National Fire Protection Association, Quincy, Massachusetts, 1997.
- “Standard for the Qualification and Certification of Operators of High Capacity Fossil Fuel Fired Plants,” ASME QFO-1-1998, American Society of Mechanical Engineers, New York.
- “Standard for the Qualification and Certification of Resource Recovery Facility Operators,” ASME QRO-1-1994, American Society of Mechanical Engineers, New York.
- “Standard Specification for Coal Fly Ash and Raw or Calcined Natural Pozzolan for Use as a Mineral Admixture in Concrete,” ASTM C 618, American Society for Testing and Materials, West Conshohocken, Pennsylvania, 1999.
- “Standard Specification for Fuel Oils,” ASTM D 396, American Society for Testing and Materials, West Conshohocken, Pennsylvania, 1998.
- “Standard Specification for Liquefied Petroleum (LP) Gases,” ASTM D 1835, American Society for Testing and Materials, West Conshohocken, Pennsylvania, 1997.
- “Standard Terminology of Coal and Coke,” ASTM D 121, American Society for Testing and Materials, West Conshohocken, Pennsylvania, 1999.
- “Standard Test Method for Ash in the Analysis Sample of Coal and Coke from Coal,” ASTM D 3174, American Society for Testing and Materials, West Conshohocken, Pennsylvania, 1997.
- “Standard Test Method for Determination of Nitrogen Oxides, Carbon Monoxide, and Oxygen Concentrations in Emissions from Natural Gas-Fired Reciprocating Engines, Combustion Turbines, Boilers, and Process Heaters Using Portable Analyzers,” ASTM D 6522, American Society for Testing and Materials, West Conshohocken, Pennsylvania, 2000.
- “Standard Test Method for Gross Caloric Value of Coal and Coke,” ASTM D 5865, American Society for Testing and Materials, West Conshohocken, Pennsylvania, 1999.

“Standard Test Method for Moisture in the Analysis Sample of Coal and Coke,” ASTM D 3173, American Society for Testing and Materials, West Conshohocken, Pennsylvania, 1996.

“Standard Test Method for Oxides of Nitrogen in Gaseous Products (Phenol-Disulfonic Acid Procedures),” ASTM D 1608, American Society for Testing and Materials, West Conshohocken, Pennsylvania, 1998.

“Standard Test Method for Total Moisture in Coal,” ASTM D 3302, American Society for Testing and Materials, West Conshohocken, Pennsylvania, 1999.

“Standard Test Method for Total Sulfur in the Analysis Sample of Coal and Coke,” ASTM D 3177, American Society for Testing and Materials, West Conshohocken, Pennsylvania, 1997.

“Standards of Performance for Electric Utility Steam Generating Units for Which Construction is Commenced After September 18, 1978,” 40 CFR 60, Da, U.S. Environmental Protection Agency.

“Standards of Performance for Fossil-Fuel-Fired Steam Generating Units for Which Construction is Commenced After August 17, 1971,” 40 CFR 60, D, U.S. Environmental Protection Agency.

“Standards of Performance for Industrial-Commercial-Institutional Steam Generating Units,” 40 CFR 60, Db, U.S. Environmental Protection Agency.

“Standards of Performance for Large Municipal Waste Combustors for Which Construction is Commenced After September 20, 1994, or for Which Modification or Reconstruction is Commenced After June 19, 1996,” 40 CFR 60, Eb, U.S. Environmental Protection Agency.

“Standards of Performance for Small Industrial-Commercial-Institutional Steam Generating Units,” 40 CFR 60, Dc, U.S. Environmental Protection Agency.

“State Operating Permit Programs,” 40 CFR 70, U.S. Environmental Protection Agency.

Steam, Its Generation and Use, 40th ed., ed. S. C. Stultz and J. B. Kitto, Babcock and Wilcox, Barberton, Ohio, 1992.

“Sulfur Dioxide Allowance System,” 40 CFR 73, U.S. Environmental Protection Agency.

“Sulfur Dioxide Opt-Ins,” 40 CFR 74, U.S. Environmental Protection Agency.

Sullivan, J. D., and Webb, A., *Development of the Radiation Stabilized Distributed Flux Burner*, DOE/ID/1332, U.S. Department of Energy, December 1999.

Takeshita, M., and Soud, H., *FGD Performance and Experience on Coal-Fired Plants*, IEACR/58, IEA Coal Research, London, United Kingdom, July 1993.

Taplin, H., *Combustion Efficiency Tables*, The Fairmont Press, Inc., Lilburn, Georgia, 1991.

“Technical Amendment to the Finding of Significant Contribution and Rulemaking for Certain States in the Ozone Transport Assessment Group Region for Purposes of Reducing Regional Transport of Ozone,” *Federal Register*, **65**, No. 42, 11222–11231, March 2, 2000.

Technologies for the Combined Control of Sulfur Dioxide and Nitrogen Oxides Emissions from Coal-Fired Boilers, Topical Report No. 13, Clean Coal Technology, U.S. Department of Energy, May 1999.

Technology Transfer Network Web, EPA-456/F-98-003, U.S. Environmental Protection Agency, July 1998.

“The Clean Air Act Amendments of 1990 Overview,” U.S. Environmental Protection Agency, <http://www.epa.gov/oar/caa/overview.txt>

The Clean Air Amendments Act: Updated Strategies, TRC Environmental Corporation, Windsor, Connecticut, and Hale and Door, Washington, D.C., 1994.

The Plain English Guide to the Clean Air Act, EPA-400-K-93-001, U.S. Environmental Protection Agency, April 1993.

Webster, T., “Burner Technology for Single Digit NO_x Emissions in Boiler Applications,” presented at the CIBO NO_x Control XIV Conference, San Diego, California, March 13, 2001.

Woodruff, E. B., Lammers, H. B., and Lammers, T. F., *Steam Plant Operation*, 7th ed., McGraw-Hill Companies, Inc., New York, 1998.

Wulfinghoff, D. A., *Energy Efficiency Manual*, Energy Institute Press, Wheaton, Maryland, 1999.

GLOSSARY

Area source: Any small source of nonnatural air pollution that is released over a small area but that cannot be classified as a point source. Such sources may include vehicles, fireplaces, woodstoves, and small fuel combustion engines.

Attainment area: An area considered to have air quality as good as or better than the National Ambient Air Quality Standards as defined in the Clean Air Act. An area may be an attainment area for one pollutant and a nonattainment area for others.

Best Available Control Technology (BACT): Emission control technology based on the maximum degree of emission reduction (considering energy, environmental, and economic impacts and other costs) achievable through application processes and available methods, systems, and techniques. Use of BACT is permitted by the authority having jurisdiction on a case-by-case basis for major new or modified emissions sources in attainment areas and applies to each regulated pollutant. In no event does the use of BACT permit emissions in excess of those allowed under any applicable Clean Air Act provisions.

Bias firing (BF): Biased firing involves injecting more fuel to some burners (typically the lower burners) while reducing fuel to other burners (typically the upper burners) to create staged combustion conditions inside a boiler.

British thermal unit (Btu): The amount of energy required to raise the temperature of a pound of water 1°F from 39.2°F.

Burners out of service (BOOS): Burners out of service is a nitrogen oxide control technique in which certain burners are removed from service by stopping fuel flow but maintaining air flow to create staged combustion conditions inside a boiler.

Burner tuning (BT): Burner tuning is an operational modification that results in reduced emissions by controlling the amount of excess oxygen available for combustion.

Carbon monoxide (CO): An odorless gas produced when fuel is burned. CO is one of the six criteria pollutants for which the U.S. Environmental Protection Agency (EPA) has established National Ambient Air Quality Standards. When CO concentrations are elevated, the ability of blood to bring oxygen to body cells and tissues is reduced.

Clean Air Act (CAA): A 1970 federal law for regulating air quality. The CAA was further expanded by amendments in 1977 and 1990. The 1990 Clean Air Act Amendments authorize the EPA to establish standards for a number of atmospheric pollutants.

Code of Federal Regulations (CFR): A series of volumes in which federal regulations are codified (e.g., Title 40, Protection of the Environment).

Criteria pollutants: The 1990 amendments to the CAA required EPA to set National Ambient Air Quality Standards for certain pollutants known to be hazardous to human health. EPA has identified and set standards to protect human health and welfare for six criteria pollutants: ozone, carbon monoxide, total suspended particulates, sulfur dioxide, lead, and nitrogen oxide.

Cubic feet per minute (cfm): A measure of the volume of a substance, such as air, that flows within a fixed period of time. With regard to a fan, cfm is a measure of the amount of gas, in cubic feet, that passes through the fan in a minute.

Electrostatic precipitator (ESP): A postcombustion emission control device used to remove particulate matter suspended in flue gas. Separation within an ESP is accomplished by electrically charging the particles. As the particles take on a negative charge, they migrate toward positively charged collector plates, thereby cleaning the flue gas.

Emission factors: The relationship between the quantity of emissions produced and the amount of raw material processed. For example, an emission factor for a coal-fired boiler is the number of pounds of particulate matter produced per ton of coal burned.

Emission inventory: A listing, by source, of the amount of air pollutants discharged into the atmosphere from an individual source.

Federal Register (FR): A daily publication of the federal government that contains, among other things, proposed and final rules issued by the EPA.

Flue gas desulfurization (FGD): A postcombustion emission control technique for removing sulfur dioxide from flue gas. Wet scrubbers, dry scrubbers, and sorbent injection represent different FGD techniques.

Flue gas recirculation (FGR): The process of injecting flue gas into a boiler along with fresh combustion air to modify conditions within the combustion zone. The result of FGR is control of nitrogen oxide formation by lowering the peak flame temperature and reducing the oxygen concentration.

Fuel-induced recirculation (FIR): A nitrogen oxide reduction technique applicable to boilers that burn gaseous fuel. FIR is similar to FGR except that a portion of the flue gas is mixed with the fuel instead of combustion air. The effect of this mixture on the combustion process is to reduce the peak flame temperature. (Caution: Fuel-induced recirculation should not be confused with forced-internal recirculation which is also represented by the acronym FIR.)

Forced-internal recirculation (FIR): An FIR burner uses a combination of premixing, staging, and interstage heat removal to control nitrogen oxide and carbon monoxide formation during combustion of natural gas. (Caution: Forced-internal recirculation should not be confused with fuel-induced recirculation which is also represented by the acronym FIR.)

Hazardous air pollutants (HAPs): Air pollutants that are not covered by ambient air quality standards but which, as defined in the CAA, may reasonably be expected to cause or contribute to irreversible illness or death. There are 188 chemical compounds considered by EPA to be HAPs.

Lead (Pb): A heavy metal that is one of the six criteria pollutants for which EPA has established National Ambient Air Quality Standards. Lead emissions result from the combustion of leaded gasoline (being phased out), use of certain paints (houses, cars), operation of smelters (metal refineries), and manufacture of lead-acid storage batteries. Combustion boilers are not a major source of lead emissions.

Lowest Achievable Emission Rate (LAER): The rate of emissions that reflects (1) the most stringent emission limitation contained in the implementation plan of any state for such source unless the owner or operator of the proposed source demonstrates that such limitations are not achievable or (2) the most stringent emission limitation achieved in practice by other sources within the same category. Application of this term does not permit a proposed new or modified source to emit pollutants in excess of existing New Source Performance Standards.

Low excess air (LEA): A boiler operating condition in which the lowest possible excess air level is provided while maintaining good combustion. Operating with LEA creates conditions within the combustion zone that lower nitrogen oxide production.

Low-NO_x burner (LNB): A specially designed piece of combustion equipment that reduces nitrogen oxide formation through careful control of the fuel-air mixture during combustion. By proper staging of fuel and air, nitrogen oxide formation is controlled due to a lower maximum flame temperature and a reduced oxygen concentration.

MBtu/h: A unit of measure for heat input (million British thermal units per hour).

Major modification: A modification with respect to Prevention of Significant Deterioration and New Source Review under the CAA.

Major stationary sources: Term used to determine the applicability of Prevention of Significant Deterioration and New Source Review regulations. In a nonattainment area, any stationary source that has a potential to emit more than 100 tons/year is considered a major stationary source. In attainment areas, the cutoff level may be either 100 or 250 tons/year, depending upon the type of source.

Maximum Achievable Control Technology (MACT): Emission limitations based on the best demonstrated control technology or practices in similar sources to be applied to major sources emitting one or more of the listed HAPs.

National Ambient Air Quality Standards (NAAQS): Uniform air quality standards established by the EPA that apply to outside air throughout the country. (See criteria pollutants.)

National Emissions Standards for Hazardous Air Pollutants (NESHAPs): Emission standards set by the EPA for air pollutants, not covered by NAAQS, that may cause an increase in deaths or in a serious illness. Primary standards are designed to protect human health; secondary standards are designed to protect public welfare.

Natural gas reburning (NGR): A combustion modification technique for reducing NO_x emissions. NGR involves the staging of fuel rather than combustion air. In this technique, a portion of the fuel is injected downstream of the main combustion zone. The result is reduced NO_x formation through lower peak flame temperatures and reduced oxygen concentrations.

New source: Any stationary source that is built or modified after publication of final or proposed regulations that prescribe a standard of performance that is intended to apply to that type of emission source.

New Source Performance Standards (NSPS): Uniform national air emissions requirements that limit the amount of pollution allowed from specific new sources or from existing sources that have been modified.

Nonattainment area: A geographic area that does not meet one or more of the NAAQS for the criteria pollutants designated in the CAA.

Nitrogen oxides (NO_x): The cumulative emissions of nitric oxide (NO), nitrogen dioxide (NO₂), and other trace compounds of nitrogen produced when fuel is burned. Lung damage and acid rain can result when NO_x concentrations are elevated. NO_x is one of the six criteria pollutants for which EPA has established NAAQS.

Oxygen trim (OT): A boiler operational modification that limits the amount of excess oxygen available for combustion.

Overfire air (OFA): Combustion air that is injected into a boiler above the normal combustion zone. OFA is generally used in conjunction with operating the burners at a lower than normal air-to-fuel ratio to reduce NO_x formation. When this technique is used, OFA is supplied above the main combustion zone to achieve complete combustion. OFA is often a design feature incorporated into a LNB design.

Ozone (O₃): Ground-level ozone is formed when vehicle exhaust and combustion emissions mix with certain other chemicals in the presence of strong sunlight. When the ozone concentration is elevated, it can make breathing difficult, especially for people with asthma and other respiratory diseases. Ozone is one of the six criteria pollutants for which EPA has established NAAQS.

Particulate matter (PM): Particles consisting of fine liquid or solid particles such as dust, smoke, mist, fumes, or smog found in air or emissions from combustion. Nose and throat irritation, lung damage, bronchitis, and early death are health effects associated with PM emissions. PM is one of the six criteria pollutants for which EPA has established NAAQS.

PM₁₀: Particulate matter such as soot, dust, smoke, fumes, and mist with an aerodynamic diameter less than or equal to a nominal 10 μm.

PM_{2.5}: Particulate matter such as soot, dust, smoke, fumes, and mist with an aerodynamic diameter less than or equal to a nominal 2.5 μm.

Parts per million (ppm): A way of expressing concentrations of pollutants in air, water, soil, human tissue, food, or other products.

Potential to emit: The rate of emission of an air contaminant of a process or process equipment while being operating at its maximum rated capacity. Certain physical or operational limits that are legally enforceable can decrease the potential to emit.

Prevention of Significant Deterioration: A regulatory program used to evaluate permits for new or modified sources in attainment areas. The intent is to prevent an attainment area from becoming a nonattainment area.

psig: A unit of pressure measurement (pounds per square inch gauge).

Reasonably Available Control Measures (RACM): A broadly defined term referring to technologies and other measures that can be used to control pollution. It includes Reasonably Available

Control Technology and other measures. In the case of PM₁₀, RACM refers to approaches for controlling small or dispersed source categories, such as road dust, wood stoves, and open burning.

Reasonably Available Control Technology (RACT): Technology for producing the lowest emissions limit that a particular source is capable of meeting by the application of control technology that is both reasonably available, as well as technologically and economically feasible. RACT applies to existing sources in nonattainment areas.

Reducing air preheat (RAP): An NO_x reduction technique in which the temperature of preheated combustion air is lowered. Reducing the air preheat temperature can lower the peak flame temperature and result in reduced thermal NO_x formation.

Selective catalytic reduction (SCR): A postcombustion emission control technique for reducing NO_x emissions. SCR uses a catalyst and a reductant (ammonia gas) to dissociate NO_x to nitrogen gas and water vapor.

Selective noncatalytic reduction (SNCR): A postcombustion emission control technique for reducing NO_x emissions. SNCR uses a reducing agent of either ammonia or urea to dissociate NO_x to nitrogen gas and water vapor.

Source: A term that applies to each point at which emissions are released or an entire facility where a pollutant is emitted.

Sulfur dioxide (SO₂): A pollutant that is often emitted during the combustion of sulfur-bearing fuels. In elevated concentrations, it can cause breathing problems, including permanent damage to lungs. SO₂ is one of the six criteria pollutants for which EPA has established NAAQS.

Staged combustion: An NO_x control technique based on the fact that combustion at either very low or very high excess air levels results in reduced NO_x formation. By mixing air and fuel at two or more locations inside a boiler, it is possible to create zones with high and low excess air levels.

Staged combustion air (SCA): Air that is injected into a boiler at different points or stages in the combustion process. SCA is used to reduce the peak flame temperature or lower the oxygen concentration and thereby control NO_x formation. Techniques based on this concept include BOOS, BF, OFA, and LNBs.

State implementation plans (SIP): EPA approved state plans for establishment, regulation, and enforcement of air pollution standards.

Stationary source: A fixed, nonmoving producer of pollution, mainly power plants, manufacturing facilities, refineries, and other facilities that emit air pollutants.

Steam injection (SI): A combustion control technique used to reduce the peak flame temperature and thereby control NO_x formation. In this technique, steam is injected into the combustion zone.

Tons per year (tons/year): A unit of measure used to characterize an emission rate. One ton equals 2000 pounds.

Turndown: The ratio of maximum fuel flow to minimum fuel flow.

Ultra low-NO_x burner (ULNB): An LNB that is capable of reducing NO_x emissions to low levels, usually below 30-ppm volumetric, corrected to 3% oxygen.

Volatile organic compound (VOC): Any organic compound that participates in atmospheric photochemical reactions except those designated by the EPA Administrator as having negligible photochemical reactivity.

Water injection (WI): A combustion control technique used to reduce the peak flame temperature and thereby control NO_x formation. In this technique, water is injected into the combustion zone.

Appendix A

**NEW SOURCE PERFORMANCE STANDARDS
UNDER TITLE IV OF THE CLEAN AIR ACT**

Table A.1. Summary of new source performance standards (NSPS) for electric utility steam-generating units^a

Pollutant	Fuel or combustion process	NSPS ^b	
		Maximum emission rate	Required reduction in potential combustion concentration ^c
Particulate matter (PM) 40 CFR 60.42a (NSPS for PM apply at all times except during periods of startup, shutdown, or malfunction)	Solid, liquid, or gaseous fuels	0.03-lb/MBtu heat input	99% of the potential combustion concentration for solid fuels, 70% for liquid fuels
	Sulfur dioxide (SO ₂) 40 CFR 60.43a [NSPS for SO ₂ apply at all times except during periods of startup, shutdown, or when both emergency conditions exist and procedures described in 40 CFR 60.46a(d) are implemented]	Solid or solid-derived fuel	1.20-lb/MBtu heat input
A-3	Liquid or gaseous fuels except liquid or gaseous fuels derived from solid fuels	0.80-lb/MBtu heat input	90% of the potential combustion concentration, or 0% when emissions are less than 0.20-lb/MBtu heat input
	Solid solvent refined coal (SRC-I)	1.20-lb/MBtu heat input	85% of the potential combustion concentration except facilities operated under an SO ₂ commercial demonstration permit [see 40 CFR 60.45a(b)]
	100% anthracite coal	1.20-lb/MBtu heat input	No emission reduction requirements
	Facilities classified as resource recovery facilities	1.20-lb/MBtu heat input	No emission reduction requirements
	Solid fuel or solid-derived fuel combusted in a facility located in a non-continental area	1.20-lb/MBtu heat input	No emission reduction requirements
	Liquid or gaseous fuels (except solid-derived fuels) combusted in a facility that is located in a noncontinental area	0.80-lb/MBtu heat input	No emission reduction requirements
	Facilities that combust different fuels simultaneously	The rate is determined by proration using formulae that depend on whether the emissions are greater or less than 0.60-lb/MBtu heat input [see 40 CFR 60.43a(h)]	The applicable standard is determined by proration using formulae that depend on whether the emissions are greater or less than 0.60 lb/MBtu heat input [See 40 CFR 60.43a(h)]

Table A.1. (continued)

Pollutant	Type of fuel or combustion process	NSPS ^b	
		Maximum emission rate	Required reduction in potential combustion concentration ^c
Nitrogen oxides ^d (expressed as NO ₂) 40 CFR 60.44a (NSPS for NO _x apply at all times except during periods of startup, shutdown, or malfunction)	Solid solvent refined coal (SCR-I) combusted in a facility that has a commercial demonstration permit	1.20-lb/MBtu heat input	80% of the potential combustion concentration [see 40 CFR 60.45a(b)]
	Fluidized-bed combustion (FBC) electric utility steam generator units (atmospheric or pressurized) that have a commercial demonstration permit	1.20-lb/MBtu heat input	85% of the potential combustion concentration [see 40 CFR 60.45a(c)]
	Coal-derived gaseous fuels	0.50-lb/MBtu heat input	25% of the potential combustion concentration
	Gaseous fuels except coal-derived gaseous fuels	0.20-lb/MBtu heat input	25% of the potential combustion concentration
	Coal-derived liquid fuels	0.50-lb/MBtu heat input	30% of the potential combustion concentration
	Shale oil	0.50-lb/MBtu heat input	30% of the potential combustion concentration
	Liquid fuels except coal-derived fuels and shale oil	0.30-lb/MBtu heat input	30% of the potential combustion concentration
	Coal-derived solid fuel	0.50-lb/MBtu heat input	65% of the potential combustion concentration
	Any solid fuel containing more than 25%, by weight, coal refuse	Exempt from NO _x standards and NO _x monitoring requirements	Exempt from NO _x standards and NO _x monitoring requirements
	Any solid fuel containing more than 25%, by weight, lignite if the lignite is mined in ND, SD, or MT and is combusted in a slag tap furnace	0.80-lb/MBtu heat input	65% of the potential combustion concentration

Table A.1. (continued)

Pollutant	Type of fuel or combustion process	NSPS ^b	
		Maximum emission rate	Required reduction in potential combustion concentration ^c
	Any solid fuel containing more than 25%, by weight, lignite not subject to the 0.80-lb/MBtu heat input limit	0.50-lb/MBtu heat input	65% of the potential combustion concentration
	Subbituminous coal	0.50-lb/MBtu heat input	65% of the potential combustion concentration
	Bituminous coal	0.60-lb/MBtu heat input	65% of the potential combustion concentration
	Anthracite coal	0.60-lb/MBtu heat input	65% of the potential combustion concentration
	All other solid fuels	0.60-lb/MBtu heat input	65% of the potential combustion concentration
	Coal-derived liquid fuel combusted in a facility that has a commercial demonstration permit	0.70-lb/MBtu heat input	Exempt from emission reduction requirements
	Any fossil fuel combusted in an electric steam generating unit constructed after July 9, 1997 ^e	1.6-lb/MWh gross energy output	No emission reduction requirements

^aStandards are provided for reference only, consult 40 CFR 60, Subpart Da for details.¹

^bBoth the maximum emission rate and the required reduction of potential combustion concentration must be met by affected facilities with electric steam generating units that are capable of combusting more than 250-MBtu/h heat input of fossil fuels (either alone or in combination with any other fuel) and for which construction or modification began after September 18, 1978.

^cPotential combustion concentration means the theoretical emissions in pounds per million British thermal units heat input that would result from combustion of fuel in an uncleaned state without emission control systems.

- For PM the potential combustion concentration is 7.0-lb/MBtu heat input for solid fuels and 0.17-lb/MBtu heat input for liquid fuels (see 40 CFR 60.41a).
- For SO₂ the percent of potential emissions to the atmosphere is computed using the formula provided in 40 CFR 60.48a(c).
- For NO₂ the potential combustion concentration is 0.67-lb/MBtu heat input for gaseous fuels, 0.72-lb/MBtu heat input for liquid fuels, and 2.30-lb/MBtu heat input for solid fuels (see 40 CFR 60.41a).

^dThe emissions rate for a facility that combusts two or more fuels simultaneously is determined by proration using a formula that depends on the types of fuels used and their relative proportions [see 40 CFR 60.44a(c)].

^eFor all new sources in which construction began after July 9, 1997, NO_x expressed as NO must not exceed 1.6-lb/MWh gross energy output. For existing sources in which reconstruction began after July 9, 1997, NO_x expressed as NO must not exceed more than 0.15-lb/MBtu heat input [see 40 CFR 60.45a(d)].

Table A.2. Summary of NSPS for industrial-commercial-institutional (ICI) steam-generating units^a

Pollutant	Fuel or combustion process	NSPS ^b	
		Maximum emission rate	Required reduction in potential combustion concentration ^c
PM 40 CFR 60.43b (NSPS for PM apply at all times except during periods of startup, shutdown, or malfunction)	Coal combusted alone	0.05-lb/MBtu heat	No emission reduction requirements
	Mixtures of coal with other fuels combusted in a facility that has an annual capacity factor ^d for the other fuels of 10% or less	0.05-lb/MBtu heat input	No emission reduction requirements
	Mixtures of coal with other fuels combusted in a facility that has an annual capacity factor ^d for the other fuels greater than 10%	0.10-lb/MBtu heat input	No emission reduction requirements
	Coal or coal and other fuels provided the facility has an annual capacity factor of 30% or less, has a maximum heat input capacity of 250,000 MBtu/h or less, and construction commenced after June 19, 1984 and before November 25, 1986	0.20-lb/MBtu heat input	No emission reduction requirements
	Oil or mixtures of oil with other fuels and the unit uses a conventional or emerging technology to reduce SO ₂ emissions	0.10-lb/MBtu heat input	No emission reduction requirements
	Wood or wood with other fuels except coal provided the facility has an annual capacity factor greater than 30% for wood	0.10-lb/MBtu heat input	No emission reduction requirements
	Wood or wood with other fuels except coal provided the facility has an annual capacity factor less than 30% for wood and has a maximum heat input capacity of 250 MBtu/h or less	0.20-lb/MBtu heat input	No emission reduction requirements
	Municipal-type solid waste	0.10-lb/MBtu heat input	No emission reduction requirements

Table A.2. (continued)

Pollutant	Fuel or combustion process	NSPS ^b	
		Maximum emission rate	Required reduction in potential combustion concentration ^c
SO ₂ 40 CFR 60.42b NSPS for SO ₂ apply at all times, including periods of startup, shutdown, and malfunction [see 40 CFR 60.42b(g)]	Municipal-type solid waste or mixtures of municipal-type solid waste and other fuels provided the facility has an annual capacity factor for the other fuels of 10% or less	0.10-lb/MBtu heat input	No emission reduction requirements
	Municipal-type solid waste or mixtures of municipal-type solid waste and other fuels provided the facility has an annual capacity factor for municipal-type solid waste and other fuels of 30% or less, has a maximum heat input capacity of 250 MBtu/h or less, and construction commenced after June 19, 1984 and before November 25, 1986	0.20-lb/MBtu heat input	No emission reduction requirements
	Coal or oil combusted alone	The rate is determined by proration using a formula that depends on the fuels used and their relative proportions [see 40 CFR 60.42b(a)]	90% of the potential combustion concentration
	Coal refuse combusted in an FBC steam-generating unit	1.20-lb/MBtu heat input	80% of the potential combustion concentration
	Coal refuse combusted in a FBC steam-generating unit with coal or oil	The rate is determined by proration using a formula that depends on the fuels used and their relative proportions [see 40 CFR 60.42b(b)]	90% of the potential combustion concentration [see 40 CFR 60.42b(b)]
	Coal or oil, either alone or in combination with any other fuel combusted in a unit that uses an emerging technology to control SO ₂ emissions ^e	The rate is determined by proration using a formula that depends on the fuels used and their relative proportions [see 40 CFR 60.42b(c)]	50% of the potential combustion concentration

Table A.2. (continued)

Pollutant	Fuel or combustion process	NSPS ^b	
		Maximum emission rate	Required reduction in potential combustion concentration ^c
Nitrogen oxides (expressed as NO ₂) 40 CFR 60.44b NSPS for NO ₂ apply at all times including periods of startup, shutdown, and malfunction [see 40 CFR 60.44b(h)]	Coal provided the facility has an annual capacity factor for coal of 30% or less, is located in a noncontinental area, or combustion occurs in a duct burner operated in accordance with requirement in 40 CFR 60.42b(d)	1.20-lb/MBtu heat input	Exempt from emission reduction requirements
	Oil other than low-sulfur oil provided the facility has an annual capacity factor for oil of 30% or less, is located in a noncontinental area, or combustion occurs in a duct burner operated in accordance with requirement in 40 CFR 60.42b(d)	0.50-lb/MBtu heat input	Exempt from emission reduction requirements
	Coal combusted in a steam generating unit with a mass-feed stoker	0.50-lb/MBtu heat input	No emission reduction requirements
	Coal combusted in a steam generating unit with spreader stoker and FBC	0.60-lb/MBtu heat input	No emission reduction requirements
	PC	0.70-lb/MBtu heat input	No emission reduction requirements
	Lignite that is not mined in ND, SD, or MT and combusted in a slag tap furnace	0.60-lb/MBtu heat input	No emission reduction requirements
	Lignite mined in ND, SD, or MT and combusted in a slag tap furnace	0.80-lb/MBtu heat input	No emission reduction requirements
	Coal-derived synthetic fuels	0.50-lb/MBtu heat input	No emission reduction requirements
Low-heat release rate natural gas and distillate oil that is not combusted in a duct burner used in a combined cycle system	0.10-lb/MBtu heat input	No emission reduction requirements	

Table A.2. (continued)

Pollutant	Fuel or combustion process	NSPS ^b	
		Maximum emission rate	Required reduction in potential combustion concentration ^c
	High-heat release rate natural gas and distillate oil that is not combusted in a duct burner used in a combined cycle system	0.20-lb/MBtu heat input	No emission reduction requirements
	Low-heat release rate residual oil	0.30-lb/MBtu heat input	No emission reduction requirements
	High-heat release rate residual oil	0.40-lb/MBtu heat input	No emission reduction requirements
	Natural gas and distillate oil combusted in a duct burner used in a combined cycle system	0.20-lb/MBtu heat input	No emission reduction requirements
	Residual oil combusted in a duct burner used in a combined cycle system	0.40-lb/MBtu heat input	No emission reduction requirements
	Mixtures of coal, oil, or natural gas combusted simultaneously	The rate is determined by proration using a formula that depends on the fuels used and their relative proportions [see 40 CFR 60.44b(b)]	No emission reduction requirements
	Coal or oil, or a mixture of these fuels with natural gas, combusted simultaneously with wood, municipal-type solid waste, or any other fuel	Determine maximum emission rate using requirements provided in 40 CFR 60.44b(c)	No emission reduction requirements
	Natural gas combusted simultaneously with wood, municipal-type solid waste, or other solid fuel, except coal	0.30-lb/MBtu heat input unless the facility has an annual capacity factor for natural gas of 10% or less	No emission reduction requirements
	Coal, oil, or natural gas combusted simultaneously with by-product/waste	The rate is determined by proration using a formula that depends on the fuels used and their relative proportions unless the facility has an annual capacity factor for coal, oil, and natural gas of 10% or less [see 40 CFR 60.44b(e)]	No emission reduction requirements
	By-product/waste combusted with either natural gas or oil	Determine maximum emission rate using requirements provided in 40 CFR 60.44b(f)	No emission reduction requirements
	Hazardous waste combusted with either natural gas or oil	Determine maximum emission rate using requirements provided in 40 CFR 60.44b(g)	No emission reduction requirements

Table A.2. (continued)

Pollutant	Fuel or combustion process	NSPS ^b	
		Maximum emission rate	Required reduction in potential combustion concentration ^c
	Natural gas, distillate oil, or residual oil with a nitrogen content of 0.30 wt % or less combusted alone or in combination in a facility with a heat input capacity of 250 MBtu/h or less and a combined annual capacity factor of 10% or less for natural gas, distillate oil, or residual oil with a nitrogen content of 0.30 wt % or less	Exempt from NO _x emission limits [see 40 CFR 60.44b(k)]	No emission reduction requirements
	Coal, oil, or natural gas, or a mixture of these fuels, or with any other fuels combusted in an industrial-commercial-institutional steam generating unit constructed after July 9, 1997 ^f	0.20-lb/MBtu heat input	No emission reduction requirements

^aStandards are provided for reference only, consult 40 CFR 60, Subpart Db for details.²

^bBoth the maximum emission rate and the required reduction of potential combustion concentration must be met by affected facilities with ICI steam-generating units that are capable of combusting more than 100-MBtu/h heat input and for which construction, modification, or reconstruction began after June 19, 1984. These standards must also be met by coal-fired and oil-fired units with heat input capacities between 100 and 250 MBtu/h and certain coal-fired and oil-fired units with heat input capacities greater 250 MBtu/h for which construction, modification, or reconstruction began after June 19, 1984, but on or before June 19, 1986. (See 40 CFR 60.40b for specific requirements.)

^cPotential combustion concentration means the theoretical emissions in pounds per million British thermal units heat input that would result from combustion of fuel in an uncleaned state without emission control systems. For SO₂ the determination of potential combustion concentration is based on requirements provided in 40 CFR 60.45b and 40 CFR 60, Appendix A, Method 19.

^dAnnual capacity factor means the ratio between the actual heat input from the fuels during a calendar year and the potential heat input if the unit had operated for 8760 h during a calendar year at the maximum steady state design heat input capacity [see 40 CFR 60.43b(e)].

^eEmerging technology means any SO₂ control system besides wet flue gas desulfurization (FGD) technology, dry FGD technology, atmospheric FBC technology, and oil hydrodesulfurization technology for which the owner or operator has received approval for EPA as an emerging technology (see 40 CFR 60.41b).

^fFor all new sources in which construction began after July 9, 1997, that combust coal, oil, or natural gas, or mixtures of these fuels, or with other fuels, NO_x expressed as NO must not exceed: (1) 0.20-lb/MBtu heat input unless the facility has an annual capacity factor for coal, oil, and natural gas of 10% or less or (2) the limit determined by the formula given in 40 CFR 60.44b(1)(2) provided the facility has a low-heat release rate and combusts natural gas or distillate oil in excess of 30% of the heat input from the combustion of all the fuels.

Table A.3. Summary of NSPS for small industrial ICI-generating units^a

Pollutant	Type of fuel or combustion process	NSPS ^b	
		Maximum emission rate	Required reduction in potential combustion concentration ^c
PM 40 CFR 60.43c NSPS for PM apply at all times except during periods of startup, shutdown, or malfunction	Coal or coal with other fuels combusted in a facility with a heat input capacity of 30 MBtu/h or greater and an annual capacity factor ^d for the other fuels of 10% or less	0.05-lb/MBtu heat	No emission reduction requirements
	Coal or coal with other fuels combusted in a facility with a heat input capacity of 30 MBtu/h or greater and an annual capacity factor ^d for the other fuels greater than 10%	0.10-lb/MBtu heat input	No emission reduction requirements
	Wood or mixtures of wood with other fuels, except coal, combusted in a facility with a heat input capacity of 30 MBtu/h or greater and an annual capacity factor ^d for wood greater than 30%	0.10-lb/MBtu heat input	No emission reduction requirements
	Wood or mixtures of wood with other fuels, except coal, combusted in a facility with a heat input capacity of 30 MBtu/h or greater and an annual capacity factor ^d for wood of 30% or less	0.30-lb/MBtu heat input	No emission reduction requirements
SO ₂ 40 CFR 60.42c NSPS for SO ₂ apply at all times, including periods of startup, shutdown, and malfunction [see 40 CFR 60.42c(i)]	Coal combusted alone	1.20-lb/MBtu heat input	90% of the potential combustion concentration

Table A.3. (continued)

Pollutant	Type of fuel or combustion process	NSPS ^b	
		Maximum emission rate	Required reduction in potential combustion concentration ^c
	Coal combusted with other fuels	The rate is determined by proration using a formula that depends on the types of fuels used and their relative proportions [see 40 CFR 60.42c(e)(2)]	90% of the potential combustion concentration
	Coal refuse combusted in an FBC steam generating	1.20-lb/MBtu heat input	80% of the potential combustion concentration
	Coal combusted with coal refuse in an FBC steam-generating unit	The rate is determined by proration using a formula that depends on the fuels used and their relative proportions [see 40 CFR 60.42c(e)(2)]	90% of the potential combustion concentration
	Oil or any other fuel, except coal, combusted with coal refuse in an FBC steam-generating unit	The rate is determined by proration using a formula that depends on the fuels used and their relative proportions [see 40 CFR 60.42c(e)(2)]	90% of the potential combustion concentration
	Coal combusted in a facility that uses emerging technology for the control of SO ₂ emissions ^e	0.60-lb/MBtu heat input	50% of the potential combustion concentration
	Coal combusted with other fuels in a facility that uses emerging technology for the control of SO ₂ emissions ^e	The rate is determined by proration using a formula that depends on the fuels used and their relative proportions [see 40 CFR 60.42c(e)(2)]	50% of the potential combustion concentration
	Coal combusted alone or in combination with other fuel in a facility with a heat input capacity of 75 MBtu/h or less	The rate is determined by proration using a formula that depends on the fuels used and their relative proportions [see 40 CFR 60.42c(e)(2)]	No emission reduction requirements
	Coal combusted alone or in combination with other fuel in a facility with an annual capacity factor ^d for coal of 55% or less	The rate is determined by proration using a formula that depends on the fuels used and their relative proportions [see 40 CFR 60.42c(e)(2)]	No emission reduction requirements
	Coal combusted alone or in combination with other fuel in a facility located in a noncontinental area	The rate is determined by proration using a formula that depends on the fuels used and their relative proportions [see 40 CFR 60.42c(e)(2)]	No emission reduction requirements

Table A.3. (continued)

Pollutant	Type of fuel or combustion process	NSPS ^b	
		Maximum emission rate	Required reduction in potential combustion concentration ^c
	Coal combusted in a duct burner as part of a combined cycle system where 30% or less of the heat entering the steam generating unit is from combustion of coal in the duct burner	The rate is determined by proration using a formula that depends on fuels used and their relative proportions [see 40 CFR 60.42c(e)(2)]	No emission reduction requirements
	Oil combusted alone	0.50-lb/MBtu heat input	No emission reduction requirements
	Oil with a sulfur content no greater than 0.5 wt % combusted alone	No maximum emission rate [see 40 CFR 60.42c(d)]	No emission reduction requirements
	Coal, oil, or coal and oil combusted with any other fuel in a facility with a heat input capacity of 75-MBtu/h or greater and an annual capacity factor ^d for coal greater than 55%	The rate is determined by proration using a formula that depends on the fuels used and their relative proportions [see 40 CFR 60.42c(e)(2)]	90% of the potential combustion concentration
	Coal, oil, or coal and oil combusted with any other fuel in a facility that uses emerging technology to control SO ₂ emissions, ^e has a heat input capacity of 75 MBtu/h or greater, and has an annual capacity factor ^d for coal greater than 55%	The rate is determined by proration using a formula that depends on the types of fuels used and their relative proportions [see 40 CFR 60.42c(e)(2)]	50% of the potential combustion concentration
Nitrogen oxides	All fuels	No emission limits are included in 40 CFR 60.40c	No emission reduction requirements are included in 40 CFR 60.40c

^aStandards are provided for reference only, consult 40 CFR 60, Subpart Dc for details.³

^bBoth the maximum emissions rate and the required reduction of potential combustion concentration must be met by affected facilities with small ICI steam-generating units that are capable of combusting between 10- and 100-MBtu/h heat input and for which construction, modification, or reconstruction began after June 9, 1989.

^cPotential combustion concentration means the theoretical emissions in lb/MBtu heat input that would result from combustion of fuel in an uncleaned state without emission control systems. For SO₂ the determination of potential combustion concentration is based on requirements provided in 40 CFR 60.44c.

^dAnnual capacity factor means the ratio between the actual heat input to a steam generating unit from an individual fuel or combination of fuels during a period of 12 consecutive calendar months and the potential heat input to the steam generating unit from all fuels (see 40 CFR 60.41c).

^eEmerging technology means any SO₂ control system that meets the definition provided in 40 CFR 60.41c.

Table A.4. Summary of NSPS for large municipal waste combustion units^a

Pollutant	NSPS^b maximum emission rate
PM 40 CFR 60.52b(a)(1)	24 mg/m ³ dry, corrected to 7% oxygen
Cadmium 40 CFR 60.52b(a)(3)	0.020 mg/m ³ dry, corrected to 7% oxygen
Lead 40 CFR 60.52b(a)(4)	0.20 mg/m ³ dry, corrected to 7% oxygen
Mercury 40 CFR 60.52b(a)(5)	0.080 mg ³ /dry or 15% of the potential mercury emission concentration (85% reduction by weight), corrected to 7% oxygen, whichever is less stringent
Sulfur dioxide 40 CFR 60.52b(b)(1)	30 ppm by volume or 20% of the potential SO ₂ emission concentration (80% reduction by weight or volume), corrected to 7% oxygen (dry basis), whichever is less stringent
Hydrogen chloride 40 CFR 60.52b(b)(2)	25 ppm by volume or 5% of the potential hydrogen chloride emission concentration (95% reduction by weight or volume), corrected to 7% oxygen (dry basis), whichever is less stringent
Dioxin/furan 40 CFR 60.52b(c)	30 ng/m ³ dry (total mass), corrected to 7% oxygen for units constructed on or before November 20, 1997. 13 ng/m ³ dry, corrected to 7% oxygen for units constructed after November 20, 1997.
NO _x 40 CFR 60.52b(d)	150 ppm by volume, corrected to 7% oxygen (dry basis)

^aA large municipal waste combustor is any waste combustor unit with a combustion capacity of 250 tons/d of MSW for which construction is commenced after September 20, 1994, or for which modification or reconstruction is commenced after June 19, 1996.

^bStandards are provided for reference only, consult 40 CFR 60, Subpart Eb for details.⁴

REFERENCES

1. "Standards of Performance for Electric Utility Steam Generating Units for Which Construction is Commenced After September 18, 1978," 40 CFR 60, Da, U.S. Environmental Protection Agency.
2. "Standards of Performance for Industrial-Commercial-Institutional Steam Generating Units," 40 CFR 60, Db, U.S. Environmental Protection Agency.
3. "Standards of Performance for Small Industrial-Commercial-Institutional Steam Generating Units," 40 CFR 60, Dc, U.S. Environmental Protection Agency.
4. "Standards of Performance for Large Municipal Waste Combustors for Which Construction is Commenced After September 20, 1994, or for Which Modification or Reconstruction is Commenced After June 19, 1996," 40 CFR 60, Eb, U.S. Environmental Protection Agency.

INTERNAL DISTRIBUTION

1. D. K. Felde
2. E. C. Fox
- 3–5. C. B. Oland
6. M. Olszewski
7. C. C. Southmayd
8. A. J. Szady
- 9–11. A. L. Wright
12. G. L. Yoder
13. ORNL Laboratory Records (OSTI)

EXTERNAL DISTRIBUTION

- 14–23. R. D. Bessette, President, Council of Industrial Boiler Owners, 6035 Burke Centre Parkway, No. 360, Burke, VA 22015
- 24–28. J. Eddinger, Emission Standards Division, U.S. Environmental Protection Agency, Research Triangle Park, NC 27711
- 29–31. R. V. Gemmer, U.S. Department of Energy, 1000 Independence Avenue SW, Washington, DC 20585-0121
32. G. Harrell, Ph.D., P.E., Senior Research Associate, The University of Tennessee–Knoxville, Environmental and Resources Center, 311 Conference Center Building, Knoxville, TN 37996-4134
- 33–35. F. L. Hart, U.S. Department of Energy, 1000 Independence Avenue SW, Washington, DC 20585-0121
36. C. B. Hooper, Steam Solutions, Inc., 2220 Banstead Road, Midlothian, VA 23113
37. J. S. Moore, TA Engineering, Inc., Catonsville Professional Center, 405 Frederick Road, Suite 252, Baltimore, MD 21228
- 38–40. R. N. Mosher, President, R. N. Mosher & Associates, 3997 Gumwod Court, Chantilly, VA 20151-2601
41. F. Porter, Emission Standards Division, U.S. Environmental Protection Agency, Research Triangle Park, NC 27711
- 42–51. W. R. Rawson, President, American Boiler Manufacturers Association, 4001 N. 9th St., Suite 226, Arlington, VA 22203-1900