

Practical Sequence Stratigraphy

MFS

By Dr. Ashton Embry



Practical Sequence Stratigraphy was originally published as a fifteen-part series in the Canadian Society of Petroleum Geologists' monthly magazine, *The Reservoir*, between May 2008 and September 2009.

The CSPG thanks Dr. Ashton Embry for his work in making this series possible.

Suggested reference for this compilation is: Embry, A.F. 2009. Practical Sequence Stratigraphy. Canadian Society of Petroleum Geologists, Online at www.cspg.org, 81 p.

Practical Sequence Stratigraphy

Contents

1) Introduction	1
2) Historical Development of the discipline:The First 200 Years (1788-1988)	3
3) Historical Development of the discipline:The Last 20 Years (1998-2008)	7
4) The Material-based Surfaces of Sequence Stratigraphy, Part 1: Subaerial Unconformity and Regressive Surface of Marine Erosion	11
5) The Material-based Surfaces of Sequence Stratigraphy, Part 2: Shoreline Ravinement and Maximum Regressive Surface	15
6) The Material-based Surfaces of Sequence Stratigraphy, Part 3: Maximum Flooding Surface and Slope Onlap Surface	21
7) The Base-Level Change Model for Material-based, Sequence Stratigraphic Surfaces	27
8) The Time-based Surfaces of Sequence Stratigraphy	33
9) The Units of Sequence Stratigraphy, Part 1: Material-based Sequences	39
10) The Units of Sequence Stratigraphy, Part 2: Time-based Depositional Sequences	45
11) The Units of Sequence Stratigraphy, Part 3: Systems Tracts	49
12) The Units of Sequence Stratigraphy, Part 4: Parasequences	55
13) Sequence Stratigraphy Hierarchy	59
14) Correlation	65
15) Tectonics vs. Eustasy and Applications to Petroleum Exploration	71

Acknowledgements

Above all, I have to acknowledge the major contributions of Hollis Hedberg, the father of modern stratigraphic practice. Over a time span of 40 years (late 1930s - late 1970s) he established the guiding principles for stratigraphic classification and nomenclature. His concepts and advice are just as relevant today as they were when they were formulated.

I would also like to thank Ben McKenzie, the editor of the CSPG Reservoir. He encouraged me to produce this series of articles on sequence stratigraphy and he carefully edited each one. He also did an excellent job of producing this compilation.

Thanks also go to Heather Tyminski, the CSPG Communications Coordinator, who looked after the layout of each article and was always available for consultation.

I have discussed sequence stratigraphic concepts with many individuals over the past 40 years and I am thankful for having the opportunity to do so. Erik Johannessen of StatoilHydro and Benoit Beauchamp of the University of Calgary have been especially helpful and they have consistently taken me to task when I lapsed into sloppy thinking. Many of the concepts in these articles are the result of our many conversations and debates.

I would like to thank my employer, the Geological Survey of Canada, which fostered and funded my research and allowed the publication of these articles. I must also thank my colleague, Dave Sargent, who expertly drafted all the diagrams and improved the design of many.

Practical Sequence Stratigraphy I

Introduction

by Ashton Embry

This is the first in a series of articles on one of my favorite subjects: sequence stratigraphy. I have called the series practical sequence stratigraphy because I'll be emphasizing the application of the discipline rather than dwelling on theoretical models. Each article will cover one main topic and I hope by the end of the series anyone who has had the fortitude to read all the articles will have a good idea what sequence stratigraphy is and how it can be used to help find petroleum.

During the last 30 years, sequence stratigraphy has been discussed in dozens of books and thousands of scientific papers. It also has become the most commonly used stratigraphic discipline for developing a correlation framework within a sedimentary basin because of the low costs associated with such an analysis as well as its applicability in many cases to a well log and seismic data base in addition to cores and outcrop. Despite such popularity, considerable confusion and various misconceptions are associated with the methods and terminology (e.g., unit definition) for sequence stratigraphy. This is unfortunate because sequence stratigraphy can be an excellent foundation for facies analysis and consequent interpretations of paleogeographic evolution and depositional history of portions of a sedimentary basin.

I became involved in developing sequence stratigraphic methodology because I found I could not apply the methods and terminology proposed by Exxon scientists almost 20 years ago. As a stratigrapher for the Geological Survey of Canada, my main focus is on the description and interpretation of the Mesozoic succession of the Canadian Arctic Archipelago. Sequence analysis is an essential part of such work and I found it frustrating that I could not apply the proposed Exxonian methods and terminology in a rigorous scientific manner. Furthermore, when I went through the literature in an attempt to see how others were applying the Exxonian methods, I found that the applications were either seriously flawed or did not really employ the Exxonian methods. This led me to develop methods and terminology which, above all, were guided by objectivity and reproducibility. I also made sure that such methods and terminology could be used in diverse geological settings, from outcrop to

subsurface, and from undisturbed basin fills to tectonically disrupted areas with only fragmentary records. Finally, I also addressed the issue of data type because it is essential that any proposed methods and terms can be used equally well with outcrop sections, mechanical well logs supported by chip samples and scattered core, seismic data, or any combination of these data types. In these efforts I was assisted by colleagues at the GSC, especially Benoit Beauchamp and Jim Dixon, who also experienced the same problems as I did when it came to the application of sequence stratigraphy to regional stratigraphic successions. I also received a great deal of help and feedback from my friend Erik Johannessen of StatoilHydro, who saw the problems stemming from Exxonian sequence stratigraphy from the perspective of a petroleum explorationist.

This series of articles will summarize the terminology and methods which I and my colleagues have found most useful in our sequence stratigraphic studies. This methodology has many features in common with the Exxon work but it also has significant differences. I hope to demonstrate that sequence stratigraphy, when properly utilized, provides a very reliable way to correlate stratigraphic cross-sections with accuracy and precision. The preparation of such cross-sections is a fundamental activity in the exploration for stratigraphically trapped oil and gas and the use of sequence stratigraphy significantly enhances the chance of success of any stratigraphic petroleum prospect. Sequence stratigraphy also allows a stratigraphic succession to be put into a time framework which in turn allows the depositional history and paleogeographic evolution to be interpreted against a background of base-level changes. Such interpretations provide the predictive aspect of sequence stratigraphy.

Below, I discuss how sequence stratigraphy is best viewed as a separate stratigraphic discipline rather than some all encompassing discipline which integrates data from all sources.

Stratigraphy and Stratigraphic Disciplines

Stratigraphy is the scientific discipline that studies layered rocks (strata) that obey Steno's Law of Superposition (younger strata

overlie older strata). The Law of Superposition allows a relative temporal ordering of stratigraphic units and surfaces at any location, and correlation of such entities between different localities permits a relative ordering of strata to be assembled for the entire Earth. Stratigraphy includes recognizing and interpreting the physical, biological, and chemical properties of strata and defining a variety of stratigraphic surfaces and units on the basis of vertical changes in these properties.

Each stratigraphic discipline focuses on a specific property of strata for unit definition, description, and interpretation. Vertical changes in that specific property of the strata allow the recognition and delineation of stratigraphic surfaces within that discipline and these are used both to define the boundaries of the units and to provide stand alone correlation surfaces. The stratigraphic disciplines of lithostratigraphy (changes in lithology) and biostratigraphy (changes in fossil content) have dominated stratigraphic analysis since the time of William Smith. However, over the past 50 years, other properties of strata have been used to define new stratigraphic disciplines, each with its own specific category of stratigraphic units and surfaces. The "late comers" which have been adopted are magnetostratigraphy (changes in magnetic properties), chemostratigraphy (changes in chemical properties), and sequence stratigraphy (changes in depositional trend).

For each stratigraphic discipline, the recognized changes in the specific property which characterizes that discipline are correlated (matched on the basis of similar character and stratigraphic position) from one locality to the next and become the boundaries of a series of units. Changes in the various rock properties often can be extended over wide areas so as to allow the definition of a set of regional units. Furthermore, it is useful to determine the time relationships of a stratigraphic succession. To accomplish this, stratigraphic boundaries which are used for correlation have to be evaluated in terms of their relationship to time. Each stratigraphic surface represents an episode of change which occurred over a discrete interval of time and thus each has a degree of diachroneity over its extent. To undertake a chronostratigraphic analysis (i.e., to put the



succession into a time framework), each correlated surface has to be evaluated in terms of how close it approximates a time surface.

Surfaces that have low diachroneity, that is, they developed over a short time interval, are the closest approximation to time surfaces we have and they have the most utility for the construction of stratigraphic cross sections and time frameworks. Such boundaries were classically determined by biostratigraphy with rare contributions from lithostratigraphy (e.g., bentonites). More recently, magnetostratigraphy and chemostratigraphy have been employed to contribute to the construction of an approximate time framework. The main problems with using these stratigraphic disciplines in petroleum geology are that they are very time consuming, require highly trained specialists, and often involve large costs. Furthermore, they also require rock samples from either outcrop or core that are rarely available for most subsurface studies. All these constraints have greatly limited the application of these types of stratigraphic analysis in day-to-day petroleum exploration. As discussed below, sequence stratigraphy does not have the drawbacks and constraints that severely limit the use of the other stratigraphic disciplines for building an approximate time correlation framework for subsurface successions.

Sequence Stratigraphy - The recognizable property change of strata that allows sequence stratigraphic surfaces to be defined and delineated, and provides the rationale for sequence stratigraphy being a distinct stratigraphic discipline, is a change in depositional trend. Examples of changes in depositional trend include the change from sedimentation to erosion and/or starvation, a change from a coarsening-upward trend to a fining-upward one and vice-versa, and a change from a shallowing-upward trend to a deepening-upward one and vice-versa. Such changes are based on relatively objective observations and interpretations and they are the main ones used to define specific sequence stratigraphic surfaces. The latter two changes in trend are often used to interpret a change from a regressive trend to a transgressive trend and vice versa. Much more interpretive changes in depositional trend – the change from base-level fall to base-level rise and vice-versa – are also sometimes used in sequence stratigraphy but, as will be discussed, these are very difficult to apply to many datasets.

These changes in depositional trend are used to define and delineate specific types of sequence stratigraphic surfaces (e.g., subaerial unconformity for the change from

sedimentation to subaerial erosion) and these surfaces in turn are used for correlation and for defining the specific units of sequence stratigraphy (e.g., a sequence). Given the above, we can say “Sequence Stratigraphy consists of:

- 1) the recognition and correlation of stratigraphic surfaces which represent changes in depositional trends in the rock record and
- 2) the description and interpretation of resulting, genetic stratigraphic units bound by those surfaces.”

Each surface of sequence stratigraphy is characterized by a specific combination of physical characteristics, which are based on:

- 1) sedimentological criteria of the surface itself and the strata above and below it, and
- 2) geometric relationships between the surface and strata above and below it.

Thus the types of data available for a sequence stratigraphic analysis must allow the facies of the succession to be reasonably interpreted and the stratal geometries to be determined. Data from other stratigraphic disciplines such as biostratigraphy and chemostratigraphy can also contribute to surface recognition (e.g., help determine stratal geometries) but cannot be used for surface characterization.

For each stratigraphic discipline, it is useful, but not essential, to have a solid theoretical foundation which links the generation of the various surfaces in that discipline to phenomena which occur on our planet. For example, surfaces in biostratigraphy represent changes in fossil content that are due mainly to a combination of evolution and shifting environments of deposition. It must be noted that biostratigraphy flourished long before the theory of evolution was developed. Most sequence stratigraphic surfaces were recognized in the rock record and used for correlation long before a theory was developed to explain their existence. Eventually it was postulated that these sequence stratigraphic surfaces are generated by the interaction of sedimentation with relative changes in base level and this theoretical model is widely accepted today. In the next article I will describe the historical development of both the empirical observations and the theoretical underpinnings which have led to the current state of sequence stratigraphy.



Practical Sequence Stratigraphy II

Historical Development of the Discipline: The First 200 Years (1788-1988)

| by Ashton Embry

In my initial article in this series, I emphasized that sequence stratigraphy is one of a number of stratigraphic disciplines with each discipline characterized by a specific type of stratigraphic surface used for correlation and unit definition. I defined sequence stratigraphy as 1) the recognition and correlation of stratigraphic surfaces which represent changes in depositional trends in the rock record and 2) the description and interpretation of resulting, genetic stratigraphic units bound by those surfaces. Sequence stratigraphic thought has traveled a long and bumpy road to arrive at our current understanding of the discipline and that succinct definition.

In this article and the following one, I will describe the history of sequence stratigraphic analysis from its first vestiges, which were part of the birth of modern geology, to its current state, which is vibrant but burdened by invisible surfaces, an overblown jargon, and questionable methodologies.

Early Work

Sequence stratigraphy has been slowly evolving ever since the late 1700s when James Hutton, the father of modern geology, first recognized an unconformity as a specific type of stratigraphic surface and realized that it represented a substantial time gap. From that time onward, unconformities were seen as very useful stratigraphic surfaces for correlation and bounding stratigraphic units and for unraveling geological history. Because an unconformity represents a change in depositional trend, it is one of the main surfaces employed in sequence stratigraphy. Thus, it can be said that sequence stratigraphy began at the moment Hutton conceptualized an unconformity.

During the 1800s, debate began on whether unconformities were generated by a rise of the land surface (tectonics) or by a fall in sea level (eustasy). By the end of the century the tectonics interpretation was favoured and unconformities, and the episodes of diastrophism they represented, were seen as the key to global correlations. In the first two decades of the 20th century, key relationships associated with unconformities were recognized. Grabau

(1906) described stratigraphic truncation below the unconformity and stratigraphic onlap above it. Barrell (1917) provided the first deductive model for sequence stratigraphy when he introduced the concept of base level, an abstract surface which acts as the ceiling for sedimentation, and proposed that cycles of base-level rise and fall produced repeated unconformities in the stratigraphic record. Notably, he also defined a diastem which, in contrast to an unconformity, is a stratigraphic surface which represents an insignificant gap in the stratigraphic record. Unfortunately Barrell was struck down by the Spanish Flu soon after his paper on base level and unconformities was published, and his "ahead of their time" concepts lay in limbo for a long time.

In the 1930s small-scale, unconformity bounded units were recognized in the Carboniferous strata of the mid-continent and were called cyclothems (Weller, 1930; Wanless and Shepard, 1936). We now know that these cyclothems were generated by numerous eustatic rises and fall in sea level related to the waxing and waning of the Gondwana glaciers. However, at the time of their recognition, there was fierce debate as to whether cyclothems were the product of tectonics or eustasy.

Sloss and Wheeler

Sequence stratigraphy began as a specific stratigraphic discipline almost 60 years ago when Sloss et al. (1949) coined the term sequence for a stratigraphic unit bounded by large-magnitude, regional unconformities which spanned most of North America. Krumbein and Sloss (1951, p. 380-381) elaborated on the concept of a sequence which they characterized as a "major tectonic cycle." It was not until the early 1960s that Sloss (1963) fully developed the concept and named six sequences which occurred throughout North America. Sloss (1963) interpreted that the unconformities which bound his sequences were generated by repeated episodes of continent-wide, tectonic uplift.

After Sloss et al. (1949) gave us the concept of a sequence, Harry Wheeler published a series of papers (Wheeler and Murray, 1957; Wheeler 1958, 1959, 1964a, 1964b) which

used theoretical deduction to provide a foundation for the development of unconformities and consequent sequences. The main parameters in Wheeler's model, like that of Barrell (1917), were sediment supply and rising and falling base level (base-level transit cycles). Wheeler (1958, 1959) provided real-world examples of unconformity-bounded sequences to support his model. In most cases, the recognized unconformities were of smaller magnitude than the continent-wide unconformities of Sloss (1963) and many of the unconformities of Wheeler (1958, 1959) disappeared in a basinward direction. As illustrated by Wheeler (1958, Fig. 3), where one of the bounding unconformities disappeared, that specific sequence was no longer recognizable. Thus to Wheeler (1958), a sequence was a unit bounded by unconformities over its entire extent.

The result of defining a sequence as a unit bounded entirely by unconformities was that most sequences occurred only on the flanks of a basin where major breaks in the stratigraphic record were common and readily recognized. Nomenclatural problems occurred as unconformities appeared and disappeared along depositional strike and basinward and new sequences had to be recognized at every place this happened (Figure 2.1, page 4). Furthermore, unconformity bounded sequences had very limited value for subdividing the more central successions of a basin where breaks in the record were absent or very subtle.

In summary, by the mid 1960s, sequence stratigraphy was characterized by two separate approaches, one of data-driven empiricism as exemplified by the work of Sloss (1963) and the other of theoretical deduction as used by Wheeler (1958). Notably, both approaches came to a similar place, that of a sequence being a unit bounded by subaerial unconformities generated by base-level fall (tectonic uplift or eustatic fall).

The pre-modern era in sequence history came to a close in the mid 1960s with the publication of Kansas Geological Survey Bulletin 169 (Merriam, 1964) which summarized the concepts on cyclic sedimentation and unconformity



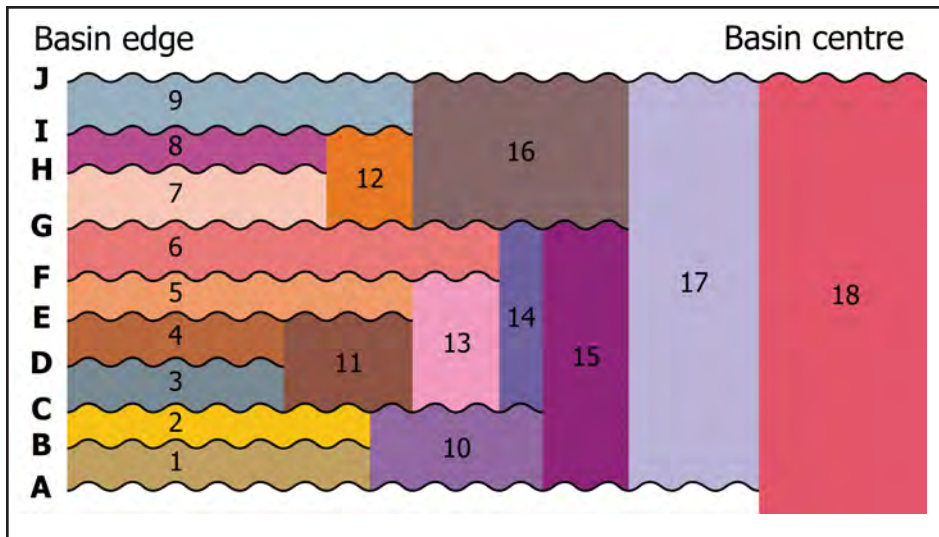

Figure 2.1. The occurrence of 10 unconformities on the basin margin allows 9 “unconformity-only” sequences to be defined. Because each unconformity extends a different distance into the basin, a new series of “unconformity-only” sequences has to be defined each time an unconformity disappears. Such a chaotic nomenclatural system and the lack of subdivision over much of the basin ensured that the “unconformity-only” sequences of Wheeler (1958) were not widely adopted.

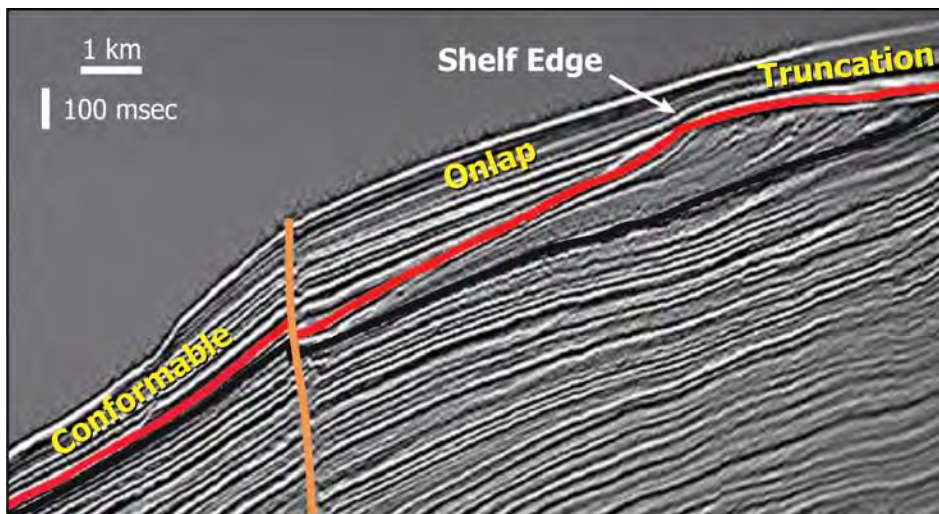

Figure 2.2. A seismically delineated sequence boundary (red line) exhibits a variety of specific stratigraphic relationships along its length indicating that different types of surfaces comprise the boundary. On the basin flank the boundary is characterized by truncation whereas further basinward it exhibits marine onlap. Toward the basin centre the boundary is a correlative conformity. Seismic line from Quaternary succession of the Gulf of Mexico, Desoto Canyon area (modified from Posamentier, 2003).

development up to that date. After this, interest in sequence stratigraphy waned as the focus of sedimentary geology switched to process sedimentology and facies models. In the mid 1970s a few new terms were introduced. Frazier (1974) named a unit bounded by marine starvation surfaces (today’s maximum flooding surfaces) a depositional complex and Chang (1976) renamed a sequence as defined by Sloss et al. (1949) as a synthem. Neither of these suggestions was embraced by the stratigraphic community and sequence stratigraphy remained in the closet until Exxon researchers published their revolutionary concepts and methods.

Peter Vail and Seismic Data

Interest in sequence stratigraphy was revived in 1977 with the publication of AAPG Memoir 26 on Seismic Stratigraphy (Payton, 1977). In this watershed publication, Peter Vail and his colleagues from Exxon used regional seismic lines as their primary data base and demonstrated that the sedimentary record consists of a series of units that are bound mainly by unconformities (Vail et al., 1977). This was accomplished on the reasonable assumptions that many seismic reflectors parallel stratal surfaces and that unconformities coincided with seismic reflectors at which other reflectors

terminated due to truncation, toplap, onlap, or downlap. In essence, Vail et al. (1977) used seismic data to delineate unconformities by way of the seismically imaged, geometric relationships of the strata.

A number of the Exxon researchers, including Peter Vail, had been graduate students under Larry Sloss and it is not surprising that the seismically determined, unconformity related units were termed “depositional sequences” by the Exxon scientists. On the basin flanks, a sequence-bounding reflector was characterized by truncation below and onlap above and appeared to be similar to the unconformity used by Sloss et al. (1949) and Wheeler (1958) to bound a sequence (i.e., an unconformity formed mainly by subaerial erosion). Of critical importance was the observation that the reflector that encompassed this truncation unconformity on the basin flanks could be traced into the more central areas of the basin where it had different character. In some areas the reflector exhibited no evidence of missing section and these portions were termed the correlative conformity part of the sequence boundary. More commonly, the reflector exhibited unconformable relationships characterized by either marine onlap or by marine downlap. Thus a sequence boundary, as delineated with seismic data, seemed to be a composite boundary characterized by a truncation unconformity on the basin flanks and by marine unconformities and stretches of correlative conformities in the more central portions of the basin (Figure 2.2). On the basis of these observations, Mitchum et al. (1977) proposed a new definition of a sequence – “a stratigraphic unit composed of a relatively conformable succession of strata bounded at its top and bottom by unconformities or correlative conformities.”

The new definition essentially revolutionized sequence stratigraphy. With it, the stratigraphic succession of a given basin could be subdivided into a series of sequences which could be recognized over most or all of a basin (Figure 2.3). The problems that had prevented the acceptance of the unconformity-only bounded sequences of Sloss (1963) and Wheeler (1958) were thus resolved and new life was breathed into sequence stratigraphy. Overall, the Exxon seismic data clearly demonstrated that sequence boundaries are key, regional correlation horizons and that sequences are the most practical units to use for stratigraphic subdivision if one wants to describe and interpret the depositional history of a stratigraphic succession. One of the most innovative aspects of the Vail et al. (1977) sequence boundary is that it is a composite of different types of stratigraphic

surfaces rather than one specific type of surface. It is this composite nature of a sequence boundary which allows sequences to be correlated over large areas of a basin and is the key to the great utility of such a boundary. One problem associated with the seismically delineated, composite sequence boundary was the uncertainty of the specific nature of the surface types which comprised a sequence boundary. Such uncertainty stems mainly from the poor vertical resolution of the seismic data which was available at the time Vail et al. (1977) were doing their studies. In most instances, individual reflectors comprised 20-30 metres of strata and thus the seismic data were not adequate to resolve the necessary details to confidently identify all the specific types of stratigraphic surfaces which were generating the reflectors that were designated as sequence boundaries on seismic sections. On the basis of truncation/onlap relationships, a reasonable interpretation was that subaerial unconformities formed the sequence boundaries on the basin flanks. However, it was very uncertain what specific types of stratigraphic surfaces formed the seismically determined, marine unconformities and the correlative conformities of the sequence boundaries farther basinward. Furthermore, in some cases, such as for the “downlap surface” or a toplap unconformity, it was uncertain whether or not the seismically imaged unconformity (apparent truncation of reflectors) was a real unconformity or was an artifact of the low seismic resolution (merging rather than terminating strata). This uncertainty regarding the specific types of stratigraphic surfaces which comprise a sequence boundary is still causing significant problems today.

The Rise of Sea Level

In addition to providing a new methodology and definition for sequence delineation, Vail et al. (1977) interpreted that the multitude of sequence boundaries they recognized on seismic data from many parts of the world were generated primarily by eustatic sea level changes. This interpretation stood in contrast to that of Sloss (1963), who had always emphasized tectonics as the prime driver of sequence boundary generation. As noted earlier, the debate of tectonics versus eustasy for unconformity generation began in the 19th century and it continues today. Importantly, the interpretation that eustasy was the driving force behind sequence generation led to the development of a deductive model for sequence generation which combined sinusoidal eustatic sea level change with a constant sediment supply and a basinward increasing subsidence rate. This model reproduced a number of the stratigraphic relationships seen on the

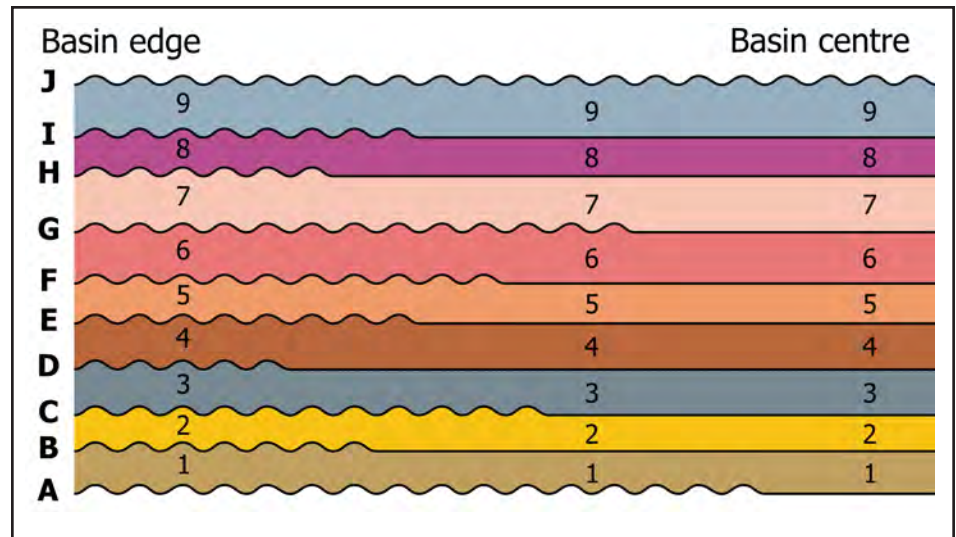

Figure 2.3. The same 10 unconformities as shown on Figure 2.1 are present on the basin flank and the same 9 depositional sequences are delineated. With Mitchum et al.'s (1977) addition of the “correlative conformity” to the definition of a sequence boundary, the same 9 sequences can be extended over the entire basin. This resolved the nomenclatural nightmare of “unconformity-only” sequences and the lack of subdivision in the central portions of a basin.

seismic sections such as basin flank unconformities associated with truncation and basin centre, condensed horizons associated with downlap. Because of this, the model was embraced by the Exxon scientists and became the centre piece of their next watershed publications on sequence stratigraphy (Wilgus et al., 1988). These papers, and the models and interpretations they advocated, formed the foundation for new sequence stratigraphic terminology and methods which could be applied to the rock record of well logs and outcrops as well as to seismic. In the next article in this series, I will discuss this revolutionary model which took sequence stratigraphy from correlating low-resolution seismic to interpreting high-resolution well log and outcrop stratigraphic sections. I will also put into context all the terminology and disagreements the Exxon sequence model has spawned over the past 20 years and I'll describe the alternative models and methods which have arisen during this time.

References

Barrell, J. 1917. Rhythms and the measurements of geologic time. *GSA Bulletin*, v. 28, p. 745-904.

Chang, K. 1975. Unconformity-bounded stratigraphic units. *GSA Bulletin*, v. 86, p. 1544-1552.

Frazier, D. 1974. Depositional episodes: their relationship to the Quaternary stratigraphic framework in the northwestern portion of the Gulf Basin. *Bureau of Economic Geology, University of Texas, Geological Circular 74-1*, 26 p.

Grabau, A. 1906. Types of sedimentary overlap. *GSA Bulletin*, v. 17, p. 567-636.

Krumbein, W. and Sloss, L. 1951. *Stratigraphy and sedimentation*. W. M. Freeman and Co. San Francisco, 495 p.

Merriam, D. (ed.) 1964. *Symposium on cyclic sedimentation*. Kansas Geological Survey, Bulletin 169 (2 volumes), 636 p.

Mitchum, R, Vail, P., and Thompson, S. 1977. Seismic stratigraphy and global changes in sea level, part 2: the depositional sequence as the basic unit for stratigraphic analysis. in: Payton, C. (ed.) *Seismic stratigraphy: application to hydrocarbon exploration*. AAPG Memoir 26, p. 53-62.

Payton, C. (ed.) 1977. *Seismic stratigraphy: applications to hydrocarbon exploration*. AAPG Memoir 26, 516 p.

Posamentier, H. 2003. A linked shelf-edge delta and slope-channel turbidite system: 3d seismic case study from the eastern Gulf of Mexico. in: Roberts, H., Rosen, N, Fillon, R., and Anderson, J. (eds.), *Shelf margin deltas and linked down slope petroleum systems*, Proceedings of the 23rd GCSSEM conference, p. 115-134.

Sloss, L. 1963. Sequences in the cratonic interior of North America. *GSA Bulletin*, v. 74, p. 93-113.

Sloss, L., Krumbein, W., and Dapples, E. 1949. *Integrated facies analysis*. in: Longwell, C. (ed.). *Sedimentary facies in geologic history*. Geological Society America, Memoir 39, p. 91-124.

Vail, P. et al. 1977. Seismic stratigraphy and global changes in sea level. in: Payton, C. (ed.) *Seismic stratigraphy: applications to hydrocarbon exploration*, AAPG Memoir 26, p. 49-212.



Weller, J.M. 1930. Cyclic sedimentation of the Pennsylvanian period and its significance. *Journal of Geology*, v. 38, p. 97-135.

Wheeler, H.E. 1958. Time stratigraphy. *AAPG Bulletin*, v. 42, p. 1208-1218.

Wheeler, H.E. 1959. Stratigraphic units in time and space. *American Journal Science*, v. 257, p. 692-706.

Wheeler, H.E. 1964a. Base level, lithosphere surface and time stratigraphy. *GSA Bulletin*. v. 75, p. 599-610.

Wheeler, H.E. 1964b. Base level transit cycle. in: Merriam, D.F. (ed.) *Symposium on cyclic sedimentation: Kansas Geological Survey, Bulletin 169*, p. 623-629.

Wheeler, H.E. and Murray, H. 1957. Base level control patterns in cyclothemic sedimentation. *AAPG Bulletin*, v. 41, p. 1985-2011.

Wanless, H. and Shepard, F. 1936. Sea level and climatic changes related to late Paleozoic cycles. *GSA Bulletin*, v. 47, p. 1177-1206.

Wilgus, C., Hastings, B.S., Kendall, C.G., Posamentier, H.W., Ross, C.A., and Van Wagoner, J.C. 1988. Sea level changes: an integrated approach. *SEPM Spec. Pub.* 42, 407 p.

Practical Sequence Stratigraphy III

Historical Development of the Discipline: The Last 20 Years (1988-2008)

by Ashton Embry

In the last article in this series, I looked at the first 200 years (1788 to 1988) of the development of sequence stratigraphy as a useful stratigraphic discipline for correlation, mapping, and interpreting depositional history. By 1988 we had a revised definition of a sequence which was a stratigraphic unit bounded by unconformities or correlative conformities (Mitchum et al, 1977). Because this definition was based mainly on observations from seismic data, there was considerable confusion as to what specific types of stratigraphic surfaces constituted a sequence boundary, especially the correlative conformities. The veil was lifted in 1988.

The Exxon Sequence Model

In 1988, the first, comprehensive sequence stratigraphic model was described in a series of papers authored by researchers from Exxon Corporation. These papers appeared in SEPM Special Publication 42 - Sea level Changes: An Integrated Approach (Wilgus et al., 1988) and they presented Exxon's methods, models, classification systems, and terminology for sequence stratigraphy. These papers also made clear how Exxon scientists delineated and correlated a sequence boundary from basin edge to basin centre. The Exxon work was based on a combination of theoretical modeling and empirical observations from seismic records, well-log cross-sections, and outcrop data.

The paper by Mac Jervey (Jervey, 1988) presented a quantitative, theoretical model for sequence development and it greatly expanded the concepts on the interaction of sedimentation and base-level change which had been first explored by Barrell (1917) and Wheeler (1958). Jervey's model used sinusoidal sea level change, subsidence which increased basinward, and a constant sediment supply as its input parameters. The model predicted that, during a cycle of base-level rise and fall (see Jervey, 1988, Fig. 9), three different sedimentary units would be sequentially developed and that these would constitute a sequence. These were an initial, progradational (regressive) unit deposited during initial slow base-level rise, a middle, retrogradational (transgressive) unit

deposited during fast base-level rise and an upper, progradational (regressive) unit deposited as base-level rise slowed and during the subsequent interval of base-level fall.

Depositional Sequence Boundaries

On the basis of Jervey's concepts and the stratigraphic geometries observed on regional seismic profiles, Exxon scientists (Baum and Vail, 1988; Posamentier et al., 1988; Posamentier and Vail, 1988) developed a theoretical sequence stratigraphic model for a shelf/slope/basin depositional setting (Figure 3.1). In this model, a depositional sequence is bound by subaerial unconformities on the basin margin and by correlative surfaces farther basinward.

Two types of depositional sequence boundaries, originally defined by Vail and Todd (1981), were included in the Exxon model. A Type 1 sequence boundary encompassed a major subaerial unconformity which extended from the basin edge, past the shelf margin and onto the upper slope. Basinward, the boundary was called a correlative conformity (see Baum and Vail, 1988, Fig. 1) and was extended along the base of the turbidite facies which occupied the basin floor and overlapped the lower slope (Figure 3.1).

A Type 2 sequence boundary comprised a relatively minor subaerial unconformity which did not reach the shelf edge. It was confined mainly to the proximal portion of the shelf often within nonmarine strata (Posamentier and Vail, 1988, Fig. 18). The basinward extension of the Type 2 sequence boundary (correlative conformity) was along a chronostratigraphic surface equal to the time of start base-level rise (time of maximum rate of eustatic fall) (Baum and Vail, 1988, Fig. 1; Van Wagoner et al., 1988, Fig. 4; Posamentier et al., 1988, Fig 6).

Systems Tracts

The depositional sequence was divided into three component units which were termed systems tracts. These approximated the three units that Jervey (1988) had deduced as being part of a sequence that develops during a sinusoidal, base-level rise/fall cycle. The lower unit was called the lowstand systems tract (LST) and it consisted of a basal unit of turbidites overlain by a progradational wedge which overlapped the upper slope portion of the sequence bounding unconformity. The LST was bound by the sequence boundary below and the transgressive surface above (Figure 3.1). The transgressive surface, as defined by the Exxon workers, marks the change from progradational sedimentation below to retrogradational sedimentation

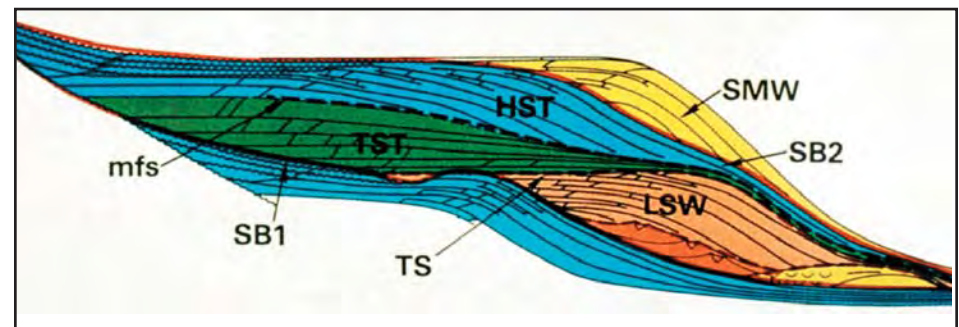

Figure 3.1. The Exxon depositional sequence model of 1988. The lower boundary is a Type 1 sequence boundary (SB1) and it coincides with a subaerial unconformity on the shelf and upper slope and with the base of submarine fan deposits in the basin. The upper boundary is a Type 2 boundary (SB2) and it coincides with a subaerial unconformity on the shelf and with a time surface (clinoform) equivalent to the start base-level rise farther basinward.

The transgressive surface (TS) and maximum flooding surface (mfs) occur within the sequence and allow it to be subdivided into three systems tracts – lowstand (LSW), transgressive (TST) and highstand (HST). The systems tract which directly overlies a Type 2 sequence boundary is called a shelf margin systems tract (SMW). Modified from Baum and Vail (1988, Fig. 1).



above. The LST was interpreted to have developed during most of base-level fall and the early part of rise.

The middle unit was called the transgressive systems tract (TST) and it consisted of retrogradational sediments that overstepped the LST and overlapped the shelfal portion of the subaerial unconformity. The TST was bound by the transgressive surface below and the maximum flooding surface (MFS) above (Figure 3.1, page 7). The MFS was defined as the surface of sequence stratigraphy that marks the change from retrogradational sedimentation below to progradational sedimentation above. The transgressive systems tract was interpreted to have developed during high rates of base-level rise.

The upper systems tract was termed the highstand systems tract (HST) and it consisted of progradational sediments which were capped by a subaerial unconformity (sequence boundary on the basin flanks and by the correlative surfaces farther basinward (Figure 3.1, page 7). The HST was interpreted to have developed during the waning stage of base-level rise and the early portion of base-level fall. The wedge of strata above the Type 2 sequence boundary and below the next transgressive surface was called the shelf margin systems tract (SMW) (Figure 3.1 page 7).

Van Wagoner et al., (1988) applied the same terminology to siliciclastic sediments deposited in a ramp setting (see their Fig. 3). In this case the sequence boundary was extended basinward from the termination of the unconformity along the facies contact between shallow water sandstones above and marine shales below and then into the offshore shales. Van Wagoner et al., (1988) also defined a small-scale sequence stratigraphic unit termed a parasequence. It was defined as a relatively conformable succession of genetically related beds or bedsets bound by marine flooding surfaces. A marine flooding surface was defined as a surface which separates older from younger strata across which there is evidence of an abrupt deepening.

There can be no doubt that the Exxon sequence stratigraphic work was a very significant and important contribution to sedimentary geology because it transformed sedimentology from a static discipline which focused on facies models to a dynamic discipline in which facies developed in a framework of shifting base level. It also provided a comprehensive classification system for sequence stratigraphy and elucidated the linkage between changing base level and the development of specific surfaces of sequence stratigraphy and the units they

enclosed. Thus it is not surprising the model was enthusiastically embraced by the industrial and academic sedimentary geology communities.

The Exxon sequence model, and accompanying methods and classification systems were the product of a combination of theoretical deduction and empirical observations. Most of the stratigraphic surfaces employed in their work were material-based surfaces which were defined on the basis of physical criteria. However the model also included an abstract time surface equated with the start of base-level rise. As will be discussed in future articles, the inclusion of a chronostratigraphic surface has caused some problems. Their 1988 sequence model has a few other inconsistencies and these also will be discussed in subsequent articles.

Genetic Stratigraphic Sequence

The next contribution to sequence stratigraphic classification came with Galloway's (1989) proposal that a sequence be bound by maximum flooding surfaces ("downlap surfaces"), the prominent stratigraphic surface at the top of the TST of Exxon (Figure 3.2). Such a sequence was a completely different stratigraphic entity from the depositional sequence of the Exxon model, although it did fit Mitchum et al.'s (1977) general definition of a sequence because the distal portion of a MFS is often an unconformity produced mainly by

sediment starvation. The conformable, proximal portion of the MFS is a suitable correlative conformity of the sequence boundary. Galloway (1989) named a sequence bounded by MFSs a genetic stratigraphic sequence (GSS).

In contrast to the Exxon depositional sequence, which was in part based on Jervey's (1988) deductive model, Galloway's genetic stratigraphic sequence was purely an empirical construct based on his extensive work on the Tertiary strata of the Gulf Coast and the observation that MFSs are usually the most readily recognizable sequence stratigraphic surfaces in marine successions.

Revision of the Exxon Model

Hunt and Tucker (1992) were the first authors to modify the original 1988 Exxon sequence model and they focused on the placement of the Type I depositional sequence boundary. In the Exxon model, strata deposited during base-level fall were placed below the unconformable sequence boundary on the basin flanks and above the sequence boundary in more basinward localities. Hunt and Tucker (1992) correctly asserted that the depositional sequence boundary in the basin must lie on top, rather than below, the strata deposited during fall (i.e., the submarine fan turbidites) to ensure a single, through-going sequence boundary is delineated. Notably Jervey (1988, Fig. 20), in his deductive model of sequence development, also put the turbidite facies below the sequence

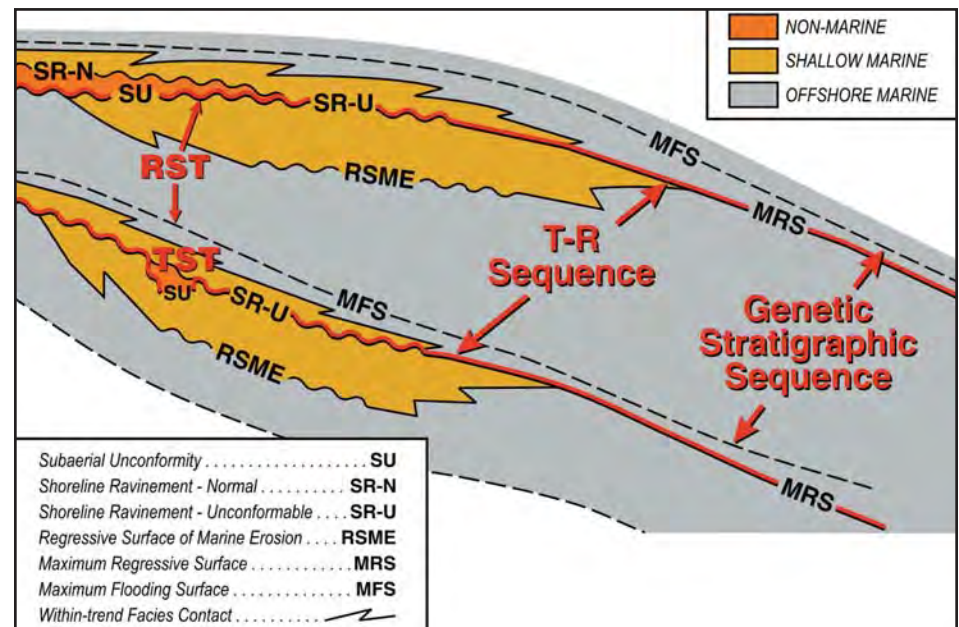

Figure 3.2. This schematic cross-section illustrates the boundaries of both the genetic stratigraphic sequence (GSS) of Galloway (1989) (MFS boundary) and the T-R sequence of Embry (1993) (composite SU/SR-U/MRS boundary). Both of these sequence types are based solely on empirical observations and this contrasts with the 1988 Exxon depositional sequence model which is substantially derived from theoretical deduction. Embry (1993) subdivided a T-R sequence into a transgressive systems tract (TST) and a regressive systems tract (RST) on the basis of the enclosed MFS. These systems tracts can be readily applied to a GSS.

boundary rather than above it. In their modification of the Exxon model, Hunt and Tucker (1992) proposed that the basinward extension of the sequence boundary be along the time surface at the start of base-level rise which they called the correlative conformity (CC) (Figure 3.3).

They also added a fourth systems tract in the uppermost portion of a sequence and called it the forced regression systems tract (FRST). Their FRST was bound above by the sequence boundary (SU on the flank, CC in the basin) and below by the newly defined, "basal surface of forced regression" (BSFR) which equated to a time surface equal to the time of start base-level fall (Figure 3.3).

With such a definition, the FRST encompassed all the strata deposited during base-level fall. The LST of Hunt and Tucker (1992) was restricted to the strata between the CC below and the transgressive surface above and represented the progradational strata deposited during the initial phase of slow base-level rise that occurred in the Jervey model (Figure 3.3). Thus the LST of Hunt and Tucker (1992) was equivalent to only part of the LST of the Exxon Type 1 sequence but was entirely equivalent to the SMW of the Exxon Type 2 sequence.

To complicate matters even more, Nummedal et al., (1993) referred all strata deposited during basin level fall as the falling stage systems tract (FSST). The four systems tract, sequence model of Hunt and Tucker (1992) was elaborated on and clearly illustrated by Helland-Hansen and Gjelberg (1994) who ably demonstrated the theoretical logic of such a classification system.

T-R Sequence

In 1993, due to my inability to objectively apply the Exxon sequence stratigraphic methods and classification system to very well exposed strata of the nine km-thick Mesozoic succession of the Sverdrup Basin of Arctic Canada, I suggested another possible combination of surfaces which would satisfy the basic definition of a sequence boundary (Embry, 1993; Embry and Johannessen, 1993).

Following the work of Wheeler (1958) and Exxon (Posamentier et al., 1988), a subaerial unconformity (SU) was used as a sequence boundary on the basin flank with the proviso that in many settings the SU is partially or totally replaced by a shoreline ravinement (SR-U) which represents the landward portion of the transgressive surface of Exxon workers. The sequence boundary was extended basinward from the termination of the basin flank unconformity (SU/SR-U) along the maximum regressive surface (MRS)

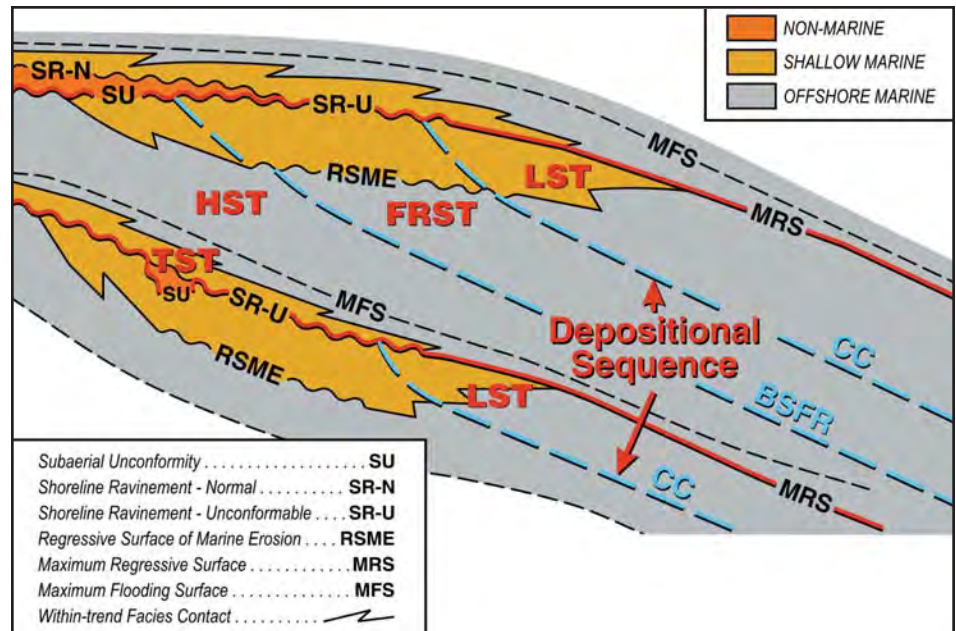

Figure 3.3. The depositional sequence and component systems tracts of Hunt and Tucker (1992). Hunt and Tucker (1992) advocated for the utilization of two time surfaces – the basal surface of forced regression (BSFR) (equals start base-level fall) and the correlative conformity (CC) (equals start base-level rise) for delineating sequence and systems tract boundaries. Their depositional sequence boundary is a composite of the subaerial unconformity on the basin flank and the correlative conformity time surface farther basinward. Note that the forced regressive systems tract (FRST), which was defined by Hunt and Tucker (1992), is bound by both time surfaces and represents all the strata deposited during base-level fall. The other systems tracts are lowstand (LST), transgressive (TS) and highstand (HST).

which represents the basinward, conformable portion of the transgressive surface (Figure 3.2).

Such a boundary was theoretically reasonable because the landward termination of the maximum regressive surface joins the basinward termination of the shoreline ravinement. Thus the composite of the SU, SR-U and MRS forms one, single through-going sequence boundary which can be recognized with objectivity from basin edge to basin centre. The unit bound by this newly defined sequence boundary was called a T-R sequence because the sequence boundary separated strata deposited during regression below from transgressive strata above.

The T-R sequence was divided into two systems tracts: a transgressive systems tract (TST) bounded by the sequence boundary below and the MFS above and a regressive systems tract (RST) bounded by the MFS below and the sequence boundary above (Figure 3.2). Notably, like Galloway's (1989) GSS, a T-R sequence was entirely an empirical construct based on observations of subsurface sections and extensive, very well exposed outcrops.

Another Depositional Sequence Boundary

Another proposal for defining a depositional sequence boundary was made by

Posamentier and Allen (1999). They suggested using only a portion of the subaerial unconformity as the sequence boundary and then extending the boundary basinward along the time surface at the start of fall; the BSFR as defined by Hunt and Tucker (1992) (Posamentier and Allen, 1999, Fig. 2.31) (Figure 3.4, page 10).

As illustrated by Posamentier and Allen (1999), the juncture between the SU and the BSFR occurs well landward of the basinward termination of the SU (Figure 3.4, page 10). They subdivided such a sequence into three systems tracts – LST, TST, and HST – and these were defined essentially in the same way as those used for the Exxon Type 1 sequence of Posamentier and Vail (1988). Posamentier and Allen (1999) also suggested that the concept of a Type 2 sequence (boundary) be abandoned.

Summary

In summary, over the past 20 years, different models for sequence boundary delineation and for the subdivision of a sequence into systems tracts have been proposed. This has resulted in considerable confusion and miscommunication as different authors apply different sequence models and terminology in their study areas. In some cases the same term is used for different entities (e.g., the LST of Posamentier and Allen (1999) versus the LST of Hunt and Tucker (1992)). In other



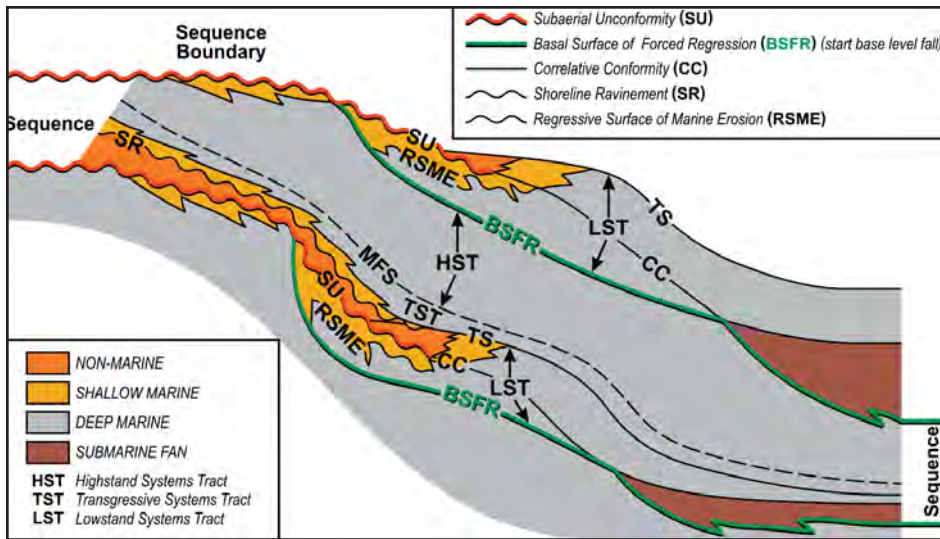

Figure 3.4. The depositional sequence boundary of Posamentier and Allen (1999). This proposed sequence boundary consists of only part of the subaerial unconformity (SU) and is extended basinward along the basal surface of forced regression (the time surface at the start of base-level fall). Note that a substantial portion of the subaerial unconformity lies within the sequence. The sequence is divided into the same three systems tracts as recognized for the 1988 Type I sequence model of Exxon.

cases different terms are used for the same entity (e.g., the FRST of Hunt and Tucker (1992) and the FSST of Nummedal et al., (1993) for all strata deposited during base-level fall). Such nomenclatural chaos is not conducive for effective communication.

Most importantly, the different proposals for sequence models and classification systems have not been comprehensively compared so as to determine the relative pros and cons of each one. Such a review would help workers select the most appropriate sequence stratigraphic classification system for their studies.

In following articles in this series, I will build sequence stratigraphic methods and classification systems from the bottom up. I will also review a variety of classifications systems with regards to applicability to real world situations encountered by petroleum geologists. In the next few articles we will look at the various surfaces of sequence stratigraphy which have been defined and each will be evaluated in terms of their usefulness for correlation and for bounding sequence stratigraphic units.

References

Barrell, J. 1917. Rhythms and the measurements of geologic time. *GSA Bulletin*, v. 28, p. 745-904.

Baum, G. and Vail, P. 1988. Sequence stratigraphic concepts applied to Paleogene outcrops, Gulf and Atlantic Basins. In: *Sea level changes: an integrated approach*. C. Wilgus, B.S. Hastings, C.G. Kendall, H.W. Posamentier, C.A. Ross, and J.C. Van Wagoner (eds.). *SEPM Special Publication 42*, p. 309-327.

Embry, A.F. 1993. Transgressive-regressive (TR) sequence analysis of the Jurassic succession of the Sverdrup Basin, Canadian Arctic Archipelago. *Canadian Journal of Earth Sciences*, v. 30, p. 301-320.

Embry, A.F. and Johannessen, E.P. 1993. TR sequence stratigraphy, facies analysis and reservoir distribution in the uppermost Triassic-Lower Jurassic succession, western Sverdrup Basin, Arctic Canada. In: *Arctic Geology and Petroleum Potential*. T. Vorren, E. Bergsager, O.A. Dahl-Stammes, E. Holter, B. Johansen, E. Lie, and T.B. Lund (eds.). *NPF Special Publication 2*, p. 121-146.

Galloway, W. 1989. Genetic stratigraphic sequences in basin analysis I: architecture and genesis of flooding surface bounded depositional units. *AAPG Bulletin*, v. 73, p. 125-142.

Helland-Hansen, W., and Gjelberg, J. 1994. Conceptual basis and variability in sequence stratigraphy: a different perspective. *Sedimentary Geology*, v. 92, p. 1-52.

Hunt, D. and Tucker, M. 1992. Stranded parasequences and the forced regressive wedge systems tract: deposition during base-level fall. *Sedimentary Geology*, v. 81, p. 1-9.

Jervey, M. 1988. Quantitative geological modeling of siliciclastic rock sequences and their seismic expression. In: *Sea level changes: an integrated approach*. C. Wilgus, B.S. Hastings, C.G. Kendall, H.W. Posamentier, C.A. Ross, and J.C. Van Wagoner (eds.). *SEPM Special Publication 42*, p. 47-69.

Mitchum, R., Vail, P., and Thompson, S. 1977. Seismic stratigraphy and global changes in sea level, part

2: the depositional sequence as the basic unit for stratigraphic analysis. In: *Seismic stratigraphy: application to hydrocarbon exploration*. C. Payton (ed.). *AAPG Memoir 26*, p. 53-62.

Nummedal, D., Riley, G., and Templet, P. 1993. High resolution sequence architecture: a chronostratigraphic model based on equilibrium profile studies. In: *Sequence stratigraphy and facies association*. H. Posamentier, C. Summerhayes, B. Haq, and G. Allen (eds.). *International Association of Sedimentologists, Special Publication 18*, p. 55-68.

Posamentier, H., Jervey, M., and Vail, P. 1988. Eustatic controls on clastic deposition I: conceptual framework. In: *Sea level changes: an integrated approach*. C. Wilgus, B.S. Hastings, C.G. Kendall, H.W. Posamentier, C.A. Ross, and J.C. Van Wagoner (eds.). *SEPM Special Publication 42*, p. 109-124.

Posamentier, H. and Vail, P. 1988. Eustatic controls on clastic deposition II- sequence and systems tract models. In: *Sea level changes: an integrated approach*. C. Wilgus, B.S. Hastings, C.G. Kendall, H.W. Posamentier, C.A. Ross, and J.C. Van Wagoner (eds.). *SEPM Special Publication 42*, p. 125-154.

Posamentier, H. and Allen, G. 1999. Siliciclastic sequence stratigraphy – concepts and applications. *SEPM Concepts in Sedimentology and Paleontology*, # 7, 210 pp.

Vail, P. and Todd, R. 1981. Northern North Sea Jurassic unconformities, chronostratigraphy and sea-level changes from seismic stratigraphy. In: *Petroleum Geology of the Continental Shelf of Northwest Europe*. L. Illing and G. Hobson (eds.). Heyden and Son, Ltd., London, p. 216-236.

Van Wagoner, J.C., Posamentier, H.W., Mitchum, R.M., Vail, P.R., Sarg, J.F., Loutit, T.S., and Hardenbol, J. 1988. An overview of the fundamentals of sequence stratigraphy and key definitions. In: *Sea level changes: an integrated approach*. C. Wilgus, B.S. Hastings, C.G. Kendall, H.W. Posamentier, C.A. Ross, and J.C. Van Wagoner (eds.). *SEPM Special Publication 42*, p. 39-46.

Wheeler, H.E. 1958. Time stratigraphy. *AAPG Bulletin*, v. 42, p. 1208-1218.

Wilgus, C., Hastings, B.S., Kendall, C.G., Posamentier, H.W., Ross, C.A., and Van Wagoner, J.C. (eds). 1988. *Sea level changes: an integrated approach*. *SEPM Spec. Pub. 42*, 407 p.

Practical Sequence Stratigraphy IV

The Material-based Surfaces of Sequence Stratigraphy, Part 1: Subaerial Unconformity and Regressive Surface of Marine Erosion

by Ashton Embry

The fundamental building blocks of sequence stratigraphy are the various sequence stratigraphic surfaces that are defined and used for correlation and for bounding units. As discussed in the first article in this series, sequence stratigraphic surfaces represent changes in depositional trend and this distinguishes them from surfaces of other stratigraphic disciplines which represent changes in different observable properties of strata.

Before describing various surfaces in detail, a few generalities about surfaces are required. First of all, there are two distinctly different types of sequence stratigraphic surfaces in use today – material-based and time-based.

A **material-based** surface is defined on the basis of observable physical characteristics which include 1) the physical properties of the surface and of overlying and underlying strata and 2) the geometrical relationships between the surface and the underlying and overlying strata.

A **time-based surface** in sequence stratigraphy is defined on the basis of an interpreted, site-specific event related to a change in either the direction of shoreline movement (e.g., landward movement to seaward movement) or the direction of base-level change (e.g., falling base level to rising base level).

Surfaces are also described in terms of their relationship to the interpreted time gap across the surface. A surface across which there is a large, significant time gap as evidenced by the missing stratigraphic surfaces (e.g., truncation, onlap) is called an **unconformity**. If the time gap is very minor and is inferred mainly on the basis of a scoured and/or abrupt contact rather than on missing surfaces across the contact, the surface is called a **diastem**. If there is no inferred time loss across the surface, it is referred to as a **conformity**. Notably, different portions of a single surface type can exhibit different relationships to time (e.g., one portion can be conformable and

another portion unconformable with yet another portion being diastemic). Finally, surfaces are often interpreted in terms of their relationship to time over parts or all of their extent, that is, the relationship between the surface and time surfaces. If a given surface is conformable and the same age over its entire extent, it is a time surface. However, no material-based, conformable surface is equivalent to a time surface because the generation of such a surface is always dependent in part on sedimentation rate. This factor always varies in space and time, ensuring all conformable, material-based surfaces will develop over an interval of time and will always exhibit some diachroneity (i.e., time surfaces will pass through them).

Surfaces which develop over an extended interval of time such that time surfaces cross them at a high angle are classed as being **highly diachronous**. Those which develop over a relatively short time interval such that time lines cross them at a low angle are referred to as having **low diachroneity**. In some cases, time surfaces do not cross a surface but rather terminate against it (e.g., truncation, onlap) (Figure 4.1). Such a surface is either an unconformity or a diastem and is referred to as a **time barrier**. Wherever a surface is a time barrier, all strata below it are entirely older than all strata above it.

It must be noted that some unconformities or diastems are diachronous and time surfaces pass through them (offset) rather than terminating against them. Once again, a single surface can exhibit more than one relationship time over its extent (e.g., a highly diachronous diastem over one portion and a time barrier unconformity over another)

The six, material-based surfaces of sequence stratigraphy (Embry, 1995, 2001) in common use for correlation and/or as a unit boundary are:

- 1) Subaerial unconformity,
- 2) Regressive surface of marine erosion,
- 3) Shoreline ravinement,
- 4) Maximum regressive surface,
- 5) Maximum flooding surface, and
- 6) Slope onlap surface.

Importantly, each of these surfaces is characterized by a combination of observable attributes that allow it to be distinguished from other stratigraphic surfaces and allow for its recognition by objective criteria. In this article, the first two of these surfaces are described and interpreted as to their origin, their relationship to time, and their potential usefulness for correlation and bounding a sequence stratigraphic unit. The remaining material-based surfaces, as well

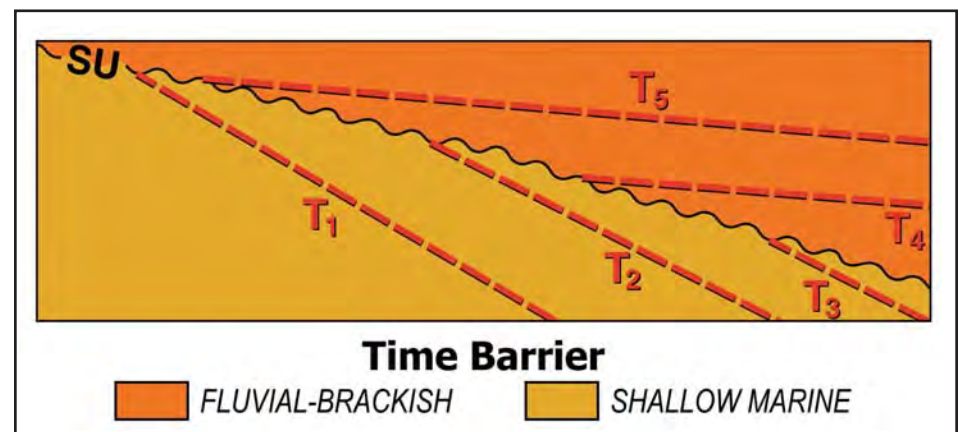

Figure 4.1. Time surfaces terminate at the unconformity that is a time barrier. The time surfaces below the unconformity are truncated and they onlap on top of the unconformity. All the strata below the unconformity are entirely older than all the strata above.



as time-based surfaces, will be discussed in subsequent articles.

Subaerial Unconformity (SU)

The subaerial unconformity is an important, sequence stratigraphic surface and was the surface used to empirically define a sequence in the first place (Sloss et al., 1949). It was first recognized through observation over 200 years ago and James Hutton's discovery / recognition of the Silurian / Devonian subaerial unconformity at Siccar Point, Scotland is legendary. The defining attributes of a subaerial unconformity are an erosive surface or weathering zone (e.g., paleosol, karst) overlain by nonmarine/brackish marine strata, and the demonstration that it represents a significant gap in the stratigraphic record (Figure 4.2). Any type of strata can lie below. Shanmugan (1988) elaborates on the physical characteristics of a subaerial unconformity.

It is worth emphasizing that nonmarine to brackish strata are required to overlie a subaerial unconformity. When marine strata overlie strata that had been formerly exposed and eroded, the surface marking the contact is not a subaerial unconformity. There is little doubt that an SU once overlaid the eroded strata but it is no longer present having been eroded during the passage of marine waters over it. Most often the remaining unconformable surface is a shoreline ravinement although other surfaces can potentially erode through and thus replace a subaerial unconformity as the surface marking a major gap in the succession.

The occurrence of a significant stratigraphic gap across a subaerial unconformity is critical for its recognition because this establishes the unconformable nature of the surface. Importantly, this allows a subaerial unconformity to be distinguished from subaerial diastems which are scoured contacts at the base of fluvial channel strata and which are much more common in the record. Such subaerial diastems originate through channel migration on a flood plain and are highly diachronous, diastemic surfaces which harbour only a very minor time gap at any locality.

To demonstrate the presence of a significant time gap beneath an SU, it is usually necessary to show that truncated strata lie below the surface. The occurrence of onlapping nonmarine strata above the surface adds further support to such an interpretation. These stratigraphic relationships are most readily seen on seismic data integrated with facies data from wells (Vail et al., 1977) although sometimes such seismically determined relationships are not real and are an artifact of the seismic parameters

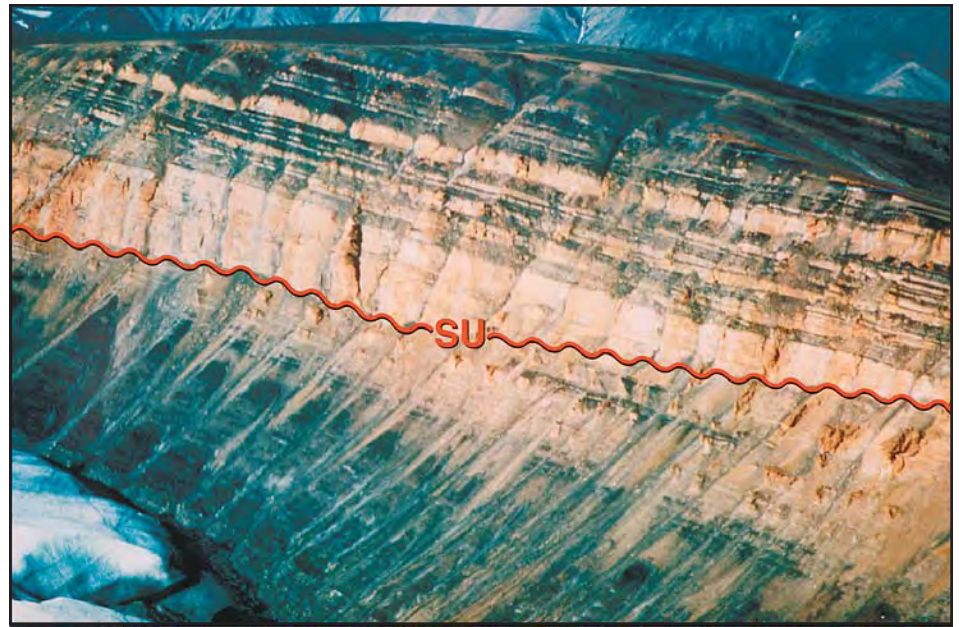

Figure 4.2. Outcrop of Lower Cretaceous strata on east central Axel Heiberg Island. The surface labeled SU is an abrupt scour surface beneath fluvial channel strata. The surface truncates strata below and is overlain by fluvial strata above. It has all the characteristics of a subaerial unconformity and is interpreted as such. Regional correlations indicate major truncation below this surface confirming its interpretation as an SU.

(Cartwright et al., 1993; Schlager, 2005; Janson et al., 2007).

The geometrical relationships (truncation, onlap) which help to delineate an SU can also often be determined on cross sections of well log and/or outcrop data (Figure 4.3). Data from other stratigraphic disciplines, especially biostratigraphy, can be useful in demonstrating the occurrence of a substantial time gap across a suspected subaerial unconformity.

Barrell (1917) and Wheeler (1958) related the origin of a subaerial unconformity to the movement of base level, which is the conceptual surface of equilibrium between erosion and deposition. Deposition can potentially occur where base level occurs above the surface of the Earth and erosion will occur in areas where it lies below the Earth's surface. A subaerial unconformity is interpreted to form by subaerial erosional processes, especially those connected to fluvial and/or chemical erosion, during a time of base-level fall (Jervey, 1988). As base level falls beneath the Earth's surface, subaerial erosion cuts down to that level.

Wheeler (1958) and Jervey (1988) also

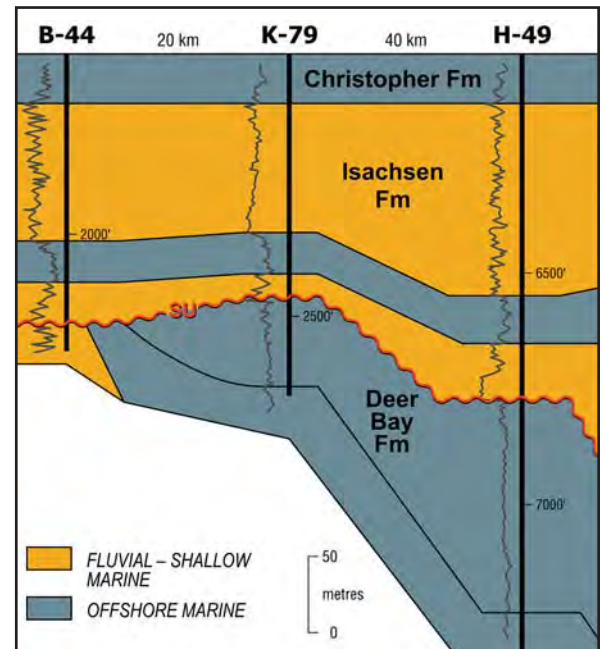

Figure 4.3. An SU is delineated on this cross section on the basis of the truncation of the underlying strata of the Deer Bay Formation and the occurrence of fluvial strata directly above the unconformity.

showed that a subaerial unconformity advances basinward during the entire time of base-level fall and reaches its maximum basinward extent at the end of base-level fall. It continues to form during subsequent base-level rise as it retreats landward and is overlain by nonmarine to brackish sediment.

In regards to its relation to time surfaces, a subaerial unconformity is commonly an approximate time barrier and time surfaces,

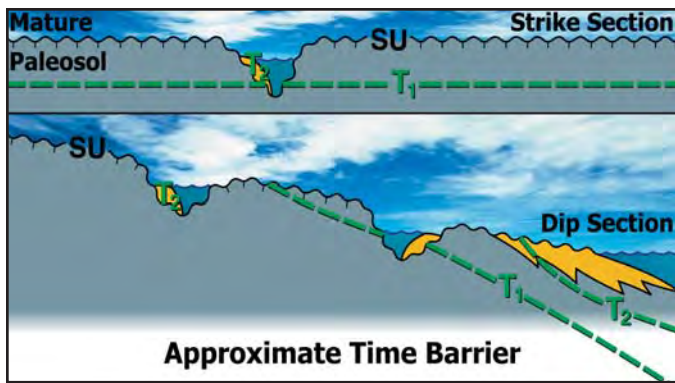

Figure 4.4. An SU is often an approximate time barrier because fluvial strata deposited during base-level fall can be preserved in incised valleys. Such strata (deposited at time T2) are the same age as deltaic strata deposited down dip and which underlie the SU. In this case some strata on top of the interpreted SU are older than some strata below it and it is not a perfect time barrier.

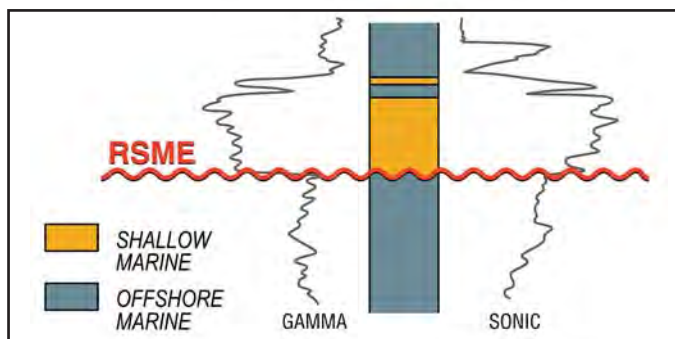

Figure 4.5. An RSME is interpreted at the base of the sandstone because it is an abrupt contact which is underlain by offshore shelf strata which coarsen-upward (see sonic log) and overlain by coarsening-upward shoreface strata (after Plint, 1988).

for the most part, do not pass through it. In other words, almost all strata below the surface are older than almost all those above.

There are definitely exceptions to this and these can be associated with migrating uplifts (Winker, 2002). Also, some fluvial strata, especially at the base of incised valley fills, may have been deposited during base-level fall (Suter et al, 1987; Galloway and Sylvia, 2002; Blum and Aslan, 2006) and are thus older than some of the down-dip strata below the unconformity (Figure 4.4). In this case, the actual subaerial unconformity would lie on top of fluvial strata deposited during fall. However, such a surface would likely be very hard to identify within a succession of fluvial strata and the basal contact of the fluvial strata is best interpreted as the SU unless compelling data dictate otherwise (Suter et al., 1987).

The time-barrier aspect of a subaerial unconformity makes it an important surface for correlation and for bounding genetic units. This surface has been given other names besides subaerial unconformity such as lowstand unconformity (Schlager, 1992), regressive surface of fluvial erosion (Plint and Nummedal, 2000), and fluvial entrenchment / incision surface (Galloway and Sylvia, 2002). However, the term subaerial unconformity has the widest acceptance and is the one I would recommend for this surface.

Regressive Surface of Marine Erosion (RSME)

The regressive surface of marine erosion was first empirically recognized and named by Plint (1988) mainly on the basis of studies on Cretaceous strata in Alberta. Its defining characteristics include being a sharp, scoured surface and having offshore marine strata (usually mid to outer shelf) that coarsen upwards below the surface and coarsening

and shallowing-upward shoreface strata above the surface (Figure 4.5). The underlying shelf strata are variably truncated and the overlying shoreface strata downlap onto the RSME. Sometimes a *Glossifungites* trace fossil assemblage is associated with the RSME (MacEachern et al., 1992). The surface occurs within an overall regressive succession but is considered a change in depositional trend from deposition to nondeposition and back to deposition.

Plint (1988) interpreted the RSME formed during a time of base-level fall when the inner part of the marine shelf in front of the steeper shoreface is sometimes eroded. This area of inner shelf erosion, which can be up to a few tens of kilometres wide, moves seaward during the entire interval of base-level fall and is progressively covered by prograding shoreface deposits (Figure 4.6). Thus the RSME can potentially be quite widespread both along strike and down dip. However, it should be noted that in many cases an RSME either has a patchy distribution or does not form at all due to variations in sea floor slope, sedimentation rate, and base-level fall rate (Naish and Kamp, 1997; Hampson, 2000; Bhattacharya and Willis, 2001).

In most cases, erosion beneath the RSME is minor and localized and thus it is almost always a diastem and not an unconformity (Galloway and Sylvia, 2002). Sometimes local truncation of strata beneath an RSME can be demonstrated but this requires very close control. However, the potential for more substantial erosion exists and, in a few examples, it has been shown to be an unconformity where it has eroded through a subaerial unconformity (Bradshaw and Nelson, 2004; Cantalamessa and Celma, 2004).

Because the regressive surface of marine erosion migrates basinward during the entire time of base-level fall, it is a highly diachronous surface and time lines pass through it (offset) at a high angle (Embry, 2002) (Figure 4.7). It is not an approximate time barrier like a subaerial

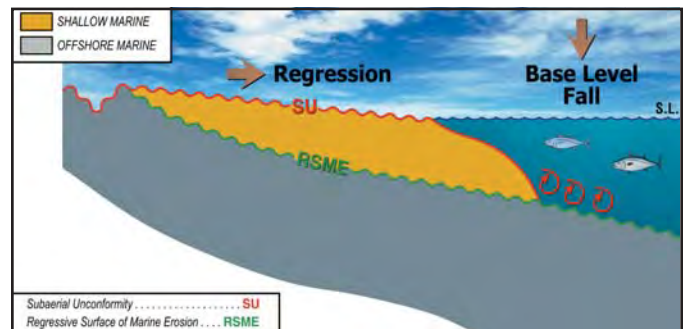

Figure 4.6. The RSME forms as a scour zone on the inner shelf in front of the shoreface during base-level fall. It migrates basinward during the entire interval of base-level fall and is downlapped by shoreface strata which are in turn capped by an SU.

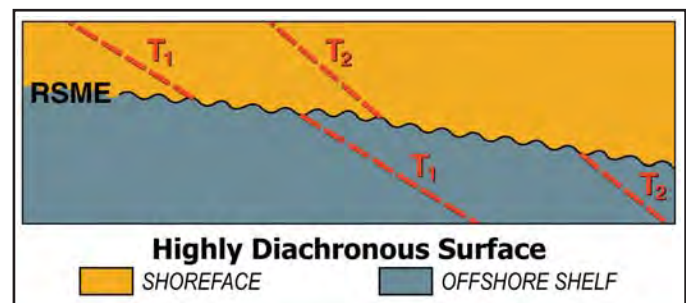

Figure 4.7. The RSME is a highly diachronous surface and time surfaces pass through it at a high angle. The time surfaces are offset across the RSME with shoreface strata above the RSME being the same age as offshore shelf strata below it. The RSME is not a time barrier.



unconformity except in the few instances where it has eroded through a subaerial unconformity (e.g., Cantalamessa and Celma, 2004). Because it is most often a highly diachronous, diastemic surface and has a very patchy distribution, the RSME is not suitable for use as a bounding surface for sequence stratigraphic units or for being part of a correlation framework. However, it is important to recognize such a surface when it is present and to use it as part of facies analysis inside the established sequence stratigraphic correlation framework. Galloway and Sylvia (2002) referred to this surface as the regressive ravinement surface. The term regressive surface of marine erosion is most commonly used and is recommended.

References

- Barrell, J. 1917. Rhythms and the measurements of geologic time. *Bulletin of the Geological Society of America*, v. 28, p. 745-904.
- Bhattacharya, J. and Willis, B. 2001. Lowstand deltas in the Frontier Formation, Powder River Basin, Wyoming: implications for sequence stratigraphic models. *American Association of Petroleum Geologists Bulletin*, v. 85, p. 261-294.
- Blum, M. and Aslan, A. 2006. Signatures of climate versus sea level change within incised valley fill successions: Quaternary examples for the Texas Gulf Coast. *Sedimentary Geology*, v. 190, p. 177-211.
- Bradshaw, B. and Nelson, C. 2004. Anatomy and origin of autochthonous late Pleistocene forced regressive deposits, east Coromandel inner shelf, New Zealand: implications for the development and definition of the regressive systems tract. *New Zealand Journal of geology and Geophysics*, v. 47, p. 81-97.
- Cantalamessa, G. and Di Celma, C. 2004. Sequence response to syndepositional regional uplift: insights from high-resolution sequence stratigraphy of late early Pleistocene strata, Periadriatic Basin, central Italy. *Sedimentary Geology*, v. 164, p. 283-309.
- Cartwright, J., Haddock, R., and Pinheiro, R. 1993. The lateral extent of sequence boundaries. In: Williams, G. and Dobb, A. (eds.) *Tectonics and sequence stratigraphy*. Geological Society London Special Publication 71, p. 15-34.
- Embry, A.F. 1995. Sequence boundaries and sequence hierarchies: problems and proposals. In: Steel, R.J., Felt, F.L., Johannessen, E.P. and Mathieu, C. (eds.) *Sequence stratigraphy on the northwest European margin*. Norwegian Petroleum Society (NPF) Special Publication 5, p. 1-11.
- Embry, A. 2001. The six surfaces of sequence stratigraphy. *American Association of Petroleum Geologists Hedberg Conference on sequence stratigraphic and allostratigraphic principles and concepts*, Dallas. Abstract volume, p. 26-27.
- Embry, A.F. 2002. Transgressive-Regressive (T-R) Sequence Stratigraphy. In: Armentrout, J and Rosen, N. (eds.). *Sequence stratigraphic models for exploration and production*. Society for Sedimentary Geology (SEPM), Gulf Coast SEPM Conference Proceedings, Houston, p. 151-172.
- Galloway, W.E. and Sylvia, D.A. 2002. The many faces of erosion: theory meets data in sequence stratigraphic analysis. In: Armentrout, J and Rosen, N. (eds.). *Sequence stratigraphic models for exploration and production*. Society for Sedimentary Geology (SEPM), Gulf Coast SEPM Conference Proceedings, Houston, p. 99-111.
- Hampson, G. 2000. Discontinuity surfaces, clinofolds and facies architecture in a wave dominated, shoreface-shelf parasequence. *Journal of Sedimentary Research*, v. 70, p. 325-340.
- Janson, X, Eberli, G., Bonnaffé, F., Gaumet, F., and de Casanove, V. 2007. Seismic expression of a prograding carbonate margin, Mut Basin, Turkey. *American Association of Petroleum Geologists Bulletin*, v. 91. p. 685-713.
- Jervey, M. 1988. Quantitative geological modeling of siliciclastic rock sequences and their seismic expression. In: Wilgus, C., Hastings, B.S., Kendall, C.G., Posamentier, H.W., Ross, C.A., and Van Wagoner, J.C. (eds.). *Sea level changes: an integrated approach*. Society for Sedimentary Geology (SEPM) Special Publication 42, p.47-69.
- Maceachern, J., Raychaudhuri, I., and Pemberton, G. 1992. Stratigraphic applications of the Glossifungites ichnofacies delineating discontinuities in the rock record. In: Pemberton, G. (ed.), *Applications of Ichnology to Petroleum Exploration*. Society for Sedimentary Geology (SEPM) Core Workshop Notes 17, p. 169-198.
- Naish, T. and Kamp, P. 1997. Sequence stratigraphy of 6th order (41 k.y.) Pliocene – Pleistocene cyclothems, Wanganui Basin, New Zealand: a case for the regressive systems tract. *Geological Society of America Bulletin*, v. 109, p. 979-999.
- Plint, A. 1988. Sharp-based shoreface sequences and offshore bars in the Cardium Formation of Alberta: their relationship to relative changes in sea level. In: Wilgus, C., Hastings, B.S., Kendall, C.G., Posamentier, H.W., Ross, C.A., and Van Wagoner, J.C. (eds.). *Sea level changes: an integrated approach*. Society for Sedimentary Geology (SEPM) Special Publication 42, p. 357-370.
- Plint, A. and Nummedal, D. 2000. The falling stage systems tract: recognition and importance in sequence stratigraphic analysis. In: Hunt, D. and Gawthorpe, R. (eds.). *Sedimentary responses to forced regressions*. Geological Society of London, Special Publication 172, p. 1-17.
- Schlager, W. 1992. *Sedimentology and sequence stratigraphy of reefs and carbonate platforms*. American Association of Petroleum Geologists Continuing Education Course Notes Series # 34. 71 p.
- Schlager, W. 2005. *Carbonate sedimentology and sequence stratigraphy*. Society for Sedimentary Geology (SEPM) Concepts in Sedimentology and Paleontology 8, 200 p.



Practical Sequence Stratigraphy V

The Material-based Surfaces of Sequence Stratigraphy, Part 2: Shoreline Ravinement and Maximum Regressive Surface

by Ashton Embry

Introduction

As discussed in the last installment of this series, six material-based surfaces of sequence stratigraphy have been empirically recognized over the past 200 years. Each surface represents a specific change in depositional trend which can be recognized on the basis of observational data. Collectively, these surfaces are the basic building blocks of sequence stratigraphy and allow high resolution correlations, definition and delineation of specific sequence stratigraphic units, and interpretations of depositional history in terms of base-level change. The two surfaces discussed in my last article, the subaerial unconformity and the regressive surface of marine erosion, formed primarily during base-level fall. The two surfaces which are discussed in this article, shoreline ravinement and maximum regressive surface, form at the start of, and during, base-level rise.

As will be discussed, both these surfaces potentially have great utility in sequence stratigraphic analyses. Furthermore, as material-based surfaces, they can be identified on the basis of physical characteristics which include the nature of the surface itself, the nature of underlying and overlying strata, and the geometrical relationships between the surface and surfaces in underlying and overlying strata. The relationship of the surfaces to either base-level change or to a change in shoreline direction has no role in their definition and characterization. However, the origin of each surface is interpreted in terms of the interaction of sedimentation with base-level change.

Shoreline Ravinement (SR)

A stratigraphic surface referred to herein as a shoreline ravinement has been empirically recognized for a long time. Excellent descriptions of the surface and its mode of origin were given by Stamp (1921), Bruun (1962), and Swift (1975). The characteristic attributes of a shoreline ravinement which allow its recognition are an abrupt, scoured contact overlain by estuarine or marine strata which fine and deepen upwards. Underlying strata can vary from non-marine

to fully marine. As a scoured contact, it represents a change in trend from deposition to non-deposition and, as will be discussed in more detail, it can vary along its extent from being a minor diastem to being a major unconformity.

The origin of a shoreline ravinement surface was determined by early workers on the basis of observations along modern shorelines which are transgressing (i.e., moving landward). Because the slope of the alluvial plain is commonly less than that of the shoreface, erosion carves out a new shoreface profile as the shoreline moves landward during transgression. One or more such erosional surfaces form as wave and/or tidal processes erode previously deposited shoreface, beach, brackish, and non-marine sediment. The eroded sediment is deposited both landward and seaward of the shoreline (Figure 5.1). When both tidal and wave processes are acting in a given area, both a tidal shoreline ravinement and a wave shoreline ravinement can form (Dalrymple et al., 1994; Zaitlin et al., 1994), although in most cases only a wave shoreline ravinement is preserved.

The SR begins to form at the start of transgression which occurs when rate of

base-level rise exceeds the sedimentation rate at the shoreline. This often occurs very soon after the start of base-level rise along most of the shoreline where the sedimentation rate is low to moderate (Embry, 2002). The SR stops being generated at the end of transgression which can occur at anytime during base-level rise depending on the interaction of the rate of base-level rise with the rate of sediment supply. Because it develops over the entire time of transgression, a shoreline ravinement is often considered to be diachronous (e.g., Nummedal et al., 1993). However, over its extent, it can either be a diastem or an unconformity and thus can exhibit two different relationships with regards to time (Figure 5.2, page 18). It is important to determine which parts of a given shoreline ravinement are unconformable (unconformable shoreline ravinement, SR-U) and which parts are diastemic (diastemic shoreline ravinement, SR-D).

A diastemic portion of a shoreline ravinement (SR-D) has the defining characteristics of an SR as described above and is further characterized by the presence of penecontemporaneous, nonmarine strata underlying the surface and the preservation of the previously developed subaerial

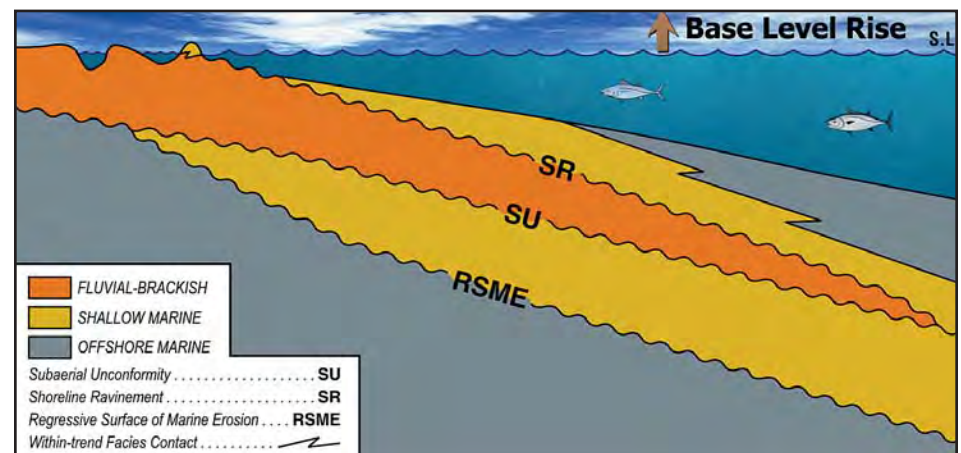

Figure 5.1. The shoreline ravinement (SR) forms by shoreface erosion during transgression. It migrates landward during the entire interval of transgression and thus can form a widespread surface. In this example the shoreline ravinement surface has cut down only partially through the succession of non-marine/brackish strata that were deposited contemporaneously with the formation of the SR. In this case the SR is a highly diachronous diastem.



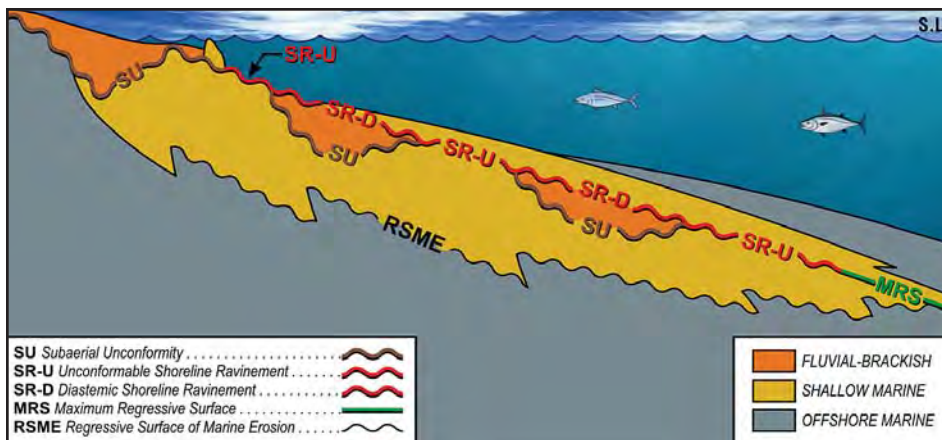

Figure 5.2. The two different time relationships of a shoreline ravinement surface. A shoreline ravinement surface is a highly diachronous diastem (SR-D) when it has not eroded the underlying subaerial unconformity. However, when it has eroded the underlying subaerial unconformity (SU), it is an unconformity and a time barrier (SR-U) with all strata below being older than all strata above the surface.



Figure 5.3. In this outcrop of Early Cretaceous strata from eastern Axel Heiberg Island, a subaerial unconformity (SU) is present beneath the white-weathering fluvial sandstone. A shoreline ravinement occurs at a scoured contact which occurs at the base of a thin, marine sandstone which fines upward into marine shale and siltstone of mid-shelf origin. The strata between the SU and the SR are fluvial in origin. In this case the SR is a diastemic shoreline ravinement (SR-D) which is highly diachronous.

unconformity (Figures 5.1, page 17; 5.2; 5.3; 5.4). At any given locality, there is only a very minor time gap across a diastemic shoreline ravinement and overall it is a highly diachronous surface with time lines cutting it at a high angle and somewhat offset (Figure 5.5).

In contrast, a portion of a shoreline ravinement that has removed both the penecontemporaneous, non-marine strata that were deposited behind the shoreface as it moved landward, and the subaerial unconformity that had formed during the preceding base-level fall and regression

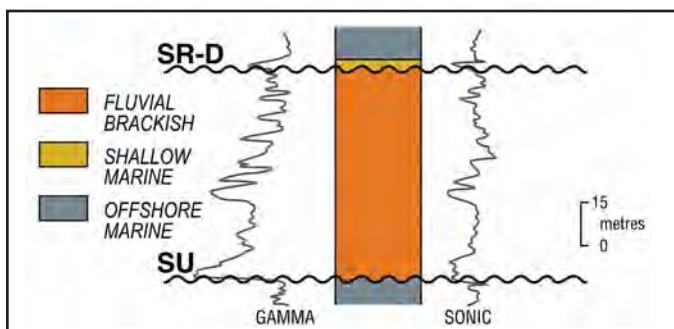

Figure 5.4. A subsurface section of Early Cretaceous strata with accompanying gamma ray/sonic logs. A shoreline ravinement separates non-marine strata below from marine strata above. The subaerial unconformity which formed during the preceding base-level fall is preserved and the SR is a highly diachronous, diastemic shoreline ravinement (SR-D).

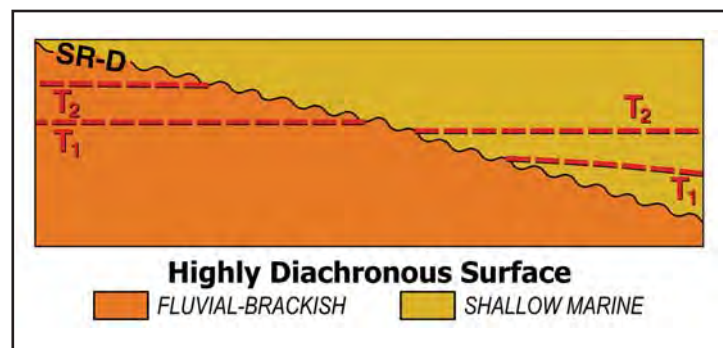

Figure 5.5. The time relationships of a diastemic shoreline ravinement (SR-D) which overlies penecontemporaneous fluvial-brackish strata. Time surfaces cut the SR-D at a high angle and are offset across the surface. Thus the SR-D is a highly diachronous surface.

(Figure 5.2), is an unconformity and not a diastem. With the removal of the subaerial unconformity, the shoreline ravinement takes on the time relationships of the subaerial unconformity and becomes a time barrier that represents a significant gap in the stratigraphic record. All strata below an unconformable shoreline ravinement are older than all strata on top of it (Figure 5.6).

The SR-U has the defining characteristics of an SR and an additional characteristic is that, in most cases, the underlying strata are marine rather than non-marine (Figures 5.7, 5.8). However, the key characteristic which allows the confident recognition of an SR-U is that the strata below are regionally truncated and the marine strata above often onlap (Figure 5.9, page 18). Such relationships are often clearly imaged on seismic data (Suter et al., 1987) or are determined by correlations on well log and outcrop cross sections. Notably the SR-U illustrated on the log of Figure 5.8 would be hard to identify if it could not be demonstrated that truncation was occurring at the stratigraphic level.

Many major unconformities in the stratigraphic record, including some of those used by Sloss (1963) to define his continent-wide sequences, are unconformable shoreline ravinements rather than subaerial unconformities (e.g., the major, base Norian unconformity illustrated in Figure 5.9, page 18). An unconformable shoreline ravinement can be differentiated from a subaerial unconformity by the presence of marine strata directly above the surface. This characteristic contrasts with that of an SU which has fluvial/brackish strata directly overlying the surface. When estuarine deposits directly overlie an unconformity, it is sometimes difficult to decide if the SU has been preserved or has been eroded by estuarine (tidal?) currents (i.e., surface is an SR-U).

In carbonate rocks, a subaerial unconformity

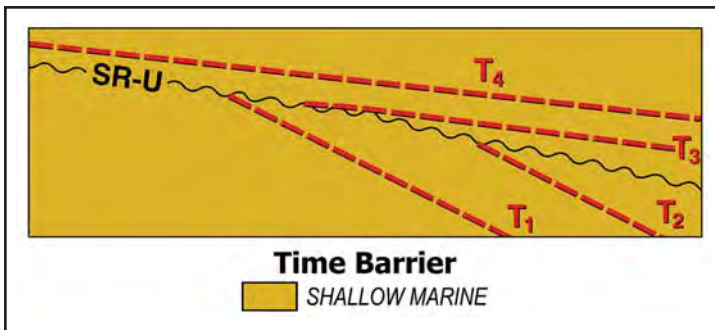

Figure 5.6. The time relationships of an unconformable shoreline ravinement (SR-U) which has completely eroded the pencontemporaneous fluvial-brackish strata as well as the subaerial unconformity. Time lines are truncated below the SR-U and onlap the SR-U. All strata below the SR-U are entirely older than all strata above it, making an unconformable shoreline ravinement a time barrier.



Figure 5.7. In this outcrop of Triassic strata from northern Ellesmere Island, an unconformable shoreline ravinement (SR-U) occurs at the base of a thin, marine shelf limestone unit (3m) which overlies marine siltstones of mid-shelf origin. The key characteristics of an SR illustrated here are the sharp, scoured contact and the deepening-upward, marine succession directly overlying the SR. Importantly, regional correlations indicate that about 400 metres of strata are missing beneath the SR-U at this locality.

which develops during an episode of base-level fall is not often preserved, in part because little sediment is deposited above high tide. The shoreline ravinement which develops during the following transgression usually removes any thin veneer of supratidal sediment and erodes the subaerial unconformity such that marine strata occur on both sides of the surface. Admittedly, because carbonate strata tend to be cemented very early, especially in situations of exposure, such shoreline erosion during transgression may be extremely minor. However, for consistency and clarity, I suggest use of the term unconformable shoreline ravinement rather than subaerial unconformity in situations where marine carbonate strata directly overlie such an unconformable surface.

In terms of utility, the unconformable portion of an SR (SR-U) is very useful for correlation and for bounding sequence stratigraphic units because it is a time barrier. However, the diastemic portion of an SR (SR-D) is not useful for these purposes because of its highly diachronous nature. Like the RSME, the SR-D is correlated to delineate separate facies units within a sequence stratigraphic framework.

This distinctive surface has been given a variety of names including ravinement surface (Swift, 1975), transgressive ravinement surface (Galloway and Sylvania, 2002), transgressive surface (Van Wagoner et al., 1988), transgressive surface of erosion (Posamentier and Allen, 1999), and shoreface ravinement (Embry, 2002). I prefer to use the term shoreline ravinement for this very distinctive surface with the proviso that modifiers such as tidal and wave can be added to it. I would emphasize it is important to add the modifier diastemic or unconformable to any stretch of shoreline ravinement surface to differentiate between the two very different relationships to time (highly diachronous or time barrier) that exist for a given shoreline ravinement (Figure 5.2).

Maximum Regressive Surface (MRS)

The maximum regressive surface has been recognized from empirical data for as long as fining/coarsening and deepening/shallowing cycles ("transgressive-regressive or T-R cycles") have been recorded in the stratigraphic record (at least 150 years). The main characteristic for identification of an MRS in marine clastic strata is it is a conformable horizon or diastemic surface which marks a change in trend from coarsening-upward to fining-upward. The MRS is never an unconformity. Over most of its extent, the MRS also coincides with a change from shallowing-upwards to deepening-upward and this criterion is very helpful, especially in shallow water facies (Figure 5.10, page 18). In deeper water, high subsidence areas, the change from shallowing to deepening may not coincide with the MRS as defined by grain size criteria (Vecsei and Düringer, 2003)

In nonmarine siliciclastic strata, the change from coarsening to fining is also applicable for objectively identifying an MRS. In carbonate strata the change from shallowing upward to deepening upward is usually the most reliable and readily applicable criterion for identifying an MRS. The change in trend from coarsening to fining also is applicable for carbonates but sometimes can be misleading.

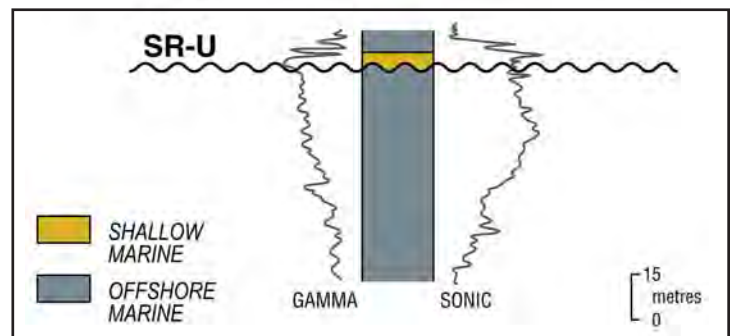

Figure 5.8. The subsurface succession of Jurassic marine strata from the Melville Island area illustrated here contains a major unconformity as determined from seismic data and regional correlations. The unconformity is an unconformable shoreline ravinement (SR-U) which occurs at the base of a thin, fining-upward marine sandstone interval. The key characteristics which lead to this interpretation include, a sharp contact, marine strata which fine and deepen-upward directly overlying the surface, marine strata below the surface, and regional truncation below the surface.



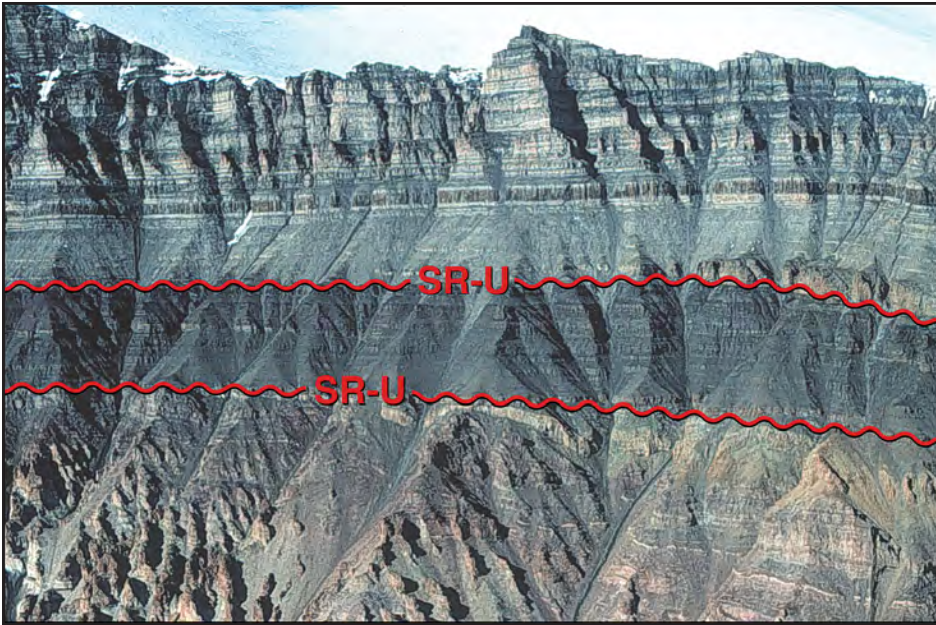

Figure 5.9. This outcrop of Carboniferous and Late Triassic strata on northeastern Ellesmere Island contains two major unconformities, both of which are unconformable shoreline ravinements (SR-U). The lower one places Norian strata on tilted Carboniferous strata (time gap of about 90 MA). A thin unit of shallow marine sandstone which fines and deepens upward directly overlies the unconformity leaving no doubt that it is an SR-U rather than an SU. The upper unconformity is at the base of Rhaetian strata (Late Triassic) and, on the right side, a marine sandstone can be seen onlapping the SR-U towards the left. Regional correlations indicate substantial truncation of Norian strata beneath the unconformable shoreline ravinement (SR-U) at the base of the Rhaetian.



Figure 5.10. In the outcropping succession of Early and Middle Triassic strata on northern Ellesmere Island, a maximum regressive surface (MRS) has been delineated near the top of a white-weathering, shoreface sandstone unit. Beneath the MRS, the strata coarsen- and shallow-upward. On top of the MRS, the strata fine- and deepen-upward. At this locality, the MRS is a conformable horizon.

For larger magnitude MRSs which separate successions that contain smaller scale, sequence stratigraphic units, such coarsening and fining trends are sometimes recorded by stacking patterns of the smaller scale units (Van Wagoner et al., 1990). For example, in a stacking pattern which represents a coarsening trend, each small scale unit contains a greater proportion of coarser material than the underlying one. Thus an MRS separates an overall coarsening-upward stacking pattern (often referred to as progradational) from a fining-upward stacking pattern (often referred to as retrogradational).

The recognition of an MRS depends on the availability of data which reflects the grain size of the sediment (with or without small scale units) and from which general water depths of the deposits can be interpreted from facies analysis. The MRS may occur within a gradational interval of facies change (conformable horizon) or it can be rather abrupt with a scour surface marking it (diastem). On a gamma log of siliciclastic sediments, the MRS in marine strata often, but certainly not always, marks the inflection point from decreasing gamma ray (gradual shift to the left) (coarsening-upward and decreasing clay) to increasing gamma ray (a shift to the right) (fining-upward and increasing clay) (Figure 5.11). In pure carbonate systems, gamma logs are of no help for MRS identification and facies data from core and/or cuttings are required.

It must be noted that the MRS is laterally equivalent to the shoreline ravinement (Figure 5.12) and this relationship results from the fact that both surfaces begin to be generated at the start of transgression (see below). Furthermore it may be difficult to distinguish an MRS from an unconformable shoreline ravinement (SR-U) because both can separate coarsening-upward marine strata below from fining upward marine strata above and both can be scoured contacts. For example an MRS might have been interpreted in the succession illustrated on Figure 5.8 (page 17) at the top of the thin, transgressive sandstone which overlies the SR-U.

The key criterion for distinguishing these two different surfaces is that an SR-U is an unconformity with truncation below and onlap above whereas the MRS is either a conformity or diastem which is not associated with truncation or onlap. Thus regional data in the form of cross-sections and/or seismic data are usually required when uncertainty exists.

Given the coincidence of the start of fining and the start of deepening in shallow facies at the MRS, it is reasonable to interpret that

an MRS is generated at or close to the start of transgression. Transgression begins when the rate of base-level rise exceeds the rate of sediment supply at the shoreline. Finer grained sediment is then deposited at any given locality along an offshore transect and the MRS is marked by the change from coarsening upward to fining upward.

Given that the rate of sediment supply along a siliciclastic shoreline will substantially vary, the start of transgression occurs at different times but, in most cases, transgression will be initiated along the entire shoreline within a relatively short time interval. Furthermore, this time interval of MRS generation occurs from the start of base-level rise (areas of moderate to no sediment input) to soon after the start of base-level rise (areas of higher sediment input). Thus the MRS will be somewhat diachronous but such diachroneity will be minor (Figure 5.13). Empirical data from carbonate strata indicate the same relationships of the MRS to time. Theoretically there may be exceptions to this generality but they have not been documented.

This surface has been called a variety of names including transgressive surface (Van Wagoner et al., 1988), conformable transgressive surface (Embry, 1993, 1995), maximum progradation surface (Emery and Myers, 1996), and sometimes by the more general term, flooding surface. The more descriptive and less ambiguous term, maximum regressive surface, which was introduced by Helland-Hansen and Gjølberg (1994), is recommended when referring to this surface.

The low diachroneity of the MRS as well as its ready identification in outcrop, on logs (siliciclastic), and on seismic sections make the MRS a very useful surface for correlation and contributing to a regional, quasi-time framework as well as for bounding sequence-stratigraphic units.

References

Bruun, P. 1962. Sea-level rise as a cause of shore erosion. *American Society of Civil Engineers Proceedings, Journal of the Waterways and Harbors Division*, v. 88, p. 117-130.

Dalrymple, R., Zaitlin, B., and Boyd, R. (eds.). 1994. *Incised valley Systems: Origin and sedimentary sequences*. SEPM, Special Publication 51, 391 p.

Embry, A.F. 1993. Transgressive-regressive (T-R) sequence analysis of the Jurassic succession of the Sverdrup Basin, Canadian Arctic Archipelago. *Canadian Journal of Earth Sciences*, v. 30, p. 301-320.

Embry, A.F. 1995. *Sequence boundaries and*

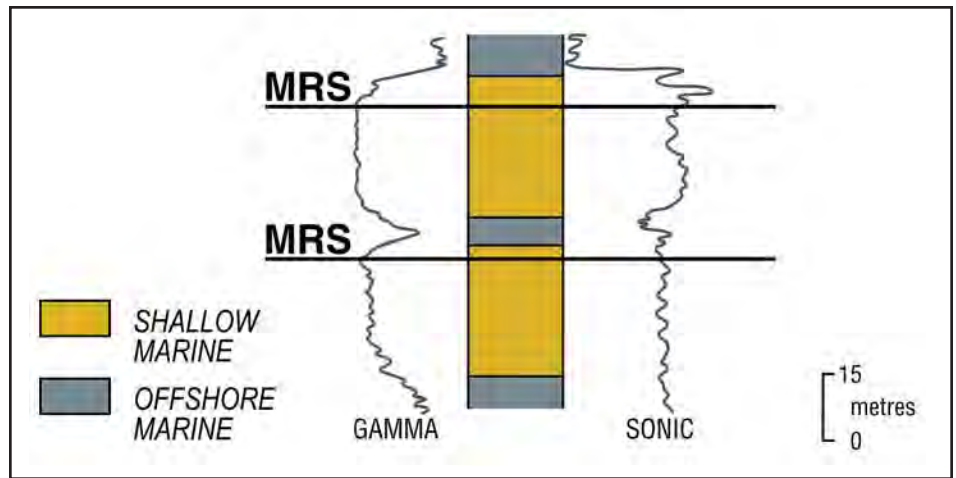

Figure 5.11. Two maximum regressive surfaces (MRS) have been delineated in this subsurface succession of Jurassic strata from the Loughheed Island area. The MRSs have been placed at the change in gamma log trend from decreasing gamma ray to increasing gamma ray. This change in gamma ray trend is interpreted to reflect a change from shallowing-upward (decreasing clay content) to deepening-upward (increasing clay content).

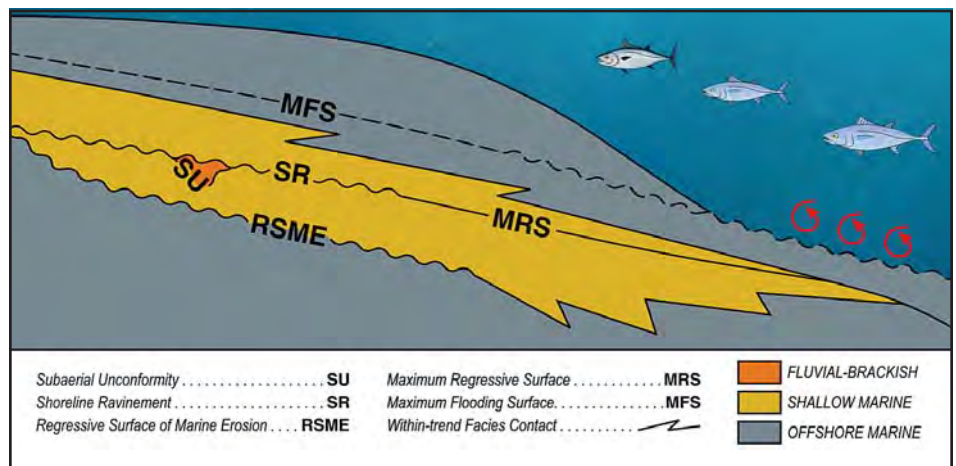

Figure 5.12. A schematic diagram showing the interpreted relationship between an MRS and other surfaces of sequence stratigraphy. The landward termination of the maximum regressive surface (MRS) adjoins the basinward termination of the shoreline ravinement (SR). This relationship occurs because both surfaces begin to form at the start of transgression and is an important one in terms of selecting boundaries for sequence stratigraphic units.

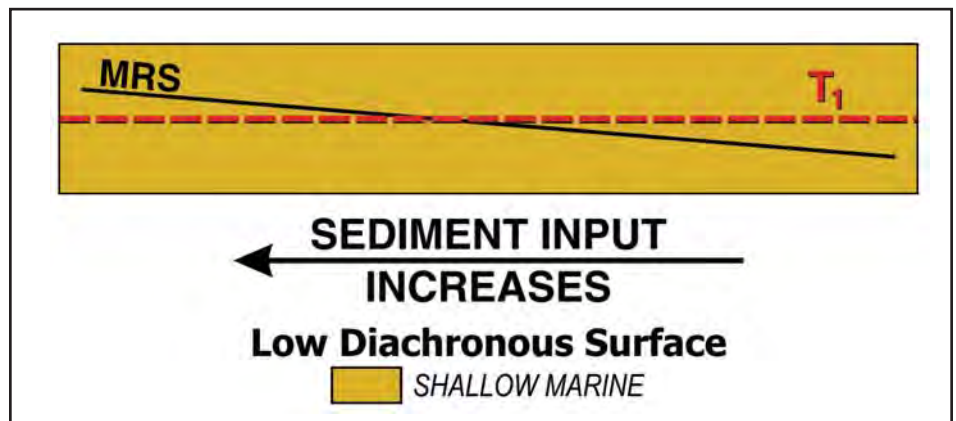

Figure 5.13. The relationship of the maximum regressive surface (MRS) to time. The MRS will approximate a time surface perpendicular to the shoreline but will exhibit minor diachroneity along strike due to varying rates of sediment input along the shoreline.



sequence hierarchies: problems and proposals, In: Steel, R.J., Felt, F.L., Johannessen, E.P., and Mathieu, C. (eds). *Sequence stratigraphy on the northwest European margin: NPF Special Publication 5*, p. 1-11.

Embry, A.F. 2002. *Transgressive-Regressive (TR) Sequence Stratigraphy*, in Armentrout, J. and Rosen, N. (eds.). *Sequence stratigraphic models for exploration and production: Gulf Coast SEPM Conference Proceedings, Houston*, p. 151-172.

Emery, D. and Myers, K. 1997. *Sequence Stratigraphy*. Blackwell, London, 297 p.

Galloway, W.E. and Sylvia, D.A. 2002. *The many faces of erosion: theory meets data in sequence stratigraphic analysis*, in Armentrout, J. and Rosen, N. (eds.). *Sequence stratigraphic models for exploration and production: Gulf Coast SEPM Conference Proceedings, Houston*, p. 99-111.

Helland-Hansen, W. and Gjelberg, J. 1994. *Conceptual basis and variability in sequence stratigraphy: a different perspective*. *Sedimentary Geology*, v. 92, p. 1-52.

Nummedal, D., Riley, G., and Templet, P. 1993. *High resolution sequence architecture: a chronostratigraphic model based on equilibrium profile studies*. In: Posamentier, H., Summerhayes, C., Haq, B., and Allen, G. (eds.). *Sequence stratigraphy and facies association. International Association of Sedimentologists, Special Publication 18*, p. 55 – 68.

Posamentier, H. and Allen, G. 1999. *Siliciclastic sequence stratigraphy – concepts and applications*. *SEPM Concepts in Sedimentology and Paleontology*, no. 7, 210 p.

Sloss, L. 1963. *Sequences in the cratonic interior of North America*. *GSA Bulletin*, v. 74, p. 93-113.

Stamp, L. 1921. *On cycles of sedimentation in the Eocene strata of the Anglo-Franco-Belgian Basin*. *Geological Magazine*, v. 58, p. 108-114.

Suter, J., Berryhill, H., and Penland, S. 1987. *Late Quaternary sea level fluctuations and depositional sequences, southwest Louisiana continental shelf*. In: Nummedal, D., Pilkey, O., and Howard, J. (eds.). *Sea-level changes and coastal evolution: SEPM Special Publication 41*, p. 199-222.

Swift, D. 1975. *Barrier island genesis: evidence from the central Atlantic shelf, eastern USA*. *Sedimentary Geology*. 14, p. 1-43.

Van Wagoner, J.C., Posamentier, H.W., Mitchum, R.M., Vail, P.R., Sarg, J.F., Loutit, T.S., and Hardenbol, J. 1988. *An overview of the fundamentals of sequence stratigraphy and key definitions*, In: Wilgus, C., Hastings, B.S., Kendall, C.G., Posamentier, H.W., Ross, C.A., and Van Wagoner, J.C. (eds.). *Sea level changes: an integrated*

approach: SEPM Special Publication 42, p. 39-46.

Van Wagoner, J.C., Mitchum, R.M., Campion, K.M., and Rahmanian, V.D. 1990. *Siliciclastic sequence stratigraphy in well logs, cores and outcrops: AAPG Methods in Exploration*, no. 7, 55 p.

Vecsei, A. and Düringer, P. 2003. *Sequence stratigraphy of Middle Triassic carbonates and terrigenous deposits (Muschelkalk and lower Keuper) in the SW Germanic Basin: maximum flooding versus maximum depth in intracratonic basins*. *Sedimentary Geology*, v. 160, p. 81-105.

Zaitlin, B., Dalrymple, R., and Boyd, R. 1994. *The stratigraphic organization of incised-valleys systems associated with relative sea level change*. In Dalrymple, R. and Zaitlin, B. (eds.). *Incised valley systems: origin and sedimentary sequences: SEPM special publication 51*, p. 45-60.



Practical Sequence Stratigraphy VI

The Material-based Surfaces of Sequence Stratigraphy, Part 3: Maximum Flooding Surface and Slope Onlap Surface

by Ashton Embry

Introduction

Four material-based surfaces of sequence stratigraphy – subaerial unconformity, regressive surface of marine erosion, shoreline ravinement, and maximum regressive surface, were described in the previous two articles in this series. In this installment, the final two material-based surfaces – maximum flooding surface and slope onlap surface – are described and discussed. Like the other material-based surfaces, each of these surfaces has a unique combination of physical characteristics which allow it to be defined and delineated in a variety of stratigraphic settings and with various types of data.

The origin of these surfaces, like those previously described, can be explained by the interaction of sedimentation and base-level change. And, also like the other surfaces, these have substantial utility for contributing to an approximate time correlation framework and for acting as boundaries for specific sequence stratigraphic units.

Maximum Flooding Surface (MFS)

The maximum flooding surface has been recognized on the basis of empirical data for over a century, although the specific name maximum flooding surface has been applied to it for only the past 20 years. Its value for correlating well log sections was recognized by the 1950s and many so-called “markers” on published cross-sections would be now designated as maximum flooding surfaces (e.g., Forgotson, 1957; Oliver and Cowper, 1963). Frazier (1974) called such a surface a “hiatal surface” and Vail et al. (1977) called the seismic reflector which encompassed this surface a downlap surface.

In marine siliciclastic strata, the MFS marks the change in trend from a fining upward trend below to a coarsening upward trend above (Embry, 2001) (Figure 6.1). In nearshore areas, this change in trend coincides with a change from deepening to shallowing. Farther offshore, this relationship does not hold and the deepest water horizon sometimes can lie above the MFS. In terms of stacking pattern, the MFS is

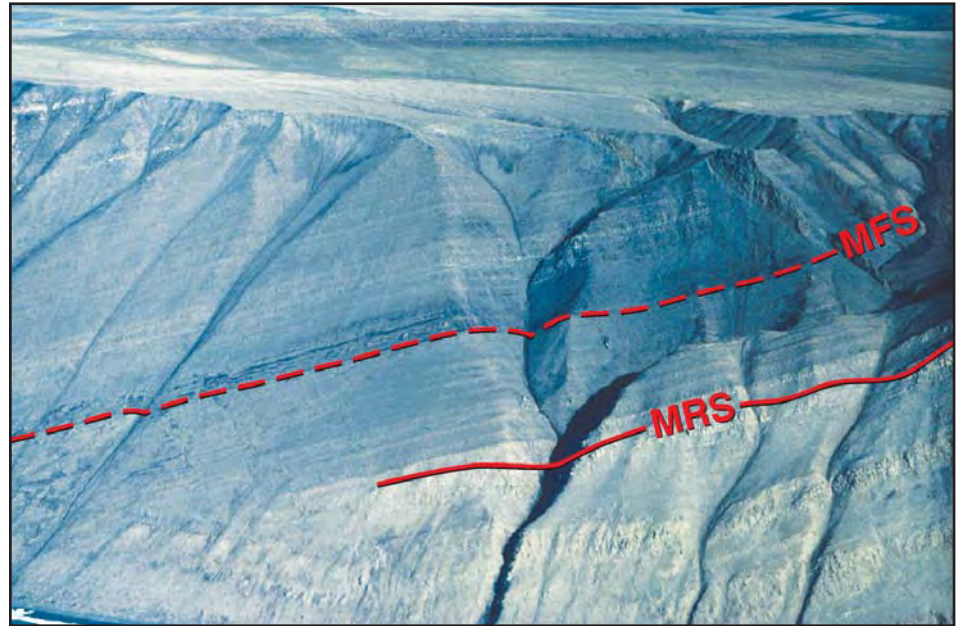

Figure 6.1. A surface section of Lower Triassic strata along the northeastern coast of Ellesmere Island, about 10 km north of the entrance to Hare Fiord. A maximum regressive surface (MRS) has been delineated high in a succession of shelf sandstones that coarsen and shallow upwards. The strata above the MRS fine and deepen upward to a thin, fossil-rich, limestone bed, the top of which is delineated as a maximum flooding surface (MFS). Above the MFS, the strata coarsen upwards as shown by the increasingly lighter colour of the section.

underlain by a retrogradational pattern which displays an overall fining upward and is overlain by a prograding one which records an overall coarsening upward (see Van Wagoner et al., 1990).

In nonmarine, siliciclastic strata, the expression of the MFS can be more subtle, but once again the surface is best placed at the change in trend from a fining upward to a coarsening upward. In general, such a placement coincides with the change from decreasing fluvial channel content to one of increasing channel content (Cross and Lessenger, 1998). The MFS in nonmarine strata is sometimes associated with an absence of clastic material, which can coincide with a prominent coal bed (Hamilton and Tadros, 1994; Allen et al., 1996) or even a nonmarine to brackish water limestone.

In carbonate strata, the MFS also marks a change in trend from fining to coarsening. Notably, in a shallow-water carbonate-bank

setting, the MFS will mark the horizon of change between deepening upward to shallowing upward and this criterion, which employs facies analysis, can often be more reliable than grain-size variation for its delineation in such a setting. In deeper water, carbonate ramp settings, the MFS marks a change from decreasing and / or finer carbonate material to increasing and / or coarser carbonate material. In platform settings the MFS is most easily identified on the basis of the change from deepening to shallowing whereas on the adjacent slope and basin areas the grain-size criterion is more reliable.

Similar to identifying an MRS, the recognition of an MFS usually requires the availability of data which reflect the grain size of the sediment and from which general water depths of the deposits can be interpreted from facies analysis. On the basin flanks, the surface is either a minor scour surface (diastem) or conformity. In offshore areas it



can be an unconformity that developed mainly due to starvation and minor scouring in both carbonate and clastic regimes. Notably such an unconformity usually is not associated with any demonstrable truncation of strata but rather marks a major loss of time as evidenced by paleontological data. In offshore areas, the MFS often occurs within condensed strata which contain numerous diastems and, in siliciclastics, may be associated with a chemical deposit such as a limestone or ironstone (Figure 6.2).

On a gamma log of siliciclastic sediments, the MFS is best placed, in the absence of more precise data (e.g., core), at the inflection point from increasing gamma ray (gradual shift to the right indicating fining-upward and increasing clay) to decreasing gamma ray (a shift to the left indicating coarsening-upward and decreasing clay) (Figure 6.3). Where the MFS is represented by a chemical deposit such as an ironstone or limestone bed or concentration of glauconite, the log

expression of such lithologies can be variable (Loutit et al., 1988). In pure carbonate strata, it is not possible to use log response to recognize an MFS, and facies data from core are mandatory. On seismic data the MFS is represented by a reflector often referred to as a “downlap surface.” On cross-sections, higher order MFSs often appear to downlap onto a lower order MFS (e.g., Plint et al., 2001).

Given the physical characteristics of the MFS, it has been interpreted to be generated at a given locality mainly by a change from decreasing sediment supply to increasing sediment supply at that locality. Such a change in supply rate is most often associated with the change from transgression to regression. Regression begins when the rate of sediment supply starts to exceed the rate of base-level rise at the shoreline and the shoreline subsequently moves seaward. Coarser grained sediment is then deposited at any given locality along an offshore transect and

the MFS is marked by the change from fining-upward to coarsening-upward (Figure 6.4). Thus, the MFS is interpreted to be generated very near the time of start of regression.

On a regional scale, the start of regression will occur at slightly different times along the shoreline, and the MFS is generated later in areas of lower sediment supply (Figure 6.5). For example, the MFS of the last interglacial has already formed in high-input areas of the Gulf of Mexico but has yet to be generated in low-sediment-input areas away from the major rivers (Boyd et al., 1989). In most situations, an MFS is a low diachroneity surface with maximum diachroneity being parallel to depositional strike. Where the MFS is an unconformity, it is an approximate time barrier.

This surface has been called a hiatal surface (Frazier, 1974), a downlap surface (Vail et al., 1977; Van Wagoner et al., 1988), maximum transgressive surface (Helland- Hansen and

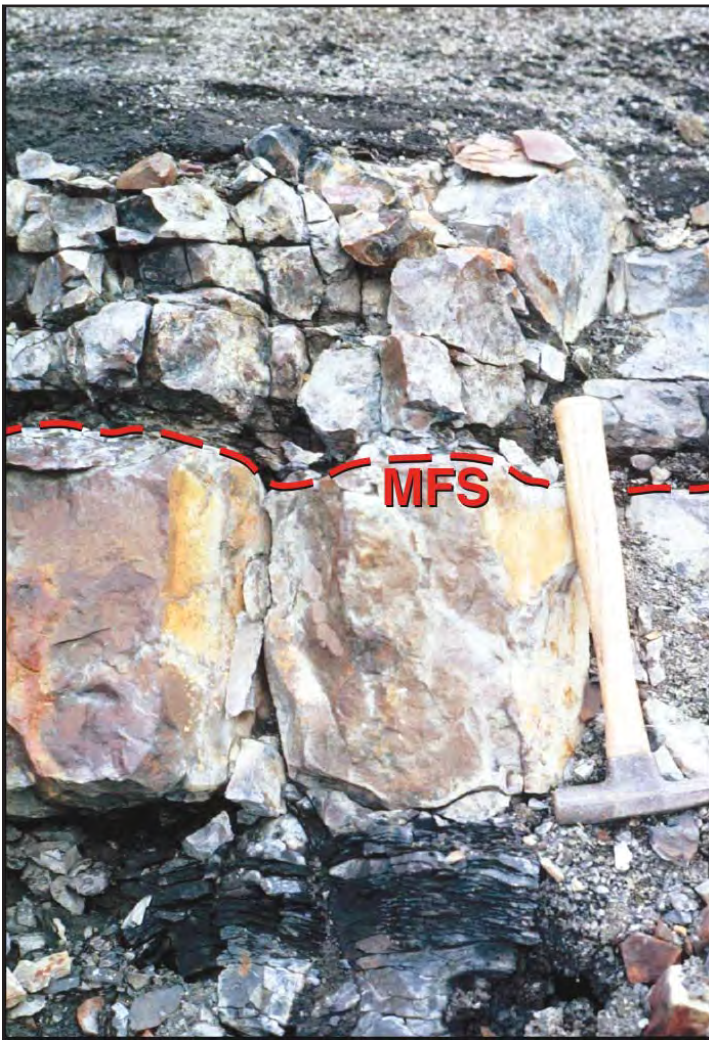

Figure 6.2. In this outcrop of Middle Jurassic strata from central Axel Heiberg Island, a maximum flooding surface (MFS) is placed at the top of an ironstone bed. Note that ironstone content increases upward in the shale below the ironstone bed and that argillaceous ironstone overlies the MFS. The MFS is drawn at the horizon with least clay influx.

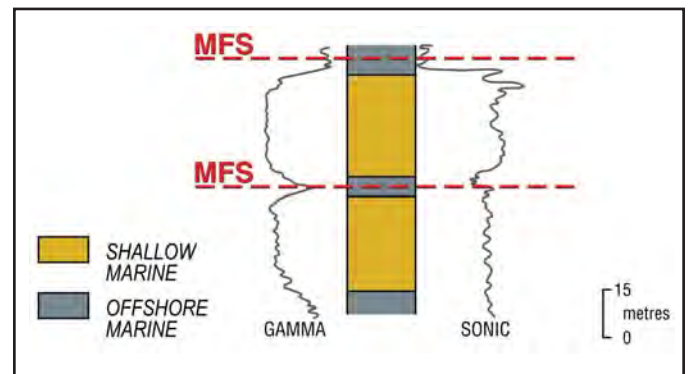

Figure 6.3. Two maximum flooding surfaces (MFS) have been delineated in this subsurface succession of Jurassic strata from the Loughheed Island area. The MFSs have been placed at the change in gamma log trend from increasing gamma ray to decreasing gamma ray. This change in gamma ray trend is interpreted to reflect a change from fining and deepening-upward (increasing clay content) to coarsening and shallowing-upward (decreasing clay content).

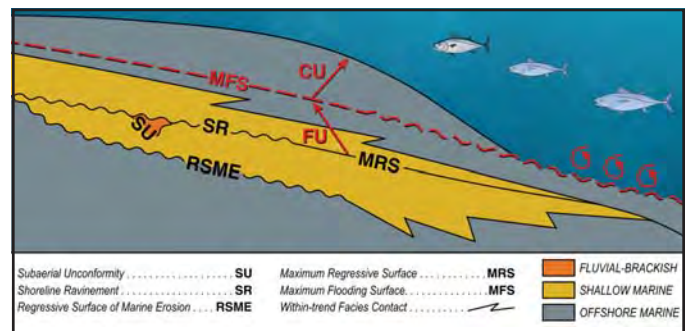

Figure 6.4. A schematic diagram showing the interpreted relationship between a maximum flooding surface (MFS) and other surfaces of sequence stratigraphy. The MFS overlies the SU/SR-U/MRS surfaces and, as shown, represents the change in trend from fining to coarsening. The surface develops close to the time of onset of regression when the shoreline begins to move seaward and coarser sediment arrives at a given locality on the shelf. In distal areas, the MFS can be an unconformity due to starvation and episodic scouring and it is downlapped by prograding sediment.

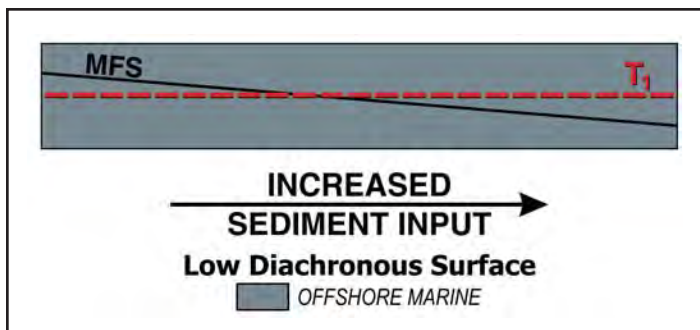

Figure 6.5. The relationship of the maximum flooding surface (MFS) to time. The MFS will approximate a time surface perpendicular to the shoreline but will exhibit minor diachroneity along strike due to varying rates of sediment input along the shoreline. It will develop earlier (i.e., be older) in areas of higher input where regression begins earlier.

(2001) included the SOS as one of the six surfaces of sequence stratigraphy. It is a prominent, unconformable surface which is developed in slope environments and is characterized, above all else, by the onlap of strata onto the surface. The strata below the SOS can be either concordant with the SOS without any evidence of scour or erosion or can be clearly scoured and / or truncated. In cases where the SOS is not scoured, the surface is one of starvation onto which younger beds onlap. Where there is scour and loss of section below the SOS, the surface is formed in part by erosion (gravity collapse, current scour) followed by onlap.

The SOS is best expressed in carbonate strata in a shelf / slope / basin physiographic setting (Figures 6.6, 6.7) and is often readily seen in outcrop (Figure 6) and on seismic sections (Schlager, 2005). The SOS forms when carbonate production is greatly reduced due to exposure of the platform (carbonate factory) during base-level fall. When this occurs, most of the slope is starved of sediment.

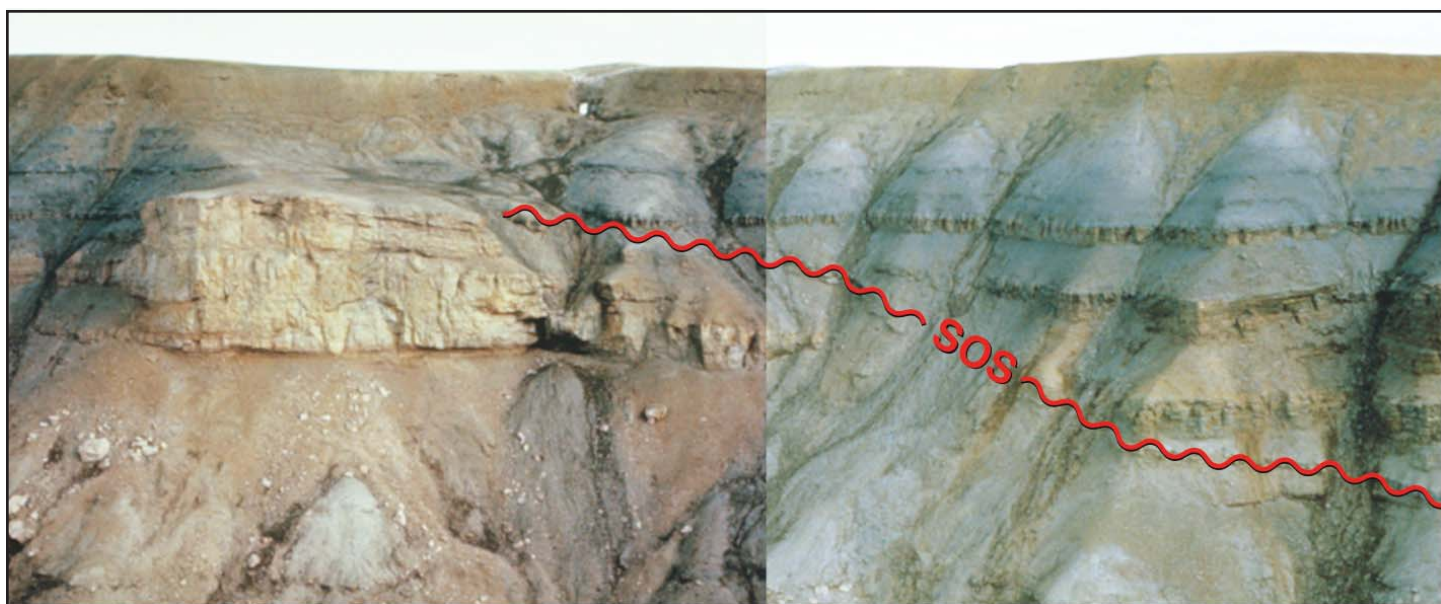

Figure 6.6. In this outcrop of an upper Devonian patch reef on northeast Banks Island, shelfal strata occur to the left of the reef and a basin occurs to the right. A prominent slope onlap surface (SOS) occurs basinward of the reef and it is onlapped by prograding siliciclastics. See Embry and Klovan (1971) for a description of the geology of this outcrop.

Gjelberg, 1994) and a final transgressive surface (Nummedal et al., 1993). I recommend the name maximum flooding surface, which is by far the most commonly used name, for this surface.

The low diachroneity and occasional time barrier property of the MFS make it potentially a very useful surface for correlation and building an approximate time framework as well as for acting as a boundary for specific sequence stratigraphic units. Its usefulness is greatly enhanced by the fact it can usually be reliably identified in outcrop, well sections, and on seismic data.

Slope Onlap Surface (SOS)

The slope onlap surface is a surface which has been recorded in the geological literature for a long time but which was not given a specific name until Embry (1995) referred to it as a slope onlap surface (SOS). Embry

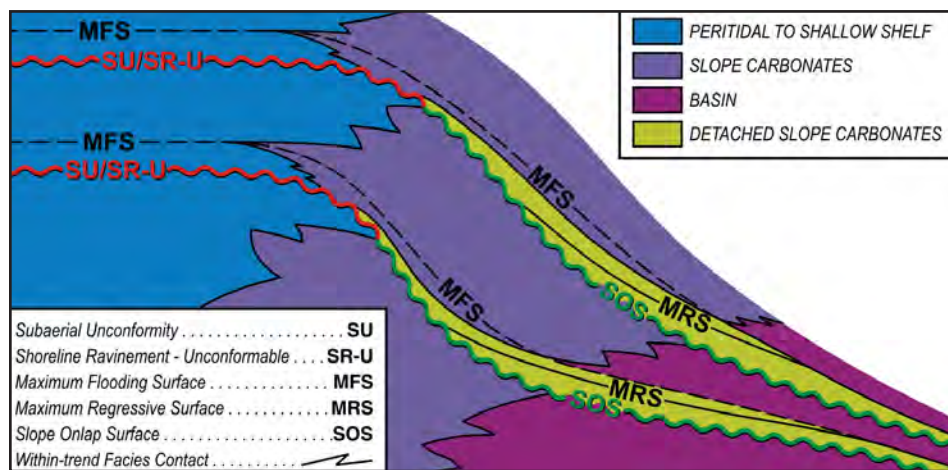

Figure 6.7. A schematic diagram showing the interpreted relationship between a slope onlap surface (SOS) and other surfaces of sequence stratigraphy for a carbonate shelf / slope / basin setting. The SOS develops when the shelf (carbonate factory) is exposed and the slope is starved of sediment. Minor sediment input onlaps the basal portion of the slope as a wedge of detached slope deposits. The upper slope is onlapped by shelf-derived sediment deposited during the early phase of transgression.



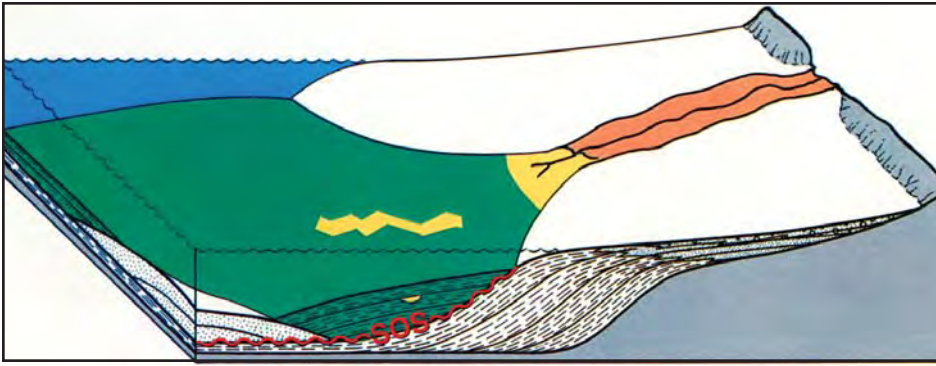

Figure 6.8. This schematic diagram, modified from Figure 3 of Posamentier and Vail (1988), illustrates the formation and characteristics of a slope onlap surface (SOS) in siliciclastic strata. When the shelf edge is exposed, sediment is funneled down submarine channels and a submarine fan is deposited on the basin plain. Most of the slope becomes starved of sediment at this time. Over time, the fan sediments onlap the slope as the locus of fan sedimentation shifts and deposits build up. The upper part of the SOS is usually onlapped by sediments deposited during the subsequent transgression.

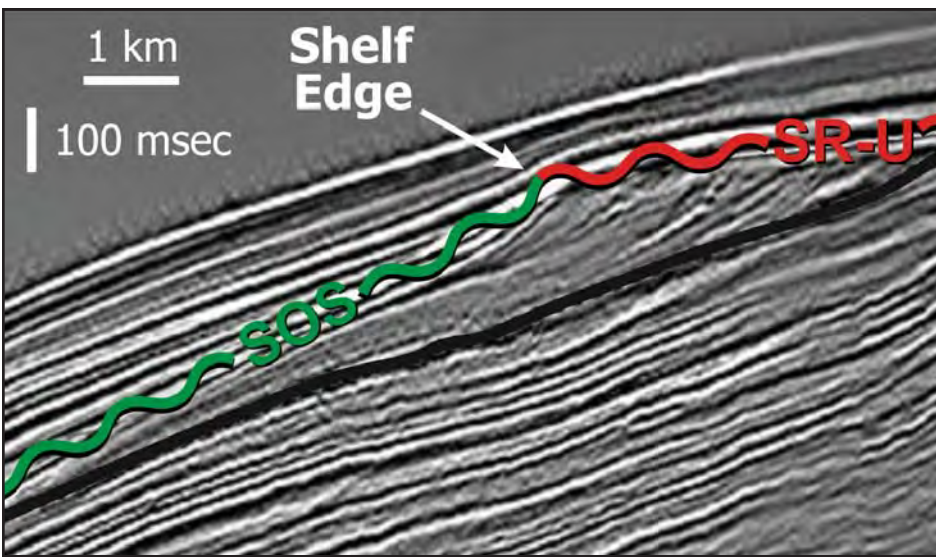

Figure 6.9. A seismically delineated slope onlap surface (SOS) with onlapping strata clearly apparent. Such strata appear to be deposited during transgression and would equate to the “healing phase wedge” of Posamentier and Allen (1993). The SOS adjoins to an interpreted unconformable shoreline ravinement (SR-U) which truncates underlying deltaic strata. Seismic line from Quaternary succession of the Gulf of Mexico, Desoto Canyon area (modified from Posamentier, 2003).

Erosion by margin collapse or by currents can create prominent scarps on the upper slope and feed very coarse sediment down dip where it onlaps the basal portions of the slope. During base-level fall, the slope can be onlapped by prograding siliciclastics as illustrated in Figure 6 or can remain relatively starved, receiving occasional coarse carbonate sediment. During the following base-level rise, the platform is transgressed, widespread carbonate production resumes, and the remainder of the SOS is onlapped by platform-derived, carbonate sediment. Thus the SOS is usually onlapped by sediments deposited during both base-level fall and subsequent base-level rise and transgression. This results in the

maximum regressive surface (MRS) occurring within the onlapping slope sediments (Figure 6.7, page 23).

In shelf / slope / basin settings for siliciclastics, a slope onlap surface also forms when sea level reaches the shelf edge. At this time, sediment flux to the slope changes from being widely distributed before sea level reaches the shelf edge to being areally restricted and concentrated down submarine channels which develop in front of input centres. Such a concentration of sediment flow results in much of the slope being starved of sediment. Once again this starved slope can remain intact or can be eroded by currents or submarine landslides. The slope is eventually onlapped by laterally

expanding fan deposits (Figure 6.8) followed by transgressive sediments deposited during the subsequent base-level rise (Figure 6.9).

In some cases, when falling sea level does not reach the shelf edge, a slope onlap surface can develop at the start of transgression when sediment supply to the slope is substantially reduced due to more accommodation space for sediment being available on the shelf and coastal plain. Early in transgression, the water depth of the shelf is shallow enough to allow most sediment to be swept off the shelf as part of the ravinement process. The shelf-derived sediment onlaps the slope, forming an onlapping, transgressive wedge, which has been called the “healing phase wedge” by Posamentier and Allen (1993). These authors provide a thorough explanation for the formation of an SOS in such a setting. In this case the SOS is onlapped only by transgressive sediment and usually shows no evidence of lost section below it.

Notably, an SOS in siliciclastic sediments is usually very difficult to recognize in outcrop because of the difficulty in establishing onlapping relationships in slope lithologies. However seismic data often images the SOS in siliciclastics (Figure 6.9) and good examples are provided by Greenlee and Moore (1988) and Posamentier and Allen (1999, Figures 4.92, 4.93, 4.94). An SOS can also be delineated on detailed log cross-sections (e.g., Posamentier and Chamberlain, 1993).

A slope onlap surface is an unconformity and is a time barrier. All strata below the surface are older than all strata above. In cases where there has been no removal of strata below the SOS, the SOS can be interpreted as representing a preserved depositional slope which was present at the time of the initiation of the SOS. However, in many cases, strata below an SOS are truncated by the SOS with current erosion and / or gravity collapse having removed part of the stratigraphic record. The time span of the onlapping strata can be highly variable and often ranges from part way into base-level fall (regression) to the early part of base-level rise (transgression). In some cases, only transgressive strata onlap the surface.

Curiously, this distinctive surface has not been given any specific names despite its widespread recognition in both

carbonate and siliciclastic shelf / slope / basin settings. Given the importance of such a surface for correlation, establishing a chronostratigraphic framework, and bounding sequence stratigraphic units, a name is clearly required if only for adequate communication purposes. Galloway and Sylvia (2002) called slope surfaces on which there was significant erosion slope entrenchment surfaces but such a name does not include the common occurrence of slope onlap unconformities where there has no been no loss of section below the unconformity (only on top of it). I named this surface a slope onlap surface (Embry, 1995) and I would recommend the use of this name, which is descriptive and captures the main features of the surface. The time barrier aspect of the surface makes the SOS an important surface for correlation, chronostratigraphic analysis, and for potentially bounding sequence stratigraphic units.

This article concludes the description of the six, material-based surfaces of sequence stratigraphy. As will be described in subsequent articles, these surfaces are the “workhorses” of sequence stratigraphy and are very useful for building an approximate time correlation framework and for bounding material-based sequence stratigraphic units. Before describing such units and illustrating the application of these surfaces for correlation, it is necessary to discuss two time-based surfaces which some workers advocate as equivalents of the six material-based surfaces. These have been named the “basal surface of forced regression” and the “correlative conformity” and they will be discussed in next month’s article.

References

- Allen, G., Lang, S., Musakti, O., and Chirinos, A. 1996. Application of sequence stratigraphy in continental successions: implications for Mesozoic cratonic basins of eastern Australia. *Geological Society of Australia, Mesozoic Geology of the Eastern Australian Plate*. Brisbane, September, 1996. p. 22 - 27.
- Boyd, R., Suter, J., and Penland, S. 1989. Sequence Stratigraphy of the Mississippi Delta. *Gulf Coast Association of Geological Societies Transactions*, v. 39, p. 331-340.
- Cross, T.A. and Lessenger, M. 1998. Sediment volume portioning: rationale for stratigraphic model evaluation and high resolution stratigraphic correlation. In: *Predictive high resolution sequence stratigraphy*. K. Sandvik, F. Gradstein, and N. Milton (eds.). *Norwegian Petroleum Society Special Publication 8*, p.171- 195.
- Embry, A.F. 1995. Sequence boundaries and sequence hierarchies: problems and proposals, In: *Sequence stratigraphy on the northwest European margin*. R.J. Steel, F.L. Felt, E.P. Johannessen, and C. Mathieu (eds). *NPF Special Publication 5*, p. 1-11.
- Embry, A. 2001. The six surfaces of sequence stratigraphy. *AAPG Hedberg Conference on sequence stratigraphic and allostratigraphic principles and concepts*, Dallas. Abstract volume, p. 26–27. http://www.searchanddiscovery.net/documents/abstracts/2001/hedberg_dallas/embry03.pdf.
- Embry, A. and Klován, E. 1971. A Late Devonian reef tract on northeastern Banks Island, NWT. *Bulletin of Canadian Petroleum Geology*, v. 19, p. 730-781.
- Forgotson, J. 1957. Nature, Usage, and Definition of Marker-Defined Vertically Segregated Rock Units. *Geological Notes*. *AAPG Bulletin*, v. 41, p. 2108-2113.
- Frazier, D. 1974. Depositional episodes: their relationship to the Quaternary stratigraphic framework in the northwestern portion of the Gulf Basin. *Bureau of Economic Geology, University of Texas, Geological Circular 74-1*, 26 p.
- Helland-Hansen, W. and Gjelberg, J. 1994. Conceptual basis and variability in sequence stratigraphy: a different perspective. *Sedimentary Geology*, v. 92, p. 1-52.
- Galloway, W.E. and Sylvia, D.A. 2002. The many faces of erosion: theory meets data in sequence stratigraphic analysis. In: *Sequence stratigraphic models for exploration and production*. J. Armentrout and N. Rosen (eds.). *Gulf Coast SEPM Conference Proceedings*, Houston, p. 99-111.
- Greenlee, S. and Moore, T. 1988. Recognition and interpretation of depositional sequences and calculation of sea-level changes from stratigraphic data – offshore New Jersey and Alabama. In: *Sea level changes: an integrated approach*. C. Wilgus, B.S. Hastings, C.G. Kendall, H.W. Posamentier, C.A. Ross, and J.C. Van Wagoner (eds.). *SEPM Special Publication 42*, p. 329-353.
- Hamilton, D., and Tadros, N. 1994. Utility of coal seams as genetic stratigraphic sequence boundaries in nonmarine basins: an example from the Gunnedah Basin. *AAPG Bulletin*, v. 78, p. 267-286.
- Loutit, T., Hardenbol, P., Vail, P., and Baum, G. 1988. Condensed sections: the key to age dating and correlation of continental margin sequences. In: *Sea level changes: an integrated approach*. C. Wilgus, B.S. Hastings, C.G. Kendall, H.W. Posamentier, C.A. Ross, and J.C. Van Wagoner (eds.). *SEPM Special Publication 42*, p. 183-216.
- Nummedal, D., Riley, G., and Templet, P. 1993. High resolution sequence architecture: a chronostratigraphic model based on equilibrium profile studies. In: *Sequence stratigraphy and facies association*. H. Posamentier, C. Summerhayes, B. Haq, and G. Allen (eds.). *International Association of Sedimentologists, Special Publication 18*, p. 55-68.
- Oliver, T. and Cowper, N. 1963. Depositional environments of the Ireton formation, Central Alberta. *Bulletin of Canadian Petroleum Geology*, v. 11, p. 183-202.
- Plint, G., McCarthy, P., and Faccini, U. 2001. Nonmarine sequence stratigraphy: updip expression of sequence boundaries and systems tracts in a high resolution framework, Cenomanian Dunvegan Formation, Alberta foreland basin, Canada. *AAPG Bulletin*, v. 85, p. 1967-2001.
- Posamentier, H. 2003. A linked shelf-edge delta and slope-channel turbidite system: 3d seismic case study from the eastern Gulf of Mexico. In: *Shelf margin deltas and linked down slope petroleum systems*. H. Roberts, N. Rosen, R. Fillon, and J. Anderson (eds.). *Proceedings of the 23rd GCSSEM conference*, p. 115-134.
- Posamentier, H. and Vail, P. 1988. Eustatic controls on clastic deposition II – sequence and systems tract models, In: *Sea level changes: an integrated approach*. C. Wilgus, B.S. Hastings, C.G. Kendall, H.W. Posamentier, C.A. Ross, and J.C. Van Wagoner (eds.). *SEPM Special Publication 42*, p. 125-154.
- Posamentier, H. and Chamberlain, C. 1993. Sequence stratigraphic analysis of Viking Formation lowstand beach deposits at Joarcam Field, Alberta, Canada. In: *Sequence stratigraphy and facies association*. H. Posamentier, C. Summerhayes, B. Haq, and G. Allen (eds.). *International Association of Sedimentologists, Special Publication 18*, p. 469-485.
- Posamentier, H. and Allen, G. 1993. Variability of the sequence stratigraphic model: effects



of local basin factors. *Sedimentary geology*, v. 86, p. 91-109.

Posamentier, H. and Allen, G. 1999. *Siliciclastic sequence stratigraphy – concepts and applications*. *SEPM Concepts in Sedimentology and Paleontology*, no. 7, 210 p.

Schlager, W. 2005. *Carbonate sedimentology and sequence stratigraphy*. *SEPM Concepts in Sedimentology and Paleontology* 8, 200 p.

Vail, P. et al. 1977. *Seismic stratigraphy and global changes in sea level*. In: *Seismic stratigraphy: applications to hydrocarbon exploration*. Payton, C. (ed.). *AAPG Memoir* 26, p. 49-212.

Van Wagoner, J.C., Posamentier, H.W., Mitchum, R.M., Vail, P.R., Sarg, J.F., Loutit, T.S., and Hardenbol, J. 1988. *An overview of the fundamentals of sequence stratigraphy and key definitions*. In: *Sea level changes: an integrated approach*. C. Wilgus, B.S. Hastings, C.G. Kendall, H.W. Posamentier, C.A. Ross, and J.C. Van Wagoner (eds.). *SEPM Special Publication* 42, p. 39-46.

Van Wagoner, J.C., Mitchum, R.M., Campion, K.M., and Rahmanian, V.D. 1990. *Siliciclastic sequence stratigraphy in well logs, cores and outcrops*. *AAPG Methods in Exploration*, no. 7, 55 p.

Practical Sequence Stratigraphy VII

The Base-Level Change Model for Material-based, Sequence Stratigraphic Surfaces

by Ashton Embry

Introduction

As was described in the previous three articles in this series, six material-based surfaces of sequence stratigraphy, which represent either breaks in sedimentation or changes in depositional trend, were empirically and separately recognized over some 220 years. Furthermore, the origin of each was independently interpreted to be due to the interaction of base-level change and sedimentation, as was also discussed in the past articles. For example, almost 100 years ago, Barrell (1917) postulated that subaerial unconformities formed by a fall in base level.

As part of the revitalization of sequence stratigraphy by Exxon scientists, Mac Jervey (1988) demonstrated that the generation of almost all of these surfaces (the RSME was not considered) can be explained by a model which involves oscillating base level with a constant sediment supply. In this article, I discuss the concept of base level, the factors that cause base level to oscillate, and the generation of the six sequence stratigraphic surfaces during one cycle of base-level rise and fall. I also touch on a point of contention in sequence stratigraphy, which involves two variants of the base-level change model and consequent differences in geometrical relationships between the surfaces.

Base level

Harry Wheeler (1964) succinctly reviewed the history of the use of the term base level in stratigraphy and subsequently Tim Cross (Cross, 1991; Cross and Lessenger, 1998) clearly demonstrated how the concept of base level has direct application to sequence stratigraphy. Base level, in a stratigraphic sense, is not a real, physical surface but rather is an abstract surface that represents a surface of equilibrium between erosion and deposition. It can be thought of as a ceiling for sedimentation and thus, in any area where it lies below the Earth's surface, no sediment accumulation is possible and erosion will occur. Where base level lies above the Earth's surface, deposition can and usually does occur in the space between the Earth's surface and base level. The places where base level intersects the earth's surface are equilibrium points between areas of erosion and areas of deposition. Such points define the edges of a depositional basin.

In a marine area, base level is usually very close to sea level and intersects the sea bottom only where strong currents or waves result in net sediment removal. This results in net deposition for most marine settings. In a nonmarine area, base level most commonly lies at or below the Earth's surface and these areas are thus often subjected to active erosion by a variety of processes. However, in some terrestrial areas, base level can be above the Earth's surface, usually in areas of standing water, and in these situations it usually closely coincides with lake / swamp level. Rivers establish a base level profile which means they aggrade or erode until, with the established water and sediment supply, sediment is not deposited or eroded by the rivers. In this case, base level occurs at the base of the riverbed until a change occurs in water energy, sediment supply, or slope of the channel.

Oscillations of Base Level

Base level can be seen as a surface that is associated with the amount of energy needed to erode sediment. The erosive energy available at any given point may change as a result of eustatic or tectonic activity. This will result in either base-level falling (increased energy) or base level rising (decreased energy) at that point. Because of the dynamic nature of the Earth, base level rarely remains static in any given location and is usually moving upwards or downwards relative to a datum below the surface of the Earth. A datum is used rather than the Earth's surface itself to ensure the concept of base-level change is independent of sedimentation and erosion. Thus base-level changes can be envisioned as changes in the distance between base level and the datum. The space created between the datum and base level, during a specific interval of time has been called

accommodation space (Jervey, 1988) (Figure 7.1). Thus, base-level changes equate to changes in the creation or destruction of accommodation space.

There are two main drivers of regional base-level change (i.e., increased or decreased energy over a substantial part the surface of the Earth). The first one is tectonics that results in upward or downward movements of the reference horizon (datum). In this situation the datum, and not base level, is moving. Downward movement of the datum is referred to as subsidence and, in a relative sense, subsidence results in rising base level and increased accommodation space (i.e., more space between base level and the datum). Conversely, upward movement of the datum (uplift) results in base-level fall as the two reference horizons approach each other and accommodation space is reduced. The second driver of regional base level movement is eustatic sea-level change that records the movements of the surface of the ocean in relation to the centre of the earth (Figure 7.1). In this case, the datum remains stationary and base level, which is closely tied to sea level, moves up or down. Thus, rising eustatic sea level equates to rising base level and increased accommodation space, and falling eustatic sea level equates to falling base level and

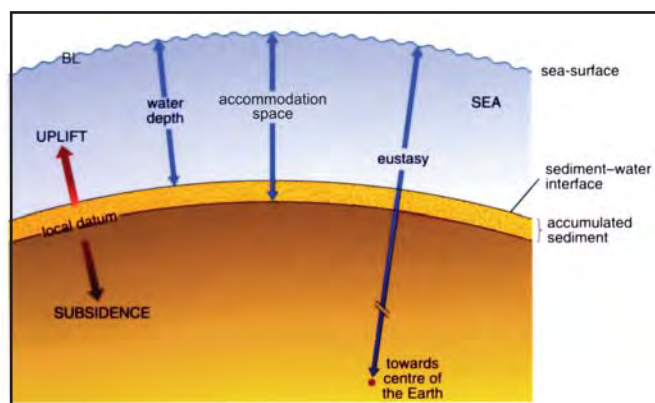

Figure 7.1. Base-level change refers to the relative movement between base level (BL), here equated to sea level, and a datum below the sea floor. Two main factors control base-level change – movement of the datum (uplift, subsidence) and eustatic sea level change. The space between base level and the datum is known as accommodation space (Jervey, 1988). Changes in base level thus equate to changes in accommodation space. Modified from Figure 3.6 of Coe (2003).



decreased accommodation space. Furthermore, any reduction or increase of volume in the sedimentary column due to such phenomena as compaction, salt solution, and salt intrusion also will cause changes in base level and the amount of accommodation space made available.

In addition to the two main drivers of regional base-level change, it must be mentioned that the erosive energy can also change due to local climate variations. For example, when water flow is increased in a river due to a wetter climate, e.g., a monsoon season, the erosive energy level rises, resulting in effectively a base-level fall with consequent downcutting and erosion by the river. Such climate-driven, base-level changes that are independent of tectonics and eustasy are usually local (basin margin) and short-lived and will not be discussed further.

Overall, we know that tectonics and eustasy are the main controls on regional base-level change. However, it is often impossible to determine the effect of each factor separately (Burton et al., 1987). Their combined, net effect is expressed as a change in base level. The term relative sea-level change is sometimes used (Van Wagoner et al., 1988) for a combination of eustatic and tectonic movements but I prefer the term base-level change because it has priority and does not result in any confusion in regards to moving sea level. Use of the term base-level change also avoids often irresolvable arguments of whether tectonics or eustasy is responsible for additions and reductions in accommodation space and the accompanying breaks in sedimentation and changes in depositional trends in given situations.

As noted by Barrell (1917), base level at any given locality is constantly changing due to the interaction of the above factors. Such change is manifest in cycles (episodes) of base-level rise and fall that can occur at a variety of time scales, with a variety of magnitudes, and on local and regional scales. In general, high magnitude base-level changes (i.e., large falls and rises) occur less frequently than do smaller magnitude ones. This is an empirical observation that has great importance for determining a hierarchical arrangement of sequence stratigraphic units. This will be discussed in a later article.

Given that base level is continually changing, the key point for sequence stratigraphy is that such oscillations in base level result in a number of distinct sedimentary surfaces that reflect depositional breaks and / or changes of depositional trend due to the interaction between changing rates of the addition or reduction of accommodation space and the

rate of sedimentation. For example, when accommodation space is eliminated in a given area due to base-level fall below the surface of the earth, there is a major change from sedimentation to erosion and a break in sedimentation occurs. The initiation of erosion potentially results in the occurrence of various types of unconformities that can then be used for correlation and the delineation of sequence stratigraphic units. As emphasized previously, an unconformity represents a significant gap in the stratigraphic record and contrasts with a diastem that records only a minor gap.

Sedimentary Breaks and Changes in Depositional Trends

During a cycle of base-level rise and fall,

Base Level	Events	Surfaces
RISE	Start Regression	Maximum Flooding Surface
FALL	Start Transgression	Maximum Regressive Surface
	Shell Exposed	Slope Onlap Surface
		Subaerial Unconformity and Regressive Surface of Marine Erosion
		Shoreline Ravinement

Figure 7.2. A base-level change model for the generation of the six material-based surfaces of sequence stratigraphy. Each surface is generated during a specific time interval of base-level change due to the interaction of rates of change in accommodation space with sedimentation rates. Modified from Figure 1 of Embry (2002).

various depositional breaks and changes of depositional trend are generated and such changes are represented by the recognized, material-based surfaces of sequence stratigraphy which were described in detail in previous articles (Figures 7.2, 7.3, 7.4). Here I summarize the development of these surfaces during one base-level cycle.

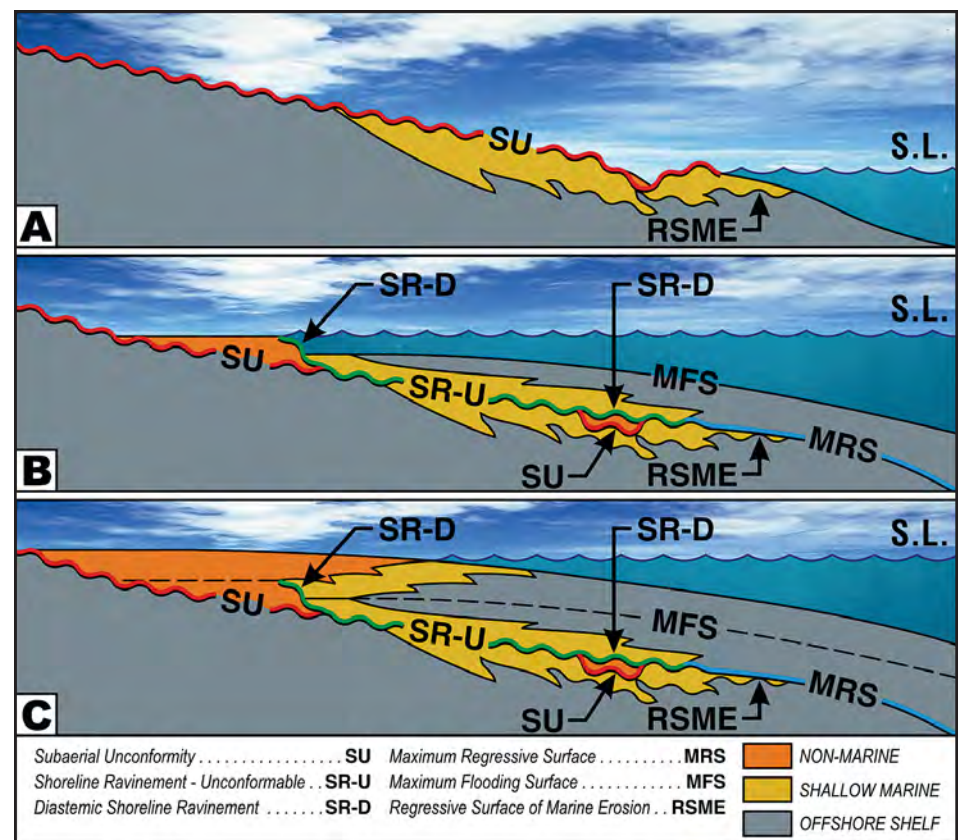

Figure 7.3. Schematic evolution of the five material-based sequence stratigraphic surfaces associated with a ramp setting. (A) By the end of base-level fall (= start base-level rise), the subaerial unconformity (SU) reaches its maximum extent and a regressive surface of marine erosion (RSME) also migrates basinward at the base of shoreface deposits during base-level fall. (b) Transgression begins as base level begins to rise and a shoreline ravinement (SR) migrates landward, eroding portions of the SU. At the same time, finer sediment is deposited at any given marine locality and a maximum regressive surface (MRS) is generated. (C) In the late phase of base-level rise, regression occurs and coarser sediment reaches the marine shelf. A maximum flooding surface (MFS) is generated near the time of maximum transgression and a progradational, coarsening-upward succession then begins to accumulate on the shelf.



With the start of base-level fall, accommodation space begins to be reduced and sedimentation ceases on the basin margin. Subaerial erosion advances basinward during the entire time of fall and this produces a subaerial unconformity (SU) that reaches its maximum basinward extent at the end of base-level fall (Figures 7.2, 7.3A, 7.4A). The seaward movement of the shoreline (regression), which began in the waning stages of base-level rise, continues throughout base-level fall but at a faster pace.

Also, when base level starts to fall, the inner part of the marine shelf in front of the steeper shoreface begins to be eroded as described by Plint (1988). This is due to the erosion of the inner shelf as it is replaced by the shoreface that has a higher slope. This inner shelf erosion surface moves seaward during the entire interval of base-level fall and is progressively covered by prograding shoreface deposits. This results in a regressive surface of marine erosion (RSME) (Figures 7.2, 7.3A). It should be noted that an RSME often does not form due to variable energy levels and base-level fall rates. Also, because such localized, submarine erosion results in only a minor gap in the stratigraphic record at any one locality, an RSME is a highly diachronous diastem rather than an unconformity over its extent.

Finally, when falling sea level reaches a shelf / slope break, sedimentation patterns are substantially altered. In siliciclastics, sediment is channeled down submarine canyons and much of the slope becomes starved. In carbonates, the slope becomes starved at this time because the carbonate factory of the shelf is shut down due to subaerial exposure. Erosion of the slope can also occur due to current scouring and gravity failures. The starved and / or eroded slope is gradually onlapped during the remainder of base-level fall and / or during the early part of base-level rise and transgression and a slope onlap surface (SOS) is thus generated (Figures 7.2, 7.4B).

When base level starts to rise, new accommodation space begins to be created in areas formerly undergoing erosion. This results in landward expansion of the basin margin and progressive onlap of the subaerial unconformity by nonmarine strata throughout the entire time of base-level rise. With rising base level, less sediment is transported to the marine portion of a basin because of reduced fluvial gradients and increased sediment storage in the nonmarine area along the expanding basin margin. In most situations, almost immediately after the start of base-level rise, the shoreline ceases its seaward movement and begins to shift landward (transgression).

Also at this time, less and finer clastic material will reach a given locality in the marine area and the water depth will start to increase. All these changes, which occur at or very soon after the start of base-level rise, result in two surfaces of sequence stratigraphy.

Along the shoreline, the slope of the alluvial plain is less than that of the shoreface and erosion carves out a new shoreface profile during transgression. The erosional surface is known as a shoreline ravinement (SR) and it develops during the entire time transgression occurs (Figures 7.2, 7.3B, 7.4B). This erosional surface almost always cuts down through the basinward portion of the underlying subaerial unconformity (SU) and sometimes erodes most of the SU. This results in segments of a shoreline ravinement being either unconformable (SU eroded) or diastemic (SU preserved) as was described in Part V of this series (Figure 7.3B).

Also, as base level starts to rise and finer sediment starts to be deposited at any given shelf locality due to the overall reduced supply to the marine area, there is a significant change from a coarsening-upward trend that characterized the preceding base-

level fall to a fining-upward one. A described earlier, the horizon that marks this significant change in depositional trend is known as the maximum regressive surface (MRS) (Figures 7.2, 7.3B, 7.4B). The MRS also marks a change from shallowing-upward to deepening-upward in the shallow water areas.

Eventually, the rate of base-level rise slows and sedimentation at the shoreline once again exceeds the rate of base-level rise. The development of the shoreface ravinement stops and the shoreline reverses direction and begins to move seaward (regression). This is associated with increased sedimentation to the marine basin due to less storage capacity in the non-marine area and coarser sediment begins to be deposited at any given shelf locality. This produces a change from a fining-upward trend to a coarsening-upward one and the horizon that marks this change in trend is a maximum flooding surface (MFS) (Figures 7.2; 7.3B, C; 7.4C, D). Notably this surface will approximate the horizon of deepest water in nearshore areas, but in areas farther offshore that have higher rates of base-level rise, the horizon of deepest water will not coincide with the MFS but will be higher in the section.

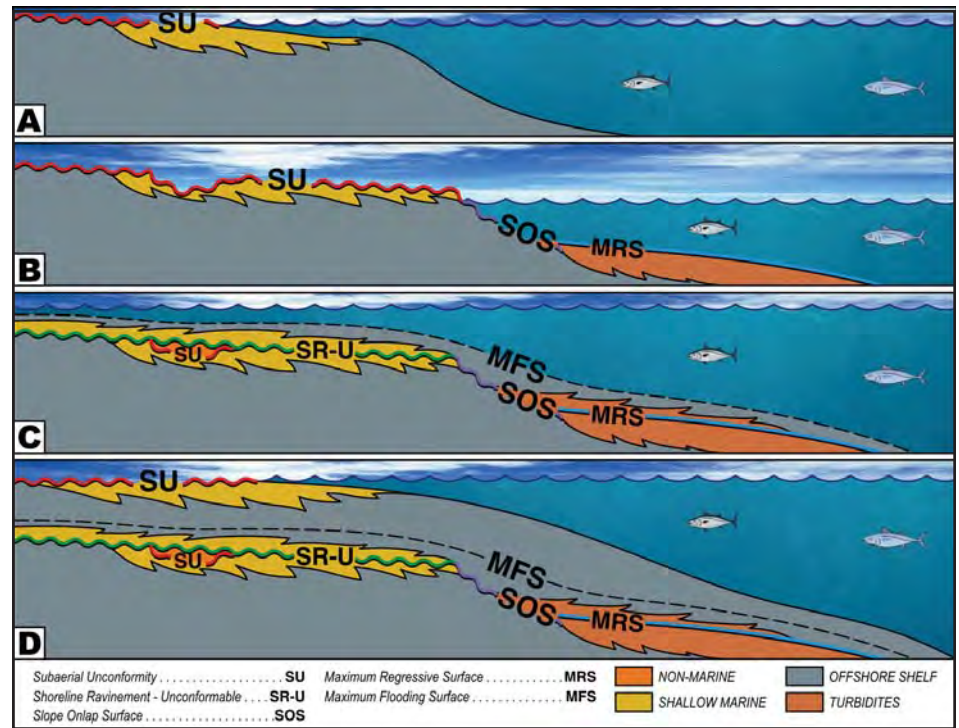

Figure 7.4. Schematic evolution of the six material-based sequence stratigraphic surfaces associated with a shelf / slope/basin setting. (A) During base-level fall the subaerial unconformity (SU) migrates basinward. (b) Late in fall, when the shelf is exposed (SU at shelf edge), a slope onlap surface (SOS) is generated and turbidites begin to be deposited in the basin. At the start of base-level rise, transgression begins and a maximum regressive surface (MRS) is generated in the basinal turbiditic deposits. (C) As transgression proceeds during base-level rise, the shelf is flooded and a shoreline ravinement is cut, removing most of the SU. Finer sediments are deposited in the basin with the horizon of finest sediment marking the maximum flooding surface (MFS). (D) As base-level rise gives way to fall, a wedge of sediment progrades basinward and another SU migrates basinward.



demonstrate that the basinward termination of the SU joins the SR as predicted in the model (e.g., Suter et al, 1987; Pomar, 1991; Embry, 1993; Beauchamp and Henderson, 1994; Johannessen et al., 1995; Mjos et al., 1998; Plint et al., 2001; Johannessen and Steel, 2005; and many others).

The other base level/sediment supply model which has been proposed (Jervey, 1988) is one of very slow, initial base-level rise (slow initial rise model) and it is illustrated in Figure 7.8B. In this case, the SR and MRS are not generated over much of the marine area until well after the start of base-level rise. The reason for this is that sedimentation rates are high enough to exceed the very slow rise rates that occur during the early part of base-level rise in this model. As a result, regression and sediment coarsening on much of the shelf, which occurred during fall, continue during early base-level rise.

Furthermore, because the SR does not start to form until well into base-level rise, it does not cut down through the basinward portion of the SU as it did in the fast initial rise model. Consequently, in the slow initial rise model, there is no material-based surface which connects to the termination of the SU (Figure 7.8B). The ramifications for sequence classification of this lack of a basinward correlative surface for the SU will be discussed in later articles.

I do not favour the slow initial rise model because there are no empirical data to indicate that base-level rise rates are initially very slow. In fact, the opposite appears to occur, as discussed above. Also, empirical stratigraphic relationships established in rock-based studies indicate that the basinward termination of the SU almost always joins the SR, indicating the basinward portion of the SU has been eroded by the SR. These stratigraphic relationships also negate the viability of the slow initial rise model. The only studies, which have been offered in support of the model, are interpretations of seismic data not calibrated with logs and cores (e.g., Posamentier, 2003). These can be reasonably re-interpreted so as to be compatible with the fast initial rise model.

In my next article, I'll elaborate on the time-based approach to sequence stratigraphy and the two time surfaces which are advocated for use in sequence stratigraphy.

References

Barrell, J. 1917. Rhythms and the measurements of geologic time. *GSA Bulletin*, v. 28, p. 745-904.

Beauchamp, B. and Henderson, C. 1994. The Lower Permian Raanes, Great Bear Cape and Trappers Cove formations. *Bulletin of Canadian Petroleum*

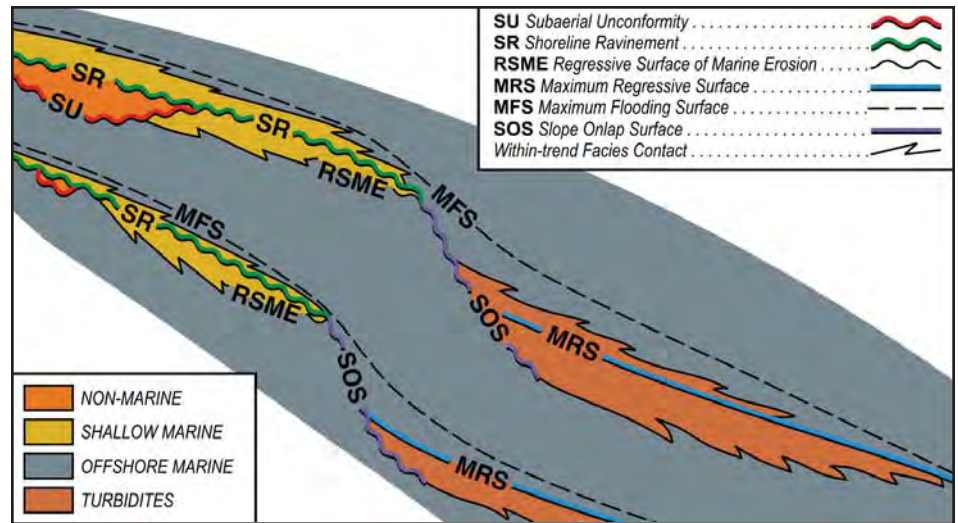

Figure 7.7. A schematic cross section for a shelf / slope / basin setting showing the geometric relationships for the six material-based surfaces of sequence stratigraphy. Once again, a combination of SU and SR-U forms the basin flank unconformity and the basinward termination of the SR-U adjoins the landward termination of the SOS. The MRS onlaps the SOS and the MFS extends across all the physiographic elements

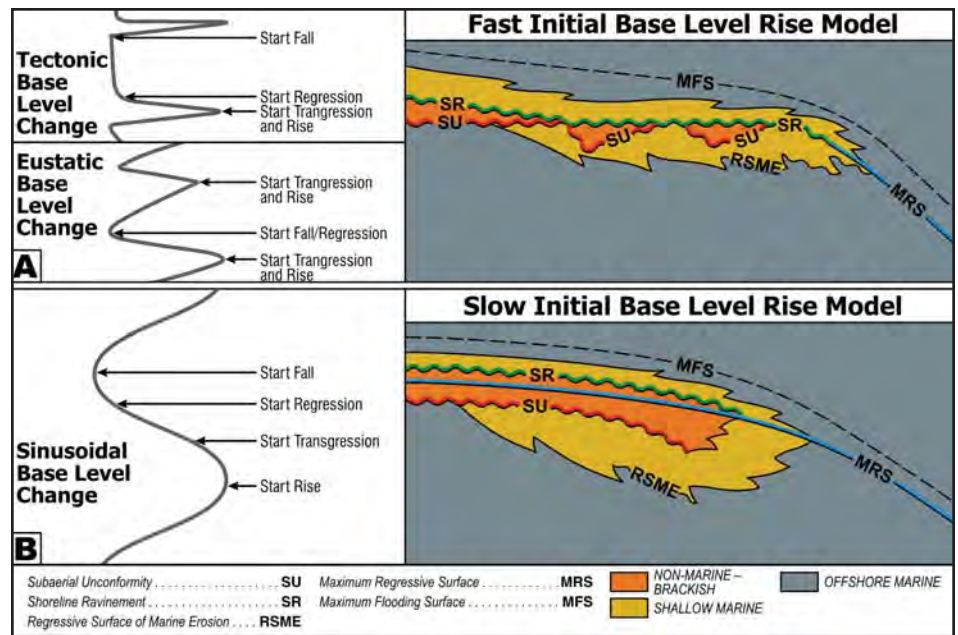

Figure 7.8. Two base-level-change models for sequence stratigraphy for a ramp setting. The same five material-based surfaces are generated in both models. The key difference between the two models is the resulting relationship between the subaerial unconformity and the shoreline ravinement. (A) The fast initial rise model. As shown on the left, both a tectonically-generated and a eustatically-generated base level curve are characterized by rapid initial base-level rise. This results in the shoreline ravinement cutting out the basinward portion of the subaerial unconformity and the surface relationships shown on the right. (B) The slow initial rise model. As shown on the left, early base-level rise is slow on a sinusoidal change curve. In this situation, the shoreline ravinement does not erode the basinward portion of the subaerial unconformity as shown on the right and a wedge of nonmarine sediment always separates the SU from the overlying SR and MRS. Note the basinward termination of the SU does not join with another material-based surface.

Geology, v. 42, p. 562-597.

Burton, R., Kendall, C., and Lerche, I. 1987 Out of our depth: on the impossibility of fathoming eustasy from the stratigraphic record. *Earth Science Reviews*, v. 24, p. 237-277.

Coe, A. (ed.). 2003. The sedimentary record of

sea-level change. Cambridge University Press, New York, 287 p.

Cross, T. 1991. High resolution stratigraphic correlation from the perspective of base level cycles and sediment accommodation. In J. Dolson (ed.). *Unconformity related hydrocarbon exploration and accumulation in clastic and*



carbonate settings. Short course notes, Rocky Mountain Association of Geologists, p. 28-41.

Cross, T.A. and Lessenger, M. 1998. Sediment volume portioning: rationale for stratigraphic model evaluation and high resolution stratigraphic correlation. In K. Sandvik, F. Gradstein, and N. Milton (eds.). Predictive high resolution sequence stratigraphy. Norwegian Petroleum Society Special Publication 8, p. 171-195.

Embry, A.F. 1993. Transgressive-regressive (T-R) sequence analysis of the Jurassic succession of the Sverdrup Basin, Canadian Arctic Archipelago. *Canadian Journal of Earth Sciences*, v. 30, p. 301-320.

Embry, A. 2002. Transgressive-Regressive (T-R) Sequence Stratigraphy, In J. Armentrout, and N. Rosen (eds.). Sequence stratigraphic models for exploration and production. Gulf Coast SEPM Conference Proceedings, Houston, p. 151-172.

Gawthorpe, R., Fraser, A., and Collier, R. 1994. Sequence stratigraphy in active extensional basins: implications for the interpretation of ancient basin fills. *Marine and Petroleum Geology*, v. 11, p. 642-658.

Jervey, M. 1988. Quantitative geological modeling of siliciclastic rock sequences and their seismic expression. In C. Wilgus, B.S. Hastings, C.G. Kendall, H.W. Posamentier, C.A. Ross, and J.C. Van Wagoner, (eds.), *Sea level changes: an integrated approach: SEPM Spec. Pub. 42*, p. 47-69.

Johannessen, E., Mjos, R., Renshaw, D., Dalland, A., and Jacobsen, T. 1995. Northern limit of the Brent delta at the Tampen Spur – a sequence stratigraphic approach for sandstone prediction. In R. Steel, V. Felt, E. Johannessen, and C. Mathieu (eds.). *Sequence Stratigraphy of the Northwest European Margin*. Norwegian Petroleum Society Special Publication 5, p. 213-256.

Johannessen, E.J. and Steel, R.J. 2005. Shelf-margin clinoforms and prediction of deep water sands. *Basin Research*, v. 17, p. 521-550.

Mjos, R., Hadler-Jacobsen, F., and Johannessen, E. 1998. The distal sandstone pinchout of the Mesa Verde Group, San Juan basin and its relevance for sandstone prediction of the Brent Group, northern North Sea. In K. Sandvik, F. Gradstein, and N. Milton, (eds.). Predictive high resolution sequence stratigraphy. Norwegian Petroleum Society Special Publication 8, p. 263-297.

Muto, T., Steel, R. and Swenson, J. 2007. Autostratigraphy: A Framework Norm for Genetic Stratigraphy. *Journal of Sedimentary Research*, v. 77, p. 2-12.

Plint, A. 1988. Sharp-based shoreface sequences and offshore bars in the Cardium Formation of

Alberta: their relationship to relative changes in sea level. In C. Wilgus, B.S. Hastings, C.G. Kendall, H.W. Posamentier, C.A. Ross, and J.C. Van Wagoner, (eds.). *Sea level changes: an integrated approach*. SEPM Special Publication 42, p. 357-370.

Plint, G., McCarthy, P., and Faccini, U. 2001. Nonmarine sequence stratigraphy: updip expression of sequence boundaries and systems tracts in a high resolution framework, Cenomanian Dunvegan Formation, Alberta foreland basin, Canada. *American Association of Petroleum Geologists Bulletin*, v. 85, p. 1967-2001.

Pomar, L. 1991. Reef geometries, erosion surfaces and high frequency sea level changes, Upper Miocene reef complex, Mallorca, Spain. *Sedimentology*, v. 38, p. 243-269.

Posamentier, H. 2003. A linked shelf-edge delta and slope-channel turbidite system: 3d seismic case study from the eastern Gulf of Mexico. In H. Roberts, N. Rosen, R. Fillon, and J. Anderson, (eds.). *Shelf margin deltas and linked down slope petroleum systems*, Proceedings of the 23rd GCSSEPM conference, p. 115-134.

Shackleton, N.J. 1987. Oxygen isotopes, ice volume and sea level. *Quaternary Science Reviews*, v. 6, p. 183-190.

Suter, J., Berryhill, H., and Penland, S. 1987. Late Quaternary sea level fluctuations and depositional sequences, southwest Louisiana continental shelf. In D. Nummedal, O. Pilkey, and J. Howard, (eds.). *Sealevel changes and coastal evolution*. SEPM Special Publication 41, p. 199-122.

Van Wagoner, J.C., Posamentier, H.W., Mitchum, R.M., Vail, P.R., Sarg, J.F., Loutit, T.S., and Hardenbol, J. 1988. An overview of the fundamentals of sequence stratigraphy and key definitions. In C. Wilgus, B.S. Hastings, C.G. Kendall, H.W. Posamentier, C.A. Ross, and J.C. Van Wagoner, (eds.). *Sea level changes: an integrated approach*. SEPM Special Publication 42, p. 39-46.



Practical Sequence Stratigraphy VIII

The Time-based Surfaces of Sequence Stratigraphy

by Ashton Embry

Introduction

In parts four, five, and six of this series, I described the six, material-based surfaces of sequence stratigraphy, which have been recognized and characterized over the past 200 years. Notably, each of these material-based surfaces is defined on the basis of observable physical characteristics that include:

- the physical properties of the surface and of overlying and underlying strata and
- the geometrical relationships between the surface and the underlying and overlying strata.

These surfaces can be said to be model-independent because they were empirically recognized before a model was proposed to explain or rationalize their existence. The delineation and use of such surfaces for correlation and for defining specific sequence stratigraphic units constitutes a material-based approach to sequence stratigraphy.

Another approach to sequence stratigraphy, which is advocated by some authors (e.g., Hunt and Tucker, 1992; Helland-Hansen and Gjelberg, 1994; Posamentier and Allen, 1999; Catuneanu, 2006; Catuneanu et al., in press), is a time-based approach. In a time-based approach, some of the surfaces used for sequence stratigraphic analysis are defined on the basis of time rather than observable characteristics and geometrical relationships. Such an approach is indicated by Posamentier (2001) "Critical to a sequence stratigraphic analysis is the identification of time synchronous surfaces that punctuate rock successions".

Time-based surfaces are known as chronostratigraphic surfaces and are defined on the basis of a specified event at an exact location. Basically, a chronostratigraphic surface represents a depositional surface that existed at the moment in time when the specified event took place. As stated by Catuneanu (2006) "Sequence stratigraphic surfaces are defined relative to the four main events of the base-level cycle". Such events are related to a change in either the direction of base-level change (e.g., falling base level to rising base level) or the direction of shoreline movement (e.g., landward movement to seaward movement).

As shown on Figure 8.1, four base level cycle events are defined and utilized in the time-based approach, with the fundamental underpinning of this approach being the hypothesis that each event is associated with a specific, sequence stratigraphic surface. The four events and their assigned surfaces are:

- start base-level rise (1) = correlative conformity,
- start transgression (2) = maximum regressive surface,
- start regression (3) = maximum flooding surface, and
- start base-level fall (4) = basal surface of forced regression.

The time-based approach differs from the material-based approach in two main ways:

- a different way of defining some specific surfaces that are common to both approaches (e.g., maximum regressive surface) and
- the addition of two new surfaces which have no equivalents in the material-based approach.

These two, time-based surfaces were proposed (deduced) by Hunt and Tucker

(1992) on the basis of the sequence stratigraphic model of Jervey (1988) rather than on empirical data. In contrast to the model-independent, material-based surfaces, these two time-based surfaces are model-dependent (i.e., "no model – no surfaces"). They are best viewed as hypothetical surfaces which represent two events on the base level curve.

Old surfaces / new definitions

Two important, material-based, sequence stratigraphic surfaces are the maximum regressive surface (MRS) and maximum flooding surface (MFS) and these surfaces were defined and described in previous articles. As was noted in those articles, both the MRS and MFS were empirically recognized many years (under different names) before sequence stratigraphic methodology and models were formulated and they are defined and delineated solely on the basis of their physical characteristics. As part of modern day, sequence stratigraphic theory, the MRS and MFS are interpreted to have formed due to the interplay of base-level change and sedimentation although it must be emphasized that such interpretations play no role in their definition.

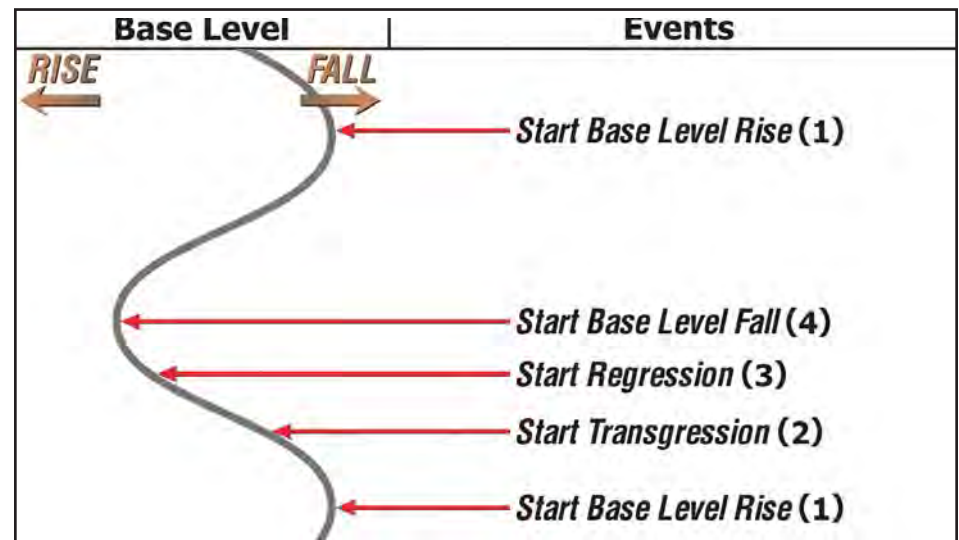

Figure 8.1. A sinusoidal base-level change curve illustrating the timing of the four "events" that are used to define four, time-based surfaces of sequence stratigraphy:

- Start base-level rise = correlative conformity (CC)
- Start transgression = maximum regressive surface (MRS)
- Start regression = maximum flooding surface (MFS)
- Start base-level fall = basal surface of forced regression (BSFR)



In the time-based approach, these two surfaces are defined on the basis of interpreted changes in shoreline direction. For example, Catuneanu (2006, p. 135) states “The maximum regressive surface is defined relative to the transgressive-regressive curve, marking the change from shoreline regression to subsequent transgression”. Similarly, Catuneanu, 2006, p. 142) states “The maximum flooding surface is also defined relative to the transgressive-regressive curve, marking the end of shoreline transgression.”

In reality, the distinction between the two methods – the material-based definitions being dependent on observable characteristics and the time-based ones being dependent on theoretical events - does not have a significant effect on the final result. This is because the observable characteristics used for the material-based definition of a surface are used as proof of the occurrence of the given event associated with that surface. Thus, in most cases the same horizon is picked for a given surface by both approaches although, as will be discussed, this is not always the case. Regardless, it is important to understand the profound difference in the manner in which surfaces are defined in the two approaches as this difference has a significant impact with the introduction of two new surfaces in the time-based approach.

Two New Surfaces

Two, time-based surfaces were introduced into sequence stratigraphy by Hunt and Tucker (1992) on the basis of two theoretical events – start base-level fall and start base-level rise. These surfaces had not been defined before the modeling work of Jervey (1988). One was named the basal surface of forced regression (BSFR) (Hunt and Tucker, 1992) and the other the correlative conformity (CC) (Helland-Hansen and Gjelberg, 1994). Subsequent books (e.g., Posamentier and Allen, 1999; Coe, 2003; Catuneanu, 2006) have advocated for the use of these conceptual, time-based surfaces for sequence stratigraphic unit definition and correlation.

For illustrative purposes, I have added both a BSFR and a CC to model cross-sections which were constructed to show the relationships of the material-based surfaces of sequence stratigraphy. The models represent three different scenarios related to differences in physiography and speed of initial base-level rise:

- ramp setting, fast initial base-level rise (Figure 8.2),
- ramp setting, slow initial base-level rise (Figure 8.3),

- shelf / slope / basin setting, SOS (slope onlap surface)-generated, fast initial base-level rise (Figure 8.4).

The relationships of the two hypothetical time surfaces to the six material-based surfaces for a shelf / slope / basin setting with a slow initial base-level rise is essentially the same as that shown on Figure 8.4. It must be emphasized that the placement of these time-based surfaces on these model cross sections is based on theoretical reasoning and not empirical evidence.

Basal Surface of Forced Regression (BSFR)

Hunt and Tucker (1992, p. 5) defined a BSFR as “a chronostratigraphic surface separating older sediments...deposited during slowing rates of relative sea level rise... from younger sediments deposited during base-level fall”. In short, it represents a time surface generated at the start of base-level fall. Plint and Nummedal (2000), Catuneanu (2006), and Catuneanu et al. (in press) characterize the BSFR as the clinoform (paleo-seafloor) present at the start of offlap (equals start base-level fall at the shoreline) along a given transect perpendicular to the shoreline. From a theoretical point of view, a BSFR will be truncated updip by the SU, will be offset at the RSME and then will occur somewhere within a thick, upward-coarsening succession of shelf and slope strata. Basinward, it will approach the

underlying MFS and may downlap onto it (Figures 8.2-8.4).

Because the BSFR is a time-based surface and does not correspond with any material-based surface of sequence stratigraphy, the obvious question becomes – “Does such a hypothetical surface have any observable, characteristic features that would allow it to be delineated with reasonable objectivity so as to allow it to be used for correlation and bounding sequence stratigraphic units?”

This does not appear to be the case and I believe it is basically impossible to convincingly recognize “the first clinoform associated with offlap” in almost every conceivable geological setting. As shown on Figures 8.2 - 8.4, such a time surface occurs within a succession of coarsening-upward strata and no sedimentological variation or change in grain size trend has been identified or theorized to characterize the surface and allow its recognition in such a succession. This lack of criteria for the recognition of such a surface over most of a basin has been noted by Posamentier et al. (1992), Embry (1995), Posamentier and Allen (1999), Plint and Nummedal (2000), and Catuneanu (2006) – among others. Posamentier et al. (1993, p. 1695) state “This surface becomes a cryptic surface, virtually impossible to identify, where the shoreface deposits become gradationally based”. Posamentier and Allen

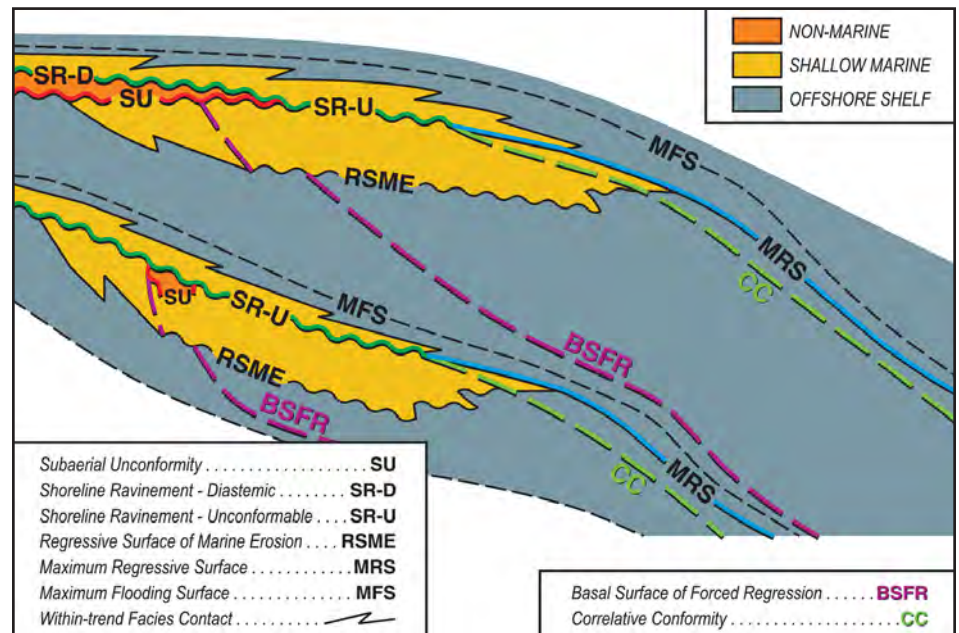

Figure 8.2. A schematic cross-section for a ramp setting with a fast initial base-level rise. Five material-based surfaces of sequence stratigraphy (SU, RSME, SR, MRS, and MFS) and two time-based surfaces (BSFR, CC) are illustrated on the cross-section. The time-based BSFR and CC occur within the coarsening-upwards succession between the material-based MFS and MRS. The BSFR is truncated updip by the SU / SR-U and the CC is truncated very near the basinward end of the SR-U. Neither of these hypothetical time surfaces is marked by any sedimentological changes and, because they are conformities, they are not distinguishable by any geometrical relationships.

(1999, p. 90) state “it exists only as a chronohorizon, ... precise identification ... can be limited”. Plint and Nummedal (2000, p. 5) note that such a time surface is “difficult or impossible to recognize in outcrops or well logs”. Catuneanu (2006, p. 129) states “the basal surface of forced regression ... has no physical expression in a conformable succession of shallow water deposits”. Thus it appears widely accepted that the BSFR has no characteristic physical attributes to allow its objective recognition in well exposed sections or in core.

Authors who advocate the use of the conceptual BSFR in sequence stratigraphic classification offer two ways of delineating such a surface. One is through the use of seismic data, and authors such as Posamentier and Allen (1999) and Catuneanu (2006) suggest a BSFR can be approximated by the seismic reflector that intersects the SU (subaerial unconformity) at the start of a downward trajectory of the SU (i.e., start oflap). In theory, this has some merit, but the main problem with such a proposal is that subsequent erosion on the subaerial unconformity during the entire time of base-level fall destroys such a geometrical relationship. Consequently it is virtually impossible to identify on seismic sections or well log sections the “clinof orm which intersects the SU at the start of oflap” except in extremely rare cases.

The other strategy for delineating a BSFR is to use one of the material-based surfaces of sequence stratigraphy or, in some cases, a lithostratigraphic surface (within-trend facies change) as a “proxy” for it. Some authors have associated a BSFR with a regressive surface of marine erosion (RSME) (e.g., Posamentier et al., 1993). However, as described in part 4 of this series (Embry, 2008a), the RSME is a highly diachronous surface which forms during the entire time of base-level fall and is almost entirely younger than the time-based BSFR (Plint and Nummedal, 2000).

Sometimes, in offshore shelf environments, sedimentation on the unconformable portion of an MFS is interpreted not to have begun until after base level starts to fall (i.e., outer shelf initially starved after the start of regression) and that portion of the MFS is sometimes labeled as a BSFR (e.g., MacNeil and Jones, 2006, Fig. 11; Catuneanu, 2006, Fig. 4.19). However, such a surface should be recognized as an MFS rather than a BSFR as a BSFR is a chronostratigraphic surface and thus cannot be an unconformity. In theory, the BSFR in the above-cited cases would have downlapped onto the MFS, although even this would be very difficult to demonstrate in a real-world situation.

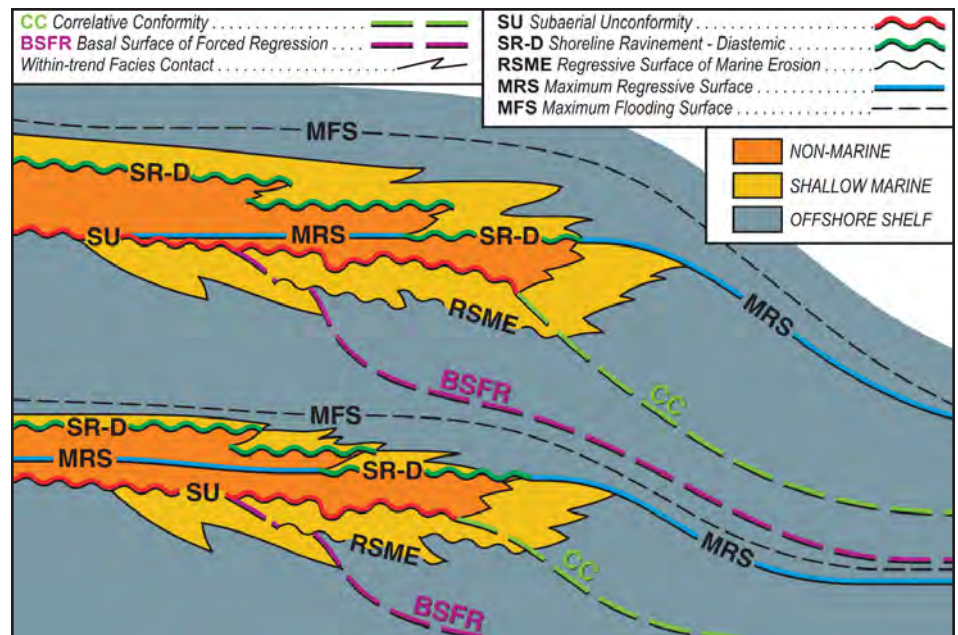

Figure 8.3. A schematic cross section for a ramp setting with a slow initial base-level rise. Once again the BSFR and CC occur in the coarsening-upward succession between the MFS and MRS. In this model, the landward end of the CC adjoins the basinward termination of the SU. Unlike the fast initial rise model, the CC and MRS are separated by a substantial thickness of sediment and the SR does not erode the basinward portion of the SU. Also in this model, a time-based MRS is hypothesized to occur within nonmarine strata. As with the time-based BSFR and CC, no concrete criteria have ever been proposed for delineating a time-based MRS in nonmarine strata.

Another material-based, sequence stratigraphic surface which is occasionally equated to a BSFR is the slope onlap surface (SOS) (e.g., Posamentier and Allen, 1999). Once again, such a comparison is inappropriate because an SOS always develops after the start of base-level fall. For siliciclastics, this will almost always be a

significant time after the start of base-level fall. Furthermore, an SOS is often an unconformity (Embry, 2008b).

Two commonly used proxies for a BSFR involve the use of highly diachronous facies changes at the base of turbidite strata or at the base of shallow water carbonate or

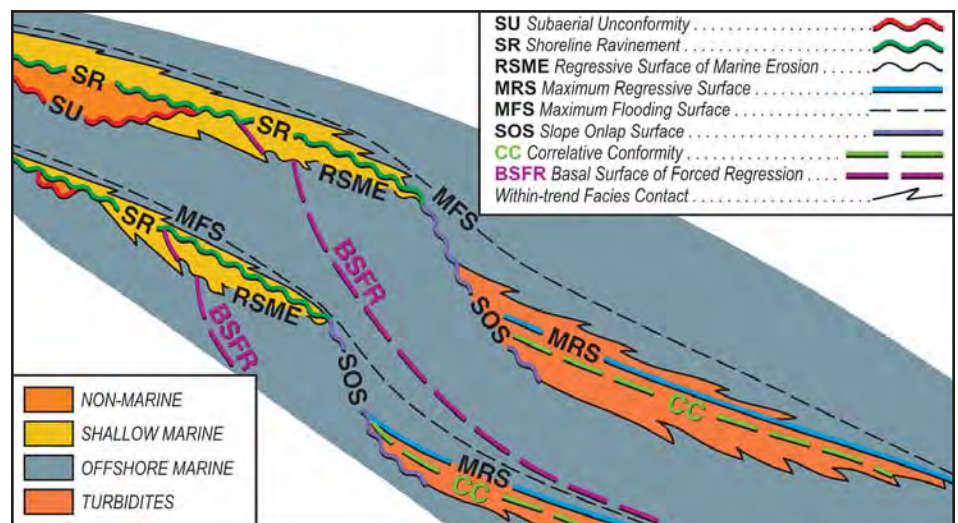

Figure 8.4. A schematic cross-section for a shelf / slope / basin setting showing the geometric relationships for the six material-based surfaces of sequence stratigraphy as well as the two time-based ones. Similar to the other models, the BSFR is truncated updip by the SU / SR-U. It occurs within the coarsening-upward succession between the MFS and MRS and, in some cases, will downlap onto the MFS basinward. The CC occurs in the basinal turbidites and may coincide with or lie just below the material-based MRS. It onlaps the slope onlap surface (SOS). The BSFR and CC placement on this and the other schematic cross sections is based solely on model-based deduction.



clastic strata (e.g., Hunt and Tucker, 1992; Plint and Nummedal, 2000; Mellere and Steel, 2000; Coe, 2003; Catuneanu, 2006, and very many others). The obvious pitfall in using the base of submarine fan deposits as an equivalent of a BSFR is that it is highly unlikely the first gravity flow deposits will coincide, or even be remotely close to coinciding, with the start of base-level fall. Turbidite deposition can be initiated any time during fall and, in many cases, does not occur at any time during fall (Catuneanu, 2006). The same logic applies to the use of the highly diachronous, basal contact of a shallow marine deposit for a BSFR (e.g., Burchette and Wright, 1992). Such a facies contact forms throughout the entire interval of fall as the shallow water facies progrades basinward over deeper water facies. A serious problem of trying to equate a BSFR with inappropriate material-based surfaces as discussed above is that such a practice can result in misleading and erroneous interpretations of depositional history.

Given the above arguments, a BSFR is best seen as a purely deductive construct (i.e., hypothetical surface) which has no characteristic physical attributes to allow its recognition in well exposed strata, in core, and on almost all seismic lines. Despite these issues, the BSFR has been proposed as both a sequence boundary (Posamentier and Allen, 1999) and a systems tract boundary (Hunt and Tucker, 1992; Plint and Nummedal, 2000; Catuneanu, 2006). The practicality of employing a “cryptic”, time-based surface as a unit boundary will be discussed in forthcoming articles that look at how sequence stratigraphic units are defined.

Correlative Conformity (CC)

Hunt and Tucker (1992, p. 6) characterized a correlative conformity, as “truly a chronostratigraphic surface” equivalent to the depositional surface (clinoform) at the end of base-level fall (i.e., start base-level rise). It represents the sea floor at the moment in time when base-level fall gives way to base-level rise. Like the BSFR, a CC is model-dependent and had not been described as a distinct surface before the Jervey (1988) model for explaining the origin and geometries of sequence stratigraphic surfaces was published. Hunt and Tucker (1992) did not provide any specific criteria which would allow the recognition of a CC except in areas of submarine fan deposition. Helland-Hansen and Gjelberg (1994), Helland-Hansen and Martinsen (1996), and Catuneanu (2006) have elaborated on this surface and advocated for its use in sequence stratigraphic classification.

From a theoretical point of view, the CC joins the basinward end of the subaerial

unconformity (SU) in a ramp setting for the slow initial rise model (described in part 7 of this series) (Figure 8.3, page 37). Basinward, it occurs within a coarsening-upward succession situated between the MFS below and the MRS above. In a ramp setting for the fast initial rise model, the CC will be truncated at the end of the unconformable shoreline ravinement (SR-U) (Figure 8.2, page 36). In a shelf / slope / basin model, where an SOS develops, and for either slow or fast initial base-level rise, the CC will theoretically occur in a succession of basinal turbidites and will overlap the SOS (Figure 8.4, page 37).

To my knowledge, no one has ever published any observable criteria for recognizing the correlative conformity over most of a basin. This is not surprising given that no sedimentary break or change in sedimentation style or trend occurs over much of the marine area at the start of base-level rise, especially when base-level rises slowly at the start (Figure 8.3, page 37).

This lack of observable characteristics is recognized by Catuneanu (2006, p. 122) who states “The main problem relates to the difficulty of recognizing it in most outcrop sections, core or wireline logs.” As Catuneanu (2006) explains, the correlative conformity “develops within a conformable prograding package (coarsening upward trends below and above); lacking any lithofacies and grading contrasts”. The main problem associated with the correlative conformity is also enunciated by Plint and Nummedal (2000, p. 5) who succinctly state “From a practical point of view, this marine surface will be difficult to impossible to identify.”

Catuneanu (2006) and Catuneanu et al. (in press) suggest that seismic data offer the best opportunity to identify and correlate a CC. A CC can be approximated by a basinward seismic reflector which joins with a more landward reflector that encompasses the SU and / or the SR-U. Catuneanu (2006) interprets such a seismic-based CC in his Figure 4.17. As shown in Figure 8.2 (page 34), the MRS and the CC will theoretically almost coincide when the start of transgression occurs very soon after start of base-level rise and perhaps more importantly, the MRS adjoins to the basinward end of the unconformity. In this case the seismic reflector which encompasses a theoretical CC will also encompass a material-based MRS. The question remains if a seismically recognized, time-based CC for a ramp setting is in actuality a material-based MRS. I suspect it is in most, if not all cases, but we need studies involving core and seismic to resolve the

question of whether or not a CC is a real surface which has physical properties that can generate a seismic reflector. The other material-based surface which is sometimes labeled as a CC on seismic is the slope onlap surface (SOS). The reason for such a portrayal is shown in Figure 8.4 (page 37), which illustrates that the landward termination of the SOS adjoins the basinward termination of the basin flank unconformity (SU or SU / SR-U). Thus the same seismic reflector that encompasses the SU / SR-U on the basin flank encompasses the SOS farther basinward.

Hunt and Tucker (1992) suggested that the change from a coarsening-upward succession of turbidites to a fining-upward succession might approximate such a boundary and this has theoretical support (Catuneanu, 2006). However, the material-based maximum regressive surface would also be placed at such a horizon of change in depositional trend (coarsening trend changing to a fining trend). Notably, Catuneanu (2006) and Catuneanu et al. (in press) would not put the time-based MRS at this horizon, but rather would place it stratigraphically higher at an often unrecognizable (“cryptic”) horizon within shaly turbidites. The position of this horizon depends on a specific sequence stratigraphic model.

This significant difference in the placement of the MRS in deep water strata highlights the essential difference between the two approaches to surface definition. The material-based approach uses an MRS with defined, observable criteria whereas the time-based approach uses a theoretical, model-dependent, indefinite horizon for the MRS.

In summary, the correlative conformity, although it has theoretical appeal, is a time-based, sequence-stratigraphic surface lacking defining characteristics which would allow such a surface to be recognized with reasonable scientific objectivity (i.e., with empirical observations) in most data sets. Despite these formidable problems, the CC has been proposed as both a sequence and systems tract boundary (Hunt and Tucker, 1992; Plint and Nummedal, 2000; Catuneanu, 2006). The practicality of such usage will be discussed in future articles in this series.

With this article, all the various specific types of sequence stratigraphic surfaces which have been recognized / proposed, including both material-based ones and time-based ones, have been described. Such surfaces provide the means for defining a variety of specific types of sequence stratigraphic units. Material-based sequence stratigraphic units are defined by various combinations of



bounding, material-based surfaces. Time-based sequence stratigraphic units employ the time-based surfaces discussed above, in addition to material-based surfaces, for defining unit boundaries. The existence of both material-based units and time-based units has been a major source of confusion for those wanting to employ sequence stratigraphic units in their studies and to communicate their findings. In the next article, I will describe and evaluate the practicality of the different types of sequences, both material-based and time based, which have been proposed for use. In subsequent articles, I'll tackle systems tracts, followed by parasequences.

References

Burchette, T. and Wright, V.P. 1992. Carbonate ramp depositional deposits. *Sedimentary Geology*, v. 79, p. 3-57.

Catuneanu, O. 2006. *Principles of Sequence Stratigraphy*. Elsevier, New York, 375 p.

Catuneanu, O. et al. In press. Towards the Standardization of Sequence Stratigraphy. *Earth Science Reviews*.

Coe, A. (ed.) 2003. *The sedimentary record of sea-level change*. Cambridge University Press, New York, 287 p.

Cross, T. 1991. High resolution stratigraphic correlation from the perspective of base level cycles and sediment accommodation. In: *Unconformity related hydrocarbon exploration and accumulation in clastic and carbonate settings*. J. Dolson (ed.). Short course notes, Rocky Mountain Association of Geologists, p. 28-41.

Embry, A.F. 1995. Sequence boundaries and sequence hierarchies: problems and proposals. In: *Sequence stratigraphy on the northwest European margin*. R. J. Steel, F. L. Felt, E.P. Johannessen, and C. Mathieu (eds.). NPF Special Publication 5, p. 1-11.

Embry, A.F. 2008a. *Practical Sequence Stratigraphy IV: The Material-based Surfaces of Sequence Stratigraphy, Part 1: Subaerial Unconformity and Regressive Surface of Marine Erosion*. Canadian Society of Petroleum Geologists, *The Reservoir*, v. 35, issue 8, p 37-41.

Embry, A.F. 2008b. *Practical Sequence Stratigraphy VI: The Material-based Surfaces of Sequence Stratigraphy, Part 3: Maximum Flooding Surface and Slope Onlap Surface*. Canadian Society of Petroleum Geologists, *The Reservoir*, v. 35, issue 10, p 36-41.

Helland-Hansen, W. and Gjelberg, J. 1994. Conceptual basis and variability in sequence stratigraphy: a different perspective. *Sedimentary Geology*, v. 92, p. 1-52.

Helland-Hansen W. and Martinsen, O.J. 1996. Shoreline trajectories and sequences: description of variable depositional-dip scenarios: *Journal of Sedimentary Research*, v. 66, p. 670-688.

Hunt, D. and Tucker, M. 1992. Stranded parasequences and the forced regressive wedge systems tract: deposition during base-level fall. *Sedimentary Geology*, v. 81, p. 1-9.

Jervey, M. 1988. Quantitative geological modeling of siliciclastic rock sequences and their seismic expression, In: *Sea level changes: an integrated approach*. C. Wilgus, B.S. Hastings, C.G. Kendall, H.W. Posamentier, C.A. Ross, and J.C. Van Wagoner (eds.). SEPM Special Publication 42, p.47-69.

MacNeil, A. and Jones, B. 2005. Sequence stratigraphy of a Late Devonian rampsituated reef system in the Western Canadian Sedimentary Basin: Dynamic responses to sea level change and regressive reef development. *Sedimentology*, v. 53, p. 321-359.

Mellere, D. and Steel, R. 2000. Style contrast between forced regressive and lowstand/transgressive wedges in the Campanian of north-central Wyoming (Hatfield Member of the Haystack Mountains Formation). In: *Sedimentary responses to forced regressions*. D. Hunt, and R. Gawthorpe (eds.). Geological Society of London, Special Publication 172, p. 141-162.

Plint, A. and Nummedal, D. 2000. The falling stage systems tract: recognition and importance in sequence stratigraphic analysis. In: *Sedimentary responses to forced regressions*. D. Hunt, and R. Gawthorpe (eds.). Geological Society of London, Special Publication 172, p. 1-17.

Posamentier, H. 2001. Sequence stratigraphy: Balancing the theoretical and the pragmatic (abstract). *Canadian Society of Petroleum Geologists, The Reservoir*, v. 28, issue 11, p. 14.

Posamentier, H. and Allen, G. 1999. Siliciclastic sequence stratigraphy – concepts and applications. *SEPM Concepts in Sedimentology and Paleontology*, no. 7, 210 p.

Posamentier, H., Allen, G., James, D., and Tesson, M. 1992. Forced regression in a sequence stratigraphic framework: concepts, examples and exploration significance. *AAPG Bulletin*, v. 76, p. 1687-1709.





Practical Sequence Stratigraphy IX

The Units of Sequence Stratigraphy,

Part 1: Material-based Sequences

by Ashton Embry

Introduction

Over the past 50 years, three different, general types of sequence stratigraphic units have been introduced: sequence (Sloss et al., 1949), systems tract (Brown and Fisher, 1977), and parasequence (Van Wagoner et al., 1988). Specific types of sequences and systems tracts have also been defined. Each specific type of sequence stratigraphic unit is primarily defined by the sequence stratigraphic surfaces which bound it. In this article and the next, I will describe the evolution of sequence boundary definition, discuss the two specific sequence types which have become popular, and illustrate the various types of material-based, sequence boundaries which have been introduced into the literature over the past 20 years. The next article will look at time-based sequence boundaries and summarize all the different types of sequence boundaries which have been proposed. The following two articles will look at systems tracts and parasequences, respectively.

Evolving Definition of a Sequence Boundary

In the beginning – As was described in my earlier articles that dealt with the historical development of sequence stratigraphy (Embry, 2008a, b), a sequence was first defined as a stratigraphic unit bound by large-scale, regional unconformities (Sloss et al., 1949). Wheeler (1958) retained this overall definition but included units bound by smaller-scale unconformities. Although a particular type of bounding unconformity was not specified by either Sloss et al. (1949) or Wheeler (1958), applications of this concept in the 1950s and 60s used either subaerial unconformities or unconformable shoreline ravinements as the bounding unconformities of a sequence (e.g., Wheeler, 1958; Sloss, 1963). Because these types of unconformities are, for the most part, confined to the flanks of a basin, and a sequence boundary was restricted to the unconformity, most sequence boundaries and their enclosed sequences could not be correlated over much of the central portions of a basin (see Figure 1 in Embry, 2008a). This greatly limited the practical application of sequences for subdividing the stratigraphic succession of a basin and such

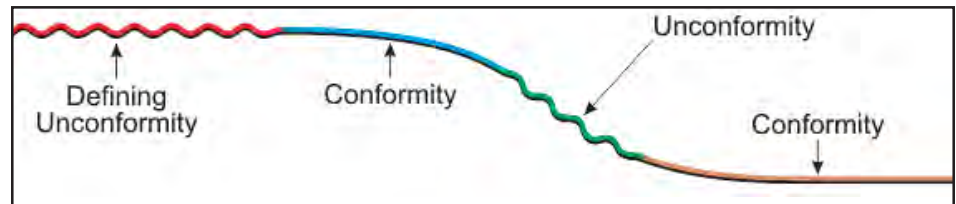

Figure 9.1. A diagrammatic representation of a sequence boundary as a generic surface. A sequence boundary is defined as a specific type of unconformity (red unconformity) and its correlative surfaces (blue conformity, green unconformity, and brown conformity). The correlative surfaces must adjoin to the end of the defining unconformity and join together so as to form one continuous sequence boundary. A specific type of sequence has the same combination of surfaces for both its base and top.

a stratigraphic methodology was not widely applied until 1977.

New definitions – The 1977 watershed publication, *Seismic Stratigraphy - AAPG Memoir 26* (Payton, 1977), contained a series of articles on sequence stratigraphy by Exxon scientists. A key observation was that a seismic reflector that encompassed a basin flank unconformity similar to that used by Wheeler (1958) for bounding a sequence (i.e., characterized by truncation) could be followed basinward where it encompassed submarine unconformities and conformities (Vail et al., 1977). On this basis, the Exxon researchers modified the definition of a sequence from a unit bounded by unconformities to one “bounded by unconformities or their correlative conformities” (Mitchum et al., 1977) and they called such a unit a depositional sequence. This, in effect, defined a sequence boundary as a combination of surfaces rather than one specific type of surface as Sloss et al. (1949) and Wheeler (1958) had done. Most importantly, such a modification allowed sequence boundaries to potentially be correlated across an entire basin and this greatly expanded the application of sequence boundaries for correlation and subdividing the stratigraphic succession of a basin.

In 1988, Exxon scientists modified the definition of a depositional sequence boundary to a subaerial unconformity and correlative conformities (Van Wagoner et al., 1988, p. 41), thus making it a much more specific unit. At the same time, Galloway

(1989) defined a very different type of sequence boundary which he termed a genetic stratigraphic sequence boundary, and it consisted solely of a maximum flooding surface (MFS). Because a portion of an MFS is often unconformable, such a proposed sequence boundary fit the Mitchum et al. (1977) general definition of a sequence boundary but was clearly much different from the depositional sequence boundary of Van Wagoner et al. (1988).

Generic definition – In light of the fact that two specific types of sequences have been defined in the literature, a suitable, generic definition of a sequence is required. To fulfill this need, Embry et al. (2007) defined a sequence as “a stratigraphic unit bound by a specific type of unconformity and its correlative surfaces”. This definition results in a sequence being a general unit and specific types of sequences can be defined and named on the basis of different types of unconformities.

Correlative surfaces are an important part of the generic definition and are essential for allowing a sequence boundary to be extended over all or most of a basin. Correlative surfaces are sequence stratigraphic surfaces which join with the end(s) of the defining unconformity and with each other so as to form one continuous sequence boundary (Figure 9.1). Correlative surfaces can be unconformities, diastems, or conformities and, for maximum utility for subsequent facies analysis in a sequence stratigraphic framework, they preferably



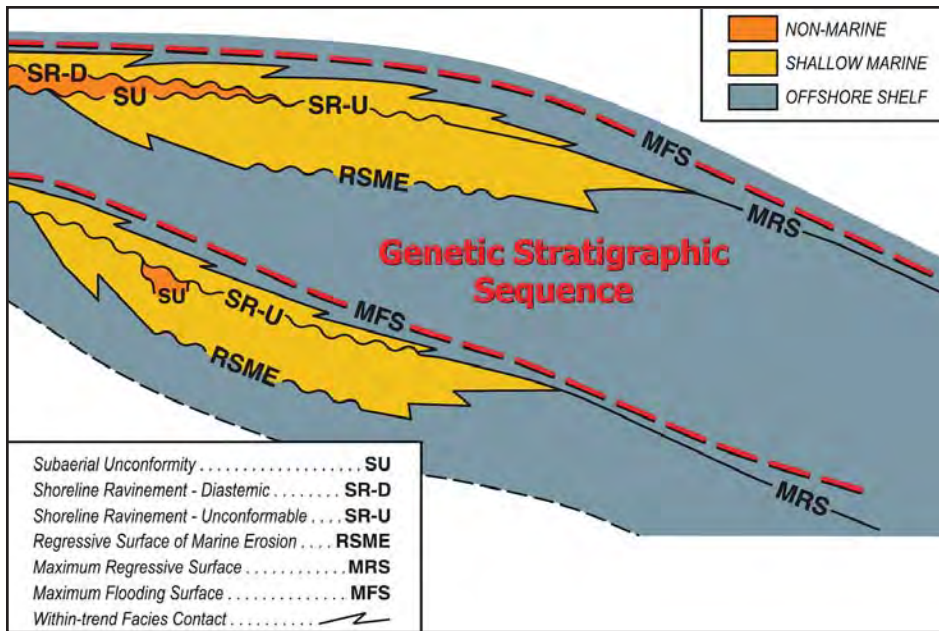

Figure 9.2. The boundaries (MFS) of a genetic stratigraphic sequence are shown in red on this sequence model characterized by a ramp setting with a fast initial base-level rise rate. The boundaries of such a sequence are the same for all sequence models.

have low diachroneity or are time barriers. As will be demonstrated, the current controversies concerning sequence boundaries centre on correlative surfaces.

As noted earlier, two different, specific sequence types have been defined in the literature and are in use today. These are the genetic stratigraphic sequence of Galloway (1989) and the depositional sequence of Mitchum et al. (1977) / Van Wagoner et al. (1988) and they are described below. Other specific sequence types may be defined in the future.

Genetic Stratigraphic Sequence

A genetic stratigraphic sequence was defined by Galloway (1989) and the unconformable portion of the maximum flooding surface (MFS) is the specific type of unconformity which defines this sequence type. The correlative surfaces which compose the remainder of this type of sequence boundary are the diastemic and conformable portions of the MFS. Given that the MFS is a readily recognizable, material-based surface, such a sequence type can be delineated in most cases with objective analysis.

Consequently, a genetic stratigraphic sequence is classified as a material-based sequence type and it is a very straight forward and uncomplicated type of sequence. Its boundaries are illustrated on a ramp, fast-initial-rise sequence model in Figure 9.2. Notably, such boundaries can be delineated, without modification, on any type of sequence model with either a ramp or shelf / slope / basin physiography and with either a slow initial base-level rise or a fast initial

rise. As will be seen, this “one boundary fits all models” situation is not the case with a depositional sequence, and such simplicity is one of the attractive features of a genetic stratigraphic sequence.

The one serious drawback of a genetic stratigraphic sequence is that it commonly encloses a subaerial unconformity or an unconformable shoreline ravinement on the flanks of a basin (Figure 9.2). Given that a major time gap can be associated with such surfaces, not to mention a notable structural discordance, such a sequence is really two, very different genetic units on the basin flanks. However, the MFS is usually the most readily recognizable and objective sequence surface on both logs and seismic sections in the offshore and deep marine areas where subaerial unconformities are absent. In these areas, a genetic stratigraphic sequence clearly has great value for mapping and communication.

Depositional Sequence

Introduction – A depositional sequence was introduced by Mitchum et al. (1977) and the definition was refined by Van Wagoner et al. (1988). The specific type of unconformity that defines this sequence type is a subaerial unconformity. There is no doubt of the need and utility of designating a subaerial unconformity as the defining unconformity for a depositional sequence boundary because of the time gap and significant depositional and tectonic changes which are often associated with such a surface. It was these properties of a subaerial unconformity that led Sloss et al. (1949) to put such a surface on the boundaries of a stratigraphic unit

rather than within it, thus giving birth to the concept of a sequence as a stratigraphic unit.

Multiple depositional sequence boundaries – Unlike the genetic stratigraphic sequence boundary which encompasses only a single surface type (MFS), eight different combinations of a subaerial unconformity with correlative surfaces have been put forward in the literature to constitute a depositional sequence boundary. Thus, it is not hard to understand why there is considerable confusion and controversy when it comes to how one delineates and correlates a depositional sequence boundary.

This wide variety of depositional sequence boundaries results from two main sources. One is the existence of both a material-based approach and a time-based one to sequence stratigraphic classification as has been described in previous articles. Material-based, depositional sequence boundaries use only material-based, sequence stratigraphic surfaces as correlative surfaces whereas time-based, depositional sequence boundaries also use the two time-based surfaces in this capacity. Another source of such diversity is the existence of different sequence models which include specific combinations of either a ramp or shelf / slope / basin physiography with either a slow initial base-level rise rate or a fast initial base-level rise rate. Some of these models were described in previous articles and are used herein to illustrate the different ways in which a depositional sequence boundary has been delineated. Siliciclastic sediments are used in the models but the same stratigraphic surfaces with the same relationships to each other would occur on the models if carbonate sediments were used instead.

Valid correlative surfaces – As a preface to the description and evaluation of each proposed depositional sequence boundary, it is imperative to briefly review the criteria for what constitutes a valid correlative surface for a subaerial unconformity. First of all, any designated correlative surface must be a sequence stratigraphic surface and represent either a break in deposition or a change in depositional trend. Just like magnetostratigraphic surfaces would not be suitable for bounding a biostratigraphic unit, only sequence stratigraphic surfaces can be used as part of the boundary of a sequence stratigraphic unit.

Secondly, because the entire, preserved subaerial unconformity must be part of a given depositional sequence boundary, one of the correlative surfaces has to join with the basinward termination of the defining subaerial unconformity. All of the correlative surfaces then have to join with each other

so as to form one continuous boundary (see Figure 9.1, page 39). Furthermore, given that the subaerial unconformity reaches its maximum basinward extent at the end of base-level fall (Jervey, 1988), correlative surfaces must develop at or soon after the start of base-level rise so as to fulfill this second criteria (Figure 9.3). As illustrated in Figure 9.3, surfaces which develop well before or well after the start of base-level rise will not join with the basinward termination of the subaerial unconformity and thus would not form a continuous boundary which includes all of the subaerial unconformity.

With these fundamental concepts and constraints in mind, the various proposals for a depositional sequence boundary can be evaluated as to their validity and utility. Material-based, depositional sequence boundaries will be examined first, followed by proposed, time-based boundaries.

Material-based, Depositional Sequence Boundaries

Early depositional sequence boundaries

The first, material-based, depositional sequence boundaries were proposed and illustrated by Van Wagoner et al. (1988). They illustrated the boundary on two different sequence models – a shelf / slope / basin with a slow initial rise rate (Figure 9.4A) and a ramp with a slow initial rise rate (Figure 9.5A, page 42).

On their shelf / slope / basin model, the subaerial unconformity occurs on the shelf where it is overlain by nonmarine strata. The basinward termination of the SU joins with a slope onlap surface, which in turn eventually joins with the facies contact at the base of the submarine fan (Figure 9.4A). A slightly different rendition of this model, based on exquisite cliff exposures in Svalbard (Johannessen and Steel, 2005) (Figure 9.4B), better illustrates the Van Wagoner et al. (1988) depositional sequence boundary (SU / SOS / facies change).

The one major flaw which invalidates such a combination of surfaces for a depositional sequence boundary is the inclusion of the facies boundary at the base of the submarine fan strata. This is a lithostratigraphic surface rather than a sequence stratigraphic one and is not a valid correlative surface. As will be subsequently shown, a minor alteration to sequence boundary placement on such a model allows a valid depositional sequence boundary to be drawn.

The Van Wagoner et al. (1988) depositional sequence boundary for a ramp setting with a slow initial rise is more problematic. As shown on Figure 9.5A (page 42), the

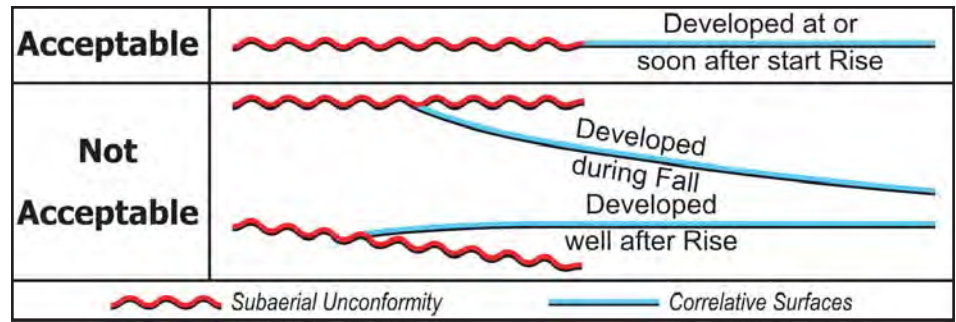

Figure 9.3. A depositional sequence boundary includes all of a given subaerial unconformity by definition. One of the correlative surfaces must join with the basinward termination of the subaerial unconformity to ensure a continuous, through-going, sequence boundary. Because the SU reaches its basinward extent at the end of base-level fall, the correlative surfaces must be developed at or soon after the start of base-level rise to ensure one joins with the end of the SU. Surfaces developed well before or after the start of rise do not join with the end of the SU and a continuous boundary is not possible.

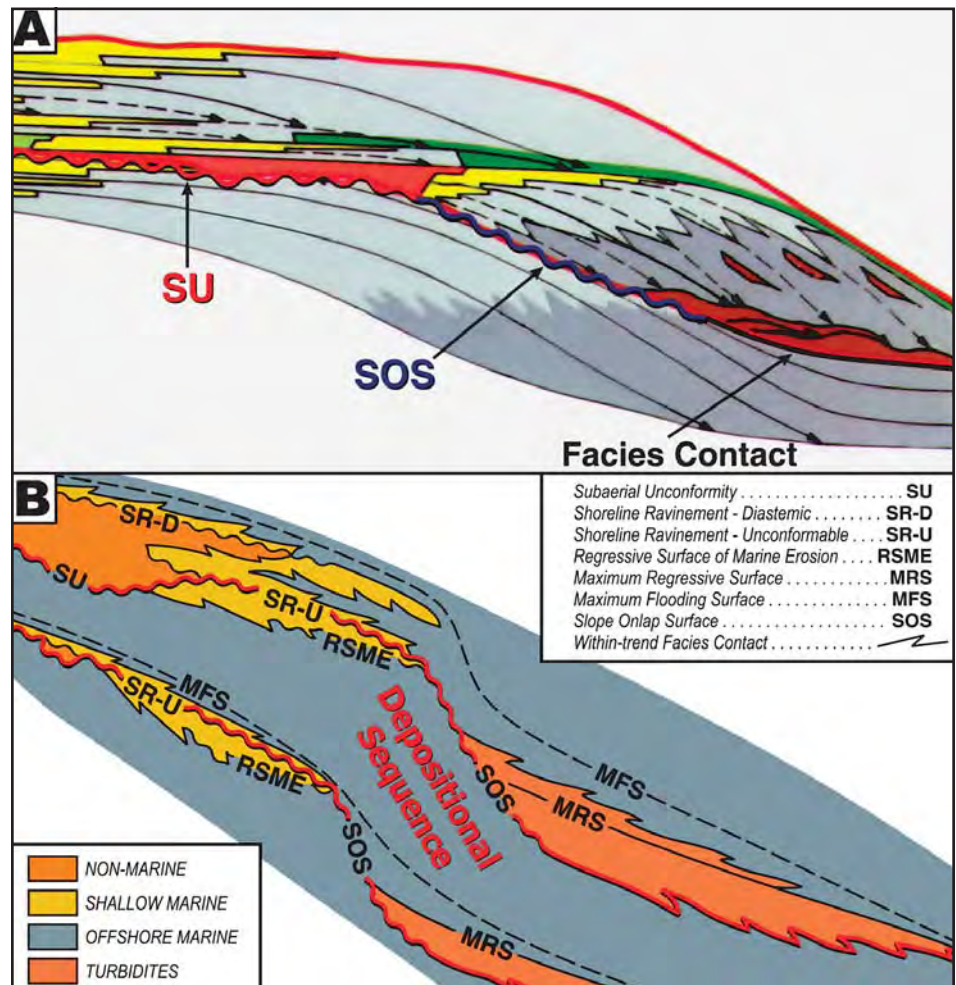

Figure 9.4A. The Van Wagoner et al. (1988) depositional sequence boundary for a shelf / slope setting consists of a subaerial unconformity (SU) on the shelf, a slope onlap surface (SOS) on the slope and the facies change at the base of the submarine fan deposits in the basin (modified from a portion of Figure 2 of Van Wagoner et al., 1988).

Figure 9.4B. A sequence model for a shelf / slope / basin / setting with a slow initial base-level rise based on exposures of Eocene strata on Svalbard (Johannessen and Steel, 2005). The Van Wagoner et al. (1988) depositional sequence boundary is outlined in red.

correlative surfaces employed for such a boundary include the facies change at the base of the shallow water sandstone and a

non-descript surface within the shelf mudstone facies. This non-descript surface may or may not represent an attempt to place



the boundary on a time surface equal to the start of base-level rise (CC). Unfortunately this portion of the boundary is not discussed in their text. This combination of surfaces has no validity for a depositional sequence boundary because it includes a lithostratigraphic surface (facies change) and a completely unknown and uncharacterized surface inside the mudstone facies.

Subsequent studies of the sequence stratigraphy of ramp successions often attempted to apply the Van Wagoner et al. (1988) boundary. In such analyses, the base of a shallow water unit is used as a correlative surface of the SU despite their being no justification for it joining with the termination of the subaerial unconformity and the fact that it is not a surface of sequence stratigraphy. Figure 9.5B illustrates an example of such an invalid depositional sequence boundary which was proposed in a major review of carbonate ramps by Burchette and Wright (1992). Notably, the literature is replete with examples of such inappropriate boundary placement for both carbonates and siliciclastics.

Ramp setting – Stratigraphic relationships in a ramp setting tend to be simpler than those in a shelf / slope / basin setting and this generalization applies to sequence stratigraphy. Figure 9.6 illustrates a sequence model characterized by a ramp physiography and a fast initial base-level rise. As shown, a valid depositional sequence boundary can be readily identified on such a model. The subaerial unconformity is truncated basinward by a shoreline ravinement (SR-U) which in turn joins to a maximum regressive surface (MRS) farther basinward. Thus the SR-U and MRS are correlative surfaces of the SU in this model and all three together form a continuous, depositional sequence boundary from basin edge to basin centre.

Such stratigraphic relationships are created by a fast initial base-level rise rate such that transgression occurs soon after the start of base-level rise and the shoreline ravinement (SR) cuts out the basinward portion of the subaerial unconformity (SU). Notably, a large amount of empirical data for both siliciclastic and carbonate successions confirm the common existence of these stratigraphic relationships (references in Embry, in press) and substantiates the validity and utility of such a depositional sequence boundary (SU / SR-U / MRS).

Figure 9.7 illustrates the sequence stratigraphic relationships for a sequence model which combines a ramp with a slow initial base-level rise rate. In this case, transgression occurs significantly later than the start of base-level rise and the shoreline

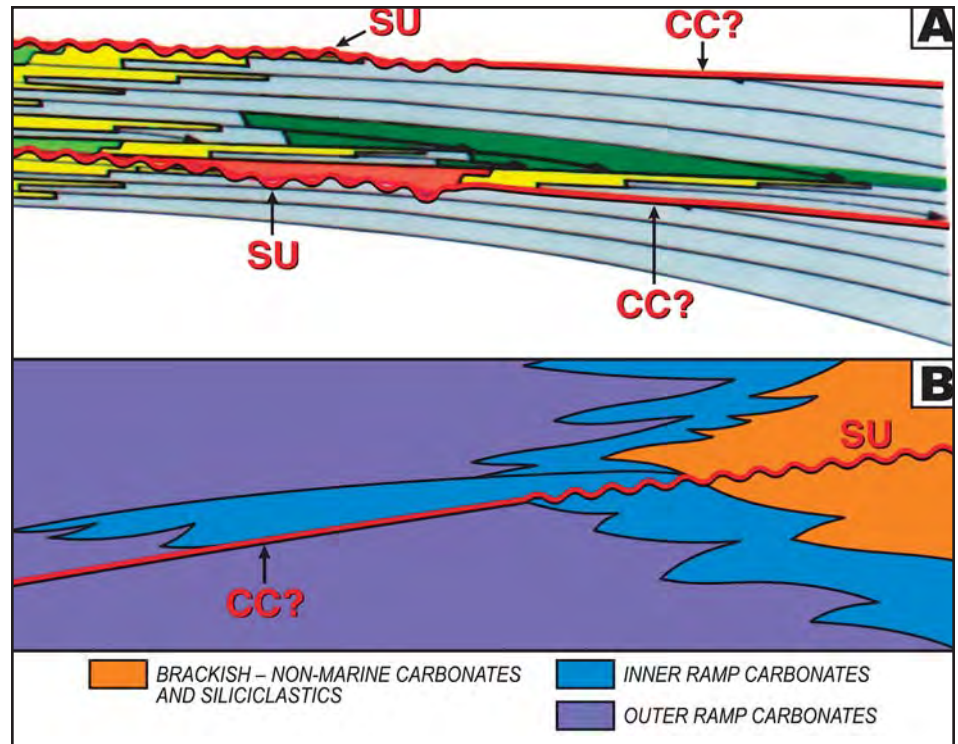

Figure 9.5A. The Van Wagoner et al. (1988) depositional sequence boundary for a ramp setting with a slow initial base-level rise rate consists of a subaerial unconformity (SU), a facies change at the base of shallow water sandstones (yellow) and an unknown surface within the shelf mudstones (grey). This unknown surface may represent the time surface at the start of base-level rise (correlative conformity, CC) (modified from a portion of Figure 3 of van Wagoner et al., 1988).

Figure 9.5B. Proposed placement of a depositional sequence boundary for a carbonate ramp setting (modified from Burchette and Wright, 1992, Figure 13). The authors followed Van Wagoner et al. (1988) and extended the depositional sequence boundary along the facies change at the base of the shallow water carbonates. Such a boundary is invalid because the facies change is a lithostratigraphic surface, not a sequence stratigraphic one.

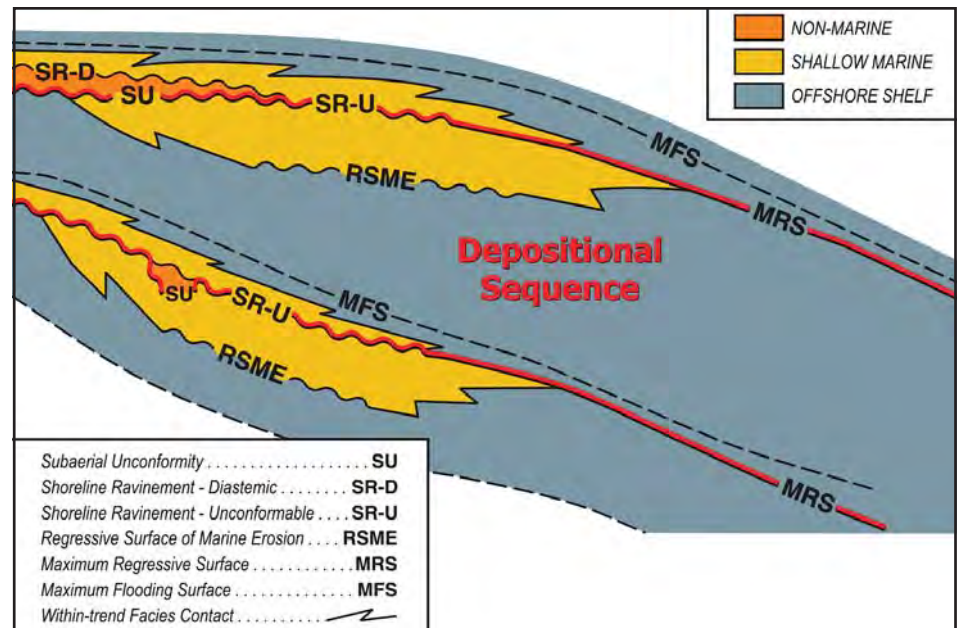

Figure 9.6. The boundaries of a material-based, depositional sequence are shown in red on this sequence model characterized by a ramp setting with a fast initial base-level rise rate. Due to the fast initial rise, the shoreline ravinement (SR-U) truncates the basinward portion of the subaerial unconformity (SU) and becomes a correlative surface. The basinward termination of the shoreline ravinement joins the landward termination of the maximum regressive surface (MRS). Thus a continuous, depositional sequence boundary consists of a SU, a SR-U, and a MRS.

ravinement does not truncate the basinward portion of the subaerial unconformity. The net result is that the SR and MRS are not correlative surfaces (i.e., do not join with) of the SU and, as illustrated on Figure 9.7, there are no correlative, material-based surfaces for an SU in such a model. The depositional sequence boundary is limited to the SU and cannot be extended farther basinward than the termination of the SU. Such a depositional sequence boundary is valid but of limited utility. Of interest, no convincing examples of such stratigraphic relationships have ever been well documented in the literature but there is no doubt that they are theoretically possible and likely await discovery.

Shelf / slope / basin setting – The sequence stratigraphic relationships for a sequence model with a shelf / slope / basin physiography are illustrated in Figure 9.8. The lower sequence boundary was generated under conditions of fast initial rise whereas the upper boundary represents slow initial base-level rise. For both boundaries, base level fell to the shelf edge such that a slope onlap surface (SOS) was generated. Notably, the key stratigraphic relationships are the same for both boundaries despite the difference in initial rise rate.

As illustrated on Figure 9.8, the defining subaerial unconformity (SU) is truncated basinward by the shoreline ravinement (SR-U). The SR-U then joins the SOS at the shelf edge and a maximum regressive surface, which occurs within the submarine fan deposits, onlaps the SOS. Thus the SR-U, SOS, and MRS are all correlative surfaces of the SU and, in combination, allow a depositional sequence boundary to be delineated from basin margin to the deep basin. Such a depositional sequence boundary (SU / SR-U / SOS / MRS) represents a modification of that proposed by Van Wagoner et al. (1988) which is illustrated in Figure 9.4A (page 41). The one change is that, within the basin, the MRS near the top of the submarine fan deposits, rather than the highly diachronous, facies change at the base of the submarine fan strata, is used as the correlative surface.

In shelf / slope / basin settings in which an SOS is not developed, a depositional sequence boundary is readily drawn along the SU / SR-U on the basin flank and along the correlative MRS which is developed on the outer shelf, slope and basin.

A sequence is best defined as a generic unit that is bound by a specific type of unconformity and its correlative surfaces. Two specific types of sequences have been recognized and defined so far – a genetic stratigraphic sequence (part MFS, defining unconformity) and a depositional sequence

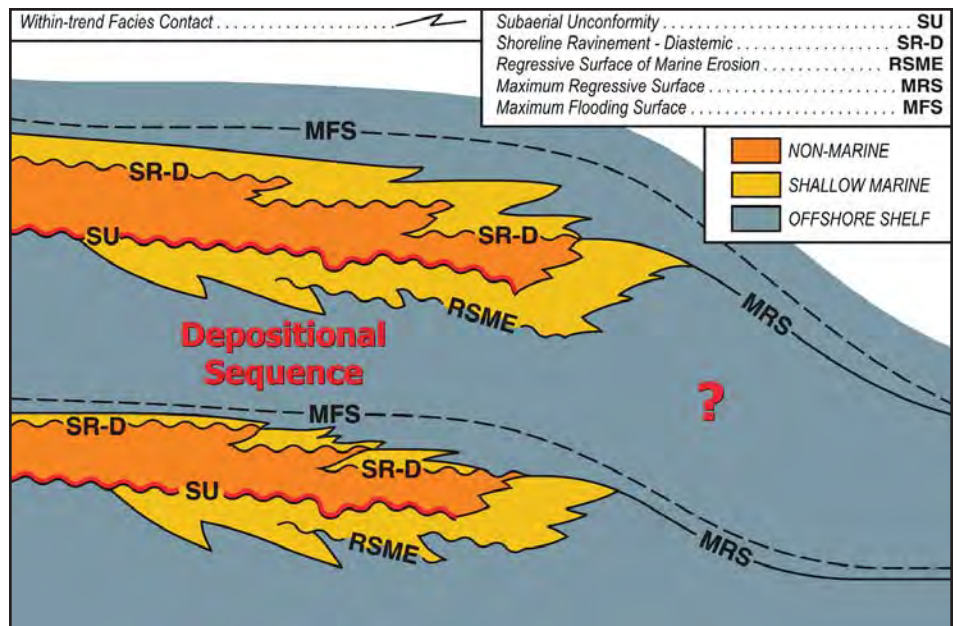

Figure 9.7. The boundaries of a material-based, depositional sequence are shown in red on this sequence model characterized by a ramp setting with a slow initial base-level rise rate. The boundaries consist only of the subaerial unconformities that are restricted to the basin flanks. There are no material-based, correlative surfaces, which would allow the sequence boundaries to be extended into the basin.

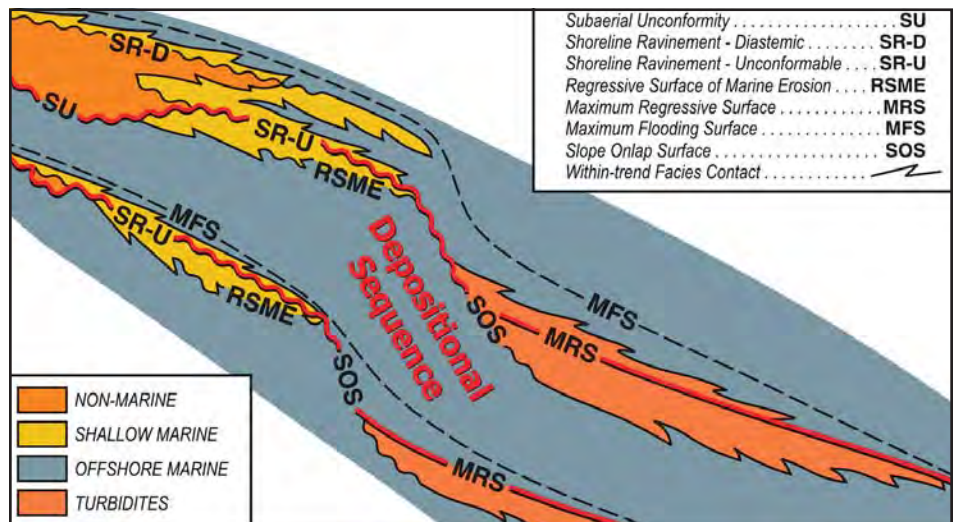

Figure 9.8. The boundaries of a material-based, depositional sequence are shown in red on this sequence model characterized by a shelf / slope / basin setting in which slope onlap surfaces (SOS) form. The correlative surfaces of the subaerial unconformity are an unconformable shoreline ravinement, a slope onlap surface, and a maximum regressive surface. This combination of surfaces forms a viable depositional sequence boundary that has great utility.

(SU, defining unconformity). The genetic stratigraphic sequence has the same boundaries for all sequence models and the bounding surfaces are always material-based. Numerous combinations of material-based and time-based surfaces have been proposed for a depositional sequence boundary.

For a material-based, depositional sequence boundary in a ramp setting, the only combination of surfaces which is valid and has widespread utility consists of a subaerial unconformity, an unconformable shoreline ravinement, and a maximum regressive

surface. A similar combination of surfaces, with or without the addition of a slope onlap surface, is valid and has great utility for a depositional sequence boundary for a shelf / slope / basin setting.

The next article will examine the time-based boundaries which have been proposed for a depositional sequence in both ramp and shelf / slope / basin settings.

References

Brown, L. and Fisher, W. 1977. Seismic-stratigraphic interpretation of depositional systems: Examples



- from the Brazilian rift and pull-apart basins. In: *Seismic stratigraphy: application to hydrocarbon exploration*. C. Payton, (ed.). American Association of Petroleum Geologists Memoir 26, p.213-248.
- Burchette, T. and Wright, V.P. 1992. Carbonate ramp depositional deposits. *Sedimentary Geology*, v. 79, p. 3-57.
- Embry, A. F. 2008a. *Practical Sequence Stratigraphy II: Historical Development of the Discipline: The First 200 Years (1788-1988)*. Canadian Society of Petroleum Geologists, *The Reservoir*, v. 35, issue 6, p. 35-40.
- Embry, A. F., 2008b. *Practical Sequence Stratigraphy III: Historical Development of the Discipline: The Last 20 Years (1988-2008)*. Canadian Society of Petroleum Geologists, *The Reservoir*, v. 35, issue 7, p. 24-29.
- Embry, A. F. 2009. *Practical Sequence Stratigraphy VIII: The Time-based Surfaces of Sequence Stratigraphy*. Canadian Society of Petroleum Geologists, *The Reservoir*, v. 36, issue 1, p. 27-33.
- Embry, A. F. In press. *Correlating Siliciclastic Successions with Sequence Stratigraphy*. In: *Application of Modern Stratigraphic Techniques: Theory and Case Histories*. K. Ratcliffe and B. Zaitlin (eds.). Society of Economic Paleontologists and Mineralogists, *Special Publication*.
- Embry, A., Johannessen, E., Owen, D, and Beauchamp, B. 2007. Recommendations for sequence stratigraphic surfaces and units (abstract). Arctic Conference Days, Abstract Book. Tromso, Norway.
- Galloway, W. 1989. Genetic stratigraphic sequences in basin analysis I: architecture and genesis of flooding surface bounded depositional units. *American Association of Petroleum Geologists Bulletin*, v. 73, p. 125-142.
- Jervey, M. 1988. Quantitative geological modeling of siliciclastic rock sequences and their seismic expression. In: *Sea level changes: an integrated approach*. C. Wilgus, B.S. Hastings, C.G. Kendall, H.W. Posamentier, C.A. Ross, and J.C. Van Wagoner, (eds.). Society of Economic Paleontologists and Mineralogists, *Special Publication* 42, p. 47-69.
- Johannessen, E. J. and Steel, R. J. 2005. Shelf-margin clinoforms and prediction of deep water sands. *Basin Research*, v. 17, p. 521-550.
- Mitchum, R., Vail, P., and Thompson, S. 1977. Seismic stratigraphy and global changes in sea level, part 2: the depositional sequence as the basic unit for stratigraphic analysis, In: *Seismic stratigraphy: application to hydrocarbon exploration*. Payton, C. (ed.). American Association of Petroleum Geologists Memoir 26, p. 53-62.
- Payton, C. (ed.). 1977. *Seismic stratigraphy: applications to hydrocarbon exploration*. American Association of Petroleum Geologists Memoir 26, 516 p.
- Sloss, L. 1963. Sequences in the cratonic interior of North America. *Geological Society of America Bulletin*, v. 74, p. 93-113.
- Sloss, L., Krumbein, W., and Dapples, E. 1949. Integrated facies analysis. In: *Sedimentary facies in geologic history*. Longwell, C. (ed.). Geological Society America, *Memoir* 39, p. 91-124.
- Vail, P. et al. 1977. Seismic stratigraphy and global changes in sea level. In: *Seismic stratigraphy: applications to hydrocarbon exploration*. Payton, C. (ed.). American Association of Petroleum Geologists Memoir 26, p. 49-212.
- Van Wagoner, J. C., Posamentier, H. W., Mitchum, R. M., Vail, P. R., Sarg, J. F., Loutit, T. S., and Hardenbol, J. 1988. An overview of the fundamentals of sequence stratigraphy and key definitions. In: *Sea level changes: an integrated approach*. C. Wilgus, B.S. Hastings, C.G. Kendall, H.W. Posamentier, C.A. Ross, and J.C. Van Wagoner, (eds.). Society of Economic Paleontologists and Mineralogists, *Special Publication* 42, p. 39-46.
- Wheeler, H.E. 1964. Base level, lithosphere surface and time stratigraphy. *Geological Society of America Bulletin*. v. 75, p. 599-610.

Practical Sequence Stratigraphy X

The Units of Sequence Stratigraphy,

Part 2: Time-based Depositional Sequences

by Ashton Embry

Introduction

As described in the last article on material-based sequences (Embry, 2009b), a sequence is best defined generically as “a stratigraphic unit bound by a specific type of unconformity and its correlative surfaces.” Two specific types of sequences have been defined in the literature – the genetic stratigraphic sequence of Galloway (1989) (part of a maximum flooding surface for defining unconformity) and the depositional sequence of Mitchum et al. (1977) and Van Wagoner et al. (1988) (subaerial unconformity for defining unconformity).

The boundaries of a genetic stratigraphic sequence are always material-based for all sequence models and consist of maximum flooding surfaces. However, proposed boundaries for a depositional sequence are much more diverse. The proposed, material-based boundaries were described and evaluated in the last article (Embry, 2009b). The proposed boundaries for a depositional sequence which include time-based surfaces as correlative surfaces are described and evaluated herein. These time-based, depositional sequences are somewhat controversial as to their validity and utility.

Time-based, Depositional Sequence Boundaries

In the time-based approach to sequence stratigraphy, two time-based surfaces are recognized as valid surfaces of sequence stratigraphy. These surfaces were introduced by Hunt and Tucker (1992) and are: 1) the basal surface of forced regression (BSFR), which equates to the time surface (depositional surface) at the start of base-level fall and 2) the correlative conformity (CC), which equates to the time surface (depositional surface) at the start of base-level rise. These time-based surfaces were discussed in detail in a previous article in this series (Embry, 2009a).

Employing the Correlative Conformity

One proposed, time-based, depositional sequence boundary uses the correlative conformity (CC) as a key correlative surface of a subaerial unconformity so as to extend the sequence boundary well into the basin (e.g., Hunt and Tucker, 1992; Helland-Hansen and Gjelberg, 1994). In a sequence model

with a ramp physiography and a fast, initial rise, the correlative conformity joins the basinward end of the shoreline ravinement (SR-U) which in turn truncates the subaerial unconformity (SU) as previously discussed (Figure 10.1, see also Figure 2 in Helland-Hansen and Gjelberg, 1994). Thus, the CC is an acceptable correlative surface of an SU in this model and such a depositional sequence boundary (SU/SR-U/CC) is theoretically valid.

Figure 10.2 (page 46) illustrates a time-based, depositional sequence boundary using a CC as a correlative surface for a sequence model with ramp physiography and a slow initial rise (see also Figure 1 in Helland-Hansen and Gjelberg, 1994). As was previously discussed in Embry (2009b), there are no material-based, correlative surfaces for the SU in such a model. However, in the time-based approach, the CC provides such a correlative surface because it adjoins the basinward termination of the SU as shown in Figure 10.2 (page 46). Once again, such a depositional sequence boundary (SU/CC) is theoretically valid.

In a shelf/slope basin model, the CC closely coincides with the MRS as was discussed in Embry (2009a). As illustrated in Figure 10.3 (page 46), a continuous boundary consisting of an SU, an SR-U, an SOS, and a CC can be delineated on such a sequence model. Thus, such a time-based, depositional sequence boundary would also be theoretically valid.

Although depositional sequence boundaries which employ a CC as a correlative surface are theoretically valid, the practical utility of such boundaries is debatable. The reason for this is that no published studies have demonstrated how a CC can be delineated and correlated in well exposed strata or on closely spaced well logs with abundant core (see Embry, 2009a for a detailed discussion). Unconstrained interpretations of a CC on seismic data have been offered (e.g., Catuneanu et al., in press) but these have not been corroborated by rock-based data and remain questionable. As discussed by Embry (2009a), such seismic reflectors, which are interpreted to encompass timebased CCs, may actually be harbouring material-

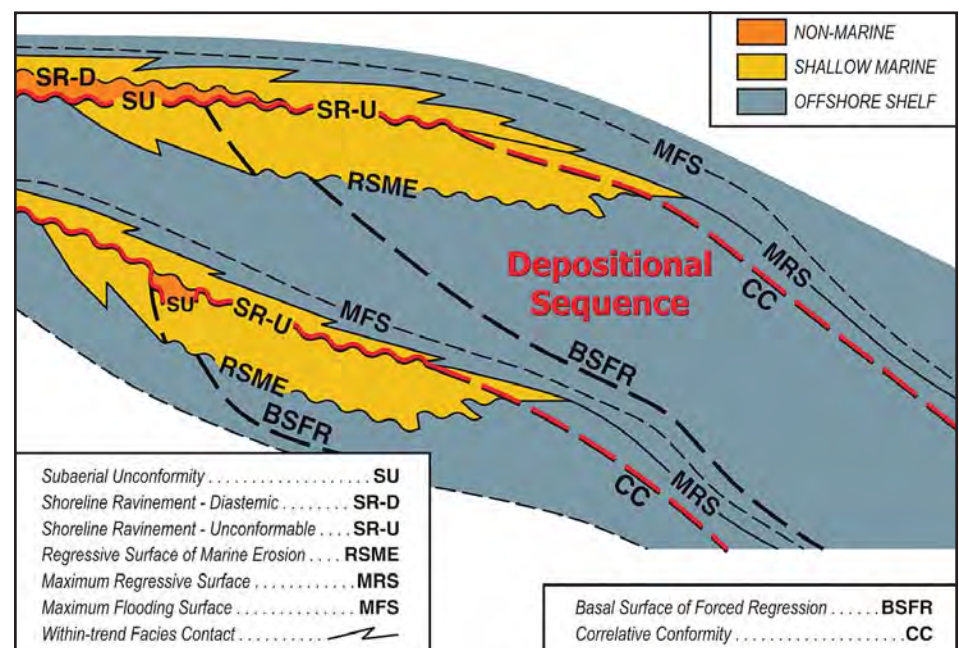

Figure 10.1. The boundaries of a time-based, depositional sequence are shown in red on this sequence model characterized by a ramp setting with a fast initial base-level rise rate. The correlative surfaces of the SU are the shoreline ravinement (SR-U) and the correlative conformity (time surface at start base-level rise).



based MRSs. Overall, much more research is necessary before a depositional sequence boundary which employs a CC can be accepted as having practical utility.

Employing the Basal Surface of Forced Regression

Another time-based depositional sequence boundary which has been proposed involves the use of the basal surface of forced regression as a correlative surface of an SU (Posamentier and Allen, 1999; Coe, 2003). This sequence boundary comprises the same combination of surfaces (SU/BSFR) for all sequence models. Such a depositional sequence boundary is shown for a ramp setting with a slow initial base-level rise (Figure 10.4).

Because the BSFR is developed long before the start of base-level rise, it intersects the SU landward of the basinward termination of the SU (Figure 10.4). It is also slightly offset by the regressive surface of marine erosion (RSME) if such a surface is developed. As was discussed by Embry (2009a), the BSFR has no physical characteristics making it of dubious value for comprising part of a sequence boundary. However, more importantly, the BSFR cannot be considered to be a valid correlative surface of an SU because it does not join with the end of the SU as shown in Figure 10.4. The use of such a sequence boundary results in much of the subaerial unconformity being inside the proposed sequence rather than on its boundaries (Figure 10.4), an inappropriate relationship for a depositional sequence. This would suggest that such a proposed depositional sequence boundary (SU/BSFR) be rejected as a possible option.

Summary

By defining a sequence as a generic unit which is bound by a specific type of unconformity and its correlative surfaces, two specific types of sequences are recognized – a depositional sequence (SU, defining unconformity) and genetic stratigraphic sequence (part MFS, defining unconformity). Numerous combinations of material-based and time-based surfaces have been proposed for a depositional sequence boundary.

In a time-based approach, a correlative conformity (CC) which represents a time surface (depositional surface) at the start of base-level rise is advocated for use as a correlative surface for extending the boundary well into the basin. Although the CC is a theoretically valid correlative surface, its use as part of a sequence boundary is compromised by a lack of physical characteristics that would allow a CC to be delineated and correlated with reasonable objectivity.

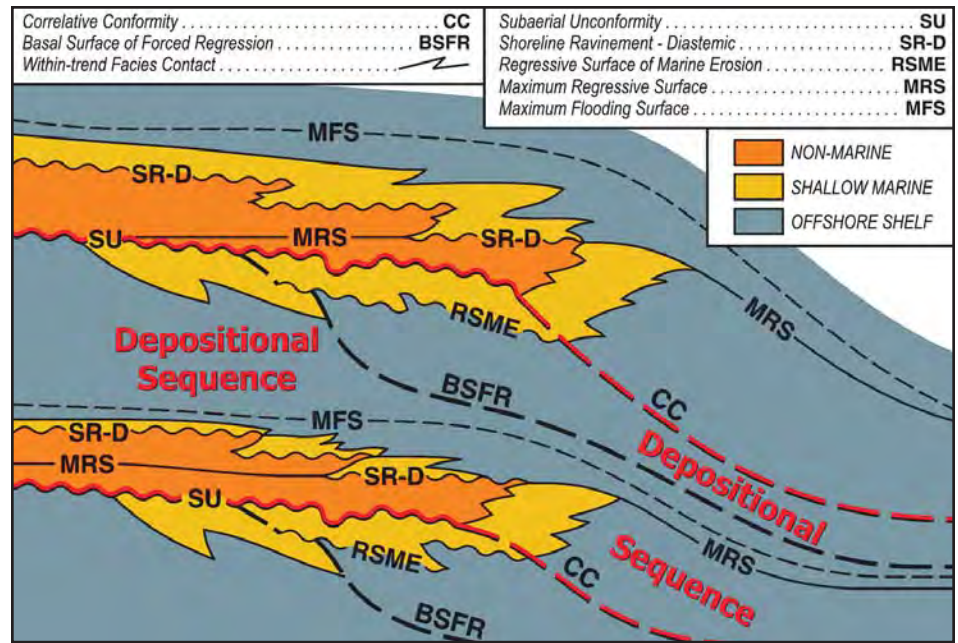

Figure 10.2 The boundaries of one proposed, time-based, depositional sequence are shown in red on this sequence model characterized by a ramp setting with a slow initial base-level rise rate. The correlative conformity (CC) is the only theoretically possible correlative surface of the subaerial unconformity for such a model. Unfortunately a CC has no physical characteristics which allow its delineation.

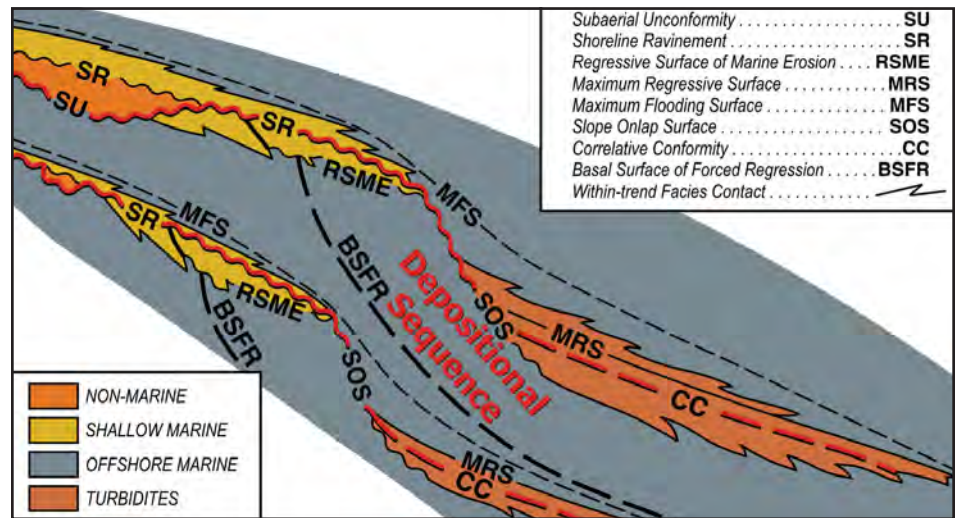

Figure 10.3. The boundaries of a time-based, depositional sequence are shown in red on this sequence model characterized by a shelf/slope/basin setting with a fast initial base-level rise rate. The correlative surfaces of the SU are the shoreline ravinement (SR-U), most of the slope onlap surface (SOS) and the correlative conformity (CC) (time surface at start base-level rise).

Another proposed, time-based, depositional sequence uses a basal surface of forced regression (time surface at start base-level fall) as a major part of the sequence boundary. The largest objection to such a proposal is that the BSFR is not a correlative surface of an SU because it is truncated by the SU far landward of the basinward termination of the SU. Such a proposed boundary is not compatible with the established definition of a depositional sequence.

The main proposed material-based and time-based sequence boundaries are summarized

in Figure 10.5 and most are for a depositional sequence boundary. The only boundaries which have widespread utility are material-based ones and include the MFS of the genetic stratigraphic sequence and the combined SU/SR-U/MRS, with or without an SOS, for the depositional sequence. All other proposed boundaries use an inappropriate correlative surface (e.g., BSFR, facies change) or include a correlative surface that cannot be recognized in most situations (e.g., CC).

The next article will examine systems tracts which are component stratigraphic units of



Figure 10.4. The boundaries of another proposal for a time-based, depositional sequence are shown in red on this sequence model characterized by a ramp setting with a slow initial base-level rise rate. In this case, the basal surface of forced regression (BSFR) (time surface at start base-level fall) is used as the primary correlative surface. Such a proposal is not reasonable because, as illustrated, the BSFR does not join the end of the subaerial unconformity.

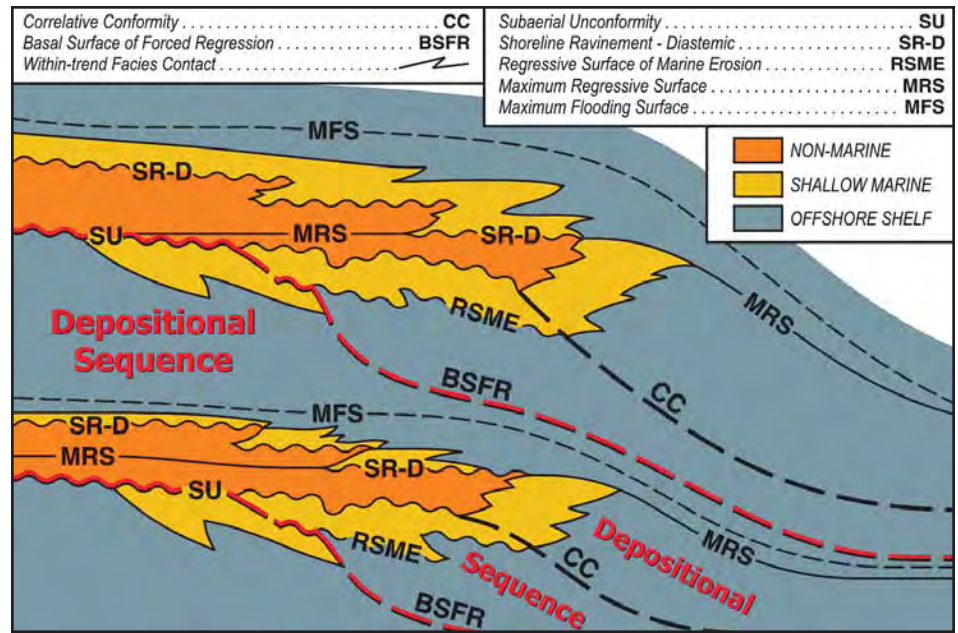

Figure 10.5. A summary of the various combinations of surfaces for the different types of sequence boundaries which have been proposed.

Approach	Sequence Model	Sequence Type	Surfaces Used For Sequence Boundary	Evaluation
Material-based	Shelf/Slope/Basin Slow Initial BL Rise Van Wagoner et al., 1988	Depositional Sequence	SU, SR-U, SOS, Base, Turbidites	Invalid Includes lithostratigraphic surface
	Shelf/Slope/Basin All Rates Initial BL Rise Embry, 2009a	Depositional Sequence	SU, SR-U, SOS, MRS	Valid Practical
	Ramp Fast Initial BL Rise Rate Embry, 1993	Depositional Sequence	SU, SR-U, MRS	Valid Practical
	Ramp Slow Initial BL Rise Rate Van Wagoner et al., 1988	Depositional Sequence	SU, Base, Shallow water unit	Invalid Includes lithostratigraphic surface
	Ramp Slow Initial BL Rise Rate Embry, 2009b	Depositional Sequence	SU	Valid Impractical - Limited extent
	All Models Galloway, 1989	Genetic Stratigraphic Sequence	MFS	Valid Practical
Time-based	All Models Posamentier and Allen, 1999	Depositional Sequence	SU, RSME, BSFR	Invalid BSFR is not a correlative surface
	Ramp Fast Initial BL Rise Rate Helland-Hansen and Gjelberg, 1994	Depositional Sequence	SU, SR-U, CC	Valid Impractical - CC is cryptic
	Ramp Slow Initial BL Rise Rate Helland-Hansen and Gjelberg, 1994	Depositional Sequence	SU, CC	Valid Impractical - CC is cryptic
	Shelf/Slope/Basin All Rates Initial BL Rise Hunt and Tucker, 1992	Depositional Sequence	SU, SOS, CC	Valid Impractical - CC is cryptic



a sequence. Once again, both material-based and time-based systems tracts have been defined. The main ones in each approach will be discussed and appraised as to their validity and utility for mapping and communication.

References

Catuneanu, O., et al., in press. Towards the Standardization of Sequence Stratigraphy. *Earth Science Reviews*.

Coe, A. (ed.). 2003. *The sedimentary record of sea-level change*. Cambridge University Press, New York, 287 p.

Embry, A.F. 1993. Transgressive-regressive (T-R) sequence analysis of the Jurassic succession of the Sverdrup Basin, Canadian Arctic Archipelago. *Canadian Journal of Earth Sciences*, v. 30, p. 301-320.

Embry, A.F. 2009a. Practical Sequence Stratigraphy VIII: The Time-based Surfaces of Sequence Stratigraphy. *Canadian Society of Petroleum Geologists, The Reservoir*, v. 36, issue 1, p. 27-33.

Embry, A.F. 2009b. Practical Sequence Stratigraphy IX: Part 1 Material-based Sequences. *Canadian Society of Petroleum Geologists, The Reservoir*, v. 36, issue 2, p. 23-29.

Galloway, W. 1989. Genetic stratigraphic sequences in basin analysis I: architecture and genesis of flooding surface bounded depositional units. *American Association of Petroleum Geologists Bulletin*, v. 73, p. 125-142.

Helland-Hansen, W. and Gjelberg, J., 1994, Conceptual basis and variability in sequence stratigraphy: a different perspective. *Sedimentary Geology*, v. 92, p. 1-52.

Hunt, D. and Tucker, M. 1992. Stranded parasequences and the forced regressive wedge systems tract: deposition during base-level fall. *Sedimentary Geology*, v. 81, p. 1-9.

Mitchum, R., Vail, P., and Thompson, S. 1977. Seismic stratigraphy and global changes in sea level, part 2: the depositional sequence as the basic unit for stratigraphic analysis. In: *Seismic stratigraphy: application to hydrocarbon exploration*. C. Payton, (ed.). American Association of Petroleum Geologists Memoir 26, p. 53-62.

Posamentier, H. and Allen, G. 1999. Siliciclastic sequence stratigraphy – concepts and applications. *Society of Economic Paleontologists and Mineralogists, Concepts in Sedimentology and Paleontology*, no. 7, 210 p.

Van Wagoner, J.C., Posamentier, H.W., Mitchum, R.M., Vail, P.R., Sarg, J.F., Loutit, T.S., and Hardenbol, J. 1988. An overview of the fundamentals of

sequence stratigraphy and key definitions, In: *Sea level changes: an integrated approach*. C. Wilgus, B.S. Hastings, C.G. Kendall, H.W. Posamentier, C.A. Ross, and J.C. Van Wagoner, (eds.). Society of Economic Paleontologists and Mineralogists, Special Publication 42, p. 39-46.



Practical Sequence Stratigraphy XI

The Units of Sequence Stratigraphy,

Part 3: Systems Tracts

by Ashton Embry

Introduction

The sequence is the primary unit of sequence stratigraphy and, as was discussed in the previous two articles (Embry, 2009a, b), two specific types of sequences have been defined. Both a depositional sequence and a genetic stratigraphic sequence can be subdivided into component units that are called systems tracts. Like a specific sequence type, a defined systems tract must be bound by specific, recognizable sequence stratigraphic surfaces if it is to have validity and utility.

Van Wagoner et al. (1988) and Posamentier and Vail (1988) advanced sequence stratigraphy with the innovation that a sequence can be subdivided into component units on the basis of sequence stratigraphic surfaces that occur within a sequence. This enhances mapping and communication and adds to the resolution capability of sequence stratigraphy. They referred to such component units of a sequence as systems tracts, a unit originally defined by Brown and Fisher (1977), as “a linkage of contemporaneous depositional systems”. Such a definition does not make clear what type of surfaces bound systems tracts. Furthermore, such a definition implies that systems tracts are chronostratigraphic units and have time surfaces and / or time barriers for boundaries. Van Wagoner et al. (1988, p. 39) adopted the Brown and Fisher (1977) definition and noted that systems tracts “are defined by their position within the sequence and by the stacking patterns of parasequence sets and parasequences”. This methodology also is somewhat problematic because sequence stratigraphic units are primarily defined by their bounding surfaces rather than internal properties such as “stacking patterns”.

A simpler and more straightforward definition is proposed for a systems tract. Embry et al. (2007) defined a systems tract as “a component unit of a sequence which is bound by sequence-stratigraphic surfaces”. Such a definition is generic, leaves no doubt as to a systems tract being a sequence stratigraphic unit, and allows specific types of systems tracts to be defined. The definition also honours the Brown and Fisher (1977) original definition and makes it clear that sequence stratigraphic surfaces rather than

time surfaces form the boundaries. It also is compatible with the Van Wagoner et al. (1988, 1990) usage in that various sequence stratigraphic surfaces are often delineated on the basis of a change in stacking pattern as discussed in previous articles in this series. Importantly, this definition also covers the common situation where stacking patterns are not evident. Finally, the proposed definition emphasizes the boundaries of the unit and it can be readily applied for subdividing any specific type of sequence including ones which may be proposed in the future.

Like other sequence stratigraphic units, a systems tract is defined by its bounding surfaces. A specific type of systems tract can be defined by key sequence stratigraphic surfaces and their correlative surfaces which form its lower and upper boundaries. It is emphasized that it is the bounding stratigraphic surfaces which define a given type of systems tract and not the characteristics of the strata within the systems tract. Of course, the characteristics of the strata, such as stacking patterns of smaller-scale units and grain-size trends in the strata, substantially contribute to the delineation of the various bounding surfaces and thus indirectly contribute to the delineation of a given systems tract.

Similar to sequence boundaries, the specific bounding surfaces that have been proposed for systems tracts include both material-based surfaces and time-based surfaces. This results in the existence of both material-based systems tracts, which have only material-based surfaces for boundaries, and time-based systems tracts, which have at least one time-based surface as a part of one or both of its boundaries. The two different approaches to systems tract definition are described below.

Material-based Systems Tracts

Two different, material-based systems tract classification schemes have been proposed. One defined three specific systems tracts for a depositional sequence and the other only two.

Three Systems Tracts: Van Wagoner et al. (1988) and Posamentier et al. (1988)

subdivided a depositional sequence into three specific systems tracts. As described in Part 9 of this series (Embry, 2009a), the defining boundary of a depositional sequence as proposed by these authors is a combination of a subaerial unconformity and an unconformable shoreline ravinement (SU / SR-U) on the shelf, a slope onlap surface (SOS) along the slope, and a facies change at the base of the turbidites in the basin. They defined three systems tracts within such a depositional sequence (Figure 11.1, page 50) on the basis of two sequence stratigraphic surfaces – a transgressive surface and a maximum flooding surface – within it. In current terminology, a “transgressive surface” is equivalent to a combined maximum regressive surface (MRS) and diastemic shoreline ravinement (SR-D).

The lowermost systems tract was called the lowstand systems tract (LST) and was bound at the base by the subaerial unconformity (SU) on the shelf and basinward by the slope onlap surface (SOS) and the facies change below the turbidites. The LST was bound at the top by the “transgressive surface” (SR-D + MRS) and it encompassed both marine strata and nonmarine strata. The middle systems tract was named the transgressive systems tract (TST) and it was bound by the transgressive surface (SR-D + MRS) below and the maximum flooding surface (MFS) above. The upper systems tract was called the highstand systems tract (HST) and it was bound by the MFS below and the sequence boundary (SU / SOS / facies change) above (Figure 11.1, page 50).

There are a few arguable issues associated with both the LST and the HST as defined and applied by Van Wagoner et al. (1988, 1990). The main one is that the highly diachronous facies change at the base of the turbidites is not a well defined bounding surface for either a sequence or a systems tract, as discussed in Embry (2009a). This facies change at the base of the turbidites is used as both the basal contact of the LST and the upper contact of the HST. As defined, part of the bounding surface of these systems tracts does not constitute a sequence stratigraphic surface. Furthermore, the use of a diastemic shoreline ravinement (landward portion of their “transgressive



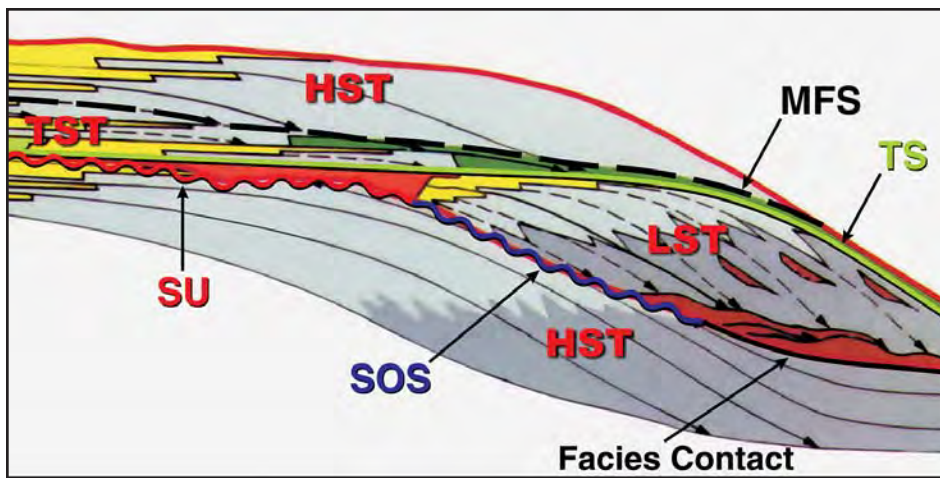

Figure 11.1. The Van Wagoner et al. (1988) depositional sequence boundary for a shelf / slope setting consists of a subaerial unconformity (SU) on the shelf, a slope onlap surface (SOS) on the slope, and the facies change at the base of the submarine fan deposits in the basin (modified from a portion of Figure 2 of Van Wagoner et al., 1988). Two surfaces are recognized within such a sequence – the transgressive surface (TS) and the maximum flooding surface (MFS) and allow the delineation of three systems tracts – lowstand (LST), transgressive (TST), and highstand (HST).

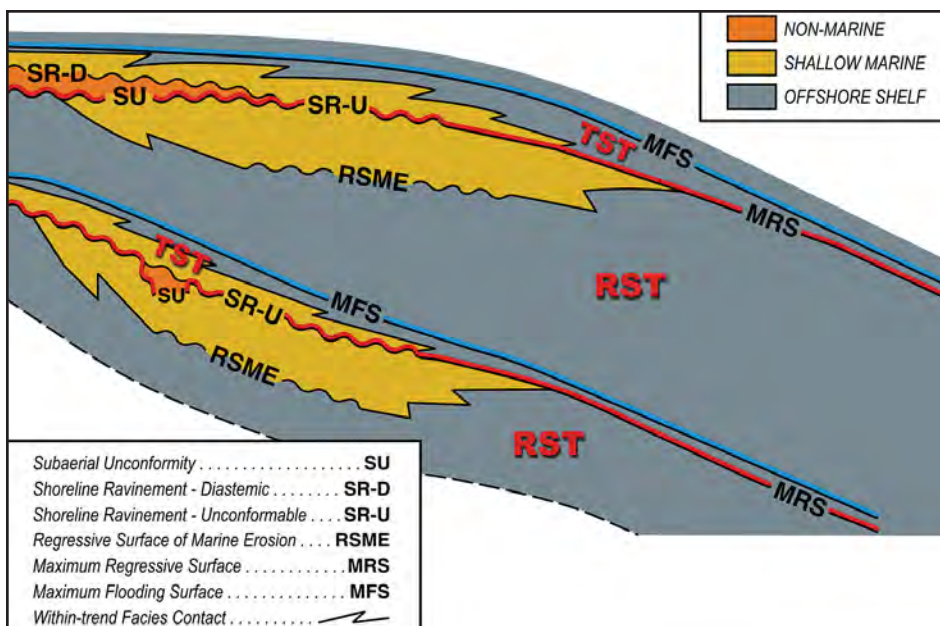

Figure 11.2. The boundaries of a material-based, depositional sequence (SU, SR-U, MRS) are shown in red on this sequence model characterized by a ramp setting with a fast initial base-level rise rate. The occurrence of the low diachroneity maximum flooding surface (MFS) allows the sequence to be subdivided into two systems tracts – a transgressive systems tract (TST) and a regressive systems tract (RST). Note that all nonmarine strata between the SU and the MFS are placed in the TST.

surface”) as the upper boundary of the LST on the basin flank is a problem because it is a highly diachronous surface.

Another issue involves the application of these three systems tracts to a ramp setting. The mutual boundary between the HST below and the LST above in a ramp setting equates to the sequence boundary. As discussed in Embry (2009a), Van Wagoner et al. (1988, 1990) and many others (e.g., Burchette and Wright, 1992) placed this boundary at a highly diachronous, facies

change at the base of a prograding shallow-water facies. Such a boundary is not definitive enough for either a systems tract or a sequence boundary.

Two Systems Tracts: Embry (1993) and Embry and Johannessen (1993) offered a solution to the problem of employing highly diachronous facies changes or a diastemic shoreline ravinement as systems tract boundaries. In ramp and shelf / slope / basin settings, the only material-based, low diachroneity, sequence stratigraphic surface

that occurs within a depositional sequence is the maximum flooding surface (MFS). On this basis, Embry (1993) proposed that a depositional sequence be subdivided into two systems tracts: a lower transgressive systems tract that follows the definition of Van Wagoner et al. (1988) and an upper, newly defined, regressive systems tract (Figures 11.2, 11.3).

These two systems tracts are best defined by the key sequence stratigraphic surfaces that form their lower and upper boundaries. Thus, a TST is defined as a sequence stratigraphic unit bound by correlative surfaces below and a maximum flooding surface and its correlative surfaces above. The RST is just the opposite being defined as a sequence stratigraphic unit bound by a maximum flooding surface and its correlative surfaces below and by a maximum regressive surface and its correlative surfaces above.

The RST, as defined above, includes both the LST and HST of Van Wagoner et al. (1988) and this is a consequence of eliminating a facies change surface (proposed HST / LST boundary) as a systems tract boundary (Figure 11.3). Also, the nonmarine strata assigned to an LST by Van Wagoner et al. (1988) (Figure 11.1) are much better placed in a TST (Figures 11.2, 11.3) as discussed by Suter et al. (1987) and many others.

The genetic stratigraphic sequence has MFSs as its bounding surfaces as discussed by Embry (2009a). Like the depositional sequence, it can also be subdivided into a TST and an RST by using the internal composite boundary of an SU / SR-U / SOS / MRS as a boundary for both systems tracts (Figures 11.2, 11.3).

In summary, two material-based systems tracts – transgressive systems tract and regressive systems tract – can be recognized in both a depositional sequence and a genetic stratigraphic sequence in almost all situations. Such recognition can be accomplished in a very objective manner.

Time-based Systems Tracts

As described in Embry (2009c), two abstract, time-based surfaces are recognized in the time-based approach to sequence stratigraphy. These are the basal surface of forced regression (BSFR) which equates to the time surface at the start of base-level fall and the correlative conformity (CC) which equates to the time surface at the start of base-level rise. The defined, time-based systems tracts use both material-based surfaces and the two abstract, time-based surfaces (BSFR, CC) as boundaries. Two classification systems of time-based systems tracts have been proposed – one defines four systems tracts for a depositional sequence

and the other three.

Four Systems Tracts: Hunt and Tucker (1992) proposed subdividing a depositional sequence into four systems tracts (Figure 11.4) that, in ascending order, were named lowstand, transgressive, highstand, and forced regressive systems tracts. The theoretical basis of this four systems tract classification scheme was elaborated upon by Helland-Hansen and Gjølberg (1994). The bounding surfaces for these units will differ slightly depending on the physiography of the setting (ramp or shelf / slope / basin) and the speed of the initial base-level rise (fast, slow). Thus, these different specific systems tracts are best defined by a key sequence stratigraphic surface that is common to all models and its correlative surfaces for both the lower and upper boundary. The four key surfaces that are used are used to define either the lower or upper boundary of the four systems tracts are two time-based surfaces – correlative conformity (CC) and basal surface of forced regression (BSFR) – and two material-based surfaces – maximum regressive surface (MRS) and maximum flooding surface (MFS). On this basis, the four systems tracts of Hunt and Tucker (1992) are defined below:

Lowstand Systems Tract (LST) – A component unit of a sequence defined by a correlative conformity (CC) and its correlative surfaces as the lower boundary and a maximum regressive surface (MRS) and its correlative surfaces as the upper boundary. This is a time-based systems tract.

Transgressive Systems Tract (TST) – A component unit of a sequence defined by a maximum regressive surface and its correlative surfaces as the lower boundary and a maximum flooding surface (MFS) and its correlative surfaces as the upper boundary. This is a material-based systems tract, which was originally defined by Van Wagoner et al. (1988).

Highstand Systems Tract (HST) – A component unit of a sequence defined by a maximum flooding surface and its correlative surfaces as the lower boundary and a basal surface of forced regression (BSFR) and its correlative surfaces as the upper boundary. This is a time-based systems tract.

Forced Regressive (Falling Stage) Systems Tract (FRST, FSST) – A component unit of a sequence defined by a basal surface of forced regression (BSFR) and its correlative surfaces as the lower boundary and a correlative conformity (CC) and its correlative surfaces as the upper boundary. This is a time-based systems tract.

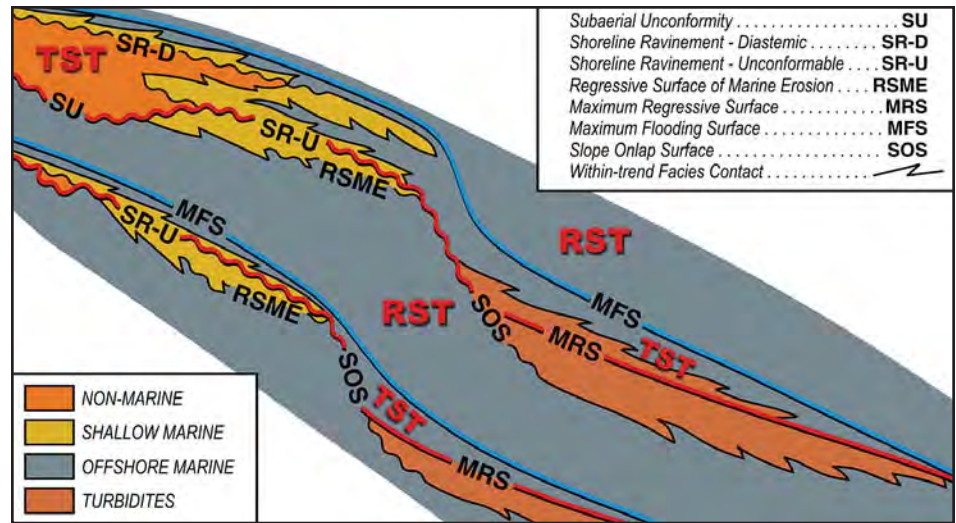

Figure 11.3. The boundaries of a material-based, depositional sequence (SU, SR-U, SOS, MRS) are shown in red on this sequence model characterized by a shelf / slope / basin setting. The internal maximum flooding surface allows such a sequence to be subdivided into a transgressive systems tract (TST) and a regressive systems tract.

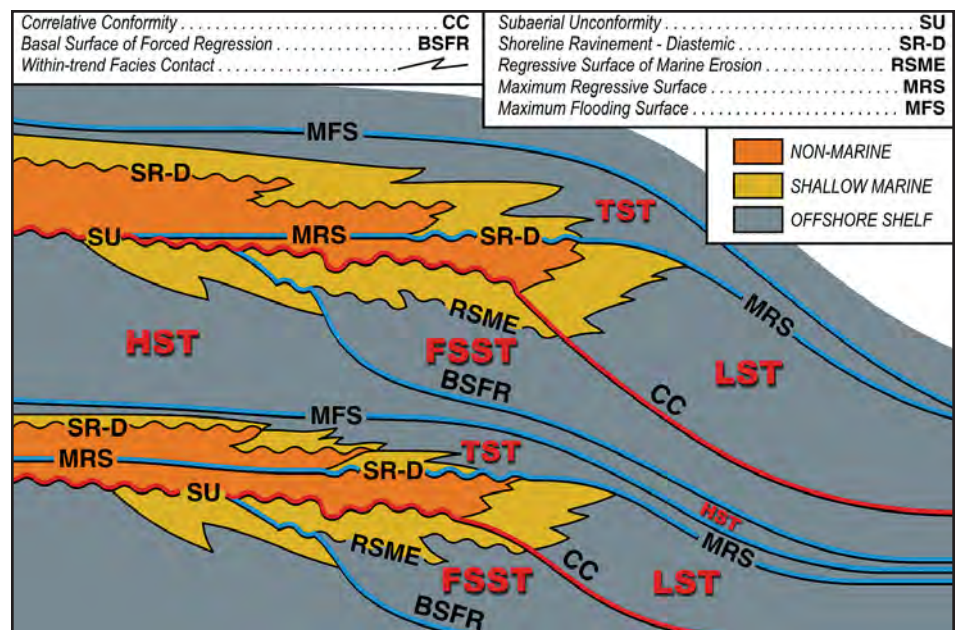

Figure 11.4. The boundaries of a time-based, depositional sequence (SU, CC) based on Hunt and Tucker (1992) are shown in red on this sequence model characterized by a ramp setting with a slow initial base-level rise rate. Such a sequence contains three sequence stratigraphic surfaces within it – maximum regressive surface (MRS), maximum flooding surface (MFS), and basal surface of forced regression (BSFR). This allows the time-based sequence to be subdivided into four systems tracts: three time-based ones (highstand (HST), falling stage (FSST), and lowstand (LST)) and one material-based one (transgressive (TST)).

In summary, the Hunt and Tucker (1992) classification scheme included three time-based systems tracts (LST, HST, and FRST) of their definition and one material-based systems tract (TST), which had originally been defined by Van Wagoner et al. (1988). Figure 4 illustrates these four systems tracts for a sequence model with a ramp setting and a slow initial base-level rise. Figure 11.5 (page 52) is a model with ramp setting and a fast initial rise. Note that the key, defining surfaces for the four systems tracts remain

the same in both models but in some cases the correlative surfaces are different. The same comment would apply if models with a shelf / slope / basin setting were illustrated.

In the Hunt and Tucker (1992) classification scheme, all the defined systems tracts, with the exception of the TST, utilize one or both of the two time surfaces (CC, BSFR) as part of their boundaries (Figure 11.4). As discussed in Embry (2009c), these time surfaces have no characteristic physical



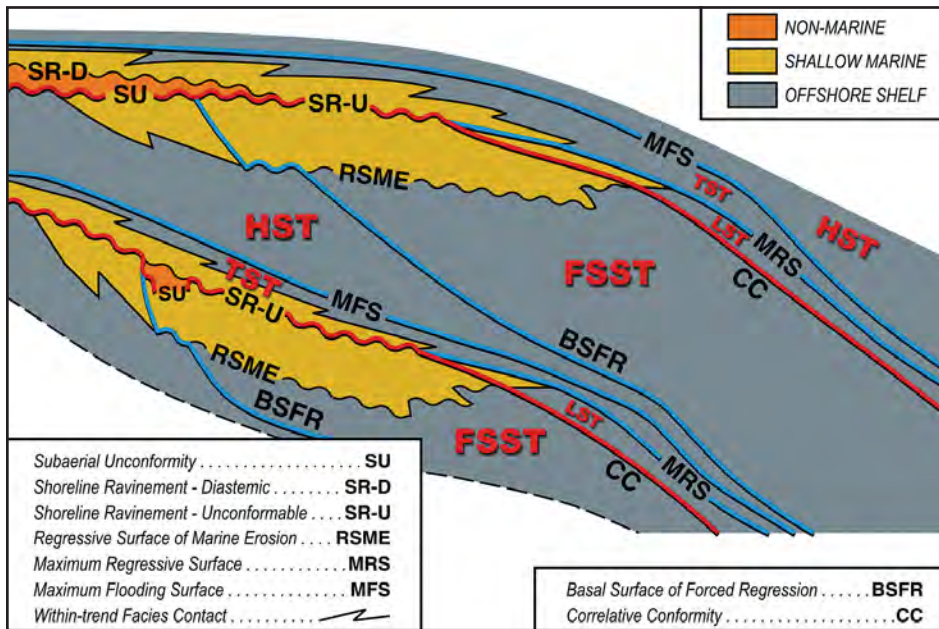

Figure 11.5. The boundaries of a time-based, depositional sequence (SU, SR-U, CC) based on Hunt and Tucker (1992) are shown in red on this sequence model characterized by a ramp setting with a fast initial base-level rise rate. The same four systems tracts with the same key, defining surfaces as shown on Figure 4 can be delineated. Note that the correlative surfaces of the key surfaces differ from those shown in Figure 4. For example the correlative surfaces of the CC in this figure are the SU and SR-U whereas in Figure 4 the only correlative surface of the CC is the SU.

properties and thus cannot be delineated objectively in most settings. The use of such boundaries is potentially problematic. Thus, I would not recommend the LST, HST, and FRST (FSST) as defined by Hunt and Tucker (1992) for use in sequence stratigraphy.

Three Systems Tracts: The second, time-based systems tract classification scheme is that of Posamentier and Allen (1999). As described in the previous article on time-based sequences (Embry, 2009b), Posamentier and Allen (1999) placed the correlative surface for the depositional sequence boundary along the basal surface of forced regression (BSFR) which is the time surface at the start of base-level fall. They divided such a depositional sequence into three systems tracts: lowstand, transgressive, and highstand (Figure 11.6).

The transgressive systems tract and highstand systems tract of this classification follow the definitions used by Hunt and Tucker (1992) in that they have exactly the same key surfaces defining their lower and upper boundaries. Only the lowstand systems tract has a new and different definition and it contrasts with the two previous definitions of an LST provided by Van Wagoner et al. (1988) and Hunt and Tucker (1992).

Posamentier and Allen (1999) defined a lowstand systems tract as being bound at its base by the basal surface of forced regression and its correlative surfaces and at its top by

the maximum regressive surface and its correlative surfaces (Figure 11.6). Note that Posamentier and Allen (1999) do not use the correlative conformity as a systems tract boundary. However, they do suggest that their lowstand systems tract might be

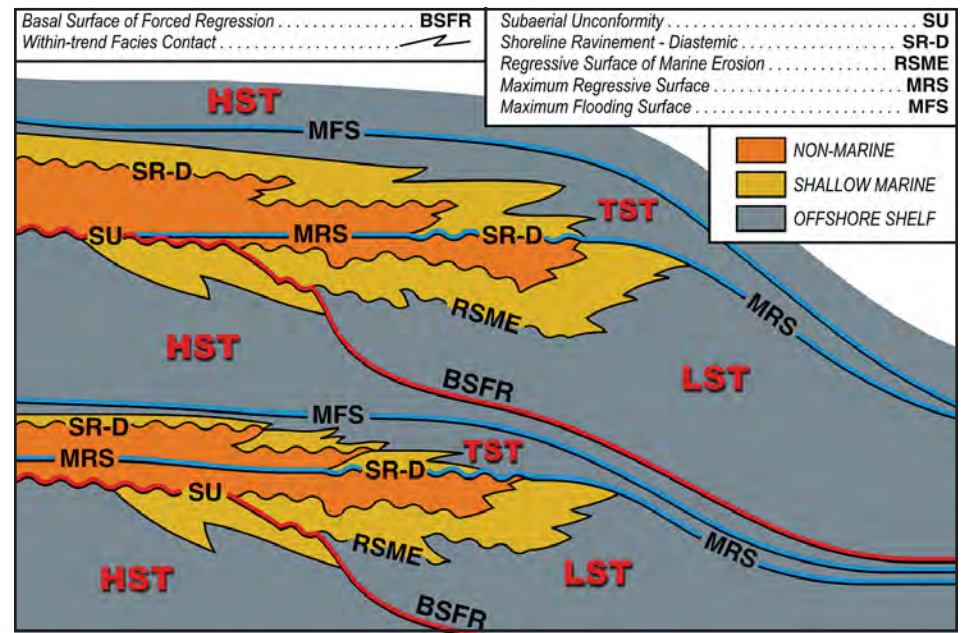

Figure 11.6. The boundaries of the Posamentier and Allen's (1999) proposed time-based, depositional sequence (SU, BSFR) are shown in red on this sequence model characterized by a ramp setting with a slow initial base-level rise rate. Only two internal surfaces, MRS and MFS, are recognized and accordingly Posamentier and Allen (1999) subdivided their depositional sequence into three systems tracts – lowstand (LST), transgressive (TST), and highstand (HST). The TST and HST followed the original definitions of these units but the LST was redefined by making the BSFR as the key bounding surface at its base.

subdivided into an “early LST” and a “late LST” by recognition of the CC within an LST.

As was discussed in the previous section, the highstand systems tract as defined by Hunt and Tucker (1992) and adopted by Posamentier and Allen (1999) has limited use in practice because it is bound in part by an abstract time surface (BSFR) with no physical characteristics. The same comment applies to Posamentier and Allen's (1999) revised definition of a lowstand systems tract that has the abstract BSFR as the key surface for its lower boundary.

In summary, two classification schemes have been proposed in the time-based approach to sequence stratigraphy. Both schemes contain one material-based systems tract, the TST, which is valid and of practical value. Two different, time-based definitions for a lowstand systems tract, which was originally defined as a material-based unit, have been proposed. Both use an abstract time surface as part of the lower boundary (BSFR for one and CC for the other), which limits their practical applications. The other specific systems tracts proposed in these schemes (HST, FRST) are also bound in part by an abstract time surface that limits their use.

Summary

A systems tract is best defined as a component unit of a sequence which is bound by sequence stratigraphic surfaces. Specific systems tracts are defined by key surfaces

Approach	Material-Based		Time-Based		Interpreted Events		
	Sequence Model	Exxon 1988 All Models Van Wagoner et al., 1988	All Models Embry, 1993	All Models Helland-Hansen and Gjelberg, 1994		All Models Posamentier and Allen, 1999	
Systems Tracts	MFS	HST	MFS	RST	MFS	HST	Start Regression
	MRS	TST	MRS	TST	MRS	TST	
		LST	RST	CC	LST	Late	Start Base Level Rise
	FACIES CHANGE			FRST (FSST)		Early	
	MFS	HST	MFS	HST	BSFR	BSFR	Start Base Level Fall
	MRS	TST	MRS	TST	MFS	HST	Start Regression
		LST	RST	CC	LST	Late	Start Base Level Rise
	FACIES CHANGE			FRST (FSST)		Early	
	MFS	HST	MFS	HST	BSFR	BSFR	Start Base Level Fall

Figure 11.7. A summary of the various systems tract classification schemes that have been proposed. The sequence boundaries are in red and internal systems tract boundaries are in blue.

and their correlative surfaces for both the lower and upper boundaries of the unit. For example, a transgressive systems tract is defined as a sequence stratigraphic unit bound at its base by a maximum regressive surface and its correlative surfaces and at its top by a maximum flooding surface and its correlative surfaces.

Four different classification schemes for subdividing a depositional sequence into systems tracts have been proposed – two material-based schemes and two time-based schemes. These four proposals are summarized and compared in Figure 11.7. In the material-based approach to sequence stratigraphy, the three systems tract classification scheme of Van Wagoner et al. (1988) is problematic because the LST and HST use a highly diachronous facies change as a key surface for both of these units. The elimination of the facies change as a bounding surface and the combination of the HST and LST into a single systems tract, which is termed a regressive systems tract (RST) (Embry, 1993), results in a more practical, two systems tract classification scheme (Figure 11.7).

In the time-based approach to sequence stratigraphy, both a four systems tract classification scheme and a three systems tract one have been proposed. Both

classification schemes are problematic in that most of the defined systems tracts have limited practical value due to the use of an abstract time surface as one or both of bounding surfaces of the unit.

The most useful systems tracts which have been proposed so far are the transgressive systems tract and the regressive systems tract. The most confusing and contentious unit is the lowstand systems tract in that it has been defined in three different ways.

References

Brown, L. and Fisher, W. 1977. Seismic stratigraphic interpretation of depositional systems: Examples from the Brazilian rift and pull-apart basins. In: *Seismic stratigraphy: application to hydrocarbon exploration*. C. Payton (ed.). AAPG Memoir 26, p. 213-248.

Burchette, T. and Wright, V. P. 1992. Carbonate ramp depositional deposits. *Sedimentary Geology*, v. 79, p. 3-57.

Embry, A. F., 1993, *Transgressive-regressive (T-R) sequence analysis of the Jurassic succession of the Sverdrup Basin, Canadian Arctic Archipelago*. *Canadian Journal of Earth Sciences*, v. 30, p. 301-320.

Embry, A. F. 2009a. *Practical sequence stratigraphy IX: the units of sequence*

stratigraphy; part 1, material-based sequences. *Canadian Society of Petroleum Geologists. The Reservoir*, v. 36, issue 2, p. 23-29.

Embry, A. F. 2009b. *Practical sequence stratigraphy X: the units of sequence stratigraphy; part 2, time-based sequences*. *Canadian Society of Petroleum Geologists. The Reservoir*, v. 36, issue 3, p. 21-24.

Embry, A. F. 2009c. *Practical sequence stratigraphy VIII: the time-based surfaces of sequence stratigraphy*. *Canadian Society of Petroleum Geologists. The Reservoir*, v. 36, issue 1, p. 27-33.

Embry, A. F. and Johannessen, E. P. 1993. T-R sequence stratigraphy, facies analysis and reservoir distribution in the uppermost Triassic-Lower Jurassic succession, western Sverdrup Basin, Arctic Canada, In: *Arctic Geology and Petroleum Potential*. T. Vorren, E. Bergsager, O.A. Dahl-Stamnes, E. Holter, B. Johansen, E. Lie, and T.B. Lund (eds.). NPF Special Publication 2, p. 121-146.

Embry, A., Johannessen, E. P., Owen, D., and Beauchamp, B., 2007. Recommendations for sequence stratigraphic surfaces and units (abstract). *Arctic Conference Days, Abstract Book*. Tromso, Norway.

Helland-Hansen, W. and Gjelberg, J. 1994. *Conceptual basis and variability in sequence*



stratigraphy: a different perspective. *Sedimentary Geology*, v. 92, p. 1-52.

Hunt, D. and Tucker, M. 1992. Stranded parasequences and the forced regressive wedge systems tract: deposition during base-level fall. *Sedimentary Geology*, v. 81, p. 1-9.

Posamentier, H. and Vail, P. 1988. Eustatic controls on clastic deposition II - sequence and systems tract models. In: *Sea level changes: an integrated approach*. C. Wilgus, B. S. Hastings, C. G. Kendall, H.W. Posamentier, C.A. Ross, and J. C. Van Wagoner, (eds.). *Society of Economic Paleontologists and Mineralogists, Special Publication 42*, p. 125- 154.

Posamentier, H. Jervey, M. and Vail, P., 1988. Eustatic controls on clastic deposition I-conceptual framework. In: *Sea level changes: an integrated approach*. C. Wilgus, B. S. Hastings, C. G. Kendall, H.W. Posamentier, C.A. Ross, and J. C. Van Wagoner, (eds.). *Society of Economic Paleontologists and Mineralogists, Special Publication 42*, p. 109- 124.

Posamentier, H. and Allen, G. 1999. Siliciclastic sequence stratigraphy – concepts and applications. *Society of Economic Paleontologists and Mineralogists, Concepts in Sedimentology and Paleontology*, no. 7, 210 p.

Suter, J., Berryhill, H., and Penland, S. 1987. Late Quaternary sea level fluctuations and depositional sequences, southwest Louisiana continental shelf. In: D. Nummedal, O. Pilkey, and J. Howard (eds.). *Sea-level changes and coastal evolution*. *Society of Economic Paleontologists and Mineralogists, Special Publication 41*, p. 199-122.

Van Wagoner, J. C., Posamentier, H. W., Mitchum, R. M., Vail, P. R., Sarg, J. F., Loutit, T. S., and Hardenbol, J. 1988. An overview of the fundamentals of sequence stratigraphy and key definitions. In: *Sea level changes: an integrated approach*. C. Wilgus, B. S. Hastings, C. G. Kendall, H.W. Posamentier, C. A. Ross, and J. C. Van Wagoner, (eds.). *Society of Economic Paleontologists and Mineralogists, Special Publication 42*, p. 39-46.

Van Wagoner, J. C., Mitchum, R. M., Campion, K. M., and Rahmanian, V. D. 1990. Siliciclastic sequence stratigraphy in well logs, cores and outcrops. *American Association of Petroleum Geologists, Methods in Exploration*, no. 7, 55 p.

Practical Sequence Stratigraphy XII

The Units of Sequence Stratigraphy, Part 4: Parasequences

by Ashton Embry

Introduction

There are three basic types of stratigraphic units in use in sequence stratigraphy – sequence, systems tract, and parasequence. Various proposals for defining and delineating specific types of sequences and systems tracts were reviewed and discussed in the last three articles in this series (Embry, 2009a, b, c). In this article I will discuss the last unit type – the parasequence.

Original Definition

The term parasequence was originally defined by Van Wagoner et al. (1988, p. 39). In keeping with sequence stratigraphic practice, they defined a parasequence by means of its bounding surfaces: “a relatively conformable succession of beds or bedsets bound by marine-flooding surfaces.” To understand the definition of a parasequence, one needs a definition of its defining bounding surface – a marine-flooding surface.

A marine-flooding surface, which is much more commonly called a flooding surface (FS), was defined by Van Wagoner et al. (1988, p. 39) as “a surface separating younger from older strata across which there is an abrupt increase in water depth.” This definition does not provide much insight into what a flooding surface actually is and how one would recognize one. All stratigraphic surfaces separate younger from older strata (Law of Superposition) leaving “an abrupt increase in water depth” as the only criteria for recognition. Given this is a very interpretive criteria, rather than an observable one, it is not a suitable characteristic for defining a material-based surface. Because adequate definitions were not provided, one is left wondering what a flooding surface actually is and, consequently, what a parasequence is.

Van Wagoner et al. (1990) provided much more information and insight into what they actually meant by the terms flooding surface and parasequence, although the actual definitions remained the same as those originally offered. They provided a model for the development of a parasequence (Van Wagoner et al., 1990, Figure 4) (Figure 12.1 herein) and portrayed parasequences as units of shallowing-upward strata separated by surfaces which marked a transgression. As

shown on Figure 12.1, Van Wagoner et al. (1990) did not include the formation of any transgressive strata in their parasequence model. Given the Law of the Conservation of Matter, this lack of any transgressive strata is nonactualistic as discussed by Arnott (1995).

Consideration of this aspect of the model helps to put in context problems associated with the Van Wagoner et al. (1988, 1990) concept of a flooding surface and a parasequence. These are discussed below.

Parasequence as a Lithostratigraphic Unit

An inspection of various diagrams in Van Wagoner et al. (1990) (e.g., Figures 3b and 7 in Van Wagoner et al., 1990) reveals that what Van Wagoner et al. (1988, 1990) meant by a flooding surface is a contact between a marine sandstone below and a deeper-water, marine shale / siltstone above (Figure 12.2). Going by the illustrations in Van Wagoner et al.

(1990), such a contact can be gradational (conformable) or scoured (diastem). As shown on Figures 12.2 and 12.3, a flooding surface, as conceived and applied by Van Wagoner et al. (1988, 1990), is best categorized as a within-trend facies contact that is developed within a transgressive succession. A flooding surface (FS) lies

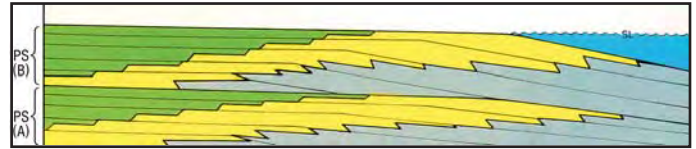

Figure 12.1. The Van Wagoner et al. (1990) model for parasequences. Each parasequence consists of a succession of coarsening-upward, regressive strata. The lack of any transgressive strata is a problematic flaw in this model. Modified after a portion of Van Wagoner et al. (1990), Figure 4.

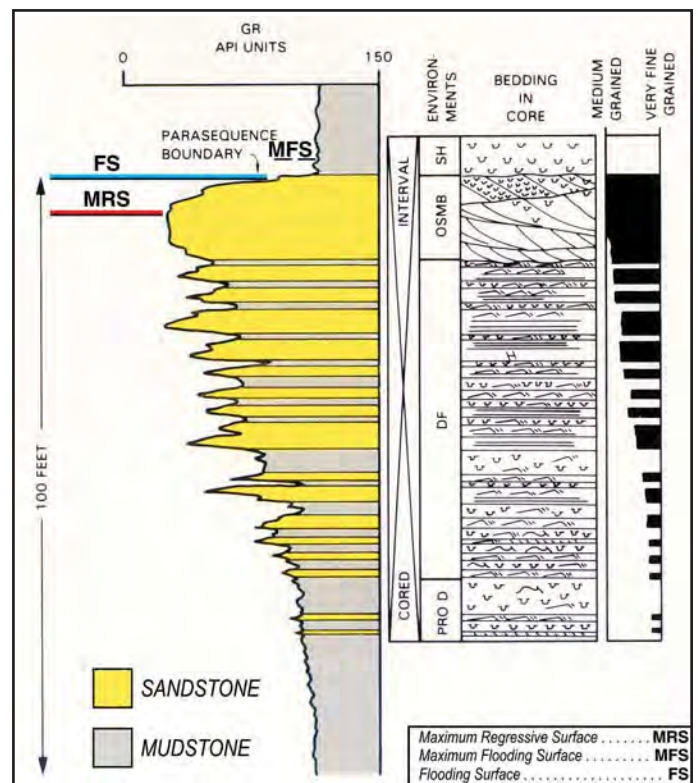

Figure 12.2. Parasequence boundary as defined and illustrated by Van Wagoner et al. (1988, 1990). These authors placed the boundary at the change from sandstone below to shale / siltstone above and called such a surface a flooding surface (FS). As shown, a flooding surface (FS) lies between a maximum regressive surface (MRS) below and a maximum flooding surface (MFS) above. As defined, a flooding surface is a lithostratigraphic surface rather than a sequence stratigraphic one. Modified after a portion of Van Wagoner et al. Figure 3B.

between two surfaces of sequence stratigraphy – a maximum regressive surface (MRS) below and a maximum flooding surface (MFS) above (Figures 12.2 and 12.3). Notably, a flooding surface does not represent a change in depositional trend. Rather, it represents a change in lithology (sandstone / limestone to shale / marl) within a



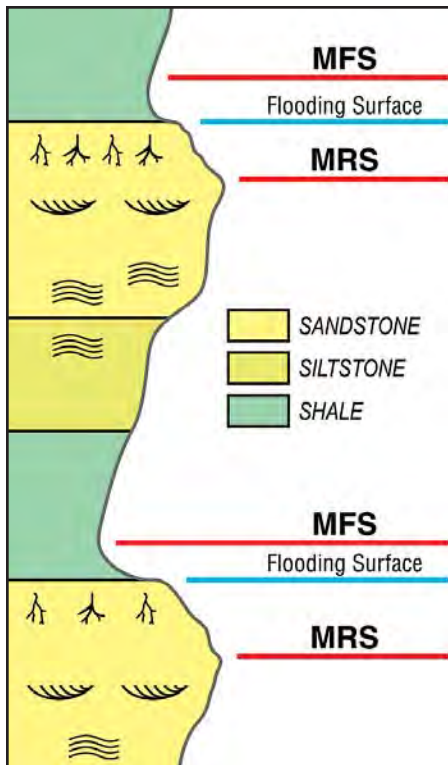

Figure 12.3. A schematic section of a transgressive-regressive succession that is not interrupted by any unconformities. Two sequence stratigraphic surfaces, maximum regressive surface (MRS) and maximum flooding surface (MFS) as well as a lithostratigraphic surface, flooding surface (FS), can be delineated in such a succession.

Although Van Wagoner et al. (1988, 1990) put the parasequence boundary at the flooding surface, others have used the MRS or the MFS. Such variance in boundary delineation has resulted in considerable confusion regarding the placement of a parasequence boundary.

depositional trend (e.g., within a fining-upward succession) and consequently is best considered to be a lithostratigraphic surface rather than a sequence stratigraphic one.

With the understanding of what a flooding surface really is, it follows that a parasequence is a unit bound by lithostratigraphic surfaces. Furthermore, this means that a parasequence as defined and used by Van Wagoner et al. (1988, 1990) is really a lithostratigraphic unit and not a sequence stratigraphic one. Another complication is that the term flooding surface has also been sometimes inappropriately applied to well defined and characterized, material-based surfaces of sequence stratigraphy including a maximum regressive surface, a maximum flooding surface, and a shoreline ravinement (Embry, 2005; Catuneanu, 2006). This practice has created additional uncertainty and confusion as to what a flooding surface and a parasequence

really are and how they can be objectively delineated. Additional confusion has resulted from cases where an MFS coincides with the lithological change from sandstone to shale.

Redefining a Parasequence as a Sequence Stratigraphic Unit

The parasequence is a widely used unit in sequence stratigraphic analysis despite uncertainties concerning boundary placement and consequent variations in use. To rectify this confusing situation, it is

necessary to define a parasequence using bona fide sequence stratigraphic surfaces for its defining boundaries. The schematic cross section of Figure 12.4 illustrates two different placements for a parasequence boundary. Van Wagoner et al. (1988, 1990) put the boundary at the diachronous, facies change from sandstone to shale (flooding surface) whereas, I would contend a better placement is at the maximum regressive surface (MRS), which is a sequence stratigraphic surface with very low

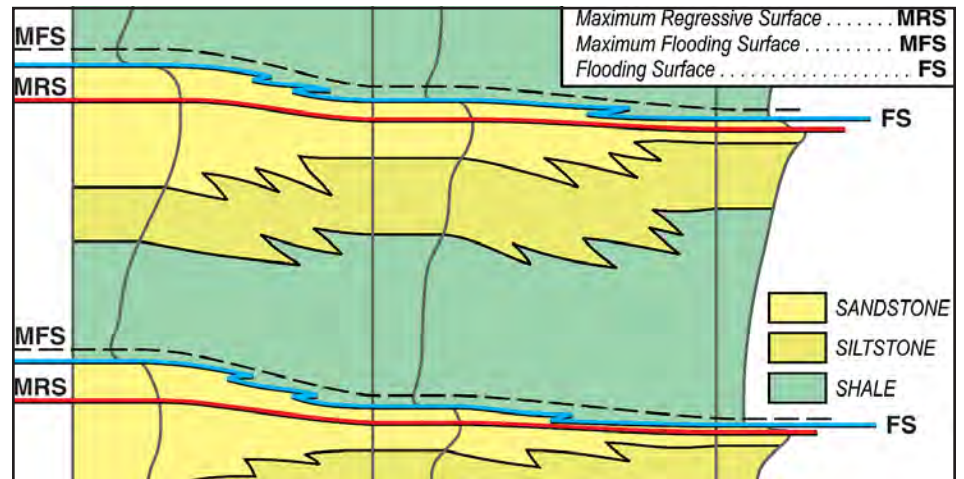

Figure 12.4. A schematic cross-section showing the correlation of three transgressive-regressive successions. Van Wagoner et al. (1988, 1990) recommend the use of the diachronous, flooding surface (FS), a lithostratigraphic surface, as the boundary for a parasequence. Herein, the maximum regressive surface (MRS) which has very low diachroneity and is a sequence stratigraphic surface, is recommended as the defining bounding surface for a parasequence. A unit bound by maximum flooding surfaces (MFS) has already been defined and named a genetic stratigraphic sequence.



Figure 12.5. The upper portion of a small scale, regressive-transgressive succession is shown. A maximum regressive surface (MRS) is delineated at the base of the red weathering, massive, highly burrowed, calcareous sandstone unit and coincides with the change from a coarsening- and shallowing-upward succession (regressive) to a fining- and deepening-upward succession (transgressive). A flooding surface (FS) occurs within the transgressive strata at the boundary between the burrowed sandstone and the overlying unit of shale and siltstone. Middle Devonian Bird Fiord Formation, Bathurst Island.



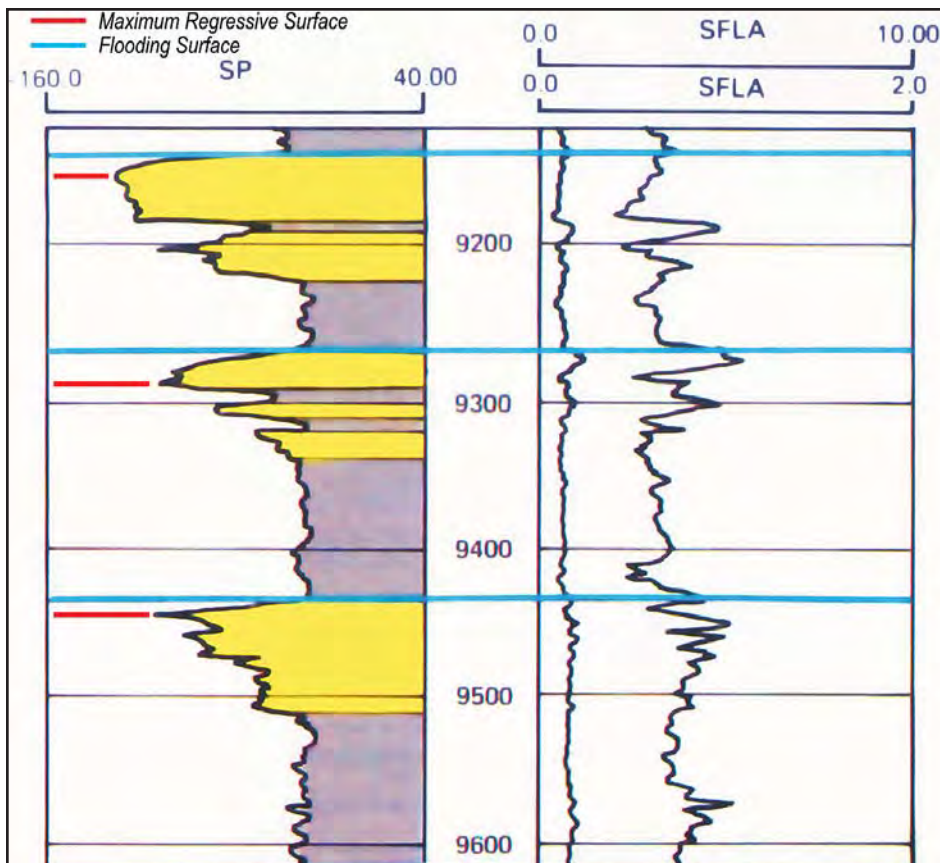

Figure 12.6. A portion of Figure 7 of Van Wagoner et al. (1990) showing the Van Wagoner et al. (1990) parasequence boundaries (FSs in blue) versus the recommended MRSs in red. Modified after a portion of Van Wagoner et al. (1990) Figure 7.

diachroneity. As shown in Figures 12.5 and 12.6, the MRS occurs below an FS. Figure 12.7 illustrates an outcropping parasequence which has MRSs for boundaries. The highly burrowed, massive sandstone that was deposited during transgression and deepening is placed at the base of the parasequence rather than at the top as proposed by Van Wagoner et al. (1988, 1990). Arnott (1995) also reached the same conclusion that a parasequence boundary is best placed at the base of such transgressive strata.

I suggest a parasequence be defined as “a small-scale, sequence stratigraphic unit bound by maximum regressive surfaces (MRS) and their correlative surfaces”. Because an MRS is an accepted, material-based surface of sequence stratigraphy (Embry, 2002, 2008), this change ensures that a parasequence is a bona fide sequence stratigraphic unit. Furthermore, such a definition does not alter the basic meaning or utility of a parasequence and matches how numerous practitioners have already applied the term (e.g., Arnott, 1995).

Parasequence vs. Sequence

As shown on Figure 12.8 (page 60), a parasequence is delineated and extended by recognizing MRSs and correlating them.

Sometimes a maximum flooding surface (MFS) can replace an MRS and in this situation the MFS would act as the parasequence boundary because it would be a correlative surface of the MRS. If both bounding MRSs

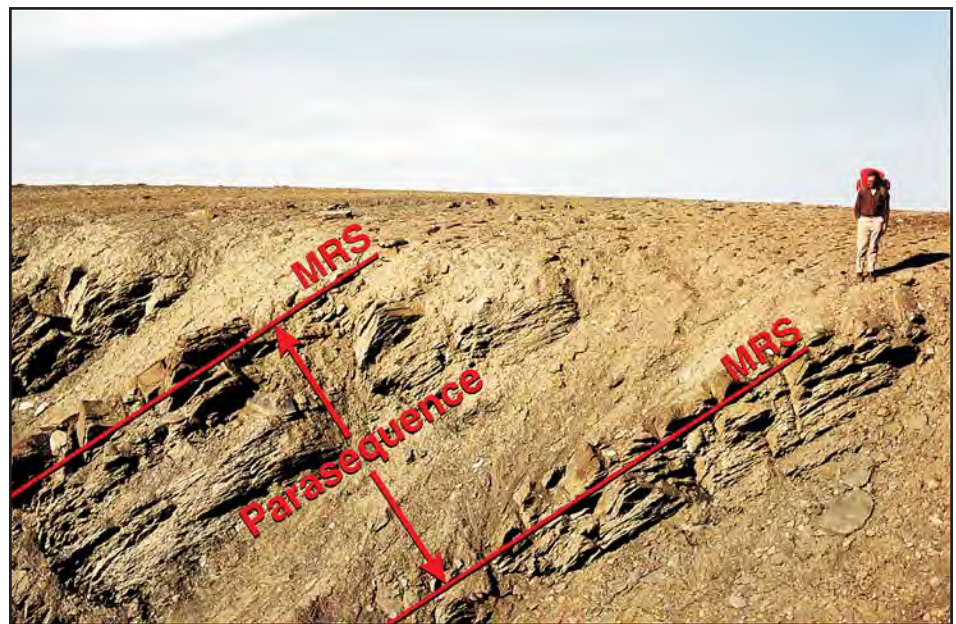

Figure 12.7. A parasequence is delineated in outcropping Bird Fiord Formation (Middle Devonian) strata on Bathurst Island, Canadian Arctic Archipelago. The boundaries are placed at readily recognizable maximum regressive surfaces (MRS). Tom Oliver for scale.

were everywhere replaced by MFSs, the resultant unit would be a genetic stratigraphic sequence (Embry, 2009a) rather than a parasequence.

An MRS often correlates with an unconformable shoreline ravinement (SRU) on the basin flanks and thus an SR-U can act as one of the bounding surfaces of a parasequence. However, when both bounding MRSs of a previously delineated parasequence can be shown to be correlative with SR-Us (Figure 12.9, page 60), then the unit must be designated as a depositional sequence rather than a parasequence. Thus a parasequence can be seen as a “depositional sequence in waiting” and any parasequence which has been recognized is potentially a depositional sequence upon subsequent work and extended correlation.

Given the above, a case can be made for dropping the term parasequence all together and including a unit bounded by MRSs within the definition of a depositional sequence. Hopefully, this question will be decided over the next few years.

Parasequence and Scale

Part of the proposed definition of a parasequence limits the term parasequence to small-scale units (< tens-of-metres thick) and this is dictated by current practice. Large-scale (hundreds-of-metres thick) sequence stratigraphic units bound by MRSs are best designated as depositional sequences. The reason for this is almost all larger magnitude MRSs correlate back to unconformities (SR-Us, SUs) on the basin margin.



Final remarks

The term parasequence is best applied exclusively to small-scale, transgressive regressive units bound by MRSs and their correlative surfaces. Parasequences are formed either during a small-scale, base-level fall-rise cycle (correlative SR-U not yet recognized) or during a reduction in sediment supply during base-level rise (no

SR-U generated). Finally, I recommend that that a flooding surface (a lithostratigraphic surface between a marine sandstone / limestone below and a shaly lithology above) be allowed as a proxy for a parasequence boundary when available data do not allow the MRS to be reliably or easily delineated. However, I would emphasize that it is desirable to use MRSs whenever possible.

References

Arnott, R.W. 1995. The parasequence definition – are transgressive deposits inadequately addressed? *Journal of Sedimentary Research*, v. 65, p. 1-6.

Catuneanu, O. 2006. *Principles of Sequence Stratigraphy*. Elsevier, New York, 375 p.

Embry, A. F. 2002. Transgressive-Regressive (T-R) Sequence Stratigraphy, In: *Sequence stratigraphic models for exploration and production*. J. Armentrout and N. Rosen (eds.). *Gulf Coast Society of Economic Paleontologists and Mineralogists Conference Proceedings*, Houston, p. 151-172.

Embry, A. F. 2005. Parasequences in Third Generation (3G) Sequence Stratigraphy. *Search and Discovery Article #110022*. <http://www.searchanddiscovery.net/documents/2005/av/embry/softvnetplayer.htm>.

Embry, A. F. 2008. *Practical Sequence Stratigraphy VI: The Material-based Surfaces of Sequence Stratigraphy, Part 2: Shoreline ravinement and Maximum Regressive Surface*. *Canadian Society of Petroleum Geologists. The Reservoir*, v. 35, issue 9, p. 32-39.

Embry, A. F. 2009a. *Practical Sequence Stratigraphy IX: The Units of Sequence Stratigraphy, Part 1, Material-based Sequences*. *Canadian Society of Petroleum Geologists. The Reservoir*, v. 36, issue 2, p. 23-29.

Embry, A. F. 2009b. *Practical Sequence Stratigraphy X: The Units of Sequence Stratigraphy, Part 2, Time-based Sequences*. *Canadian Society of Petroleum Geologists. The Reservoir*, v. 36, issue 3, p. 21-24.

Embry, A. F. 2009c. *Practical Sequence Stratigraphy XI: The Units of Sequence Stratigraphy, Part 3: Systems Tracts*. *Canadian Society of Petroleum Geologists. The Reservoir*, v. 36, issue 4, p. 24-29.

Van Wagoner, J. C., Posamentier, H.W., Mitchum, R. M., Vail, P.R., Sarg, J. F., Loutit, T. S., and Hardenbol, J. 1988. An overview of the fundamentals of sequence stratigraphy and key definitions. In: *Sea level changes: an integrated approach*. C. Wilgus, B. S. Hastings, C. G. Kendall, H.W. Posamentier, C. A. Ross, and J. C. Van Wagoner (eds.). *Society of Economic Paleontologists and Mineralogists, Special Publication 42*, p. 39-46.

Van Wagoner, J. C., Mitchum, R. M., Campion, K. M., and Rahmanian, V. D. 1990. Siliciclastic sequence stratigraphy in well logs, cores and outcrops. *American Association of Petroleum Geologists. Methods in Exploration*, no. 7, 55 p.

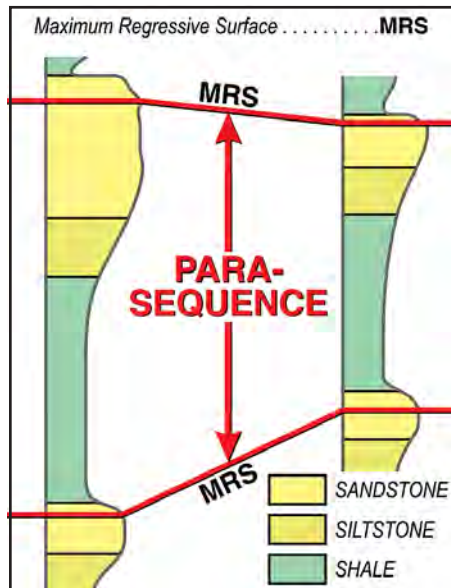

Figure 12.8. As shown on this schematic cross-section, parasequences are delineated and correlated on the basis of maximum regressive surfaces (MRS). Correlative surfaces of an MRS often include a maximum flooding surface and a shoreline ravinement and these sequence stratigraphic surfaces can also be used as a parasequence boundary.

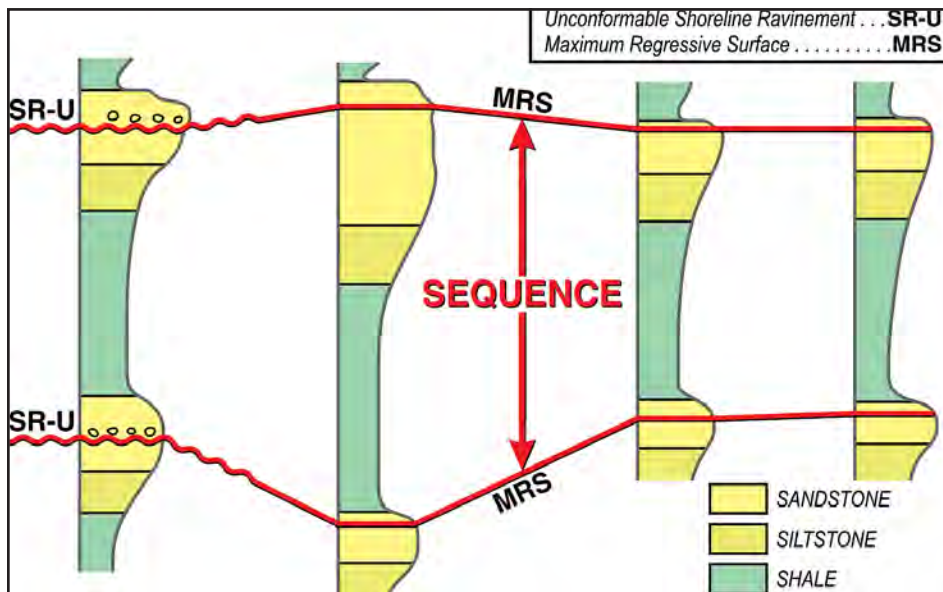

Figure 12.9. When both maximum regressive surface (MRS) boundaries of a previous delineated parasequence (e.g., see Figure 8) are found to correlate with unconformable shoreline ravinements (SR-U), as illustrated on this schematic cross-section, the unit becomes a depositional sequence. Thus a parasequence can be regarded as a “depositional sequence in waiting.”

Practical Sequence Stratigraphy XIII

Sequence Stratigraphy Hierarchy

by Ashton Embry

Introduction

The various surfaces and units of sequence stratigraphy have been described in the previous articles of this series. It is most important that sequence stratigraphic surfaces be assigned to a hierarchy if numerous sequence stratigraphic surfaces are used for regional correlation or if individual sequences are delineated and mapped (Embry, 1993, 1995). The main reason for this is that very many sequence stratigraphic surfaces of greatly varying magnitude occur in a given succession and, without a hierarchy, any two recognized sequence boundaries, regardless of their magnitude, (e.g., two MFSs in the case of genetic stratigraphic sequences and any combination of two SU, SR-U, or MRSs in the case of a depositional sequence) could, in theory, be used to form the boundaries of a sequence (Figure 13.1). This would result in a huge number of potential sequences and the only way to escape such chaos is to establish a hierarchy of surfaces.

It is widely recognized that there is a great variation in the magnitude of sequence stratigraphic surfaces and that there is a need to separate large magnitude sequences / sequence boundaries from much smaller-scale ones. This is a natural consequence of the recognition that sequence boundaries and the enclosed sequences are not scale dependent. Notably, two very different methodologies for developing such a hierarchy of sequences and sequence boundaries have been proposed – a theoretical, model-driven method and an empirical, data-driven method.

Model-driven Hierarchy

The model-driven approach has been championed by Exxon scientists (e.g., Vail et al., 1977; Mitchum and Van Wagoner, 1991; Vail et al., 1991; Posamentier and Allen, 1999). Such an approach is based on the hypothesis that sequence stratigraphic surfaces are generated by eustasy-driven, sinusoidal base-level changes and that such eustatic cycles increase in amplitude with decreasing frequency. Thus, very large amplitude changes, driven by tectono-eustasy (changes in volume of ocean basins), occur rarely and the resulting sequence boundaries are assigned to either a 1st or 2nd order category. Such orders are usually referred to as low-order boundaries although a few authors refer to such boundaries as high-order boundaries. I

follow the practice of referring to 1st, 2nd and 3rd order boundaries as low-order boundaries and 4th, 5th and 6th order boundaries as high-order boundaries.

In the model-driven hierarchy, high-order boundaries are related to climate-driven, Milankovitch cycles, which drive high

frequency, eustatic changes in the 20,000 year to 400,000 year band. In such a model-driven approach, a sequence is assigned to a given order based on the amount of time represented by the sequence – that is, the amount of time which lapsed between the development of each of its bounding surfaces.

This model-driven approach culminated in a publication by Vail et al. (1991) in which six orders of boundaries were defined solely on boundary frequency. The six orders and their characteristic boundary frequencies in this hierarchical scheme are:

- 1st order – >50 MA
- 2nd order – 3-50 MA
- 3rd order – 0.5-3 MA
- 4th order – 0.08-0.5 MA
- 5th order – 0.03-0.08 MA
- 6th order – 0.01-0.03 MA

Such a model-driven approach to establishing a hierarchy of sequences is highly prone to circular reasoning. Because any given stratigraphic section contains numerous depositional sequence boundaries (unconformities and MRSs), any desired frequency of boundary occurrence can be determined simply by selecting only the boundaries that fit the desired result. For example, if fourteen sequence boundaries were recognized within a succession spanning 20 MA, there are many combinations of boundaries that could be chosen to delineate a sequence with a boundary frequency of 10 MA (Figure 13.2a, page 60). As shown in Figure 2b, Haq et al. (1988) applied such a methodology for the delineation of 2nd order cycles on their global sequence charts. The boundaries of the second order cycles (sequences) on the charts have been subjectively selected to fit the desired result (sequence duration of ~ 10 MA).

The fundamental flaw of the above, model-driven methodology is that you can't determine the frequency of occurrence of an entity or a phenomenon until you have a clear definition of the entity or phenomenon. It simply comes down to the premise that, if one wants to determine the frequency of 2nd order sequence boundaries, one must be able to empirically recognize 2nd order boundaries in the first place. Boundary frequency is a conclusion that can be only be reached once the different orders of boundaries are defined with reasonable

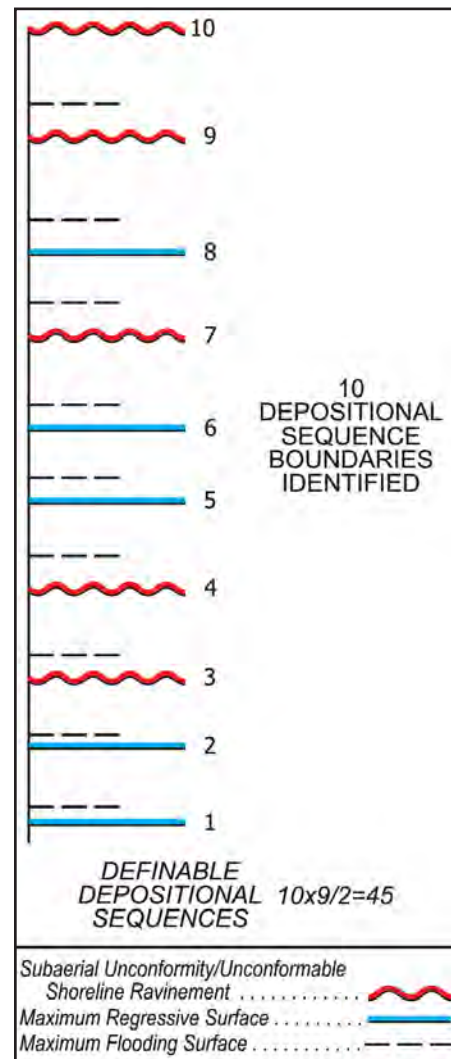

Figure 13.1. Because a depositional sequence is defined as a unit bound by subaerial unconformities and correlative surfaces, it is essential that a hierarchy of sequence boundaries be defined. If a hierarchical system is not used, up to 45 sequences could be defined in the above schematic succession with 10 recognized sequence boundaries (e.g., 1-2 1-3, 1-4, 1-5, etc.). Such a chaotic and unacceptable situation is avoidable only by separating the sequence boundaries into different classes (orders) and arranging them into a hierarchy.



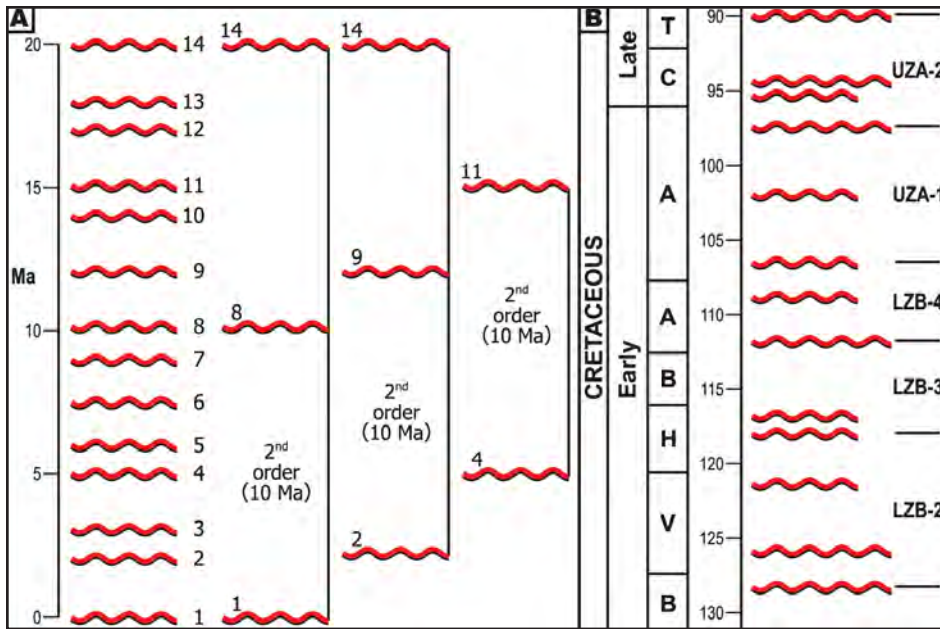

Figure 13.2a. A schematic diagram illustrating the faulty logic of using boundary frequency for the establishment of a sequence hierarchy. In a succession which spans 20 Ma and contains 14 sequence boundaries, many combinations of boundaries (only three shown) can be used to create second-order sequences with a 10 MA year frequency.

Figure 13.2b. A diagram from Haq et al. (1988) that illustrates the use of the concept of boundary frequency to define a series of second-order sequences (LZB-2, etc.). The boundaries of the second-order sequences have been subjectively selected to fit the desired result (sequences of 10 Ma duration).

objectivity. Duration is not an observable characteristic of a sequence.

Data-driven Hierarchy

Embry (1993, 1995) advocated for the use of an empirical, data-driven methodology for establishing a hierarchy of sequence stratigraphic boundaries and enclosed units. Such an approach is based on reasonably objective scientific criteria rather than on a priori assumptions and untested hypotheses, as is the case for the model-driven approach described above.

In the data-driven approach, a hierarchy of boundaries is established on the basis of the interpreted relative magnitude of the boundaries. The interpreted relative magnitude of a boundary would reflect the magnitude of base-level shift that generated the boundary in the first place. A base-level change of 500 m is going to result in a relatively large magnitude sequence boundary that has different attributes than a smaller magnitude sequence boundary that was generated by a base-level change of 10 m or less. In a given basin, the largest magnitude boundaries (i.e., the sequence boundaries generated by the largest interpreted base-level changes) are assigned to the 1st order category in the hierarchy and the smallest magnitude boundaries recognized (i.e., those generated by the smallest interpreted base-level changes) would be assigned to the highest order established (e.g., 4, 5, or 6).

To apply such a methodology, it is necessary to find observable, scientific criteria which allow the characterization of the relative magnitude of a sequence boundary. Such criteria would reflect the magnitude of the base-level change which generated the boundaries. The attributes of a sequence boundary I have found useful to estimate the relative magnitude of a sequence boundary, and indirectly the amount of base-level change that generated the boundary in the first place, are listed below. Such observable characteristics are placed in order of their importance for assessing the relative magnitude of a given depositional sequence boundary with the first one being most important.

- 1) The degree of change of the tectonic setting across the boundary.
- 2) The degree of change of the depositional regime and sediment composition across the boundary.
- 3) The amount of section missing below the unconformity at as many localities as possible. Localities close to the basin edge are very helpful.
- 4) The estimated amount of deepening at the maximum flooding surface above the sequence boundary where it is an unconformity.
- 5) How far the subaerial unconformity and associated shoreline facies penetrate into the basin.

It is important to note that not all these characteristics can be applied for each boundary, but in many cases most of them can be. In many instances, the largest magnitude boundaries in a basin, which would be 1st order boundaries for that basin, mark a significant change in tectonic and sedimentary regime and are associated with large amounts of erosion and significant deepening. The unconformity and shoreline facies usually penetrate far into the basin. Such sequence boundaries are most often readily apparent and correlatable and would bound 1st order depositional sequences. Because of the tectonic and sedimentary regime changes, there is little doubt that such boundaries were generated by tectonics (Figure 13.3) and denote very large, base-level changes both within the basin and in the surrounding hinterlands.

2nd order boundaries also mark a change in the tectonic and depositional regimes, as well as large changes in base level. Similar to 1st order boundaries, they are mainly driven by tectonics as evidenced by the tectonic regime change across the boundary. Evidence of tectonic movements including faulting, folding, and tilting can often be discerned beneath 1st and 2nd order boundaries. 2nd order boundaries differ from 1st order ones in that the amount of base-level change is distinctly less as evidenced by less erosion and basinward penetration of the unconformities. Also the magnitude of tectonic regime change is significantly less. The separation of 1st order boundaries from 2nd order ones can be somewhat subjective, but in most instances the two orders can be consistently differentiated from each other within a basin.

3rd order boundaries exhibit no tectonic regime change but do have a noticeable change in sedimentary regime across them. Once again it is likely that tectonics is the main driver of 3rd order boundaries because it is very difficult to explain the noticeable change in sedimentary regime on the basis of eustasy. The amount of erosion and basin penetration of the unconformable portions of 3rd order boundaries, as well as the subsequent deepening during the following transgression, are less than that for 1st and 2nd order boundaries (Figure 13.3). Notably 1st, 2nd, and 3rd order boundaries can usually be correlated throughout most or all of a basin and are the main ones recognized on seismic sections.

Sequence boundaries which exhibit no change in tectonic or depositional regime, are associated with little erosion and subsequent drowning, and the unconformity and shoreline facies do not extend past the basin margin, would be high-order, low-



magnitude boundaries (e.g., 4th, 5th, and 6th order) (Figure 13.3). Parasequence boundaries would constitute the highest order, lowest magnitude boundaries in the hierarchy and they reflect little to no base-level change. Correlation of these high-order boundaries is usually limited to local areas with widespread correlation being possible only if control points are close and numerous (e.g., WCSB).

For sequence boundaries generated during “Greenhouse” conditions (i.e., no continental glaciers), there tends to be a consistency for each of the five criteria to point to the same result in regards to assignment of an order to boundaries. In these cases, the magnitude of the boundary correlates closely with the basinward extent the unconformity, with the amount of section eroded and with the amount of subsequent deepening. Those large magnitude boundaries in which the unconformity extends far into the basin and for which significant erosion and subsequent drowning are present almost always have a significant change in depositional regime, if not also tectonic regime.

Problems with assignment sometimes occur for sequence boundaries formed during “Icehouse” conditions when continental glaciers were intermittently present. During such times, relatively large base-level changes (up to ~ 120 m) due to climate-driven, eustatic sea level changes were often accompanied by essentially no change in depositional and tectonic regimes. In general, changes in these latter two criteria most often reflect major base-level-change episodes and should be used as the final arbiters for recognizing the greatest magnitude, low-order boundaries. Thus a boundary with a substantial amount of change of depositional regime and /or tectonic regime would be ranked higher (lower order) than one with no change in these regimes, even if it seemed that the one with no regime change had similar properties on the basis of the last three criteria.

It must be emphasized that for each basin the interpreter must establish his or her own hierarchy based on the listed criteria. Thus there is no characteristic, generic first-order sequence boundary that can be defined. First-order boundaries in a given study are those that are interpreted to have the largest magnitude in the basin. Thus, a first-order boundary recognized in one basin may be somewhat different from a first-order boundary recognized in another. Once a hierarchy has been established for a basin, that is, each recognized order has been assigned a specific set of characteristics, the assignment of a given boundary to a given order can involve some subjectivity but in

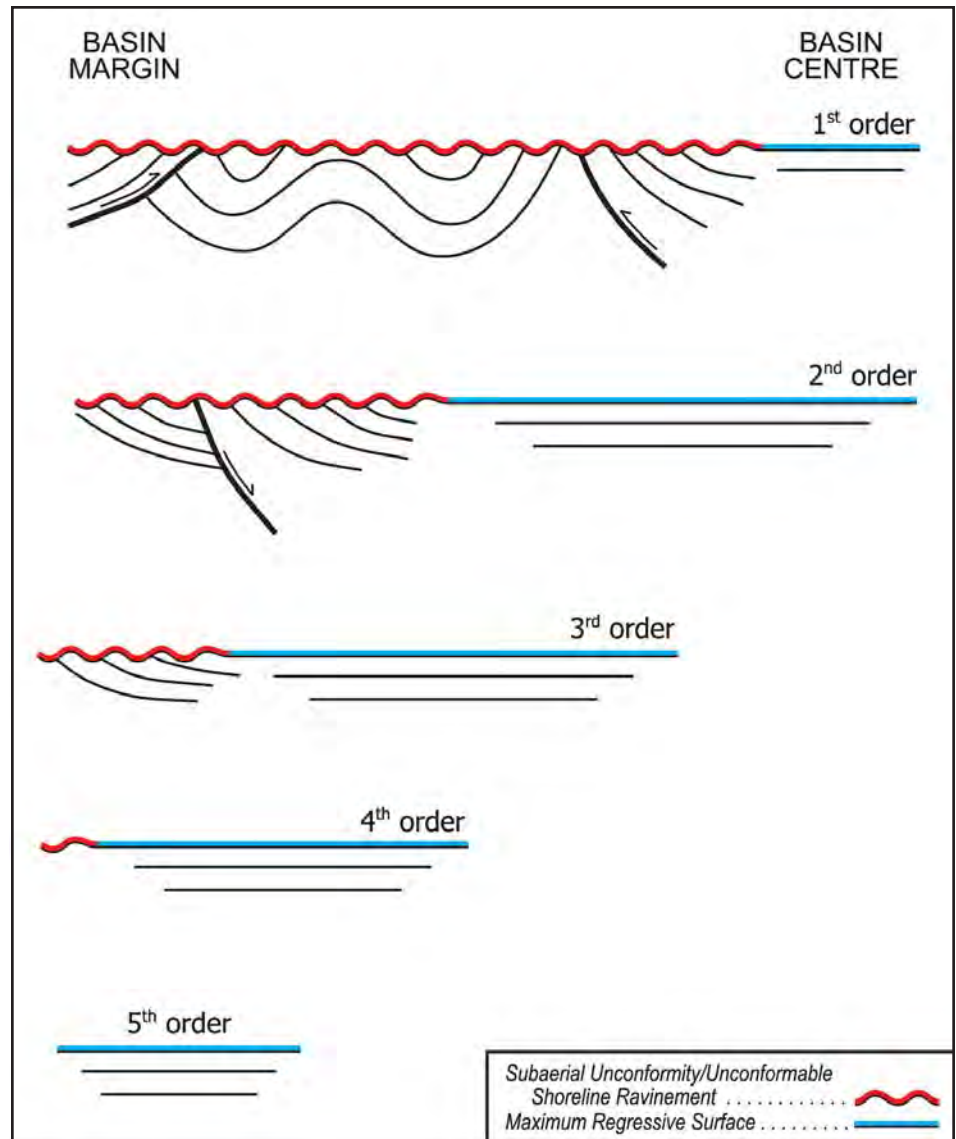

Figure 13.3. A schematic depiction of five orders of sequence boundaries which are determined by observable criteria, such as degree of tectonic regime change and penetration of the unconformity into the basin. The criteria needed to build such a hierarchy must reflect the amount of base-level change which resulted in the formation of the sequence stratigraphic surfaces.

most cases can be done with reasonable consistency and objectivity.

This methodology emphasizes the establishment of a hierarchy based on the interpreted relative magnitude of the depositional sequence boundaries. Thus, if one wants to establish a hierarchy for sequences rather than boundaries, the various sequence boundaries must be ranked first. The order of a sequence is equal to the order of its lowest magnitude (highest order) boundary. Thus a sequence with a fourth-order boundary at the base and a first-order boundary on top is a fourth-order sequence.

This brings us back to our original problem of trying to avoid a chaotic delineation of sequences in a succession with multiple

sequence boundaries of varying magnitude. With the establishment of a hierarchy of sequence boundaries as described above, one simple rule of hierarchies now allows us to recognize a sensible and orderly succession of sequences. This rule states that a sequence cannot contain within it a sequence boundary that has an equal or greater magnitude (equal or lower order) than that of its lowest magnitude (highest order) boundary. For example, a second-order sequence cannot contain a second- or first-order boundary. It can contain many higher order (3rd-6th) boundaries. This is of most importance and is the only way that an orderly delineation of sequences can be produced (Figure 13.4, page 62).

Figure 13.5 (page 63) illustrates an outcrop of Lower to Upper Triassic strata on the



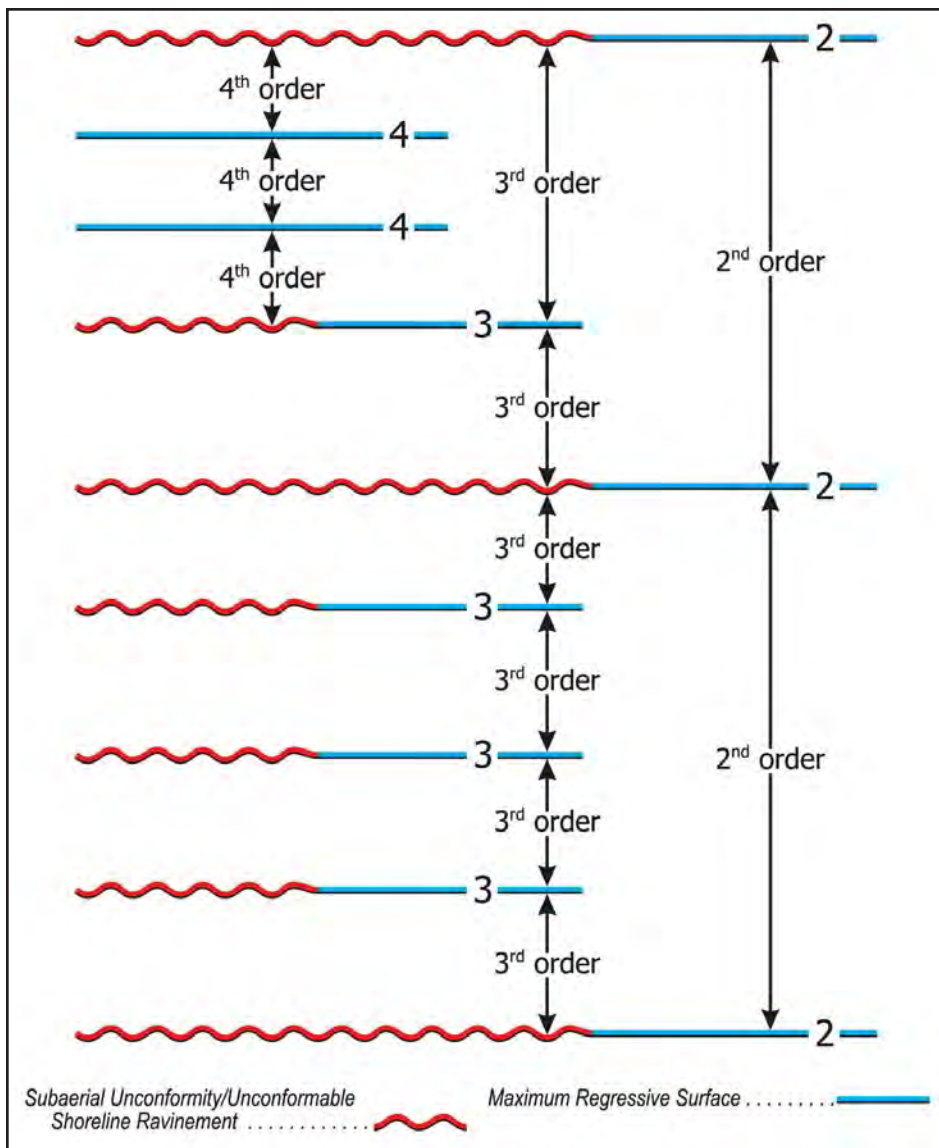

Figure 13.4. Principles of determining the order of a sequence based on hierarchical rules. A sequence cannot contain a sequence boundary with the same or larger magnitude (same or lower order) as its smallest magnitude (highest order) boundary. Thus a 2nd order sequence cannot contain any 1st or 2nd order boundaries. In this way the chaos illustrated in Figure 13.1 can be avoided.

eastern flank of the Sverdrup Basin of Arctic Canada along the north side of Greely Fiord, Ellesmere Island. Three large-magnitude, 2nd order depositional sequence boundaries are present and consist of prominent, unconformable shoreline ravinements. They separate sequences which have different tectonic and depositional regimes and they record major falls of base level followed by large rises. In various areas of the basin, tectonic tilting is present beneath these unconformities (Embry, 1991, 1997). A third-order boundary is delineated in the Lower Triassic 2nd order sequence and it separates red-weathering, fluvial strata of the Smithian 3rd order sequence from the grey-weathering, shallow marine strata of the Spathian 3rd order sequence. Fourth- and fifth-order sequence boundaries (MRSS) can

be delineated in the 3rd order Spathian sequence (Figure 13.5).

Figure 13.6 illustrates an outcrop of the Middle Triassic 2nd order sequence in the Sverdrup Basin at the head of Otto Fiord on north-central Ellesmere Island. The sequence is bound by two 2nd order boundaries, a maximum regressive surface at the base and an unconformable shoreline ravinement at the top. Large base-level changes are represented by these boundaries and they are readily correlated over the entire basin. On the basin margins they are associated with tectonic tilting. Substantial changes in subsidence rate (> 5X) also occurred across both these large magnitude boundaries. A 3rd order sequence boundary (MRS) occurs within the 2nd order sequence and

subdivides it into two 3rd order sequences. Both 3rd order sequences contain 4th order sequence boundaries which at this locality are maximum regressive surfaces.

Figure 13.7 (page 64) illustrates the correlation of various orders of sequence boundaries in the Middle Triassic 2nd order sequence of the Sverdrup Basin in the subsurface of the Loughheed Island area. Notably this area is about 650 km southwest of the outcrop section of Figure 13.5 and the same boundaries are present. Two 2nd order unconformable shoreline ravinements bound the Middle Triassic sequence and a 3rd order unconformable shoreline ravinement occurs within it. A number of 4th order boundaries (MRSS) occur within each 3rd order sequence.

Summary

It is necessary to assign the recognized sequence boundaries and other associated sequence surfaces of a basin to a hierarchy so as to allow the delineation of various orders of sequences. Such a hierarchy is best generated by the use of observable criteria that relate to the magnitude of base-level change that resulted in the generation of the sequence surfaces. The largest magnitude sequence boundaries within a basin are assigned to the first order and sometimes up to six orders of boundaries can be determined.

References

- Embry, A. F. 1991. Mesozoic history of the Arctic Islands. In: *Inuitian Orogen and Arctic Platform: Canada and Greenland*. H.P. Trettin (ed.). Geological Survey of Canada, Geology of Canada no. 3 (also GSA, *The Geology of North America*, v. E), p. 369-433.
- Embry, A. 1993. Transgressive-regressive (T-R) sequence analysis of the Jurassic succession of the Sverdrup Basin, Canadian Arctic Archipelago. *Canadian Journal of Earth Sciences*, v. 30, p. 301-320.
- Embry, A. 1995. Sequence boundaries and sequence hierarchies: problems and proposals. In: *Sequence stratigraphy on the northwest European margin*. R. Steel, et al. (eds.). NPF Special Publication 5, p. 1-11.
- Embry, A. F. 1997. Global sequence boundaries of the Triassic and their recognition in the Western Canada Sedimentary Basin. *Bulletin Canadian Petroleum Geology*, v. 45, p. 415-433.
- Haq, B., Hardenbol, J., and Vail, P. 1988. Mesozoic and Cenozoic chronostratigraphy and cycles of sea level change. In: *Sea level changes: an integrated approach*. C. Wilgus, B. S. Hastings, C. G. Kendall, H. W. Posamentier, C. A. Ross, and J. C.

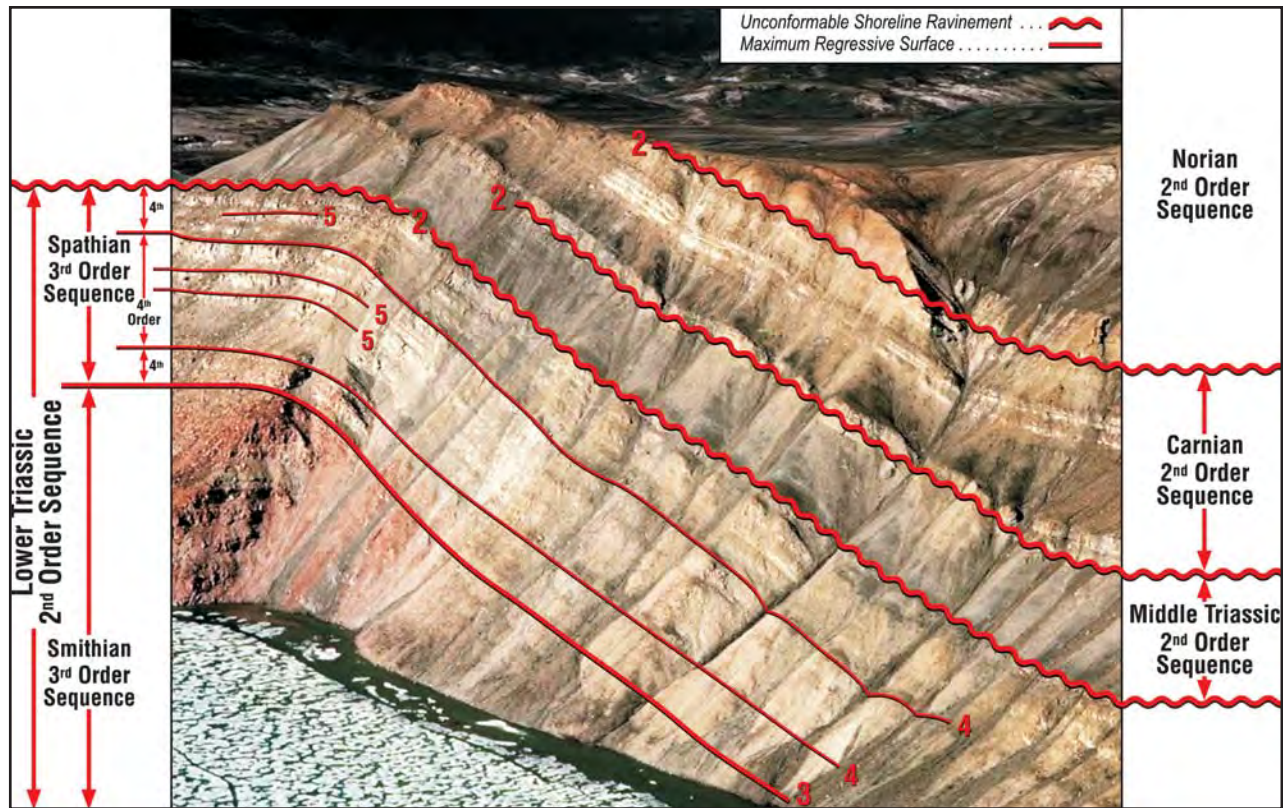

Figure 13.5. An outcrop of Triassic siliciclastic strata on Greely Fiord Ellesmere Island. Three 2nd order depositional sequence boundaries are present. These are unconformable shoreline ravinelements across which there are major changes in tectonic and depositional regimes. Substantial erosion occurred beneath each boundary. A 3rd order boundary occurs within the Lower Triassic 2nd order sequence and 4th and 5th order boundaries (MRSs) are indicated.

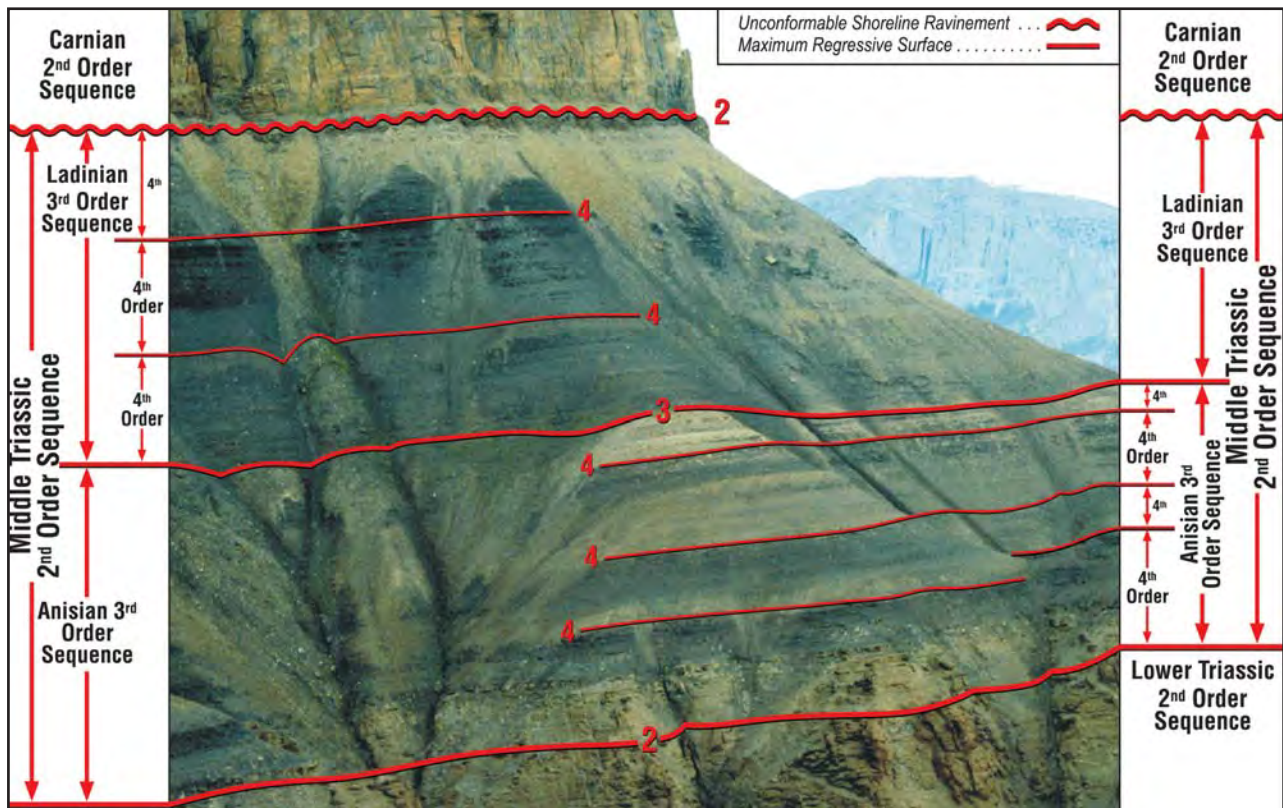

Figure 13.6. An outcrop of the Middle Triassic 2nd order sequence at the head of Otto Fiord, Ellesmere Island. The sequence is bound by a 2nd order boundary, a maximum regressive surface at the base, and an unconformable shoreline ravinement at the top. Once again significant changes in tectonic and depositional regimes occur across these boundaries. A prominent 3rd order boundary (MRS) occurs with this 2nd order sequence and subdivides it into two 3rd order sequences. Smaller magnitude 4th order boundaries are delineated in each 3rd order sequence. Unlike the 2nd and 3rd order boundaries, no change in depositional regime occurs across these 4th order boundaries.



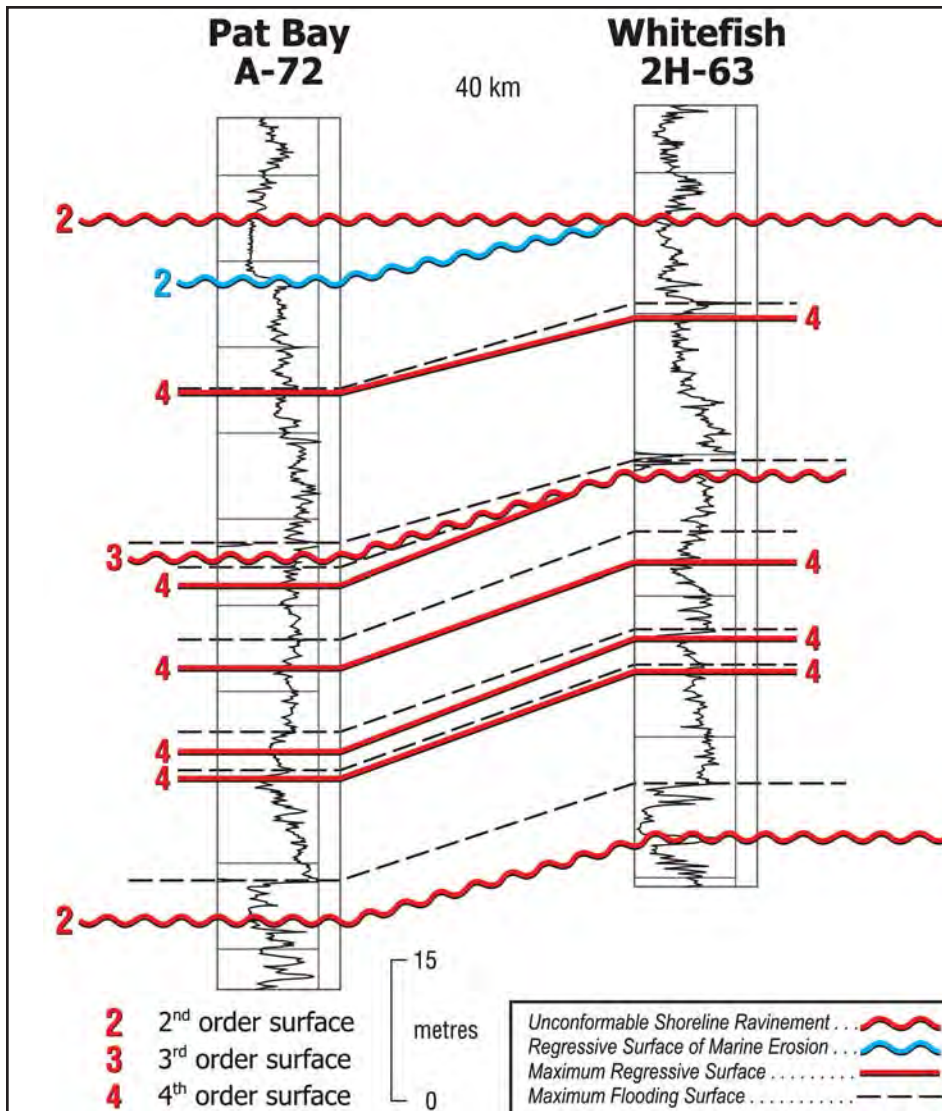

Figure 13.7. The 2nd order unconformable shoreline ravinements that bound the Middle Triassic 2nd order sequence are correlated between two wells in the Lougheed Island area of the western Sverdrup Basin using gamma ray logs. This is the same sequence illustrated in Figure 13.6 but this locality is 650 km to the southwest. The 3rd order boundary within the sequence is a significant unconformable shoreline ravinement in contrast to the maximum regressive surface which formed this same 3rd order sequence boundary on Figure 13.6. Tilt related truncation is apparent on this boundary indicating that tectonics was the primary driver of boundary formation. More subtle, lower magnitude, 4th order boundaries occur within both 3rd order sequences.

Van Wagoner (eds.). *Society of Economic Paleontologists and Mineralogists, Special Publication 42*, p. 40-45.

Mitchum, R. and Van Wagoner, J. 1991. High frequency sequences and their stacking patterns: sequence stratigraphic evidence for high frequency eustatic cycles. *Sedimentary Geology*, v. 70, p. 131-160.

Posamentier, H. and Allen, G. 1999. *Siliciclastic sequence stratigraphy – concepts and applications*. *Society of Economic Paleontologists and Mineralogists Concepts in Sedimentology and Paleontology*, # 7, 210 p.

Vail, P. et al. 1977. *Seismic stratigraphy and global changes in sea level*. In: *Seismic stratigraphy: applications to hydrocarbon exploration*. C. Payton (ed.). *American Association of Petroleum Geologists Memoir 26*, p. 49-212.

Vail, P. et al. 1991. *The stratigraphic signatures of tectonics, eustasy and sedimentology – an overview*. In: *Cycles and events in stratigraphy*, G. Einsele, et al. (eds.), Springer-Verlag, New York, p. 611-159.



Practical Sequence Stratigraphy XIV

Correlation

by Ashton Embry

Introduction

In previous articles in this series, I have described the various types of sequence stratigraphic surfaces that have been recognized, as well as the different types of sequence stratigraphic units that have been defined on the basis of those surfaces. However, it must be emphasized that the primary contribution of sequence stratigraphy to petroleum geology is that it provides an excellent methodology for correlating strata and this topic is addressed herein.

Stratigraphic correlation is accomplished by matching distinct stratigraphic surfaces or horizons recognized in a stratigraphic succession at one locality to their equivalent counterparts in a succession at another locality. This allows the extension of recognized stratigraphic units and surfaces into new geographic areas and potentially to areas around the world.

One of the main goals of correlation is to establish an approximate time-stratigraphic correlation framework so as to allow facies relationships to be determined and predictions of facies occurrences to be made. Interpretations of depositional history and

paleogeographic evolution also depend upon such a framework built by the correlation of stratigraphic surfaces that have a low diachroneity or are time barriers. Low diachroneity surfaces are often delineated in biostratigraphy, magnetostratigraphy, and chemostratigraphy but such methods are often not available for subsurface studies. Furthermore they can be very costly and time consuming.

Sequence stratigraphy is very useful for constructing an approximate time-stratigraphic framework because, as previously described, a number of the surfaces of sequence stratigraphy are either time barriers or have low diachroneity. Most importantly, sequence stratigraphy is readily applicable to subsurface studies and can be done with seismic, well log, and / or core databases. In this article, the use of sequence stratigraphy for correlation is discussed and a number of examples of correlations using sequence stratigraphy with well logs are provided.

Sequence Stratigraphic Surfaces Useful for Correlation

As discussed in previous articles, sequence stratigraphic surfaces are those that

represent breaks in the stratigraphic record or changes in depositional trend. Six, material-based surfaces have been defined and their relationships to time were discussed in Embry 2008a, b, and c. The material-based surfaces of sequence stratigraphy that are either time barriers or have low diachroneity, and are thus useful for establishing a correlation framework, are:

- Subaerial unconformity (SU) (time barrier),
- Unconformable shoreline ravinement (SR-U) (time barrier),
- Slope onlap surface (SOS) (time barrier),
- Maximum regressive surface (MRS) (low diachroneity), and
- Maximum flooding surface (MFS) (low diachroneity).

The material-based surfaces of sequence stratigraphy that are not useful for constructing an approximate time correlation framework are those that are very diachronous. These are the regressive surface of marine erosion (RSME) and the diastemic portion of a shoreline ravinement (SR-D) (Embry, 2008a, b). However, it is useful to correlate such surfaces as part of the delineation of facies distributions within the correlation framework.

As discussed in Embry (2009), two, time-based surfaces have also been defined as part of sequence stratigraphy although a reasonable argument can be made that such surfaces are much better assigned to chronostratigraphy rather than sequence stratigraphy. These time-based surfaces are the basal surface of forced regression (BSFR), which equals the time surface at the start of regional base-level fall, and the correlative conformity (CC), which represents the time surface at the start of regional base-level rise. Like all time-based surfaces, these surfaces have no defining physical characteristics and thus their use for correlation is very limited. This assessment is supported by the lack of any publications that have used such surfaces for correlation of well log sections.

Correlating Shallow Marine Strata

The sequence stratigraphic model for siliciclastics in a ramp setting (Embry, 2008d) is illustrated in Figure 14.1 and shows the

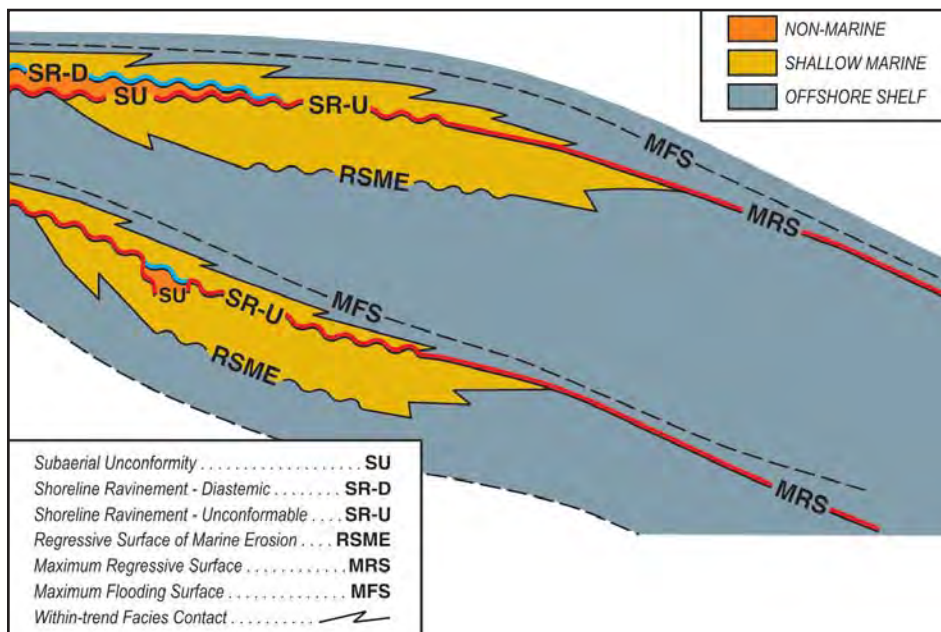

Figure 14.1. Sequence stratigraphic model for a siliciclastic ramp setting (Embry, 2008d). Note that the SR-U, MRS, and MFS all occur in shallow marine strata and these surfaces are excellent for correlation in such strata. Towards the basin margin, nonmarine strata become intercalated with the shallow marine strata and an SU and SR-D can also be delineated and correlated.



three surfaces of sequence stratigraphy that are useful for the correlation of shallow marine strata. These are the unconformable shoreline ravinement, the maximum regressive surface, and the maximum flooding surface. As shown on the model (Figure 14.1, page 65), the maximum flooding surface is often very widespread and it is usually the easiest surface to recognize and correlate. As discussed in Embry (2008c), the MFS represents the change from a fining-upward trend to a coarsening-upward one, and on gamma logs is best placed at the highest gamma horizon unless higher resolution data (e.g., core) support a different placement.

Between every two MFSs in shallow marine strata, there will be either an MRS or an SR-U. The maximum regressive surface marks the change from a coarsening-upward trend to a fining-upward one and on gamma logs it is best placed at the lowest gamma horizon (Embry, 2008b) unless, once again, more detailed data indicate a different placement. As seen on Figure 14.1 (page 65), the MRS correlates laterally to an unconformable shoreline ravinement (SR-U) and, in combination, these two surfaces allow the delineation of a widespread correlative horizon. On gamma logs, an SR-U is often marked by an abrupt contact, overlain by a fining-upward (increasing gamma) succession (Figure 8 in Embry 2008b). Confirmation of the existence of an SR-U requires the demonstration of truncated strata below it.

Figure 14.2 is a three-well, gamma-ray cross-section of the lower Charlie Lake Formation (Upper Triassic) in northwestern Alberta and the data were kindly supplied by my colleague, Jim Dixon. The Charlie Lake Formation consists mainly of interbedded

shale, siltstone, and sandstone with less common limestone and anhydrite. The depositional setting was a shallow, restricted seaway and individual units can be correlated over large areas (J. Dixon, pers. comm., 2007).

The datum for this cross-section is a lithostratigraphic one, the base of the Charlie Lake Formation, which is marked by a unit of anhydrite overlying a sandstone unit at the top of the Halfway Formation. A lithostratigraphic contact is usually not the best choice for a datum because of the potential high diachroneity of such a surface but it is certainly objective. In this case, this contact appears to have low diachroneity as demonstrated by its near parallelism with an easily correlatable MRS about 10 m above. I have correlated this cross-section mainly with MRSs and MFSs delineated on the basis of gamma ray signature.

In most cases, where control is very close and a cross-section is not long, the MFSs and MRSs will parallel each other because differences in subsidence rates tend to be very small over short distances. The presence of an unconformity is suspected when two different sets of parallel MRSs and MFSs are present and are at any angle to each other. On this basis, I have interpreted the occurrence of an unconformable shoreline ravinement (SR-U) beneath a sharp-based, fining-upward, limestone unit (informally called the “A marker”) (Figure 14.2). This interpretation is supported by the truncation of an MRS and the progressive eastward thinning of the section between the “A marker” and the first correlatable MRS above the SR-U nearly parallel it and minor, eastward onlap is expressed as a slight

thinning of the section between the SR-U and the overlying MFS.

Figure 14.3 illustrates a stratigraphic cross-section of Upper Triassic, shallow marine strata on the southern flank of the Sverdrup Basin in the Melville Island area of Arctic Canada. In this case, the wells are much farther apart than the previous example and more section is present (300 m versus 50 m). Because of this, only large-magnitude surfaces have been correlated, although there are opportunities for correlating smaller-scale surfaces. The datum is a prominent unconformable shoreline ravinement (SR-U) near the top of the succession and it passes basinward into a readily recognizable MRS that separates two distinctly different depositional regimes (2nd order boundary). Because this surface was essentially horizontal when it was formed (shoreface erosion at sea level), it makes a very good datum.

Once again, MRSs and MFSs are correlated on the basis of gamma ray signature and sample descriptions. Unconformable shoreline ravinements are delineated where truncation can be demonstrated. Some minor depositional thickening for individual units is visible downdip, but notably, most changes in thickness are due to the effects of marginward truncation beneath the unconformities. This indicates that the unconformities were generated by tectonic movements rather than by eustasy. This topic will be more fully explored in the next article.

Figure 14.4 also illustrates shallow marine strata in a ramp setting (Lower Jurassic, western Sverdrup Basin) and in this case, there is a large distance between the control points and the line of section is close to the direction of depositional dip. In sections parallel to depositional strike or those which extend only a short distance down dip (e.g., Figures 14.2, 14.3), depositional dip has little to no effect on stratal geometry of the larger magnitude surfaces. However, in this case, depositional dip is a significant factor in the geometry of the correlated surfaces.

The succession portrayed in Figure 14.4 is conformable with the only unconformity present being an SR-U at the base of the succession. A prominent maximum flooding surface (3rd order) is used as a datum for lack of a better one. It must be kept in mind that this MFS datum was not a horizontal horizon at the time of formation but sloped basinward, approximating the sea floor dip. Using an originally sloping surface as a horizontal datum will distort original stratal geometries somewhat.

The larger-magnitude MRSs and MFSs are

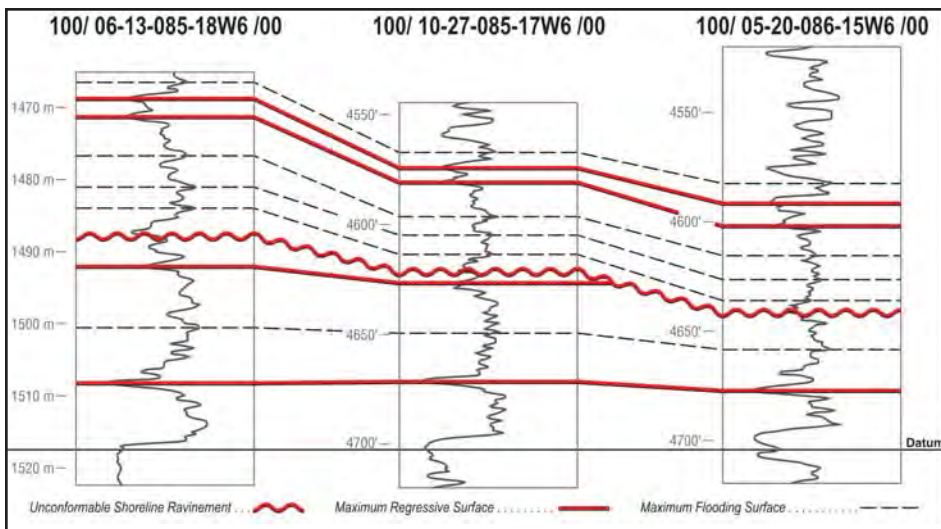

Figure 14.2. Stratigraphic cross-section of lower portion of Charlie Lake Formation, northwest, Alberta. The datum is the base of the Charlie Lake, a lithostratigraphic surface. Maximum regressive surfaces, maximum flooding surfaces, and one unconformable shoreline ravinement have been correlated. The SR-U truncates strata eastwards and very minor onlap occurs above it. Data courtesy of J. Dixon.

correlated on Figure 14.4 and any smaller-scale correlation is precluded by the large distances between control points. The correlatable surfaces approximate the dipping sea floor at the time of their formation and thus diverge from the datum because of the greater water depths to the west. The sandstones that underlie the MRSs in the east change facies to shale and siltstone basinward as water depth increased. The first MFS below the datum is well characterized on the sonic log by a very slow travel time (high clay content). This surface can be readily recognized throughout the basin and marks the height of a major transgression in the early Toarcian (a global event).

In summary, maximum flooding surfaces, maximum regressive surfaces and unconformable shoreline ravinement surfaces are ideal surfaces for correlation in shallow marine strata. Various orders of these surfaces are usually present and the low-order, high-magnitude surfaces are the easiest to correlate. High-order, low-magnitude surfaces can be correlated if reasonably close control is available.

Correlating Interbedded Nonmarine and Shallow Marine Strata

As shown of Figure 14.1 (page 65), when nonmarine strata are intercalated with shallow marine strata on the basin margins, the potential for the recognition of subaerial unconformities (SU) and diastemic shoreline ravinements (SR-D) exists. The reason for this is that the occurrence of nonmarine strata either directly above (SU) or directly below (SR-D) is one of the defining characteristics of these surfaces. If nonmarine strata are not present in a succession, then SUs and SR-Ds cannot be delineated.

Figure 14.5 (page 68) is a cross-section of an interval of Lower Cretaceous, interbedded marine and non-marine strata of the lower portion of the Isachsen Formation on Eglinton Island, Arctic Canada (Sverdrup Basin). Prominent subaerial unconformities are delineated beneath very coarse-grained, fluvial channel deposits and the basal one is used as the datum. This SU overlies offshore marine strata and is a major 1st order boundary in the basin. The SU's allow the lower Isachsen Formation to be subdivided into two depositional sequences.

MFSs can be delineated and correlated in the marine interval of each sequence and these surfaces subdivide each sequence into a lower transgressive systems tract (TST) and an upper regressive systems tract (RST). The contact between nonmarine strata below and marine strata above occurs within the TST of each sequence and is a diastemic shoreline ravinement. The highly diachronous nature

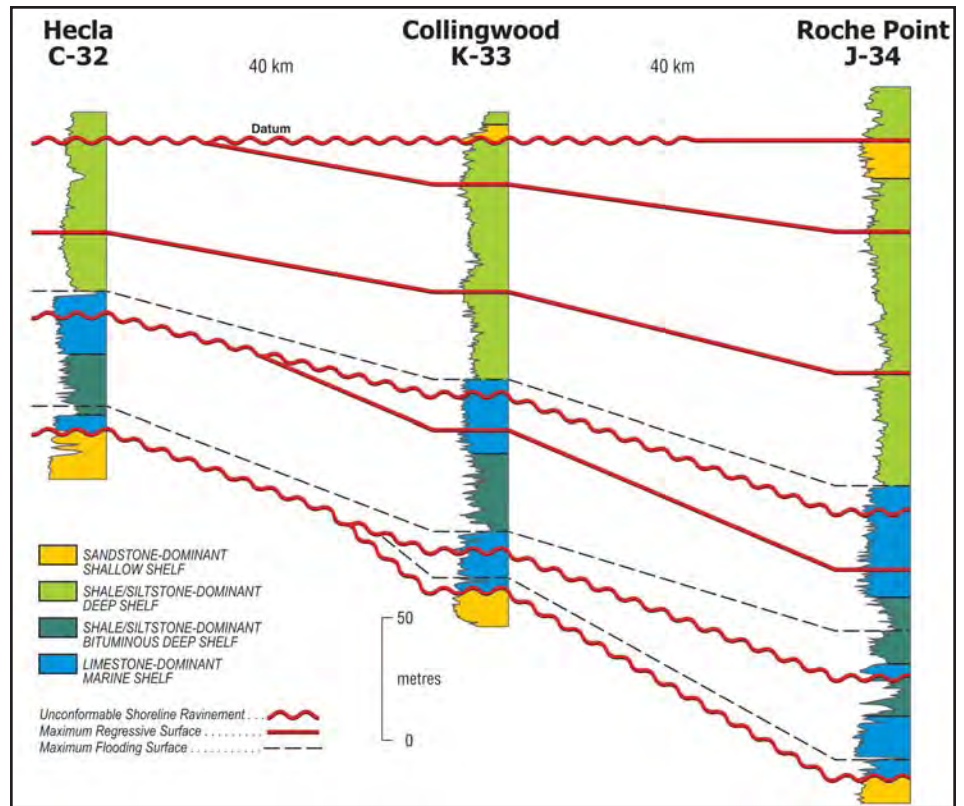

Figure 14.3. Stratigraphic cross-section of Upper Triassic (Carnian) strata on the southwest flank of the Sverdrup Basin, Melville Island, Arctic Canada. Only large-magnitude sequence stratigraphic surfaces have been correlated and a prominent SR-U that caps the Carnian succession is used as the datum. An SR-U forms the base of the succession and two SR-Us occur within. MRSs and MFSs are truncated by the SR-Us and the lowermost Carnian sequence is absent in the well on the basin edge (Hecla-C-32).

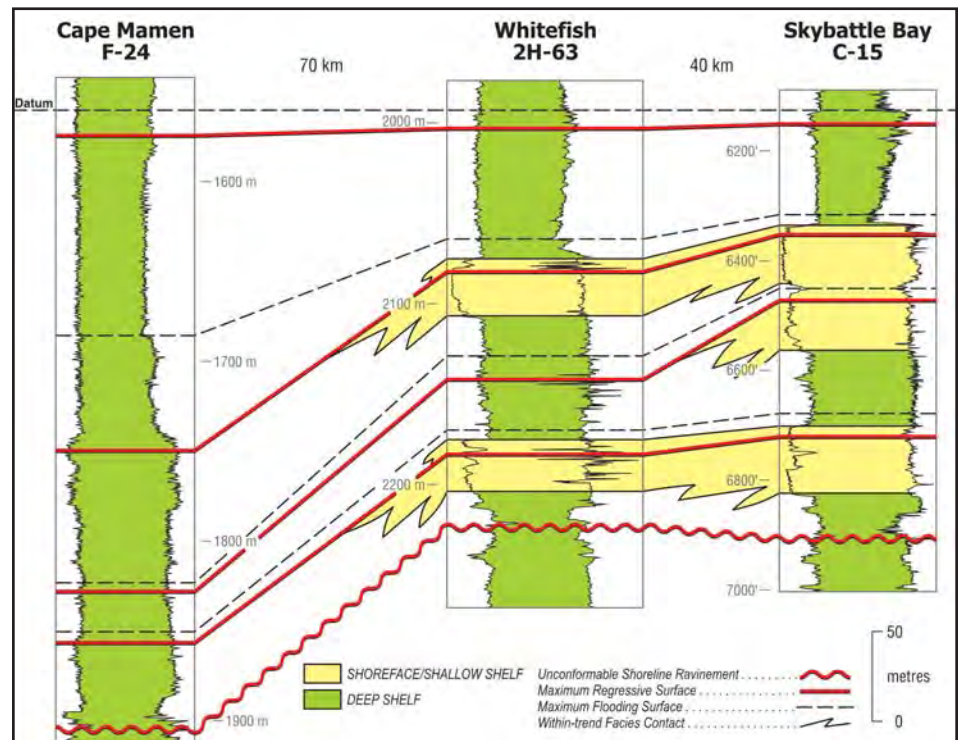

Figure 14.4. Stratigraphic cross-section of Lower Jurassic strata in the southwestern Sverdrup Basin. The datum is a prominent MRS near the top of the Lower Jurassic (late Toarcian). The cross-section is dip oriented and extends for over 100 km. Large-magnitude MRSs and MFSs have been correlated and they all dip basinward, approximating the original sea floor dip. Sandstone units found in the eastern two wells "shale-out" basinward beneath the MRSs.



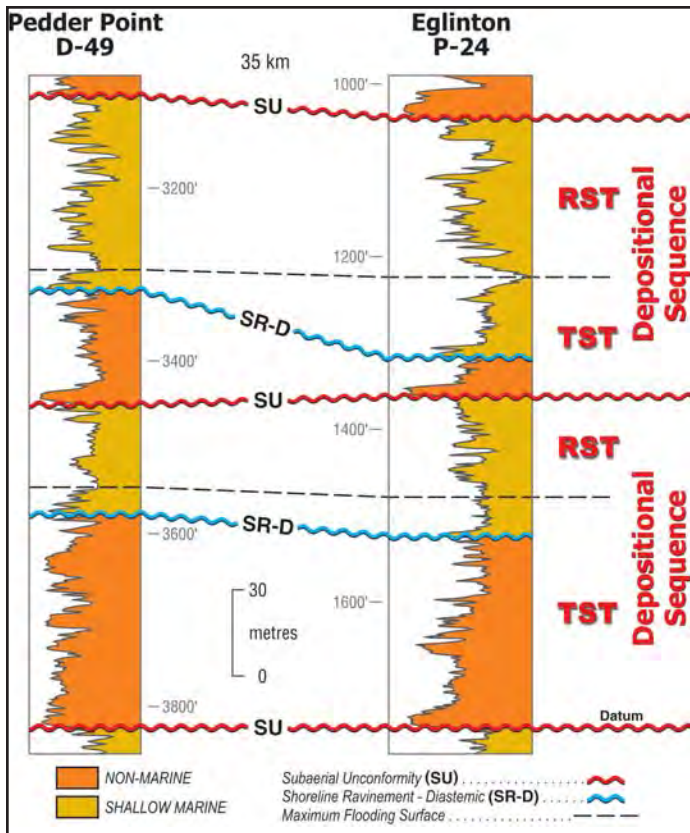

Figure 14.5. Stratigraphic cross-section of Lower Cretaceous strata (lower Isachsen Fm) from the southwestern flank of the Sverdrup Basin, Eglinton Island, Arctic Canada. The succession consists of intercalated nonmarine and shallow marine strata. A 1st order SU at the base of the succession is used as the datum. The delineation of two other SUs allows two depositional sequences to be defined. The correlation of an MFS within the marine strata of each sequence allows each sequence to be subdivided into a transgressive systems tract (TST) and a regressive systems tract (RST). A diastemic shoreline ravinement (SR-D) occurs within each TST at the boundary between the nonmarine strata and overlying marine strata. Because of the highly diachronous nature of the SR-Ds (climbs stratigraphically), such surfaces are not used as part of the time correlation framework or as a system tract boundary.

of such a SR-D is well illustrated by the upper one which climbs stratigraphically upward (i.e., becomes younger) towards the more marginal well on the left (Figure 14.5). Note that the correlated MFSs essentially parallel the datum and each other (i.e., very low diachroneity) and no depositional dip is discernable for the MFSs on this section.

Figure 14.6 illustrates the correlatable surfaces associated with an incised valley deposit that can be considered as a plum of nonmarine strata in a pudding of shallow marine deposits. The cross-section consists of four, reasonably close wells in southern Saskatchewan and includes the transition from the nonmarine Mannville Group at the base to the deep shelf, marine shales of the Lower Colorado Group at the top (logs and facies interpretation from O. Catuneanu). These strata are mainly shallow marine sandstone, siltstone, and shale but an interval of fluvial sandstone occurs in two wells. A

prominent MRS has been chosen as the datum and it is overlain by an easily picked MFS. The surface at the top of the nonmarine Mannville strata is a diastemic shoreline ravinement (contact of marine strata overlying nonmarine strata).

The presence of the isolated pod of nonmarine sandstone complicates an otherwise standard correlation of MRSs and MRSs. A subaerial unconformity (SU) must be placed at base of the nonmarine strata to explain their isolated occurrence. A diastemic shoreline ravinement (SR-D) once again occurs at the contact between the fluvial strata and the overlying marine strata. Because a shoreline ravinement is usually not an isolated surface, it is reasonable, if not mandatory, to extend the SR that occurs

on top of the fluvial strata into the adjacent marine strata. The SR in the marine strata would be a significant unconformity (SR-U) (SU eroded) as opposed to being a minor diastem as it is when it overlies the fluvial strata. Its placement in the marine strata is guided by the constraints that it should be at approximately the same stratigraphic level as the SR-D (SR is close to a horizontal surface) and it should occur at the base of a fining-upward succession.

As shown on Figure 14.6, the SR-U in the marine strata might have otherwise been interpreted as an MRS if the control points with the fluvial strata and the accompanying SR-D were not available. Conversely, if an SR-U is interpreted to occur in a section of shallow marine strata (e.g., Figures 14.2, 14.3, and 14.4), then the occurrence of incised valley, nonmarine deposits, which stratigraphically hang down from the SR, is a potential exploration target for that area.

Finally, it is worth noting that the stratigraphic interval between the SR and the overlying MFS is thicker and sandier where it overlies the incised valley strata where supply was greater.

Correlation in Fluvial Strata

Correlation with sequence stratigraphy in successions of fluvial strata that have no marine intercalations can be difficult. The only sequence stratigraphic surface that is common is the subaerial unconformity that occurs at the base of channel deposits or at the top of paleosols. It is difficult to correlate such subaerial unconformities with confidence and it is often even harder to establish a hierarchy of surfaces. It is also important to distinguish between subaerial unconformities that are regional truncation surfaces and subaerial diastems (channel scours) that are the product of river migration during rising base level.

A subaerial unconformity at the base of an incised valley represents a regional base-level fall and is likely a large-scale sequence boundary. It must correlate with a soil horizon in the interfluvial areas although it is usually very difficult to establish such a correlation without excellent control. A good example of such work is McCarthy and Plint (1998) who correlated subaerial unconformities in a well exposed succession of channel deposits and overbank strata with soil horizons. Their work demonstrates the need for very close control for such correlations.

It is important to try to recognize and correlate the large-scale subaerial unconformities that may be present. These are sometimes associated with a significant change in grain composition and / or clast size. Other stratigraphic data such as chemostratigraphic and magnetostratigraphic data can be integrated to help identify SUs. Zaitlin et al. (2002) and Ratcliffe et al. (2004) provide a solid example of identifying regional SUs in a fluvial succession through the use of changes in mineralogical and chemical composition.

Maximum flooding surfaces can sometimes be tentatively determined in fluvial strata and may be represented by a horizon that exhibits a marine influence (e.g., brackish water facies). In absence of any indication of a marine influence, an MFS in fluvial strata can be delineated with reasonable objectivity within the interval with the highest ratio of overbank fines to channel sandstone (i.e., the change from fining-upward to coarsening-upward). This interval also tends to be associated with the thickest and most common coal seams. Overall, widespread MFSs do not appear to be common in fluvial

strata and this is supported by the general lack of regionally correlatable seismic reflectors in such strata.

In summary, SUs are the main sequence stratigraphic surfaces available for correlation in fluvial strata. However, it is usually very difficult to delineate and correlate such surfaces and close control and data from other stratigraphic disciplines are often required.

Correlating Deep Marine Siliciclastics

Sequence analysis in deep-water siliciclastics also presents substantial challenges. The sequence stratigraphic surfaces that can be expected in this environment are the slope onlap surface (SOS), maximum regressive surface (MRS), and the maximum flooding surface (MFS). In an interval of stacked submarine fan deposits, an MRS can be drawn on top of the units of coarsening-upward, turbiditic fan deposits (e.g., Johannessen and Steel, 2005; Hodgson et al., 2006). Such a horizon may occur near the top or well within the package of turbidites.

In the same succession, the MFS can be drawn at the horizon of the finest sediment, usually within a shale unit that separates thick intervals of turbidites (Sixsmith et al., 2004). Identification of an SOS in siliciclastics is difficult and is best done on seismic sections where the stratal geometry inside the thick, shale-dominant slope succession can be determined. Some workers have interpreted the base of the first turbidite as a correlatable sequence stratigraphic surface (e.g., Posamentier et al., 1988; Van Wagoner et al., 1990). However, in many cases such a surface is simply a scoured, within-trend facies contact (a diastem within a coarsening upward, regressive succession) and is not a surface of sequence stratigraphy. In general, the base of a turbidite package is very gradational and is diachronous both down dip and laterally (Hodgson et al., 2006). In some instances, where turbidites onlap the slope, the base of the turbidite succession, where it onlaps, coincides with an SOS.

Correlating Carbonate Strata

Sequence analysis for carbonate strata is in many respects very similar as that for siliciclastic strata although some differences do occur. These differences are due mainly to differences in how carbonate sedimentation responds to base-level change as compared to siliciclastic sedimentation. For example, during times of falling base level, rates of siliciclastic sedimentation in marine areas are often enhanced due to increased delivery of sediment to a basin. However, carbonate sedimentation in a shelf / slope / basin setting, often significantly decreases with base-level fall because much

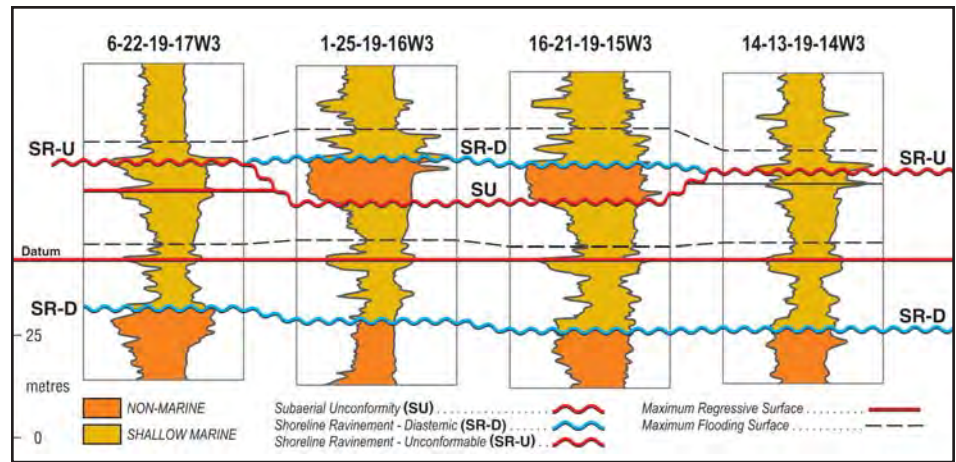

Figure 14.6. Stratigraphic cross-section of Lower Cretaceous strata from southern Saskatchewan. The non-marine strata of the Mannville Group are overlain by a succession of shallow marine strata that overall deepen upward to offshore shale and siltstone of the Lower Colorado Group. A prominent MRS is used as the datum. Fluvial strata occur in two wells and an SU is delineated below these strata with an SR-D above. The shoreline ravinement is correlated into the adjacent marine strata as an SR-U. The SU is cut off by the SR-U, forming the flanks of an incised valley. Data courtesy of O. Catuneanu.

of the carbonate shelf (the carbonate sediment factory) is exposed. However, the same types of surfaces of sequence stratigraphy that are recognized in siliciclastic strata occur in carbonate strata. They can have a few different attributes in carbonates than they do in siliciclastics. Notably the SOS is often very well expressed and can be readily delineated when present.

For shallow marine carbonates, these include a maximum regressive surface, maximum flooding surface, shoreline ravinement, and regressive surface of marine erosion. Subaerial unconformities form during times of base-level fall but most become modified by subsequent marine erosion and are thus unconformable shoreline ravinements.

The determination of MRSs and MFSs depends on facies analysis and the determination of sediment supply trends in the carbonate strata. These are often not as clearly expressed on mechanical logs as they are in siliciclastic rocks. They can often be more easily delineated on logs when fine-grained clastic sediment is part of the depositional system (see Wendte and Uyeno, 2005). For reefs and carbonate banks, one or more SOSs are almost always present on the slopes.

Figure 14.7 (page 70) illustrates a sequence correlation for a carbonate-dominant succession that contains carbonate ramp deposits that lie both below (Nisku Fm) and above (Wolf Lake, Blue Ridge mbrs) an interval of reef (Zeta Lake Mbr) and off-reef strata (Cynthia Mbr). These data were supplied by Jack Wendte and are from the West Pembina area of Alberta (see Wendte et al., 1995).

MRSs and MFSs are readily correlated in the carbonate ramp deposits below the reef (Figure 14.7, page 70). A slope onlap surface has been delineated on the flank of the reef and is marked by a high gamma (starved interval) in the off-reef well. The SOS joins with an SR-U on top of the reef and both these surfaces formed when base level fell such that most of the reef was exposed (SR-U) and the slope was starved of sediment (SOS). During the later stage of base-level fall, argillaceous siliciclastic sediment prograded into the area and onlapped the SOS (Figure 14.7, page 70).

With base-level rise and transgression, carbonate sediment production greatly increased and siliciclastic sediment input ceased. Carbonate ramps then built out over the siliciclastics which had filled in the deep, inter-reef areas. MRSs and MFSs are readily correlated in these post-reef ramp strata. This example shows how the delineation and correlation of sequences stratigraphic surfaces helps to elucidate the depositional history of a succession.

Summary

Sequence stratigraphy provides an excellent methodology for constructing an approximate time-stratigraphic framework through the delineation and correlation of sequence stratigraphic surfaces which have low diachroneity (maximum regressive surface, maximum flooding surface) or are time barriers (subaerial unconformity, unconformable shoreline ravinement, slope onlap surface). Such a framework is essential for predicting facies development away from control points and for reconstructing depositional history and paleogeographic evolution.



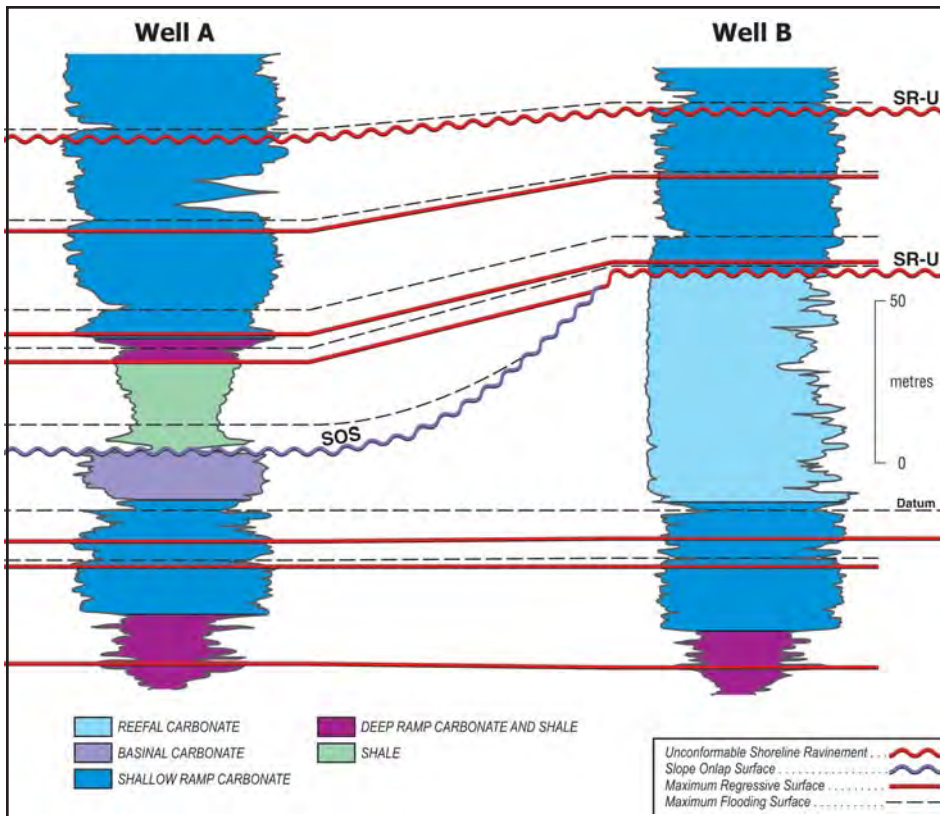

Figure 14.7. Stratigraphic cross-section of Upper Devonian carbonate strata in the west Pembina area of western Alberta. Carbonate ramp strata, in which MRSs and MFSs are readily correlated, occur below and above a reef / off-reef interval. An unconformable shoreline ravinement (SR-U) caps the reefal strata and correlates with a prominent slope onlap surface (SOS) on the reef flank. Siliciclastic shale and siltstone, deposited during base-level fall, onlap the SOS and are overlain by prograding ramp carbonates deposited during the subsequent base-level rise. Data courtesy of J. Wendte.

Each general depositional environment has at least one type of sequence stratigraphic unit that is useful for correlation. In successions with intercalated nonmarine and shallow marine, siliciclastic strata, four surface types are often present (SU, SR-U, MRS, MFS). In deep marine, siliciclastic settings, correlatable surfaces include MRS, MFS, and SOS, with the SOS often being hard to delineate.

In carbonate strata, subaerial unconformities (SU) are very rare and unconformity surfaces on the basin flanks are almost always unconformable shoreline ravinements (SRU). Slope onlap surfaces are common in carbonate platform / slope / basin and reef settings and are usually readily delineated and correlated.

Correlation from basin edge to basin centre is best accomplished with maximum flooding surfaces. A combined maximum regressive surface and unconformable shoreline ravinement is also useful for such regional correlations.

References

Embry, A. F. 2008a. *Practical Sequence*

Stratigraphy IV: The Material-based Surfaces of Sequence Stratigraphy, Part 1: Subaerial Unconformity and Regressive Surface of Marine Erosion. Canadian Society of Petroleum Geologists. *The Reservoir*, v. 35, issue 8, p. 37-41.

Embry, A. F. 2008b. *Practical Sequence Stratigraphy V: The Material-based Surfaces of Sequence Stratigraphy, Part 2: Shoreline ravinement and Maximum Regressive Surface.* Canadian Society of Petroleum Geologists. *The Reservoir*, v. 35, issue 9, p. 32-39.

Embry, A. F. 2008c. *Practical Sequence Stratigraphy VI: The Material-based Surfaces of Sequence Stratigraphy, Part 3: Maximum Flooding Surface and Slope Onlap Surface.* Canadian Society of Petroleum Geologists. *The Reservoir*, v. 35, issue 10, p. 36-41.

Embry, A. F. 2008d. *Practical Sequence Stratigraphy VII: The base-level change model for material-based sequence stratigraphic surfaces.* Canadian Society of Petroleum Geologists. *The Reservoir*, v. 35, issue 11, p. 31-37.

Embry, A. F. 2009. *Practical Sequence Stratigraphy VIII: The Time-based Surfaces of Sequence Stratigraphy.* Canadian Society of Petroleum

Geologists. *The Reservoir*, v. 36, issue 1, p. 27-33.

Hodgson, D., Flint, S., Hodgetts, D., Drinkwater, N., Johannessen, E., and Luthi, S. 2006. *Stratigraphic Evolution of Fine-Grained Submarine Fan Systems, Tanqua Depocenter, Karoo Basin, South Africa.* *Journal of Sedimentary Research*, v. 76, p. 20-40.

Johannessen, E. J. and Steel, R. J. 2005. *Shelfmargin clinofolds and prediction of deep water sands.* *Basin Research*, v. 17, p. 521-550.

McCarthy, P. J. and Flint, A. G. 1998. *Recognition of interfluvial sequence boundaries: integrating paleopedology and sequence stratigraphy.* *Geology*, v. 26, p. 387-390.

Posamentier, H., Jervey, M., and Vail, P. 1988. *Eustatic controls on clastic deposition I-conceptual framework.* In: *Sea level changes: an integrated approach.* C. Wilgus, B. S. Hastings, C. G. Kendall, H. W. Posamentier, C. A. Ross, and J. C. Van Wagoner (eds.). *Society of Economic Paleontologists and Mineralogists, Special Publication 42*, p. 109-124.

Ratcliffe, K., Wright, A., Hallsworth, C., Morton, A., Zaitlin, B., Potocki, D., and Wray, D. 2004. *An example of alternative correlation techniques in a low accommodation setting, nonmarine hydrocarbon setting: the (Lower Cretaceous) Mannville Basal Quartz succession of southern Alberta.* *AAPG Bulletin*, v. 88, p. 1419-1432.

Sixsmith, P., Flint, S., Wickens, H., and Johnson, S. 2004. *Anatomy and stratigraphic development of a basin floor turbidite system in the Lainsburg Formation, Main Karoo Basin, South Africa* *Journal Sedimentary Research*, v. 74, p. 239-254.

Van Wagoner, J. C., Mitchum, R. M., Campion, K. M., and Rahmanian, V. D. 1990. *Siliciclastic sequence stratigraphy in well logs, cores and outcrops: AAPG Methods in Exploration*, no. 7, 55 p.

Wendte, J., Bosman, M., Stoakes, F., and Bernstein, L. 1995. *Genetic and stratigraphic significance of the Upper Devonian Frasnian Z marker, west-central Alberta.* *Bulletin Canadian Petroleum Geology*, v. 43, p. 393-406.

Wendte, J. and Uyeno, T. 2005. *Sequence stratigraphy and evolution of Middle to Upper Devonian Beaverhill Lake strata, south-central Alberta.* *Bulletin Canadian Petroleum Geology*, v. 53, p. 250-354.

Zaitlin, B. A., Warren, M. J., Potocki, D., Rosenthal, L., and Boyd, R. 2002. *Depositional styles in a low accommodation foreland basin setting: an example from the Basal Quartz (Lower Cretaceous), south-central Alberta.* *Bulletin Canadian Petroleum Geology*, v. 50, p. 31-72.



Practical Sequence Stratigraphy XV

Tectonics vs. Eustasy and Applications to Petroleum Exploration

by Ashton Embry

Introduction

The delineation and correlation of sequence stratigraphic surfaces allows one to build an approximate time stratigraphic framework, which is essential for determining facies relationships. This is perhaps the primary use of sequence stratigraphy and it was described in the last article of this series (Embry, 2009). Once the sequence stratigraphic framework has been established and the facies relationships resolved, the depositional history of the succession can be interpreted in terms of base-level changes because the sequence stratigraphic surfaces were generated by changes in base level as discussed in Embry (2008).

For example, the recognition and correlation of a subaerial unconformity allows one to interpret that a base-level fall occurred over the entire extent of the unconformity. If an unconformable shoreline ravinement is mapped, it leads to the interpretation that the area underwent base-level fall followed by a rapid base-level rise. Thus a sequence stratigraphic correlation framework not only allows the facies relationships to be established but it also provides a means of interpreting depositional history in terms of base-level movements. When interpretations of base-level changes are made, it is also worthwhile to try to determine which external factor was responsible for the recognized base-level changes. This will enhance the understanding of the depositional history of the succession and will improve predictions of facies distributions and potential stratigraphic traps.

Drivers of Base-level change

Three, external (allogenic) factors – tectonics, sea level (eustasy), and climate – have the potential to drive changes in base level as was first described by Barrell (1917) (see also Embry, 2008, in press). An important question regarding the base level history of a given sequence is “Which of the three variables was the main driver of the base-level transit cycle recorded by that sequence?” Climate change tends to result in local, minor base-level changes and is not a viable driver for any sequence of regional extent and / or large magnitude. Consequently this factor is not considered further herein.

Both tectonic activity and eustasy are potentially viable drivers for sequence development at any scale. It is always reasonable to ask if the subaerial unconformities and / or unconformable shoreline ravinements which bound a given sequence on the basin flanks were the product of tectonic uplift followed by collapse or were generated by eustatic fall followed by rise.

The debate of whether tectonics or eustasy is the main driver of the base-level changes recorded by sequence stratigraphic surfaces has been going on since the surfaces were recognized in the 19th century. The debate got quite heated in the 1930s when the origin of Pennsylvanian cyclothems (synonymous with depositional sequences) was considered (Weller, 1930; Wanless and Shepard, 1936). The interpretation that these small-scale, depositional sequences were generated by eustasy driven by the waxing and waning of Gondwana glaciers is now widely accepted (e.g., Heckel, 1986).

Sloss et al. (1949) defined the term sequence for very large-magnitude units with bounding unconformities that stretched over most of the North American continent. Sloss (1963) clearly demonstrated that such unconformities were tectonic in origin. In 1977, when Exxon scientists published their revolutionary papers on seismic / sequence stratigraphy (Vail et al., 1977), eustasy was appealed to as the main factor for generating all sequences, large and small. This interpretation was based mainly on the observations that the same age sequences occurred on different continental margins.

Some researchers now simply assume that eustasy is responsible for all sequence boundaries and have published sea level curves for parts or all of the Phanerozoic on the basis of this assumption and on scattered observations around the world (Haq et al., 1987; Hardenbol et al., 1998; Miller et al., 2005; Haq and Schutter, 2008). The validity of such curves is highly questionable given the great uncertainty of the underlying assumption, not to mention the limited observations. Below, both eustatic and tectonic mechanisms for sequence boundary generation are discussed. Also, suggestions are offered for how one can distinguish a

tectonically generated sequence boundary from a eustatically driven one.

Eustasy

There can no doubt that in some cases eustasy is the main factor in sequence generation. Given that sequence-bounding unconformities are generated over relatively short intervals of time regardless of their magnitude, the only reasonable phenomenon for creating a sequence-bounding unconformity by eustasy is through changes in sea level caused by changes in terrestrial ice volumes. Rates of tectono-eustatic change (changing volume of the ocean basins) are far too slow to generate a sequence boundary.

Ice-volume-related, eustatic changes are well documented and are due mainly to climate cycles driven by changes in orbital parameters, the so-called Milankovitch cycles (Hays et al., 1976). There are three main types of Milankovitch cycles and each has a characteristic periodicity – precession of the equinoxes (~ 20 kyr), axis tilt or obliquity (~ 40 kyr), and orbit eccentricity (100 kyr and 400 kyr). It would appear that such climate-driven cycles have operated on Earth at least from Proterozoic onward (Grotzinger, 1986). Amplitudes of sea level changes associated with these cycles have varied from over 100 metres when extensive glaciers were present in both hemispheres (e.g., Pleistocene) to perhaps 10 metres or less when only mountain glaciers were present (e.g., Devonian). Other climate-related factors, such as temperature-related water volume change and varying, land-based, water storage also contributed to sea level changes but were minor compared to changing ice volumes.

Figure 15.1 (page 72) illustrates the interpreted sea-level changes over the past half-million years based on oxygen isotope data. A base-level transit cycle during this time was about 100 kyr long (eccentricity) and had an amplitude of about 120 metres. Note that a base-level cycle during this time is dominated by a long interval of overall base-level fall which is broken by a few, very short intervals of minor rise. The main interval of base-level rise for each cycle comprises only about 20% of the cycle time and is characterized by relatively high rates



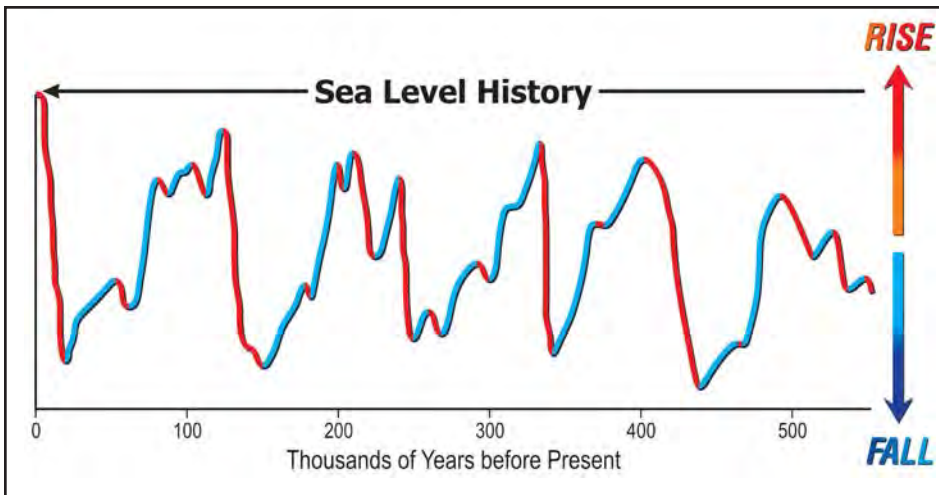

Figure 15.1. Eustatic sea level curve for the past 500 kyr based on oxygen isotopes. The eustatically driven, base-level cycles are about 100 kyr-long and have long intervals of base-level fall and short intervals of rise.

of rise (four times faster than fall rates). The question becomes, “What observable features would be expected to characterize sequence-bounding unconformities generated by eustatically driven base level transit cycles?” First of all, in a downdip direction, the angle between the unconformity and the truncated beds would be very low, being slightly greater than the dip of the sea floor ($< 1^\circ$). On strike, there would be no angularity. Secondly, there would be no change in sedimentary or tectonic regime across such an unconformity although changes in sediment composition might occur, given the possibility of new drainage systems being established.

Furthermore, given the high frequency of the eustatic cycles, sequences would be relatively thin in shelfal areas and numerous, very similar-looking sequences would be stacked upon each other. Finally, one would expect to find the same unconformities on all the basin flanks. In theory, such unconformities would potentially be correlatable worldwide but, as Miall (1991) has elegantly demonstrated, the lack of precision of dating techniques prevents the reliable correlation of high-frequency, eustasy-driven sequence boundaries from one basin to another.

It must be noted that a few authors (e.g., Miller et al., 2003) have postulated that rare intervals of substantial glaciation may have occurred during Greenhouse times (e.g., mid-Permian - Early Paleogene). Such infrequent glacial intervals would be responsible for the occurrence of sporadic unconformities which record base-level falls of up to 60 m. This is an intriguing hypothesis that needs to be properly tested. In these cases, such unconformities would exhibit the first two criteria mentioned above but closely spaced unconformities would not be expected.

There are numerous examples of sequences which exhibit the above characteristics in the literature and their eustatic origin is widely accepted. For the most part, they are high-frequency sequences found in successions deposited during “Icehouse” conditions of the Carboniferous – Early Permian and Late Paleogene – Recent. Parasequences and high-frequency, low-magnitude sequences, which characterize successions deposited during “Greenhouse” intervals also may well be the product of eustasy-driven base-level change as evidenced by their boundary characteristics. However, as demonstrated by Catuneanu et al. (1997), not all high-frequency, low-magnitude sequences are of eustatic origin. Finally, some low-frequency, large-magnitude sequence boundaries in Greenhouse successions may also be of eustatic origin (Miller et al., 2003) but this interpretation is still very much open to debate.

Tectonics

Tectonics also provides a viable mechanism for the generation of sequences. However, unlike eustasy, we don't have a reliable, actualistic curve shape for a tectonically driven, base-level cycle. I suggest that tectonic activity at various scales would be similar to faulting (i.e., fractal relationship) with short intervals of intense activity separated by long intervals of quiescence. Figure 15.2 illustrates a tectonically driven curve based on this model of tectonism. The curve consists predominantly of relatively long intervals of base-level rise (80+% of the time) which characterize the times of relative quiescence. It is punctuated by relatively short intervals of tectonic uplift followed by tectonic collapse which represent the times of greatly increased tectonic activity. Such a model is empirically supported by observations on the stratigraphic geometries of low-order,

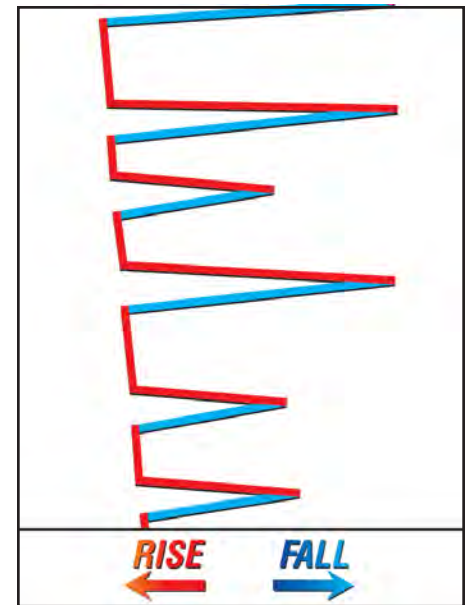

Figure 15.2. A proposed tectonically driven, base-level curve that is characterized by long intervals of slow rise (tectonic quiescence) punctuated by short intervals of rapid base-level fall followed by rapid rise (tectonic uplift and collapse).

Mesozoic sequences of the Sverdrup Basin (Embry, 1990) as well as by the work of (Gawthorpe et al., 1994 and 2003) on fault-driven, base-level changes in rift basins.

Large, low-frequency, tectonically driven, base-level changes would generate widely spaced, large-magnitude (low-order) sequence boundaries overlain by a thin interval of transgressive strata deposited during the collapse phase and overlain by thick intervals of prograding strata deposited during slow base-level rise related to thermally driven subsidence. However, it must be noted, tectonic activity can occur on a variety of scales and thus it is possible for high-frequency, tectonically driven sequence boundaries to be developed in tectonically active settings such as foreland basins (e.g., Catuneanu et al., 1997; Plint, 2000) and rift basins (e.g., Gawthorpe et al., 1994).

Once again, the over-riding question becomes “What are the characteristics of tectonically driven sequence boundaries that would allow them to be reliably distinguished from eustasy-driven ones?” Perhaps the most reliable indicator for recognizing a tectonically generated unconformity is the presence of substantial angularity between the unconformity and underlying sequence stratigraphic surfaces. Figure 15.3 illustrates an outcrop example of such an angular unconformity which was undoubtedly generated by tectonic uplift as opposed to sea level fall. Such angularity beneath an unconformity can be

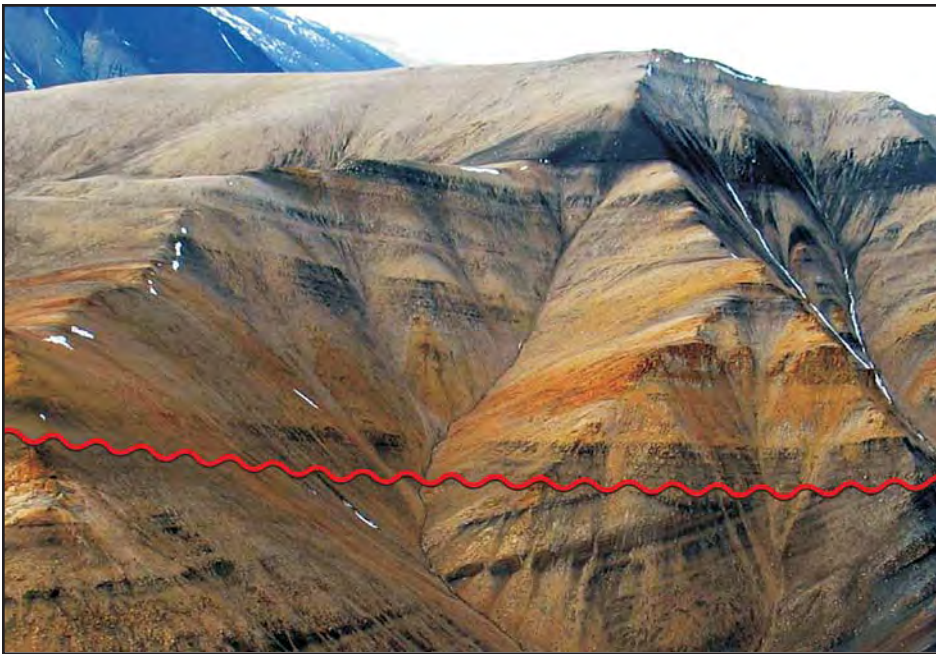

Figure 15.3. A subaerial unconformity (wavy red line) in the Isachsen Formation on western Axel Heiberg Island, Arctic Archipelago. Underlying strata (lower Isachsen Formation, Deer Bay Formation) are truncated at a high angle leaving no doubt as to the tectonic origin of the unconformity.

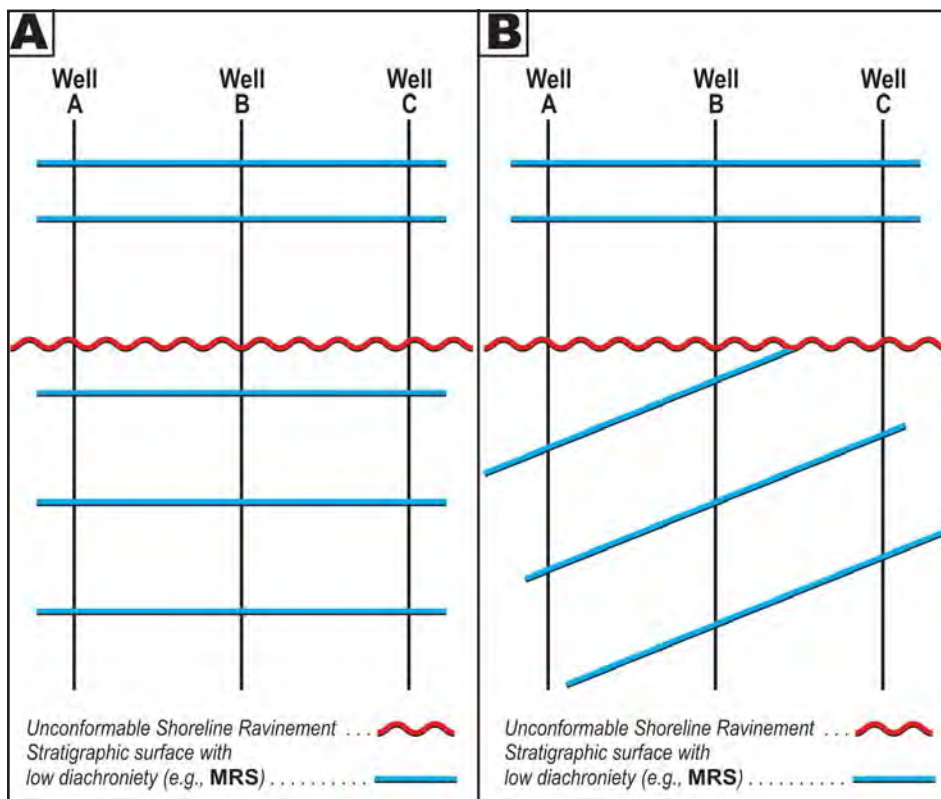

Figure 15.4. The "tilt-test" for an unconformity (Embry, 1997, p.418). Such a stratigraphic geometry test is best done in areas of similar subsidence rate so as to eliminate geometric effects of differential subsidence. A possible eustatically driven unconformity is illustrated in Figure 4A. The sequence stratigraphic surfaces both above and below the unconformity parallel both each other and the unconformity. In this case, base-level fall was equal at all localities which would fit a eustatic origin, although a tectonic one cannot be ruled out. In Figure 15.4B, the stratigraphic surfaces below the unconformity parallel each other (equal subsidence rate) but are at a substantial angle to the unconformity (differential uplift). The stratigraphic surfaces above the unconformity are parallel to the unconformity and to each other (equal subsidence rate restored). Such stratal geometries can only be generated by tectonics and thus the demonstration of such geometries provides excellent evidence for the occurrence of a tectonically generated unconformity (e.g., Figure 15.3).

demonstrated in subsurface successions with seismic and closely spaced well data (e.g., Embry, 1997, Figure 6; Dixon, 2009, Figure 31). In general, anytime an angularity of a few degrees or more can be determined beneath an unconformity (SU, SR-U), especially over an area of little to no differential subsidence, there can be little doubt as to the tectonic origin of the unconformity (Figure 15.4).

Other characteristics of a depositional sequence boundary that indicate it was generated by tectonics are:

- There are major changes in depositional regime across the boundary.
- There are major changes in sediment composition and direction of source areas across the boundary.
- There are significant changes in tectonic regime and subsidence rates across the boundary.

Figure 15.5 (page 74) illustrates Lower to Upper Triassic strata on the flank of the Sverdrup Basin of Arctic Canada. A large magnitude (2nd-order) unconformity separates the Lower and Middle Triassic strata (Embry, 1988 and 1991) and significant changes in both depositional and tectonic regime occur across this boundary. The Lower Triassic succession consists mainly of braided stream strata and was deposited in a high subsidence regime (170 mm/myr). The overlying Middle Triassic strata consist of offshore marine shale and siltstone and were deposited under low subsidence conditions (10 m/myr). The subsidence rate decreased by more than 90% across the unconformity, a clear indication of a tectonic origin for the unconformity.

Figure 15.6 (page 74) illustrates the sequence boundary between Middle Triassic strata below and Upper Triassic strata above. Once again this is a large magnitude boundary (2nd order) and is interpreted to be tectonic in origin in part due to the dramatic shift in depositional regime across the boundary. The Middle Triassic strata consist of siliciclastic sandstone, siltstone, and shale whereas the overlying Upper Triassic strata consist mainly of shelf carbonates. Notably there is also a significant shift in source area across this boundary (Embry, 1988) as well as a notable change in subsidence rate.

Another unconformity of interpreted tectonic origin is illustrated in Figure 15.7 (page 75). It separates Norian (early Late Triassic) strata from Rhaetian (late Late Triassic) strata and there is an abrupt change in sediment composition between the Norian sandstones (quartz, chert, rock fragments) and Rhaetian sandstones (highly



quartzose), Furthermore, up to 500 m of Norian strata are truncated beneath the unconformity in some areas, removing any doubt as to the tectonic origin of the unconformity.

Tectonically generated depositional sequence boundaries have been commonly described in the literature beginning with the continent-wide ones of Sloss (1963, 1988). In general, it appears that most large-magnitude boundaries, which are often assigned to a 1st-, 2nd-, or 3rd-order level in a hierarchy, are tectonic in origin. In almost all cases, they exhibit two or more of the criteria listed for tectonically generated unconformities. As discussed above, smaller magnitude boundaries (4th-, 5th-, and 6th-order) are often of eustatic origin but in some cases are tectonic.

One point of contention has been that some large-magnitude unconformities that have the above-described signature of tectonic boundaries have been interpreted as being eustatic in origin because they are recognized in basins on different continents. For example, the sequence boundary which approximates the Middle / Late Triassic boundary (Figure 15.6) has been recognized in a number of basins around the world and consequently was interpreted to be the product of eustasy (Biddle, 1984). However, there is little doubt that this major sequence boundary is primarily the product of tectonic movements (Embry, 1997). As discussed by Sloss (1991, 1992) and Embry (1990, 1997, 2006), a reasonable case can be made for the generation of similar age, tectonically generated sequence boundaries in basins throughout the world by appealing to plate tectonic mechanisms (see also Collins and Bon, 1996). The bottom line is the boundary characteristic of occurrence in different basins throughout the world is not a valid criterion for differentiating eustatically driven sequence boundaries from tectonically generated ones.

Summary

Either eustasy or tectonics can be the main forcing function for sequence boundary development. Each of these external factors has a characteristic base-level curve shape (Figure 15.8) with tectonics being dominated by slow rise and punctuated by short intervals of rapid fall followed by rapid rise. A eustatic curve is dominated by long, slow falls and short intervals of fast rise. As illustrated on Figure 15.8, the start of base-level rise will nearly coincide with start transgression for both driving factors and thus a eustatically generated sequence boundary will often superficially resemble a tectonically generated one.

However, a eustatically generated sequence

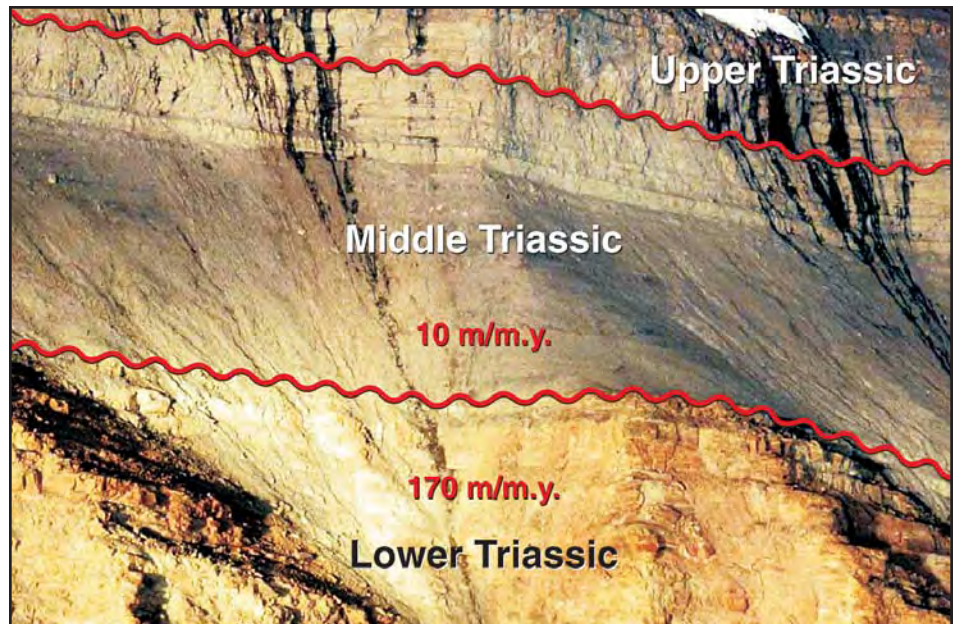

Figure 15.5. Lower to Upper Triassic rocks on the flank of the Sverdrup Basin, Canyon Fiord, Ellesmere Island, Arctic Archipelago. The unconformity (unconformable shoreline ravinement, wavy red line) between the Lower and Middle Triassic successions marks a major change in both subsidence rate and sedimentary regime. These characteristics point to a tectonic origin for the unconformity.

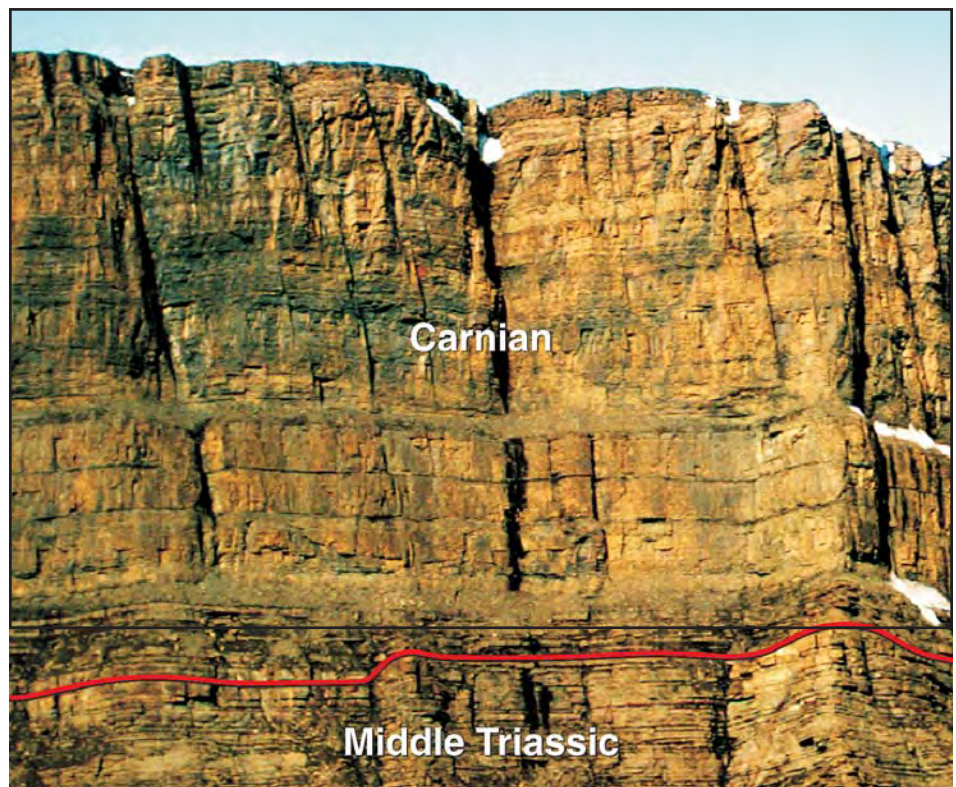

Figure 15.6. Middle Triassic to Upper Triassic (Carnian) strata at Blind Fiord, Ellesmere Island, Arctic Archipelago. A 2nd-order sequence boundary (solid red line), which is a maximum regressive surface at this locality, marks the Middle / Upper Triassic boundary. A major shift in depositional regime from siliciclastics to carbonates occurs across the boundary. A notable change in source area and in subsidence rates also occurs across this boundary. All these features point to a tectonic origin for the sequence boundary.

boundary has a number of different characteristics in comparison to a tectonically driven one. It is most important to determine the degree of angularity beneath a basin-flank unconformity in both

dip and strike directions and to determine the amount of change, if any, in sedimentary regime, tectonic regime and sediment source area across each boundary. With such data, a reasonable and reliable interpretation

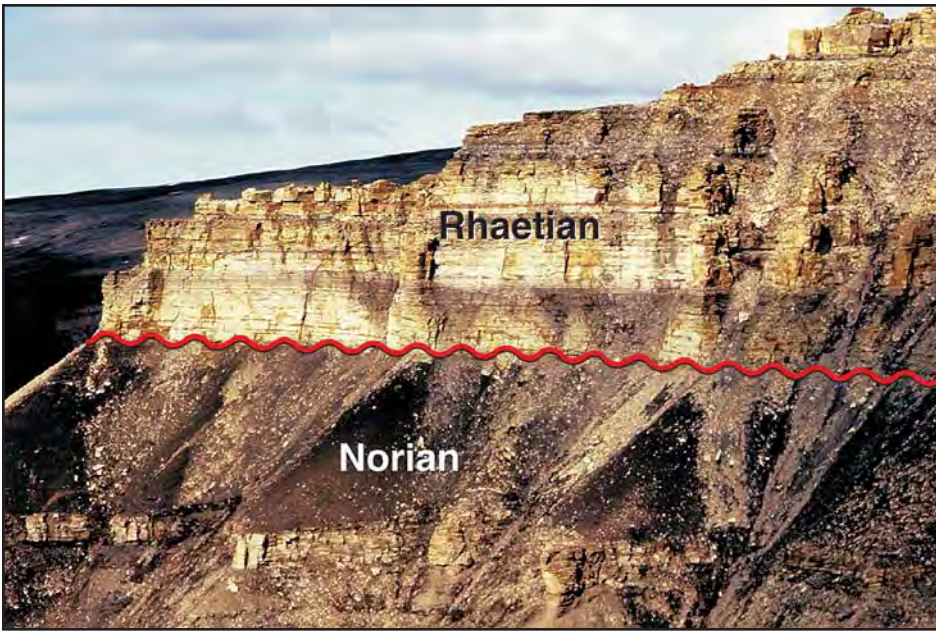

Figure 15.7. A subaerial unconformity separates Norian strata from Rhaetian strata (Late Triassic) on western Raanes Peninsula, Ellesmere Island, Arctic Archipelago. This 1st-order sequence boundary coincides with a significant change in sandstone composition. High-angle truncation is also associated with the boundary on the basin flanks and it is interpreted to be tectonic in origin.

of the origin of a given sequence boundary can be made. Such an interpretation can be useful for predicting facies development, stratigraphic geometries, and potential traps.

Sequence Stratigraphy and Petroleum Exploration

An important task in petroleum exploration is the construction of stratigraphic cross-sections on which correlations are made and facies relationships determined. The success of a play involving the delineation of a stratigraphic trap depends on the reliability of the correlations and the subsequent facies analysis within the framework. As has been demonstrated, sequence stratigraphy involves the recognition and correlation of a variety of stratigraphic surfaces that are used to form an approximate time (chronostratigraphic) framework. These surfaces include subaerial unconformity, unconformable shoreline ravinement, maximum regressive surface, slope onlap surface, and maximum flooding surface (Embry, 2009). A very detailed framework can be constructed with these surfaces, especially when small-scale surfaces are correlated.

A sequence stratigraphic framework is essential to guide facies analysis and one of the key objectives of such analysis is to identify porous facies that may act as petroleum reservoirs. For siliciclastics, such facies are usually sand bodies of nonmarine, shoreline, shallow shelf, and deep marine origin. Each systems tract can be seen as an approximate time stratigraphic unit that contains a variety of facies from nonmarine to deep marine. These will occur in a

predictable lateral and vertical order within the systems tract. For example, if a subaerial unconformity is identified and it rests on offshore marine shale, one can predict that a potentially porous, shoreface sandstone unit lies basinward of that locality at the basinward termination of the unconformity.

Another example would be when an unconformable shoreface ravinement is

identified, it can be concluded that incised valleys that preserve the subaerial unconformity and a section of mainly transgressive, non-marine strata may occur in the area. Incised valleys can contain a variety of porous facies and be completely surrounded by impermeable strata such as offshore shales. Once the facies within an incised valley are documented at one locality, predictions can be made regarding facies changes within the valley succession both landward and seaward of that locality. Of course, major base-level falls that resulted in an exposed shelf edge allow a prediction of the occurrence of sand-prone slope channel fills and submarine fans in the adjacent deepmarine basin area.

Sequence analysis also helps to predict how and where porous strata pinch out laterally. Within a regressive systems tract (RST), a shoreline sandstone unit sometimes disappears landward due to truncation by the sequence bounding unconformity and pinches out basinward due to facies change to impermeable offshore shale and siltstone. Impermeable shelf strata of the overlying transgressive systems tract (TST) of the next sequence can seal such strata. Thus a fairway that has a high potential to contain porous, shoreline sandstone within a given RST can be delineated with the available control. Seismic data can be used to reveal specific prospects along the fairway.

In other cases a shoreline sandstone will pinchout landward due to facies change to impermeable coastal plain facies that can also

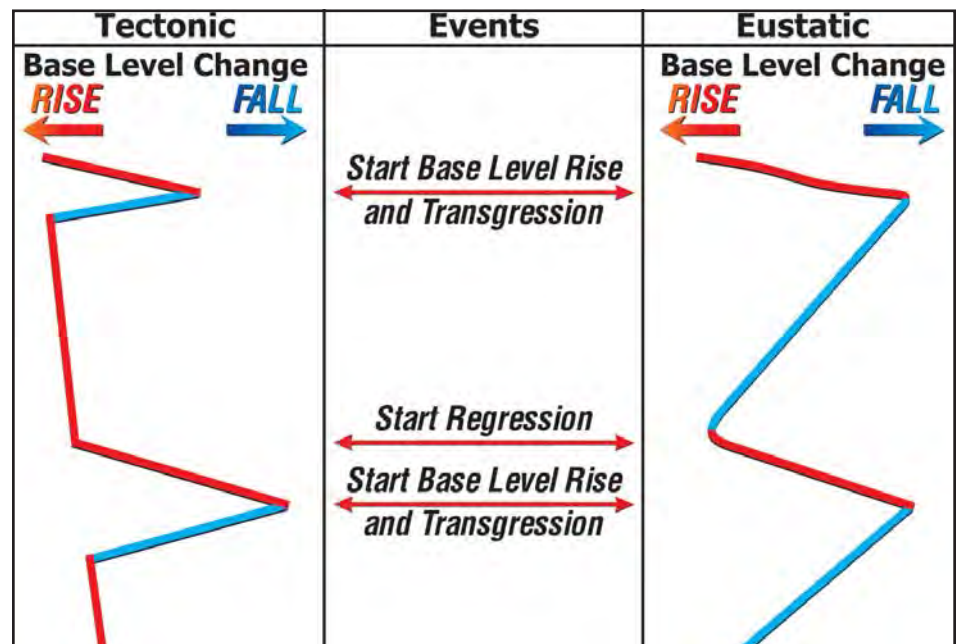

Figure 15.8. A comparison of a tectonically driven baselevel curve (dominated by rise with a short, fast fall) with a eustatically driven one (dominated by fall with a short, fast rise). In both cases the start of base-level rise coincides with the start of transgression because of initial high rates of rise. This results in superficial similarities between sequences generated by tectonics compared with those generated by eustasy. However, the two sequence types can be differentiated on the basis of a variety of specific characteristics (see text).



provide a top seal. Similar fairways of porous, nearshore sandstone can sometimes be delineated for TSTs and, in this case, the sandstone will often pinchout landward due to onlap onto a shoreline ravinement. Such sandstone is usually well sealed by overlying shale and siltstone that were deposited as transgression progressed.

There can be no doubt that the proper interpretation of depositional facies is critical for successful exploration. The same sentiment applies to the surfaces of sequence stratigraphy and an incorrect interpretation of a given surface can lead to misdirected exploration. Often only mechanical logs are available for a sequence interpretation and in this situation an unconformable shoreline ravinement can be easily be mistaken for a maximum regressive surface and viceversa. On a gamma log, both surfaces are drawn at the change from a shallow marine, coarsening-upward succession (RST) to a shallow marine, fining-upward one (TST). If the underlying coarsening-upward succession terminates in shaly, mid-shelf sandstone, the explorationist would naturally want to locate potentially porous, shoreface sandstone in that RST. If the surface encountered in the control point is a maximum regressive surface, then a shoreface sandstone unit would occur landward of the control well. However, if the surface is an unconformable shoreline ravinement then the shoreface sandstone unit would occur basinward of the control well, in exactly the opposite direction as was dictated by the MRS interpretation. As illustrated by this example, the correct interpretation of sequence stratigraphic surfaces is critical for exploration success.

Concluding Remarks

This article wraps up the Practical Sequence Stratigraphy series, which has covered the main topics of sequence stratigraphy including historical development, the surfaces of sequence stratigraphy, the linkage between base level and sequence stratigraphic surfaces, the units of sequence stratigraphy, and more general topics of sequence hierarchies, correlation, and sequence boundary origin.

Sequence stratigraphic analysis is a core methodology in petroleum exploration. If it is applied in an objective, pragmatic manner with the use of a material-based surfaces and units, it can greatly enhance petroleum exploration and exploitation. The method involves:

- Identification of sequence stratigraphic surfaces in a succession,
- Correlation of the surfaces over the study area,

- Determination of the facies distribution within the sequence stratigraphic framework,
- Interpretation of the depositional history of the succession in terms of tectonic and/or eustatic base-level changes,
- Construction of facies maps at both the approximate time of maximum regressive and the approximate time of maximum transgression for each sequence.

With the adoption of this methodology, sequence stratigraphy becomes a valuable addition to the explorationist's tool kit.

References

Barrell, J. 1917. Rhythms and the measurements of geologic time. *GSA Bulletin*, v. 28, p. 745-904.

Biddle, K. 1984. Triassic sea level change and the Ladinian- Carnian stage boundary *Nature*, v. 308, p. 631-633.

Catuneanu, O., Sweet, A., and Miall, A. 1997. Reciprocal architecture of Bearpaw-T-R sequences, uppermost Cretaceous, Western Canada Sedimentary Basin. *Bulletin Canadian Petroleum Geology*, v. 45, p. 75-94.

Collins, J. F. and Bon, J. 1996. Mantle origin of global sealevel fluctuations and geomagnetic reversals: evidence from non-linear dynamics. In: C. Caughey et al. (eds.), *International Symposium on Sequence Stratigraphy in SE Asia*. Indonesian Petroleum Society, p. 91-128.

Dixon, J. 2009. Triassic stratigraphy in the subsurface of the plains area of Dawson Creek (93P) and Charlie Lake (94A) map areas, northeast British Columbia. *Geological Survey of Canada, Bulletin 595*, 78 p.

Embry, A. F. 1988. Triassic sea-level changes: evidence from the Canadian Arctic Archipelago. In: C. Wilgus, B. Hastings, C. Kendall, H. Posamentier, C. Ross, and J. Van Wagoner (eds.), *Sea-level changes – an integrated approach*. *SEPM Special Publication 42*, p. 249-259.

Embry, A. F. 1990. A tectonic origin for third-order depositional sequences in extensional basins implications for basin modeling. In: T. Cross (ed.), *Quantitative Dynamic Stratigraphy*. Prentice Hall, p. 491-502.

Embry, A. F. 1991. Mesozoic history of the Arctic Islands. In: H. Trettin, (ed.), *Innuitian Orogen and Arctic Platform: Canada and Greenland: Geological Survey of Canada, Geology of Canada No. 3 (also GSA, The Geology of North America, v. E)*, p. 369-433.

Embry, A. F. 1997. Global sequence boundaries of the Triassic and their recognition in the Western Canada Sedimentary Basin. *Bulletin Canadian*

Petroleum Geology, v. 45, p. 415- 433.

Embry, A. F. 2006. Episodic Global Tectonics: Sequence Stratigraphy Meets Plate Tectonics. *GEO Expo*, v. 3, p. 26- 30.

Embry, A. F. 2008. Practical Sequence Stratigraphy VII: The base-level change model for material-based sequence stratigraphic surfaces. *Canadian Society of Petroleum Geologists, Reservoir*, v. 35, issue 11, p. 31-37.

Embry, A. F. 2009. Practical Sequence Stratigraphy XIV: Correlation. *Canadian Society of Petroleum Geologists Reservoir*, v. 36, issue 7, p 14-19.

Embry, A. F. In press. Correlating Siliciclastic Successions with Sequence Stratigraphy. In: K. Ratcliffe and B. Zaitlin, (eds.), *Application of Modern Stratigraphic Techniques: Theory and Case Histories*, *SEPM Special Publication 94*.

Gawthorpe, R., Fraser, A., and Collier, R. 1994. Sequence stratigraphy in active extensional basins: implications for the interpretation of ancient basin fills. *Marine and Petroleum Geology*, v. 11, p. 642-658.

Gawthorpe, R., Hardy, S., and Ritchie, B. 2003. Numerical modeling of depositional sequences in half-graben rift basins. *Sedimentology*, v. 50, p. 169-185.

Grotzinger, J. 1986. Upward shallowing platform cycles: a response to 2.2 billion years of low-amplitude, high-frequency (Milankovitch band) sea level oscillations. *Paleoceanography*, v. 1, p. 403-416.

Hardenbol, J., Thierry, J., Farley, M., Jacquin, T., De Graciansky, P. and Vail, P. 1998. Mesozoic and Cenozoic Sequence Chronostratigraphic Framework of European Basins. In: P.C. de Graciansky, J. Hardenbol, T. Jacquin, and P. Vail (eds.), *Mesozoic and Cenozoic sequence stratigraphy of European basins*, *SEPM Special Publication 60*, p. 3-14.

Haq, B., Hardenbol, J., Vail, P. 1987. Chronology of fluctuating sea levels since the Triassic (250 million years ago to present). *Science*, v. 235, p. 1156-1167.

Haq, B and Schutter, S. 2008. A Chronology of Paleozoic Sea-Level Changes. *Science*, v. 322. p. 64-68.

Hays, J., Imbrie J., and Shackleton, N. 1976. Variations in the Earth's Orbit: Pacemaker of the Ice Ages. *Science*, v. 194. p. 1121-1132.

Heckel, P. 1986. Sea-level curve for Pennsylvanian eustatic marine transgressive-regressive depositional cycles along midcontinent outcrop belt, North America. *Geology*, v. 14, p. 330-334.

Miall, A. 1991. Stratigraphic sequences and their chronostratigraphic correlation. *Journal of*



Sedimentary Research, v. 61, p. 497-505.

Miller K., et al. 2003. Late Cretaceous chronology of large, rapid, sea-level changes: Glacioeustasy during the greenhouse world. *Geology*. v. 31, p. 585-588.

Miller, K., et al. 2005. The Phanerozoic Record of Global Sea-Level Change. *Science*, v. 310, p. 1293-1298.

Plint, A. 2000. Sequence stratigraphy and paleogeography of a Cenomanian deltaic complex: the Dunvegan and lower Kaskapau formations in subsurface and outcrop, Alberta and British Columbia, Canada. *Bulletin Canadian Petroleum Geology*, v. 48, p. 43-79.

Sloss, L. 1963. Sequences in the cratonic interior of North America. *GSA Bulletin*, v. 74, p. 93-113.

Sloss L. 1988. Tectonic evolution of the craton in Phanerozoic time. In: L. Sloss (ed.), *Sedimentary Cover – North American Craton: U.S. The Geology of North America, D2*, Geological Society of America, p. 25-51.

Sloss L. 1991. The tectonic factor in sea level change: a countervailing view. *Journal Geophysical Research*, v. 96, p. 6609-6617.

Sloss L. 1992. Tectonic episodes of cratons: conflicting North American concepts. *Terra Nova*, v. 4, p. 320-328.

Sloss, L., Krumbein, W., and Dapples, E. 1949. Integrated facies analysis. In: C. Longwell, (ed.). *Sedimentary facies in geologic history*. Geological Society America, *Memoir 39*, p. 91-124.

Vail, P. et al. 1977. Seismic stratigraphy and global changes in sea level. In: C. Payton, (ed.), *Seismic stratigraphy: applications to hydrocarbon exploration*, AAPG *Memoir 26*, p. 49-212.

Wanless, H. and Shepard, F. 1936. Sea level and climatic changes related to late Paleozoic cycles. *GSA Bulletin*, v. 47, p. 1177-1206.

Weller, J. M. 1930. Cyclic sedimentation of the Pennsylvanian period and its significance. *Journal of Geology*, v. 38, p. 97-135.

