

ACTION AS COUNTERCHANGE: IDENTIFYING ANTECEDENTS OF THE DOMAIN AND GOAL OF ACTION

Geraldine Fennell, Consultant

Abstract

As psychologists become involved professionally in the activities of everyday lives, the discipline's lack of a comprehensive model of action is beginning to be acknowledged. Assigned the job of helping producers make goods/services appropriate to user-circumstances, marketers especially feel the lack of a general model of action. Earlier approaches to modeling action are here reviewed. Extensions are offered and directions for further research are indicated.

Introduction

A salutary message may finally be delivered to mainstream psychology and from an unexpected quarter. Changes in technological capability are leading to changes in the nature of goods/services. From supplementing or replacing the work of human muscles, goods/services increasingly share the work of human minds. Psychologists whose interests span the worlds of scholarship and practice may find that mainstream psychology lacks conceptualizations that are cast appropriately for guiding the work of producers. In the context of his interest in user-machine interfaces, Norman (1986, p. 37) remarks on the lack of work in psychology relative to "how people actually do things, which means a theory of action." Searching the earlier literature for what is relevant to his concerns, he finds only Miller, Galanter, and Pribram (1960), Powers (1973), and Card, Moran, and Newell (1983). Similarly, as marketers viewing psychology from the perspective of those who guide producers of goods/services, we keenly feel psychology's inadequacies when we must conceptualize and describe the contexts for everyday activity.

The task for psychological science is not an easy one, as the following thought experiment may show. Consider any human action and compare two things: (1) What is objectively observable—available to the senses of individuals other than the actor, directly or through instruments, and (2) What the action means to the actor. For example, as regards dictating a letter, accepting an award, visiting a sick friend, attending live theater, feeding a baby, or sipping a cup of tea, consider, on the one hand, what is observable and, on the other, (a) What the actor may be experiencing and (b) The range of all experiencings of such an action. If ever an aspect of the natural world called for the scientist's creative representational skills, it is surely the phenomenon of human action.

Herein, I discuss some conceptual issues that need to be addressed in modeling action. First I briefly review the conceptualizations of other authors, including that of Norman (1986) and the authors he mentions, as noted above. Then I discuss extending conceptualizing upstream from the point where theorists have been focusing so that we may have a model that helps producers approach their task systematically.

Toward a Model of Action

With their TOTE (Test-Operate-Test-Exit) unit, Miller,

Galanter, and Pribram (1960) substitute a feedback loop for the classic reflex as the behavioral element of interest. As they say (pp. 26-27), "action is initiated by an 'incongruity' between the state of the organism and the state that is being tested, for, and the action persists until the incongruity" (i.e., the proximal stimulus) is removed. The general pattern of reflex action, therefore, is to test the input energies against some criteria established in the organism, to respond if the result of the test is to show an incongruity, and to continue to respond until the incongruity vanishes, at which time the reflex is terminated. Thus, there is 'feedback' from the result of the action to the testing phase, and we are confronted by a recursive loop. The simplest kind of diagram to represent this conception of reflex action—an alternative to the classical reflex arc—would have to look something like Figure 1...The interpretation toward which the argument moves is one that has been called the 'cybernetic hypothesis' namely, that the fundamental building block of the nervous system is the feedback loop (Wiener 1948, Wisdom 1951, Sluckin 1954)."

FIGURE 1 A TOTE UNIT



What is being modeled here is a process that maintains the value of some variable within an acceptable range. Alternatively, the operations an organism performs are constantly guided by the outcomes of various tests (p. 29). Other authors have developed models along lines similar to TOTE but including greater detail in some respects. Three such models are reproduced in the Appendix. Each represents a process by which an individual may reduce/eliminate the difference between two states, that is, a present and a nonpresent or imagined state—a goal, which an individual may bring about by performing some environmental adjustment. Each author envisions an individual who makes some adjustment and, upon checking the outcome and ascertaining that the goal has not been achieved, continues adjusting. In Pask's model (Figure A-1), the individual continues until the difference between the present and anticipated state or goal is zero, or the limit of available effort has been reached. In Powers' model

¹ Except Card et al. (1983), with whom Norman claims close kinship for his model, replaced here by Pask (e.g., 1970).

² Miller et al. (1960) say "incongruity," to avoid having to distinguish between TOTES in which detecting a difference/no difference "releases" the operations (p. 31). Equating "incongruity" and "proximal stimulus," as here, may evoke a drive-reductionist view. In any event, so doing deflects attention from considering the separate elements that constitute a "test."

FIGURE 3 ADJUSTMENTS INDIVIDUALS MAKE

BEYOND THE REACH OF BEHAVIORAL CONTROL	POTENTIALLY UNDER BEHAVIORAL CONTROL	
	OCCASIONS OCCUR UNPREDICTABLY	OCCASIONS OCCUR PREDICTABLY
	Activating Change	Automatized Routines

An appropriate broader context is one in which we regard action as a means of effecting the numerous adjustments that living organisms make throughout a lifetime. An individual consists of, and participates in, numerous systems. Among the many adjustments that individuals make, some are automatic in the sense of being inaccessible to an individual's behavioral processes of control (Figure 3). Others are under behavioral control, which means that adjustments in the values of variables result from changes that involve, actually or potentially, an individual's focal attention. Elsewhere (Fennell 1987), I have characterized the circumstances that allocate an individual's behavioral resources as occurring either nonpredictably ("Activating Change" e.g., one becomes aware of feeling hungry and considers eating), or regularly ("Automatized Routines" e.g., eating at regular intervals). My main interest here is modeling the first of these, which I conceptualize as a behavioral episode that, broadly described, consists of change, attempted counterchange, and learning (Figure 4). The second, or regularly-occurring case, is essentially a streamlined version of a behavioral episode, many elements of which drop out as action becomes automatized.

FIGURE 4 BEHAVIORAL EPISODE

CHANGE COUNTERCHANGE (?) LEARNING

For a start, an individual's resources are always allocated to one substantive domain or another. A theorist must select some point to enter such a behavioral stream and here that point is events associated with change. Some aspect of the relation between individual and environment changes, intruding the fact of such change into an individual's focal attention. As experienced, change may take the form of an individual's coming to realize that some information has personal significance, or that s/he feels uncomfortable and is searching for the reason. The individual finds his or her resources allocated to dealing with this interrupting event—to effecting counterchange—either by reappraising the precipitating events, or by searching for and trying to effect some environmental adjustment. Whether or not such an attempt is successful, the incident leaves a record in the form of learning.

Later I give more details about the events just described. For now, I have said enough to begin to show how the present differs from other approaches, taking the TOTE unit for detailed comparison here. A behavioral episode begins when a "test," conducted preattentively, yields a result that compels focal attention. TOTE may be compared with a behavioral episode in one of two ways. As shown in Figure 5a, a TOTE unit may be considered to commence outside the individual's consciousness, which is engaged only when the out-

(Figure A-2), the individual continues adjusting until the present value of some variable equals a reference value. In Norman's model (Figure A-3), the individual perceives, interprets, and evaluates the outcome of an act in relation to the intended goal state. Going beyond TOTE and Pask's model, Powers includes a rudimentary representation of perturbing events (i.e., "proximal" and "remote" physical phenomena), and Norman includes a more detailed analysis of the cognitive context immediately before and after action. All assume a particular goal and domain of action as given. None models the process by which an individual's resources are directed to one among many possible goals and domains of action. None addresses how events upstream from the point at which a variable departs from its reference level (or a difference occurs between a present and an imagined state) select the particular domain of adjustment in any instance. The models are not designed to answer questions such as: How is it that an individual is hammering a nail to make its head flush with the surrounding surface (TOTE), playing a complex laboratory game (Pask), tracking a spot of light (Powers), or trying to use a computer (Norman)? Each author studies the course of action where action domain and goal are given. In contrast, of interest here are events upstream that select a substantive domain for possible adjusting and the goal of adjusting.

Moreover, TOTE and the other three models represent action during that portion of its natural history when the actor may be assumed to engage in performing some task consciously or intentionally. A significant aspect of the context for action comprises the process by which an individual's behavioral resources including, potentially, focal attention come to be allocated to specific substantive domains. Accordingly, I am interested in the conditions under which a substantive domain enters focal attention for possible adjusting.

Representing the Context for Acting

From the perspective of one who would guide producers of goods/services, it is necessary to locate action in some conceptual context. This is because once the test-retest criterion, or the goal, or the action domain are specified, we are already some distance along in regard to what an individual is doing. Consider where a good/service belongs in a TOTE unit. As shown in Figure 2, its place is in the operate phase. Goods/services help individuals to make some adjustment—do something to the criterion of the TEST. If they are to design appropriate aids for the OPERATE phase, producers must understand the domain of TEST. As advisers to those who would make the goods/services that help individuals accomplish their purposes, marketers must conceptualize and describe the events that allocate individuals' resources to particular goals.

FIGURE 2 A TOTE UNIT: PRODUCER'S PERSPECTIVE

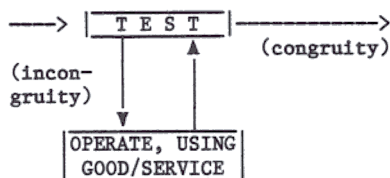

3 Powers and Miller et al. use "proximal" differently.

FIGURE 5 TOTE AND BEHAVIORAL EPISODE COMPARED

TOTE (a)	BEHAVIORAL EPISODE	TOTE (b)
TEST—incongruous OPERATE	CHANGE COUNTERCHANGE(?)	TEST—incongruous OPERATE
TEST—incongruous OPERATE		TEST—congruous EXIT
TEST—congruous EXIT	LEARNING	

come is incongruous. Alternatively, (Figure 5b) TOTE may be considered to commence when an individual is already aware that some incongruity must be addressed, knows the nature of the incongruity—of the test criterion—and ways to address it, has selected an operation by which to do so, and is performing that operation and checking its outcome against the criterion. As noted, the examples that Miller et al. (1960), Pask & Von Foerster (1961), Powers (1973) and Norman (1986) use suggest that they have in mind the stage of a behavioral episode that is represented in Figure 5b.

At a more general level, Miller et al. (1960) distinguish the domains of Image (all the accumulated, organized knowledge that the organism has about itself and its world, including everything the organism has learned—values as well as facts—organized by whatever concepts, images, or relations s/he has been able to master, pp. 17-18), and Plan (any hierarchical process in the organism that can control the order in which a sequence of operations is to be performed, p. 16). They believe that sometimes what matters is constructing a better Image, sometimes it is elaborating a better Plan. Considering TOTE appropriate for discussing both Image and Plan, the authors choose to focus on Plan (p. 175). In contrast, I consider that we may begin to understand action only when, integrating the elements that constitute "image" and "plan," we represent specific contexts in which action may occur.

Perhaps the best way to show needed extensions to the TOTE approach is to modify TOTE along the lines of Figure 5a, adding some of the detail with which I have described events in a behavioral episode (e.g., Fennell 1987). As shown in Figure 6, at issue is a cognitive or sensory variable within an individual's domain of sensitivity, e.g., skin temperature (S_3). Certain values of such variables start a behavioral process that may restore the variable to equilibrational values. Within some range of its values, the variable is quiescent. Outside that equilibrational range, an "incongruous" state exists. The TOTE model suggests that an individual continuously tests the values of all variables in domains of sensitivity. An alternative, perhaps more plausible, notion is that, when they occur, values outside the equilibrational range ("No" in Figure 6) set in motion a physical process that signals such departure. "Antecedent influences" affect the values of variables in domains of sensitivity. e.g., air temperature, for the present example of skin temperature.

When the value of a variable is outside its equilibrational range, a change in affect engages focal attention. From pleasant or neutral, affect changes to unpleasant with a minimal cognitive element signaling, Attend!

The individual must identify the substantive domain that is implicated e.g., body too cold, and identify a behavioral objective which, if satisfied, may render

the variable quiescent, in the present instance, "become warmer." The "test criterion," C_{S_3} , must be appropriate to the perturbing events, i.e., reflect the substantive domain and kind of adjusting called for. The individual must be able to generate possibilities for making such an adjustment—in principle, e.g., putting on more clothing/blankets, and in the immediate environment e.g., items of extra clothing that are readily accessible. Among candidate items i.e., those offering the essential characteristic of warm-making, some may also entail undesirable side effects or, more generally, costs. When an individual has selected the best among the available candidates, the question remains: Is effecting the proposed counterchange likely to be worth the cost of doing so? Am I cold enough to warrant the bother of disentangling myself from my chair to fetch the sweater I believe is hanging in my closet across the room? Should it pass this test, the individual attempts to act—"operate" (A_{S_3}) in Figure 6. The attempted action—here, putting on a particular sweater—may fail. For example, as I look in the closet, the sweater may be missing or, as I take it down, it may come apart in my hands. Depending on how one's attempted operation fails to achieve the criterion (here, warm-making), the individual reverts to an appropriate earlier stage and proceeds as before. Should one find the sweater as expected and put it on, affect may return to neutral or pleasant. Focal attention is no longer engaged. Hopeful during attempted counterchange, an individual may experience a temporary change in the equilibrational range such that adjacent values previously outside may be assimilated.

Should the action affect the relevant antecedent condition appropriately (air temperature near the skin),

FIGURE 6 MODIFIED TOTE UNIT

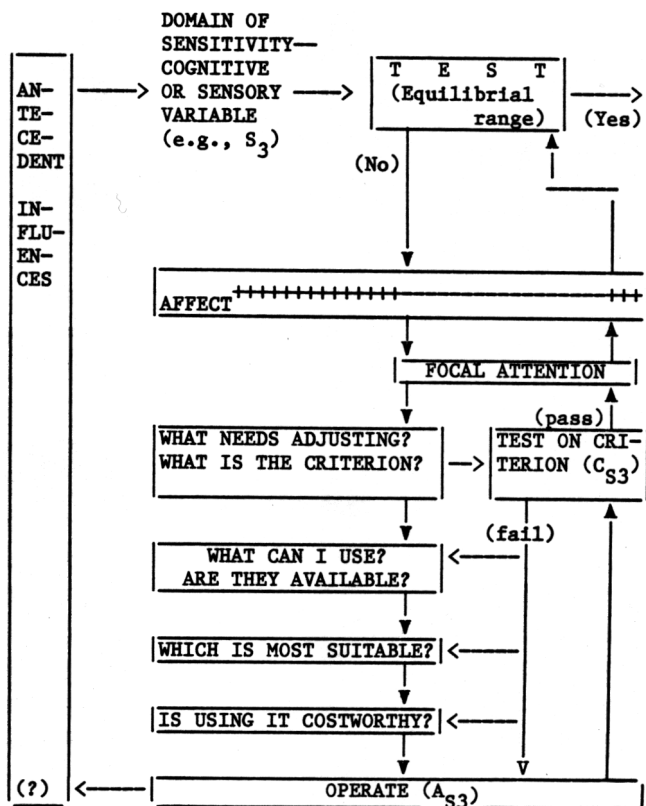

the domain of sensitivity is no longer activated (the variable is no longer outside its equilibrium range). Otherwise, after the grace period during which adjacent values are assimilated, the process starts again.

Some ways in which modified TOTE differs from the original are: 1) In Figure 6, the original TOTE (construed as in Figure 5b) begins at Test on Criterion (C_{33}), where the questions, What needs adjusting? and What is the criterion? have been answered. 2) Upstream from that point, the additional elements in modified TOTE are included to represent how an individual's resources are allocated to a particular substantive domain, i.e., how substantive domains come up for possible adjusting, and the goal of adjusting. 3) Downstream from that point, the additional elements in modified TOTE are included to represent aspects of using one's resources appropriately, including selecting an appropriate operation (A_{33}). Next, we discuss such considerations in the context of a behavioral episode.

Representing a Behavioral Episode

The nature of the producer's task requires that a theorist first represent a behavioral episode as it might occur in the absence of any intervention (Figure 7), and then, in a companion figure (Figure 14), show how a producer would use the basic model in planning to help an individual make some counterchange. As noted, in modifying TOTE, where time is shown on the horizontal axis (Figure 6), I drew on my concept of a behavioral episode, which is represented in Figure 7 (time on the vertical axis). Aspects of my model that are broadly comparable to other approaches will not detain us here. "Desired states," for example, roughly corresponds to "test criterion" (reference level, goal) in the models discussed earlier. Moreover, consumer psychologists may see some similarity between "Desired States," and choice criteria or product benefits, and between "Beliefs" and brand perceptions. Space is better used to discuss the qualitative relationship of action to its antecedents, a topic on which other models are silent. Accordingly, in focus here are events

FIGURE 8 VARIABLES IMPLICATED IN ALLOCATING RESOURCES

ANTECEDENT CONDITIONS		DOMAINS OF SENSITIVITY
LEVEL TWO	LEVEL ONE	
Determine values of variables at Level One	Immediately determine the status of variables in domains of sensitivity	Sensory and cognitive variables certain values of which start a behavioral episode i.e., compel an individual to allocate resources

upstream from "desired states" i.e., change, and their significance in selecting the substantive domain and goal of (appropriate) action i.e., counterchange.

Nature of Change

The concept of sensitive domains reflects the fact that only some stimuli to which an individual is exposed compel an allocation of the individual's resources. Dog whistles, and names of celebrities in unfamiliar fields are examples of stimuli to which an individual is insensitive. Domains of sensitivity comprise cognitive and sensory variables ($S_{1,...n}$), certain values of which compel an individual to allocate resources. Two relevant levels of antecedent condition are: Level One—variables that immediately affect the status of variables in sensitive domains, and Level Two—variables that, in regard to a focal episode, affect the individual only indirectly i.e., through their effect on values of variables at Level One (Figure 8). Variables at levels one and two may be personal or environmental. Elsewhere (Fennell 1978, 1980), I have described qualitatively different kinds of change.

Consider, for example, individuals who become aware of the sensation that their body is cold (sensory variable). Level one elements include air temperature adjacent to the skin, and equilibrium values of skin temperature; Level two include weather conditions and provisions the individuals made for shelter. Or consider individuals who, learning they are in the path

FIGURE 7 BEHAVIORAL EPISODE

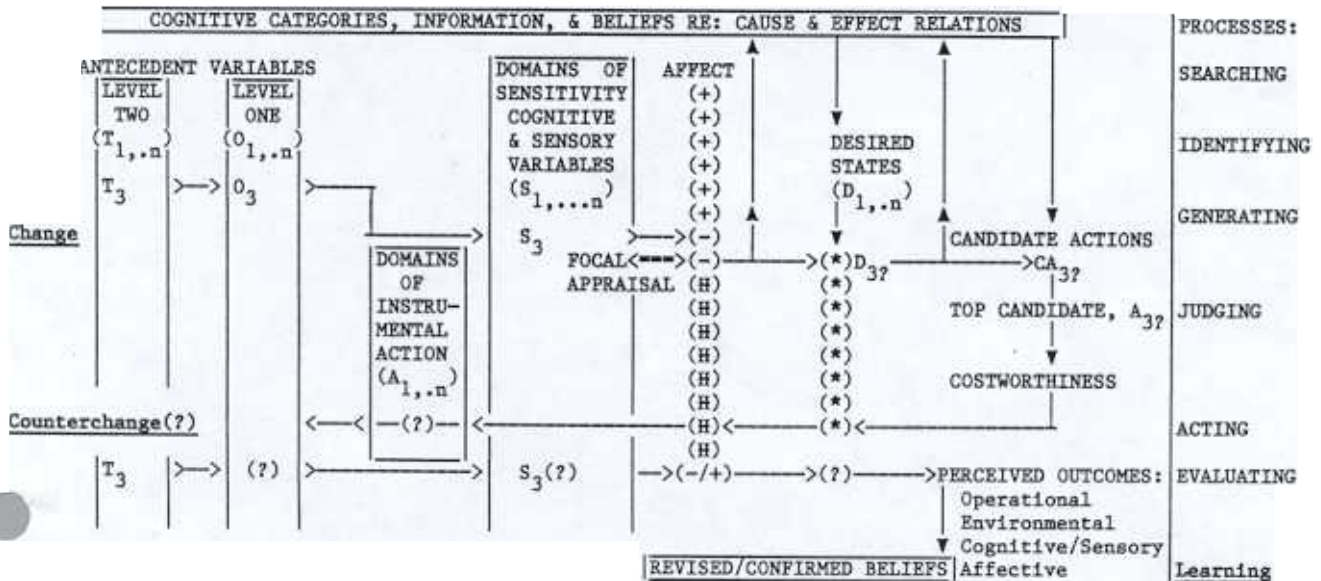

FIGURE 9 EXAMPLES OF ELEMENTS IMPLICATED IN CHANGE

LEVEL TWO	LEVEL ONE	SENSITIVE DOMAIN
Weather conditions and provision made for shelter	Air temperature at skin; equilibrium values of skin temperature	Sensory, e.g., Sensations of cold
Forecasting system, atmospheric conditions	Message of reliable weather forecaster	Cognitive, e.g., Danger is present

of a hurricane that is close, understand they are in danger (cognitive variable). Level one elements include components of the message such as perceived reliability of the forecaster, closeness and strength of the storm; Level two include the weather forecasting system and atmospheric conditions (Figure 9).

Nature of Counterchange

Change occurs when values of Level One variables are such as to cause variables in domains of sensitivity to assume values outside their equilibrium range. An individual is alerted to the fact that change has occurred by experiencing a characteristic affective quality—an insistent unpleasantness, with accompanying cognitive message: Attend! Once an individual's resources are directed to the possibility that some adjustment is needed, s/he may use focal attention to appraise the situation. The outcome may be a decision that no further allocation of resources is required. The behavioral episode terminates. Otherwise, a desired state exists in principle (D_3), i.e., some state that lacks whatever has initiated the behavioral episode. The individual wishes the present state were other than it is. To effect counterchange, s/he must know which sensitive domain (S_3) has been perturbed, i.e., is outside its equilibrium range, or, minimally, which kinds of actions (CA_3) are likely to render it

quiescent. Searching the current environment and memory for relevant information, the individual engages in cognitive acts such as identifying the essential characteristics of desired states, generating candidate actions, i.e., what to do to bring about the desired states, and what it is possible to do in the present instance, judging the relative strengths/weaknesses of candidates, if more than one, and the cost-worthiness of the sole or top candidate. As an individual engages in trying to effect counterchange, hope mutes the feeling of discomfort.

Attempts to effect counterchange may have a variety of outcomes. It may be impossible to perform the selected act because the environment is not as the individual believed it to be. (The sweater is not in the closet). In such a case, the decisional process reverts to some appropriate earlier stage and continues as before. Or, putting on the sweater, after a little while the cycle may start again because the sweater is inadequate. Or, putting on the sweater and becoming warmer, after a little while the individual may again experience activating discomfort and realize that s/he misdiagnosed the problem—the sensation first interpreted as "being cold" was due less to air temperature than to nagging anxiety about an unresolved problem.

The episode's outcome, of whatever kind, is recorded in memory, resulting in confirming or revising the individual's beliefs about ways to effect counterchange in similar circumstances or in general. Once the individual tries to effect counterchange, hope is replaced by some other emotion that reflects feedback from reality, potentially spanning a wide range and, depending on the nature of the individual's expectations and the outcomes actually experienced, including disappointment, happiness, surprise, and others.

Let us consider the adjustive aspects of counterchange—the four elements shown in Figure 10: two classes of antecedent events i.e., Level Two and Level One variables, and two aspects of behavioral control i.e., domains of sensitivity and of instrumental action.

FIGURE 10 COUNTERCHANGE AS ADJUSTING

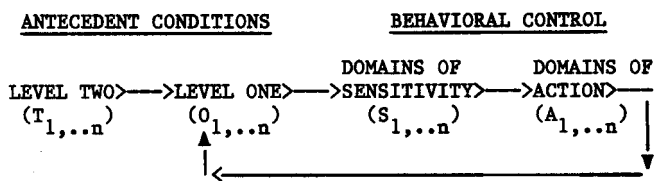

Specific Instance:

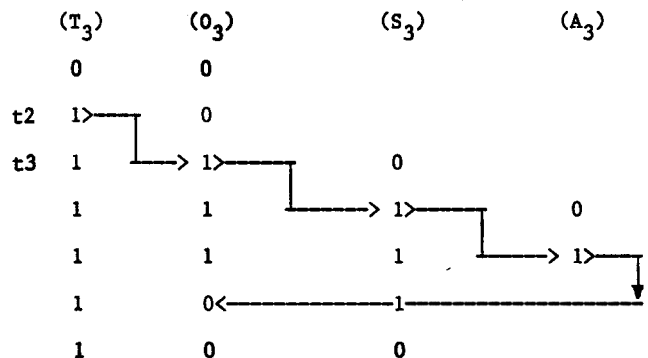

Events at Level One, e.g., a drop in air temperature combined with certain equilibrium values for skin temperature, causes a sensitive domain to react (sensation of being cold), starting a process whose outcome may be that the individual acts (puts on additional clothing), changing the value of a Level One variable. If an individual correctly identifies and changes Level One variables (or desired states and action are chosen appropriately), the sensitive domain no longer reacts. The particular behavioral episode is over. Individuals may be able to affect events at Level Two

FIGURE 11 ACTION IMPLICATIONS OF CHANGE VARIABLES

ANTECEDENT CONDITIONS LEVEL TWO	LEVEL ONE	DOMAINS OF SENSITIVITY
Determine values of variables at Level One. May be accessible to individual's influence, if at all, only by foresight &/or collaboratively.	Immediately determine status of variables in domains of sensitivity. Immediately accessible to influence by individual via action.	Sensory and cognitive variables, certain values of which start a behavioral process that may adjust values at Level One, and thus render sensitive domains quiescent.

FIGURE 12 EXAMPLES OF RESOURCE-ALLOCATION & USE

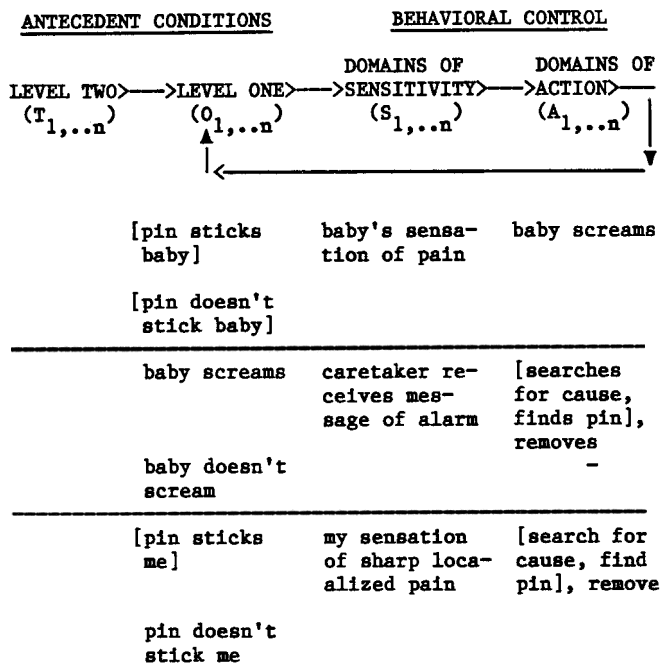

e.g., change in atmospheric conditions, failure of fuel to arrive, but if so, it is through foresight and planning and possibly by collaborating with others. Accordingly, within the context of any particular activation of a sensitive domain, acting to affect Level Two variables is not a relevant option (Figure 11).

An experiencing individual, or an observer, may not be cognizant of operative events in one or more of the four classes. This ambiguity in a behavioral episode is many-faceted and probably accounts for the apparent intractability of action as a subject of formal study. Simple instances of the problem are illustrated in Figure 12, where aspects that are not readily accessible to actor/observer are enclosed in square brackets.

Note that the infant's crying out in reaction to a pin prick may function as an instrumental action, if a caretaker is within earshot. To a caretaker, however, the infant's cry conveys only general information, and s/he must search for and identify a likely Level One

variable (the pin, in the present example). A Level Two approach to the problem is to do away with one major source of pins in infants' clothing by using a pinless fastening as in disposable diapers.

Similarly, even in the case of an adult who feels a sharp localized pain, Level One variables may not be immediately known. Individuals may err in identifying the operative Level One variable—in the present case, for example, s/he may erroneously attribute the sensation to a sharp grain of sand found in the general region of the pain. Brushing off the grain without experiencing relief, the individual continues searching and next attributes the pain to a pin hiding in a jacket pocket.

Moreover, across individuals, and across instances within an individual, what looks like the "same" action may differ in its antecedents. Different kinds of counterchange (sensitive domains) may be implicated and, with regard to a particular domain, any of a considerable range of conditions at Levels One and Two may have started the behavioral episode. Just a few of such possibilities are illustrated in Figure 13, where we observe someone putting on a sweater.

The relevant domain of sensitivity may be the sweater's warm-making characteristics or its imagined impact on the way others may evaluate the actor. As regards the actor's experiencing a sensation of cold, operative events at Level One may be a drop in air temperature or low blood sugar. As regards a drop in air temperature adjacent to an individual's skin, operative events at Level Two may be a broken thermostat/furnace/window, a fuel tank that has run dry, or a sudden change in the weather. In large part, the baffling quality of human action derives from the state of affairs illustrated in Figure 13, reading from right to left: The natural history of any one action is not immediately open to observation because of multiple possibilities regarding domains of Action and Sensitivity, Levels One, and Two antecedent events.

Representing the Producer Participating in an Episode

Finally, let me suggest the outline of a producer's use of this material. Minor differences in representing a behavioral episode in Figure 14 compared with Figure 7 result only from making space in Figure 14 to include aspects of the producer's task.

From the grand behavioral universe, a producer first selects a focal domain that corresponds to his or her

FIGURE 13 SOME POSSIBLE ANTECEDENTS FOR ACTION: "REACH FOR & DON SWEATER"

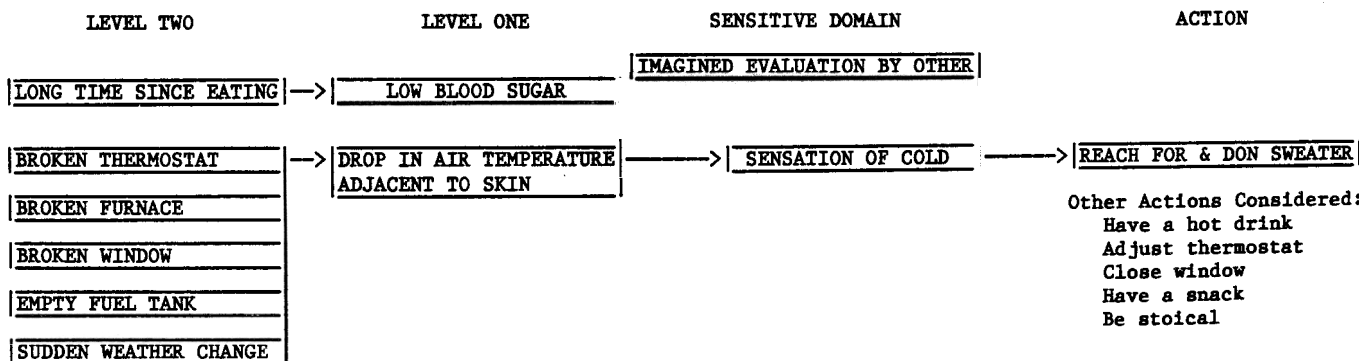

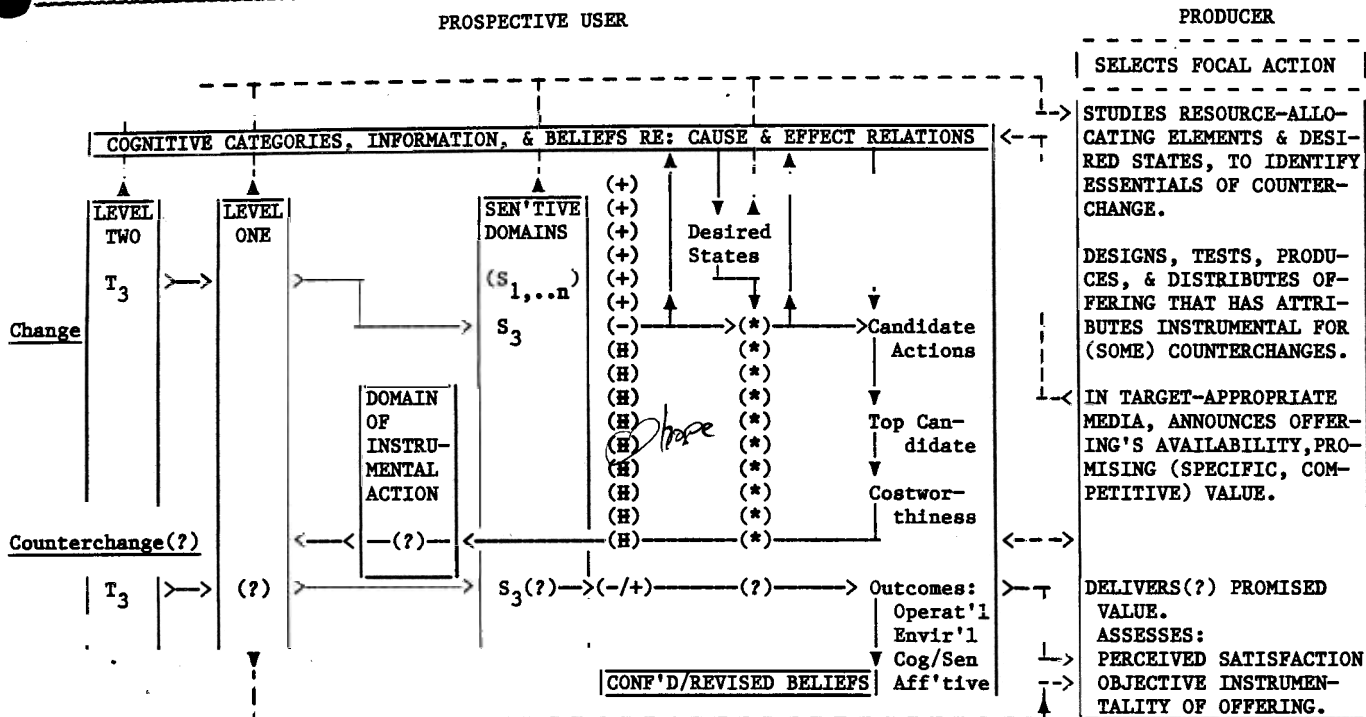

expertise and interest. Such a focal behavioral domain may comprise a few activities, which producers must study one at a time. The relevant behavioral universe for a producer is all instances of an activity (doing the laundry) in some region of space (US), and time (1987). Across individuals who perform the focal activity, and for instances of the activity within individuals, the operative psychological and nonpsychological elements likely vary. Because of this variation, with any one offering (brand), the producer plans to participate in only some of the attempted counterchanges in the focal behavioral domain.

Happily, for marketers studying behavioral science to help producers do the job society assigns, the ambiguity of action does not present the seemingly intractable problem traditionally lamented in psychology. We do not need to identify specific elements in individual real-world cases. Producers must be "accurate" for specific universes rather than for specific individuals. What producers need, above all, is a comprehensive framework that points to the kinds of elements likely to be found in a focal behavioral universe even if it is not possible to say with precision which individuals in the universe experience the conditions. For each focal behavioral domain—such as removing soil from clothes—a comprehensive framework, as in Figure 14, orients the producer to different aspects of the task of making what users would make for themselves. As producers address each aspect in turn, additional and more detailed conceptual aids are needed. In fields of their expertise, producers operate within a time frame stated in decades, and they may plan to identify and develop appropriate productive responses to the broad range of conditions that exist within any behavioral universe. The four domains of counterchange (Figures 10, 12, 13), orient producers to substantively different kinds of conditions that are relevant. Further work must refine how each term

is defined, and develop taxonomies within each domain.

References

Card, S. K., T. Moran, and A. Newell (1983), The Psychology of Human-Computer Interaction, Hillsdale, NJ: Erlbaum.

Fennell, G. (1987), Reculer Pour Mieux Sauter or, Why Consumer Psychologists Need a General Model of Action. In J. Saegert (Editor), Proceedings, Division of Consumer Psychology, 94th Annual Convention of the American Psychological Association.

(1980), The Situation. Motivation & Emotion, 4, (December), 299-322.

(1978), Consumers' Perceptions of the Product-Use Situation. Journal of Marketing, 42, 38-47.

Miller, G. A., E. Galanter, and Pribram, K. H. (1960), Plans and the Structure of Behavior, New York: Holt, Rinehart and Winston.

Norman, D. A. (1986), Cognitive Engineering. In D. A. Norman & S. Draper (Editors), User Centered System Design: New Perspectives in Human-Computer Interaction, Hillsdale, NJ: Erlbaum.

Pask, G. (1970), The Meaning of Cybernetics in the Behavioral Sciences. In J. Rose (Editor), Progress of Cybernetics Vol. 1, Main Papers: The Meaning of Cybernetics, Neuro- and Biocybernetics, London: Gordon, Breach.

and H. Von Foerster (1961), A Predictive Model for Self Organizing Systems. Cybernetica, IV, 258-300.

(For other references, please go to end of next page).

APPENDIX

FIGURE A-1 BEHAVIORAL CYBERNETIC MODEL (PASK, 1970)

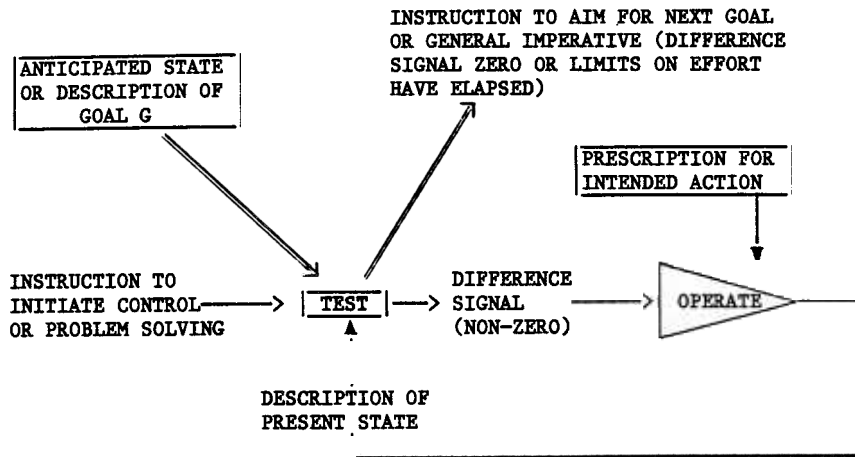

"Figure 1 The basic goal directed system: a TOTE unit (modified)" (Pask 1970, p. 19).

FIGURE A-2 CONTROL THEORY MODEL (POWERS, 1973)

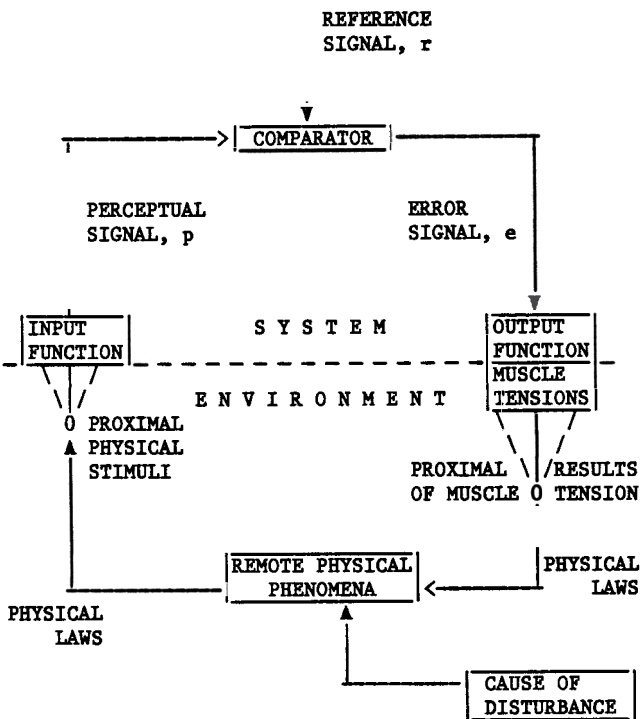

"Figure 5.2 General model of a feedback control system and its local environment" (Powers, 1973, p. 61).

FIGURE A-3 USER-CENTERED MODEL (NORMAN, 1986)

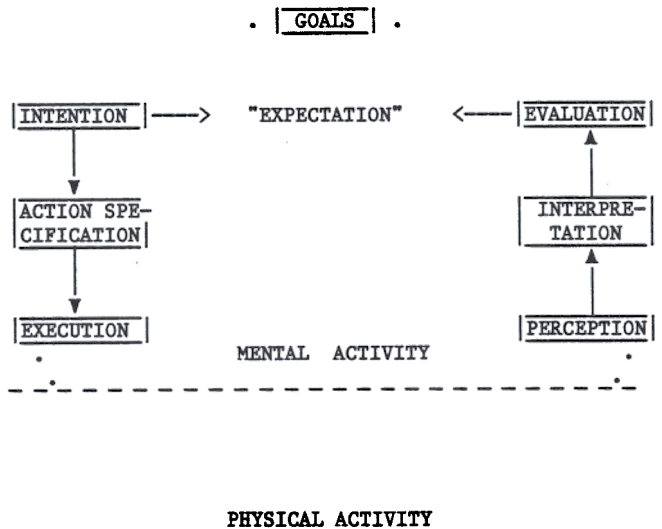

"Figure 3.3 Seven stages of user activities involved in the performance of a task" (Norman, 1986 p. 42).

References (cont'd)

Powers, W. T. (1973), Behavior: The Control of Perception, Chicago: Aldine.

Sluckin, W (1954), Minds and Machines, London: Penguin

Wiener, N. (1948), Cybernetics, New York: Wiley.

Wisdom, J. O. (1951), The Hypothesis of Cybernetics. British Journal for the Philosophy of Science.