



PUMP SPECIFICATION

AE Series

Description: Heavy duty dual seal effluent submersible pump.

Pump Electrical Specification

Model#	Hz:	Voltage:	HP:	Discharge:	Speed	Shutoff	Max Flow & Head	Wt. (lbs)	LRA	FLA	Cord	Cord length
AE100/1	60	120v	1HP	2"	2P/3500	41'	See Max Operating conditions	45	25	5	UL(E231992-K) SJO	20'
AE100/2	60	220v	1HP	2"		41'		45	50	10		20'
AE100/3	60	230v	1HP	2"		41'		47	50	3.5		20'
AE100/4	60	460v	1HP	2"		41'		47	8.5	1.7		20'
AE200/2	60	230v	2HP	3"		55'		75	50	10		20'
AE200/3	60	230	3HP	3"		55'		75	32.5	6.5		20'
AE/200/4	60	460	3HP	3"		55'		75		3.3		20'
AE300/3	60	230	3HP	3"		75'		79	50	10		50'
AE300/4	60	460	3HP	3"		75'		79	22.5	4.5		50'
AE500/3	60	230v	5HP	5"		75'		144	45	6		50'
AE500/4	60	480	5HP	5"	75"	144	45	9	50"			



Pump Curve

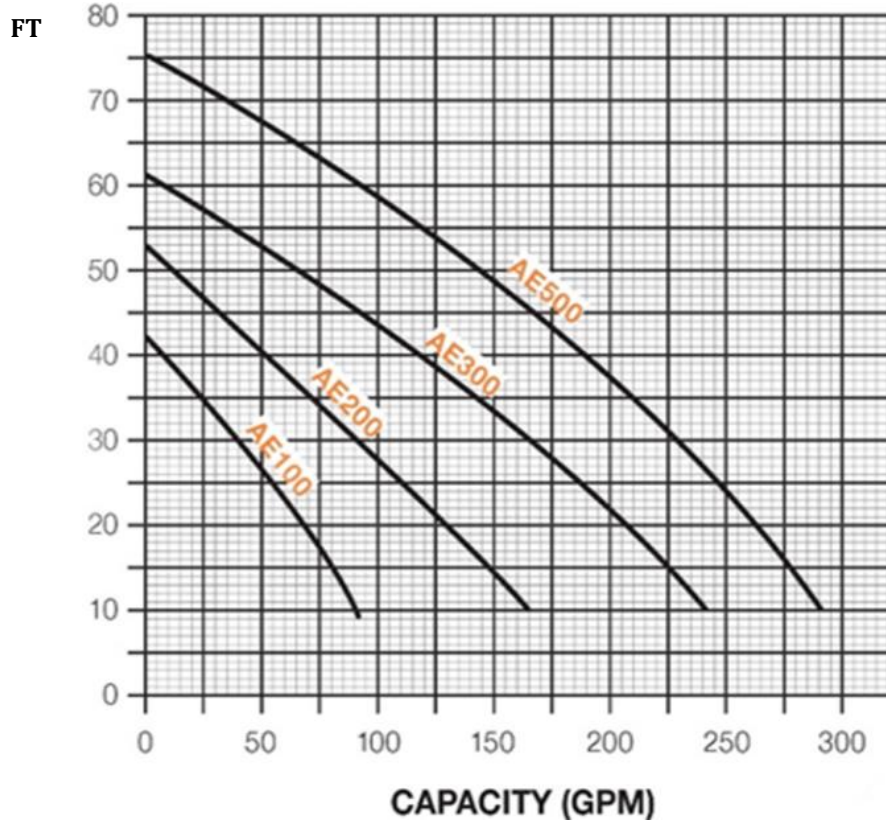

Max Operating Conditions:

Model	AE100(/3)	AE200(/3)	AE300	AE500(/3)
TDH	10	10	8	9
GPM	93	159	245	285



Pump Dimensions

Model	DN	A	B	C	D	E	F	G	I	J	K	L	M	N	O	W1	W2	H1	H2
AE100	2"	16.93	13.98	1.57	6.69	7.28	2.76	4.13	1.97	8.66	1"	3.54	10.83	10.04	4.72	17.13	7.09	19.29	1.77
AE200	3"	25.20	18.11	3.74	8.66	7.28	2.76	5.12	1.97	11.81	1.25"	5.71	12.01	10.83	5.12	20.87	7.09	23.03	.98
AE300	3"	23.03	15.75	3.74	8.66	7.28	2.76	5.12	1.97	8.66	1.25"	5.71	12.01	10.83	5.12	21.85	10.83	24.02	4.72
AE500	3"	14.17	17.52	3.74	9.84	7.28	2.76	5.12	1.97	11.02	1.25"	5.71	12.01	10.83	5.12	22.83	10.83	25.39	4.53

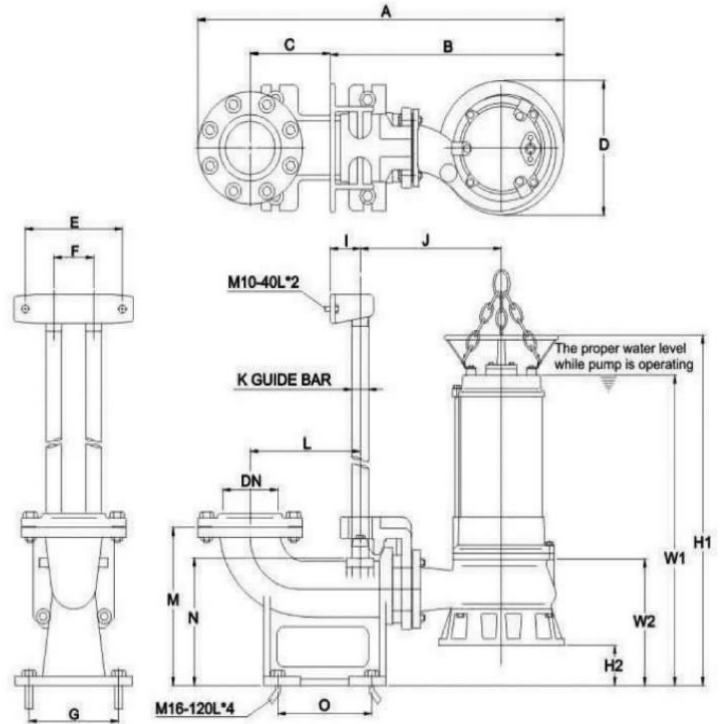
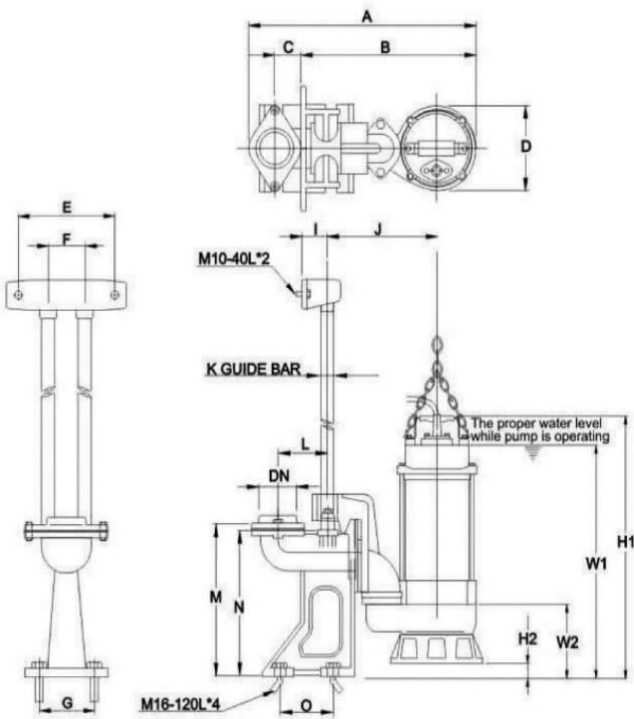



Specifications

- **Specified Operation:** Model _____ to perform at ___gpm at ___ tdh, ___V/_ph.
- **Overview:** AE series pumps are designed to be used in effluent applications where solids concentration is low and no larger than 2"-3" respectively.
- **Operating:** AE pumps should always be operated on/in accordance with their hydraulic performance curves and should not be operated under overload conditions (ie: too far to the right side of the respective performance curve).
- **Construction:** Each pump volute, impeller, backing plate, and motor cap is constructed of FC200 (Class 30) cast iron and 304 stainless steel.
- **Motor:** Offered in single phase and three phase each motor is air filled with a dual seal oil filled chamber to protect the motor's electrical components from water intrusion at the liquid end of the pump. Motor is housed in an FC200 cast iron casing.
- **Shaft:** Each shaft is made of 420 stainless steel and adequately sized with a **1.3 or greater** safety factor for use under maximum pumping volumes.
- **Bearings:** Each motor shaft will rotate on one heavy-duty sealed bearing at the top and bottom of the motor shaft.
- **Seals:** Each pump motor will be protected by a dual seal design with Silicon Carbide /Silicon Carbide seal on the pump side and carbon/ceramic on the motor side.
- **Oil Chamber :** Each pump will come with an oil filled seal chamber with ISO VG. Number 32 hydraulic oil.
- **Power Cable:** Minimum 20' (6M) UL listed (E231992-K) SJO cable will be supplied. Longer cables will be adequately sized based upon UL standards.
- **Volute:** Constructed of FC200 (Class 30) cast iron
- **Impeller:** Non-clog vortex type impeller constructed of FC200 (Class 30) cast iron
- **Stand:** Ring-style stand constructed of FC200 (Class 30) cast iron will support the entire pump.
- **Transport:** One each 304 stainless steel handle with a contoured rubber top coating will provide an easily transportable grip.
- **Paint:** Cast iron components will be painted with an epoxy paint that meets ASTM standards.
- **Repair:** Standard repair parts will be stocked domestically for fast shipping.
- **Testing:** Each pump will be tested before being packaged for shipment.
- **Warranty:** Each pump has a 12-month warranty with additional months upon request.
-