



Pump Specification

Pump Series: AF SERIES

Description: The AF series is a high-performance sump pump with an incredibly durable vulcanized rubber base, roller bearings, dual seals and an epoxy coated cast iron and aluminum body for superior corrosion resistance.

This pump is designed for applications such as gray water evacuation, commercial dewatering, elevator sumps, truck dock sumps, irrigation, pool drainage, and many more applications. The compact design allows this pump to offer robust features without taking up much space in the work truck or shelf.

- Vertical float switch available by request (VERT20-P1).

Pump Electrical Specifications													
Model#	Hz:	Voltage:	HP:	Discharge:	Speed	Shutoff	Max Flow & Head	Wt. (lbs)	LRA	FLA	Cord		Cord length
AF5	60	110V	.5	2"	3450	42'	See Max Operating conditions	28		7.2	UL(E231992-K) SJO		20'
AF75	60	110V	.75	2"		60'		33		12.3			20'



Pump Curve & Max Operating Condition

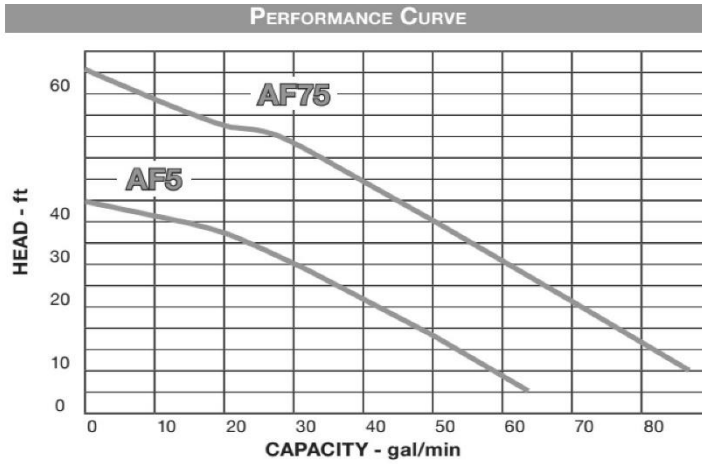

Model #	AF5	AF75
GPM	60	84
TDH	42'	60'

Pump Dimensions

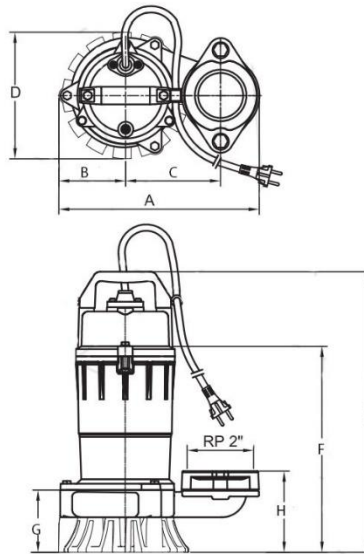

Inches	A	B	C	D	E	F	G	H
AF5	10"	3.74"	4.72"	7.08"	14.37"	10.39"	3.5"	4.33"
AF75	11.25"	3.74"	5.31"	7.08"	14.95"	10.78"	3.54"	4.56"



Aqua Pro Pump Systems
a Tomiko Inc. Company

Specifications

- **Specified Operation:** Model AF to perform at ___ GPM at ___ TDH, ___V/ _ph.
- **Overview:** AF series pumps are designed to be used in sump applications where solids concentration is low and no larger than 1/2" respectively.
- **Operating:** AF pumps should always be operated on/in accordance with their hydraulic performance curves and should not be operated under overload conditions (ie: too far to the right side of the respective performance curve).
- **Construction:** Each pump volute, impeller, backing plate, and motor cap is constructed of FC200 (Class 30) cast iron and 304 stainless steel.
- **Motor:** Offered in single phase air filled with a dual seal oil filled chamber to protect the motor's electrical components from water intrusion at the liquid end of the pump. Motor is housed in an FC200 cast iron casing.
- **Shaft:** Each shaft is made of 420 stainless steel and adequately sized with a **1.3 or greater** safety factor for use under maximum pumping volumes.
- **Bearings:** Each motor shaft will rotate on one heavy-duty sealed bearing at the top and bottom of the motor shaft.
- **Seals:** Each pump motor will be protected by a dual seal design with Silicon Carbide /Silicon Carbide seal on the pump side and carbon/ceramic on the motor side.
- **Oil Chamber:** Each pump will come with an oil filled seal chamber with ISO VG. Number 32 hydraulic oil.
- **Power Cable:** Minimum 20' (6M) UL listed (E231992-K) SJO cable will be supplied. Longer cables will be adequately sized based upon UL standards.
- **Volute:** Constructed of FC200 (Class 30) cast iron.
- **Impeller:** Non-clog vortex type impeller constructed of Semi-vortex urethane.
- **Stand:** Heavy duty non-metallic vulcanized rubber stand to support the entire pump.
- **Transport:** One heavy duty plastic handle with contour to provide easy transport.
- **Paint:** Cast iron components will be painted with an epoxy paint that meets ASTM standards.
- **Repair:** Standard repair parts will be stocked domestically for fast shipping.
- **Testing:** Each pump will be tested before being packaged for shipment.
- **Warranty:** Each pump has a 12-month warranty with additional time upon request.