

PATTERN

2

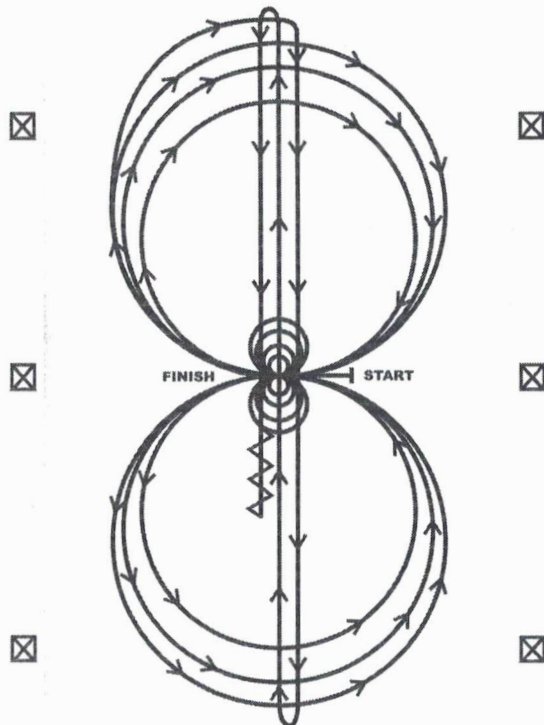

©NRHA

PATTERN

2

Horses may walk or jog to the center of arena. Horses must walk or stop prior to starting pattern. Beginning at the center of the arena facing the left wall or fence.

1. Beginning on the right lead, complete three circles to the right: the first circle small and slow; the next two circles large and fast. Change leads at the center of the arena.
2. Complete three circles to the left: the first circle small and slow; the next two circles large and fast. Change leads at the center of the arena.
3. Continue around previous circle to the right. At the top of the circle, run down the middle to the far end of the arena past the end marker and do a right rollback—no hesitation.
4. Run up the middle to the opposite end of the arena past the end marker and do a left rollback—no hesitation.
5. Run past the center marker and do a sliding stop. Back up to the center of the arena or at least ten feet (three meters). Hesitate.
6. Complete four spins to the right. Hesitate.
7. Complete four spins to the left. Hesitate to demonstrate the completion of the pattern.

PATTERN

13

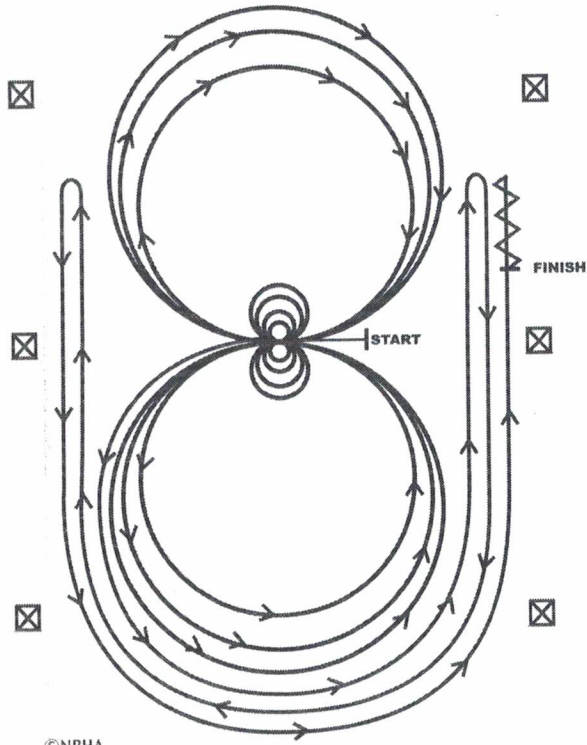

©NRHA

PATTERN

13

Horses must walk or stop prior to starting pattern. Beginning at the center of the arena facing the left wall or fence.

1. Beginning on the left lead, complete two circles to the left: the first circle large and fast; the second circle small and slow. Stop at the center of the arena. Hesitate.
2. Complete four spins to the left. Hesitate.
3. Beginning on the right lead, complete two circles to the right: the first being large and fast; the second circle small and slow. Stop at the center of the arena. Hesitate.
4. Complete four spins to the right. Hesitate.
5. Beginning on the left lead, run a large fast circle to the left, change leads at the center of the arena, run a large fast circle to the right, and change leads at the center of the arena.
6. Continue around previous circle to the left but do not close this circle. Run up the right side of the arena past the center marker and do a right rollback at least 20 feet (6meters) from the wall or fence-no hesitation.
7. Continue around previous circle but do not close this circle. Run up the left side of the arena past the center marker and do a left rollback at least 20 feet (6 meters) from the wall or fence-no hesitation.
8. Continue back around previous circle but do not close this circle. Run up the right side of the arena past the center marker and do a sliding stop at least 20 feet (6 meters) from the wall or fence. Back up at least 10 feet (3 meters). Hesitate to demonstrate completion of pattern.

PATTERN

3

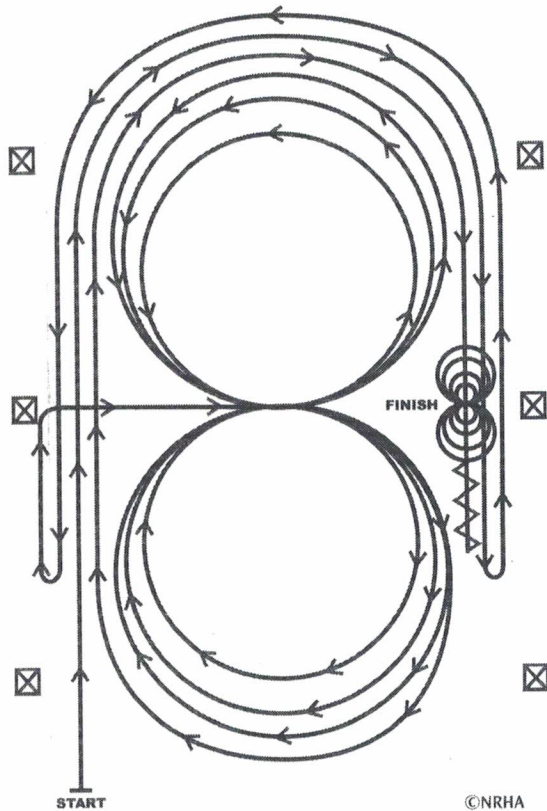

PATTERN

3

1. Beginning, lope straight up the left side of the arena, circle the top end of the arena, and staying at least twenty feet (six meters) from the walls or fence, run straight down the opposite or right side of the arena past the center marker and do a left rollback—no hesitation.

2. Continue straight up the right side of the arena circle back around the top of the arena, and staying at least twenty feet (six meters) from the walls or fence, run straight down the left side of the arena past the center marker and do a right rollback—no hesitation.

3. Continue up the left side of the arena to the center marker. At the center marker, the horse should be on the right lead. Guide the horse to the center of the arena on the right lead and complete three circles to the right: the first two circles large and fast; the third circle small and slow. Change leads at the center of the arena.

4. Complete three circles to the left: the first two circles large and fast; the third circle small and slow. Change leads in the center of the arena.

5. Begin a large circle to the right but do not close this circle. Continue up the left side of the arena, circle the top of the arena, and staying at least twenty feet (six meters) from the walls or fence, run straight down the opposite or right side of the arena past the center marker and do a sliding stop. Back up at least ten feet (three meters). Hesitate.

6. Complete four spins to the right. Hesitate.

7. Complete four spins to the left. Hesitate to demonstrate completion of the pattern.

Classes 210-211

PATTERN

1

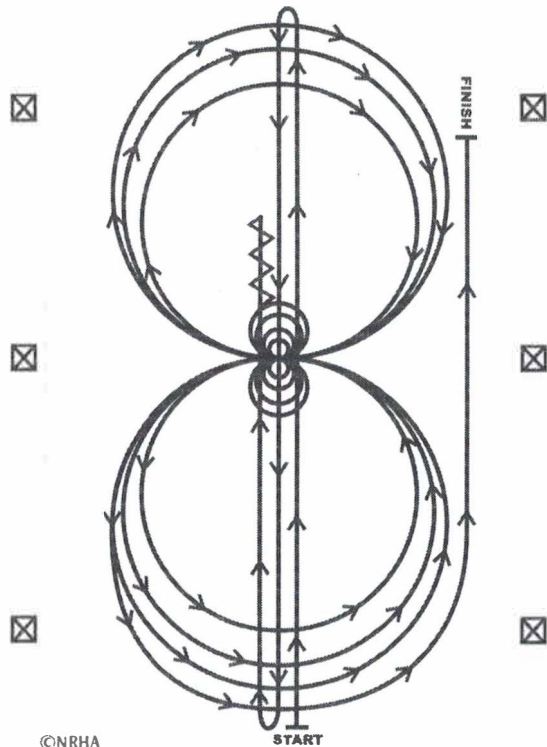

©NRHA

START

FINISH

PATTERN

1

1. Run at speed to the far end of the arena past the end marker and do a left rollback—no hesitation.
2. Run to the opposite end of the arena past the end marker and do a right rollback—no hesitation.
3. Run past the center marker and do a sliding stop. Back up to center of the arena or at least ten feet (three meters). Hesitate.
4. Complete four spins to the right. Hesitate.
5. Complete four and one-quarter spins to the left so that horse is facing left wall or fence. Hesitate.
6. Beginning on the left lead, complete three circles to the left: the first circle large and fast; the second circle small and slow; the third circle large and fast. Change leads at the center of the arena.
7. Complete three circles to the right: the first circle large and fast; the second circle small and slow; the third circle large and fast. Change leads at the center of the arena.
8. Begin a large circle to the left but do not close this circle. Run straight up the right side of the arena past the center marker and do a sliding stop at least twenty feet (six meters) from wall or fence. Hesitate to demonstrate the completion of the pattern.

RANCH RIDING - PATTERN I

Classes 220-222

LEGEND

.....	Walk
....	Extended Walk
- - -	Trot
- - - -	Extended Trot
— — —	Lope
— — — —	Extended Lope
////	Back
//	Lead Change

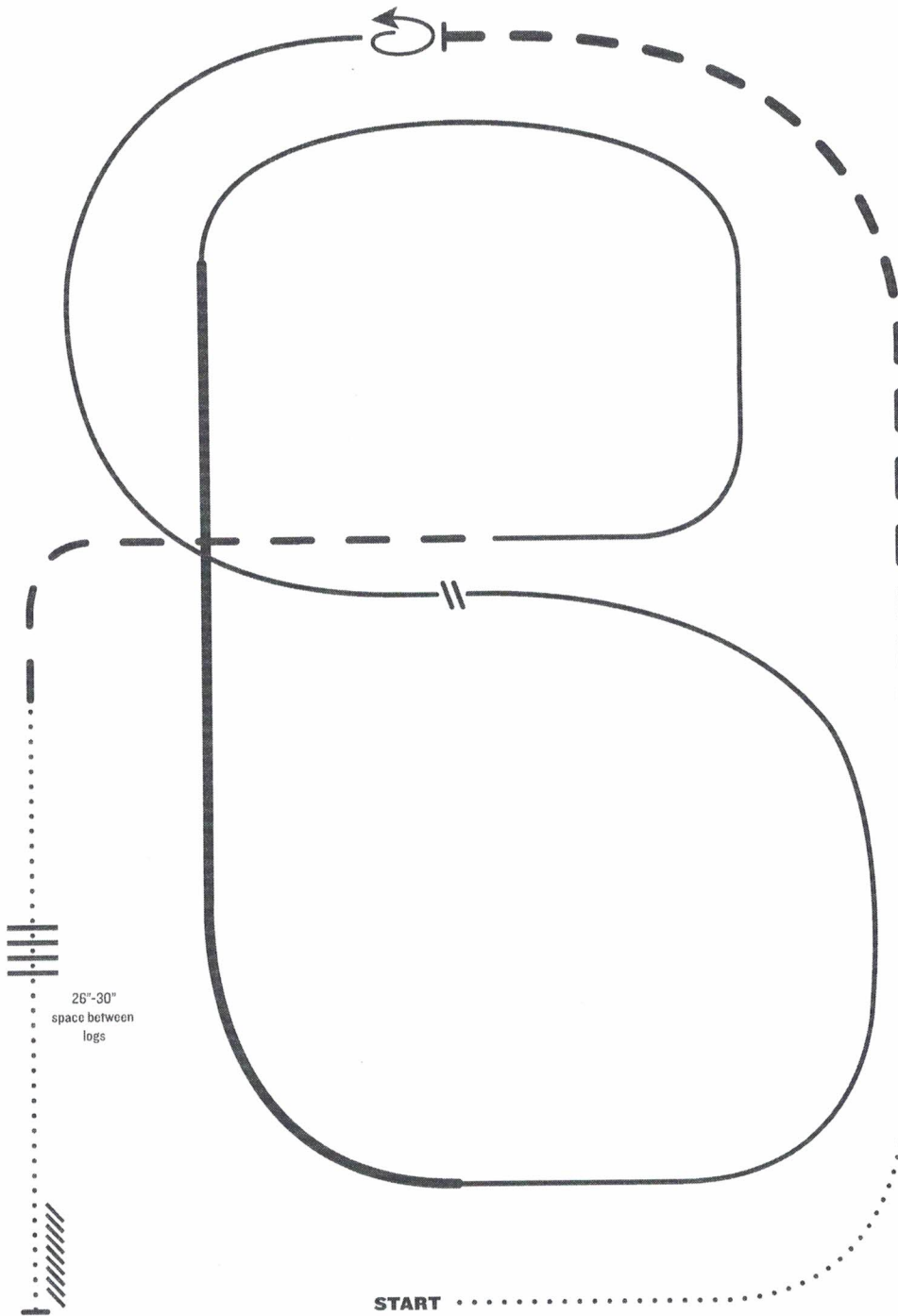

1. Walk
2. Trot
3. Extend the trot, at the top of the arena, stop
4. 360° turn left
5. Left lead 1/2 circle, lope to the center
6. Change leads (simple or flying)
7. Right lead 1/2 circle
8. Extended lope up the long side of the arena (right lead)
9. Collect back to a lope around the top of the arena and back to center
10. Break down to an extended trot
11. Walk over logs
12. Stop and back

Note: The drawn description of this pattern is only intended for the general depiction of the pattern. Exhibitors should utilize the arena space to best exhibit their horses.

RANCH RIDING - PATTERN 12

Classes 223-227

LEGEND

.....	Walk
....	Extended Walk
- - -	Trot
- - - -	Extended Trot
— — —	Lope
— — — —	Extended Lope
////	Back
\\	Lead Change

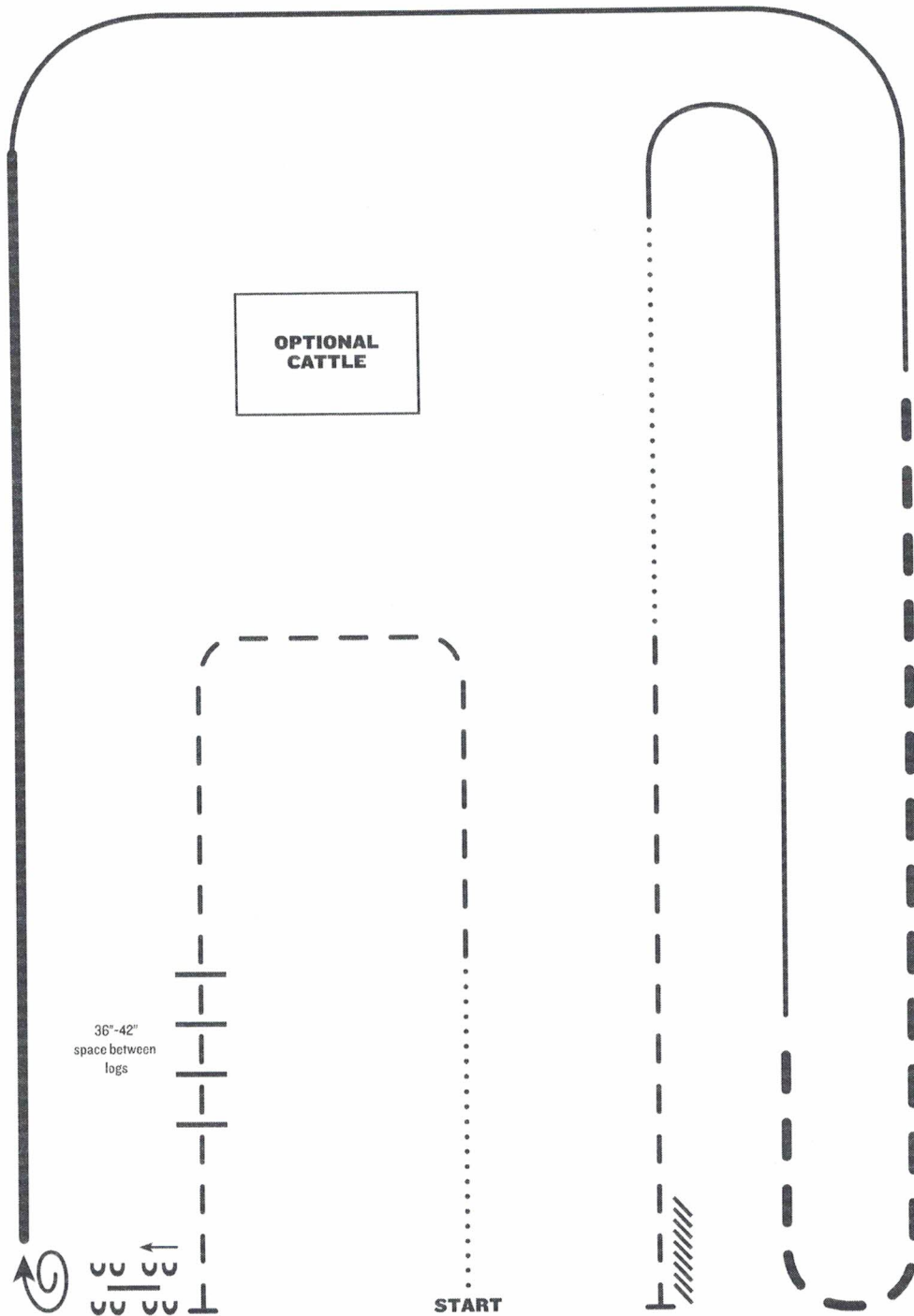

1. Walk
2. Trot
3. Trot over logs, stop
4. Side pass right over log
5. 1/2 turn right
6. Extended lope right lead
7. Lope right lead
8. Extended trot
9. Lope left lead
10. Walk
11. Trot
12. Stop and back

Note: The drawn description of this pattern is only intended for the general depiction of the pattern. Exhibitors should utilize the arena space to best exhibit their horses.

Classes 228-230

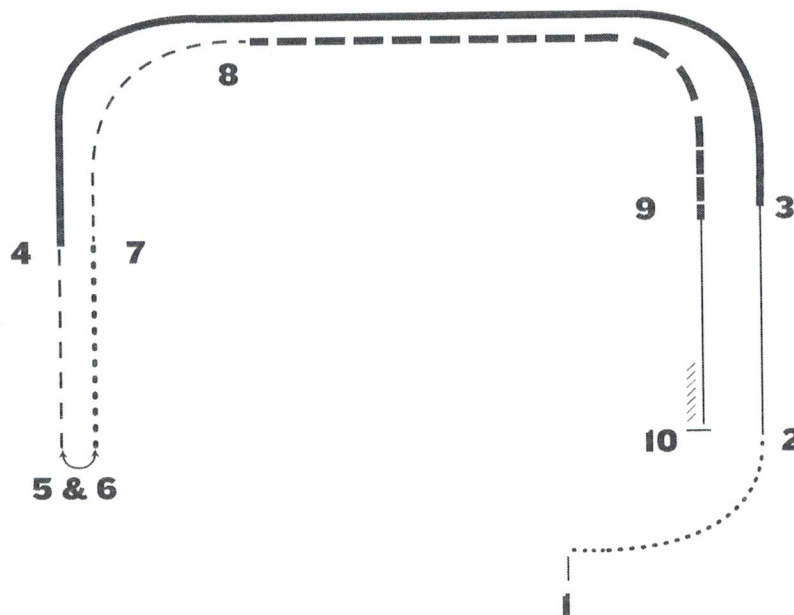

When establishing the course, the following distances are suggested. Patterns may begin in either direction and markers are optional.

1. Walk from 1 to 2 - 30 feet
2. Lope from 2 to 3 - 150 feet
3. Extended Lope from 3 to 4 - 200 feet
4. Trot from 4 to 5 - 120 feet
5. Stop at 5; reverse (either direction)
6. Extended Walk from 6 to 7 - 75 feet
7. Trot from 7 to 8 - 90 feet
8. Extended Trot from 8 to 9 - 240 feet
9. Lope from 9 to 10 - 150 feet
10. Stop and Back at 10 - approximately one horse length

- Walk (dotted line)
- Extended Walk ●●●●●●●●●● (dotted line with dots)
- Trot ●●●●●●●●●● (dotted line with larger dots)
- Extended Trot — — — — — (dashed line)
- Lope ————— (solid line)
- Extended Lope ————— (thick solid line)
- Back \\\ \\\ \\\ \\\ \\\ (hatched line)

Classes 239-247

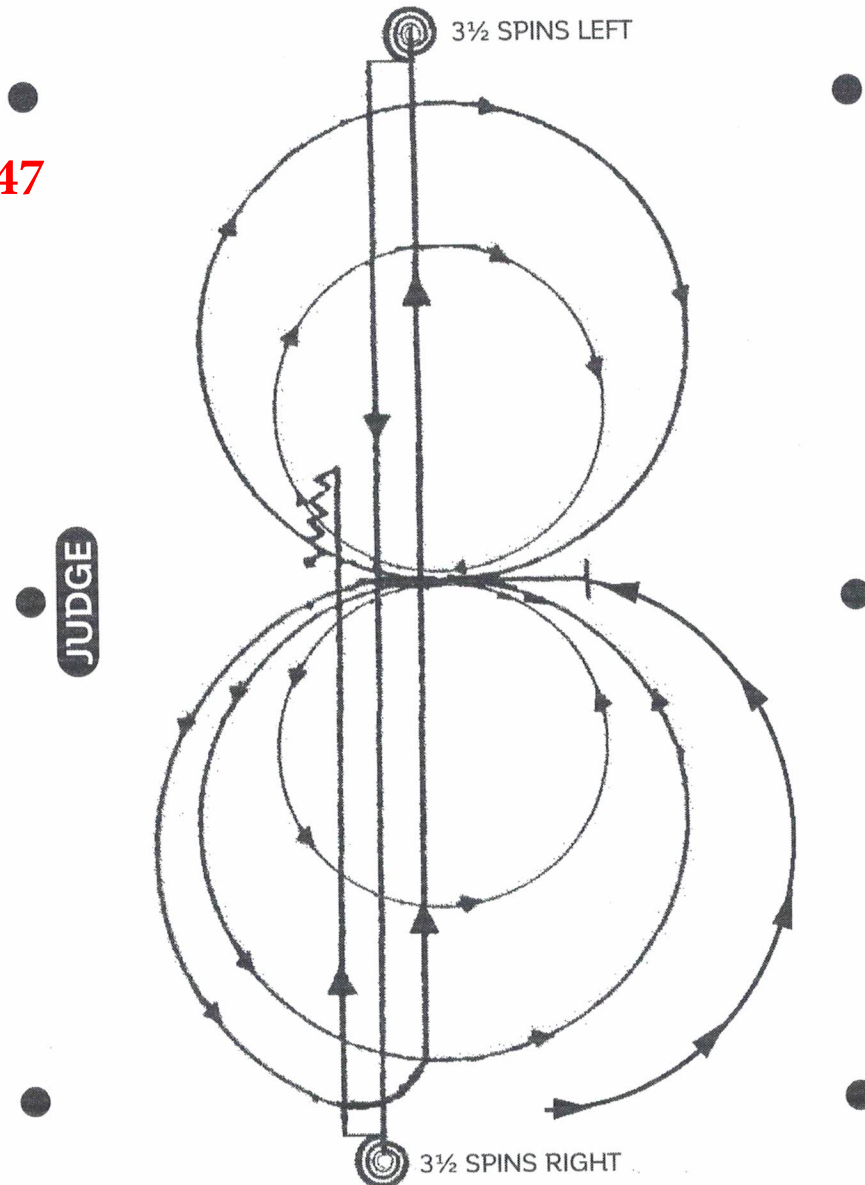

Begin on left lead. At the center, without stopping or breaking gait, begin pattern facing toward the judge. Refer to rule 20.6.

1. Beginning on the left lead complete 2 circles to the left, the first circle large and fast, and the second circle small and slow. Change leads at the center of the arena.
2. Complete 2 circles to the right, the first large and fast, the second small and slow. Change leads at the center of the arena.
3. Continue around end of arena without breaking gait or changing leads, run down center of the arena past the end marked, execute a square sliding stop.
4. Complete 3 1/2 spins to the left.
5. Run down center of arena past end marker, execute a square sliding stop.
6. Complete 3 1/2 spins to the right.
7. Run down center of arena past center marker, execute a square sliding stop. Back at least 10 feet. Hesitate to complete pattern.