

RANCH RIDING WALK/TROT PATTERN

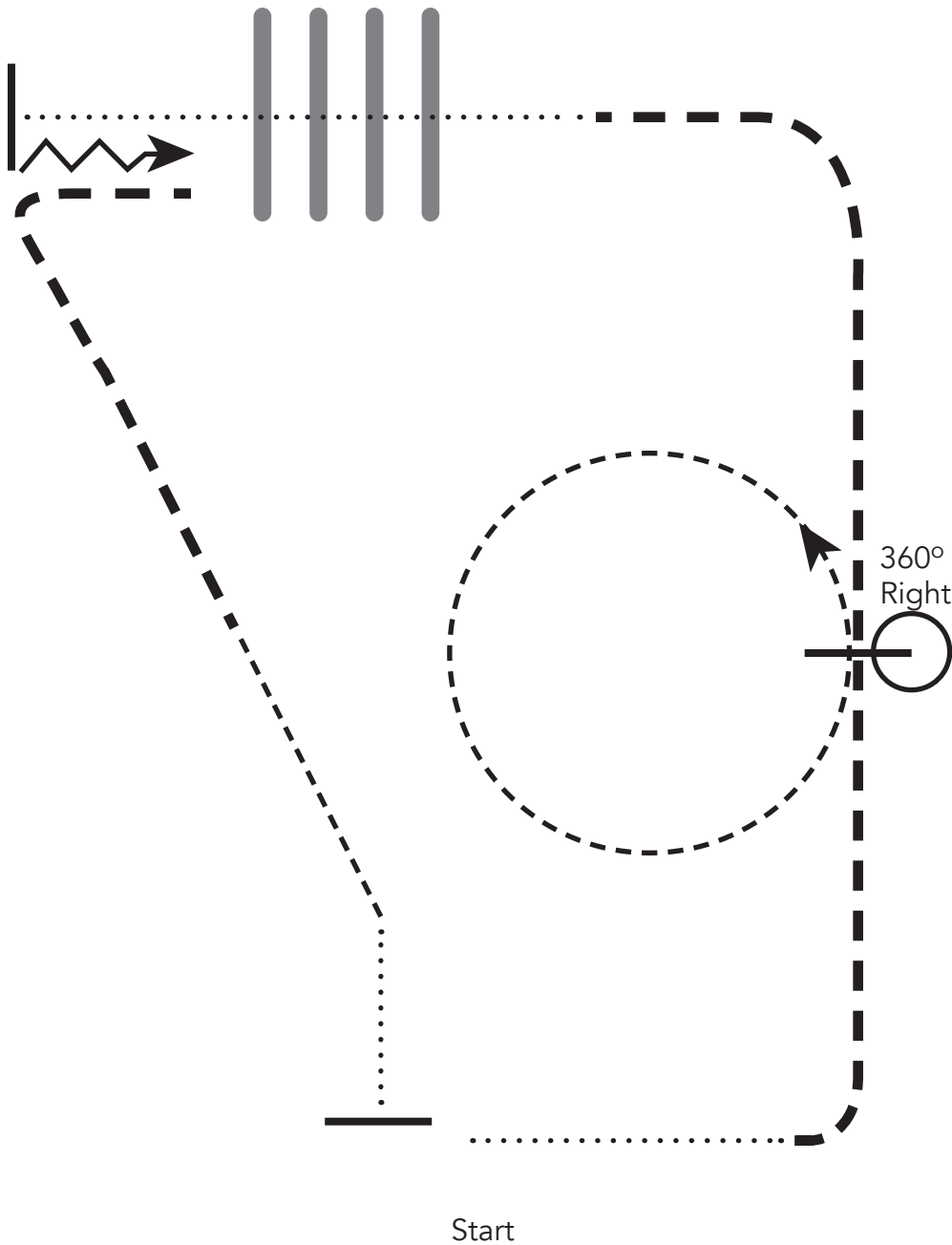





PATTERN 2

To be used for Walk/Trot 10 & Under and 11 & Over

The drawn description of this pattern is only intended for the general depiction of the pattern.
 Exhibitors should utilize the arena to best exhibit their horses.



1. Walk.
2. Extended trot.
3. Stop, and turn 360-degrees right.
4. Trot circle to left.
5. Extended trot.
6. Walk over poles.
7. Stop and back.
8. Extended trot.
9. Trot.
10. Walk.
11. Exit the arena at the walk.

	Stop / Halt
	Extended Trot
	Trot
	Walk
	Back
	Log

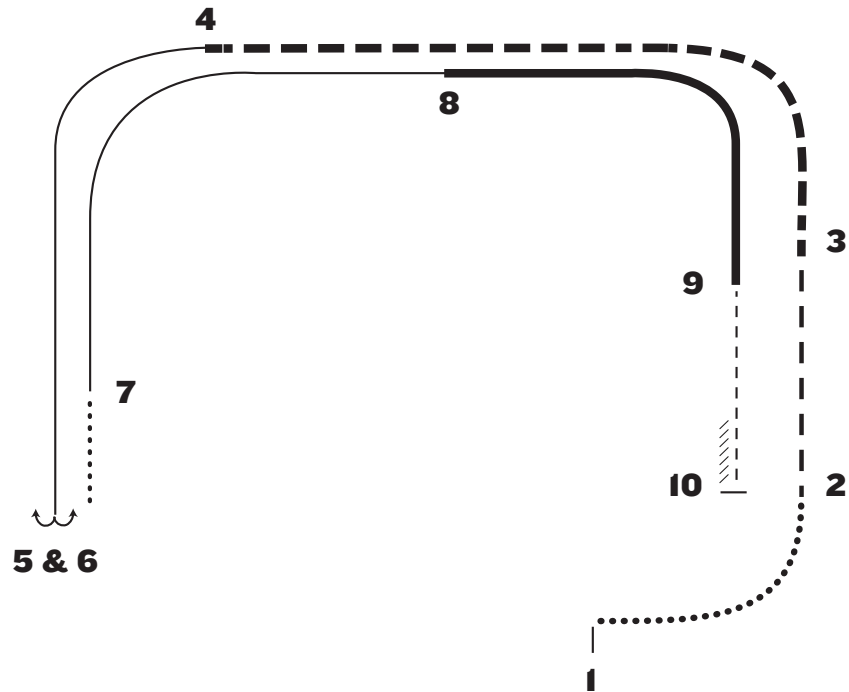
OPTIONAL VRH AND RHC RANCH RIDING PATTERN I

When establishing the course, the following distances are suggested. Patterns may begin in either direction and markers are optional.

- 1.** Extended Walk from 1 to 2 - 75 feet
- 2.** Trot from 2 to 3 - 120 feet
- 3.** Extended Trot from 3 to 4 - 240 feet
- 4.** Lope from 4 to 5 - 150 feet
- 5.** Stop at 5; reverse (either direction)
- 6.** Walk from 6 to 7 - 30 feet
- 7.** Lope from 7 to 8 - 150 feet
- 8.** Extended Lope from 8 to 9 - 200 feet
- 9.** Trot from 9 to 10 - 90 feet
- 10.** Stop and Back at 10 - approximately one horse length

Walk
Extended Walk	●●●●●●●●
Trot	●●●●●●●●
Extended Trot	— — — — —
Lope	—————
Extended Lope	—————
Back	\\\\\\\\\\\\

RANCH RIDING - PATTERN 4**LEGEND**

.....	Walk
....	Extended Walk
- - -	Trot
- - -	Extended Trot
— — —	Lope
— — —	Extended Lope
////	Back
//	Lead Change

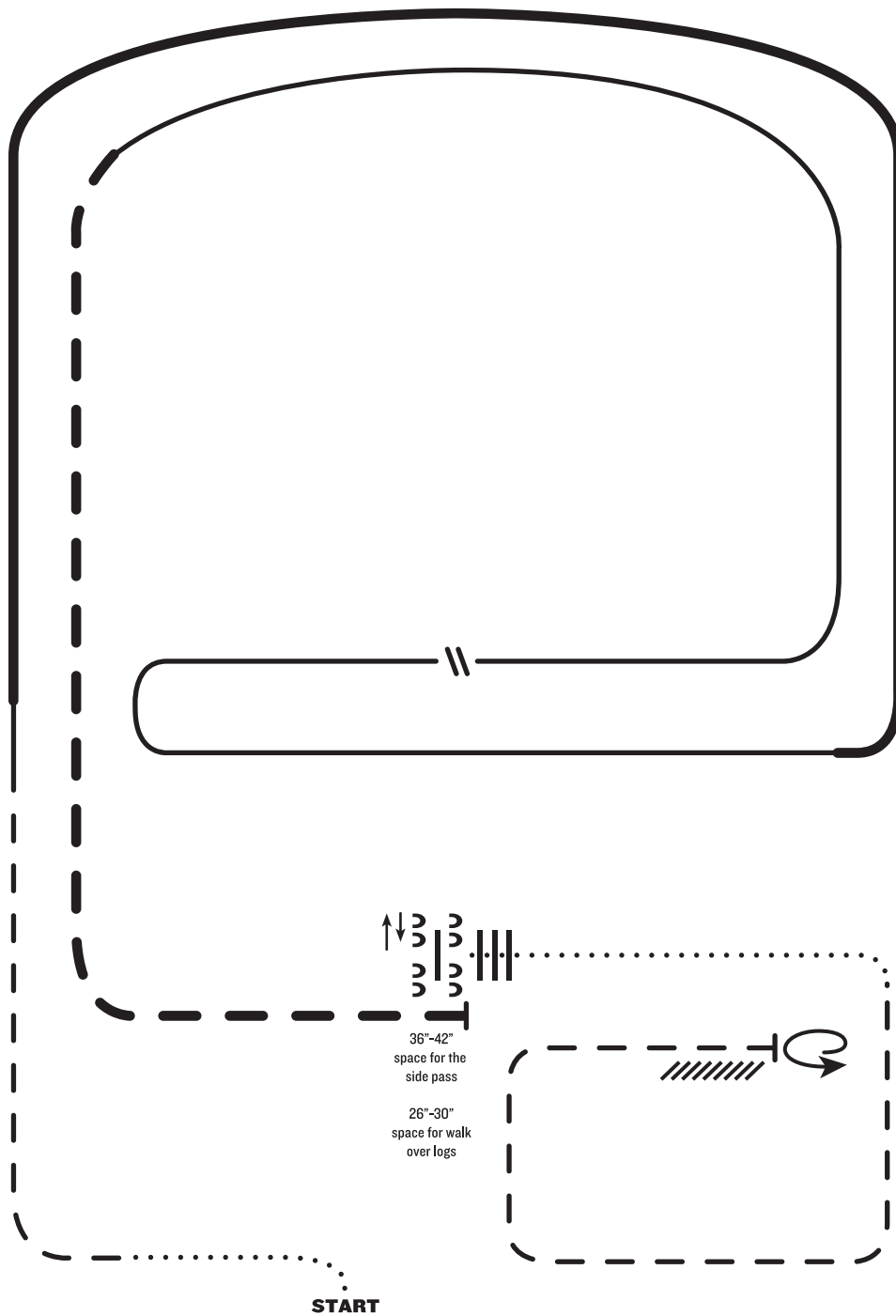

1. Walk
2. Trot
3. Extended lope right lead
4. Lope right lead
5. Change leads (simple or flying)
6. Lope left lead
7. Extended trot
8. Stop, side pass left, side pass right, 1/2 way
9. Walk over logs
10. Walk
11. Trot square
12. Stop, 360° turn left, and back

Note: The drawn description of this pattern is only intended for the general depiction of the pattern. Exhibitors should utilize the arena space to best exhibit their horses.

RANCH RIDING - PATTERN 7

LEGEND

.....	Walk
....	Extended Walk
- - -	Trot
- - -	Extended Trot
— — —	Lope
— — —	Extended Lope
////	Back
\\	Lead Change

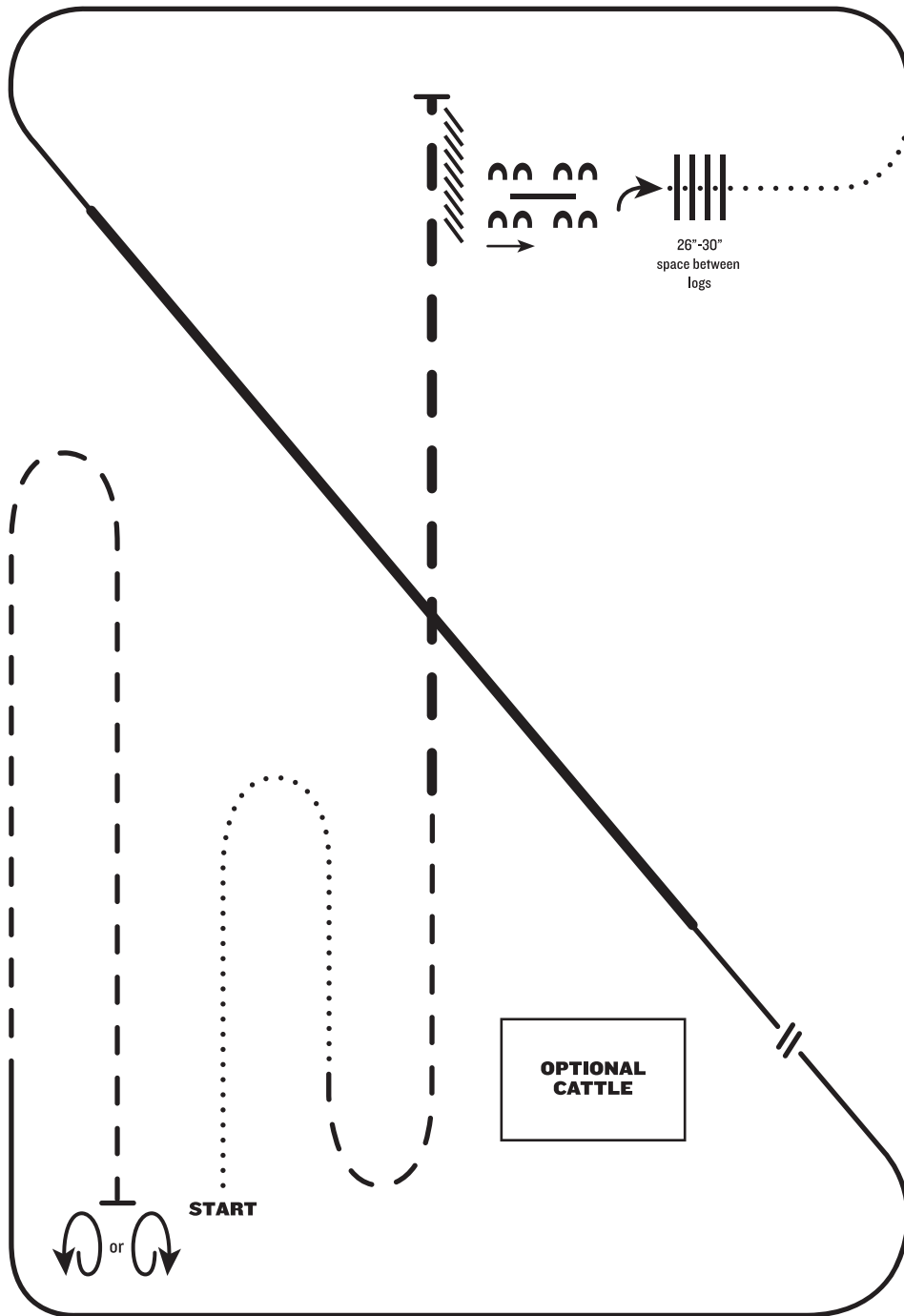

1. Walk
2. Trot
3. Extended trot
4. Stop and back
5. Side pass right over log
6. 1/4 turn right, walk over logs
7. Walk
8. Lope left lead
9. Extended lope left lead
10. Collect lope, change leads (simple or flying)
11. Lope right lead
12. Trot
13. Stop, one 360° turn either direction

Note: The drawn description of this pattern is only intended for the general depiction of the pattern. Exhibitors should utilize the arena space to best exhibit their horses.

PATTERN 1

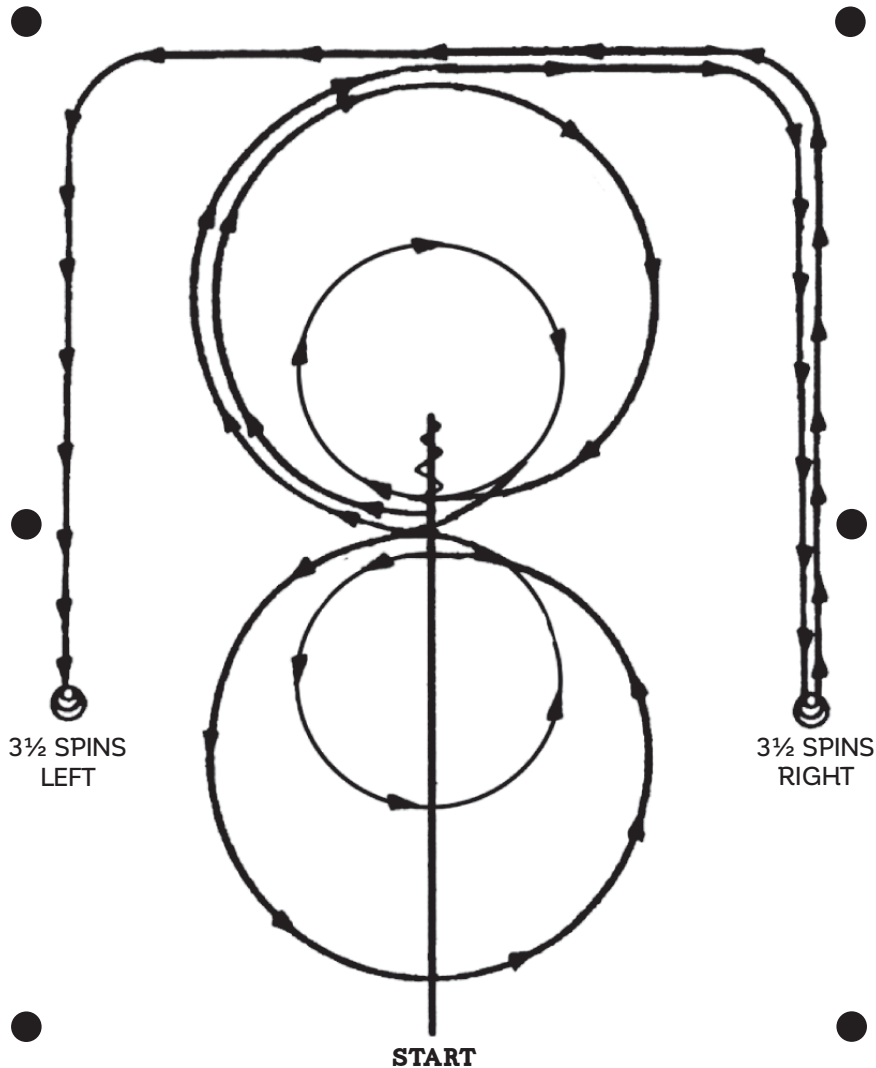

1. Start at end of arena. Run down middle past center marker to a sliding stop. Back at least 10 feet to center. $\frac{1}{4}$ turn left.
2. Beginning on the right lead, complete 2 circles to the right. The first one large and fast, the second small and slow. Change leads at the center of arena.
3. Complete 2 circles to the left. The first circle large and fast, the second circle small and slow. Change leads at the center of arena.
4. Continue around end of arena without breaking gait or changing leads, run down the side (approximately 20 feet from fence) past center marker and come to a sliding stop.
5. Complete $3\frac{1}{2}$ spins to the right.
6. Continue back down side and end of arena to other side (approximately 20 feet from fence) go past center marker and come to a sliding stop.
7. Complete $3\frac{1}{2}$ spins to the left. Hesitate to complete pattern.

PATTERN 6

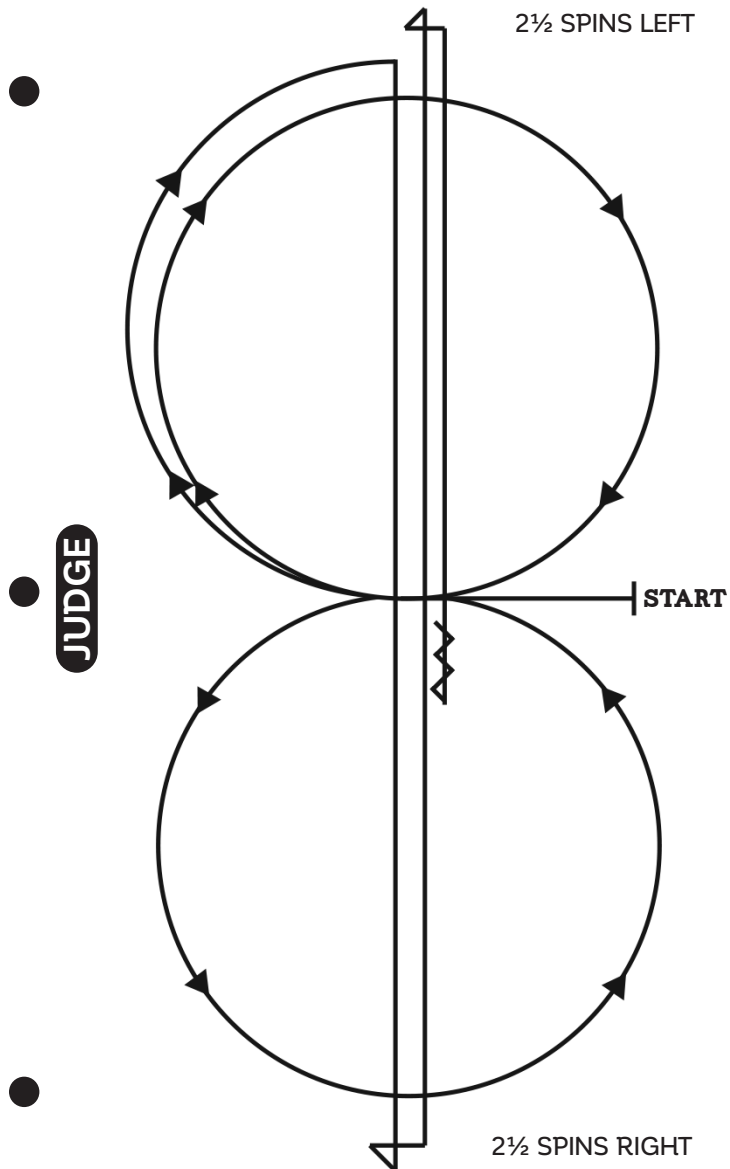

- Trot to center of arena, stop. Start pattern facing towards judge
- 1. Beginning on the right lead lope one circle to the right. Change leads to the left.
 2. Complete one circle to the left. Change leads to the right and go to the top of the arena.
 3. Run down center of arena past the end marker and come to a sliding stop.
 4. Complete 2½ spins to the right.
 5. Run to the other end of the arena, past the end marker and come to a sliding stop.
 6. Complete 2½ spins to the left.
 7. Run past the center marker, stop and back at least 10 feet.

*This pattern may be used as a lope in pattern, please refer to rule 20.6.

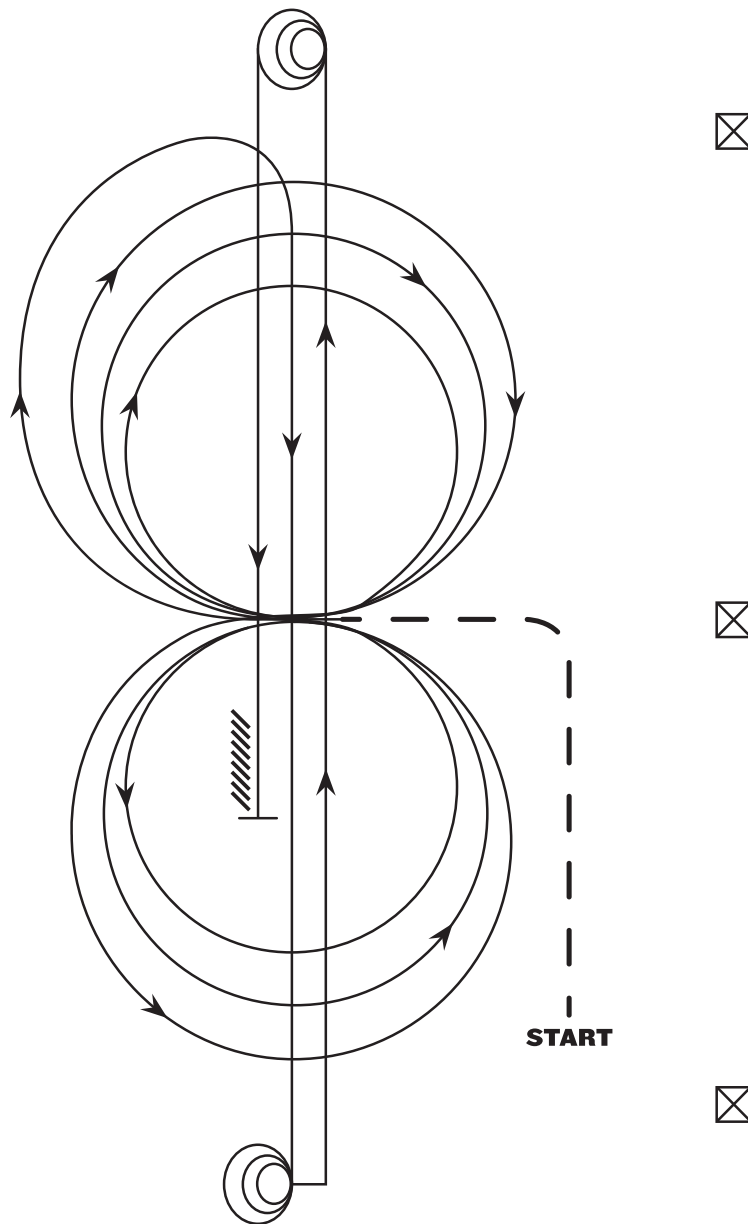
VRH AND RHC RANCH REINING PATTERN 3

Mandatory Marker along Fence or Wall: The judge shall indicate with markers on arena fence or wall the center of pattern. Judge shall also place markers on fence or wall at least 50' from each end of the arena.

Ride pattern as follows: Trot to center of arena and stop or walk before departure. Start pattern facing toward judge.

1. Beginning on right lead, complete three circles to the right - the first two large and fast; the third one small and slow. Change leads at center of arena.
2. Complete three circles to the left - the first two large and fast; the third one small and slow. Change leads at center of arena.
3. Begin a large circle to the right, but do not close this circle. Run down center of arena, past the end marker, and do a sliding stop.
4. Complete 3 1/2 spins to the right.
5. Run up center of arena to the opposite end, past the end marker, do a sliding stop.
6. Complete 3 1/2 spins to the left.
7. Run back to the middle of the arena, past the center marker, and do a sliding stop. Back up at least 10 feet. Hesitate to show completion of pattern.