

CIMR 2000 PHU WARRANTY FORM

Customer Information:

Name _____

Address _____

Phone # _____

Distributor Information:

Name _____

Phone _____

UNIT: CIMR 2000 PHU

Serial Number _____

Date of Purchase _____

PLEASE COPY AND FILL OUT ALL INFO
RETURN IMMEDIATELY
MAIL, FAX OR EMAIL TO:

Hi-Tech Air Purification Systems
dba CIMR Technology
105 Magnolia Lane
Silsbee, TX 77656

Fax (866) 821-5569
customer.service@hitechllc.com



CIMR 2000 Personal Home Unit Owner's Manual

Continuous Infectious Microbial Reduction

CIMR™ Infection Control Technology makes New Infection Control Strategies possible for medical facilities, businesses of all sizes, educational institutions, government, mass transportation, and the hospitality industry.

It has been demonstrated to be effective against every virus, bacteria, mold, and other fungus against which it has been applied to date, including the H5N8 virus, MRSA (Methycillin Resistant Staphylococcus Aureus), nonresistant Staphylococcus Aureus, E-Coli, Listeria Monocytogenes, Stachybotrus Chartarum (Black Mold), Streptococcus, Pseudomonas, and Bacillus Subtillus.

Congratulations

You have purchased one of the most effective, technologically advanced air purifiers available. Your new CIMR 2000 PHU is designed to provide years of trouble-free, low maintenance operation. Be sure to read and follow all service procedures outlined in this owner's manual, and to use only genuine CIMR replacement parts available from your Distributor.

If you have any questions concerning this product, please contact your CIMR Representative.



Warning! – Do not operate this unit without the rear lint screen AND back cover installed.



Caution: To reduce the risk of electric shock, this equipment has a grounding type plug that has a third (grounding) pin. This plug will only fit into a grounding type power outlet. If the plug does not fit into the outlet, contact qualified personnel to install the proper outlet. Do not alter the plug in any way.



CAUTION! – Do not operate unit near heat sources, open flame, or combustible vapors or gases.

CAUTION! – Disconnect power cord before servicing.

NOTE: Use a 1.6 Amp slow blow fuse only.

Your CIMR Technology Representative :

Name: _____

Phone: _____

Warranty Information

This product is of solid state construction and is under warranty by:

Hi-Tech Air Purification Systems

www.cimrtech.com

Phone 866-231-3687

To the original purchaser, to be free from defect in materials and workmanship for a limited time.

Terms: Hi-Tech technology products with valid serial numbers are under warranty by Hi-Tech Systems, 105 Magnolia Lane, Silsbee, TX 77656, to the original purchaser only, to be free from defect in materials and workmanship for three (3) years from date of purchase, (excluding CIMR Cell which is under warranty for one (1) year from date of purchase and Remote Control units, if applicable, which are under warranty for 180 days from date of purchase). If a valid serial number is missing from a product, the warranty will be voided. To confirm warranty coverage prior to purchasing a product, contact the Company at 866.231.3687 with the serial number located on the back of the unit.

Hi-Tech products are authorized for sale through Independent Dealers only. Warranties are voided if a product is purchased through unauthorized channels. The Company will not extend warranty coverage on any product sold in a manner that violates our Internet Advertising Guidelines. This includes websites that are not authorized to use our trademarked names, images, and logos, as well as Internet auction sites. The only approved Internet presence for Hi-Tech products is the Company's corporate web address, www.cimrtech.com.

The Company's liability under this Warranty shall be limited to repair, or at our option, replacement without charge, except for transportation. All transportation charges on parts or units submitted under this Warranty shall be borne by purchaser. Unless this Warranty is expressly renewed or extended by the Company, any repaired or replaced part of the unit shall be under warranty to the original purchaser only, for the length of the unexpired portion of the original warranty.

The Company makes no warranties, express or implied, with respect to our Products, except such written warranty or warranties as may be set forth herein. SUCH WRITTEN WARRANTY IS EXCLUSIVE AND, TO THE EXTENT PERMITTED BY LAW, the COMPANY DISCLAIMS ALL OTHER WARRANTIES, INCLUDING BUT NOT LIMITED TO A WARRANTY OF MERCHANTABILITY OR FITNESS OF PURPOSE. NO CONSEQUENTIAL DAMAGES, INCIDENTAL DAMAGES OR OTHER INDIRECT OR SPECIAL DAMAGE OR LOSS OF GOODWILL, LOSS OF BUSINESS OPPORTUNITY, LOSS OR USE OF PLANT OR EQUIPMENT, OR LOSS OF EXECUTIVE AND EMPLOYEE TIME, WILL BE RECOVERABLE AND ARE SPECIFICALLY DISCLAIMED. THIS LIMITATION OF LIABILITY AND REMEDY REPLACES ANY AND ALL THEORIES OF ACTION, CAUSES OF ACTION, OR THEORIES OF DAMAGE WHICH MAY BE HAD OR BROUGHT, INCLUDING BUT NOT LIMITED TO ACTIONS BASED ON STATUTE, CONTRACT, BREACH OF WARRANTY, NEGLIGENCE, STRICT LIABILITY OR OTHER TORT THEORY. Some states do not allow the exclusion or limitation of incidental or consequential damages, so the above limitation or exclusion may not apply to you.

This Warranty gives you specific legal rights, and you may also have other rights, which vary from state to state. If your unit is defective, please contact Hi-Tech @ 105 Magnolia Lane, Silsbee, TX 77656, 866.231.3687 or www.cimrtech.com. Please copy and mail, fax 866.821.5569, or email your Warranty Card Information to Hi-Tech within 10 days of purchase for activation of warranty.

FCC Declaration of Conformity

Model: CIMR 2000

This device complies with Part 18 of the FCC Rules.

Troubleshooting –

1. I have plugged in the unit, pressed the ON button on the remote (or the unit), and nothing happens... what's wrong?

- Make sure the power cord is inserted completely into the receptacle on the back of the unit
- Make sure the electrical outlet is capable of providing power to the unit.
- Make sure the rear lint screen and back cover are properly installed.
- Check to see if the proper fuse is installed and that it is operational.

2. The UV lamp is not functioning/I'm getting a "Replace RCI Cell" message... what's wrong?

- Check cell for proper installation.
- Replace the cell.

3. What are the most typical application problems?

- Symptom: A belief that the proper equipment is placed in the environment and the equipment appears unsuccessful.
Problem: Lack of air movement, improper placement of the unit.
- Symptom: Strong odors still remain within the environment after placement.
Problem: Improper placement of the unit or the source of the odor has not been eliminated.
- Symptom: Visual haze of smoke and/or particulate remains within the environment.
Problem: Lack of ionization and/or air movement.

4. Air flow is restricted or reduced.

- Is the unit properly placed away from objects that may obstruct air flow?
- Are the rear lint screen, back cover, and front grill clean?
Is the CIMR/RCI cell clean?

5. How can I tell if the CIMR/RCI cell is functioning?

- The cell will produce a glow that is visible through the front grill under low light conditions.

6. Unit does not operate.

- Is the unit plugged in?
- Are you sure the outlet is active?
- Is the main switch turned on?
- Are the rear lint screen and back cover installed properly?
- Does the fuse need to be replaced?

Table of Contents

Unit Features	4
Specifications	5
Changing the Fuse and Maintenance	6
Settings and Adjustments	7
Removing the Lint Screen	7
Removing the Lint Screen (cont)	8
Removing the Cell	9
Troubleshooting	10
Warranty Information	11
Warranty Form	12

CIMR 2000 PHU with Dual Cell Capability

Your CIMR 2000 PHU comes with two (2) CIMR cells installed. If both lights are not lit, press and hold the Purifier button for approximately 15 seconds. The display will then indicate that both cells are activated. Press the Purifier button once to activate one cell, and twice to activate both cells.

Unit Features:

Front of Unit

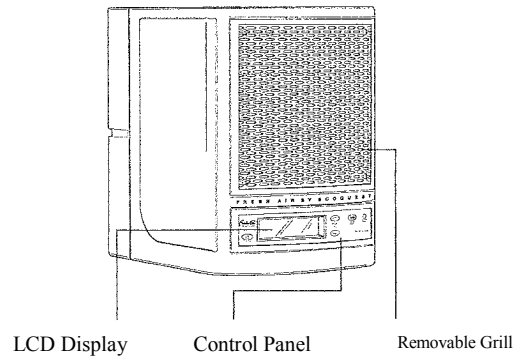

Rear of Unit

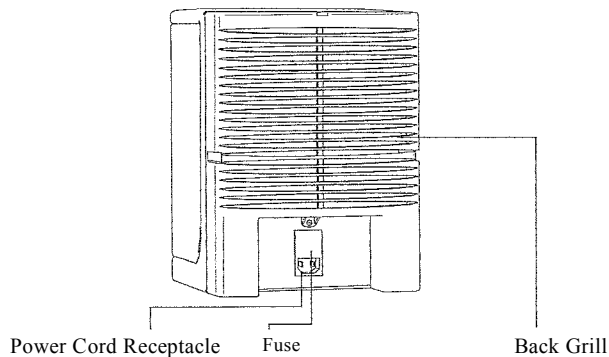

Removing the CIMR/RCI Cell After removing the back grill and the lint screen:

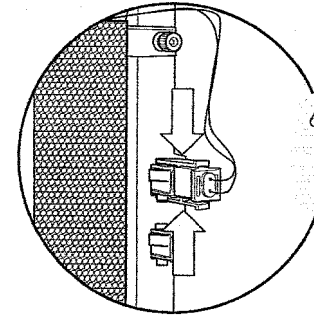

1. Unlock the cell connector by pressing on the connector's locking tabs.

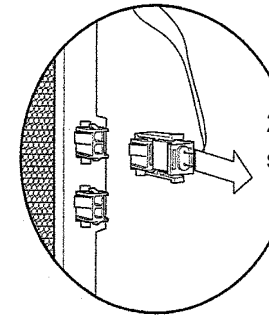

2. Pull the connector straight out to unplug.

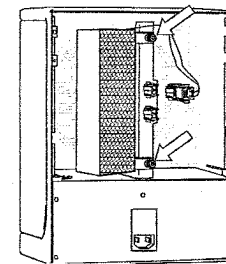

3. Remove two (2) thumb screws and remove cell.

To Install a new Cell, simply reverse steps 1-3.

CAUTION: Do not look directly at the glowing lamp. Prolonged exposure, even to reflected UV light, can cause eye damage according to the American Conference of Governmental Industrial Hygienist (ACGIH) Standards. CIMR 2000 emits UV light which can cause eye damage if the light were looked at continuously, for 20 minutes or more, at a distance of one (1) INCHES OR LESS.

DISPOSAL OF USED CELL:

Please do not throw a used cell into the garbage. The special germicidal UVX bulb used in the cell contains a very small amount of mercury. You may return your used cell to Hi-Tech for proper disposal. Send the used cell to:

Hi-Tech Air Purification Systems
105 Magnolia Lane
Silsbee, TX 77656

Removing the Rear Lint Screen (cont.)

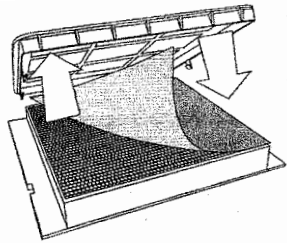

3. For first install, lay Optional Pre-Filter on unit filter. Replace with a new disposable Pre-Filter when performing monthly maintenance.

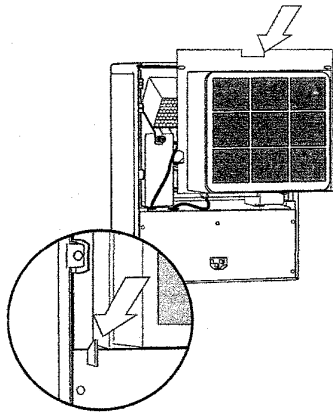

4. Replace the rear lint screen, inserting the bottom of the lint screen first.

Note: The bottom of the rear lint screen is held into place by two alignment guides (see inset).

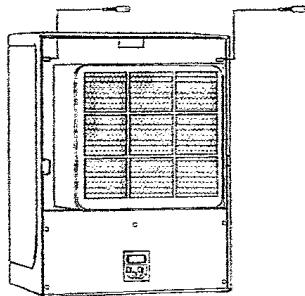

5. Secure the top of the screen by replacing the two (2) lint screen holder thumb-screws.

CAUTION! Always unplug the unit before performing any maintenance procedures.

Specifications:

Electrical:

100 volt 50/60 Hz, 120 volt 60 Hz, 220/240 volt 50/60 Hz based on country of use
80 watts power consumption
24 to 30 kV, 20-30 kHz ion generation pulsator
Fixed 6 kV DC needle ion generator

Size: Dimensions: 12" high x 9" wide x 12" deep Weight: 16 pounds

Mechanical:

70 CFM will vary depending on condition of rear lint screen

Coverage: Covers a range of 250ft² (23 m²) to 3000ft² (279 m²)**

**Depends on variables such as severity and frequency of pollution, humidity, and temperature.

Warranty: Length of warranty will vary depending on model. See warranty card for specific details.

General Operation

1. Adjust the fan speed to your preference, keeping in mind that higher fan speeds will give better results.
2. Using the PURIFIER button, set the unit to PUR. ON for increased effectiveness.
Pur. OFF - Only Fan and Ionization are on.
Pur. ON - CIMR Purification cell is also activated.

Placement of Unit

Place the unit as high as possible to insure complete purification, taking care to leave at least 1 inch of open area around the unit. Point the unit towards the center of the room.

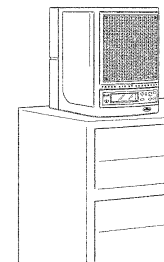

TO PREVENT INJURY, BE SURE THE POWER CORD IS NOT ACCESSIBLE TO SMALL CHILDREN.

Changing the Fuse

The fuse may be accessed by unplugging the cord from the back of the unit, removing the back cover, then pulling, or if necessary, gently prying the fuse out using a small, straight screw-driver. Use 1.6 slow blow fuse.

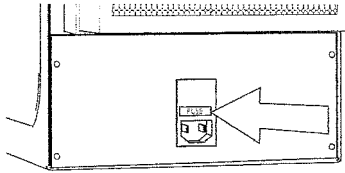

Maintenance Reminders

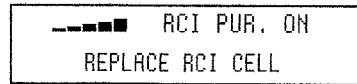

Replace RCI Cell - CIMR/RCI cell is no longer working correctly and needs to be replaced. See your dealer for replacement cell. NOTE: Cell needs to be replaced every **TWO** years whether the unit displays the message or not.

Perform Cleaning -

Clean the rear lint screen.

Vacuum (do not wash) the CIMR cell and the front and rear grill openings.

Wipe outer plastic surfaces with a soft, damp cloth, if needed.

After cleaning, be sure to press the “Reminder Reset” button located on the front control panel. The display will read “Cleared” when it is reset.

If you are operating your unit in a severely polluted environment, cleaning of the unit, CIMR cell, and rear lint screen should be done more frequently in order to keep unit running at top performance.

Caution: Unplug the CIMR 2000 before performing any maintenance procedures.

Settings and Adjustments

Your CIMR 2000 can be turned on or off and adjusted using either the included remote or the control panel on the front of the unit. With the exception of the Reminder Reset button, both the remote and the control panel buttons have the same functions.

Power (stand by)
CIMR 2000 can be turned on or off and adjusted using either the included remote or the control panel on the front of the unit. It turns the unit ON and OFF.

Fan UP/Fan DOWN
Adjusts the five speed fan.

Normal/High
Toggles the unit between PUR. OFF (Fan and ionization ON and
PUR ON (Fan and ionization ON, CIMR/RCI cell ON).

Reminder Reset (control panel only) Clears the maintenance reminders after performing routine maintenance

Optional Pre-Filter

CIMR Optional Pre-Filter is designed specifically for areas with tobacco smoke, multiple pets, or anywhere excessive levels of contamination are in the air.

Removing the Rear Lint Screen

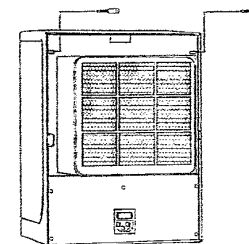

1. Remove the two (2) thumb-screws securing the top of the lint

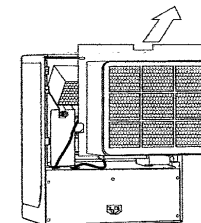

2. Remove the lint screen by pulling back the top and then lifting up and out.