

## Carter CT12 Pro 1.2 T Excavator Specifications

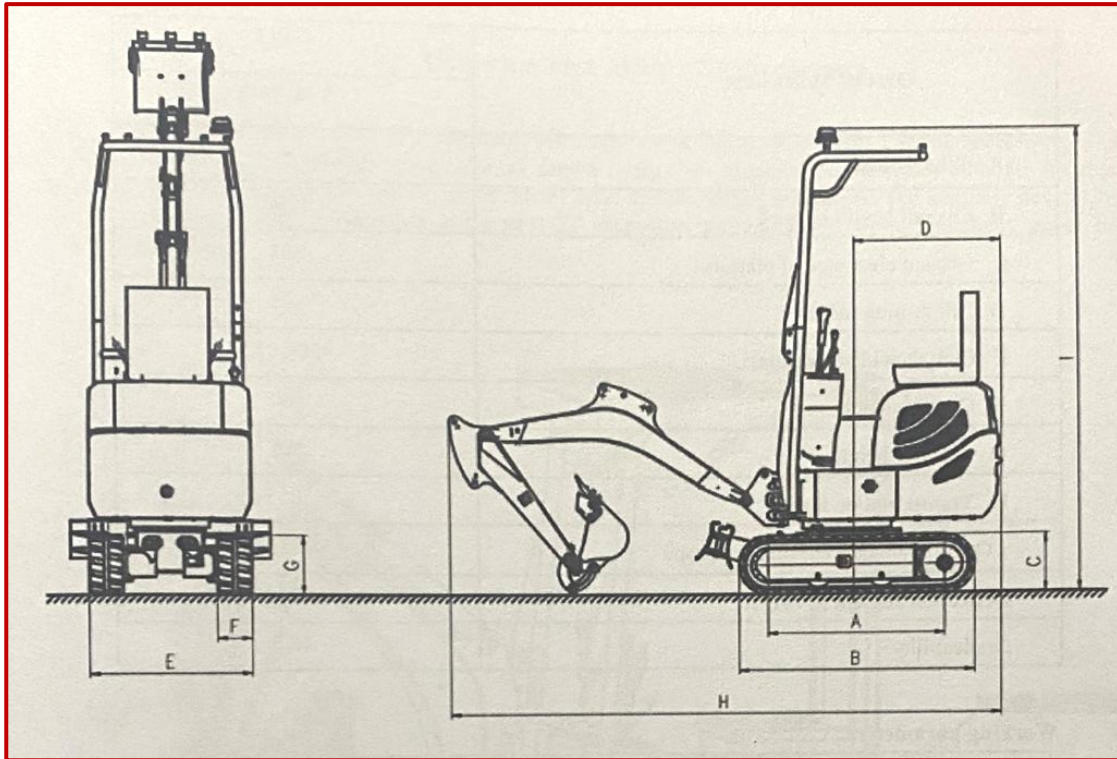

<u>Overall Dimensions</u>	<u>UNIT - mm</u>
<b>A. Wheel Track</b>	<b>972</b>
<b>B. Overall track length</b>	<b>1296</b>
<b>C. Ground clearance of platform</b>	<b>324</b>
<b>D. Tail turning radius</b>	<b>806</b>
<b>E. Chassis width (exp track)</b>	<b>850-1050</b>
<b>F. Track Width</b>	<b>180</b>
<b>G. Track Height</b>	<b>324</b>
<b>H. Transportation Length</b>	<b>3053</b>
<b>I. Overall Height</b>	<b>2588</b>
<b>Swing Boom Angle L° / R°</b>	<b>50 ° / 70°</b>
<b>Grade-ability</b>	<b>18.2</b>

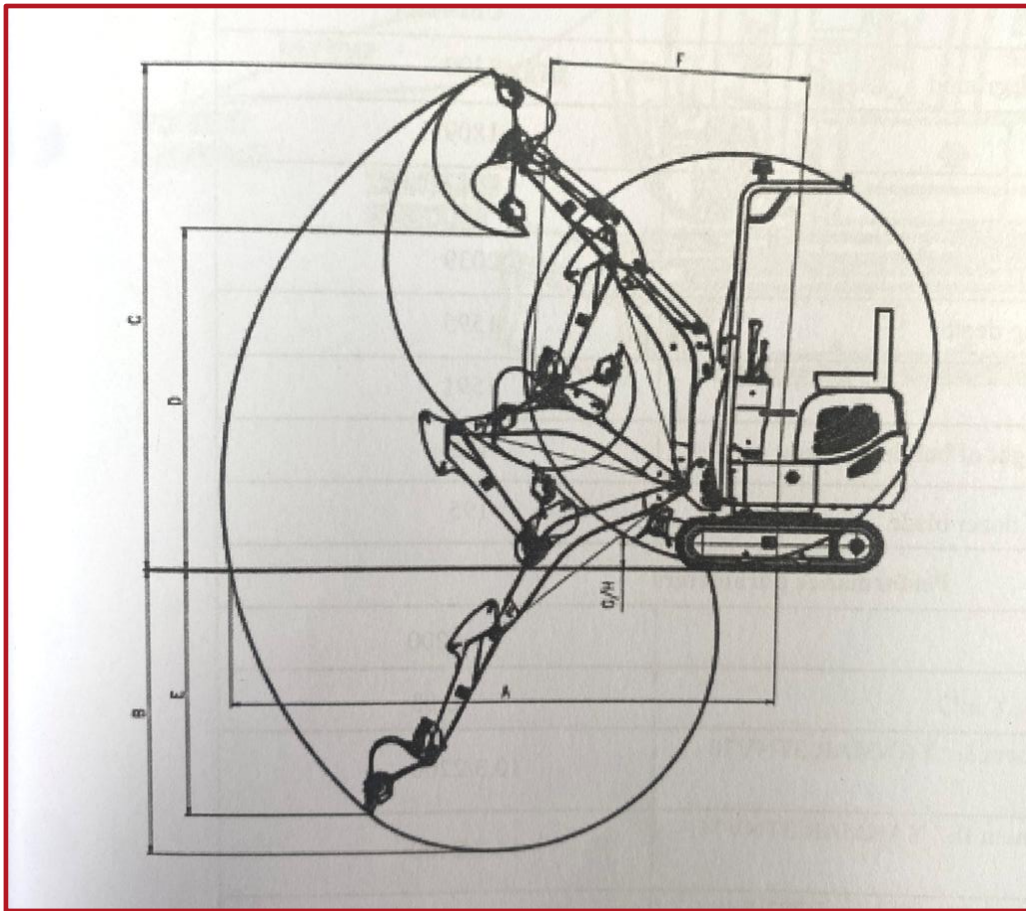

### Genuine Japanese Yanmar 3TNV70-S 3 Cylinder Engine

<u>Work Range</u>	<u>UNIT : mm</u>
<b>A. Maximum digging radius on the ground</b>	<b>3390</b>
<b>B. Maximum digging depth</b>	<b>1809</b>
<b>C. Maximum digging height</b>	<b>3018</b>
<b>D. Maximum unloading height</b>	<b>2039</b>
<b>E. Maximum vertical digging depth</b>	<b>1595</b>
<b>F. Minimum Swing Radius</b>	<b>1591</b>
<b>G. Max lifting height of blade</b>	<b>195</b>
<b>H. Max digging depth of blade</b>	<b>195</b>