

Catalogue

Chapter 1- Safety	1
1-1. Safety information	1
1-1-1. Recognize safety label	1
1-1-3. Compliance with safety regulations	2
1-1-4. Attachment Installation	12
1-2. Safety operation of the machine	14
1-2-1. Before starting the engine	14
1-2-2. After starting the engine	15
1-3. Safety and maintenance instructions	26
1-3-1. Carry out Safety and Maintenance	26
1-4. Warning signs and icons	31
1-4-1. Product nameplate	31
1-4-2. The position of the safety labels	32
Chapter 2-Components, Instrument and Controller	37
2-1. Name of components	37
2-2. Cabin	38
2-2-1. The Internal Parts of the Cabin	38
2-2-2. Display Screen	41
2-2-3. Fuel Gauge	42
2-2-4. Work light position	42
2-2-5. Start Switch	43
2-2-6. Throttle control lever	43
2-2-7. Horn switch	43
2-2-8. Pilot control switch lever(Safety operation lever)	43
2-2-9. Cup bracket	44
2-2-10. Cabin heating device	44
2-2-11. Cabin door release lever	44
2-2-12. Opening the front upper window	45
2-2-13. Close the front upper window	45
2-2-14. Open cabin door and window	46
2-2-15. Close cabin door and window	46
2-2-16. Adjust seat	46
2-2-17. Saftey Belt	46
Chapter 3. Machine Running-in	48
3-1. New machine running-in	48
3-2. Carefully observe the operation of the engine	48
3-2-1. Every 10 hours or every day	48
3-2-2. After the first 50 hours	48
3-2-3. After the first 250 hours	48
Chapter 4. Operation-Machine construction	49
4-1. Machine construction	49
4-2. Check the machine every day before starting	50
4-3. Check before starting the engine	51
4-3-1. Check the Level	51
4-4. Staring the engine	51
4-5. After starting the engine	52
4-5-1. Operating the machine in cold weather	52

Catalogue

4-5-2. Working in snow	53
4-5-3. Turning off the engine (stop) Steps	54
4-5-4. Inspection after turning off the engine.....	54
4-5-5. Preparation for moving machine	55
4-5-6. Driving machine cautiously	55
4-5-7. Taking advantage of pedal to drive the machine.....	55
4-5-8. Using the operating pole to drive	56
4-6. Walking.....	57
4-6-1. Controlling and operation of working device	59
4-6-2. Prohibiting operation	60
4-6-3. Walking on the slopes	62
4-6-4. Machine parked on the ramp.....	63
4-6-5. Parking machine	63
4-6-6. Operation in water or mud.....	63
4-6-7. Drag out from the mud.....	64
4-6-8. Operation in soft ground	64
4-6-9. Using boom and arm to raise one side track	65
4-6-10. Short-range pull out machine	65
4-6-11. Light load towing hook	66
4-7. The control lever	66
4-7-1. The pilot lever (safety lever).....	67
4-7-2. Control the speed of engine	67
4-8. Precautions of working.....	69
4-8-1. Safety operation machine	69
4-8-2. Recommend working.....	70
4-8-3. Avoid improper digging	71
4-8-4. Operating skills	72
4-8-5. Select the appropriate track shoe	72
4-8-6. The Precautions of parking the machine	72
4-9. Road transport	73
4-10. Loading machine	73
4-10-1. Loading.....	73
4-10-2. Transportation	75
4-10-3. Unloading.....	75
4-10-4. Machine lifting methods	76
Chapter 5. Maintenance	78
5-1. Maintenance Guide	78
5-1-1. Time meter.....	78
5-1-2. Carter genuine quick-wear parts.....	78
5-1-3. Carter genuine lubricating oil	78
5-1-4. Windshield washer fluid.....	78
5-1-5. Pure engine lurricating oil	78
5-1-6. Check the emission oil and used filter	78
5-1-7. Fuel pre-filter	78
5-1-8. Welding instruction	78
5-1-9. Avoid to drop things into machine interior	78
5-1-10. Dusty working place	79

Catalogue

5-1-11. Avoid mixing lubricating oil.....	79
5-1-12. Installation of Hydraulic hose.....	79
5-1-13. Check after checking and maintenance.....	79
5-2. Normal Maintenance and Inspection.....	80
5-2-1. Check time meter usually.....	80
5-2-2. Use the right fuel and lubricant.....	80
5-2-3. Preparation work before maintenance.....	80
5-2-4. Periodic replacement of parts.....	81
5-2-5. Check and tighten the track shoe's bolt.....	82
5-3. Maintenance Sechedule.....	83
5-4. Maintenance Period.....	85
5-4-1. 10 hours/every day maintenance.....	86
5-4-2. 50 hours/every week maintenance.....	91
5-4-3. 250 hours/every month maintenance.....	92
5-4-4. 500 hours/3 months maintenance.....	96
5-4-5. 1000 hours/6 months maintenance 1000.....	98
5-4-6. 2000 hours/every year maintenance.....	101
5-5. Electrical System.....	105
5-5-1. Battery.....	105
5-6. Replacement of bucket.....	109
5-6-1. Change bucket.....	109
5-6-2. Change bucket and connect to bucket.....	109
5-6-3. Adjust bucket connection.....	110
5-7. Track Check.....	112
5-7-1. Adjust Track droop.....	112
5-7-2. Loose track.....	112
5-8. Bolt and Nut Check.....	114
5-9. Maintenance in Special Situation.....	115
5-10. Machine Storage.....	116
5-11. Remove machine in storage.....	117
Chapter 6. Troubleshooting.....	118
6-1. Not failure's situation.....	118
6-2. Start engine with auxiliary cable.....	118
6-2-1. Connection and disconnection auxiliary cable.....	118
6-2-2. Connection of auxiliary cable.....	119
6-2-3. Start Engine.....	119
6-2-4. Disconnection of auxiliary cable.....	119
6-3. Troubleshooting.....	120
6-3-1. Engine.....	120
6-3-2. Electrical System.....	124
6-3-3. Hydraulic System.....	126
6-3-4. Control Lever.....	129
6-3-5. Mode selection.....	129
Chapter 7. Technical Parameters.....	130
7-1. Performance parameters.....	130
7-2. Digging Swing Range.....	131
7-3. Working range.....	132

Chapter 1- Safety

1-1. Safety information

1-1-1. Recognize safety label



- (a) This is the label of “safety”.
- (b) When you see this label on the machine or in this manual, you should be aware that it reminds of the risk of injury.
- (c) Please follow recommended precautions and safe practices.

1-1-2. Understand signal words

The safety signs on the machine which indicate the degree of harm DANGER, WARNING or CAUTION and the mark is used in conjunction with signs on the machine safety signs.



DANGER indicates a hazard with a high level of risk which, if not avoided, will result in death or serious injury. Safety signage is positioned on the particular hazard nearby.



WARNING indicates a hazard with a medium level of risk which, if not avoided, could result in death or serious injury. Safety signage is set in a particular crisis in the vicinity.



CAUTION indicates a hazard with a low level of risk which, if not avoided, may cause in minor or moderate injury. General precautions listed in the CAUTION safety signs. In the present manual, the IMPORTANT is also used to remind the attention to the safety instructions.



To avoid confusion between the machine protection and personal safety instructions, the signal word "important" is used to indicate a situation that may cause damage to the machine.

To do additional description of the individual important information.

1-1-3. Compliance with safety regulations



(A) Read and observe all safety signs carefully, machine and this manual all safety related issues in the safety signs marked on the machine and in this manual.

(B) When necessary, installation, maintenance and replacement of safety signs.

(C) If the safety signs or the manual is damaged or lost, by an order like the same method ordering spare parts to the specified sellers and CARTER Heavy for ordering them

(Order required specifying the model and serial number of the machine).

(D) Learning to operate and control the machine safely and correctly.

(E) Only trained and qualified personnel can be allowed to operate the machine.

(F) Keeping the machine in a suitable working conditions

(G) Make unauthorized modifications of the machine may be detrimental to its function and (or) security, and affect the life of the machine.

(H) The safety instructions in the "Security" chapter are basic safety instructions of the machine. However, these safety instructions don't involve all the dangerous situations you may encounter. If have any doubt, please contact with you specifies dealer or CARTER service engineer firstly before operating and maintaining of machinery.

1. Understand the safety equipment

(A) Ensure that all guards and cover are in the appropriate location. If the guards and the cover are damaged, please repair them immediately.

(B) Understand the method of using the safety device and use it correctly.

(C) Do not remove any safety devices, and to ensure that they remain in good working condition.

2. Keep machine clean



(A) If there is water in the electrical system it could cause the machine failure. Do not use water or the steam to flush electrical system such as sensors, connectors;

(B) When checking or maintenance, if the machine with mud or oil, it may result in the risk of slipping, falling and harming eye by dirty things. So please keep the machine clean

3. Keep cabin in clean

(A) When entering the cabin, be sure to remove dirt and grease under the shoes. The operation of the pedal with the shoes carrying mud or oil, the foot will slip which could cause a serious accident.

(B) Do not leave parts or tools in the cabin.

(C) Do not stick suction pad to the glass. Suction pad play the role of magnifying function, it may cause a fire.

(D) When driving or operating machinery, do not use a mobile phone in the cabin.

(E) Dangerous goods (such as flammable or explosive materials) should not take into the cabin.

4. To leave the seat in a locked condition

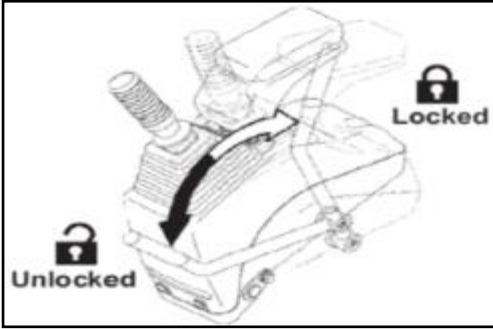

(A) Operator stood up from the seat, such as opening or closing the front Window or roof windows, or adjust the seat, has to make the work unit is completely lowered to the ground, the safety lock lever firmly pull into the locked position, and then turn off the engine. If the control joystick is not locked, and accidental touching the joystick, the machine may move suddenly and causing serious injury or damage to the machine.

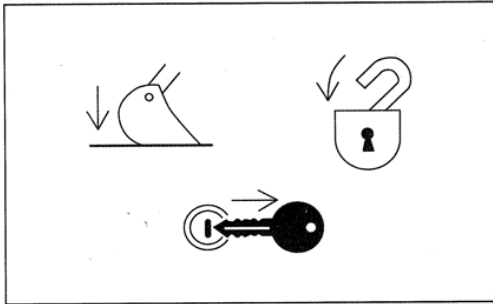

(B) When leaving the machine, be sure to operating device is fully lowered to the ground, Safety lock lever firmly pull into the locked position, and then closed engine. With a key to lock the device, then remove the key and placed in a predetermined position. .

5. Emergency preparedness

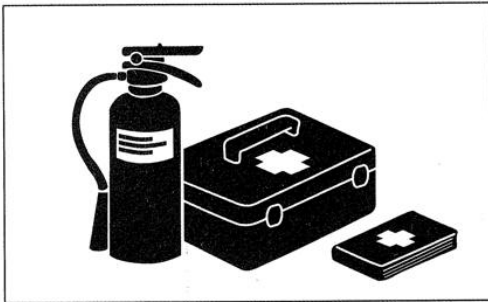

Take precautions against fire or accident

- (A) Prepared and placed first aid kit and fire extinguisher equipment nearby.
- (B) Carefully read and understand the instructions attached to the fire extinguisher and correctly use the fire extinguishers.
- (C) Make the emergency guide measures to deal with fires and accidents.
- (D) The telephone number of Doctors, ambulance, hospital, and fire department should be stuck by the phone.

6. Wear protective equipment

(A) Wear tight clothing and safety products suitable for work.



You may need the following safety products:

- Hard helmet
- Safety Shoes
- Safety glasses, goggles or face shield
- Heavy duty gloves
- Hearing protection
- Reflective clothing
- Rain gear
- Masks or filtration masks

(B) Always wear work clothes and safety supplies, do not leave things to chance.

(C) Avoid wearing loose clothing, jewelry or other things may be hooked by joystick.

(D) Safe operation of the machine requires the operator to concentrate. Do not listen to the radio or music while operating.

7. Noise protection

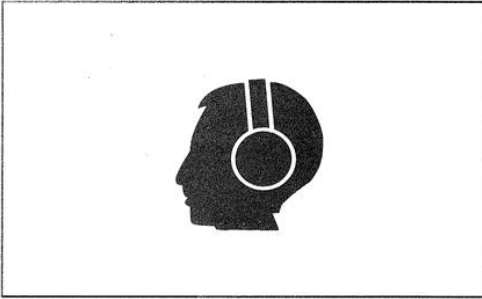

- (A) Prolonged exposure to loud noise can cause hearing impairment or loss.
- (B) Wear suitable hearing protectors, such as ear plugs to avoid harmful or strong unpleasant noise.

8. Check machine



- (A) To avoid personal injury, every day before starting the machine, check the machine carefully.
- (B) In the tour check carefully around the machine, be sure to “check before the start of the inspection” described in the chapter all.

9. Use handrails and ladders



Always observe this precaution to ensure safety!

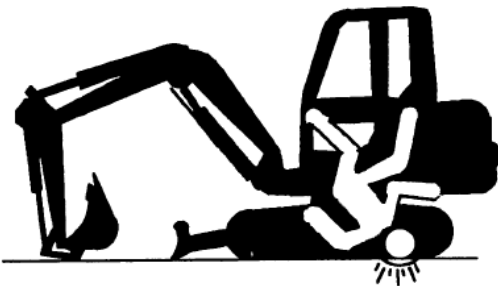

- (A) The drop is one of the main causes for personal injury.



- (B) Up-and-down the machine, always with the pedal and handrails to maintain three points of contact, and machine-oriented;
- (C) Do not put any lever, the cabin door handle as a handrail;
- (D) Can not jump on/off the machine, and do not get on/off the moving machine;
- (E) When using the machine, pay attention to the platform and handrails slippery;
- (F) Oil, mud and water in handrails and shoes should be cleaned any time.

10. Adjust the position of the seat



- (A) Uncomfortable seat is likely to cause fatigue, leading to operational mistake;
- (B) In each exchange machine operator, and should be re-adjust the position of the seat;
- (C) When the operator back on seat back, you should be able to step on the pedal to the end, and correct the operation of the joystick. If not, move forward and backward seat, re-adjust;

11. Fasten seat belts

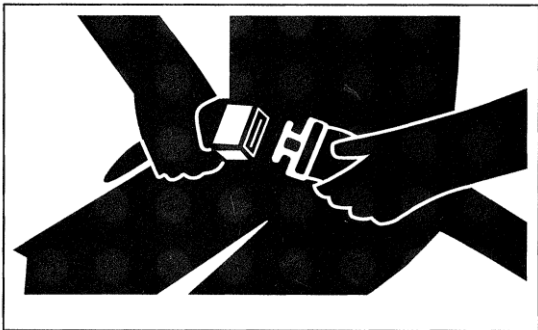

- (A) In the case of a rollover accident, the operator may be injured or throwing out of the cabin, or may be pressing down by the machine, then cause serious injury or death;
- (B) Before operating the machine, check the seat belts, buckles and solid set pieces carefully. If you find any damage of the seat belts, it should be replaced before operating.;
- (C) While operating the machine, be sure to sit on the operating chair and fasten your seat belts, in order to minimize the possibilities of accident injuries;
- (D) Best to replace seat belt per three years, no matter what condition it is.

12. Not-allowed to get on/off the machine at will

- (A) Do not jump on/off the machine when it's moving;
- (B) If the machine begins to move in the absence of the operator, do not jump on the machine and tried to stop it.

13. Not allowed to sit on the machine at will

Do not allow anyone sitting on a bucket or other attachments, or it may falls and cause serious injury;

14. Windshield washer fluid

Use ethanol-based washing liquid to clean the windshield. Do not use methanol the base washing liquid, otherwise it will stab your eyes.

15. Cabin window glass

- (A) If the glass at the working device side of the cabin is broken, there is risk of the working device coming in direct contact with operator's body, so stop the operating immediately and replace the glass.
- (B) If the damage to the roof window made of Plexiglas (polycarbonate), they will explode and lose their protective function; roof window has been damaged by a falling rock or burst, be replaced with a new window.

16. To ensure a good vision

Safety—Safety Information

- (A) To ensure safe operation or walking, to check if anyone in the area around the machine or disorders and workplace;
- (B) When working in a dark place, turn on work lights and headlights on the machine, if necessary, set the auxiliary lighting in the work area.
- (C) If the vision is not good, as fog, snow, rain or dust, to stop the operation.

17. View the Construction site in advance

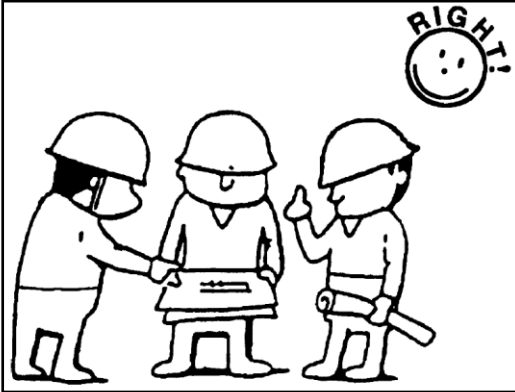

- (A) When working on the side of ditch or the road shoulder, the machine can turn over; this will cause serious injury or death.
- (B) Prior to survey the terrain and ground conditions of the site, in order to prevent the machine to tip over or fall, or even the ground, stockpile or the river bank collapsed.
- (C) The development of operational plans to use the machine for your job or site.
- (D) As required reinforcement the ground, ditch side and road shoulder, to ensure a safe distance between the machine and ditch and road shoulder.
- (E) When operating in diagonally or shoulder of the road, according to need to arrange signalman command.
- (F) Before starting work local in trust between soft, must be reinforced ground.
- (G) Operations on the frozen ground, to be especially vigilant. Because the ambient temperature rise to causes the ground to become soft and slippery.

18. Prevention of falling stones and gravel

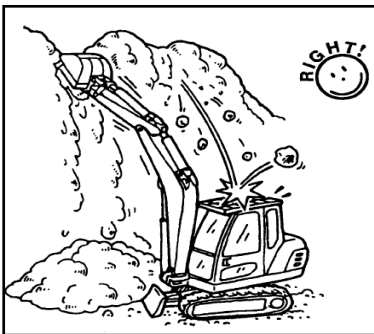

- (A) Work in the condition where may fall rocks or stone, to ensure that the cabin is equipped with falling object protective net;
- (B) Wear a helmet and protective eyewear;

19. Multi-machine operation signaling



In the case of multi-machine operation so that all workers unified signal, specify a signalman to organize the job, while ensuring that all workers obey the command;

20. signalman signals and gestures

- (A) To set the flag on the shoulder or soft ground. If the **vision** is not good, if necessary, arrange for a signalman command. The operator should pay particular attention to the signs, and obey the command of the signalman.
- (B) Only signaled by one signalman.
- (C) Before starting work, ensure that all operators are aware of all signals and gestures.

21. Keep away from rotating parts

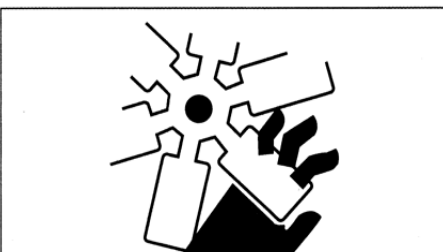

- (A) It maybe results in serious injury if caught in moving parts.
- (B) Working next to the rotating member, need to be very

careful of hands and legs, clothes, jewelry and hair so that will not rotating member involvement.

22. Prevent parts flying out



The track adjusters grease usually in the high pressure, if not avoided the following precautions may result in serious injury, blindness or death.

- (A) Do not remove the grease fitting or valve parts.
- (B) Parts could come out of, so the body and face should be away from the valve body.
- (C) Walking reducer with pressure.
- (D) As part could come out, so the body and face must be away from the air drain plugs, to avoid injury.
- (E) Because the gear oil is hot, gradually release air emissions tied to wait for gear oil cooling, the pressure was released.

23. Prevent falling objects, flying objects and invader



- (A) Falling objects, flying objects and invader hit or enter the driving cabin dangerous workplaces, depending on the operating conditions; security mounted the necessary shield to protect operating personnel.
- (B) When the removal or crushing operation, to install the front shield, and posted the front glass transparent cellophane.
- (C) When the risk of falling rock mine or quarry operations, to install FOPS (Falling Object Protective Structure) and the front shield and posted in the glass transparent cellophane.

- (D) When the operation to close the front window. Further, to ensure that other persons out of the danger zone, and keep a safe distance.
- (E) Above described is for typical conditions, according to the site operation, you may need to install other guard. When any part of the protection structure, like ROPS, FOPS, and TOPS (rollover protection structure), and so on appear the plastic deformation or fracture (for example, subject to due to roll, Falling Object shocks or tipping) , please contact with CARTER Heavy Industry dealer in a timely manner, the protective structure has to be replaced according to manufacturer's specifications.

24. To prevent burns

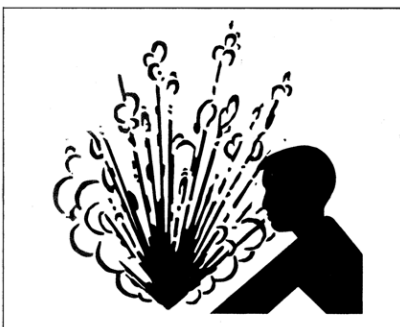

- (A) The discharge of the high temperature liquid:

- After operating machine, the cooling water of the engine is hot and with pressure. If the skin is exposed to a spill or spray of hot water or steam will cause serious burns
- When the engine is hot, do not open the radiator Cover, and first slowly rotate the lid to be fully

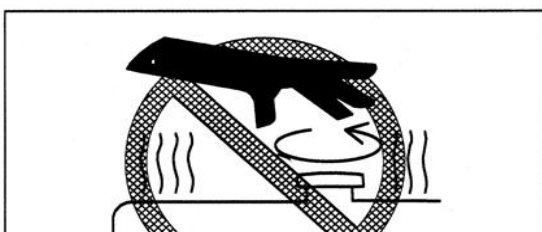

Safety—Safety Information

released off the pressure, then remove the cover and release the pressure.

- Hydraulic tank is pressurized to ensure release the pressure before the lid is removed.



(B) High-temperature liquid and surface:

- In operation, the engine oil, gear oil and hydraulic oil will become hot. Engines, hoses, tubing, and its parts become hot. It should wait until oil and component cooling only after inspection or maintenance work.

25. Prevent falling

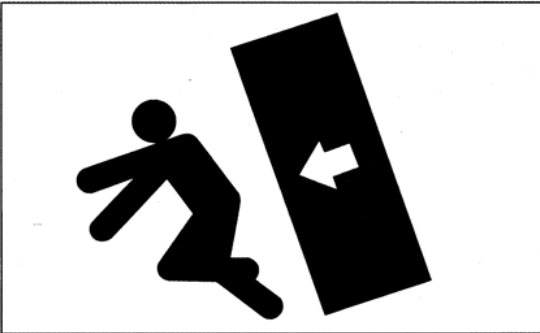

- (A) Storage of accessories, such as a bucket, May topple over, resulting in serious injury or death.
- (B) Safely store accessories and machinery to prevent falling. Children and other non-essential personnel should stay away from the storage area.

26. Be careful high-pressure liquid

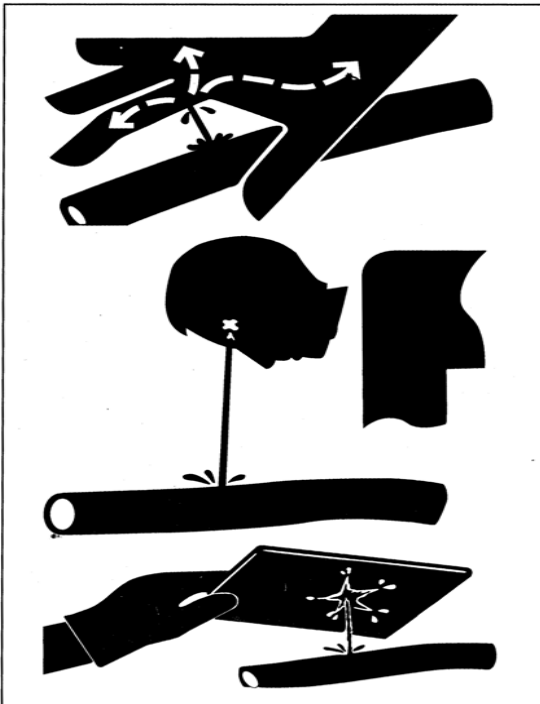

- (A) Pressure injection diesel oil, hydraulic oil, liquid penetrate the skin or injected into the eye, resulting in serious injury, blindness or death. Therefore, before demolition hydraulic or other pipeline must release the pressure in order to avoid these dangers.
- (B) Tighten all the links before increase the pressure.
- (C) With cardboard to find if it is leak, pay attention to protect your hands and body free from exposure to the high-pressure liquid. Wear a face shield or goggles to protect the eyes.
- (D) If an accident occurs, immediately accepted professional surgeon treatment. Any liquid in to the skin must be surgical remove in several hours; otherwise it will lead to gangrene.

27. Prevent fire



(A) Check the oil spills

Safety—Safety Information

- Fuel oil, hydraulic oil and grease leaks may cause fire disaster.
 - Check whether the holder is missing or loose, the hose is twisted Knot, or hose, piping friction between oil cooling is damaged, and oil cooler flange bolts are Relaxation, in order to avoid oil spills.
-
- The tightening, repair or replace any missing, relaxation or damage the holder, piping, hoses, oil cooler and its law blue bolt.
 - Do not bend or strike high pressure lines.
 - Do not install bent or damaged pipe, tube or hose.
- (B) Check the short circuit**
- A short circuit will cause a fire.
 - Clean and tighten all circuit connections.
 - In each shift before or after 8-10 hours of operation, check the cable and wire is loose, kink, hard or cracked.
 - Before each shift, or 8-10 hours after the operation, then check stud end cap is lost or damaged.
 - Do not operate the machine if cables or wires relaxed and kinked.
- (C) Clear combustibles**
- Spilled fuel and hydraulic oil, garbage, grease, broken debris and other combustible materials may cause a fire. Check and clean machine every day, promptly remove spilled or accumulation of combustible material, to prevent fire.
- (D) Check the key switch**
- Fire if not stop the machine, it will increase the fire situation is not conducive to the fire. Daily before operating the machine must to check the function of the key switch, to start the engine, in order to idle speed no-load operation, the key switch to OFF position, and confirm whether the engine is came to a halt or not.
- (E) To prevent lighting equipment cause an explosion**
- When checking the fuel, oil, battery electrolyte, windows Washing-up liquid coolant, to use explosion-proof lighting equipment. If not use this kind of lighting equipment, the explosion caused serious injury.
 - When the power of the machine used for lighting, to comply with the prescribed instructions.
- (F) Check the heat shield**
- Shrouds damage or loss may cause a fire.
 - If any abnormalities are found, make sure before operating the machines Repair or coupled with new heat shield.

28. Measures in the event of fire

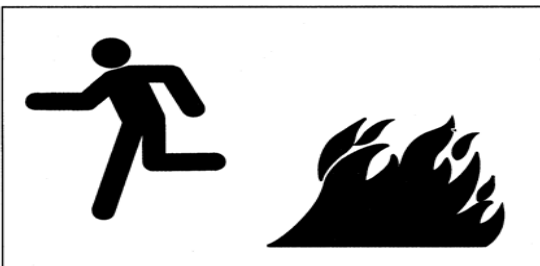

- (A)** If the fire breaks out, evacuated machines as the following:
- If time permits, switch the key to the OFF (off)
 - If time permits, use of fire extinguishers.
 - leave the machine right away.
- (B)** In case of emergency, if not open cabin or the front window, take the hammer and break the rear or side glass, to escape from the cabin.

29. Avoid heating near the hydraulic lines



Flammable spray will be burned in the vicinity of the pressure tube heating, which will lead to you and others next

to you severely burned.

- Do not welding, soldering or gas welding nearby the hydraulic pipe or other flammable materials.
- When Burning over directly combustion area, the hydraulic pipe may be cut off at any time. The machine should be install temporary jacket to protect hoses or other materials while welding, soldering and other operations.

30. Avoid heating pipes where there are flammable liquids.

- (A) Do not welding or gas cutting pipes or hoses where contain flammable liquid.
- (B) Before welding or gas cutting pipes, completely cleared flammable liquid with non-combustible solvent.

31. Remove the paint before welding or heating

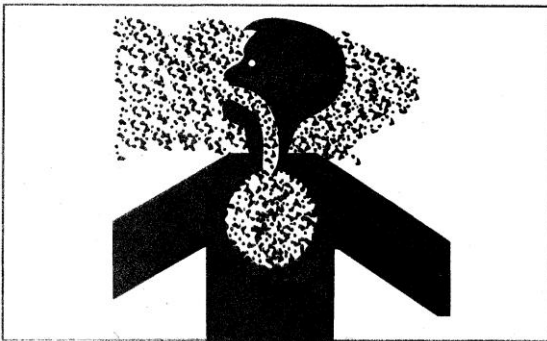

- (A) Paint may produce harmful gases in welding, soldering, or using the gas torch; inhalation of these gases can cause nausea.
- (B) Prevent to producing potential toxic gases and dust.
- (C) Removal paint in outdoors or in a well-ventilated place. Correct disposing of the paint or solvent to protect the environment.

(D) Remove the paint where need to weld or heat:

- Wear respirator to prevent inhalation of dust, if using sandpaper and grinding wheels to remove the paint.
- Using Soap liquid to remove the paint or varnish removers before welding if you use solvent or varnish removers to remove the paint. Clear the solvent or paint remover's containers and other flammable materials in the working area. Waiting at least 15 minutes before heating or welding for dispersed the volatile gas.

32. Prevent battery exploding

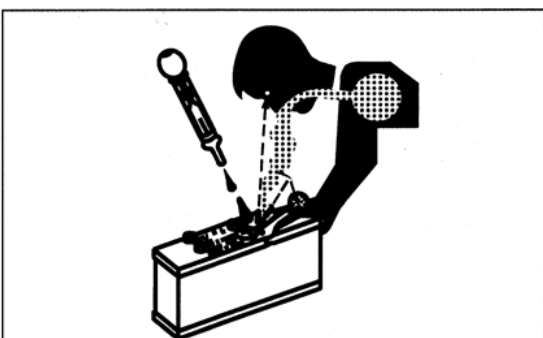
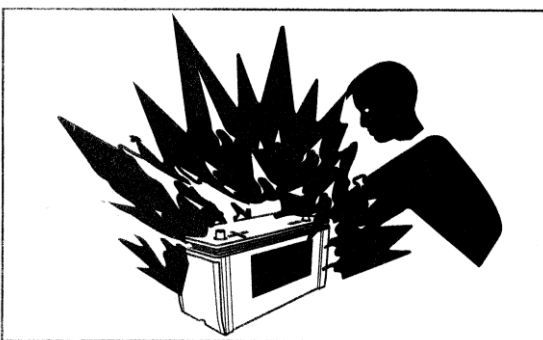

- (A) Battery gas could explode.
 - Avoid sparks, lighted matches and flame close to the top of the storage battery .
 - Using a voltmeter or aerometer to check up the battery power, not use the method of placing a metal contact the electrode.
 - Do not charging to the frozen battery, otherwise it would cause explosion. The battery should be warmed to 16°C.
- (B) Electrolyte of battery is poisonous. If the battery were exploded, battery electrolyte is splashed into the eyes which could lead to blindness.

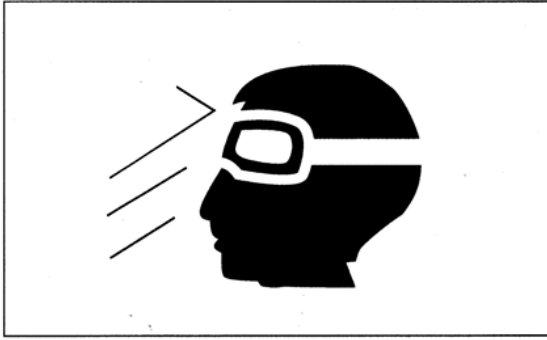

(C) Be sure to wear goggles when checking the specific gravity of electrolyte.

WARNING

If the Sulfuric acid were spilled on the body accidentally, should process as follows:

- First, flushing skin with water.
- Then, using soda or lime to neutralize the acidity.
- Addition, rinsing with water for 10-15 minutes and seek medical advice immediately.

Fobid to wash the battery directly, wipe the battary when cleaning.

33. Ventilating of the closed area



- If must start the engine in a closed area, or disposing of fuel, cleaning oil or paint, be sure open the door and windows to adequate ventilation to prevent gas poisoning.

34. To prevention the risk of asbestos dust

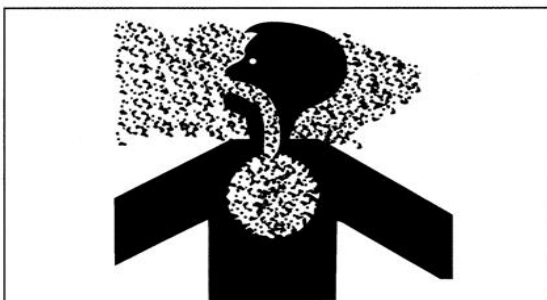

- (A) If inhaled asbestos dust in the air were caused lung cancer. When engaged in demolition work in the workplace or treatment of industrial waste, it has the dangers of asbestos inhalation. Be sure to observe the following rules.
- When cleaning, water sprays dust suppression, do not use compressed air to clean.

- If there are asbestos dust in the air, must be in the limelight position to operate the machine, all personnel should use qualified dust masks.
- Other people should not be close to the machine when working.
- To comply with regulations, rules and environmental standards in the workplace.

(B) This machine does not use asbestos, but counterfeit parts may contain asbestos, so be sure to use CARTER spare parts.

35. Safety handling the chemicals



Direct contact with harmful chemicals on the human body can cause serious injury. The chemicals used in the present machine,

Safety—Safety Information

such as lubricants, coolants, paints, and a binder, may be harmful.

- Material Safety Data Sheet provides the details of the chemicals on the human body and health hazards, safety procedures and emergency measures.
- Before using the hazardous chemicals should be verified with the data table, so will be able to really understand the danger, and know how to conduct security operations, and then work in accordance with the procedures using the recommended tools.
- Chemicals Safety Data Sheets (MSDS) which used in machine should be obtained from the local dealer and the service division of CARTER.

36. Proper waste disposal

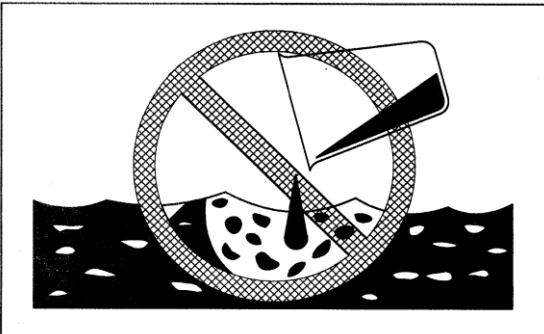
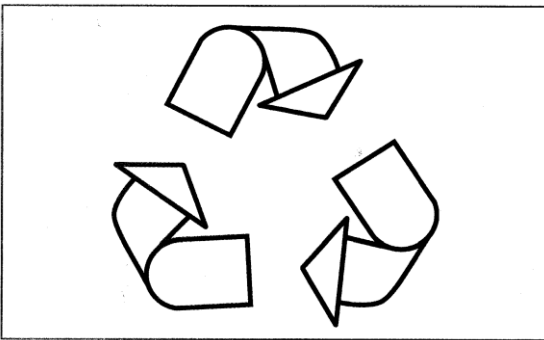

(A) Disposing the waste improperly may harm to the environment and ecological .The potentially hazardous waste in CARTER heavy equipment, including hydraulic oil, fuel, coolant, refrigerant, filters, and batteries and other items.

- In the discharge of liquid, should be use leak-proof containers. Do not use food or beverage containers, because it may lead to accidental ingestion.
- Do not pour the waste into the ground, sewers, or poured into any water source.
- Refrigerant leak into the air can destroy the Earth's atmosphere. Government regulations require a certified air conditioning service center to recovery and recycling of refrigerant.

(B) Inquire local environmental, recycling center or your dealer about the correct ways of how to recovery or disposal of waste.

1-1-4. Attachment Installation

- (A) When installing the optional accessories, exist security or legal constraints, so please contact with CARTER dealer in advance.
- (B) CARTER is not responsible for the injury caused by using of unauthorized accessories or parts.
- (C) When installing and using the optional accessories should read the accessories manual or manual attachment.

1. Attachment Combination

- (A) Different types or combinations of the working apparatus may cause the risk of collision the driver's cabin or other components of the machine.
- (B) Before using unfamiliar working device, please check whether there is the risk of interfering with each other, and work carefully.

2. Unauthorized modification

- (A) Before modification you should have to contact with CARTER dealer. Any modification without approval of

Safety—Safety Information

CARTER will cause dangerous.

- (B) In the case of without the approval of the CARTER, for any harm caused as a result of the modification, accident or product failure, CARTER assumes no liability whatsoever.

1-2. Safety operation of the machine

1-2-1. Before starting the engine

1. The check before starting the engine

- Wipe away the dust on the surface of the window glass, to ensure a good **vision**.
- Clean the headlights and work lights well, and check whether they are normal.
- Check the coolant level, fuel level and engine oil sump oil level.
- Check the air filters if it is blocked, and check the wires for damage.
- The seat adjusted to the easy operation, and checks the seat belt or the retaining clips damage or not.
- Check that the instrument is working properly, check the light and the angle of the lights and check the control lever is all in the middle position.
- Adjust the rearview mirror, so that you can clearly see from the seat and the back of the machine.
- Make sure there are nobody and barrier around the machine.

2. Safety regulation for starting the engine

- (A) When starting the engine, honking for warning.
- (B) Only allows the driver to start or operate machine.
- (C) In addition to the operator, does not allow anyone on the machine.
- (D) Not allowed to start the engine by the way of which cause the starter motor short circuit, doing so is not only dangerous, but also cause damage to the equipment.

3. Starting engine in cold weather

- (A) To complete warm-up operation. If the machine before operating the joystick does not warm up thoroughly, there will be unresponsive, resulting in accidents.
- (B) If the battery electrolyte is frozen, not to charge the battery or use a different power to start the engine, otherwise the battery will be the risk of fire.
- (C) Charging or with different power before starting the engine, make the battery electrolyte melt, before starting to check the battery electrolyte freezing and disclosure.

4. Safety removes and operate machine

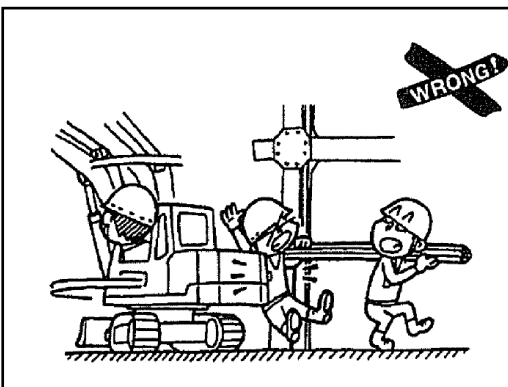

(A) Surrounding personnel are likely to be knocked down

- Especially careful not to knock down around the staff, before moving, rotating or operating machinery, recognized around the location.
- Always keep walking alarm horn (option) in working condition. When the machine begins to move, they can warn around personnel.
- Walking in the narrow area, rotary or operating machinery arrangement signalman command, before you start the machine, to coordinate the meaning of the gesture signal. The signalman was the only, and shall not at the same time more than two signal officer commanding.

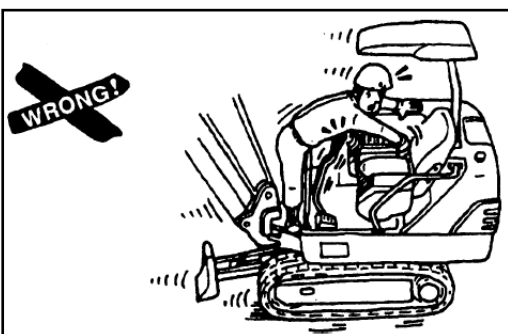

(B) Sitting in the operating chair

- Only start the engine in the operating chair
- Never stand in the track above the ground to start the engine.
- Before starting the engine, confirm that all the joystick in the middle position

⚠ WARNING

The incorrect engine start procedure will cause the machine out of control, could result in serious injury or death.

⚠ CAUTION

The safety lever only in the locked position to start the engine, you can not start the engine in the unlocked position.



(C) Jump start

- Battery gas may explode and cause serious Casualties.
- If you must jump start the engine machine, be sure to comply with the "operating the engine in the chapter. this requirements need two people to carry.
- Never use a frozen battery
- Failure to observe proper jump start step will result battery explosion or loss of control of the machine

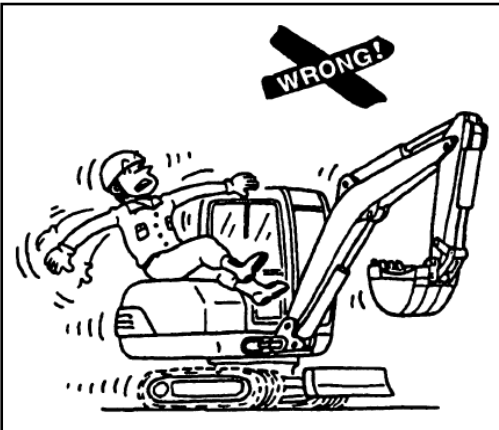

(D) To avoid machine equipped with crew

- Only allow the operator on the machine, do not allow other multiply member.
- The crew will also block the vision of the operator, resulting the unsafety of the operation.

⚠ WARNING

The crew on the machine is vulnerable to injuries, for example, hit by foreign objects or thrown from the machine.

⚠ CAUTION

The decorative Vice seat in the cabin allows equipped with a ride staff.

1-2-2. After starting the engine

1. After starting the engine check

- (A) When doing inspection, moves the machine to a wide area without any obstacle, and slowly operates the machine, does not allow anyone close to the machine.
- (B) Be sure to fasten your seat belt.
- (C) Inspect the operation of instruments and equipment is functioning properly, and check the bucket, stick, boom, travel system, rotary system. And the steering system is operating correctly.

Safety — Safety operation of the machine

- (D) Check the machine's sound, vibration, heat, smell or instrument whether there is abnormal, check the oil or fuel leaks.
- (E) If any abnormality is found, to be repaired immediately.
- (F) To be maintenance, switch the safe operation lever to the LOCK position and suspension overhaul signage.

2. Machine Direction

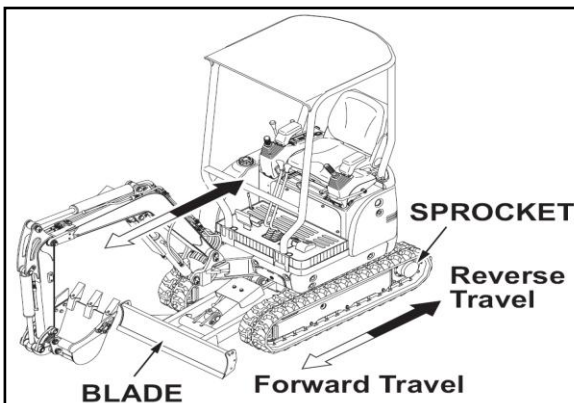

In the present specification, front, rear, left and right refer to the cabin when facing the front, and the drive wheels in the rear of the machine, when the traveling direction as seen from the cabin.

37. Confirm the direction of travel of the machine

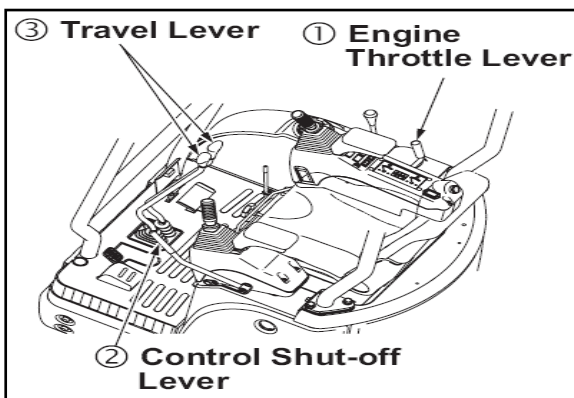

- (A) Before driving the machine to confirm the position of the lower part of the vehicle body and operation Personnel relations:

- If the motor running beneath the cabin, when forward brake pedal / lever, the machine will move backward.
- When the guide wheel is located under the cabin, to move forward the brake pedal/ lever, the machine will move forward.

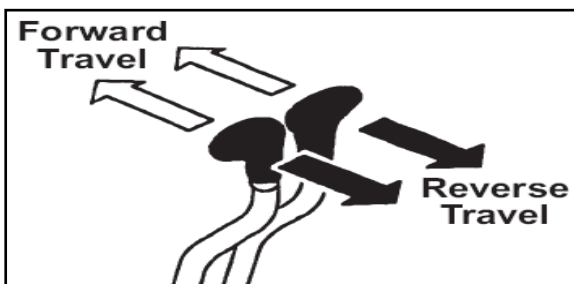

- (B) In the lower portion of the vehicle body inner side of the machine, paste with directions card. When the operator move forward the pedal / lever, the head pointing ways of the signs arrows is the actual direction of travel of the machine.



Walking pedal / lever mishandling can cause serious injury or death.

38. Walking safety rules

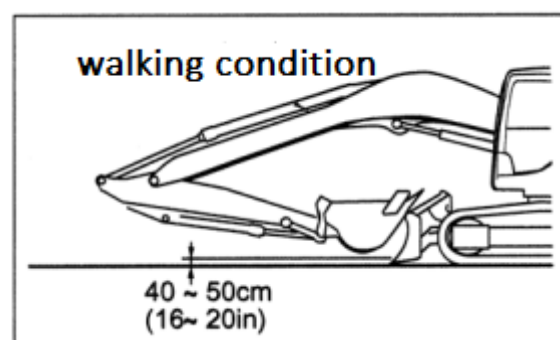

- (A) When using the machine, in order to prevent the stall due to an overload stall and to avoid the loss of working device, do not exceed the most of the machine allowable load or performance.
- (B) when walking on flat ground, to recover the working device and keep the ground height of 40-50cm (16-20in).
- (C) when walking on rough ground, walking to idle, and does

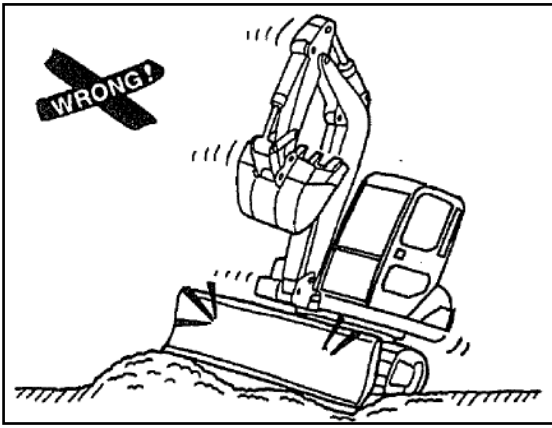

not to swerve, otherwise the machine will have to overturn. When the working device hit the ground, the machine out of balance, or would bad machines or structure.

- (D) When walking over rough terrain or on steep slopes, if the machine is installed downspeeding device, switch off (take off) the automatically downshift. If the automatic deceleration switch is turned on, the engine speed will mention high, walking speed suddenly accelerated.
- (E) As far as possible, avoid walking on obstacles, if the machine had to walk on the obstacles, to make the device close to the ground and low-speed walking. Do not cause the machine to violent tendencies walking on the side of the obstacle.

- (F) When walking or operation, must be with people, buildings, or other machines to maintain a safe distance to avoid contact with them.
- (G) When passing on from bridges or buildings, to first check whether the structural strength sufficient to support the weight of the machine.
- (H) When walking on the road, first of all the relevant authorities to check and follow their guidance.
- (I) When in the tunnel, bridge, wire or other highly limited operation to slow the operation, and to pay special attention not to let the working device to come into contact with any thing.

39. Driving machine safely

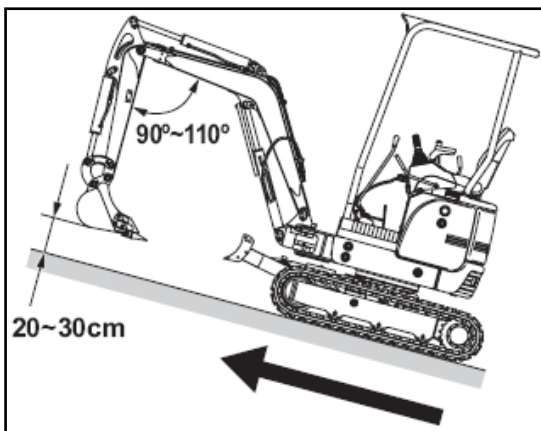

- (A) Before moving the machine, make sure the direction of travel and how to move step board or joystick.
- (B) Pressing the front portion of the pedal walking or forward implementation of walking poles, so that the machine move towards the guide wheel. (On the right track operation, With reference to the pedal, the operating lever to the part of the driving machine).
- (C) Walking in the slope may cause the machine to slip or tip over, resulting in serious injury or death. The slope walking, keep away from the ground to make the working device 20-30cm (8-12in). In case of emergency, you can quickly drops the work apparatus on the ground in order to help anchor the machine.
- (D) When walking uphill, transferred the the cabin facing the uphill direction.
- (E) When walking downhill, transferred the the cabin facing the downhill direction.
- (F) When walking, be sure to check the hardness of the ground in front of the machine.

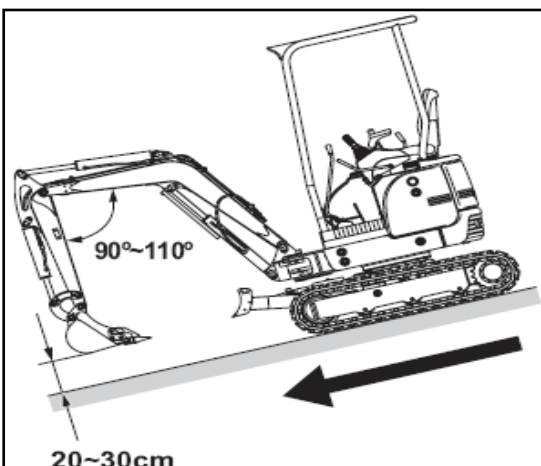

Safety — Safety operation of the machine

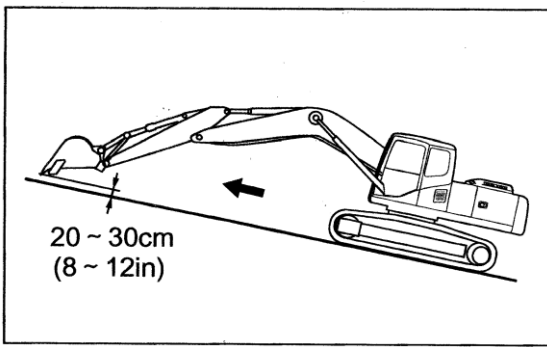

(G) when walking on steep slopes, Stretch the working device in front ,in order to improve balance, keep the distance from working device to the ground 20-30cm(8-12in) and low-speed traffic

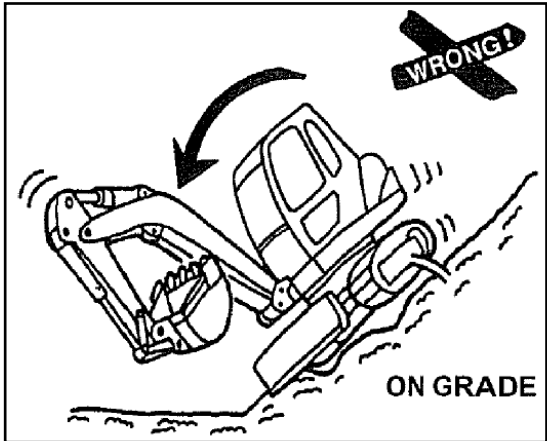

(H) when going downhill, reduce the engine speed, keep the travel lever maintained at a position close to the "median", and walking at a low speed.

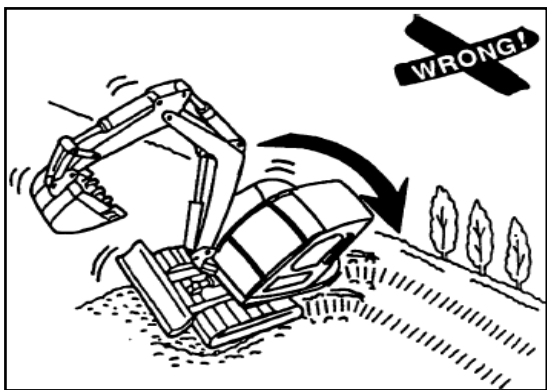

(I) Walking on the slopes straight up, straight down, because on the slopes steering or across the slope is very dangerous.

(J) Do not turn on slopes or across the slope. Be sure the next to a flat place to change the location of the machine, and then on the ramp slope.

(K) To the low-speed walking on the grass, leaves or wet steel,The machines also have a risk of slipping, even in the case of a small slope.

(L) If the engine is turn off when the machine is walking on the ramp, move the joystick to the "median",and then restart the engine.

40. To prevent the machine out of control causing injury



To prevent the machine from being out of control

- (A) when the machine should parked on the level of the ground as much as possible.
- (B) Do not park the machine on slopes.
- (C) The bucket and other tools are lowered to the ground.
- (D) The throttle control knob gear down to idling.

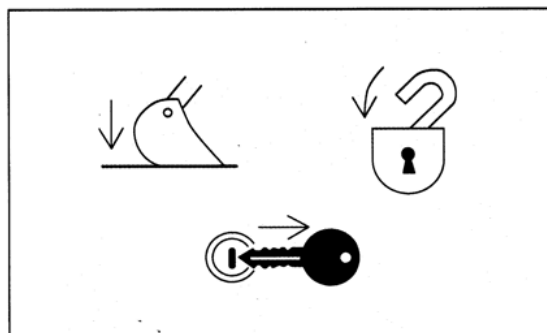

- (E) In the low-speed no-load operation of the engine 5 minutes, allowing the engine to cool.
- (F) Stop the engine, remove the key from the key switch.

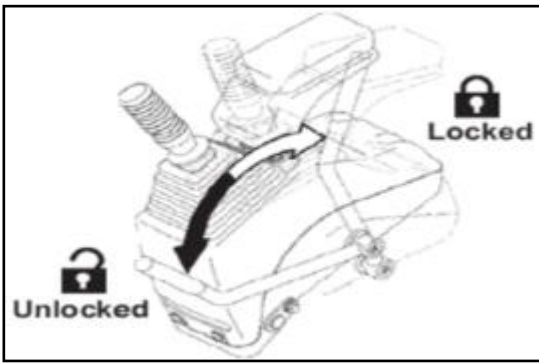

(G) Move the safety lever to the locked position shown on the photos.

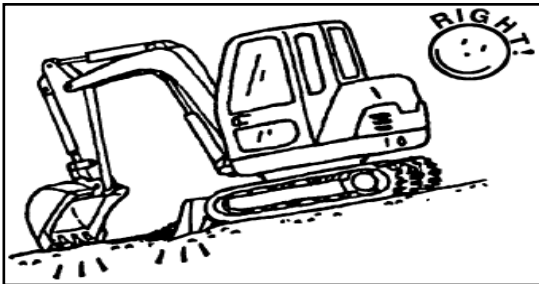

(H) If the machine must be parked on a slope, apply the stopper to withstand both sides of the tracks, and lowered the bucket, and insert the bucket teeth into the ground.

(I) positioning the machine, to prevent rolling.

(J) Parking the machine in the appropriate place far from other machines .

WARNING

If you attempt to climb or block mobile machines, it is possible the occurrence of serious injury or death.

41. Prevent reversing and rotary injuries

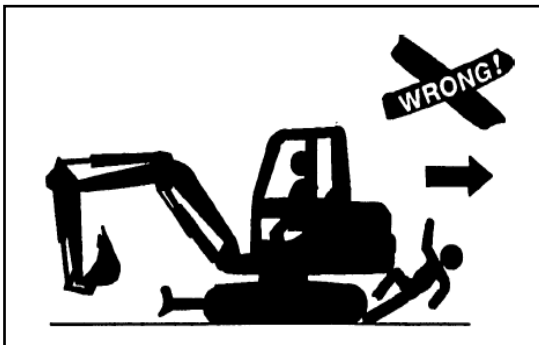

In order to prevent reverse rotation of an accident:

(A) Before reversing and rotary look around, recognized no one around the machine.

(B) Keep walking alarm device (option) in working condition.

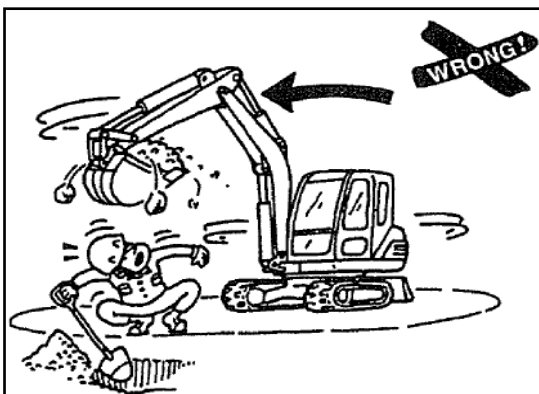

(C) Always be alert if anybody into the work area, before moving the machine ,warning others horn or other signal.

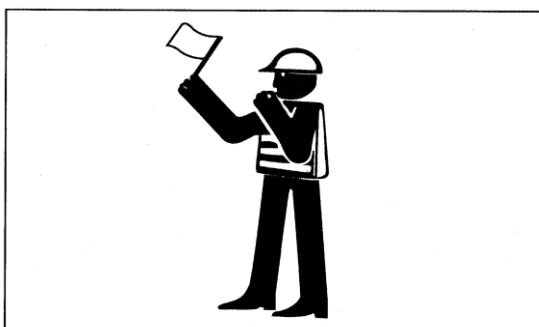

(D) In reverse, if your vision is blocked, to arrange the signalman Command, and to always keep the signalman in the field of vision.

(E) In the working condition of need signalman ,using the local regulations potential signal.

(F) Only if the signal and operators, who clearly understand the signal,and then move the machine.

Safety — Safety operation of the machine

- (G) Understand all the meaning of banner used in the work, signals and marked, and confirm who fat signal.
- (H) Remain intact windows, mirrors and lights is clean and undamaged.
- (I) Dust, rain, fog will reduce visibility. When the visibility is down, slow down, and the use of appropriate lighting.

WARNING

Reversing or turning on the machine, if someone in the vicinity of the machine, will be hit by a machine or overwhelming, resulting in serious injury or death.

42. Prevent access to the work area

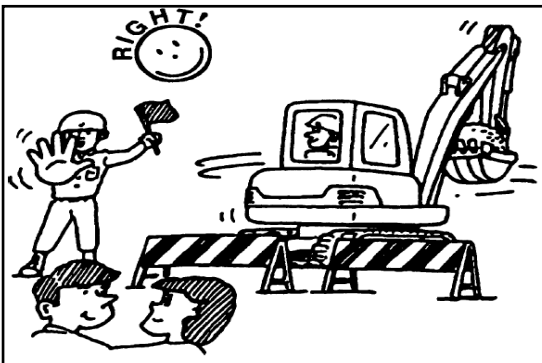

People are likely to be knocked down, even injured when doing rotating.

- (A) All people must be away from working area.
- (B) Before operating the machine, Set a good fence beside the rear of the bucket radius and back, in order to prevent personal injury or damage to the machine.

43. Do not put the bucket towards any person

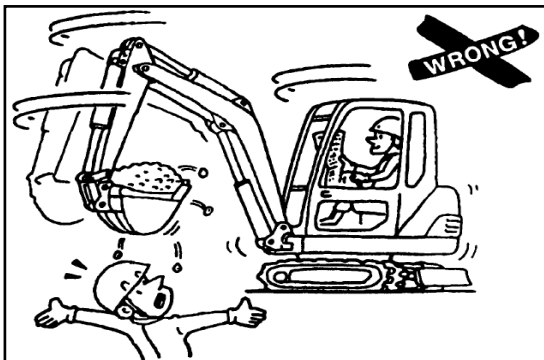

Bucket lifting, moving or rotating absolutely can not go through any person or the top of the truck cabin. If the fall of the material in the bucket or bucket collision may result in serious personal injury or damage to the machine.

44. Prevent emptied

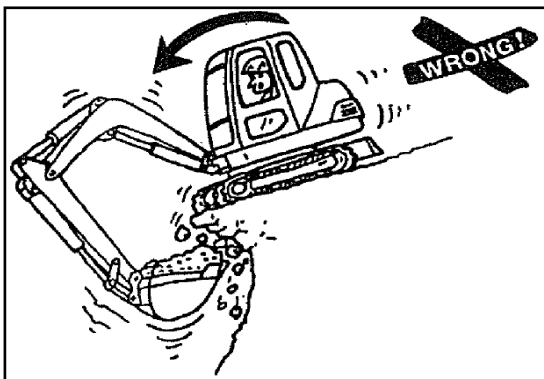

- (A) In order to ensure that to evacuate from Mizobe foundation collapsed, make sure the travel motor is in the back, the vehicle body is placed perpendicular to the gutter machine.
- (B) In the foundation began to collapse and the machine could not withdraw, do not panic, at this time, and lower the working device is generally fixed machine.
- (C) Excavation work to avoid the hollowing out of the soil of the bottom of the machine.

45. Prevent roll-over

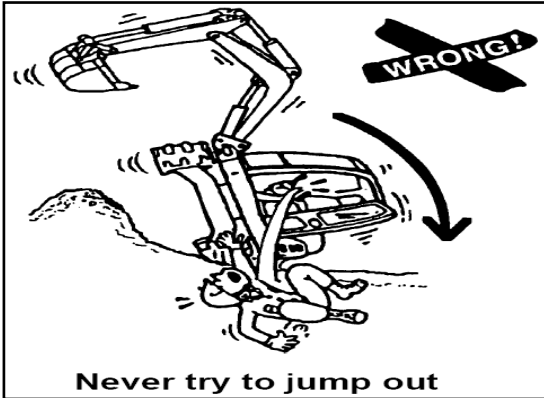

- (A) Do not try to jump out of the machine being dumped, otherwise it will cause serious or fatal crush.
- (B) Dumping speed of the machine faster than the speed you jump out, do not leave things to chance.
- (C) Be sure to wear seatbelts.
- (D) Operation on the slope, there is the risk of roll-over could result in serious injury or death.

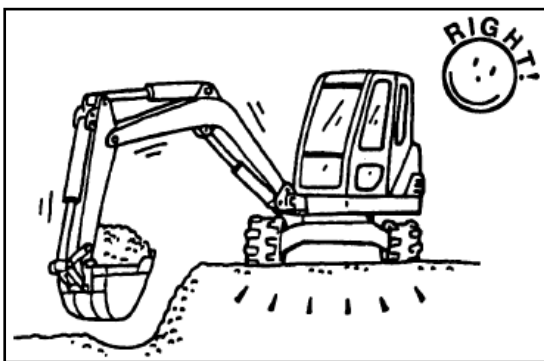

In order to prevent roll-over:

- (E) Operation of the slope with caution.
 - Smooth machine operation area.
 - The bucket lowered to the ground and close to the machine.
 - Slowing down the speed of operation, and prevent the roll-over or skidding.
 - Avoid changing the direction of the slope walking.
 - If the slope across the inevitable, never crossing slope greater than 15 degrees above the slope.
 - Slow down the rotation speed of rotation of the load, depending on the circumstances.
- (F) Operating in the frozen ground to be careful ,because the temperature rise will cause the ground to soften the ground unsteady gait.

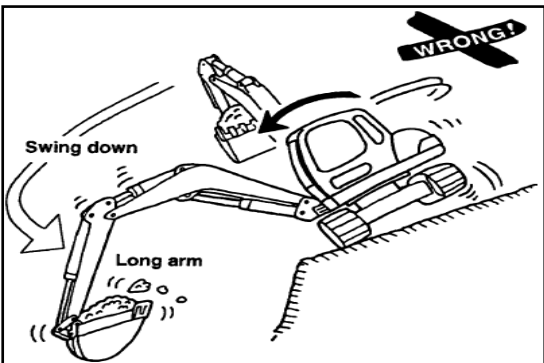

46. To prevent collapse



From the lower part of the excavation may cause the edge of collapse or landslide, resulting in serious injury or death.

47. Beware of underground facilities

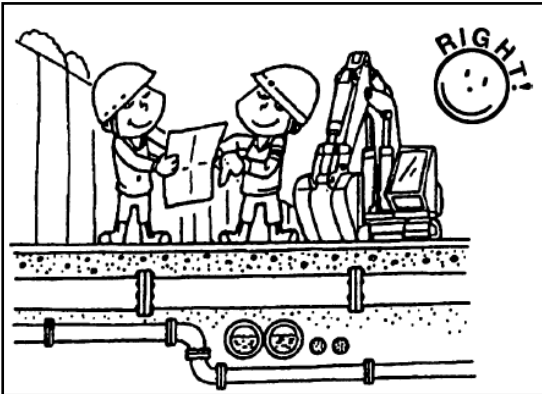

Underground cables or gas pipes are accidentally cut may cause an explosion, fire, leading to the occurrence of serious injury or death.

- (A) Prior to excavation, check cable, gas and water pipes position marked, or to confirm its position.
- (B) Keep certain distance with cables, gas pipes and water pipes.
- (C) If cut fiber-optic cable due to an accident, do not pay attention to the end of the cable. Otherwise, the eyes may cause severe damage.
- (D) If the Mining Hotline instructions in your area, please contact; or direct contact with the local utility company, so that they clear all underground cables, pipes.

48. Beware of overhead bridges and other facilities

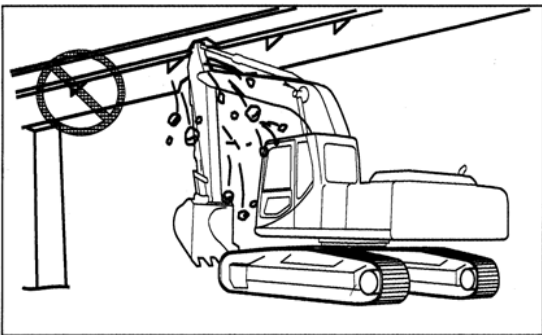

If the operating units of the machine or other parts of the elevated hit the bridge, machines and overhead material will be damaged and may cause injury, be sure to be careful.

49. To avoid the transmission line

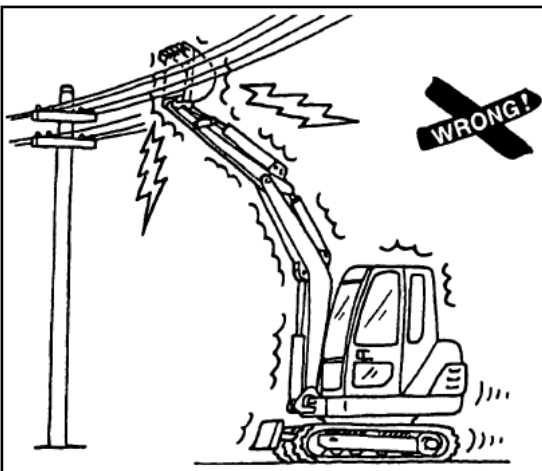

- (A) If the machine or device does not keep a safe distance with cable, may cause casualties and accidents.
- (B) when operating near the wire , avoid any part of the machine move to the place of the wire length over to 3 m plus 2 times the length of the line insulator distance.
- (C) Verify and comply with all applicabinle local laws and regulations.
- (D) Wetlands will increase the range of possible electric shock. Should be allowed other persons around away from the work area.

50. Secure parking machines

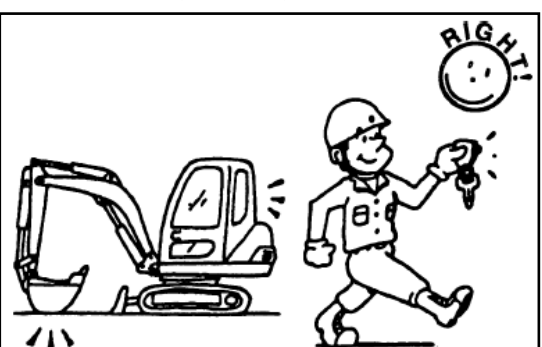

In order to prevent accidents:

- (A) The machine is parked on a level surface.
- (B) The bucket lowered to the ground.
- (C) The throttle control knob gear down to 1st gear.

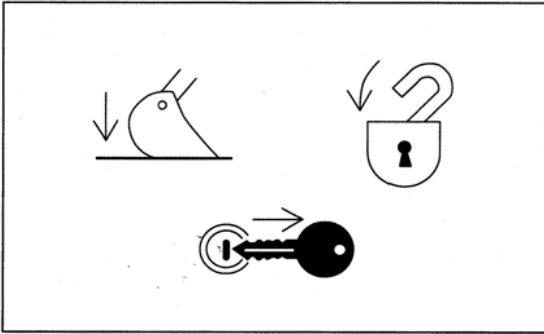

- (D) To the low-speed no-load operation of the engine 5 minutes.
- (E) Switch the key to OFF (off), stop the engine. After the engine is stopped, turn the key switch to “on” position, put safety lever at UNLOCK position, shaking each joystick to escape residual pressure in the hydraulic circuit and pneumatic circuit.
- (F) Remove the key from the key switch.

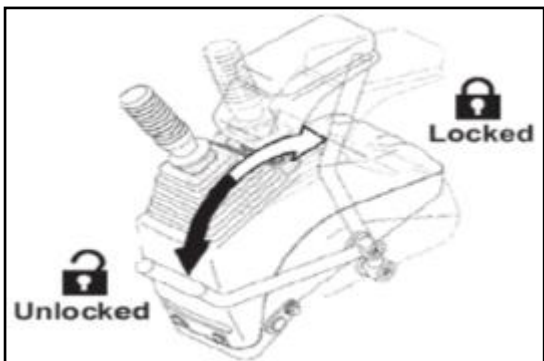

- (G) The safety lever pulled at Lock (locked) position.
- (H) Closed windows, skylights and cabin door.
- (I) Lock all access doors and box room

51. Handling fuel - to prevent fires



- (A) Handling fuel safely, because it is highly flammable. If fuel is ignited, it will explode and (or) fire, resulting in personal injury or death.
- (B) When filling fuel oil, make sure no smoking or fire around.
- (C) Before refueling, be sure to stop the engine.
- (D) Add fuel outdoors.
- (E) All of the fuel and most of the grease agents and some coolant are all flammable.



- (F) Flammable liquids stored in a place away from the risk of fire.
- (G) Do not incinerate or puncture the pressure vessel.
- (H) Do not store oily rags, they can be lit fire spontaneously to burn

52. Safety transport

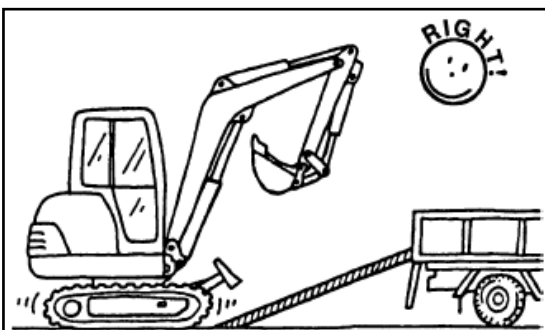

- (A) In the truck or trailer plate loading and unloading machine, the machine will be overturn.
 - When moving machine from road transport, be sure to comply with local regulations.
 - Provide for the transportation of the machine to the

truck or trailer.

(B) Loading and unloading the machine, please note the following:

- Select a firm level ground.
- Be sure to use the loading dock or slope.
- When loading or unloading machinery, there must be a signalman.
- Loading and unloading machine, you must turn off the auto-idle switch to avoid the operating lever accidental operation and cause a sudden increase in speed.

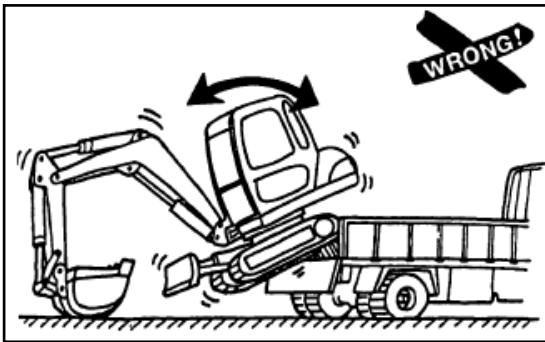

- Switch to select slow walking. Fast walking speed will automatically increase.
- Shift on an incline is extremely dangerous, and should be avoided in the lower slope steering. If you need to turn the machine, you should be directed back to the ground or car plate, then onto the slope correction direction.
- In addition to the travel lever onto or driving under the slope, do not operate any other joystick.
- The top of the slope and flat relative to the Survey Office was convex, care should be taken to passing.
- Rotary car to prevent injuries may cause the machine to tip over.

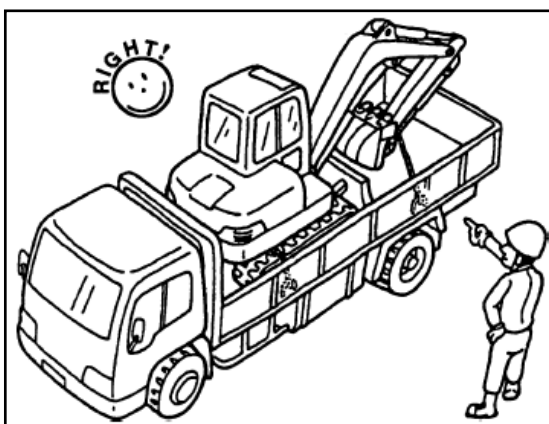

- Keep the arm pulling and slowly turn the car in order to get the best stability.
- Chain or rope to hold the machine frame. For more information, see the "Transport" chapter.

53. Forbid to lift heavy things



Hanging objects falling around may be hit by falling objects or suppress, resulting in serious injury or death. In order to prevent accidents, in any case, prohibition lifting.

1-3. Safety and maintenance instructions

1-3-1. Carry out Safety and Maintenance

1. In order to prevent accidents:

- (A) Understand the maintenance procedures before operating.
- (B) Keep the work area clean and dry.
- (C) Do not spray or steam in the cabin.
- (D) When the machine is moving, not the machine lubrication or maintenance.
- (E) To avoid the hands, feet and clothes touch with rotating parts.

2. Before maintenance of machine

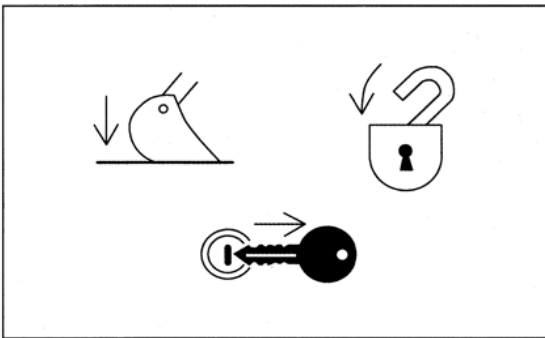
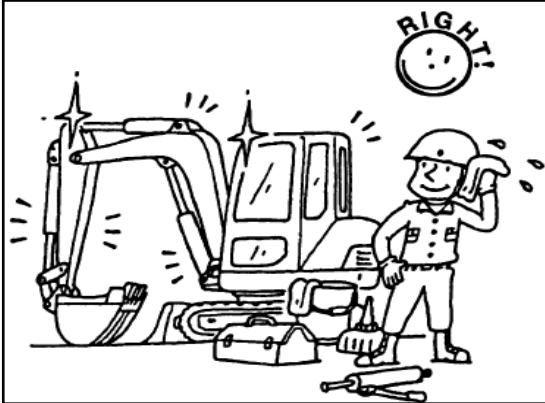

- (A) Park the machine on level ground.
- (B) The bucket is lowered to the ground.
- (C) The throttle control knob gear down to 1st gear.
- (D) low-speed no-load run the engine for 5 minutes.
- (E) The key switch to the OFF (OFF) position, stop the engine.
- (F) Move around a lever to release the pressure in the hydraulic system.
- (G) Remove the key from the key switch.
- (H) In the control rod to hang the "Do Not Operate" sign.
- (I) Pull the pilot control lever to the locked position.
- (J) Cooling the engine.
- (K) If maintenance must be in the state of the engine is running, please do not let anyone on the machine.
- (L) If maintenance must lift the machine, should be maintained within 90-110 ° angle between the boom and stick. Firmly supporting any part of the lifted on the machine.
- (M) Non-operating in passive arm lift machine.
- (N) Regular inspection of certain parts ,do repair or replacement if needed. Refer to the manual "maintenance" chapter of the content.
- (O) Keep all parts in good working condition and properly installed.
- (P) Timely processing of damaged parts, replacement of worn or broken parts. Clear any accumulation of grease,



oil or debris.

- (Q) Before adjust the electrical system or welding on the machine , be sure to disengage the battery (-) ground cabinle.
- (A) Unexpected machine movement can cause serious injury.
- (B) Before doing any work on the machine, hang the "Do Not Operate" sign on the control rod.

4. Keep work area clean and tidy

- (A) Do not throw the hammer or other tools fall on the work area.Wipe slipping all grease, oil or other substances likely to cause, to keep the work area clean and tidy, in order to safely operate.
- (B) If you can not keep the work area clean and tidy, there will be tripped, the risk of slip or fall and cause injury.
- (C) Using of water for cleaning the the top window manufacturing with plexiglass (polycarbonate), do not use any alkaline solvent. The spent as benzene, toluene, methanol, or other alkaline solvents, there will be a chemical reaction, such as dissolving or decomposing glass, polycarbonate and aging.

5. Engine is running, you need two people to carry out maintenance

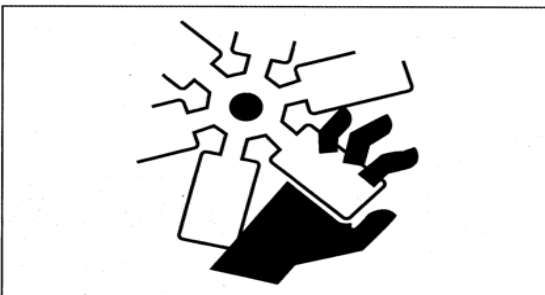

To prevent injury, when the engine is running, do not carry out maintenance.If you must operate the engine running, they have in the case of at least two people to operate in accordance with the following provisions:

- (A) One person must be sitting in the operating chair and ready to turn off the engine. All personnel must keep in touch with each other.
- (B) Pull the safety lock lever to the locked position.
- (C) Operation close to the fan, the fan belt or other rotating parts,it has the dangerous of stuck by parts, so pay special attention.
- (D) Do not touch any control lever;if must operate a lever, send a signal to othe persons,warn them to move quickly to a safe place.
- (E) Do not put tools or other objects to fall into or insert the fan or the fan belt, otherwise it would be parts breakage or flying out.

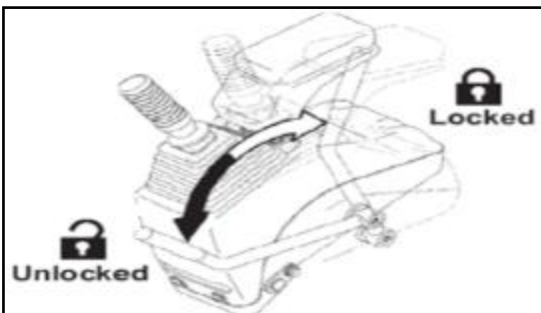

6. The right tools

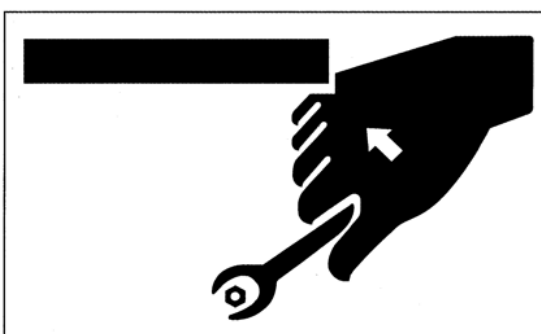

- (A) Only use the right tools and the correct use of tools.
- (B) If use the tool of damaged, inferior, defective, temporary or improper can cause serious injury.

7. Correct prop machine



- (A) Never maintenance the machine in the absence of support machine .
- (B) Before maintenance machine, the working device should be down to the ground.
- (C) If you must lift the machine or device to carry out maintenance, support the prison machine or device. Do not use slag bricks, hollow tire or shelf to support the machine, they will collapse under a continuous load. Do not work in a machine with a single jack support.

8. Accumulator



The accumulator red high-pressure nitrogen. When operating the accumulator, carelessness may cause explosion ,resulting in serious injury or damage. Therefore, we must observe the following precautions:

- (A) Do not disassemble the accumulator.
- (B) Do not let the accumulator near fire or to storm drain in flames.
- (C) Do not punch holes, welding or torchin on the accumulator.
- (D) Do not bump or rolling accumulator or accumulator subjected to any impact.

(E) When the disposal of the accumulator, you must be deflated. Please contact with CARTER dealer to carry out such operations.

Notice: mini excavator has no accumulator.

9. Welding operations

Must carry out the welding operation by qualified welders, and equipped with the proper equipment. When electric shock. Therefore, do not allow unqualified personnel for

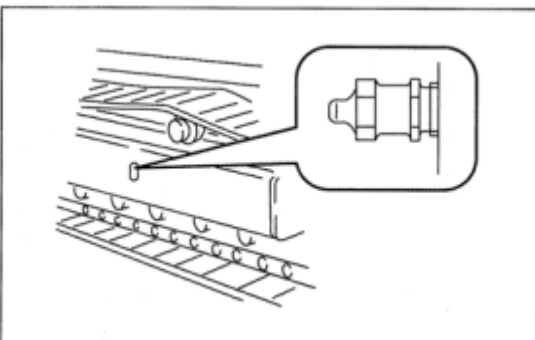

remove the negative (-) terminal of the battery to prevent static

High-pressure greasing, first of all pay attention to safety

- (A) Grease is pressed under high pressure into the track tension adjustment system.
- (B) When the adjustment, if there is no compliance with maintenance procedures, grease drain plug will fly out and cause serious injury or damage.
- (C) when to relax the track tension and release the grease drain plug, loosen the drain plug not to exceed one circle, and slowly Loosen the grease drain plug.

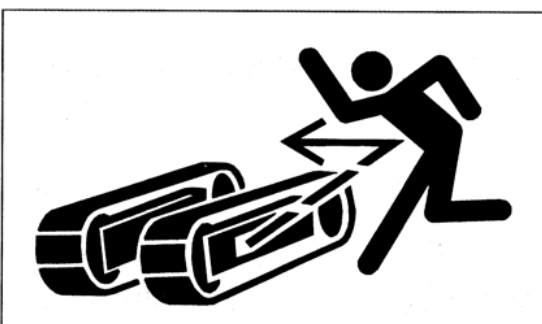

- (D) Do not make of the face, hands, feet, or body near the grease drain plug.

12. Do not remove the buffer spring

Buffer spring assembly used to mitigate the impact of the tension pulley, which includes a high-pressure spring, so if demolished with error, spring will fly out, resulting in serious injury or even death, so do not remove the spring.

13. Compressed air

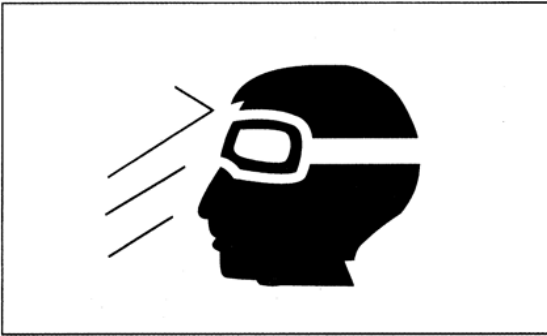

- (A) When cleaning with compressed air, flying particles may cause personal injury.
- (B) When using compressed air to clean the filter or heat sink, to wear goggles, dust masks, gloves and other protective equipment.

14. Regular replacement of safety-critical parts

- (A) In order to long-term safe operation of the machine, it is necessary to periodically refueling and maintenance. To further enhance security, hoses, seat belts and other safety-related parts must be replaced periodically.
- (B) Exceeds a predetermined time, the parts of the material will naturally change. Repeated use can cause deterioration, wear and damage, the result will malfunction and cause serious injury or damage. When in operation, according to external inspection or touch difficult to judge how long these parts can be used, therefore must be replaced regularly.
- (C) If you find any defects in safety-critical parts, has not yet reached a specified time, you have to replace or repair.

15. Regular replacement of rubber hose

- (A) Due to aging, excessive wear, rubber hose containing flammable liquids may break under pressure. The aging and wear of the rubber hose, check alone is difficult to judge the extent of its bad. And should therefore periodically replace the rubber hose.
- (B) From time to time to replace the rubber hose may result in fire, liquid injected into the skin or the device hit around the personnel accident, causing severe burns, gangrene, or other injury.

16. Regular maintenance of air-conditioning systems



- (A) Refrigerant spilled on the skin can cause frostbite, never make the refrigerant touch with the skin.
- (B) The maintenance of the air conditioning system, with reference to the description of the refrigerant container, correct use the refrigerant. Refrigerant is R134a, can not be used with other refrigerant, otherwise it will cause damage to the air conditioning system.
- (C) The use of recovery and recycling system to prevent refrigerant emissions into the atmosphere.
- (D) Keep away from the sources of ignition when maintenance the air-conditioning system .

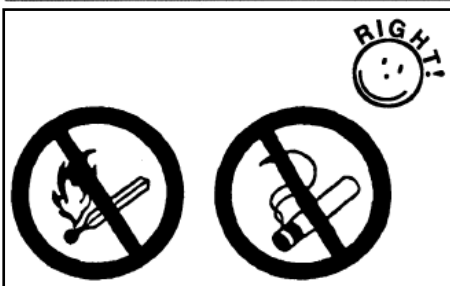

Notice: mini excavator has no air-conditioner.

 **WARNING**

R134a refrigerant is non-toxic gas at room temperature, but it will become highly toxic gas when exposed to an ignition source.

1-4. Warning signs and icons

1-4-1. Product nameplate

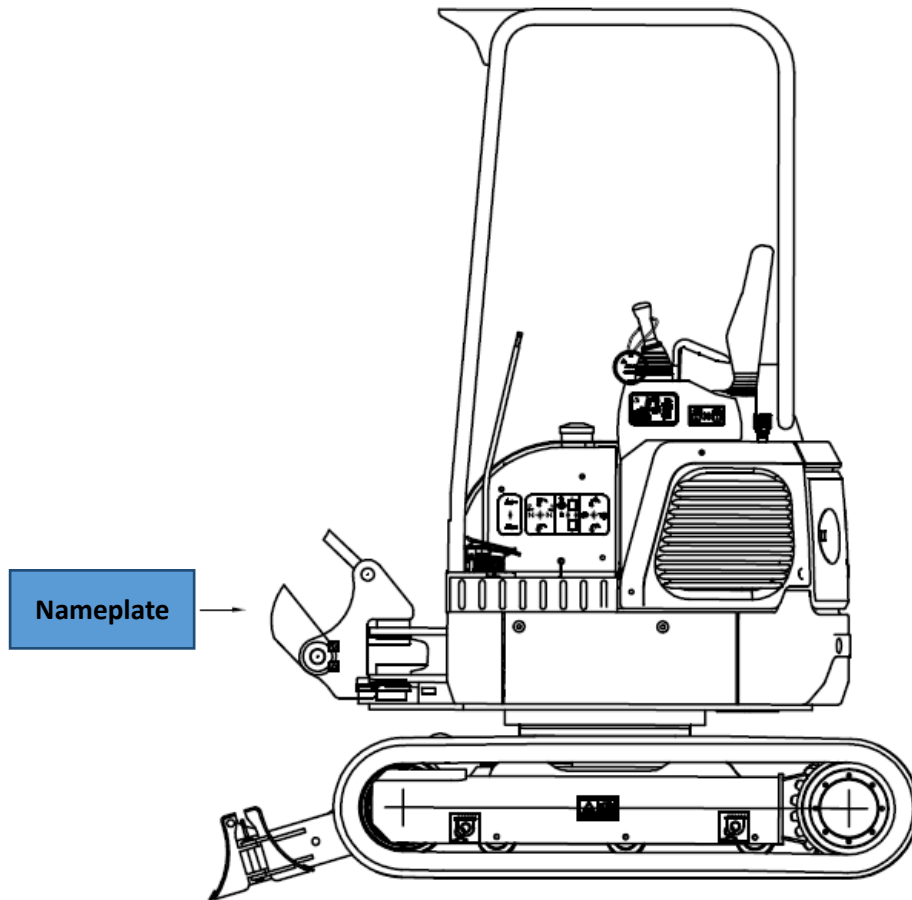

Product nameplate riveted on the front of the left platform.

HYDRAULIC EXCAVATOR		MANUFACTURE YEAR	<input type="text"/>
MODEL	<input type="text"/>	BUCKET CAPACITY	<input type="text"/> m ³
ENGINE POWER	<input type="text"/> kW	WEIGHT	<input type="text"/> kg
PRODUCT SERIAL NUMBER		<input type="text"/>	
USA CARTER HEAVY INDUSTRY GROUP, INC.			
CHICAGO, STATE OF ILLINOIS, USA Support Scandinavia: 0045-8699 7314			

Nameplate Sample!

1-4-2. The position of the safety labels

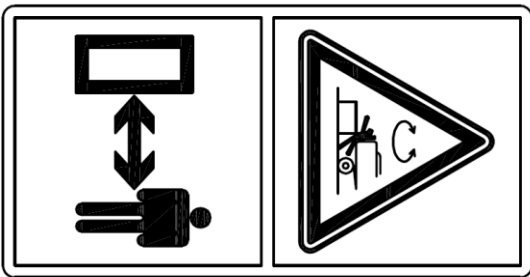
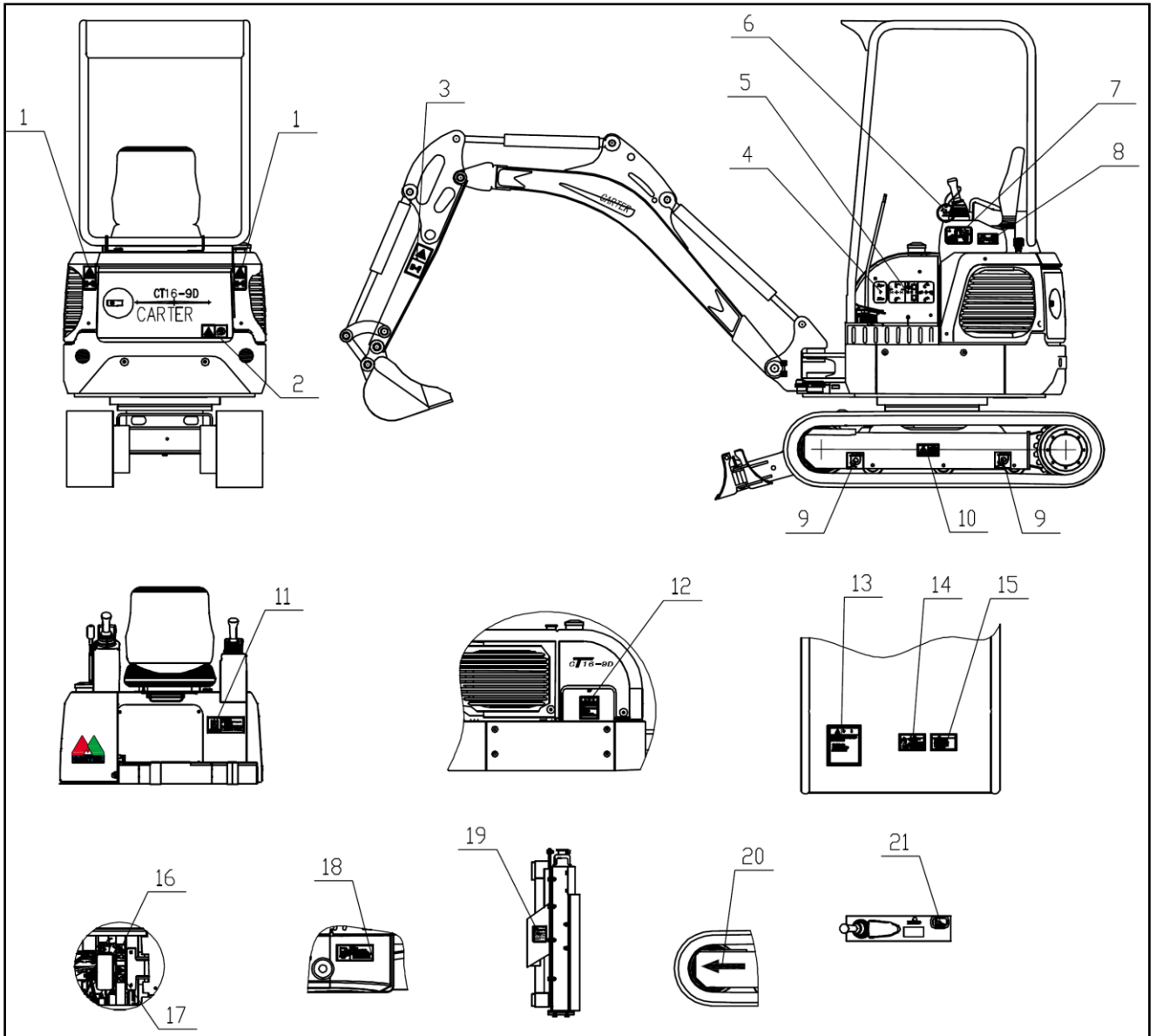

1. Warning! Excavator Working Range

- Don't stay at working area!
- Otherwise, dangious to be rolled!

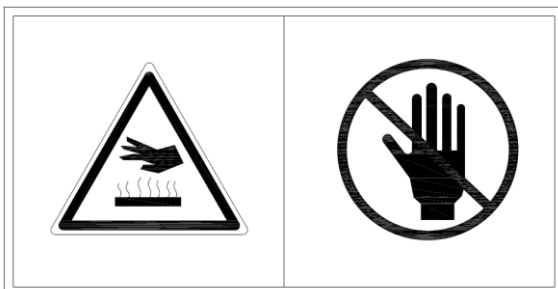

2. Warning Signs of Surface High Temperature

- Forbid to touch by hand!

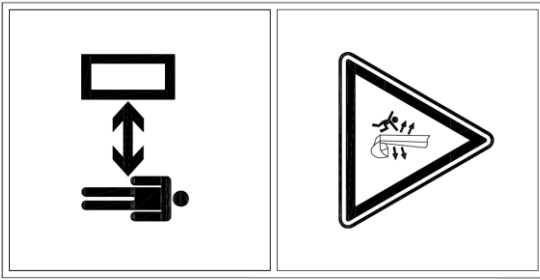

3. Warning! Excavator Working Range

- Keep space with excavator's working area!
- Otherwise, dangious to be injured!

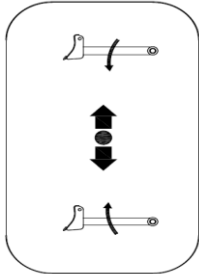

4. Blade Operation Signs

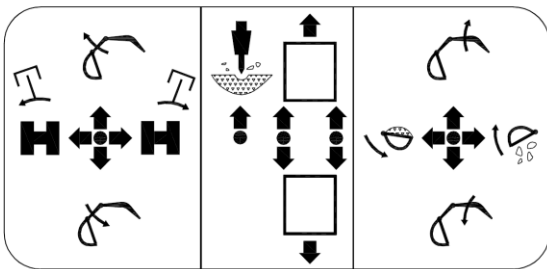

5. Machine Operation Options



6. Warning Signs when checking and maintaining

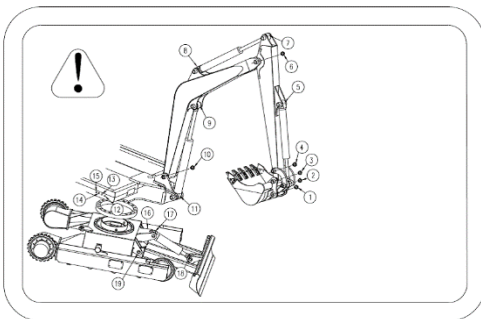

7. Machine Lubricating and Maintenaining Signs

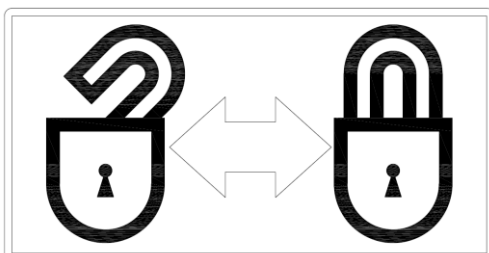

8. Saftey Control Level "Lock, Open" Signs

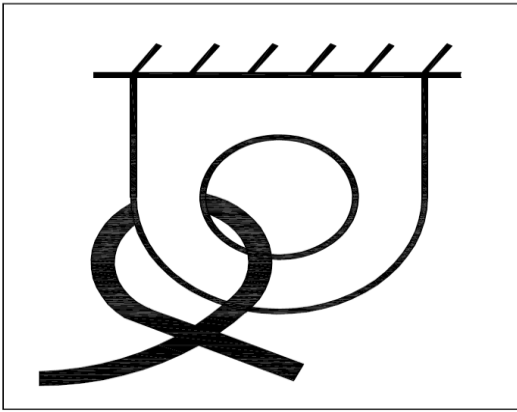

9. Hook Point Signs when hoisting machine

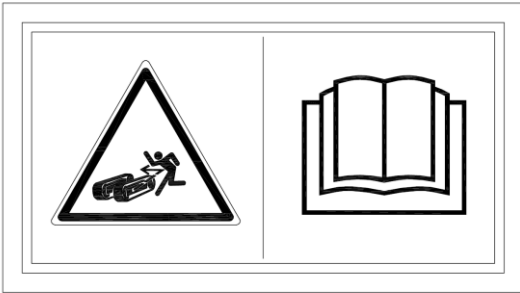

10. Prevent parts flying out

Before operation, please read Instructions carefully.

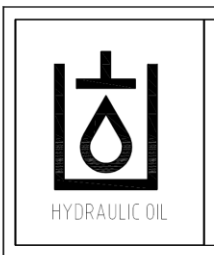

11. Hydraulic Oil Tank Signs

- Warning user the specification of hydraulic oil, and the time to change hydraulic oil, Oil suction filter and return oil filter.

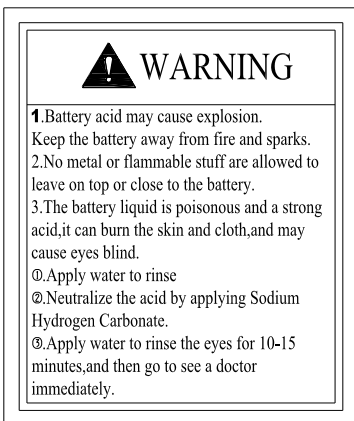

12. Battery maintenance and use signs.

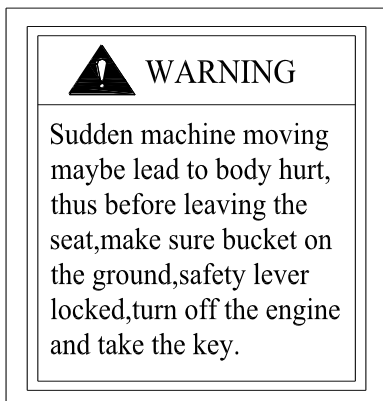

13. Leaving Driver Seat Signs

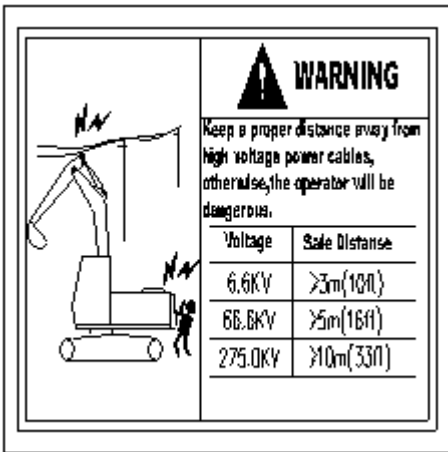

14. High Voltage Line Warning Signs

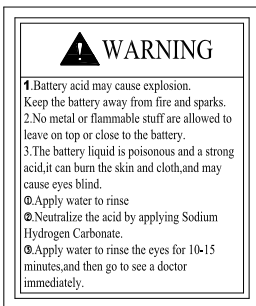
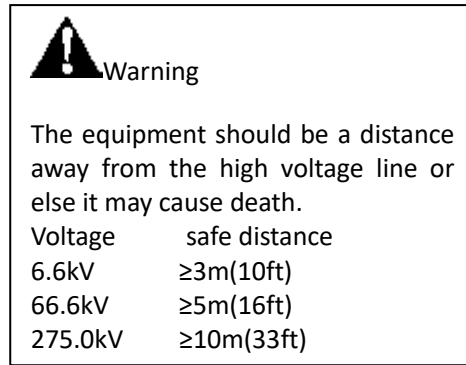

15. Operation Warning Signs

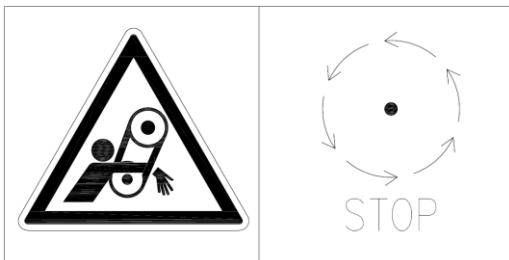

16. Warning! Be Care of Belt!

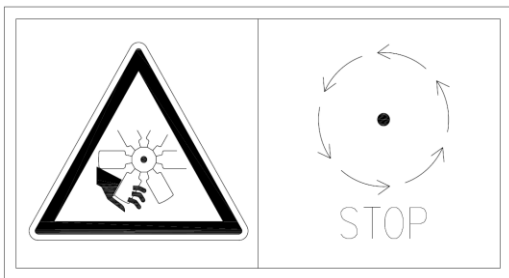

17. Warning! Be Care of the Rotating Objects!

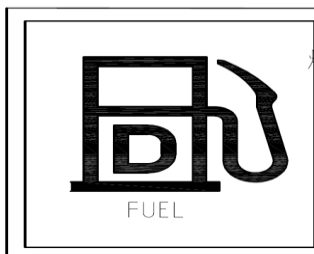

18. Diesel Tank Signs.

- Warning user to fill different specification's diesel in different temperature and the time to change filter and clean tank.

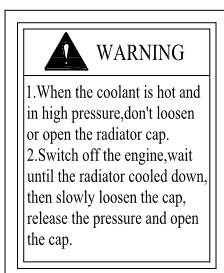

19. Warning, Prevent high temperature to burn!

20. Excavator Forward Direction

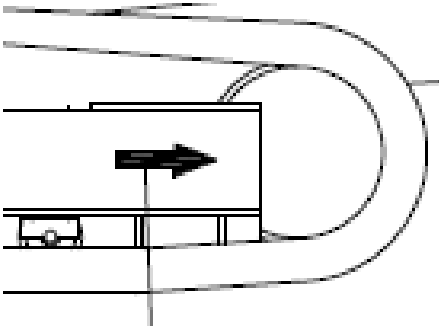

21. Accelerator Signs

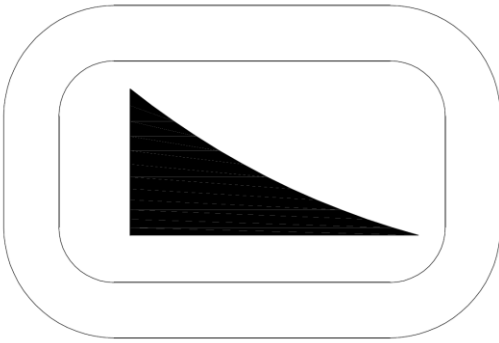

Chapter 2-Components, Instrument and Controller

2-1. Name of components

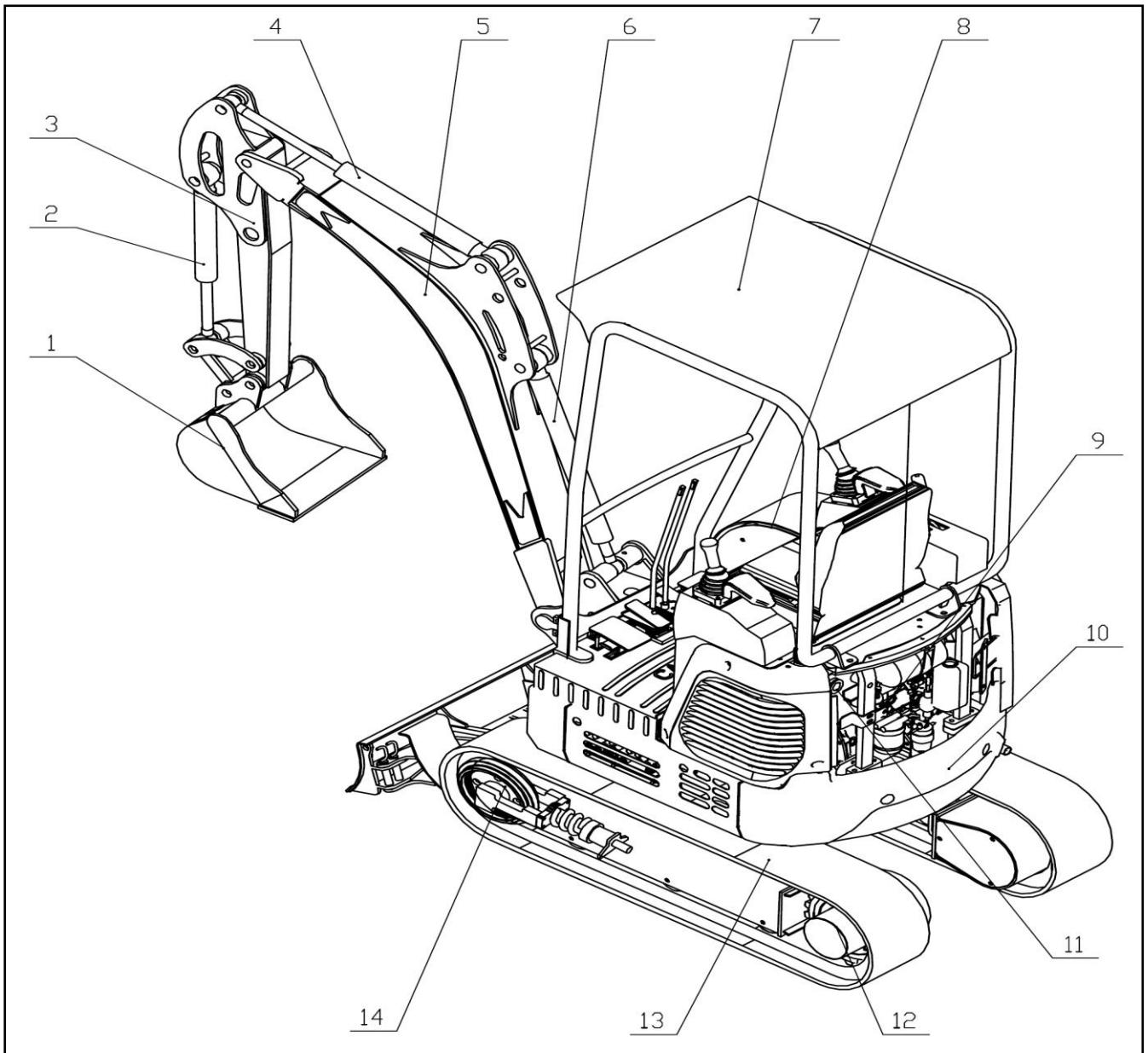

NO.	Name	NO.	Name
1	Bucket	8	Fuel Oil Tank
2	Bucket Cylinder	9	Engine
3	Arm	10	Counterweight
4	Arm Cylinder	11	Hydraulic Oil Tank
5	Boom	12	Traveling Device
6	Boom Cylinder	13	Track
7	Canopy	14	Tightening device

2-2. Cabin

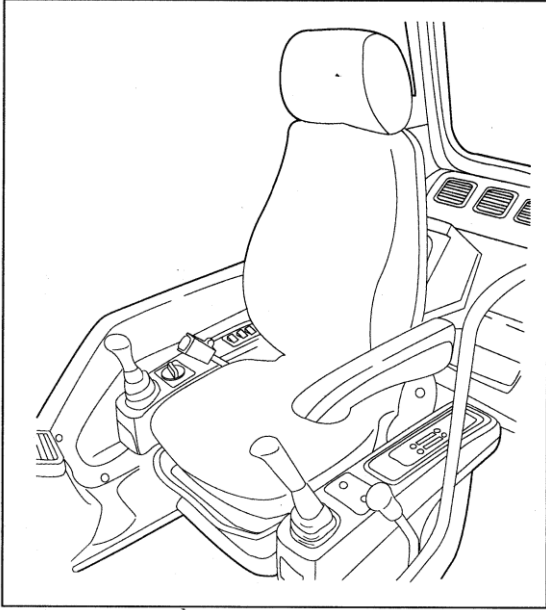

- (A) The inside of cabin is designed according to the ergonomically, easy to adjust, the operating force of joysticks and foot pedals is light, each manipulation buttons are within the scope of the driver's reach.
- (B) Cabin dormer can be opened, the front window can be turned up to the top, you can see the crawler and the ground nearby by the below window. Back windows provide a good vision of rear and left side, there is a broad perspective in the interior of the cabin.
- (C) The interior of the cabin is equipped with heating and air conditioning, stereo, to improve the working environment.
- (D) With multi-faceted adjustable seats, front-rear position and tilting angle can be adjusted.. Equipped with mechanical suspension device under the seat to minimize the vibration of the machine, ensure to comfortable of operating.

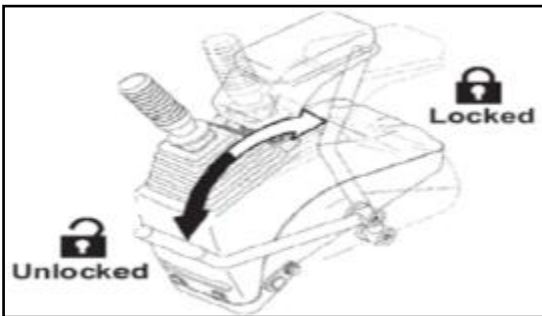

- (E) Equipped with a hydraulic actuation lever (safety lever) beside seat, when the operating lever is pulled back to the "LOCK" position, all of the hydraulic actuating mechanism can not be operated, so that it does not cause accidental manipulation when the driver up and down the cabin.

2-2-1. The Internal Parts of the Cabin

No.	Name
1	Auxiliary Pedal
2	Left Traveling Operating Lever
3	Right Traveling Operating Lever
4	Boom Deflection Pedal
5	Right Joystick
6	Electric Lock
7	Starting Switch
8	Throttle Operating Lever
9	Display Screen
10	Blade Joystick
11	Left Joystick
12	Pilot Control Switch (Safety Control Lever)

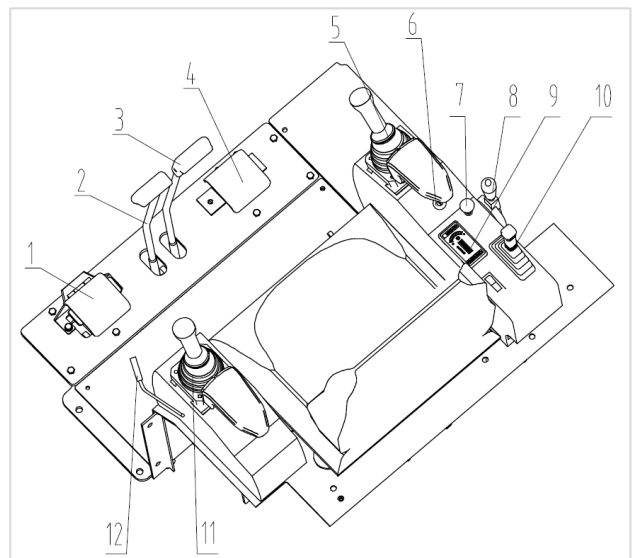

(1) Left Control Box Introduction:

Safety Control Lever (marked with red oval in the following picture)

Components, Instrument and Controller—Cabin



Safety lever controls the whole machine's move (not including the functions and performance of blade, undercarriage extension, swing boom and hammer). When the lever is put up, the whole machine is in safety and has no movements; when the lever is down, the machine is in working status, and all the functions can be performed.



There is red button on the joystick, this button is to control chassis extension. The extension is carried out by the coordination of the button and blade joystick, by pressing the button and performing blade joystick.

(2) Right Control Box Introduction:

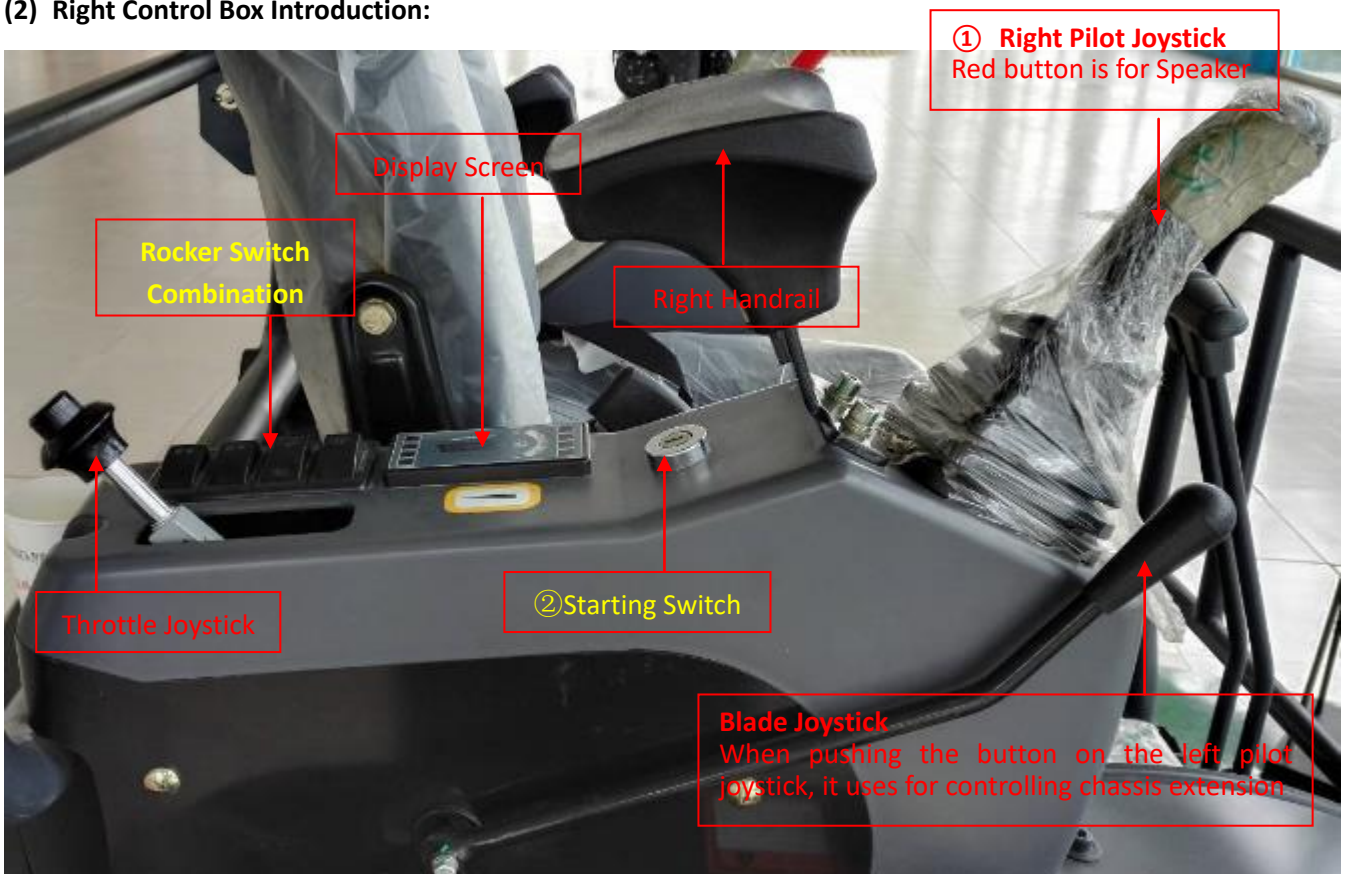

Rocker Switch Combination for canopy type Picture:



- ① The button on the right pilot joystick is for alarm by pressing it or releasing.
- ② Starting switch is to control the power off and on of the machine. It has three positions (For Perkins engine, the preheating function cannot be used, because Perkins engine has special requirement for preheating function). OFF position to shut off the power positive electrode, ON is to turn on the power positive electrode, START is to start the excavator.
- ③ Rocker switch for lamp is to control the lamp on and off by pressing it down and up.
- ④ Rocker switch for high and low walking speed. The switch has two models for walking speed. Pressing rabbit symbol means high speed, turtle means low speed.
- ⑤ Rocker switch for cleaning and water-spraying front window. The switch is inching type switch, press it, it will spray water; release it and it will stop spraying water.
- ⑥ Rain wiper switch button. It is to control the wiper motor by pressing it up and down.

Remarks:

The items ⑤ and ⑥ are special for excavator with cab; Excavator with canopy has no such functions, just standby switch.

Rocker Switch Combination for cabin type Picture:



Power Switch:



This switch is the negative control switch of the machine's power, when the switch is on "L", the whole machine's power turn on, when switch is on "O", power is cut off.

2-2-2. Display Screen



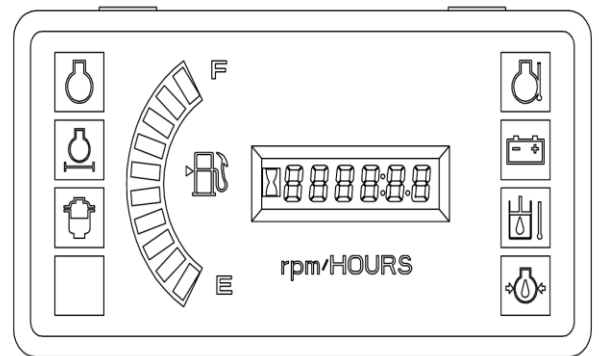
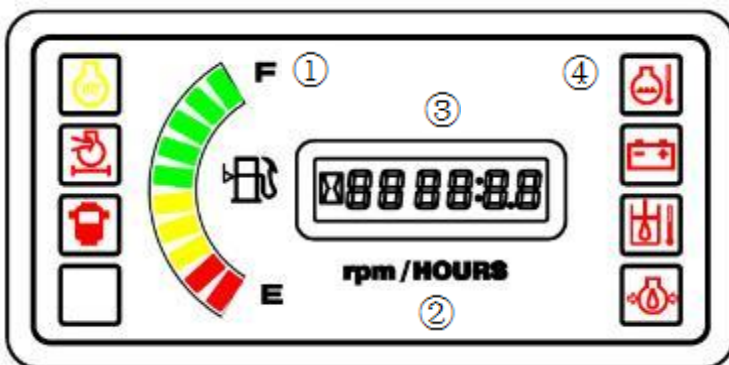





Display Screen Introduction:



- ① Fuel Oil Gauge:
E-F, displayed with 10 section LED color; When the oil is lower than total amount 1/5, it will be alarm display area, displaying red LED.
- ② Engine Tachometer: LCD Digital Display.
Speed signal will be obtained from the flywheel of engine through sensor.
Engine Speed=Pulse count detected within 1 second *60/teeth number.
- ③ LCD Screen Display:

LCD Screen displays hourmeter and revolution speed. LCD screen only displays hourmeter, when the revolution speed is no changes; LCD screen displays revolution speed when the revolution speed changes.

④ Alarm Display Function:

NO.	Function	Alarm Mode	Indicator Light Icon
1	Charging Signal	Indicator Light	
		Indicator+ Buzzer	
2	Oil-Water Separator	Indicator+ Buzzer	
3	Preheat	Indicator Light	
4	Fuel Gauge	Red color twinkle	
5	Engine Oil Pressure	Indicator Light	
		Indicator+ Buzzer	
6	Air Filter	Indicator+ Buzzer	
7	Water Temperature	Indicator+ Buzzer	
8	Hydraulic Oil Temperature	Indicator+ Buzzer	

2-2-3. Fuel Gauge

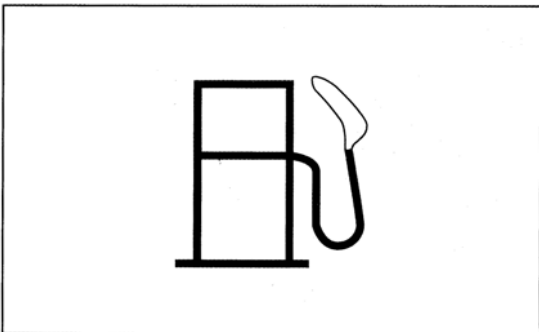

Refuel into the tank when the oil reaches to the red zone.

2-2-4. Work light position

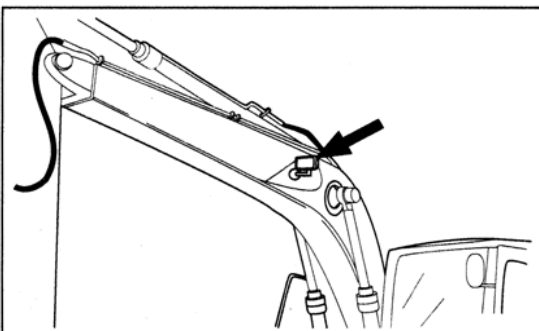

Working light on arm-1pc.

2-2-5. Start Switch

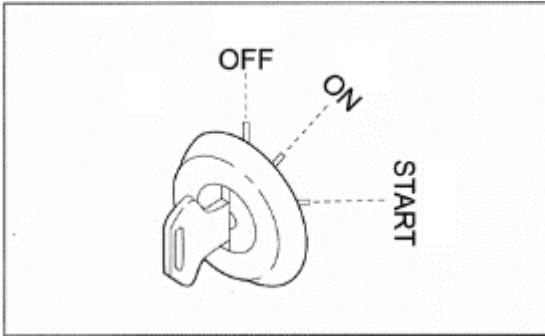

OFF-----Power Off
ON-----Power On
START-----Engine Start

!WARNING

To avoid damage to starter, start key should be less than 15sec on the start position.

2-2-6. Throttle control lever

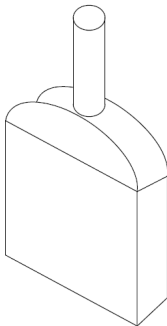

Pressing the button on the the contrl lever, push the control lever forward to increase throttle, push the control lever back to reduce throttle.

2-2-7. Horn switch

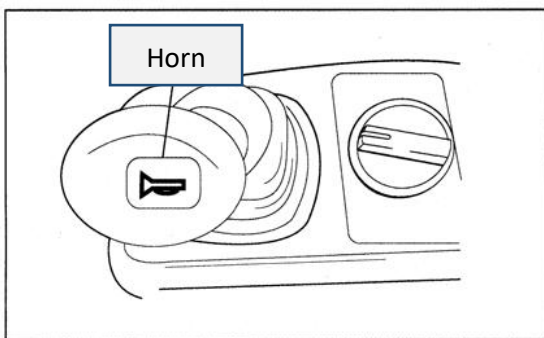

Horn switch is on the top of righ joystick, as long as pressing the button, the the horn will be resound.

2-2-8. Pilot control switch lever(Safety operation lever)

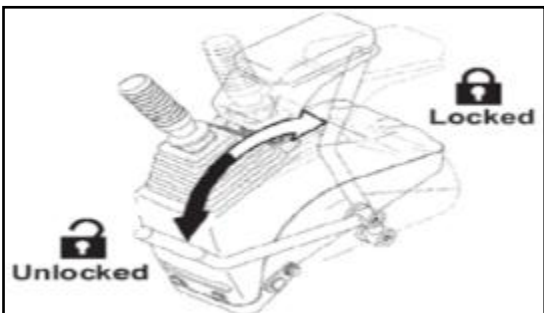

Pilot control switch lever is to prevent mistake when the operator up and down the machine

!WARNING

- If the pilot control switch lever is not pulled fully to the locked position, the pilot control will not be cut off.
- Away from the operator's seat, the pilot control switch lever should be pulled to the locked position, and then turn off the engine. When transporting the machine, or after the completion of day's work, also pull the pilot control switch lever to the locked position.
- Before starting the engine, make sure the pilot control switch lever in the locked position, otherwise the engine can not be started.

2-2-9. Cup bracket

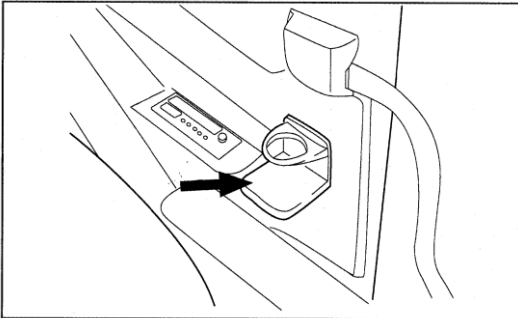

For driver to drink water.

2-2-10. Cabin heating device

Cabin heating device is to inject the cooling water of the engine into the cabin, for distributing heat to the cabin via the air-conditioning fan, to achieve the purpose of heating.

!CAUTION

Notice: just turning on the power switch of heater

!CAUTION

- Because the heating system is communicating with water tank, when the ambient temperature is lower than -35°C , if you don't use machine for long time, water tank should keep empty to prevent heater's pipe cracking.

2-2-11. Cabin door release lever

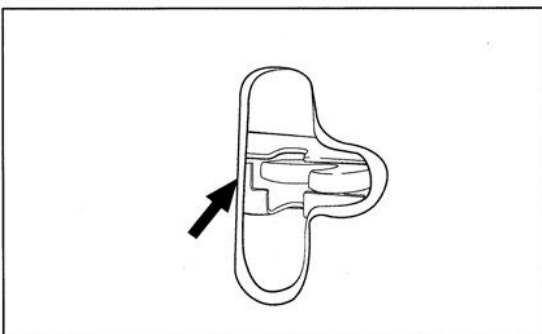

!CAUTION

When the cabin door is in the status of opening, the cabin door should be fully open until it is locked by the latch on the sidewall.



When opening, first depressed the driver door release lever in the left side of the cabin, open the latch, and then close the cabin door.

2-2-12. Opening the front upper window

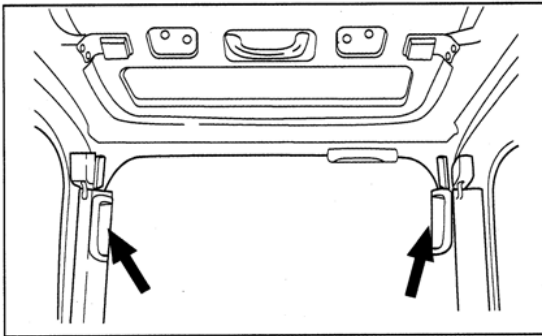

- (A) Press the lock to open the door and window.
- (B) Sliding the front window backward and the Rear Window forward.

CAUTION

Don't operate rain wiper when open front window and after opening

2-2-13. Close the front upper window

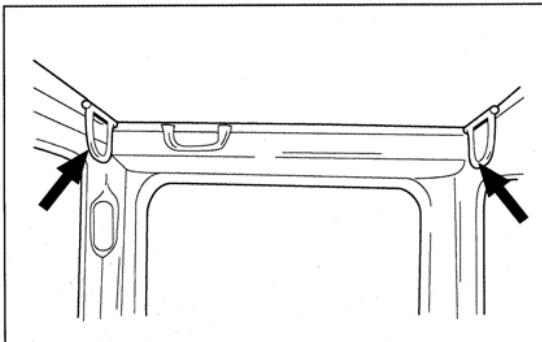

- (A) Hold the handle with hands, using first finger to open the lock catch.
- (B) Hold the front and rear handle, pull down the window slowly, don't lock the rain wiper.

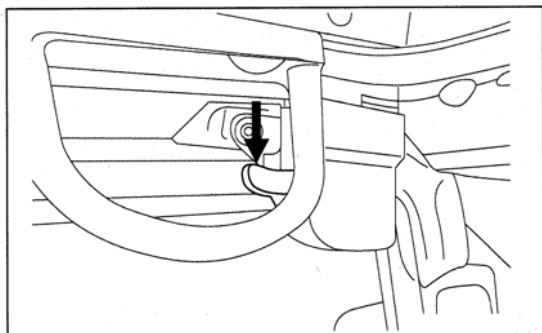

- (C) When the window slide down the right position, loosen the handle, hold and push out the window, make the lockpin into lock catch, and turn on the lock position.

CAUTION

Do not lower the front window quickly, so as not to cause injury when closing the window. The window could be shut down slowly only when the driver take a seat.

2-2-14. Open cabin door and window

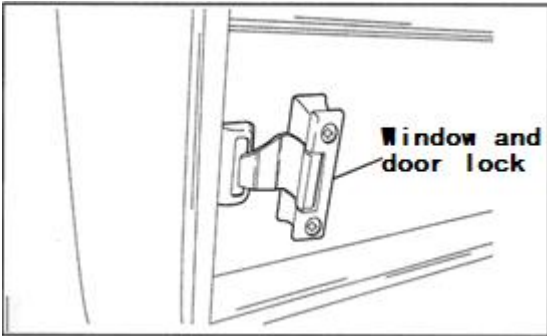

- (A) Press the lock to open the door and window.
- (B) Sliding the front window backward and the Rear Window forward.

2-2-15. Close cabin door and window

- (A) Sliding the front window forward and the rear window backward.
- (B) Be sure the lock is completely locked while closing the cabin.

2-2-16. Adjust seat

The seat can be adjusted forward and back, ensure operational comfort.

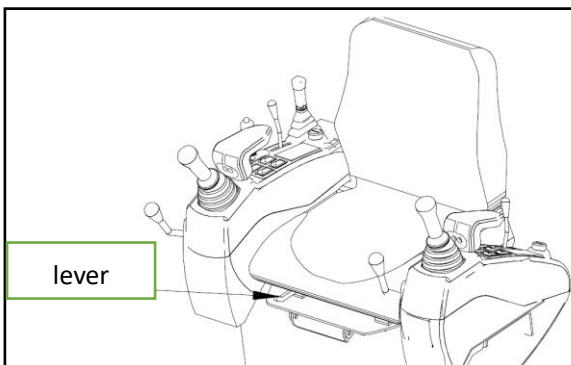

Front and rear adjustment of seat
Using the lever to adjust seat.

2-2-17. Saftey Belt

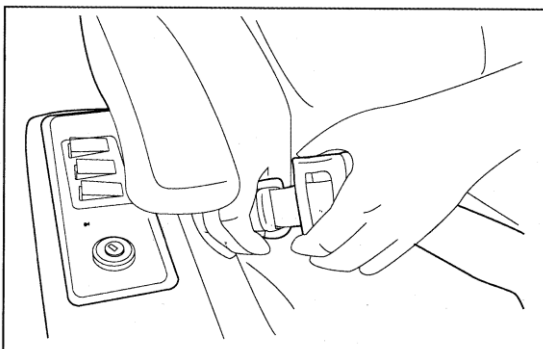

- (A) Verify the belt is not reversed, to ensure that the ends of the gently pulling the seat belt to confirm that the lock is fastened.



- (B) Adjust the seat belt to the position that is appropriate and comfortable .

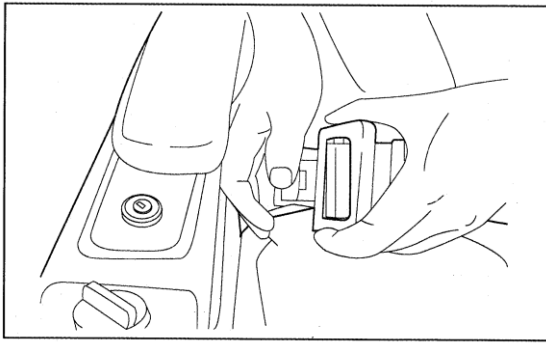

(C) Loose the belt by pressing the lock button.

Chapter 3. Machine Running-in

3-1. New machine running-in

- (A) After starting the engine, machine should work for 15 seconds at idling speed. At this time, do not operate the joystick or the fuel control knob.
- (B) Avoiding the heavy-duty operation or operating at high speed.
- (C) Except in an emergency, suddenly starting, acceleration, steering and stopping are not permitted.

CAUTION

- Before delivery, machines have been conducted a thorough adjustment and test. However, operating machines in harsh conditions at beginning would seriously affect machine performance and shorten the life of the machine.
- In the first 100 hours showing by the display instrument, machine should be running-in. During the break-in operation period, the required notice in this manual should strictly comply with.

3-2. Carefully observe the operation of the engine

- (A) Only adopting economic way and the engine power should be limited to less than 80% of full load to operate the machine.
- (B) Avoiding the engine operating at no-load speed for a long time.
- (C) While operating, operator should often pay a close attention to the indicator and display instruments.

IMPORTANT

Paying special attention to the machine in the first 50 hours, until you are completely familiar with the sound of the machine.

3-2-1. Every 10 hours or every day

- (A) To maintain the machine every 8 hours or every day according to the daily maintenance in the *Maintenance Guide*.
- (B) Be cautious of liquid leakage.
- (C) In the first 100 hours, or working in the mud and water, device pin should be lubricated every eight hours.

3-2-2. After the first 50 hours

- (A) To maintain machine every 50 hours referring to the 50-hour care in the *Maintenance Guide*
- (B) Engine oil should be replaced initially at first 50 hours.
- (C) Checking visible fastener torque referring to the maintenance portion of the fastener torque specifications

3-2-3. After the first 250 hours

The machine would be maintained every 50 hours and every 250 hours according to the maintenance guide in 50-hour and 250-hour maintenance

Chapter 4. Operation-Machine construction

4-1. Machine construction

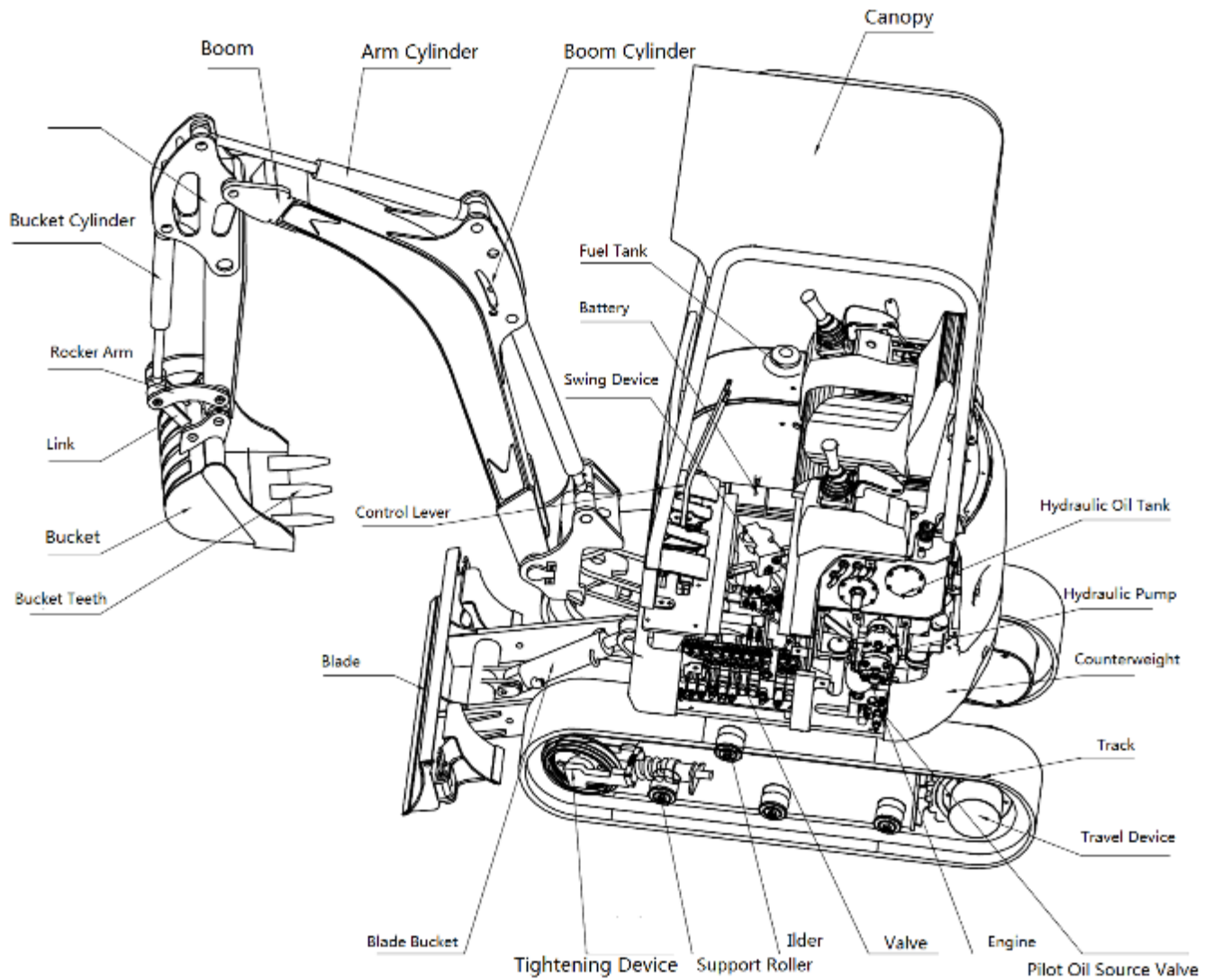

4-2. Check the machine every day before starting

For other inspection and maintenance methods, check "maintenance" section.

1. Electrical Systems

Check for worn or frayed wires and loose joints.

2. The structural parts

Boom, arm, bucket, sheet metal, track, check for bent, damaged and missing parts.

3. Fastener

Check for loose or missing parts.

4. Fuel System

Drained of water or sediment from the fuel tank.

5. Hydraulic System

Check for leaks, hose twisting, tubing or hose or the occurrence of friction between the friction phenomena and other parts.

6. Lubrication

Check the lubricating sites mentioned at the periodic maintenance book.

7. protection device

Check protection devices, fender.

8. Security

Non-staff stay away from the machine, and remove obstructions.

4-3. Check before starting the engine

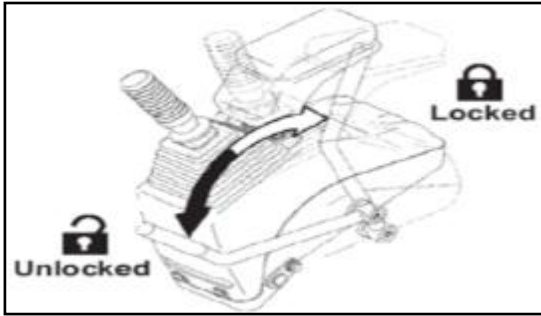

- (A) Confirming the switch lever of the pilot control is in the locked position.
- (B) Making sure that all of the operating lever is in the neutral position.
- (C) Checking the indicator lamp:
Turning the key switch to the ON position, the charge indicator will light up.
- (D) Adjusting the seat to the position where you could step the pedal to the limiting position and push the control lever to the extreme position, then fastening your safety belt.

CAUTION

In order not to damage the surface of the instrument panel, using a damp cloth to wipe the monitor or switch plate is better. Switch parts are made of rubber. Be careful not to scratch such rubber parts with a screwdriver or other sharp objects.

4-3-1. Check the Level

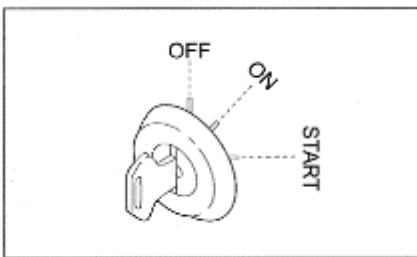

- (A) Turn the key-switch to ON position.

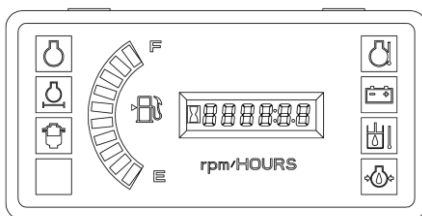

- (B) Making sure that the liquid level on the display is suitable for operation.

IMPORTANT

In order to prevent possible damage to the machine, checking all liquid level is necessary. However, such inspection could not be substitute for daily hydraulic oil tank level labeling, examination of the engine cooling water tank and the engine oil dipstick.

4-4. Starting the engine

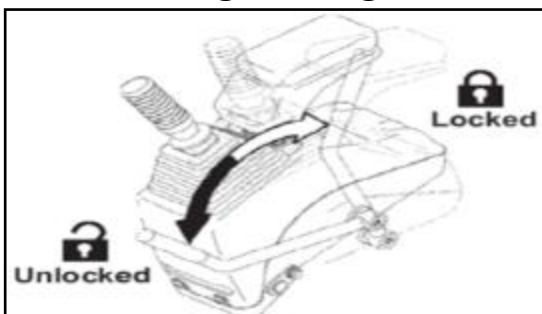

- (A) Pulling the switch lever of pilot control to the locked side.

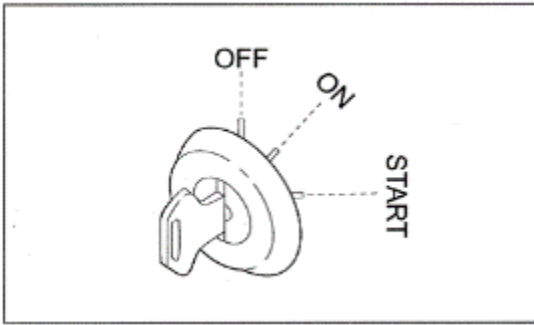

- (B) Turning the key-switch to the ON position.
- (C) Honking to alert personnel around

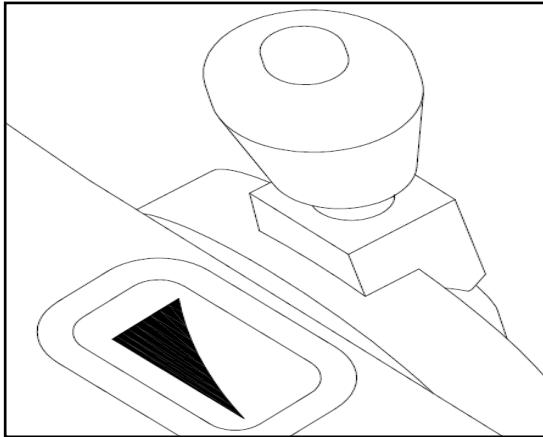

- (D) Pulled the engine throttle control lever to the idle load position .
- (E) Opening the key-switch to start the engine. Then releasing the key, switch will return to ON position.

CAUTION

In hot weather, a little higher idling speed of engine is normal, no maintenance!

IMPORTANT

To prevent the damage of starter!

- In order to avoid to damage the starter, each operation to starting motor could not exceed 10 seconds. If the engine could not be started, turning the key-switch back to the off position, and then waiting for 30 seconds and try again. If starting failure, it will damage the started if not wait until the engine stopped and then turn the key switch immediately.

4-5. After starting the engine

WARNING

● **Emergency stopping**

If there are any improper situations or faults, turning key-switch to the OFF position.

- If you operate the working device in which the machine does not have a sufficient warm-up, the reaction of the Working apparatus to the joystick movement is very slow and the working device could not be worked in accordance with the requirements of the operator. So warm-up operation is important, especially in cold areas.

4-5-1. Operating the machine in cold weather

1. Operation common sense in cold weather:

- In cold weather, the engine would not be started easily, the fuel may be frozen and the viscosity of the

hydraulic oil could be increased. As a result, please choose the suited fuel according to the actual temperature.

- When the hydraulic oil temperature is below -25 degree, the machine must be preheated before starting working.
- When the hydraulic oil temperature is below -25 ° C, no reaction or sudden fast action may occur while operating the machine, ,therefore, a serious accident would happened.

CAUTION

Coolant that we use is permanent-type antifreeze, freezing point is -35 ° C, and it would not freeze even in the cold weather. Please use our designated antifreeze, customers are not allowed to add water or other brand coolant. Most appropriate hydraulic oil temperature of excavator is above 50°C.

2. Warm-up before starting the engine

It's difficult to start the engine in cold weather, first preheating the intake system, steps as follows:

- (a) Pressing the warm-up switch.
- (b) Starting the engine after preheating 10 seconds.
- (c) After starting the engine, making sure the meter and light is normal.

3. Preheating before normal operation of the machine

- (a) After starting the engine, canceling the automatic idling mode, adjusting the throttle knob to allow the engine with no-load operation to work at low speed of 1100 rpm / min for about 5 minutes.
- (b) Adjusting the throttle knob to allow the engine to work at middle speed of 1500 rpm / min. Then operating the bucket 5 Minutes slowly back and forth.

CAUTION

Do not operate the other implementing parts except the bucket.

- (c) Adjusting the throttle knob to allow the engine to work at high speed of 2100 rpm / min. Then operating the boom, arm, and bucket for 5 to 10 minutes.

CAUTION

Only operating the boom, arm and bucket, do not operate rotary and walking.

After several complete operating to excavator action, the warm-up of the machine is successfully finished, and then the machine could begin to work normally.

4-5-2. Working in snow

- (A) Surface covered with snow or freezing is very slippery. To be especially careful when walking or operating machinery. Do not operate the lever suddenly. Even a small slope will cause the machine to slip, therefore, paying special attention when working on slopes.
- (B) For frozen ground, When temperature rises, the frozen ground will become soft, this will cause the machine tipping.

- (C) If the machine gets into the deep snow, it would be overturned or buried in snow .Be careful not to leave the hard shoulder or trap into a snow.
- (D) While cleaning up the snow, objects at Shoulder or road nearby buried in the snow could not be seen easily. Therefore the machine is in danger of tipping or hitting a buried object, so careful operation is necessary.

4-5-3. Turning off the engine (stop) Steps



- (A) Stopping the machine on level ground.
- (B) Bucket should be lowered to the ground.

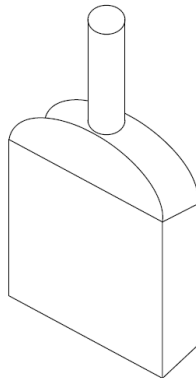

- (C) Turning the engine control knob at low speed and idle position, then operating the engine for 5 minutes so as to make the engine cooling.

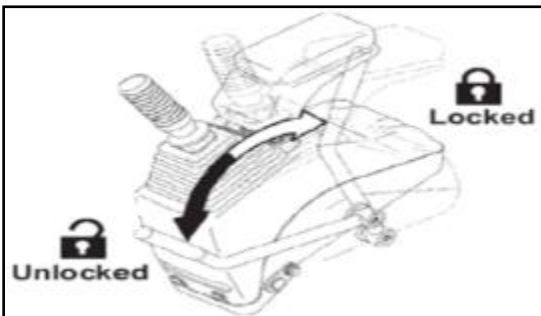

- (D) Revolving the key-switch to OFF position, and then removing the key . In addition, pulling the switch lever of pilot control to the locked position.



- If the engine is suddenly shut down before cooling, it will considerably shorten the service life of the engine. Except in an emergency, do not suddenly turn off the engine.
- In particular, when the engine is overheating, do not suddenly shut down, but operation the engine in medium-speed to cool gradually, and then turning off the engine.

4-5-4. Inspection after turning off the engine

- (A) Making an overall inspection of the machine, checking the working device, outside of the machine, the lower part of the vehicle and also checking for spilling or leaking, abnormal condition should be repaired.
- (B) Adding fuel to the fuel tank.

- (C) Checking the engine compartment with paper and debris and clearing in order to avoid the risk of fire.
- (D) Removing the soil attached in the lower part of the machine.

4-5-5. Preparation for moving machine

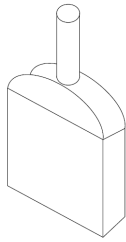

Push the throttle lever forward to increase engine speed

⚠ WARNING

- Before operating the steering lever, check the direction of the crawler frame.
- If the drive wheels are in the front, the travel lever operation is reversed.
- Ensuring that it is safe around the machine and honking before moving.
- Do not allow anyone around the machine.
- Clearing all the obstructions on the walking route of the machine.
- The rear area of the machine is a blind spot; more attention should be paid when reversing walking.
- For those machine equipped with an optional walking alarm, making sure the alarm device is working properly.

4-5-6. Driving machine cautiously

⚠ IMPORTANT

- In cold weather, Parked the machine on the hard ground, to avoid tracks freezing together with ground. Clearing debris on the track and track fram.
- If the track and ground freezing together, lifting up crawler with boom and move machine with caution so as to avoid damage to the drive wheels and tracks.
- Parked on flat road, and operate the direction in straight-line or small subtle shifts as much as possible.
- When driving on uneven ground, slowdown the engine speed so that to reduce the possibility of damage to the track and the lower body.

4-5-7. Taking advantage of pedal to drive the machine

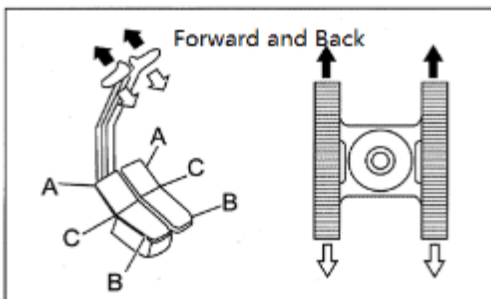

- (A) Walking Forward
Pushing the front portion of the two pedals-A
- (B) Walking Backward
depressing the back portion of the two pedals -B
- (C) Neutral Position C
When the walking pedal is in the middle position, the walking brake is automatically in the braking state.

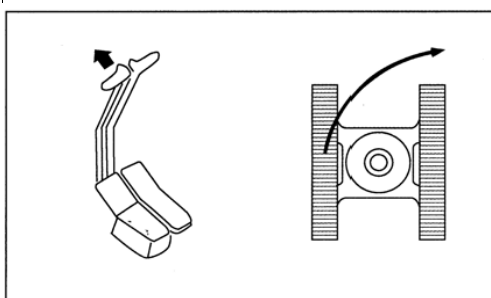

- (D) Turning right
Stepping the front part of the left pedal
- (E) Turning left

Depressing the front side of the right pedal.

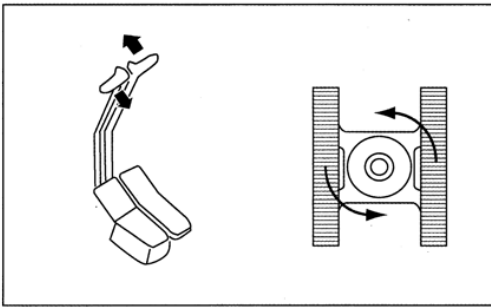

(F) In situ rotation (autogyration)

Depress the rear position of a pedal and another the back of another pedal.

CAUTION

- Standard walking position: The guiding wheels are in the front of the machine and the traveling motor in the rear. If the traveling motor is in the front, controlling direction of the traveling pedal is opposite to the running direction of the machine.
- Verifying the position of the traveling motor before walking.
- While long-distance walking, walking 20 minutes and resting for 5 minutes, so as not to damage the traveling motor; for smooth operation, walking pole is provided with a damper. In cold weather, the operating force of walking pole will be increased, in this case, operating the walking pole several times firstly, while the switch lever of pilot control is still in locked position.

4-5-8. Using the operating pole to drive

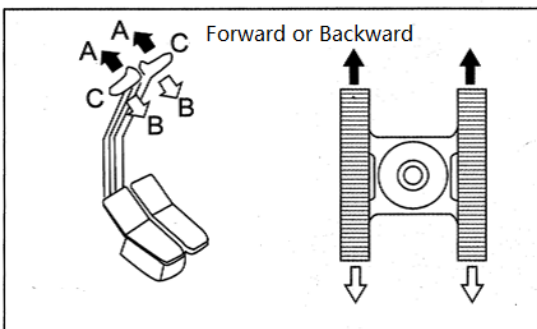

(A) Walking Forward

pushing two walking poles forward-A

(B) Walking Backward

pulling two walking poles backward -B

(C) Neutral Position C

When the walking pedal is in the middle position, the walking brake is automatically in the braking state.

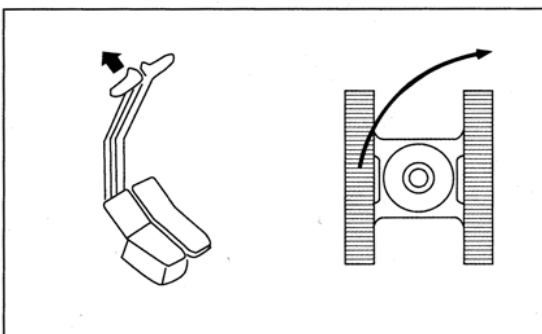

(D) Turning Right

Pushing left walking pole forward

(E) turning left

Pushing right walking pole forward

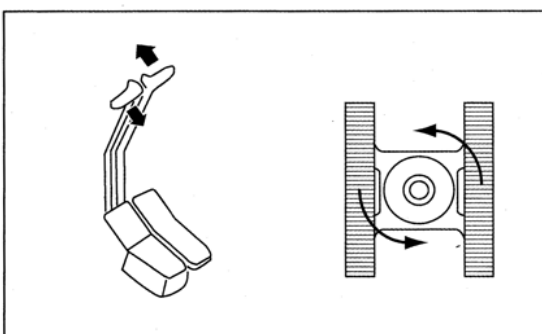

(F) Spot turn(Rotation)

Pushing a walking pole forward and pulling the other pole backward.

CAUTION

- Standard walking position: The guiding wheels are in the front of the machine and the traveling motor in the rear. If the traveling motor is in the front, controlling direction of the traveling pedal is opposite to the running direction of the machine.
- Verifying the position of the traveling motor before walking.
- While long-distance walking, walking every 20 minutes and resting for 5 minutes, so as not to damage the traveling motor; for smooth operation, walking pole is provided with a damper. In cold weather, the operating force of walking pole will be increased, in this case, operating the walking pole several times firstly, while the switch lever of pilot control is still in locked position.

4-6. Walking



CAUTION

When walking, turning or operating machine in confined areas, a signalman is necessary. Coordinating signal before starting the machine.

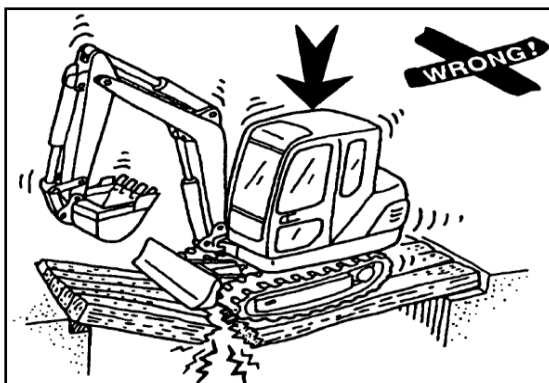
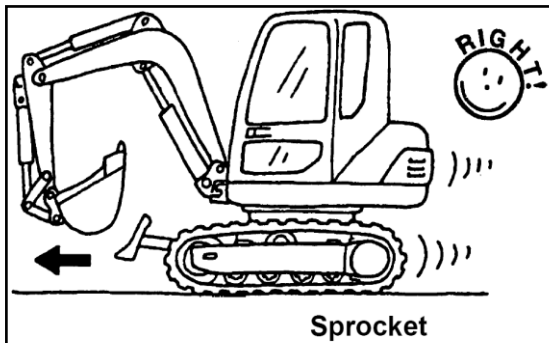

- (A) Before moving the machine, operator have to make sure the direction of travel and walking control pedal / lever are the same. When traveling motor is in the rear, depressing the front part of the walking pedal, or pushing the walking poles forward, the machine will walk forward.
- (B) Selecting a flat ground and driving machine in straight line as much as possible and changing direction small and gradually.
- (C) Before walking, check the hardness of the sub grade and bridges. Strengthening if necessary.
- (D) Using planks in order to not damage the road surface. Drive carefully when walking on asphalt road in summer.
- (E) Use wood when crossing the orbit, in order to not damage.
- (F) Machine should not contact with wire and the eage of bridges.
- (G) While crossing the river, firstly, measuring the depth of the river with bucket, and then across the river slowly. Do not cross the river while the water over the upper edge of the chain wheel.

- (H) When walking on uneven areas, reduce the engine speed. Walking in low speed. The slower speed will reduce the possibility of damage to the machine.
- (I) In freezing weather, when loading and unloading the machine, clean up the snow and ice on the track, so as to prevent slipping



Walking note: To avoid the abnormal fault of travel motor, Prohibit self-propelled walking with travel motor more than 2km, Radiating per 15 minutes.

4-6-1. Controlling and operation of working device

Operating working device by control lever.

While loosing the control lever, it will be back to the neutral position; working device keeps in the position.

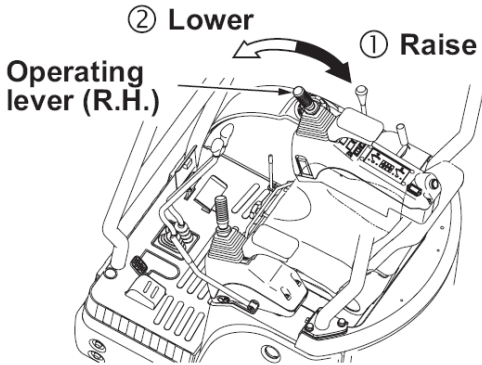
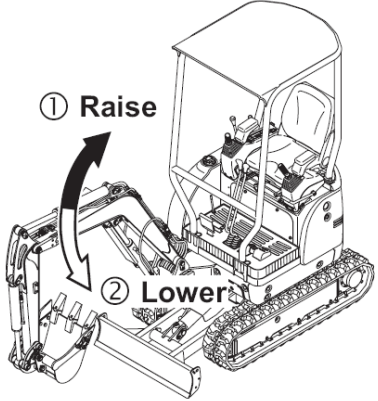
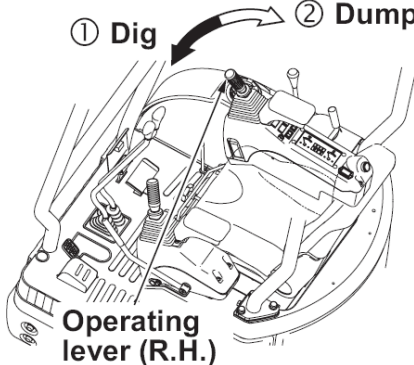
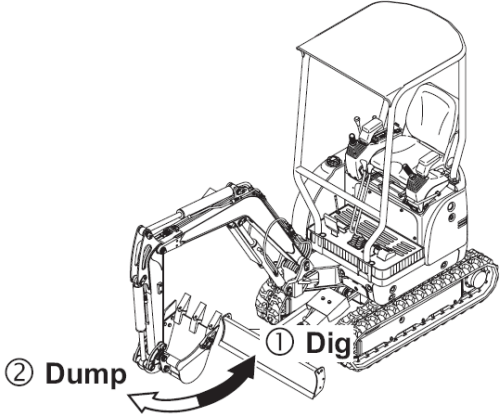
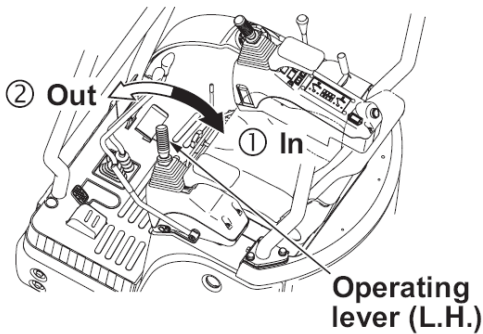
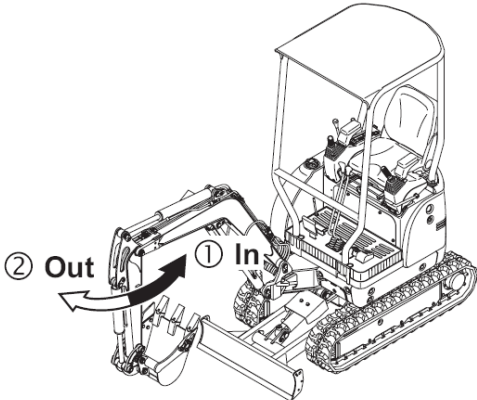
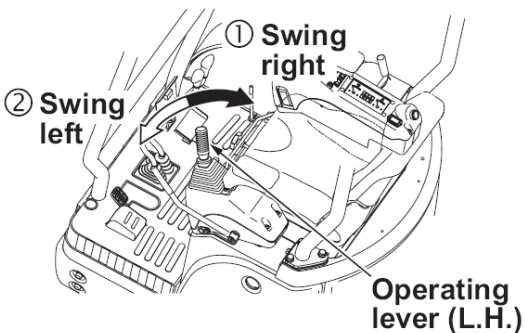
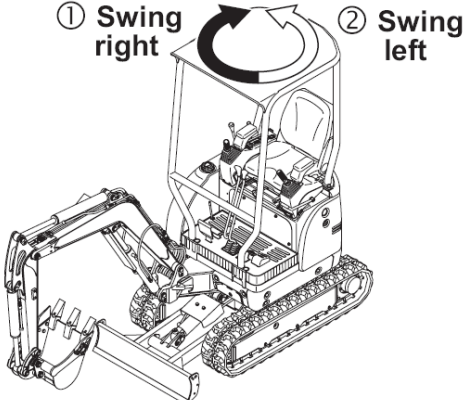
OPERATIONS	DIRECTION OF LEVER	DIRECTTON OF MACHINE
<p>BOOM</p>		
<p>BUCKET</p>		
<p>ARM</p>		
<p>SWING</p>		

OPERATIONS	DIRECTION OF LEVER	DIRECTION OF MACHINE
<p>BOOM SWING</p>		
<p>BLADE</p>		

⚠ WARNING

The working device would move very quickly if operating the working device joystick quickly; if operating slowly, the working device would move slowly.

4-6-2. Prohibiting operation

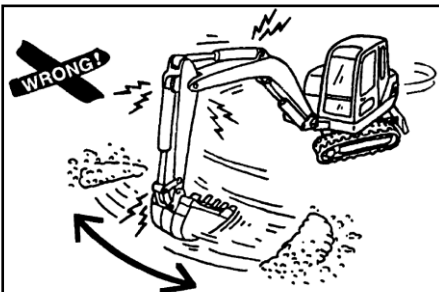

(A) Operation by using rotating force

Do not use rotating force to compact ground or break objects. It is not only dangerous but also shorten the life of the machine significantly.

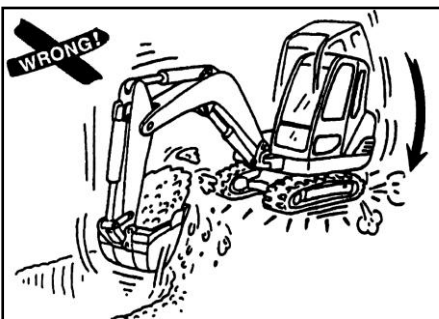

(B) Operation by using travel force

Using walking force to digging instead of bucket, or it would damage to machine and attachments.

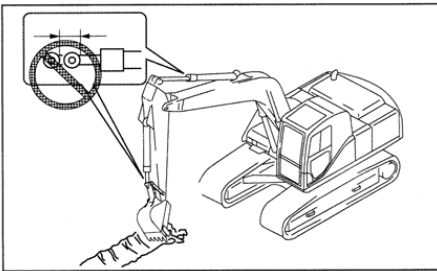

(C) Operation by using the end of the hydraulic

- During operation, when cylinder piston rod has been stretched to the end of the stroke, if the cylinder is still working, the external force would cause the impact on the work device, which will damage the hydraulic cylinder.
- In the case of the hydraulic cylinder is fully retracted or fully extended, do not operate the machine.

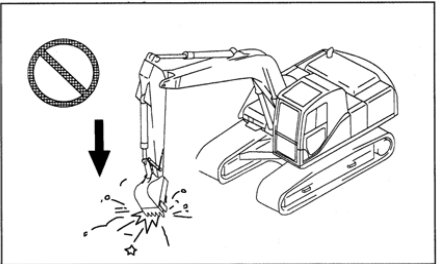

(D) Operation by using the Bucket down force

Do not use the downward force of the machine to dig or using bucket downward force as a hand-ho, broken or piling machine. This may significantly shorten the life of the machine.

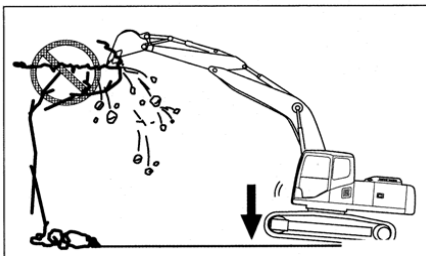

(E) Using Operation of machine-down force

The downward force should not be used for digging.

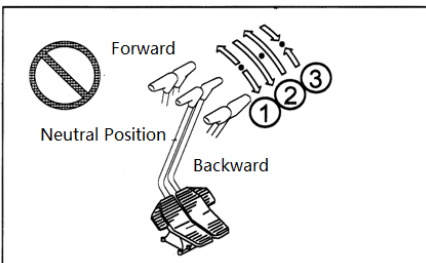

(F) Digging hard rock ground

It's better to breaking in other ways firstly, and then digging. It is not only reduce the damage to the machine, but also more economical.

(G) suddenly transition to high-speed walking.

Do not make sudden conversion of the joystick, as this could cause sudden starting.

Avoiding sudden transition of joystick from forward to backward (or from retrogression conversion to forward).

Avoiding sudden conversion joystick (for example, from the high-speed suddenly stopped (release the joystick).

WARNING

- Especially be careful if u have to operate the joystick when walking.
- If you operating any joystick,the engine speed will suddenly increase when idling is working, pay attention to it when operating.

4-6-3. Walking on the slopes

When walking, raising up the bucket from the ground about 20 - 30cm (8 - 12in).

Do not walking downhill by backwards.

- When walking on the bumps or other obstacles, making the device close to the ground and walking slowly.
- Do not turn on slopes or across the slope.
- Operating on a level place. This will be much far, but safety.
- Operating or driving according to rules, even if it is slip or become unstable, and also can be stopped safely.
- When working on slopes, turning or operating the device will causes the machine lose balance and fall over, so avoid these operations.
- When the bucket is equipped with load, the rotation direction of the downhill is very dangerous.
- If you must carry out this operation, piled up a platform on the slopes, to keep balanced when operating..
- Do not drive onto or driving down steep hill, it has the risk of the machine tipping.
- When walking uphill, if the track shoe is slip or relying on the power of the track can not be uphill, do not use the stick Rally help machines uphill, so there will be the risk of the machine tipping.

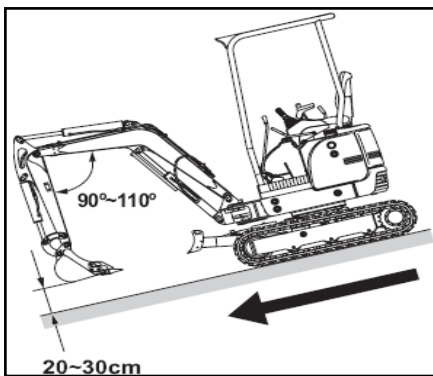
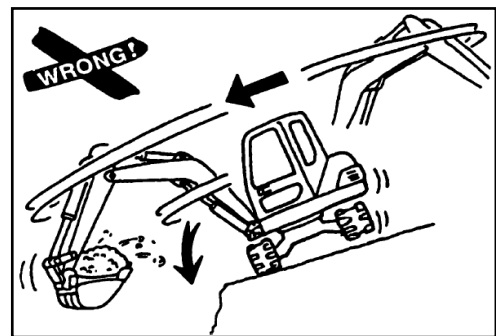
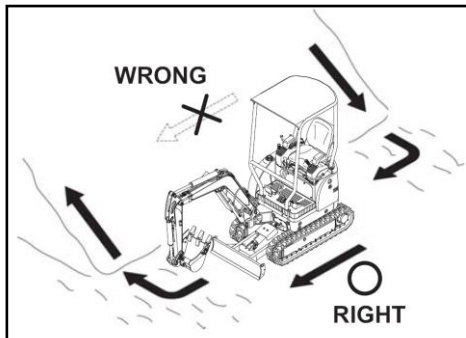

When walking on the steep slopes, using the walking joystick and fuel joystick to keep low-speed traffic. When walking downhill on a steep slope with gradient of more than 15 °, as shown in the left, you should transferred the working device to the position and lower engine speed.

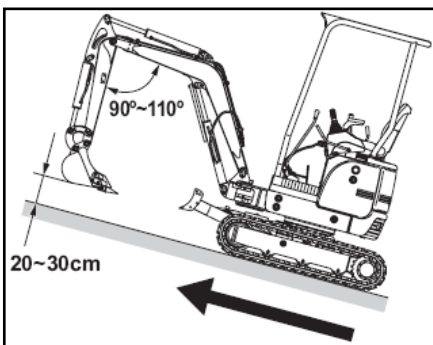

On the steep slopes of more than 15 °, turn into the working device as the state shown in the left.

(A) Walking downhill

In downhill walking, in order to brake the machine, placed travel lever to middle position, the brake will be automatically applied.

(B) Tracks slippery

When walking uphill, soleplate may slip or to the crawler power can not uphill, you can use the arm help machines uphill.

(C) The engine is stopped on a slope

When uphill, if the engine is shut down, move the joystick to the neutral position, and then start the engine. When the machine is on a slope, if the engine is stopped, do not rotation operation by using the left side working device joystick . The upper part of the body will be rotating automatically.

(D) Door of cabi

When the door opening or closing on the slopes, be extra careful. The weight of the door causes the door suddenly opened or closed.

Must make the door firmly locked.

4-6-4. Machine parked on the ramp

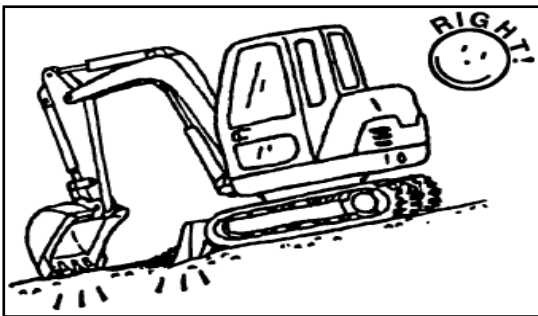

- (A) Bucket teeth insert into the ground
- (B) the respective operating lever is returned to neutral, and The pilot control switch is pulled to the locked position.
- (C) with a stopper to withstand both sides of the crawler.



Avoid parked the machine on a slope, the machine may tip, resulting in injuries!

4-6-5. Parking machine

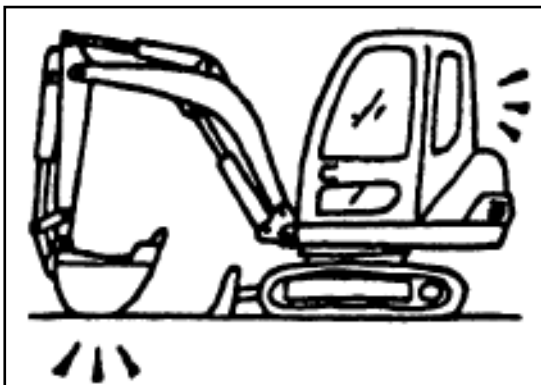

- (A) Parking the machine on level ground.
- (B) Lower the bucket on ground.
- (C) The engine control knob counterclockwise to the limit position. (Low-speed no-load position).Operate the engine of about 5 minutes to allow the engine to cool down.
- (D) Pull the pilot control lever to the locked position.
- (E) Turn the swith of key to the close position,remove the key.
- (F) Close the door,window
- (G) Lock all access doors and box room.



To protect the electrical components in cabin in the rainy days, you must close the window, skylights and the driver's door when the machine is parked.

4-6-6. Operation in water or mud

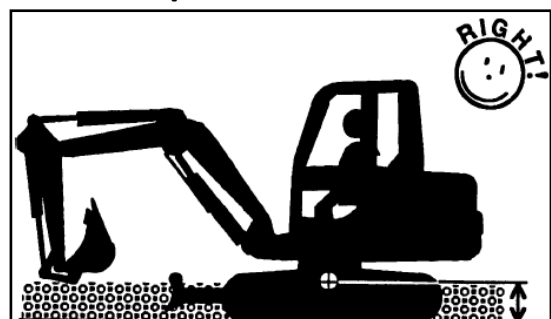

- (A) When the work area of the foundation have enough strength to avoid machine sinking over the upper edge roller, can let the machine in operation is lower than the upper edge of the water roller.

- (B) When operating in this environment, you should always check the location of the machine. If necessary, you can update adjustment the position of the machine.
- (C) Avoid immersion slewing bearings, slewing gear and central rotary joint.
- (D) If the slewing ring, slewing gear and the central rotary joint is flooded, remove the drain plug to rule out the mud and water, cleaning the swing area, fitted plug. Lubricated rotary internal gear and slewing ring.

4-6-7. Drag out from the mud

Should always be careful to avoid falling into the mud. If the machine is sunk in the mud, according to the following steps to take the machine out.

1. One side of the crawler sunk into mud

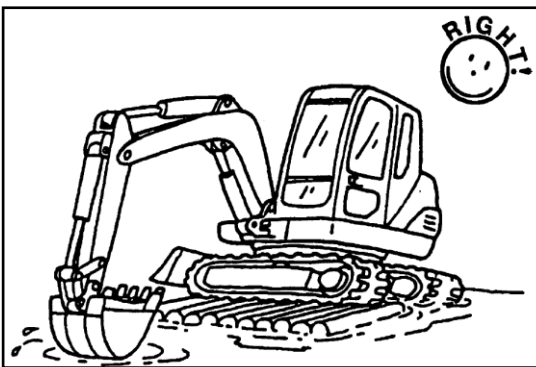

- (A) When using the boom or arm to lifting the machine, be sure to make the bottom of the bucket in contact with the ground. (Do not use bucket teeth push).The angle between the boom and the arm should be 90 ° to 110 °., The same applies when using the opposite bucket.
- (B) When only one side sunk into sludge,using the bucket to lifting the crawler, then pad planks or logs, pulled out of the machine. If necessary, put the bottom of bucket below on wood.

2. Both sides of the crawler sunk into mud

If both sides of the crawler are sunk into mud, and the machine can not move , pad timber according to the method described above, and dig the bucket into the front ground, and follow the same method as the mining operation to pull the bucket lever, and the travel lever placed in the forward position, pull out of the machine.

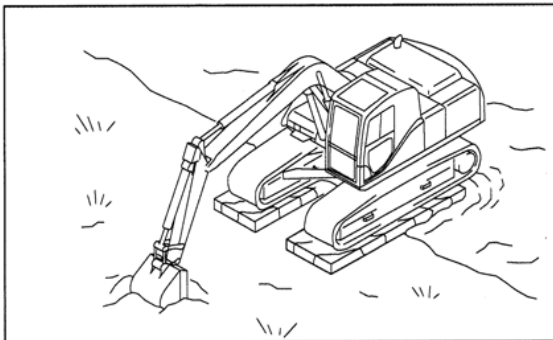

4-6-8. Operation in soft ground

Avoid to operation in the soft ground that absence of sufficient strength to support the machine

If the machine is working on very soft ground or stuck, you may need to clean the crawler frame.

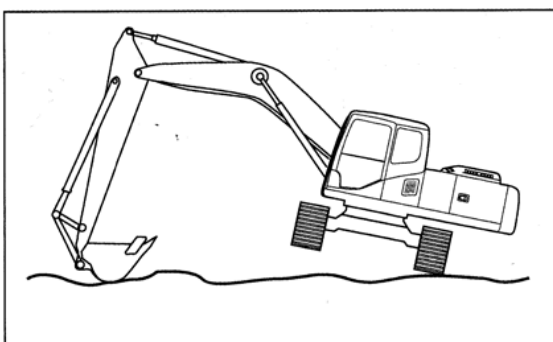

- (a) ou should turn the upper and lowered the bucket, so as to raise one side of the track to leave the ground. The angle between the boom and the arm is kept at 90 degrees to 110 degrees, the arc of the bucket placed on the ground.

- (b) Get rid of the dirt on the crawler by rotating the promoted track .Put the crawler on the ground, reduce the walking speed, carefully move the machine to the solid ground.
- (c) Use the boom and arm to pull the machine onto the solid ground.
- (d) If the machine is stuck in the mud, but the engine is still working, you can drag the machine. Be sure to correctly fitted towline. (Refer to the next on the short-range tractor section)

4-6-9. Using boom and arm to raise one side track

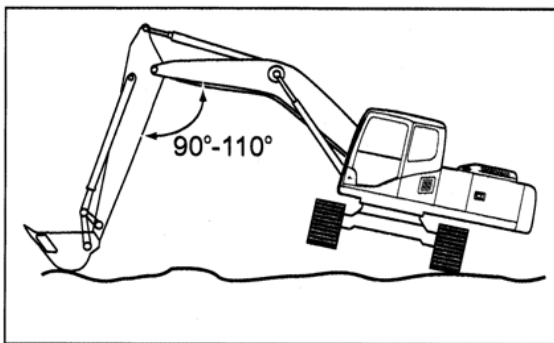
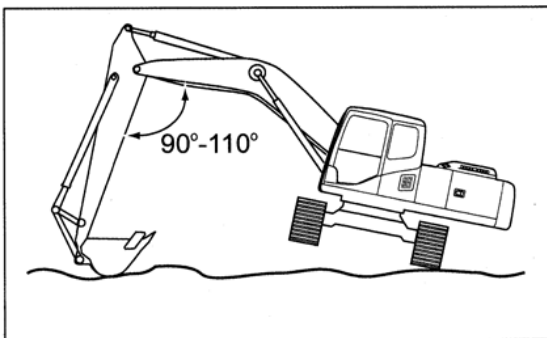

CAUTION

- Keeping the angle between the boom and arm within 90 to 110, and place the bucket arc on the ground.
- To rotation 90 °on the upper and lowered the bucket to enhance crawler off the ground. When using a backhoe, bucket teeth should not boring ground.
- Placed pad in the bottom of the machine frame to support the machine.

4-6-10. Short-range pull out machine

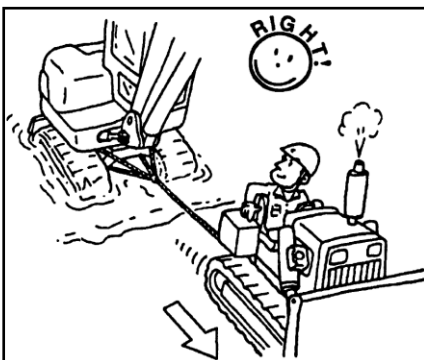

If the machine fell into the mud and its own power can not be pulled out or excavator index rod is used to index weights.

- (A) Must always wearing gloves when handling wire rope, tape or rope.
- (B) As shown, the cable connected to the drag, and use other machines to pull your machine to the solid ground.
- (C) The cable must be connected to the two machines walking shelves.
- (D) To avoid cable wear off, placed protective material between walking frame and cable .

- (E) Using the appropriate hook-and-loop, tied the drag-and-drop cable on the machine frame.
- (F) Keep the cable in the horizontal, and in accordance with the track direction, slowly drag.
- (G) When pull the machine , by operating the walking poles to open the walking brake.

WARNING

- Use the wire rope which has enough strength to withstand the weight of the machine when traction machine,
- Cable, tape or rope may fracture, resulting in serious injury or death. Do not use damaged chain, worn wire rope, ring hook, belt or rope to pull out the tractor.
- Do not apply loading to the wire rope suddenly.

4-6-11. Light load towing hook

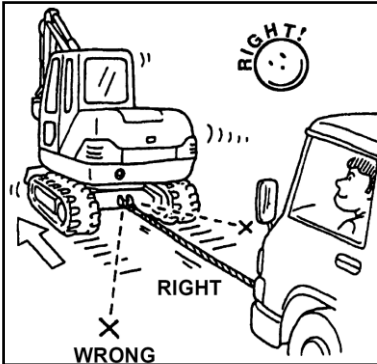

The track frame equipped with a hook to pull the lightweight.

WARNING

- You must use the shackle.
- To maintain e the wire rope horizon and face the track frame.
- Select low speed walking; slowly move the machine in drag.

4-7. The control lever

WARNING

- Don't put your any part of the body out window frame. If you accidentally touch the controlling lever, you will have the risk of injury by boom.
- If there is the case of loss or damage to the window frame, should immediately make up or replaced.
- Prevent accidental movement of the machine and cause injury.
- Before the operation, to be familiar with the location and function of each joystick.
- Avoid bucket hit the track when excavation is undergoing. When forwards and backward excavation, the travelling motor should be in the back, so that the stability and the lifting capacity of the machine will be maximum.
- After the release lever, it will automatically return to the neutral position. Machine functions will stop. Swinging and the working device operation means are controlled by two levers.

Figure: Move the lever diagonally can simultaneously achieve two functions, do compound movements.

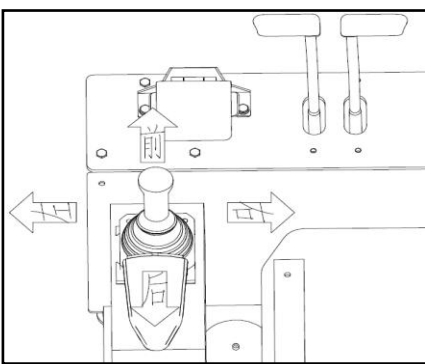

Left controlling lever

Action	
Forwards	Arm unloading
Backwards	Arm digging

Left	Swing to left
Right	Swing to right

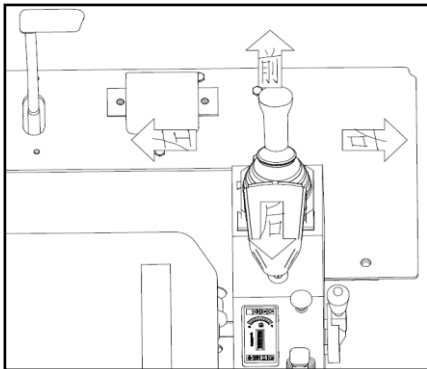

Right controlling lever

Action	
Forwards	Boom drops
Backwards	Boom hoist
Left	Bucket digs
Right	Bucket dumps

4-7-1. The pilot lever (safety lever)

When operator leaves the seat and the cab, the operator may have accidentally touched the Pilot Controlling lever, the Safety controlling lever can be used to prevent such misuse.



- Pilot control switch lever must be pulled fully in locked position. Otherwise it is turned on.

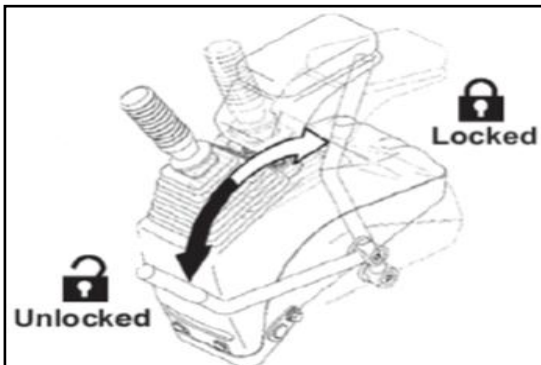

(A) When leaving the machine:

- Stop the engine.
- Then the pilot pulled the switch lever to lock position.

(B) To ensure that the pilot control lever is pulled off the locked position.

- When transporting the machine.
- Day work is finished and leave the machine.
- When the engine starts

(C) The operation of the lever

- Before leaving the machine
The machine stops on firm, level ground. The bucket is put down on the ground. All lever back to the neutral position. Properly turn off the engine. The pilot pulled the switch lever fully locked position.
- Before starting the engine:
Confirmed that the pilot control of the switch lever in the locked position.
- After starting the engine:
Make sure that all levers and pedals are in the neutral position, and the machine ministries without motion. The pilot controls the switch lever down to open position.

In all manipulators are in the neutral position, when the switch lever down to release the pilot position, if any part of the machine (appears) to move, indicating the machine is defective. At this time, the pilot should immediately switch lever back to the locked position, and stop the engine. Then contact your dealer or Carter Heavy Industries.

4-7-2. Control the speed of engine

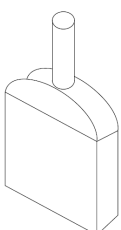

As shown in the picture, press the button on the throttle control lever, the

lever is pushed forward, the engine speed increases.

Before stopping the engine, the engine throttle control lever must be pushed back to the limit position (low-load setting). Run the engine for 5 minutes to allow the engine to cool. Then the key switch to the OFF position to stop the engine.

4-8. Precautions of working

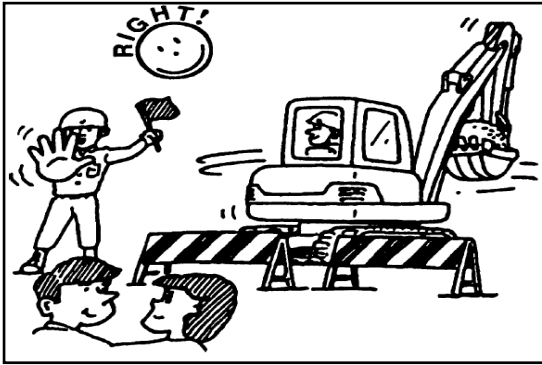

- (A) When operating the machine, be sure to wear tights, helmets and other safety products suitable for work.
- (B) All persons should be far away from operating machine, clear all obstacles. Aware of your surroundings at all times during the operation. When working in the obstacles around the narrow range, be careful not to let the superstructure hit obstacles.
- (C) Loading for truck head, lift the buckets from the rear side of truck to the top of truck. Do not lift the bucket through the top of the cabin of the truck or anyone else's head.

⚠️ WARNING

- Check the venue before starting work, when working in the conditions that objects may fall, be sure to install the cabin overhead guard.
- If you need to work on the soft, should be fully strengthen the ground.

4-8-1. Safety operation machine

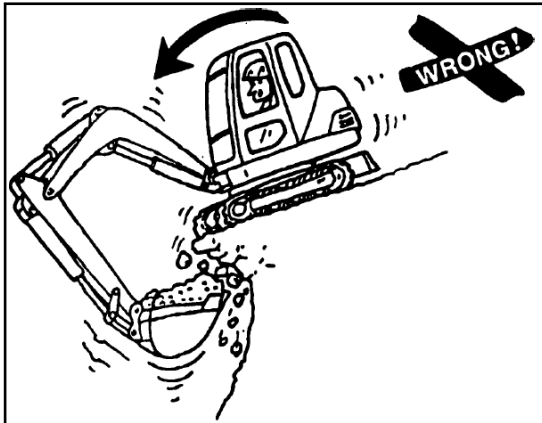

Prevent the effect of turning and tilting the ground collapse, pay attention to the following matters:

- (a) Make sure that the site of the operations have sufficient strength to firmly support the machine. When working in the groove hole or shoulder, the track perpendicular to the wall, traveling motor in the rear to operate the machine, Thus, even if the wall collapse, the machine can be easily evacuated.
- (b) If you need work in the cliff or gaoya under job, be sure to examine the work area, confirm that there is no danger of collapse of the cliff or riverbank. If there is the danger of collapse of the cliff or riverbank is present, do not operate in the region
- (c) When operating the machine in the soft ground, the ground could collapse, causing the machine to tip over. When operating on soft ground, it is important to strengthen the ground first with a big steel plate to support the machine.

⚠️ WARNING

Machine on the uneven ground or slopes may occur tipping. To prevent rollover accidents, when working in the uneven strip or on the slopes:

- 1) Slow down the speed of the engine.
- 2) Select slow walk way.
- 3) Slowly operate the machine, and pay attention to the movement of the machine.

4-8-2. Recommend working

⚠ IMPORTANT

- When lowering boom, should avoid sudden stop. Otherwise, the impact loads may damage the machine
- Operating the arm, should avoid the hydraulic cylinder extends to the end, to prevent damage to the hydraulic cylinder.
- When digging in one angle, you should avoid the bucket hit the track.
- Should avoid the boom or bucket cylinder hoses impact with the ground when digging deep groove.

1. Backhoe buckets operating

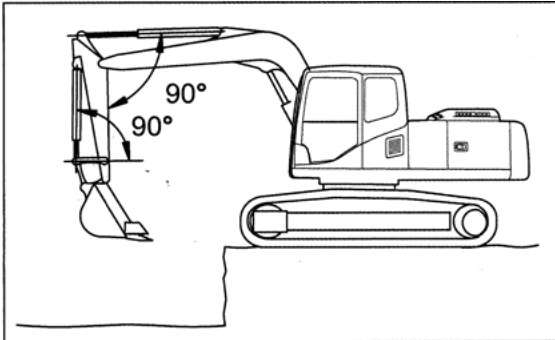

- (A) Backhoe is suitable for mining at a position below the machine .
- (B) When the machine is in the state shown on the left, that is, when the bucket cylinder with linkage and bucket cylinder rod with stick of appre 90 °, the biggest push digging force of each cylinder is available.

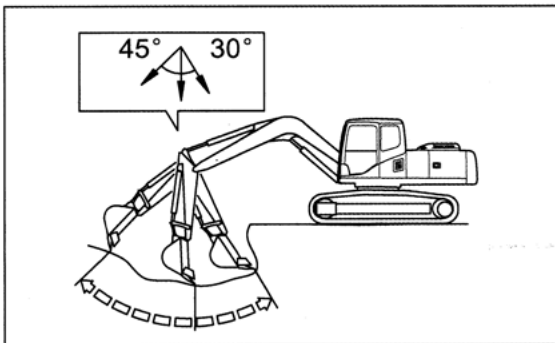

- (C) The effective use of this perspective, can make the best of the work efficiency.
- (D) Stick digging range is from 45°angle towards the machine 30 ° angle.
- (E) According to the mining depth may be different, but try to operate in the range, and do not operate the cylinder to the end of travel.
- (F) When the the soil adhesion bucket, quickly move back or forth arm and bucket (or) to get rid of the dirt.

2. Forward bucket

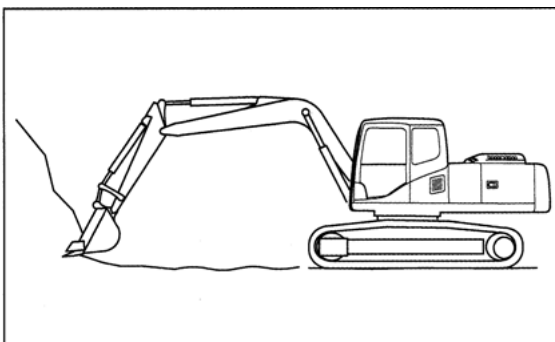

Forward bucket is suitable for digging at a position higher than the machine. Can be installed in the opposite direction bucket to achieve shovel operation.

3. Trenching Operation

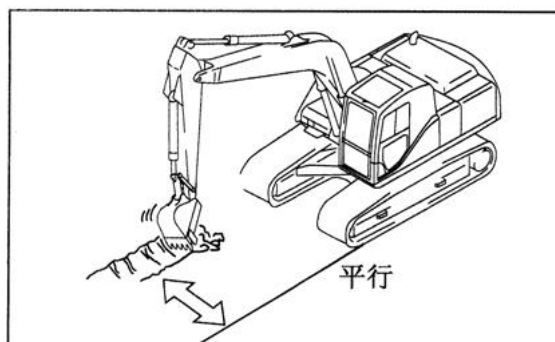

- (A) Installation the bucket matched with the width of the groove , and tracked transferred with the mining ditch parallel position, trenching operation can be performed.
- (B) Dig a wide ditch,first of all to dig out the sides, finally dredge the central part.

4. Loading operation

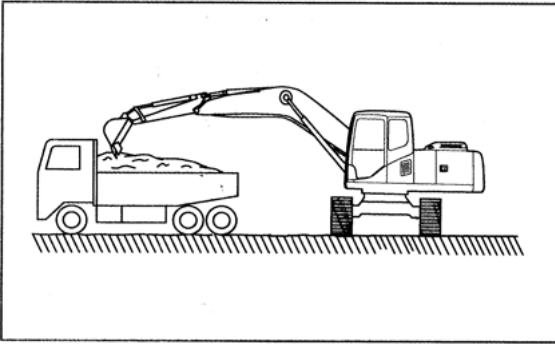

- (A) In place with a small angle of rotation, the dump truck parked in the place of the operator is easy to see, so that the job can be carried out more effectively.
- (B) Loaded from the rear of the dump truck is more convenient than loading from the side of the dump truck, a greater loading capacity.

5. Smooth operation

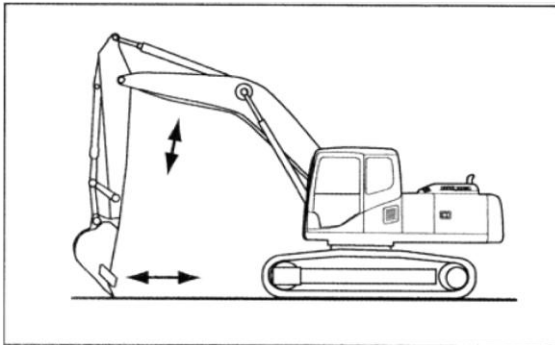

- (A) When we need to do the firm work, select the flat way. As shown in Fig., the rotating bucket placed to the slightly forward position of the arm. Slowly lift the boom at the same time recover, Once the arm moves more than a vertical position, slowly lower the boom so that the bucket can be maintain the level of plane motion.
- (B) Operating the boom, arm and bucket at the same time can make the leveling operation more accurate.

⚠ IMPORTANT

When walking, you should not pull or push dirt by bucket.

4-8-3. Avoid improper digging

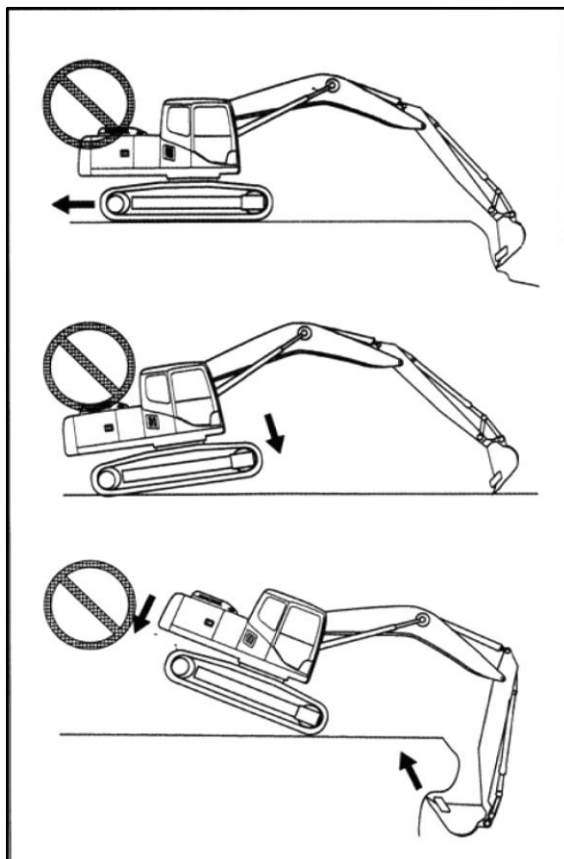

- (A) Do not take walking as additional digging force, this will cause serious damage to the machine.
- (B) The impossibility to enhance the rear of the machine in order to take advantage of the weight of the machine as an additional digging force. This can cause serious damage to the machine.

4-8-4. Operating skills

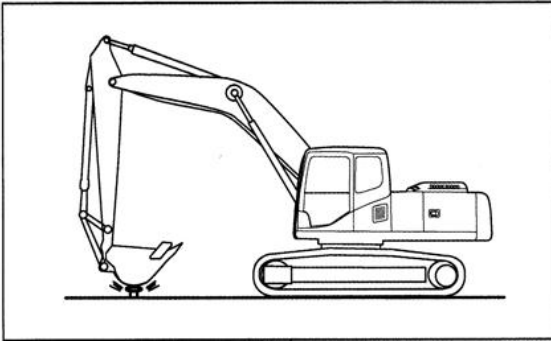

- (A) Mining, do not let the bucket collision crawler.
- (B) As far as possible park the machine on level ground.
- (C) Do not use the bucket as a hammer or piling machine.
- (D) Do not try to use rotary action to move the stones, broken walls.

! IMPORTANT

- In order to avoid damage of the hydraulic cylinder, do not make the bucket hit the ground, or tamp bucket when the bucket cylinder fully extended (bucket full recovery).
- Do not try to fully extend arm and throw the bucket, bucket teeth penetrate the ground, to dig up the rock. This can cause serious damage to the machine.

- (E) Adjustment of mining depth and length, so that each can do full mining.
- (F) Full load excavation is faster cycle production than part of each excavation bucket.
- (G) In order to increase the production capacity, the full load is the first goal, and then the speed.
- (H) Once the ditch was dug, bucket can be embedded in the soil to dig out the rock, each time digging one or two level, first dig out the top soil layer.
- (I) Do not let the bucket withstand side load. For example, do not swing bucket to flat materials or impact objects by bucket from side.

4-8-5. Select the appropriate track shoe

! IMPORTANT

- Using Wide track over rough terrain will lead to the bending of the track and (or) relaxation, as well as possible damage to the other components of track.
- Do not use wide track shoe in rock, the heap sand or gravel rough ground, wide track shoe is designed for soft ground.
- Must periodically check the tightness of the track shoe bolts.

4-8-6. The Precautions of parking the machine



- (A) After one day's work, parking the machine on a firm, level ground to without falling rocks, ground landslides or floods. Parking machine refers to the "driving machine" part , stop the machine.
- (B) To the fuel tank with fuel.
- (C) Cleaning machine
- (D) If the ambient temperature is lower than -35 °C, all cooling water should be discharged from the radiator and the engine shell(Carter used antifreeze freezing point of -35 ° C). If cooling water is discharged, be sure to hang "radiator anhydrous" sign in a visible place.

⚠️ WARNING

The Precautions of parking the machine: Shut off the power. Charge and discharge the battery regually to maintain the battery.

4-9. Road transport

When transport machine on the road, should first understand and comply with all local laws and regulations.

- (A) Transport by trailer, verify length, width, height and weight of the trailer for loading machine.
- (B) Prior to examine the status of transport routes, such as size, weight limits and traffic regulations.
- (C) Sometimes need to break down the machine to meet the size or weight limits of local regulations.

⚠️ CAUTION

Transport weight and size may vary depending on the type of track shoe and the working device loaded.

4-10. Loading machine

⚠️ WARNING

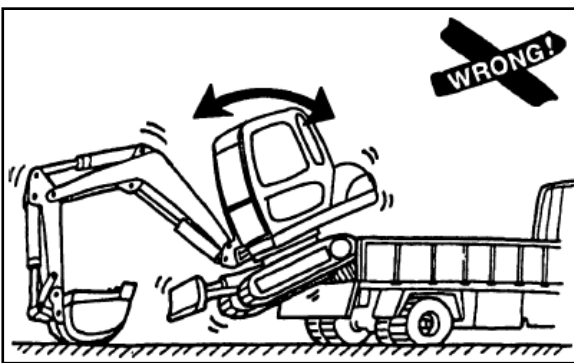
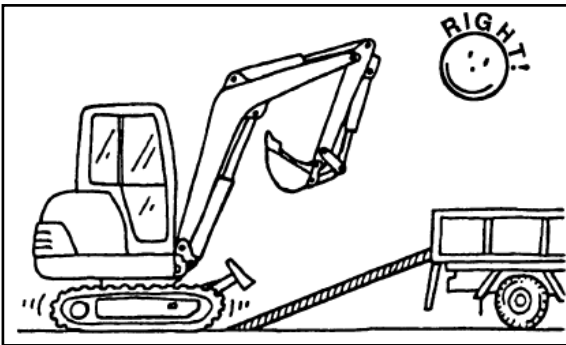

- (A) When loading machine, be sure to turn off the automatical idle switch ,to avoid a sudden increase of the speed of the machine caused due to careless operation of a control rod.
- (B) Walking speed switch should be set on low speed. And do not operate the walking speed switch, avoid high-speed mobile dangerous.
- (C) Rotate the speed adjustment knob to keep the engine running at a lower speed.
- (D) Loading, unloading the machine, to select a solid, flat ground. Keep a safe distance from the edge of the road.
- (E) Use a sufficient width, length, thickness and strength of the ramp,while install slope up to 15 °, when using the piled soil slopes, compact the bulldozers , and take measures to prevent the collapse of the slope.
- (F) Driving up or down the slope, the steering is extremely dangerous and must be avoided. If you need to turn, you should first return to the ground or trailer plate, then correct the walking direction, and then through the inclined plane.

- (G) The top of the inclined plane with the phase of the Trailer flat-panel can inform the a protrusions-shaped, you should be careful.
- (H) To prevent the the dumping of machine that may occur in the rotary of on the train and lead to injured. Shrink ,reduce the bucket rod and slowly turn the upper to get the best stability.
- (I) When walking in the the ramp,except the joystick,do not manipulate other joystick.
- (J) Before Loading and unloading, clean ramps or loading docks and trailer plate thoroughly. The piles of oil-, soil or ice inclined plane, loading and unloading table and the Trailer flat-panel there may have a risk of slippery.

4-10-1. Loading

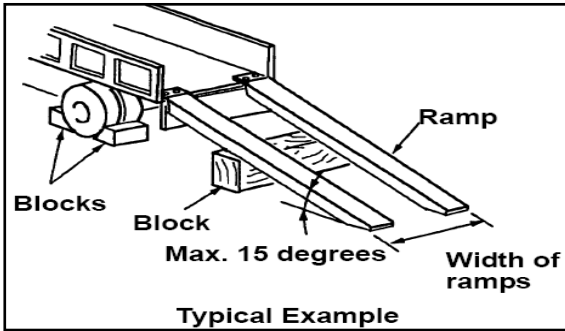

CAUTION

- The machine must be loaded on solid level ground, to keep a safe distance with the edge of the road.
- Using an inclined plane or loading dock, placed a good block under the wheels.
- Inclined surface must have a sufficient width. Make sure that the inclination of the slope is less than 15 degrees.
- The loading and unloading station must have sufficient width and strength to support the machine, and have a slope less than 15 degrees.
- In cold weather, be sure to preheat the machine before loading or unloading.

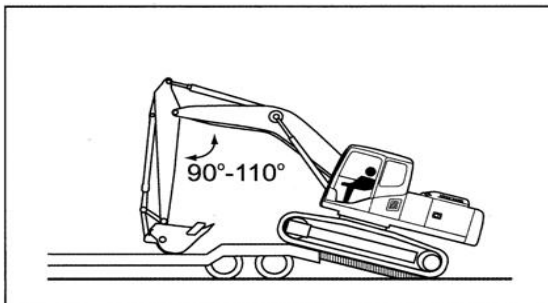

Loading should abide by the following rules:

(a) The direction of the machine:

- With working device: the working device should be placed on the front walk.

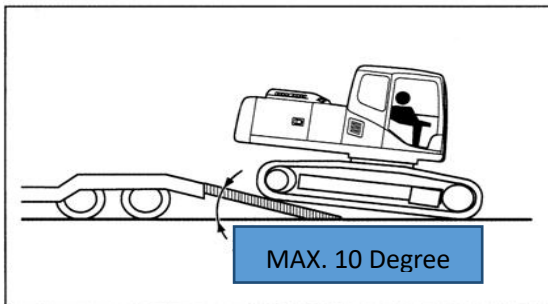

- Without working device: walking backwards as shown in the figure .

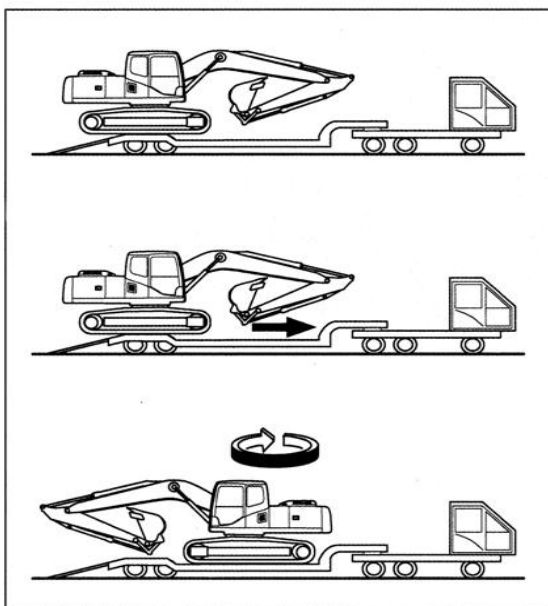

(b) Machine line should be corresponded with the trailer line.

(c) Slowly moving the machine onto the slope.
With a working device: supporting the flat surface of the bucket on the trailer, the angle of the arm and boom should be in the range of 90 to 110 degrees.

(d) When the machine is just getting started to go on the trailer tilting plate, the bucket support on the trailer. Walking slowly toward the front until the track all open on the trailer and securely touching on the plate so far.

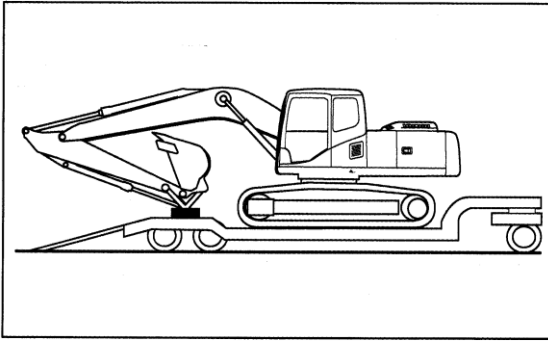

- (e) Slightly lift the bucket, revenue the stick and keep it at the bottom ,slowly rotate 180 degrees on the machine.
- (f) Extend the bucket and arm cylinders fully , then fall the boom slowly.
- (g) To prevent damage during the bucket cylinder transported ,wood mat pad should be mat at one end of the bucket cylinder to prevent it touching the backplane.
- (h) Stop the engine, remove the key from the switch.

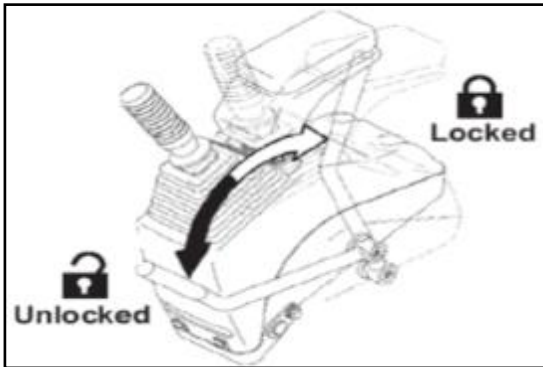

- (i) Operate the contorl rod several times until the pressure in the hydraulic cylinder is fully released
- (j) Pull the pilot control switch lever to the locked position.
- (k) Close the window of the cabin, ventilation skylights and doors, hood exhaust port to prevent wind and rain from entering.

4-10-2. Transportation

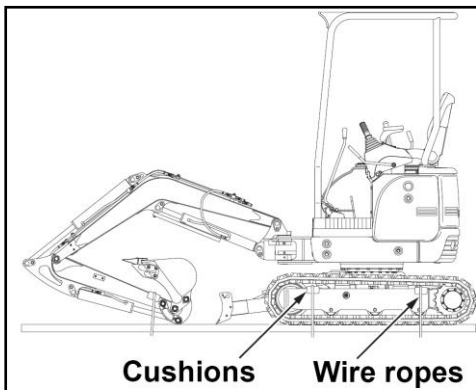

- (a) Place the pad in the front and rear of the track.
- (b) Place pads under the track to prevent movement of the machine during transport. Use suitable strength chains or rope to fastern the machine.
- (c) Pay particular attention to the machine firmly fixed, so that it does not pull to one side.



Tie the chain or rope on the frame of the machine, do not make the chain or rope across or pressure in the hydraulic lines or hoses.

4-10-3. Unloading

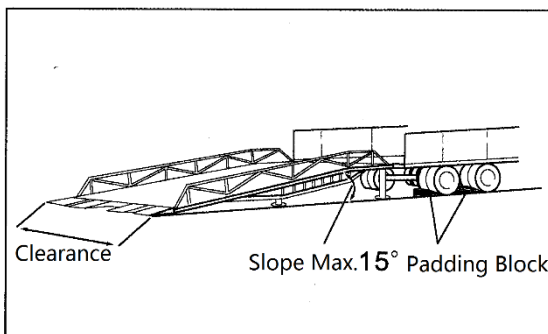

- (A) The machine must be loaded and unloaded on solid level ground, to keep a safe distance with the edge of the road.
- (B) Trailer brake is applied appropriately, and put the pad in the tire decentralized to ensure that the trailer does not move.Then installed ramp between the trailer and machine.To ensure that both sides of the ramp in the same horizontal plane. The slope of the ramp does not exceed 15 °. The distance between the ramp is adjusted to match

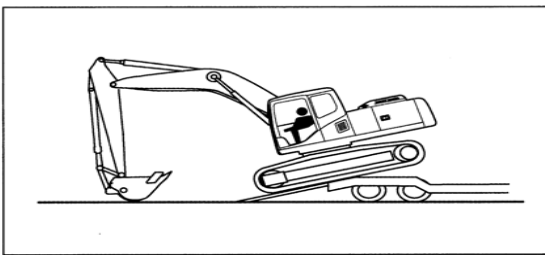
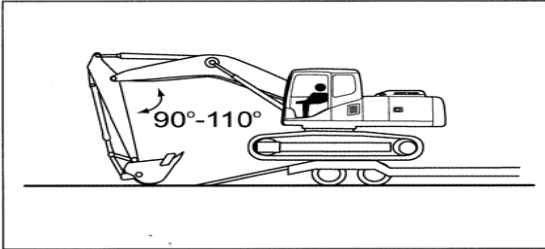
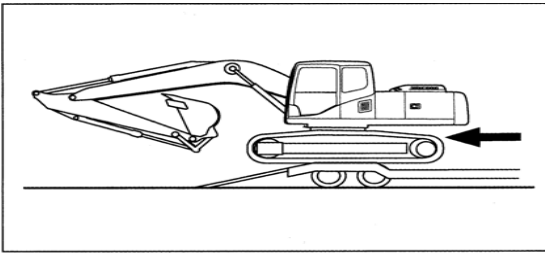

- with the center of the crawler.
- (C) Remove the fixed machine chain or rope.
- (D) Start engine
- (E) Safety lock lever transferred to the free position.
- (F) Raise the working device, and make the Stick received to the boom , then slowly move the machine.
- (G) Move the machine to the rear of the trailer,toward the ramp, then stop moving the machine.
- (H) Adjust the angle of the arm and boom to 90 ~ 110 degrees, support the the bucket flat surface on the ground, and then slowly move the machine onto the ramp.
- (I) When the machine is moved to the ramp, slow operate the boom and arm, and carefully lower into the machine until it clears the ramp.

CAUTION

- Phase of the back of the trailer tablet with beveled into a protuberance, be careful to pass through.
- To prevent the damage of the work equipment. Please always maintain a 90-degree angle between the arm and boom when unloaded. Income Stick may cause damage to the machine when unloaded.
- To prevent possible damage of hydraulic cylinder. Do not let the machine bucket in violent collision with the ground.

4-10-4. Machine lifting methods

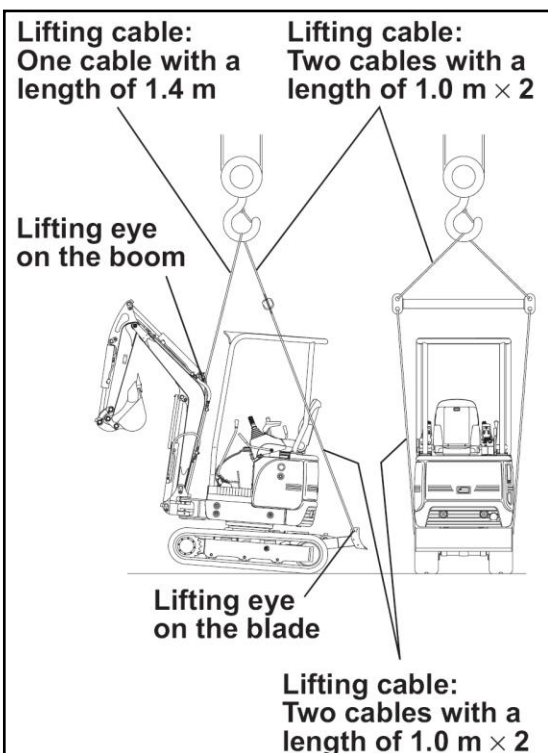

Lifting methods:

- (A) Extend the arm and bucket hydraulic cylinder fully. Lower the boom until the bucket touch the ground.
- (B) Pull the Pilot control switch lever to the locked position.
- (C) Turn off the engine, remove the key from the key switch.
- (D) Using long enough rope and supporting rod so that they do not collide with the machine in the lifting. According to the need ,enlacing some protection material in the cable and support rod,so as to avoid damage.
- (E) Drive the crane to the appropriate position for lifting.
- (F) As shown, the rope pass through both sides of the track frame . Install the cabinle to the crane.
- (G) Please use the lifting equipment above 3T and the

 **CAUTION**

- Lifting wire rope and other lifting tools may be broken, resulted in injuries. Do not use damaged or aging cabin or lifting tools.
- Regarding the correct lifting method, the type, size of lifting wire rope and lifting tools, is sure to contact your service dealer of CARTER.
- Pull the Pilot control switch lever to the locked position, so that the machine will not move accidentally when lifted.
- Incorrect lifting, incorrect cabin installation will cause the movement of the machine when lifted, resulting in machine damage, personal injury.
- Do not lift the machine quickly. Otherwise, the lifting wire rope and lifting tools will load excessively, may cause the fracture.
- Nobody should close to or come to the bottom of the lifting machine.

Chapter 5. Maintenance

5-1. Maintenance Guide

Do not carry out any inspection and maintenance which are not described in this manual.

5-1-1. Time meter

Check hour meter readings every day to see whether it is time to carry out maintenance.

5-1-2. Carter genuine quick-wear parts

To use Carter genuine parts prescribed in the manual as replacement parts.

5-1-3. Carter genuine lubricating oil

To use Carter genuine engine oil and grease. According to the environmental temperature, select the oil and grease with appropriate viscosity.

5-1-4. Windshield washer fluid

Use windshield washer fluid and make sure not to let the dirty thing enter.

5-1-5. Pure engine lurricating oil

To use clean oil and grease. And to keep the oil or grease containers clean and free from contamination .

5-1-6. Check the emission oil and used filter

After changing oil or replacing the filter, to check whether there are impurities and metal shavings in old oil and filter. If you find a large number of metal shavings and impurities, please report to relative specilist and take appropriate measures.

5-1-7. Fuel pre-filter

If the machine is equipped with a primary fuel filter, when refueling, do not remove it.

5-1-8. Welding instruction

- (A) Turn off the engine start switch.
- (B) Disconnect the negative pole of battery.
- (C) The voltage should not be more than 200V continuously.
- (D) Connecting the grounding cable in less than 1m away from the welding area. If the grounding cable is near the instrument cable, connectors, equipments will in failure.
- (E) Avoid the seal and bearing between welded area and the ground.
- (F) Don't take working devices pings or hydraulic cylinder as the ground

5-1-9. Avoid to drop things into machine interior

- (A) When open the inspection window or the tank nozzle check, be careful not to let nuts, bolts or tools fall inside the machine. If these things fall into the machine, it can cause damage and malfunction of the machine and cause an accident. If something falls into the machine, be sure to take out it immediately.
- (B) Don't take any unnecessary thing in your pocket, just take things you need.

5-1-10. Dusty working place

Please do the following steps in dusty working area:

- (A) once the air filter clogging alarm in air filter makes alarm, please clean when the filter element in a timely manner.
- (B) cleaning frequently radiator core to avoid blocking.
- (C) frequently cleaning and replacing of fuel filters.
- (D) clean electrical components, especially the starter motor and alternator in order to avoid the accumulation of dust.
- (E) When the inspection or oil change, it is necessary to move the machine where there is no dust to prevent dust from entering the oil.

5-1-11. Avoid mixing lubricating oil

Do not mix different grades of oil. If you need to add a different grades, to drain the old oil completely, replace it with a new oil.

5-1-12. Installation of Hydraulic hose

- (A) When disassembling the parts with O-ring or gasket seal, it is necessary to clean the mounting surface and replace with new parts. Do not forget to install the O-rings and gaskets.
- (B) When installing the hose, the hose should not be bent or twisted into a small diameter circle. This will damage the hose and significantly shorten the life of the hose.

5-1-13. Check after checking and maintenance

If you do not double check after inspection and maintenance, unexpected failures may occur, leading to serious injury or damage. Be sure to do the following steps.

- (A) Check after the working (engine off).
- (B) Did you forget to check and maintain?
- (C) it has properly performed all inspections and maintenance items?
- (D) Is there a tool or parts falling inside the machine? If the parts are inside the machine and then fall into the transmission mechanism, it is very dangerous.
- (E) Are there any water or oil leakage? Are all the bolts are tightened?
- (F) check the engine operation.
- (G) Regarding to check the engine operation, see "When the engine is running, the maintenance need two people for maintenance" and pay attention to safety.
- (H) inspection and maintenance items are in working order?
- (I) engine speed increases, and when a load is applied to the oil pressure, oil leaks or not?

5-2. Normal Maintenance and Inspection

Learn how to properly maintain the machine. Follow proper maintenance and inspection procedures described in this manual.

Daily pre-start checks:



- (A) Check the controller and the instrument.
- (B) Check the cooling water, fuel and oil level.
- (C) Check hoses and piping leaks, kinks, wear and tear.
- (D) Walk around the machine, check the general phenomenon of the machine, noise, heat, etc. for mobile inspection.
- (E) Check the slack or missing parts.
- (F) if the machine has a problem, to repair or contact Carter local dealer or Carter local serviceman before the machine works.

⚠ IMPORTANT

- Only use recommended fuel and lubricants.
- Only use Carter genuine parts.
- If you do not use the recommended fuel, lubricants and Carter genuine parts , the machine will lose the warranty right from Carter.
- Do not adjust the engine speed-controller or hydraulic system relief valve.
- Prevent steam and water contacting electrical components.
- Do not disassemble as the main controller, sensors and other electronic components.

5-2-1. Check time meter usually

- (A) Do regular maintenance according to and with the help of time meter.
- (B) Regular maintenance intervals on the table is based on normal operating conditions. When operating the machine in harsh conditions, the interval should be shortened for maintenance.
- (C) Periodic lubrication, maintenance, inspection and adjustment.

5-2-2. Use the right fuel and lubricant

⚠ IMPORTANT

Always use the recommended fuel and lubricants. Otherwise, it will damage the machine and cause the loss of Carter's product maintenance warranty.

5-2-3. Preparation work before maintenance

Prior to the following maintenance work, the machine parks as following, unless otherwise in specified position.



- Machine parked on flat ground.
- Low the bucket to the ground.
- Put the throttle control knob at 1 stage.
- Let the engine running at low idling speed for 5 minutes.
- The key switch is in off and remove the key. (If it is necessary that the engine must be running when carrying out maintenance, be sure there must be person there.).

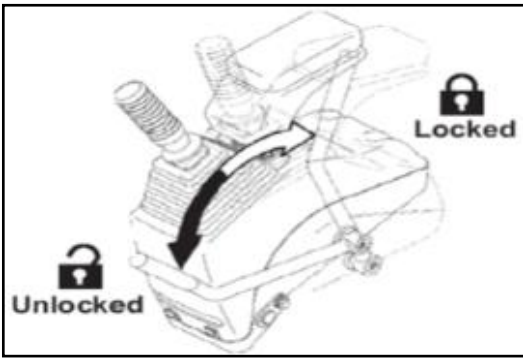

- The switch lever to lock position.



- Before the machine for maintenance work, to hang signs "prohibit operation" onto the right lever.

5-2-4. Periodic replacement of parts

To ensure safe operation, ensure regular inspection of the machine. In addition, if these parts have a problem, it will cause serious safety hazards and potentially cause a fire. It is very difficult to estimate the wear of these parts, the aging or the degree of strength reduction by visual inspection. Therefore, general speaking, do replacement of the parts in the following table as replacement intervals shown. However, if parts found any problems during inspection, be sure to do replacement before the start of the operation, and do not consider the normal replacement interval.

Periodic replacement of parts			Replacement time
Engine		Fuel hose (from fuel tank to filter)	Two years or 4000hours, whichever comes first.
		Fuel hose(from filter to engine)	
		Engine oil (from filter to engine)	
Hydraulic system	Main machine	Rubber hose for oil suction	
		Pump output hose	
		Oil return hose	
		Pilot hose	
	Working devices	Arm cylinder hose	
		Boom cylinder hose	
Bucket cylinder hose			

CAUTION

Ensure that the replacement hose, but also to replace the O-ring seals and gaskets.

While replacing hoses, check the deformation, cracks or damage of the connector, replace if necessary.

Ensure all hoses regularly inspection and replace any defective parts or re-tightening if need.

Ask your dealer or service personnel of Carter for the correct replacement method.

5-2-5. Check and tighten the track shoe's bolt

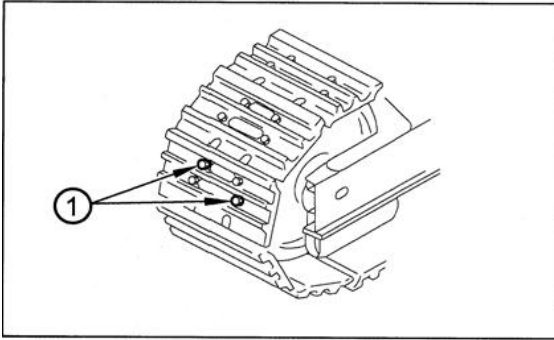

If the machine still work when track shoe bolt ① looses, so it is necessary to tighten the bolt immediately.

1. Tighten method

(A) Track shoes

- Tighten the bolt to $392 \pm 19.6N \cdot m$ ($40 \pm 2kgf \cdot m$) tightening torque, then check whether the nut and track shoe have tight contact with track chain shackle.
- After the inspection, then tighten 90° with $\pm 10^\circ$.

2. Tighten Order

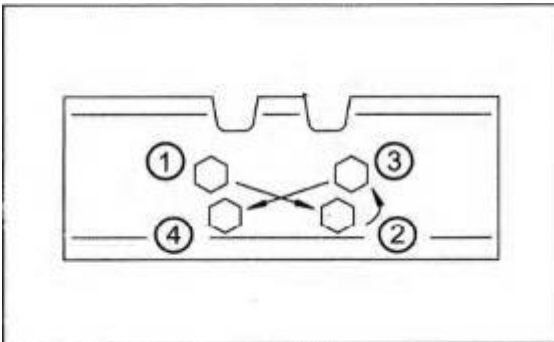

As shown on the left, tighten bolts. After tightening, check whether the nut and track shoe have tight contact with track chain shackle.

5-3. Maintenance Sechedule

Carter Excavator Maintenance Sechedule											
No.	Model	Checking Item	Part Name	Unit	Qty.	Maintenance intervals (H)					
						10	50	250	500	1000	2000
1	CT16/18Perkins and Laidong Series	Engine oil	Engine oil	L	4	V	F	G			
2		Engine oil	Engine oil element	Piece	1		F	G			
3		Fuel filter	Fuel filter element	Piece	1			G			
4		Oil-water seperator	element	Piece	1	V			G		
5		Air filter	Main element	Piece	1			V	G		
6		Air filter	Safety element	Piece	1				G		
7		Radiator	Coolant	L	7.5	V					G
8		Hydraulic suction filter	suction filter element	Piece	1					G	
9		Hydraulic return oil filter	return oil filter element	Piece	1					G	
10		Pilot filter	Pilot filter element	Piece	0						
11		Hydraulic oil	Hydraulic oil	L	35						G
12		Travelling motor	Gear oil	L	1.5			F		G	
13	CT16/18Yanmar Series	Engine oil	Engine oil	L	4	V	F	G			
14		Engine oil	Engine oil element	Piece	1		F	G			
15		Fuel filter	Fuel filterelement	Piece	1			G			
16		Oil-water seperator	element	Piece	1	V			G		
17		Air filter	Main element	Piece	1			V	G		
18		Air filter	Safety element	Piece	1				G		
19		Radiator	Coolant	L	7.5	V					G
20		Hydraulic suction filter	suction filter element	Piece	1					G	
21		Hydraulic return oil filter	return oil filter element	Piece	1					G	
22		Pilot filter	Pilot filter element	Piece	0					G	
23		Hydraulic oil	Hydraulic oil	L	35						G
24		Travelling motor	Gear oil	L	1.5						

V: Check、 Maintenance and clean; F Initial replacement; G: Replacement

Notes:

1. If excavators do crushing jobs, hydraulic filter replacement time is 500 hours / times, hydraulic oil replacement time of 1000 hours / times;
2. When the working area is higher than 3,000 meters above sea level, antifreeze replacement cycle shortened to 1000 hours.
3. When the working area is higher than 3,000 meters above sea level , engine oil and filter replacement cycle should be shorten, when t 4,000 meters, the replacement cycle shortened to

125 hours.

5-4. Maintenance Period

10 hours / every day maintenance

● Grease the pin of bulldozer blade	● Grease the pins of connecting rod of boom and arm
● Grease the pins of arm, boom cylinder	● Check engine oil lever
● Check hydraulic oil lever in tank	● Check the leakage of hydraulic system
● Check fuel oil lever	● Check Oil-water separator
● Check the leakage of fuel system	● Check oil lever of reducer
● Check cooling system and fill coolant	● Clean radiator
● Check wear-and-tear condition of Bucket teeth and side teeth	● Check the wear-and-tear condition of engine fan belt
● Check the seat belt	● Check the broken and welding snap in bucket etc structural parts.
● Check all the switches	● Check all exterior lights, speakers, monitor and control indicator lights.
● Start the engine and check its start-up performance, check the exhausting vent air color is standard or not, and check the noise of the engine.	● Check the tension of track, make sure no looseness, noise and damage
● Check all the controls	● Check looseness of bolts or nuts

50 hours/every week maintenance

● 10 hours a day or do all maintenance checks	● Grease into rollaway nest of the swing bearing
● Check the fuel tank vent valve	● Replace the engine oil and oil filter
● Check the battery fluid and charging volume	● Cleaning the fuel tank filler screen

250 hours/every month maintenance

● Every 10 hours or every day and every 50 hours Maintenance	● Check Swing Walking Gearbox oil level
● Replacing engine oil and filter	● Clean air filter external filter element
● Check Walking Gearbox oil level	● Check wear and tear condition of the front working devices pin and bushing
● Check wear and tear condition and air leakage of the fuel system piping.	● Replacing fuel filters

500 hours/3 months maintenance

<ul style="list-style-type: none"> ● Every 10 hours / day, every 50 hours and every 250 hours maintenance 	<ul style="list-style-type: none"> ● Clean oil-water separator filter
<ul style="list-style-type: none"> ● Replace the air filter element 	<ul style="list-style-type: none"> ● Clean radiator
<ul style="list-style-type: none"> ● Checking grease volume in swing bearing 	<ul style="list-style-type: none"> ●

1000 hours/6 months maintenance

<ul style="list-style-type: none"> ● Every 10 hours / day, every 50 hours and every 250 hours, 500 hours maintenance 	<ul style="list-style-type: none"> ● Replace walking reducer oil
<ul style="list-style-type: none"> ● Check air conditioner coolant 	<ul style="list-style-type: none"> ● Replace hydraulic suction filter
<ul style="list-style-type: none"> ● Replace hydraulic return oil filter 	
<ul style="list-style-type: none"> ● Clean fuel pump filter 	

2000 hours/ 12 months maintenance

<ul style="list-style-type: none"> ● Every 10 hours / day, every 50 hours and every 250 hours, 500 hours, 1000hours maintenance 	<ul style="list-style-type: none"> ● Replace radiator coolant
<ul style="list-style-type: none"> ● Check electric generator and starting motor 	<ul style="list-style-type: none"> ● Check engine shock damper
<ul style="list-style-type: none"> ● Check the broken and welding snap in structural parts. 	<ul style="list-style-type: none"> ● Replace hydraulic oil

5-4-1. 10 hours/every day maintenance

1. Greasing pins of bulldozer balde, boom,arm and working devices.

Grease every 10 hours or once a day

2. Check the engine oil level

Check the engine oil level



In order to obtain the correct reading, every day before starting the engine to check the oil level, be sure to stop the machine at flat ground.

(A) Take out the dipstick, clean it with a clean cloth to wipe the grease on the dipstick, reinsert the dipstick.

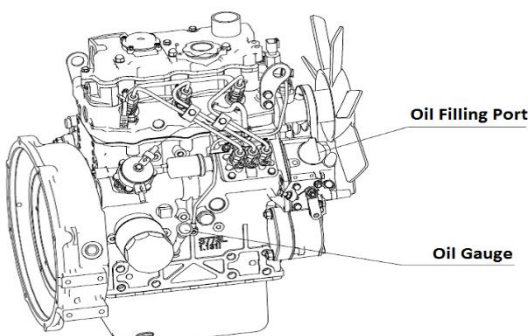

Maintenance-Maintenance Period

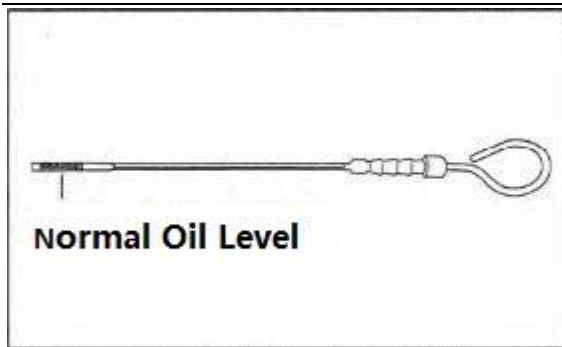

- (B) Take out the dipstick, the oil level must be between the marks in the score line
- (C) If necessary, fill the fuel. Be sure to use only recommended oil.
- (D) If the oil level is higher than the mark, the oil must be drained to its proper position

CAUTION

Check the oil level immediately after the shutdown, it will produce incorrect number, make sure to check the oil after at least 10 minutes of rest time.

3. Check hydraulic oil level

CAUTION

- Prohibit to start engine when there is no hydraulic oil in the tank.
- Hydraulic tank is under pressure. To be slowly unscrew the tank lid. After the pressure was released, carefully open the lid and refuel.

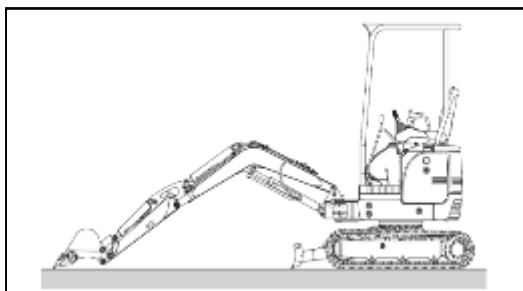

- (A) Park the machine on flat ground.
- (B) Retract the arm cylinder and bucket cylinder fully to locate the machine.

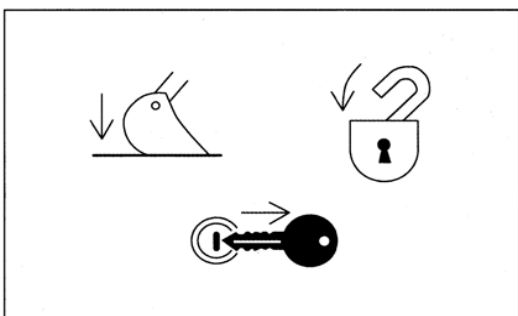

- (C) Lower the bucket to the ground.
- (D) Put the throttle lever down to the lowest position.
- (E) Running the engine in idling speed for 5 minutes.
- (F) Stop the engine and take away the key.

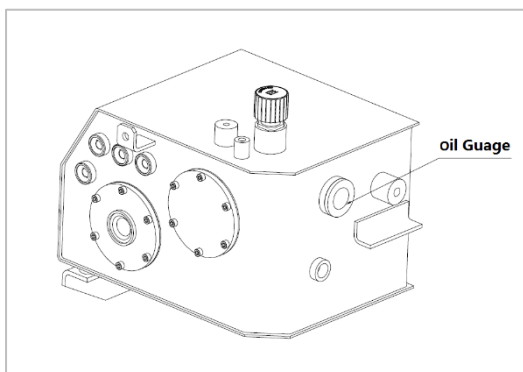

- (G) The pilot control lever is pulled to lock position.
- (H) After opening the hood, check the oil level gauge on the hydraulic tank. The oil level must be between the oil level mark, if need, please refuel the oil.

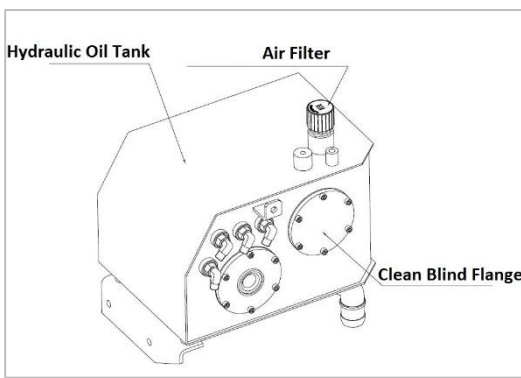

- (I) Slowly unscrew the preload air filter, release the pressure.
- (J) Refuel. And check the oil level gauge again
- (K) Tighten the air filter.

4. Check the hydraulic system leak

After daily work, check to make sure there is no leakage of hose, tubes, cylinders, motors, etc., and if any, make sure to do maintenance timely.

5. Check the fuel level

CAUTION

- Carefully treat fuel
 - Before refueling, turn off the engine.
 - When refuelling and fueling system is under working condition, smoking is prohibited.
 - Prevent all impurities, dust, water or other particles into fuel system.
- Park the machine on flat ground.
 - Low the bucket to the ground.
 - Put the throttle lever down to the lowest position.
 - Run the engine in idling speed for 5 minutes
 - Turn off the engine.
 - The pilot control lever is pulled to lock position.
 - Check the fuel gauge on the disc. If necessary, refuel. .
 - When the fuel tank to ensure that no fuel spilled on the machine, not to exceed a predetermined amount. When the amount of fuel over the fuel tank filter, stop refueling. Be sure to secure the muzzle of fuel to avoid damage to the fuel tank muzzle oil filter.
 - Put the fuel filler cap back onto the fuel filler. Always lock fuel cap to prevent loss or damage.

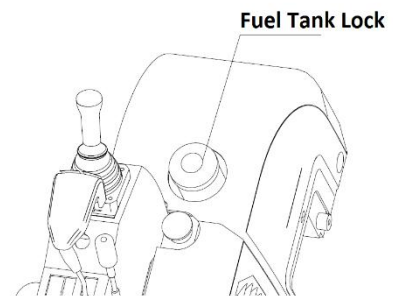

CAUTION

Precautions for automatic refueling apparatus:

- 1) When refueling, never forget to open the oil filler cap.
- 2) To prevent excessive fuel, immediately stop refueling when oil exceed the filter of tank.

6. Check the oil-water separator

- (A) Oil-water separator can separate water and impurities from oil.
There is floating body in the separator. When the water in it is full enough, the floating body will float. Please discharge water.
- (B) Discharge steps:

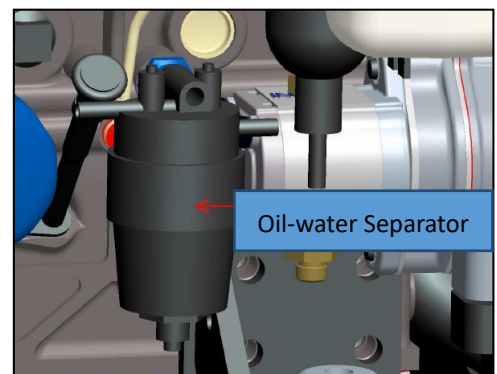

- Release the rotary knob under the separator to discharge water.
After discharging, tighten the knob to prevent oil and air leakage.

CAUTION

Please manually release discharge knob, and do not use wrench to avoid damaging the drainage screw.

7. Check the fuel system leak

Each filter and fuel piping system should be checked to ensure that the fuel system is not leaking, if there is leakage, find the cause and repair immediately.

8. Check the cooling system

CAUTION

Before releasing the upper lid of radiator, be sure to the engine fully cools down, then slowly unscrew the lid. Before removing the lid, the pressure in radiator should be released. Do not remove the radiator cover if not necessary, to check the coolant level in the reserve tank.

- (A) When the engine is cold, remove the radiator cover to check the coolant level, do not just check the level in the reserve tank.
- (B) Check the antifreeze pipe is unobstructed, confirming there is no clogging. Check the antifreeze and piping leaks or not. If there is leakage phenomenon, find the reason and do maintenance.
- (C) The engine is cold when checking whether the level of the reserve tank located between "FULL" and "MINIMUM". If blow "MINIMUM", filling antifreeze to "MINIMUM".

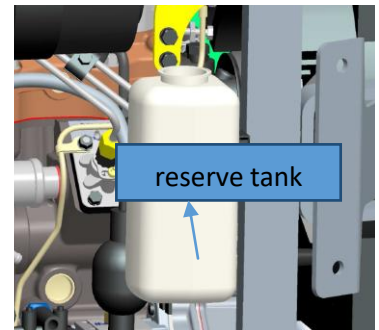

9. Cleaning Radiator

If the excavator works in dusty environment, please timely clean leaves and impurities from radiator.

10. Check all the switches

Check all switches condition before starting.

11. Check wear-and-tear condition of Bucket teeth and side teeth

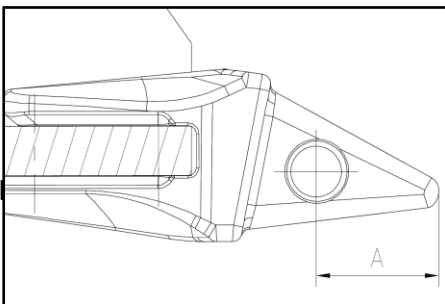

- (A) Check the wear-and-tear, looseness of bucket teeth

- Check the bucket teeth wear and looseness.

If the degree of wear of bucket teeth than shown below.

Size of A (mm)

Model of excavator	New	Use limit
CT16-9D/CT16-9B	44	25
CT18-9D/CT18-6L	44	25

CAUTION

Prevent injury due to flying metal pieces, wearing protective goggles or safety glasses or other proper safety devices.

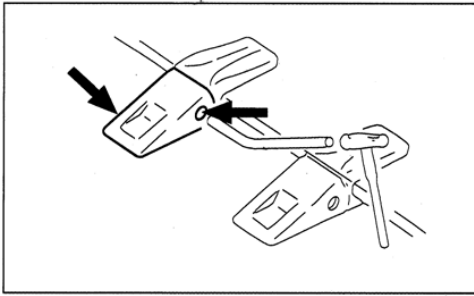

(B) Replacement Procedure

- Use mace and punches remove the locking pin out.

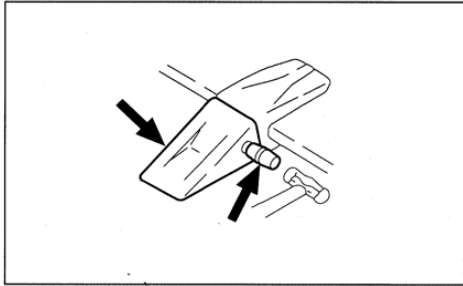

- Dismantle the teeth, check the lock pin is damaged. If necessary, replace it. We must use new products to replace the pin and bucket teeth.

12. Check the wear-and-tear condition of engine fan belt

Check and adjust the fan belt tension

IMPORTANT

Slack fan belt may cause insufficient battery charging, engine overheating and rapid abnormal speed cause belt wear. However, two tight belts and straps can cause bearing damage.

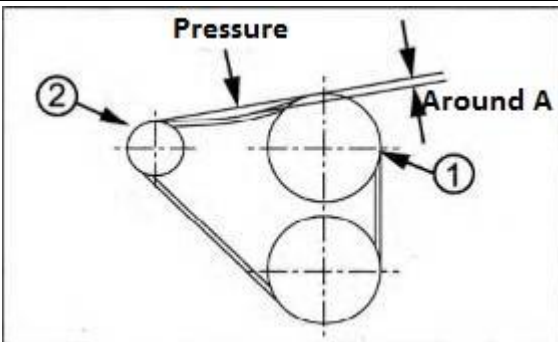

- (A) Visually inspect the wear condition of the belt. If you need to replace. Thumb pressure midpoint between the fan pulley ① and ② AC motor pulley belt to check the fan belt tension. When pressed pressure of approximately 98N (10kgf), the falls of 8-12 mm belt is ok. If not, adjust the belt if necessary.

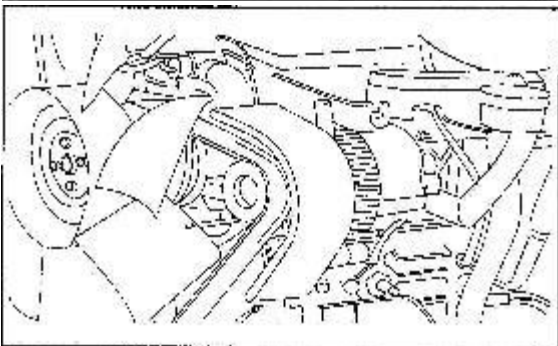

- (B) If the tension is not within, the adjustment plate and loosen the bracket bolts. Adjust the belt tension bolts degree of disturbance within the A range. Tighten the adjustment bolt and the bracket plate.
- (C) Check the engine belt for wear or broken connections, if the above situation, replace the belt.

CAUTION

Install the new belt, ensure the running the engine running at low idling speed 3-5 minutes, and then adjust the tension to ensure the new belt correctly seated.

13. Check the seat belt

14. Check the broken and welding snap in bucket etc structural parts.

Check and lubricate machine daily, checking whether the structure and welding seam is broken, if necessary, make sure to repair or replace it before machine works.

15. Check the tension of the track

- Check daily all parts of the track is lost or not, damaged or wear and tear, if any, timely repair or replacement are necessary.
- Check the tightness of track to meet the requirements.

16. Check all exterior lights, speakers, monitor and control indicator lights.

The engine switch to "ON", check each indicator and observe whether the instrument is working properly, check the speaker and external work lights and monitors whether there is a fault in it, if fault or damage, repaired or replacement are needed.

17. Start the engine and check its start-up performance, check the exhausting vent air color is standard or not, and check the noise of the engine.

18. Check all the control

- 1) Start the machine, check the engine control lever at a certain speed.
- 2) Moving slowly at first working device, so that the line of hydraulic oil can heat up, otherwise it will damage the hydraulic cylinders and hydraulic motors.
- 3) Record slow motion or malfunctions, find the cause and repair.

19. Check looseness of bolts or nuts

5-4-2. 50 hours/every week maintenance

1. 10 hours a day or do all maintenance checks

2. Grease into rollaway nest of the swing bearing

Use grease gun put the grease the swing bearing two or three time, then swing the unper carriage twice, each 120 degree rotation to lubricate the bearings.

3. Check the fuel tank vent valve

Open the drain valve at the bottom of the fuel tank, remove the water and debris.

4. Replace the engine oil and oil filter

50 hours after the initial operation, replace the engine oil and oil filter, as for the replacement methods, please refer to 250 hours maintenance requirements.

5. Check the battery fluid and charging volume

6. Cleaning the fuel tank filler screen

Open the fuel tank lock, remove the filter and clean

5-4-3. 250 hours/every month maintenance

1. Every 10 hours or every day and every 50 hours Maintenance

2. Replacing fuel filters

For the safety and protection of the environment, please use appropriate containers to take the discharged fuel. The fuel must not fall to the ground, ditch, or poured into rivers, ponds or lakes. Properly handle the waste of fuel.

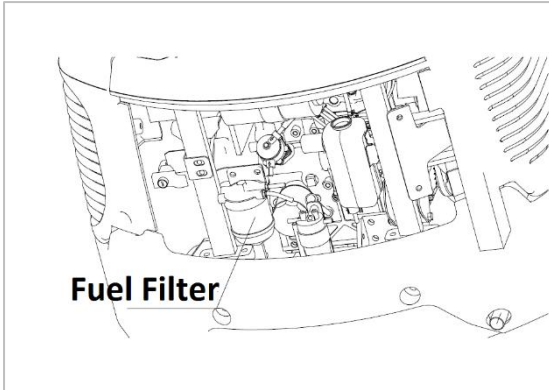

- (A) Remove the fuel fine filter by unscrew the upper bolt with a wrench to remove the intermediate filter element.
- (B) Put thin coat of clean oil onto the new filter element.
- (C) Install the new filter to the original position, tighten the bolts (not over tighten).
- (D) After replacing the filter, exhaust air from the fuel system.

3. Replacement engine oil and oil filter

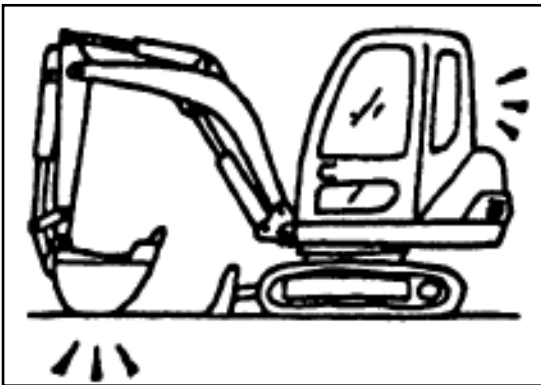

Replace the engine oil filter element - every 250 hours

- (A) Start the engine to warm the oil, but do not overheat.
- (B) Park the machine on flat ground
- (C) Low the bucket to the ground
- (D) Put the throttle lever down to the lowest position.
- (E) Running the engine in idling speed for 5 minutes.
- (F) Stop the engine and take away the key.

Note: When the working area is higher than 3,000 meters above sea level , engine oil and filter replacement cycle should be shorten, when 4,000 meters, the replacement cycle shortened to 125 hours.

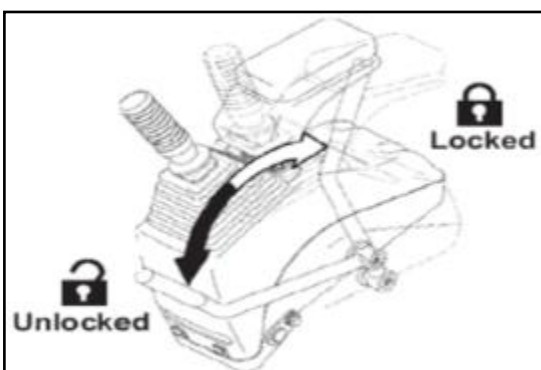

- (G) The pilot control lever is pulled to lock position

CAUTION

Perhaps the engine is very hot, be careful not to be burn.

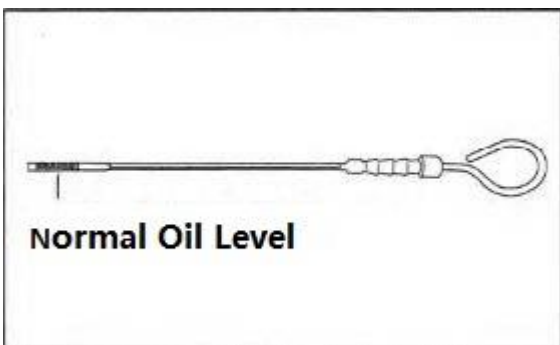
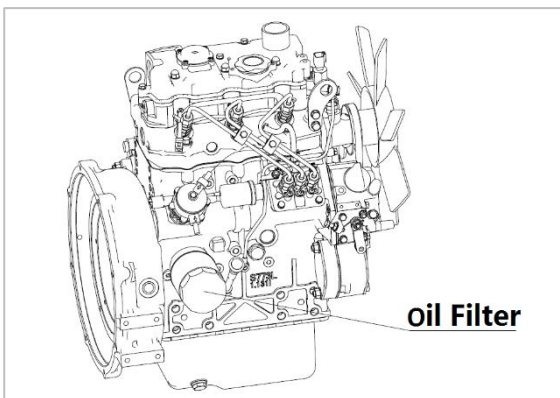
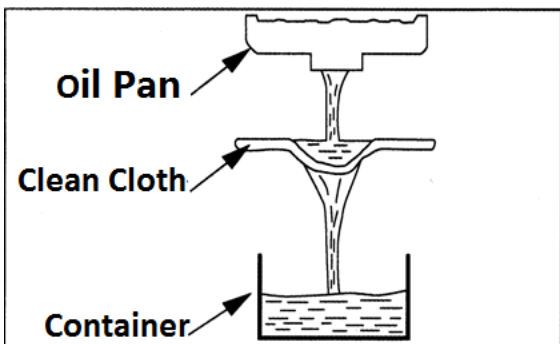
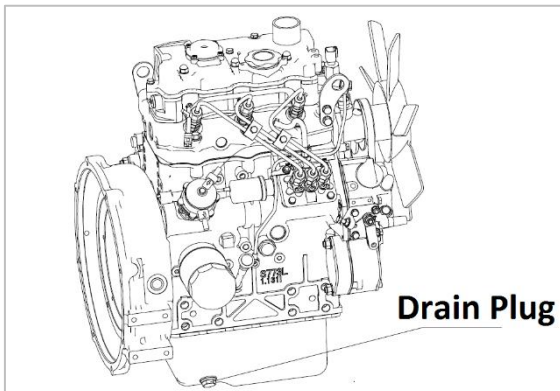

- (H) Remove the drain plug and let the oil flow into the 5L container through a clean cloth.
- (I) After discharge of oil, check whether there are metal chips and other foreign matter left on the cloth or not.
- (J) Mount it on and tighten the drain plug.
- (K) With a strap wrench counter-clockwise twist remove the engine oil filter cylinder.
- (L) Clean the contact surface of filter gasket to engine.
- (M) Put thin coat of clean oil onto the new filter element.
- (N) Install the new filter. Screw manually clockwise until the cartridge filter gasket contact to the contact surface. When installing the filter, make sure that does not damage the gasket.
- (O) Tighten engine oil filter with strap wrench more than 3/4 to 1 cycle.
- (P) Open the oil filler cap, oil the engine with recommended oil. After 15 minutes, check the oil level between marks in the oil dipstick.
- (Q) Mount the cap.
- (R) Start the engine, run the engine without load at low speed for 5 minutes.
- (S) Check the engine oil pressure monitor disk is off. If not, turn off the engine immediately and find the cause.
- (T) Turn off the engine. The key switch off and take the

key away.

- (U) Check the drain plug if there are any leaks.
- (V) Check the oil level on the dipstick

4. Clean air filter external filter element

Note: If the indicator shows on, you must clean the air filter.

Note: When clean the filter element three time, it should be replaced.

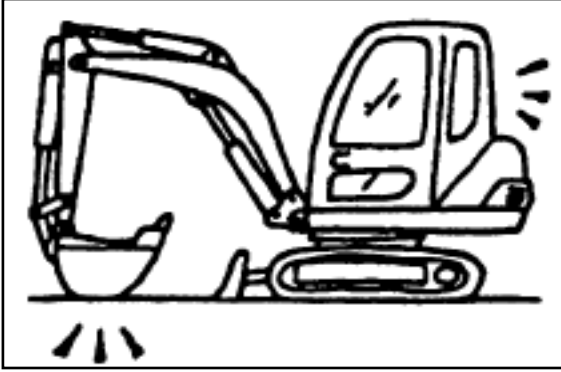

- (A) Park the machine on flat ground
- (B) Low the bucket to the ground
- (C) Put the throttle lever down to the lowest position.
- (D) Runing the engine in idling speed for 5 minutes.
- (E) Stop the engine and take away the key.

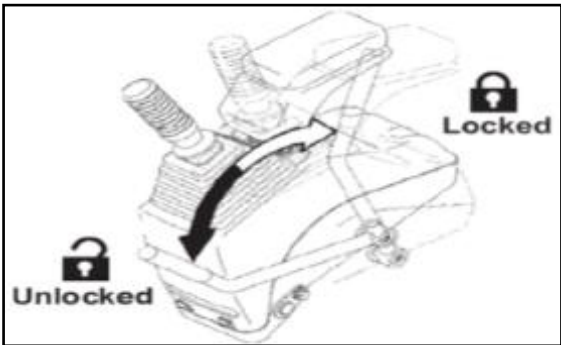

- (F) The pilot control lever is pulled to lock position.

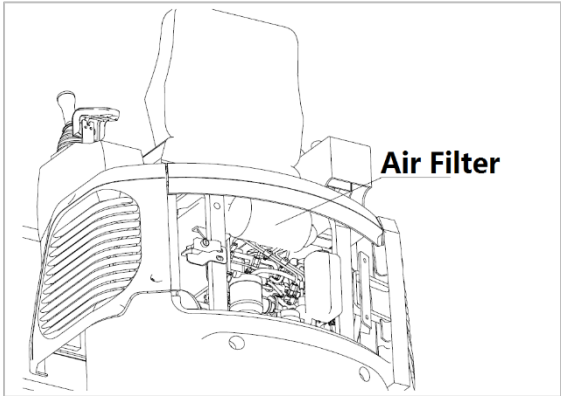

- (G) Open the cover of the retaining tabs and remove the cover.
- (H) Gently shake out air filter external filter. Be careful not to come up with an internal filter. Gently pat the outer filter, don't hit it against hard objects.

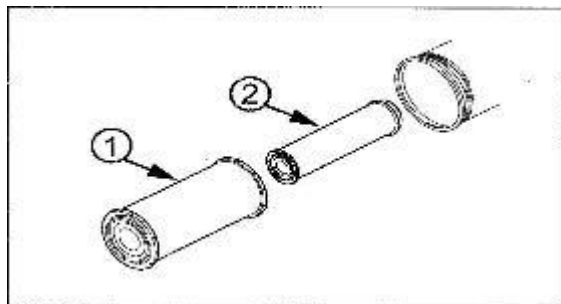

- (I) Blow air out filter from inside to outside.
- (J) Before Blow air external filter, clean the filter inside.

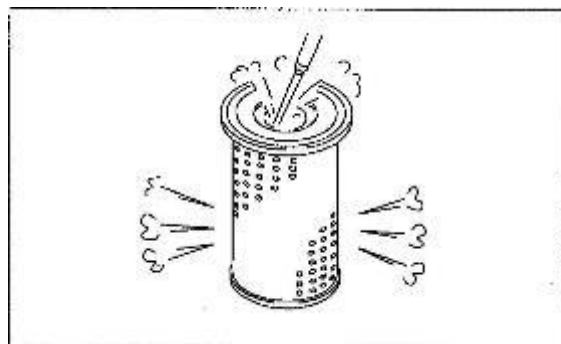

- (K) Mount the external filter back.
- (L) Mount on the cover and dust discharge port and fasten the cover.
- (M) Start the machine at low speed and empty loading

running.

- (N) Check the indicator light and alarm, if abnormal, immediately stop the engine. And check the reason, if the filter has the problem, replace the external filter.

When replacing the air filter element, external and internal filter ① ② two filter replace together. Before removing the external filter ①, clean the filter inside. Remove the internal cartridge ② replacement. When installing, first fitted on the internal filter ②, then attach the external filter.

CAUTION

When the engine is running, you can not move or clean air filter. If you use compressed air to clean the parts, take appropriate eye protection measures.

5. Check Walking Gearbox oil level

CAUTION

Keep the body and face away from the air and release plug. Gear oil is hot, Be sure to wait until after the gear oil cooling, then slowly loosen the air release plug to release the pressure.

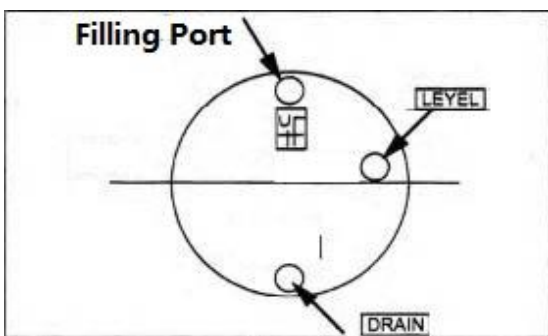
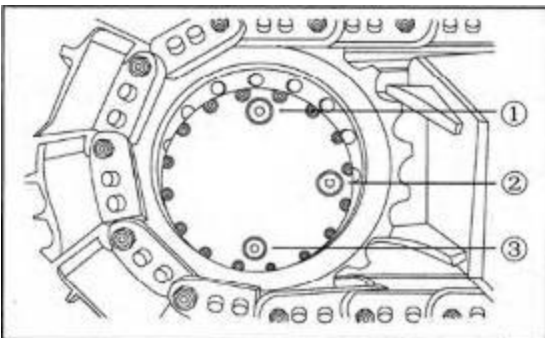
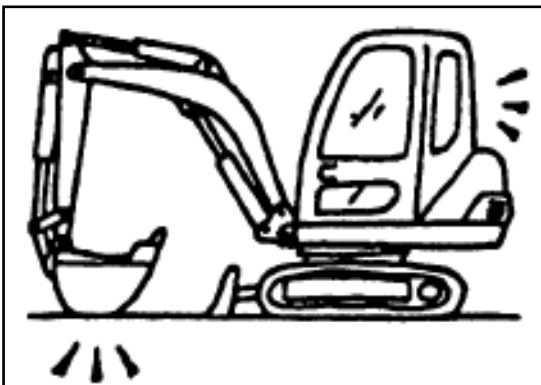

- Park the machine on the flat ground.
- Rotate travelling motor until the connection line of plug ① and plug ③ is in the vertical position.
- Low the bucket to the ground.
- Put the throttle lever down to the lowest position.
- Runing the engine in idling speed for 5 minutes.
- Stop the engine and take away the key.
- The pilot lever pulled to lock position. Stay 10 minutes and check the oil level.
- After gear oil cooling, slowly loosen the air release plug ① to release the pressure.
- Remove the air release plug ① and oil level check plug ②, the oil must go to the bottom of the hole.
- If necessary, fill the oil over the oil level plug

hole. (See gear oil table)

- Sealing tape wrapped threaded plug, plug ① and ② load, tighten the drain plug ① and ② to 9 ~ 12N.m.
- Check the gear oil level of another walking reduction gear.

6. Check wear and tear condition of the front working devices pin and bushing

7. Check wear and tear condition and air leakage of the fuel system piping.

5-4-4. 500 hours/3 months maintenance

1. Every 10 hours / day, every 50 hours and every 250 hours maintenance

2. Clean oil-water separator filter

For the safety and protection of the environment, please use appropriate containers to take the discharged fuel. The fuel must not fall to the ground, ditch, or poured into rivers, ponds or lakes. Properly handle the waste of fuel.

- Remove the fuel fine filter by unscrewing the upper bolt with a wrench to remove the intermediate filter element.
- Put thin coat of clean oil onto the new filter element.
- After mounting the filter element, rotate oil-water separator filter bowl until the gasket sealing surface encountered so far.
- Using filter wrench, rotate approximately 2/3 cycle more and tighten the cartridge filter. But do not over tighten.
- After replacing the filter, exhaust air from the fuel system.

3. Replace the air filter element

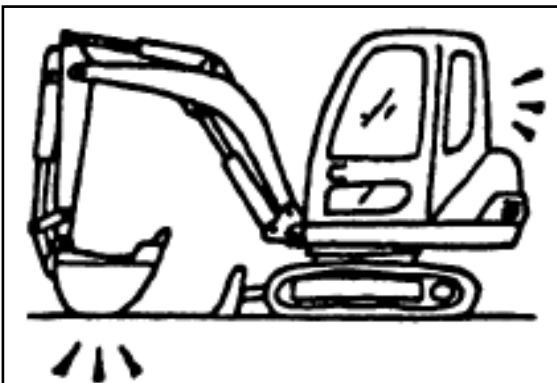

- Park the machine on flat ground.
- Low the bucket to the ground.
- Put the throttle lever down to the lowest position.
- Run the engine in idling speed for 5 minutes.
- Stop the engine and take away the key.

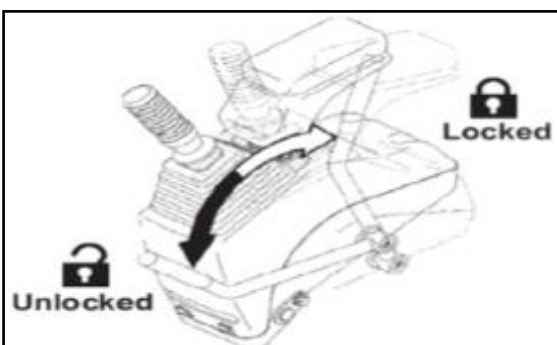

- Lock the equipment control by shifting the safety device lever to the lock position.

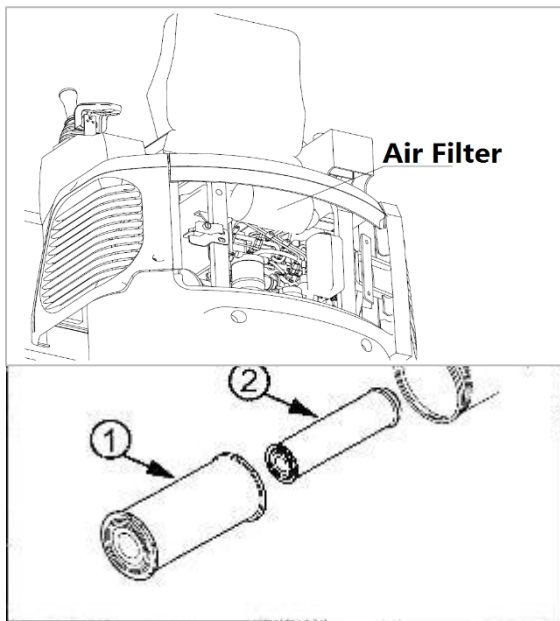

- (G) Loosen the cover snaps, remove the cover
- (H) Gently shake the air filter and take it out.
- (I) Replace both inner filter ② and outer air filter ①. Clean up the pre-filter before remove the outer air filter ①. Remove the inner filter ② and replace. When install, install inner filter ② firstly, then outer filter ① and cover snaps.
- (J) Start the machine with low speed and no-load operating.
- (K) lights and alarm, immediately stop the engine if abnormal. Check the reason.

4. Clean up radiator

CAUTION

- Clean up by compressed air with low press less than 0.2MPa(2kgf/cm²). The working staff walked away, be careful of the flying debris, and wear personal protective equipment, including eye protection equipment.
- When working in dusty environments, check if have dirt and clogging on net cover, if yes, clean up and install.

CAUTION

To prevent damage of the fins, maintain an appropriate distance when using compressed air. Damaged fins may cause leaks or overheating. In the dusty field, check the heat sink daily, unlimited by maintenance cycle.

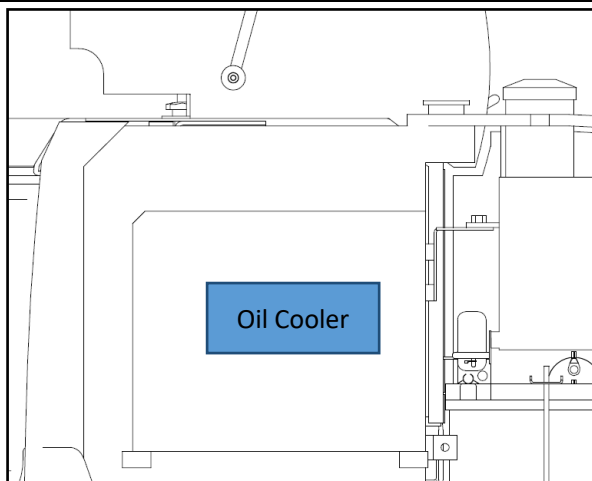

- (A) Open the radiator access door and cover.
- (B) Remove dirt, dust or leaves clogged on oil cooler and heat sink sheet. Meantime, clean the grille in front of oil cooler
- (C) Remove the grille in front of radiator and clean
- (D) Clean up the radiator and oil cooler by using compressed air with low press less than 0.2MPa (2kgf/cm²) or water.
- (E) Rubber hoses. If the hose has cracks or due to aging

has hardening, replace with a new hose. Also, check if the hose clamp has loose.

5. Check the amount of butter inside the slewing ring gear

Check the amount of butter and if has metamorphism though the butter observation hole,if has etamorphism,replace it.

5-4-5. 1000 hours/6 months maintence 1000

1. Do Per 10h/day、 Per 50h、 Per 250h、 Per 500h maintence

2. Replace Walking Gearbox oil



Keep the body and face away from the air release plug. Gear oil is hot, must wait until the gear oil cooling,only slowly loosen the air release plug to release the pressure.

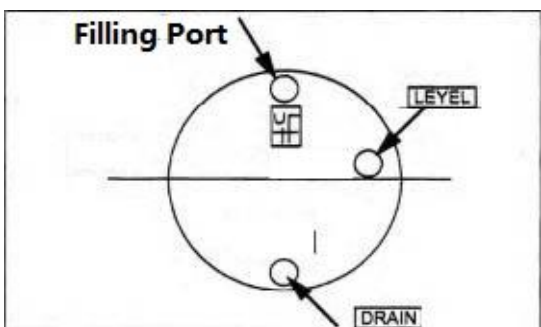
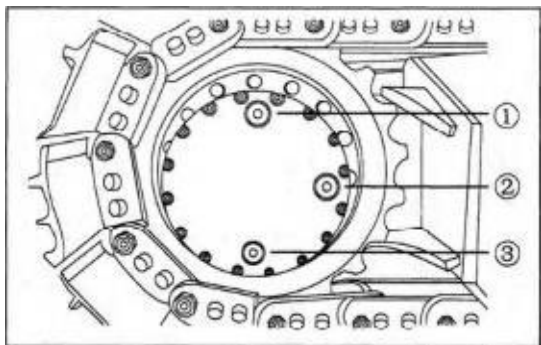
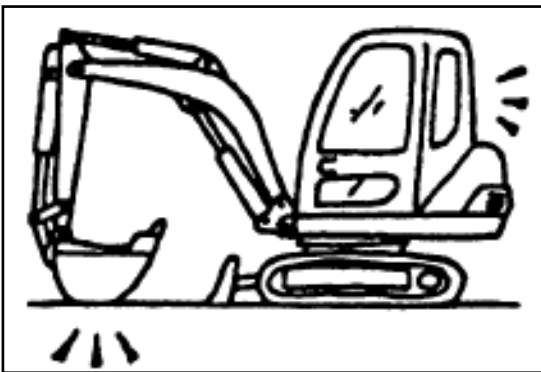

- Parking machine on ground level.
- Rotary travel motor, until the vertical position until the plug ② and plug ③ connection in the vertical position.
- Put the bucket on the ground.
- Lower the throttle control knob gear to the first gear.
- No-load operating the engine 5 minutes with no-load speed to idle speed.
- Stop the engine, and pull out keys.
- Pull the pilot control knob to the locked position
- Slowly open the plug ① to release pressure after the gear oil cooling.
- Prepare a 4L container, and remove the drain plug ③, and Discharge oil.
- Clean up the drain plug,and install plug ③,tighten the plug to 9~12N·m
- Remove oil level and check pulg②.

- Refuel to the Oil overflows level and check the plug hole.
- Clean and install plug ① and ②, install plug and tighten the plug to 9~12N·m.
- Repeat the 8-13 steps to the other travel reducer equipment.

3. Replace Hydraulic suction oil filter

CAUTION

- Hydraulic oil may hot, Starting work until the oil coolig.
- Hydraulic tank is under pressure. To be slowly unscrew the tank lid after the pressure was released, carefully open the lid.
- It would damage the pump If you start the engine when the hydraulic pump has no oil.

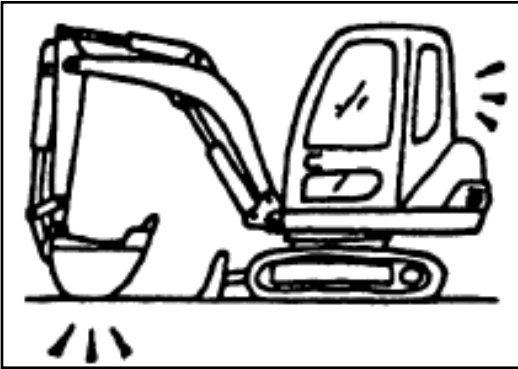

(A) Parking machine on ground.

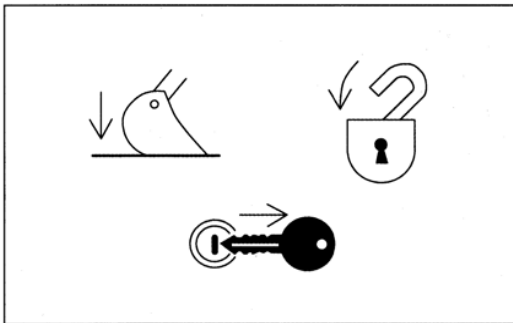

(B) Put the bucket on the ground.

(C) Lower the throttle control knob gear to the first gear.

(D) No-load operating the engine 5 minutes with no-load speed to idle speed.

(E) Stop the engine, and pull out keys.

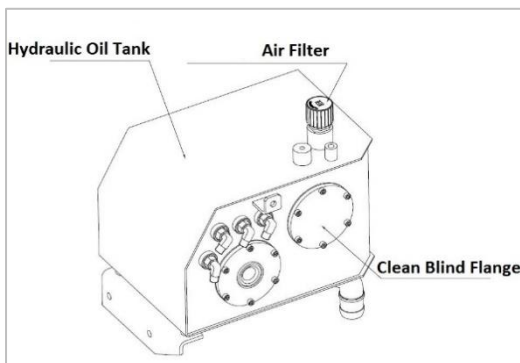

(F) Pull the pilot control knob to the locked position.

(G) Clean up the top and side of hydraulic tank

(H) Slowly loose the air filter and release pressure.

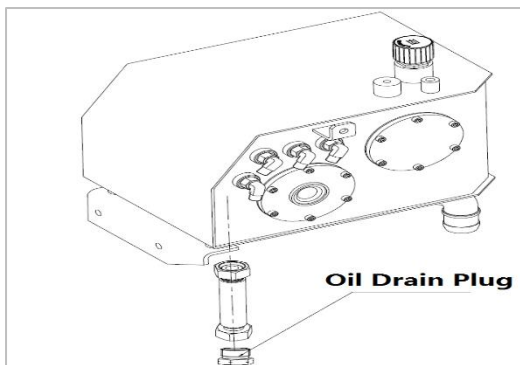

(I) Unscrew and remove the bottom of the hydraulic tank drain hose plug, discharge the hydraulic oil tank.

(J) Remove and clean the flange cover.

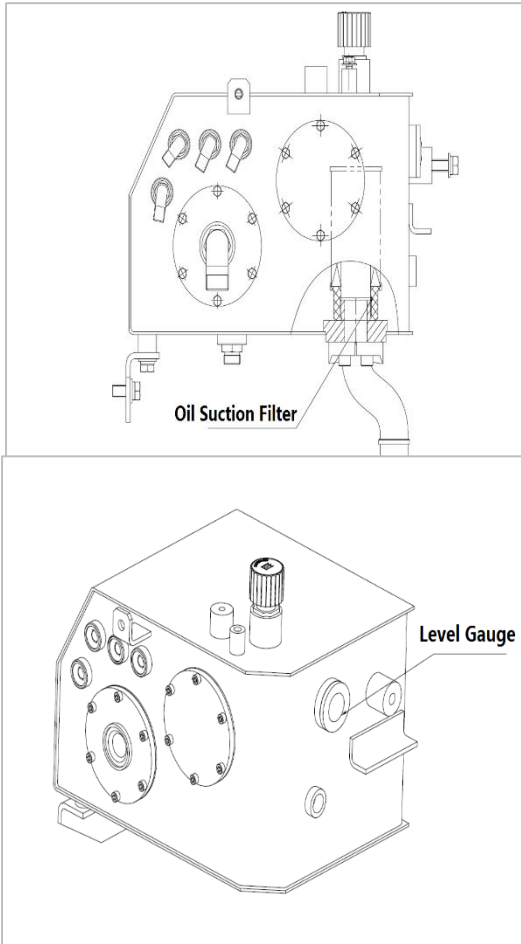

- (K) Put hands into Cleaning flanged mouth and take out suction oil filter
- (L) Clean up the filter and inner of tank. If replace new suction filter,install it to thread position and tighten by hands.
- (M) Clean and install the bottom of the hydraulic tank drain hose plug.
- (N) Install the cleanding flange cover,and tighten to 9~12N·m.
- (O) Fill in oil though pre-air filter installation mouth,until reach to the oil level gauge.
- (P) Screw the pre-air filer by hands.
- (Q) No load engine with low-speed,and slowly and smoothly operating the control level,to remove the air in the hydraulic system.Notes: Pilot circuit is provided with exhaust devices. Therefore, after the completion of this operating step, exclude the air in the pilot circuit.
- (R) Positioning machine by arm cylinder and bucket cylinder fully retracted state.
- (S) Put the bucket on the ground
- (T) Lower the throttle control knob gear to the first gear.
- (U) No-load operating the engine 5 minutes with no-load speed to idle speed.
- (V) Stop the engine, and pull out keys.
- (W) Pull the pilot contrl knob to the locked position
- (X) Check the hdydraulic tank oil level. If necessary, open the pre-air filter to fill oil.

4. Replace Hydraulic return oil filter

CAUTION

Hydraulic tank is under pressure. To be slowly unscrew the tank lid after the pressure was released, carefully open the lid



- (A) Parking machine on ground.
- (B) Put the bucket on the ground
- (C) Lower the throttle control knob gear to the first gear.
- (D) No-load operating the engine 5 minutes with no-load speed to idle speed.
- (E) Stop the engine, and pull out keys.

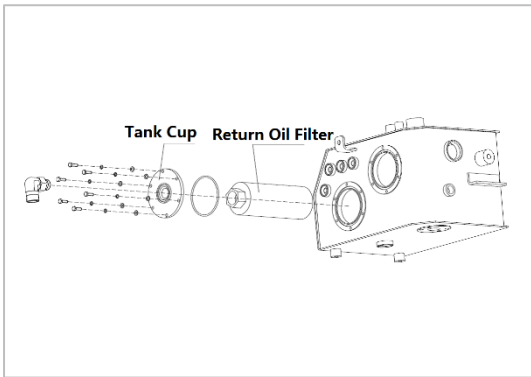

- (F) Pull the pilot control knob to the locked position
- (G) Slowly loose the air filter and release pressure.
- (H) Unscrew and remove the bottom of the hydraulic tank drain hose plug, discharge the hydraulic oil tank.
- (I) Open and take out the bottom of the hydraulic tank drain hose plug, and discharge the hydraulic oil.
- (J) Open and take out tank cover and take out return oil filter, and then screw new filter.
- (K) Install tank cover, and screw the bolts to 9~12N·m
- (L) Fill in oil through pre-air filter installation mouth, until reach to the oil level gauge.
- (M) Screw the pre-air filter by hands

CAUTION

Take out filter, and check if there is metal particles and debris. Excess particles of bronze and steel, said hydraulic pumps, motors, valves damaged or will be damaged. Class rubber debris, said hydraulic cylinder seal damage.

5. Clean up Fuel injection pump filter

Removal the connector from the bottom of the fuel pump, clean and install the filter on the connector.

5-4-6. 2000 hours/every year maintenance

1. 10h/every day、 per 50h、 per 250h、 per 500h、 per 2000h maintenance

2. Replace radiator antifreeze

Clean up the Inner of radiator—replace antifreeze

CAUTION

When delivery from Carter, water and Carter designated long-life coolant mixture has filled in the cooling system. Even if use the Carter designated long-life coolant, replace the coolant every year or 2000h, whichever comes first. When working in 3000h field, replace the coolant every 1000h.

CAUTION

Do not open the radiator cover before the engine cooling. Slowly open the cover, release the whole pressure before remove the cover.

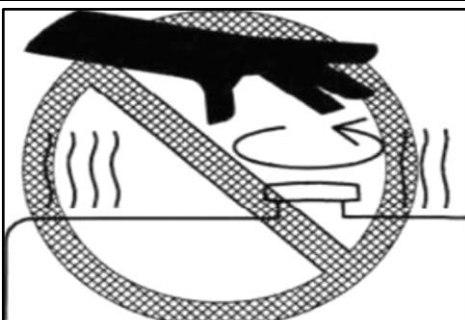

- (A) Remove the radiator cover, and open the drain switch in the bottom of radiator, and discharge coolant ①.
- (B) Close the drain switch ①. Fill water and radiator cleaner into radiator. Start the engine and slightly higher than the low idle speed. When the thermometer pointer reaches the green zone,

continue to run the engine for about fifteen minutes.

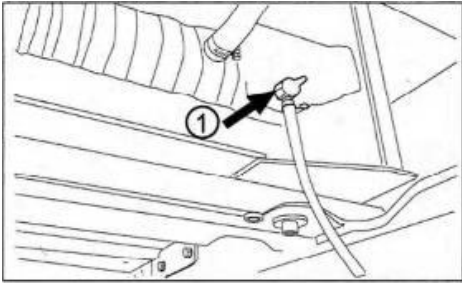

- (C) Stop the engine and open the radiator drain switch ①, wash cooling system by water, until the drained water is clean. This helps to remove rust and sediment.
- (D) Close drain switch ①, Put the mixing ratio coolant and rust inhibitors or anti-freeze agents into radiator. Slowly add coolant to prevent air bubbles mixed into the system.
- (E) Start engine and fully discharge the cooling air in the cooling system.
- (F) Keep the engine running for several minutes after fill in coolant. Check the coolant level, fill in coolant if necessary.

3. Check generator and starter motor

4. Check the engine damper

5. Check welding parts, if there are cracks or open welding, etc.

6. Replacement the hydraulic oil

CAUTION

- Hydraulic oil may hot, Starting work until the oil coolig.
- Hydraulic tank is under pressure. To be slowly unscrew the tank lid after the pressure was released, carefully open the lid.
- It would damage the pump if you start the engine when the hydraulic pump has no oil.

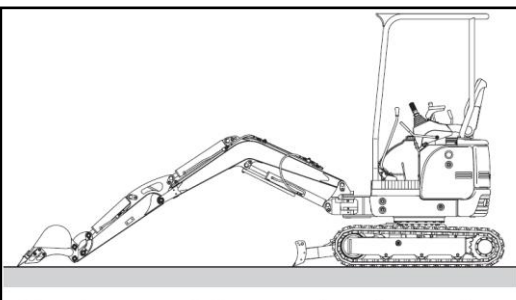

- (A) Parking machine on the ground.
- (B) Positioning machine by arm cylinder and bucket cylinder fully retracted state

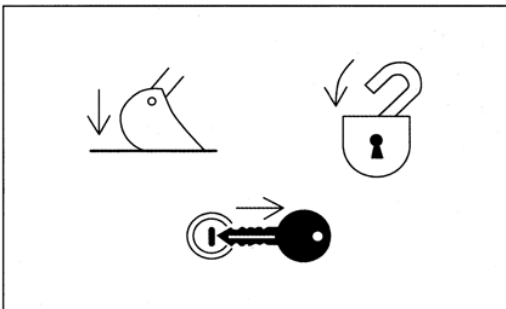

- (C) Put the bucket on the ground.
- (D) Lower the throttle control knob gear to the first gear.
- (E) No-load operating the engine 5 minutes with no-load speed to idle speed.
- (F) Stop the engine, and pull out keys.

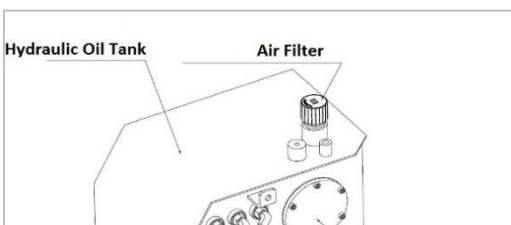

Maintenance-Maintenance Period

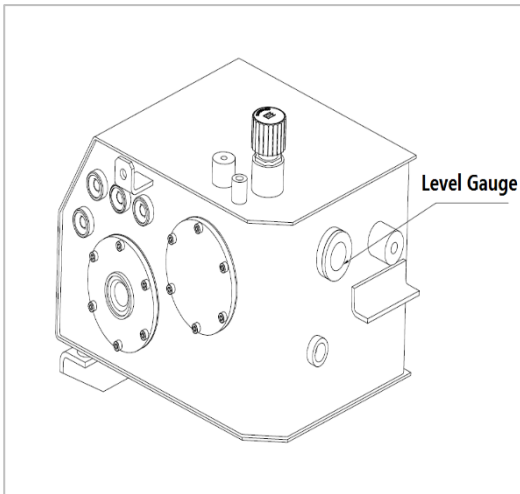

- (G) Pull the pilot control knob to the locked position
- (H) Slowly loose the air filter and release pressure.
- (I) Unscrew and remove the bottom of the hydraulic tank drain hose plug, discharge the hydraulic oil tank.
- (J) Open and take out the bottom of the hydraulic tank drain hose plug, and discharge the hydraulic oil.
- (K) Take out suction filter and Hanging rod assembly ②.
- (L) Put hands into Cleaning flanged mouth and take out suction oil filter.
- (M) Clean up the filter and inner of tank. If replace new suction filter, install it to thread position and tighten by hands.

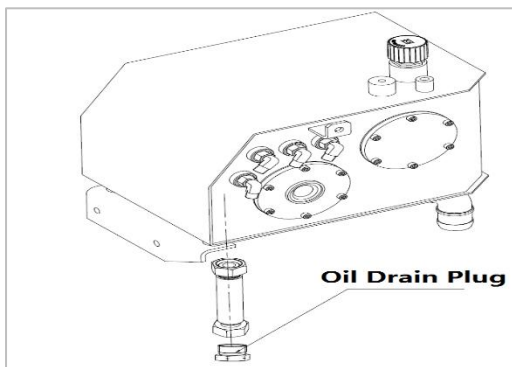

- (N) Clean and install the bottom of the hydraulic tank drain hose plug.
- (O) Install the cleaning flange cover, and tighten to 9~12N·m.
- (P) Fill in oil through pre-air filter installation mouth, until reach to the oil level gauge.
- (Q) Screw the pre-air filter by hands.
- (R) No load engine with low-speed, and slowly and smoothly operating the control level, to remove the air in the hydraulic system. Notes: Pilot circuit is provided with exhaust devices. Therefore, after the completion of this operating step, exclude the air in the pilot circuit.

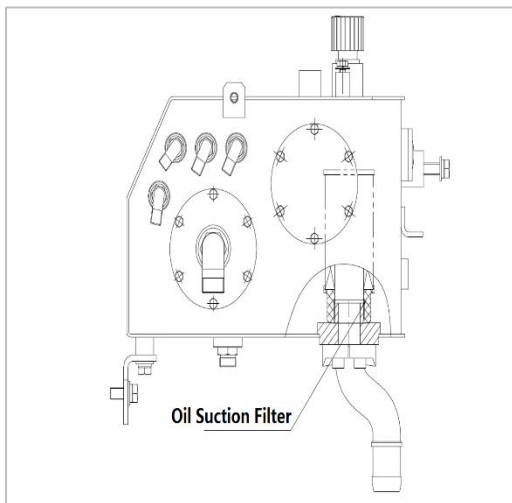

- (S) Positioning machine by arm cylinder and bucket cylinder fully retracted state..
- (T) Put the bucket on the ground.
- (U) Lower the throttle control knob gear to the first gear..
- (V) Stop the engine, and take out keys.
- (W) Pull the pilot control knob to the locked position.
- (X) Check hydraulic oil level. Open the air filter and fill in hydraulic oil if necessary.

5-5. Electrical System

⚠ IMPORTANT

- Improper installation of radio communications equipment and accessories will affect the unexpected movement and influenced to electronic components of the machine. Improper installation of electrical devices may also cause the machine malfunction, fire. When you install radio communication device, additional electrical components or replace electrical components, be sure to ask the dealer or Carter service offices.
- Never attempt to disassemble or modify the electrical and electronic components. If you need to replace or retrofit these parts, contact with dealer or Carter service office.

5-5-1. Battery

⚠ CAUTION

- Battery gas can cause an explosion. Sparks and flames should far away from the battery. With a flashlight to check the electrolyte level. "GS" brand batteries Carter which excavators used is maintenance-free batteries, no need to add any water and electrolyte.
- Sulfuric acid inside the battery electrolyte is toxic. It has very strong acid, can burn the skin, make clothes hole. If splashed into the eyes, it will cause blindness.



(A) Take the following methods to avoid dangerous:

- Filled batteries in a well-ventilated place.
- Wear rubber gloves and eye protection equipment.
- Beware of electrolyte spillage and dripping.
- Use the appropriate sub-battery start-up procedure.

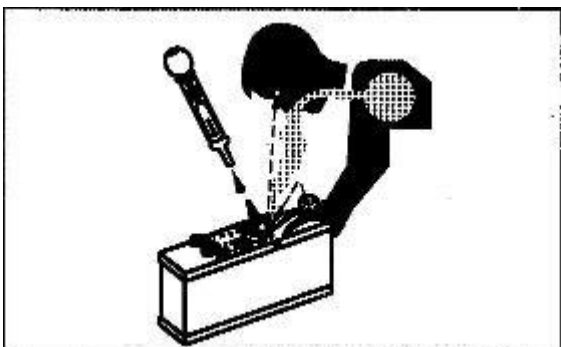

(B) If spilled acid:

- On the skin, rinsed with water 10 to 15 minutes.
- Use baking soda or lime to neutralize the acid.
- In the eyes, rinsed with water 10 to 15 minutes.
- All cases should be immediately go to the hospital treatment.

(C) If swallow the acid:

- Drink more water and milk.
- Then drink magnesia emulsion, the stirred egg or vegetable oil.
- Immediately go to hospital.

1. Check the battery electrolyte level and terminal

⚠ CAUTION

- Always the first disengaged grounded (-) battery clip, and finally installed.
- Keep the terminal on the top of battery and the bleed hole clean, in order to avoid battery discharge. Check the corrosion and relaxation of batter terminal. Coated with vaseline to the terminals to avoid corrosion.

2. Check the specific gravity of the electrolyte

⚠ CAUTION

- Battery gas can cause an explosion. Sparks and flames should far away from the battery. With a flashlight to check the electrolyte level.
- Sulfuric acid inside the battery electrolyte is toxic. It has very strong acid, can burn the skin, make clothes hole. If splashed into the eyes, it will cause blindness.
- Not available metal was placed horizontally in the terminal way to check the battery. Use pressure gauge or hydrometer.
- Always the first disengaged grounded (-) battery clip, and finally installed.

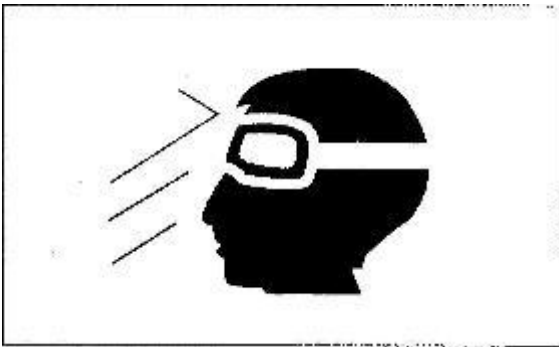

(a) Take the following ways to avoid danger:

- Filling the battery in a well ventilated place
- Wear eye protection tools and plastic gloves
- When adding electrolyte, avoid smoke inhalation.
- Beware of the electrolyte splashing and dripping.

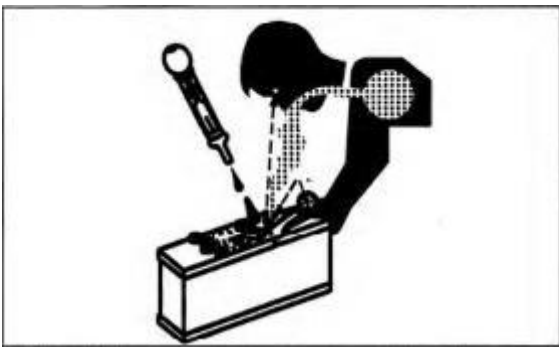

(b) If the acid is spilled :

- If on the skin, rinse with water for 10 to 15 minutes.
- Use sodium bicarbonate or lime to neutralize acid.
- If in the eyes, rinse the eyes with water for 10 to 15 minutes.
- All cases should be treated immediately to the hospital.

(c) if the acid is swallowed:

- Drink plenty of water or milk.
- Then drink the beaten egg, magnesia emulsion or vegetable oil.
- And immediately to the hospital for

treatment.

3. Battery removal and installation

After the battery in place, check if the battery is moving or not. If move, re-install

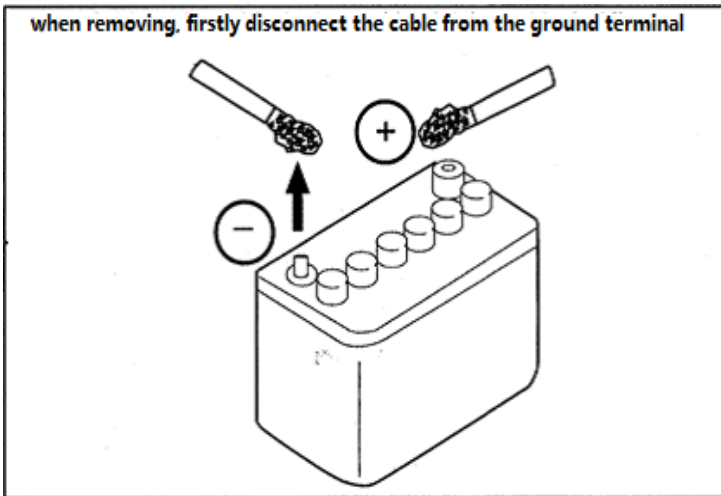

- (A) When removing, firstly remove from the ground side (the negative (-) terminal). Avoid using any tools to touch with ground in the positive (+) terminal.
- (B) When installing the battery, and finally to connect the terminal to the ground side.

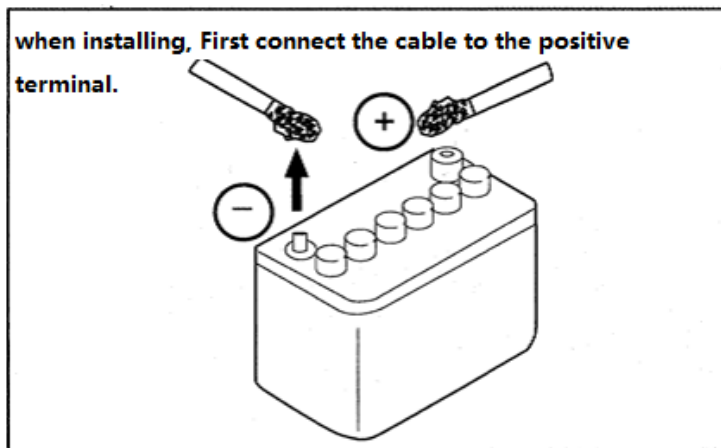

- (C) mounting bolt tightening torque: :
9.8~14.7N·m(7.2~10.8lb·ft)

4. Replace battery

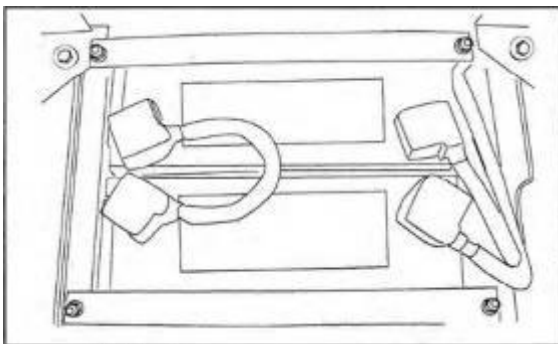

A negative (-) ground 12 volt battery.

5. Replace the fuse

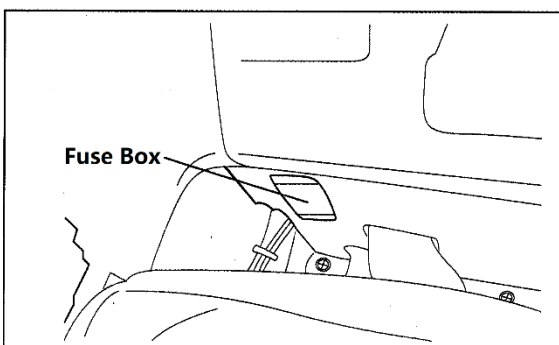

- (A) If electrical equipment does not work, check the fuse firstly. Fuse box in the lower part of the seat. Fuse location, specification sheets attached to the fuse box cover.
- (B) Open the fuse box cover. Spare fuses are located under the hood side.



Install a fuse with the correct amperage guard against damage due to overload electrical system.

Each fuse amperage and function Fig in fuse box:

Nineteen road insurance signs schematic

Start	10A	Cabin light	20A
Preheat	10A	Radio	10A
Solenoid switch	10A	Air conditioner	20A
Generator excitation	10A	flashlight	30A
Meter	10A	Hore	30A
Parking	10A	Spare	10A
Safety valve	10A	Spare	10A
wiper	20A	Spare	20A
Pump(Yanmar)	30A	Spare	30A
Flameout solenoid valve	30A		

5-6. Replacement of bucket

5-6-1. Change bucket

⚠ CAUTION

When knocking the pin, metal particles may fly and cause serious injury. When carrying out this operation, always wear safety goggles or safety glasses and utensils for the job.



(A) Park the machine on level ground; the bucket lowered to the ground, and it is positioned on the ground plane. Make sure the bucket does not scroll after removing the pin.

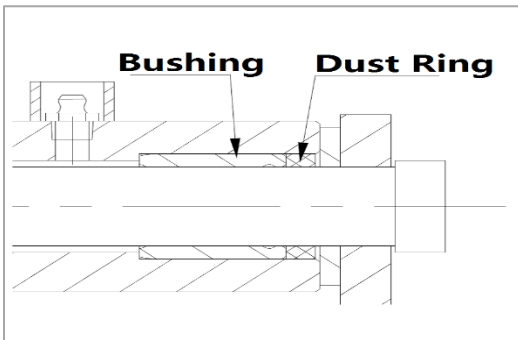

(B) Remove the pin of A and B, separate the arm and bucket. Clean up the pin, Pin holes and dust ring. Smear enough lubricating oil on the pin and pin hole.

(C) Adjust the arm and new bucket, Make sure the bucket does not scroll.

(D) Install pin A and pin B.

(E) Install locking pin and retaining ring on the Pin A and pin B

(F) Adjust the connecting gap of pin A.

(G) Add grease to the pin A and pin B.

(H) Start the engine and operate with low speed.

Manipulate the bucket operation, slowly rotate the bucket to two directions, to check if there is any interference when the bucket move on. Do not use any machine with interference. If interference, deal with it in time.

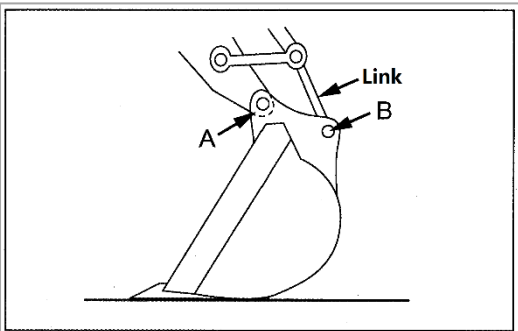

5-6-2. Change bucket and connect to bucket

⚠ CAUTION

- When knocking the pin, metal particles may fly and cause serious injury. When carrying out this operation, always wear safety goggles or safety glasses and utensils for the job.
- The bucket is rotated 180 degrees to provide adequate space, before starting to change jobs, get around people away from the machine, if you use the signalman, before starting to coordinate hand signals.

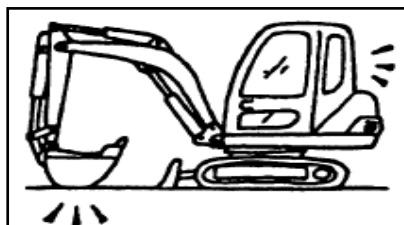

(A) Park the machine on level ground; the bucket lowered to the ground, and it is positioned on

Maintenance-Replacement of Bucket

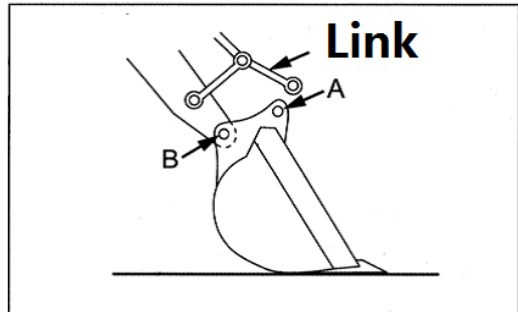
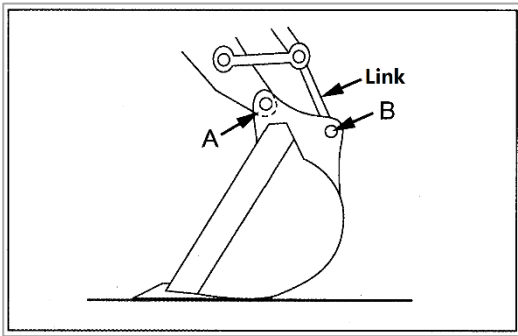
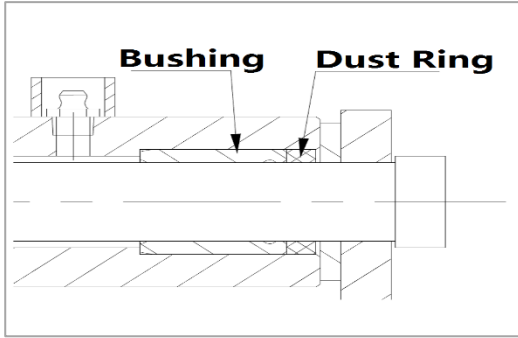
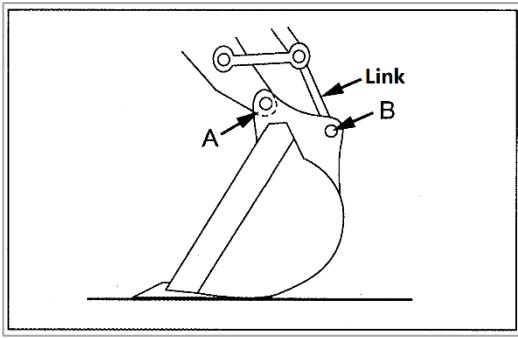

the ground plane. Make sure the bucket does not scroll after removing the pin.

- (B) Remove pin A and pin B, separate arm and bucket. Clean up the pin, Pin holes and dust ring. Smear enough lubricating oil on the pin and pin hole

- (C) Rotary the bucket 180 degrees. Make sure the bucket does not scroll

- (D) Adjust the arm and bucket, install pin A and pin B, and then install locking pin to the pin A and pin B.

- (E) Add lubrication oil to pin A and pin B.

- (F) Start the engine and operate with low speed. Manipulate the bucket operation, slowly rotate the bucket to two directions, to check if there is any interference when the bucket move on. Do not use any machine with interference. If interference, deal with it in time.

5-6-3. Adjust bucket connection

There is a bucket adjustment system to eliminate the connecting gap. When the connecting gap is too big, use the method removed or installed shims.



- (A) Parking the machine on the level ground. Make the flat side downward, Put the bucket lowered to the ground to avoid rolling.

- (B) Start the engine with low speed. Fixed bucket on the ground, Slowly and gradually counterclockwise rotate platform until the the left inside of bucket close contact with the arm end surface.

Maintenance-Replacement of Bucket

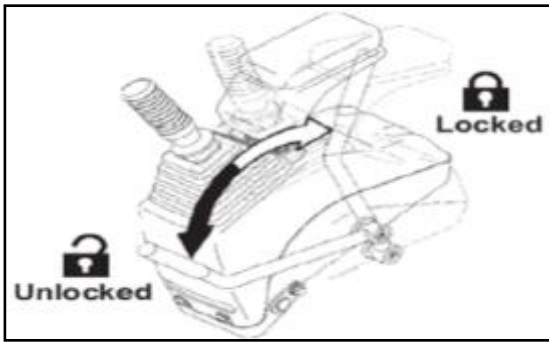

(C) Stop the engine, pull the pilot control knob to the locked position.

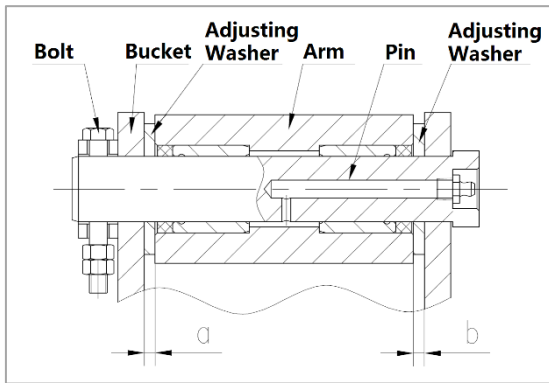

(D) Loose the bolt(M8) with 13mm wrench. Take out the pin, fill in the appropriate thickness washer in the adjustment washer, try to ensure that the consistent size between a, b.

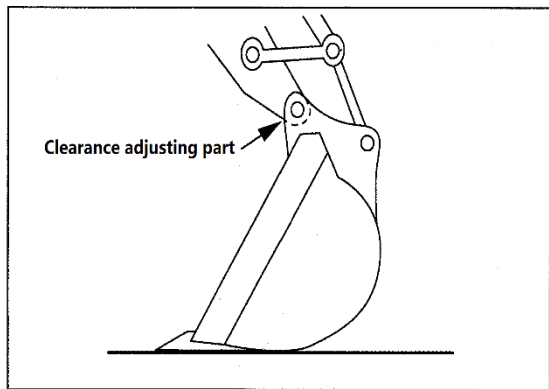

(E) Align the mounting holes, install the pin, when assembly, as far as possible to ensure consistent between the bolts assembly bolt and bucket assembly bolt, tighten the nut.

(F) Fill in butter after assembly.

CAUTION

Take out pin, observe the wearing of pin and bushing, if badly worn, replace in time.

5-7. Track Check

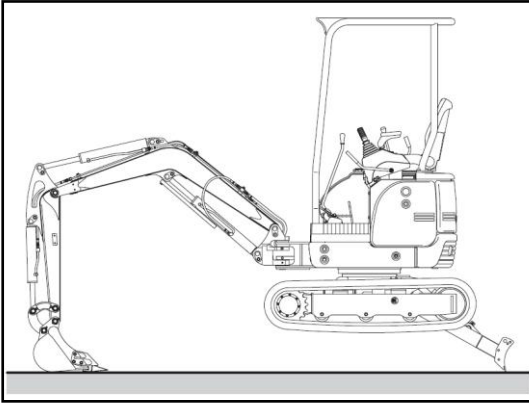

- (A) Push down the dozer propped to the limit position.
- (B) Put the bucket in appropriate position, propped up boom, keep the angle between boom and arm within the scope of 90 degrees to 100 degrees, and place the bucket arcuate portion on the ground.
- (C) Rotating tracks back two complete turns, then rotating tracks forward two complete revolutions.
- (D) The closed distance between supporting wheels and tracks outer is the amount of sag.
- (E) Tracks sag amount prescribed value: 20mm~40mm

5-7-1. Adjust Track droop

Notes of adjust the track Sag amount:

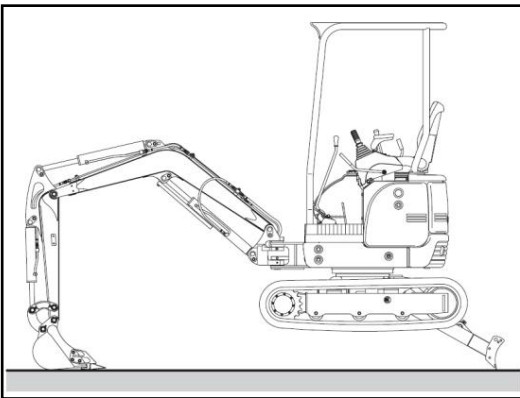

- (A) If the track sag amount is not within the prescribed value, loose or tighten tracks according to the following steps:
- (B) When adjust the tracks sag amount, propped up excavator.
- (C) After adjust the sag amount of both side tracks, Moved the machine back and forth several times.
- (D) Check the sag amount again, if still can not up to the standard, continue to adjust, until to obtain the exact sag amount.

5-7-2. Loose track

CAUTION

- Do not loosen or excessive valve ① quickly, otherwise the lubrication oil in the the track tensioning will be ejected. Care should be taken to put the valve ① release, does not transform the body and face against the valve ①.
- Absolutely not allowed to loosen grease nipple ②.
- If there is dirt or gravel sandwiched between the sprocket and rail links, yremove them before loosen the track.

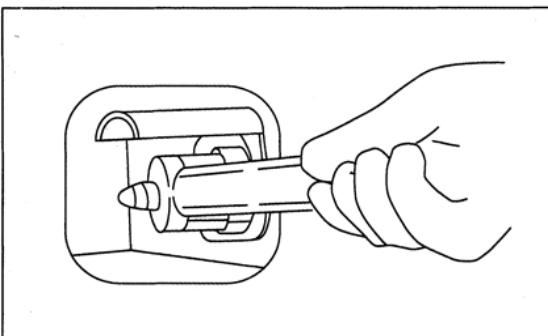

- (A) When loosen the tracks, slowly counterclockwise rotate the valve ① with with 24 long socket wrench. Grease from the grease outlet
- (B) It is enough to loose tracks when turn the valve ① 1 ~ 1.5 laps.

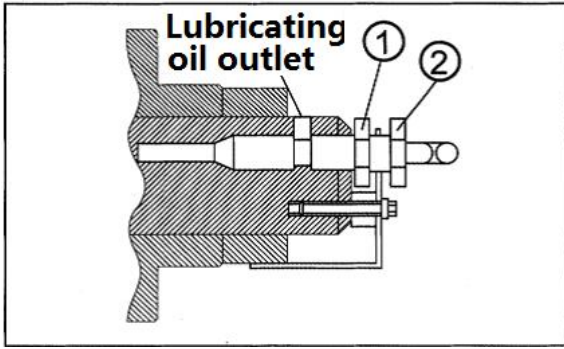

- (C) The grease can not drain smoothly, lifted the tracks off ground, and rotate tracks slowly.
- (D) After obtaining the proper track sag amount, clockwise to tighten the valve ① to 147N·m (15kgf·m) .

5-8. Bolt and Nut Check

IMPORTANT

- Use a torque wrench to check and fasten the bolts and nuts torque specifications.
- Before installing, ensure the threaded bolt and nut is clean.
- Coat lubricant to the bolt and nut (such as lubricating oil dissolved in white zinc b), in order to stabilize their coefficient of friction.
- If the counterweight mounting bolts are loose, tighten timely; contact with Carter engineers and distributors.

(A) tightening torque specifications

Metric nuts and bolts			
Thread Size	Standard tightening torque (N · m)	Thread Size	Standard tightening torque (N · m)
M6	9-12	M14	124-165
M8	22-30	M16	193-257
M10	45-59	M20	376-502
M12	78-104		

(B) Bolt tightening torque value on major part (N·m) :

Thread Size	Standard tightening torque
M14 Travel motor mounting bolts	180-210
M14 Driving wheel mounting bolts	180-210
M16 Supporting slewing mounting bolts	280-330
M16 Swing construction mounting bolts	280-330
M12 Sprocket wheel mounting bolts	110-130
M20 counterweight mounting bolts	540-650

CAUTION

tightening torque: kgf·m

For example, 1m wrench when tightening bolts or nuts, rotate the end with 12kgf power, it will result in the following torque:

$$1\text{m} \times 12\text{kgf} = 12\text{kgf} \cdot \text{m}$$

If you want to produce the same torque with 0.25 wrench: $0.25\text{m} \times y = 12\text{kgf} \cdot \text{m}$

$$\text{Force needed: } y = 12\text{kgf} \cdot \text{m} \div 0.25 = 48\text{kgf}$$

5-9. Maintenance in Special Situation

Operating Conditions	Maintenance Precautions
Peatlands, wet weather or snow	<p>Before the operation: Check the bolts and make sure all emissions bolts are tightened.</p> <p>After the operation: check all nuts and bolts, if there is broken,damaged,loose or missing.</p> <p>Lubricating all parts which must be lubricated in time.</p>
Seaside	<p>Before the operation: Check the bolts and make sure all emissions bolts are tightened.</p> <p>After the operation: clean up machine with water,to wash sway the salt. Regular maintenancethe electrical equipment, in order to avoid corrosion.</p>
Dusty environment	<p>Air filter: periodically on their short maintenance intervals sweep filter</p> <p>Radiator: cleaning oil cooler grille to prevent clogging of the radiator core.</p> <p>Fuel system: periodically on their short maintenance intervals sweep filter.</p> <p>Electrical Equipment: regular cleaning, especially alternators and starter rectifier surface.</p>
Stony ground	<p>Tracks:Careful operation.check all nuts and bolts, if there is broken,damaged,loose or missing.Make the tracks slightly more relaxed than usual.</p> <p>Working device: Dig the stony ground, standard parts may be damaged.Strengthen the bucket or use the heavy duty bucket.</p>
Freezing weather	<p>Fuel: use the high quality fuel suitable for low temperature.</p> <p>Lubricants: use high quality hydraulic oil and engine oil with low viscosity.</p> <p>The engine coolant: be sure to use antifreeze.</p> <p>Battery: the short maintenance interval regularly enough battery power, if not enough electricity, electrolyte may freeze.</p> <p>Tracks:keep tracks clean.Parked machine on solid ground, lest the crawler frozen on the ground.</p>
Rockfall	<p>Cabin: Install cabin protection device to protect the machine from damage by falling rocks.</p>

5-10. Machine Storage

- (A) Check the machines, repair worn or damaged parts.If necessary,put on the new parts.
- (B) Clean up the pre-air filter.
- (C) If possible,retract all the hydraulic cylinders.If impossible,coat grease to the showing hydraulic cylinder piston rod.
- (D) Lubricate all lubricating points
- (E) Placed tracks on the block with enough length and stable.
- (F) Clean up the machine. Especially in winter,clean up every parts especially tracks.
- (G) After the battery full charge, remove the battery and put it in a dry and safety place.If not remove,separated from (-) terminals on the battery negative cable connection.
- (H) Fill in corrosion inhibitor in cooling water. When the temperature is lower than -35°C ,drain the cooing water in the machine. If pull up cooling system,be sure to put on "the radiator without water" sign.
- (I) Relax alternator belt and the cooling fan.
- (J) Painting where necessary to avoid rust.
- (K) Parked machine in a dry and safe place.If put outdoor, should be on the waterproof cover.
- (L) If storage machine for a long period of time, operation machine at least once a month.

5-11. Remove machine in storage

WARNING

- Start the engine in ventilated place.
 - If the machine is not used for a long time, sliding on the surface of a thin oil layer may be damaged. It is necessary to walk cycle, the revolving mining hydraulic function of 2 to 3 times, with lubrication sliding surface.
- (A) If the hydraulic cylinder piston rod is coated with grease, must be removed.
- (B) Adjust the alternator and fan belt tension.
- (C) Fill full fuel tank. For fuel exhaust system. Check all the liquid level.
- (D) Start the engine. Before the full load operation, operating engine with a low speed for a few minutes.
- (E) Cycle all hydraulic functions for several times.
- (F) Before to full load operation, carefully check all the system.

CAUTION

When the machine stored for a long time, still must ensure that implement the following steps:

- 1) check all the hose and the connection status.
- 2) Preheating engine.
- 3) Turn off the engine.
- 4) Fitted with a new fuel filter. Replace the engine oil filter and injection engine.

Chapter 6. Troubleshooting

6-1. Not failure's situation

Notice, the following situation is not failure:

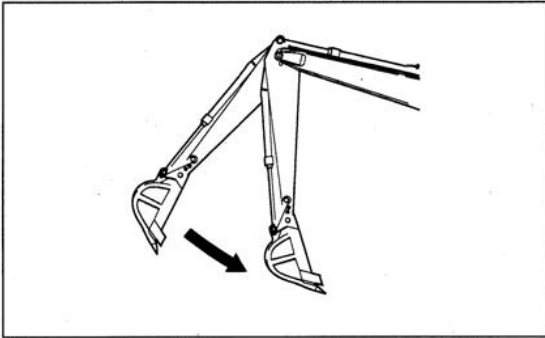

1. When placing arm operating lever on digging position, working device drops down from high position in noload, when arm exceeds or less than vertical position, arm speed will drop instant.

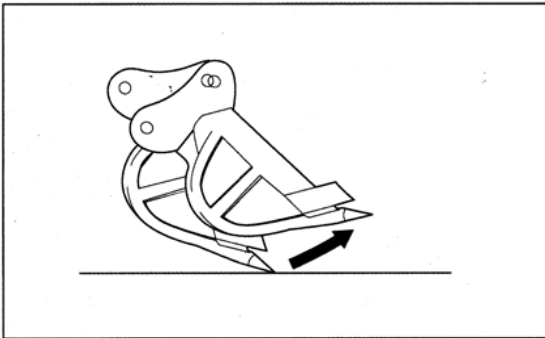

2. when placing bucket operating lever on digging position, working device drop down from high position in noload, when bucket teeth exceeds or less than level position, bucket speed will drop instant.

3. When digging in heavy load, bucket or arm shakes.
4. When start or stop swing, the brake valve noise.
5. when driving down a steep slope at a low speed, the motor noise.

6-2. Start engine with auxiliary cable

When using auxiliary cable to start engine, please do according to the following steps:

6-2-1. Connection and disconnection auxiliary cable

- (A) This machine's starting system uses 12V voltage. For normal machine, also uses 12V battery.
- (B) Auxiliary cable and cable clamp's specification should be suitable for battery.
- (C) The battery capacity of the normal machine must be the same as the battery capacity of the engine to be started.
- (D) Check whether the cable and wire clips are damaged or corroded.
- (E) Make sure that the cable is securely attached to the wire clip.
- (F) Check the machine safety lock lever is in the locked position.
- (G) Check whether the joystick is in the median position.

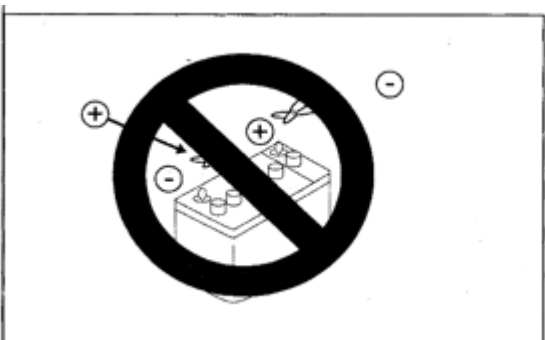

6-2-2. Connection of auxiliary cable

The starting switch of the normal machine and the faulty machine is placed in the OFF position.

Connect the auxiliary cable according to number order which is indicated in the diagram and the following steps.

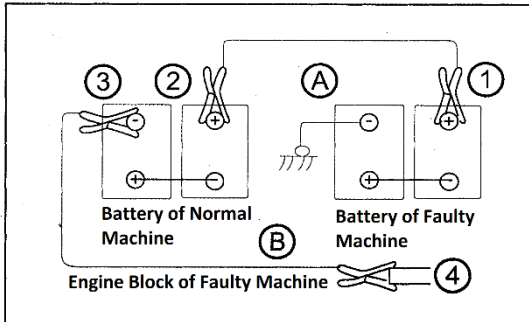

- (A) Make sure the starting switch of the normal machine and the faulty machine is placed in the OFF position.
- (B) Connect the auxiliary cable (A) to the positive (+) terminal of the faulty machine.
- (C) Connect the auxiliary cable (A) to the positive (+) terminal of the normal machine.
- (D) The auxiliary cable (B) is connected to the normal machine's negative pole (-) terminal.
- (E) Connect the auxiliary cable (B) to the engine block of a faulty machine.

6-2-3. Start Engine

Ensure the safety of both normal machine, or a defective machine, Machine safety lock lever should be in lock position. Also check all lever should be in the position of maintain or median.

- (A) Ensure that the wire clip tightly connected to the battery terminals.
- (B) starting normal engine and keep high speed.
- (C) For the defective machine, starting switch turn to START position and START the engine. If the engine not starting for the first time, starting again in 3 minutes.

6-2-4. Disconnection of auxiliary cable

Start the transmitter, disconnect auxiliary cable according to the In contrast to the connection of the order.

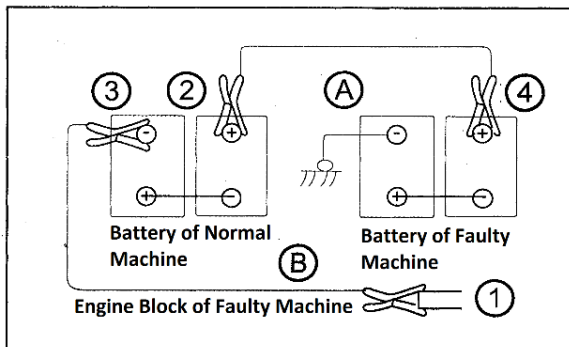

- (A) Remove the auxiliary cable (B) clamp from a defective machine of engine cylinder body.
- (B) Remove the auxiliary cable (B) clamp from a normal machine of engine cylinder body
- (C) Remove the auxiliary cable (A) clamp, from the positive (+) terminal of the normal machine.
- (D) Remove the auxiliary cable (A) clamp, from the positive (+) terminal of the defective machine.

6-3. Troubleshooting

6-3-1. Engine

Fault phenomenon	Cause analysis	Elimination method
The engine could rotate but can not starting or difficult starting	No fuel Incorrect fuel Dirty fuel Low battery power Jet pump working poor Pre hotline or glow plug is incorrect Bad wire connection Starter motor failure Engine oil error Air filter clogged Fuel filter clogged Engine low compression Poor injection nozzle dirty work Fuel cut linkage Fuel system leaks Air in the fuel system Fuel pump plunger bounce Pump filter dirty	Added fuel, Exhaust air Discharge tank. Use the correct fuel Discharge tank. Use clean fuel Charge or install new batteries Contact with Carter Service Engineer Contact with Carter Service Engineer Clean and tighten the connection between battery and the starter motor Replace starter Discharge oil. Use the correct oil Replace filter Discharge air from fuel system. Clean up fuel tank filter Contact with Carter Service Engineer Contact with Carter Service Engineer Adjust or repair linkage Check the connection of fuel system Exhaust air Push down and tighten the handwheel Clean or replace
Engine is pop. Abnormal operation or stop	Engine oil level is low Air intake system clogged Pump filter is dirty The spray pump is not in time Filter oil filter clogged Low cooling water temperature Water, or air in the fuel system Dirty or faulty in injection nozzle Fuel cut linkage	Fill in oil Clean up filter and system Clean or replace Contact with Carter Service Engineer Install new filter The thermostat is not working properly or too cold Exhaust air from the fuel system, clean up the fuel tank outlet strainer Contact with Carter Service Engineer Adjust or fix linkage device
Engine power can not be fully use	Air filter clogged Fuel line blocked Contaminated Fuel Fuel filter clogged Fuel tank cap vent hole clogged Dirty or faulty injection nozzle Adjusting the injection pump linkage Incorrect fuel Wrong oil Pump spray is not in time	Replace filter Fix or replace fuel line Discharge fuel tank, clean up filter and fill in oil Replace filter Clean or install new cover Contact with Carter Service Engineer Contact with Carter Service Engineer Use correct fuel oil Use correct oil Contact with Carter Service Engineer

Troubleshooting

	Exhaust blocked Engine is too hot or too cold Engine Trouble Intake or exhaust system leak	Remove the muffler and start the engine As followed problems Contact with Carter Service Engineer Contact with Carter Service Engineer
Fault phenomenon	Cause analysis	Elimination method
Engine is too hot	Coolant level is too low Thermostat failure Engine overload Bad radiator cap Radiator core and oil cooler core plugged Radiator grille clogged The pump spray is not in time The fan is broken Air filter clogged Alternator and fan belt slack Pulley wear grass Dirty cooling system channel Thermometer or transport unit failure	Fill in coolant Contact with Carter Service Engineer Check hydraulic safety valve Install new cover Clean up radiator and oil cooler Clean up nets Contact with Carter Service Engineer Replace fan Clean up air filter Tighten or install new belt replace belt wheel Wash cooling system Contact with Carter Service Engineer
Cooling water temperature is too low	Thermostat failure Thermometer or transport unit failure	Contact with Carter Service Engineer Contact with Carter Service Engineer
Low engine oil pressure	Engine oil pump or pump drive device Low oil level Engine oil pressure regulating valve Pump suction hood network clogged Oil filter clogged Oil Leak The oil is diluted by fuel or cooling water Engine temperature is too high Incorrect oil	Contact with Carter Service Engineer Fill in oil Contact with Carter Service Engineer Contact with Carter Service Engineer Install a new oil filter Check leakage Contact with Carter Service Engineer Cheak cooling system Discharge oil, usd the correct oil
More engine oil consumption	Incorrect oil Oil Leak Engine temperature is too high Air filter clogged Internal engine component wear	Discharge oil, use the correct oil Check the engine oil drain plug Check cooling system Clean or install new filter Contact with Carter Service Engineer
More engine fuel consumption	Air intake system clogged or dirty Incorrect fuel Fuel injection nozzle Pump spray is not in time	Clean up air intake system Use the correct fuel Contact with Carter Service Engineer Contact with Carter Service Engineer
Too black or gray smoke	Air intake system clogged or dirty Incorrect fuel Fuel injection nozzle is dirty or failure Pump spray is not in time Engine body failure	Discharge fule tank, use the correct fuel Clean up air intake system and discharge system Contact with Carter Service Engineer Contact with Carter Service Engineer Contact with Carter Service Engineer

Troubleshooting

No working	Battery	Charge or replace
No working(except clock)	Battery Relay	Replace relay
Lack of battery power	Loose or corroded connections Alternator belt slack The engine is not charging fuse Key switch failure	Clean,tighten or replace battery Tighten or install new belt Contact with Carter Service Engineer Replace fuse Replace key switch
Fault phenomenon	Cause analysis	Elimination method
Start moto is no working	The battery charge is low or damaged Poor battery cable connections Blown fuse Key switch Starting relay Starter solenoid Starter Starter pinion gear is stuck in the flywheel Main engine failure	Charge or replace battery Clean up connection part Repalce fuse Contact with Carter Service Engineer Contact with Carter Service Engineer Contact with Carter Service Engineer Fix or replace starter motor Fix or replace starter Contact with Carter Service Enginee
Starters electromagneti c vibration	Poor connection to the battery or starter Lack of battery power Starter solenoid "hold" coil opened	Clean up connection part Charge or replace battery Contact with Carter Service Engineer
Starter motor rotates but does not start the engine	Starter pinion not engages on the flywheel ring gear Pinion mechanism becomes stuck or fault Pinion tooth fracture Flywheel gear tooth fracture	Contact with Carter Service Engineer Contact with Carter Service Engineer Contact with Carter Service Engineer Contact with Carter Service Engineer
Engine start slow	Battery wire internal breakage or damage Battery or starter wire connections is loose or corroded	Check and replace the wire Cleaning and fastening
White exhaust	Wrong fuel Engine too cold Thermostat failure or too "cold" The pump spray is not in time Cooling water leaked into the engine cylinder	Discharge oil tank, usd the correct fuel Start engine until it is hot Contact with Carter Service Engineer Contact with Carter Service Engineer Contact with Carter Service Engineer
Turbocharger noise or vibrations	Bearing no lubrication Worn bearing Air leakage in engine, intake or exhaust duct Undue gap between the turbine and the turbine housing Crushing blade of the turbine	Insufficient oil pressure Check the blocked turbocharger oil pipeline Contact with dealer or Carter Service Engineer Check, fix Contact with dealer or Carter Service Engineer Check exhaust elbow hose and and air intake hose

Troubleshooting

<p>Turbocharger joint leakage</p>	<p>Bad or worn bearings and (or) worn seals</p> <p>Crankcase pressure is too high</p> <p>Turbocharger oil return pipe is occurs carbon blockage through the exhaust duct.</p>	<p>Contact with dealer or Carter Service Engineer</p> <p>Check, clean up air filter</p> <p>Check the engine maintenance interval is appropriate or whether there is dirt enter the engine.</p> <p>Contact with dealer or Carter Service Engineer</p> <p>Check, clean up</p> <p>Remove the pipe</p> <p>Check, clean up</p>
<p>Turbocharger rotating member resistance is too large</p>	<p>As burning sediments to make clogging of turbine rear</p> <p>Compressor rear wheel clogged due to the air intaked into pipline and leakage</p> <p>Bearing stuck,dirty or worn because of high stability, unbalanced impeller, dirty oil, lack of oil or inadequate lubrication</p>	<p>Check, clean up</p> <p>Check, clean up</p> <p>Contact with dealer or Carter Service Engineer</p>

6-3-2. Electrical System

Problem	Cause	Treatment
Engine starts too slowly	Battery leakage or it can not hold save power. Starter "the drag" Low battery voltage	Replace battery Contact appointed dealer or service engineer from Carter Charge or replace battery
Starter motor still runs after engine works	Starter relay suck Starter solenoid suck Starter constantly open Key switch	Contact appointed dealer or service engineer from Carter
Charging pilot lamp still lights when engine is running	AC generator belt loose or slipping Low engine speed Excessive electrical overload caused by the additional accessories Batteries, grounding strip, starter or AC Loose or corroded electrical generators connected to the battery voltage is low Alternator or regulator malfunction LED circuit failure	Check belt If slipping replace it; if relaxation, tense it. Adjust the speed to a predetermined value Remove additional accessories or install higher output alternator Check, clean or tighten electrical connections Recharge or replace the battery Contact appointed dealer or service engineer from Carter Contact appointed dealer or service engineer from Carter
Alternator is nosiy	Worn drive belt Worn pulley Improper pulley adjustment Alternator Bearing Alternator	Replace the belt Replacing the pulley and belt Adjustable mounting alternator Loosen the alternator belt Pulley turned by hand (If you feel any rough, repair the alternator)
All pilot lamps in monitor don't work.	Fuse Electrical wiring and Pilot lamp	Replace fuse Contact appointed dealer or service engineer from Carter
Certain pilot lamp in monitor does not work.	Pilot lamp Fuse Electrical wiring	Replace light lamp Replace fuse Contact appointed dealer or service engineer from Carter
Certain pilot lamp does not work on the dial	Circuit board Electrical wiring Fuse Screen	Contact appointed dealer or service engineer from Carter Contact appointed dealer or service engineer from Carter Replace fuse F10 Contact appointed dealer or service engineer from Carter
Certain pilot lamp does not work on the dial	Pilot lamp Fuse Sensor Electrical wiring	Replace light lamp Replace fuse Replace indicator Contact appointed dealer or service engineer from Carter
Temperature sensor don't work.	Fuse Screen Temperature sensor Electrical wiring	Replace fuse Replace screen Contact appointed dealer or service engineer from Carter Contact appointed dealer or service engineer from

Troubleshooting

		Carter
Pilot lamps don't work	Fuse Electrical wiring	Replace fuse Contact appointed dealer or service engineer from Carter
Fuel meter does not work.	Fuse Fuel sensor Electrical wiring Screen	Replace fuse Contact appointed dealer or service engineer from Carter Contact appointed dealer or service engineer from Carter Contact appointed dealer or service engineer from Carter

6-3-3. Hydraulic System

Problem	Cause	Treatment
Hydraulic functions is too slow	<p>Low oil level Oil is too cool Wrong oil Generator speed is too low</p> <p>Pilot circuit pressure is too low</p> <p>Worn pump</p> <p>Pump suction pipe line blocked</p>	<p>To reserve fuel tank to full scale Press the hydraulic oil warm-up switch Discharge of oil, fuel the correct oil Speed up or Contact appointed dealer or service engineer from Carter</p> <p>Contact appointed dealer or service engineer from Carter</p> <p>Contact appointed dealer or service engineer from Carter</p> <p>Contact appointed dealer or service engineer from Carter</p>
Hydraulic oil overheating	<p>Wrong oil The pump suction pipe line inner leakage Blocked oil pipeline</p> <p>Low oil level Filter clogging Worn pump</p> <p>Clogged radiator or oil cooler Oil cooler bypass</p> <p>Safety valve</p> <p>Contaminated oil Travel motor</p> <p>Hydraulic components are improperly adjusted</p>	<p>Fill the correct hydraulic oil Contact appointed dealer or service engineer from Carter</p> <p>Contact appointed dealer or service engineer from Carter</p> <p>To reserve fuel tank to full scale Install the new filter Contact appointed dealer or service engineer from Carter</p> <p>Cleaning and straightening vanes Contact appointed dealer or service engineer from Carter</p> <p>Contact appointed dealer or service engineer from Carter</p> <p>Contact appointed dealer or service engineer from Carter</p> <p>Drain and fill the clean oil Contact appointed dealer or service engineer from Carter</p> <p>Contact appointed dealer or service engineer from Carter</p>
Oil foam	<p>From the storage tank to the pump tubing leak Oil pipeline twist or sag Wrong oil Water in oil High or low oil level</p>	<p>Repair leakage or Contact appointed dealer or service engineer from Carter</p> <p>Check pipelines</p> <p>Fill the correct hydraulic oil</p> <p>Replace oil</p> <p>Check oil lever</p>
Low or no oil pressure	<p>Wrong oil Hydraulic components are improperly adjusted No oil in the system Worn hydraulic cylinder parts</p> <p>Safety valve</p>	<p>Use right hydraulic oil Contact appointed dealer or service engineer from Carter</p> <p>Fill the correct hydraulic oil Contact appointed dealer or service engineer from Carter</p> <p>Contact appointed dealer or service engineer from Carter</p>
No hydraulic functions (pump abnormal sound)	<p>Hydraulic pump</p> <p>Lack of hydraulic oil Suction line or hose is worn</p>	<p>Contact appointed dealer or service engineer from Carter</p> <p>Refuel</p> <p>Contact appointed dealer or service engineer from Carter</p>

Troubleshooting

	The suction filter clogging	Clean
Hydraulic cylinders work but can not lift load	Cylinder wears Main pressure relief valve Hydraulic oil level is low Suction filter clogged Pump suction line leak	Contact appointed dealer or service engineer from Carter Contact appointed dealer or service engineer from Carter Refuel Contact appointed dealer or service engineer from Carter Check pipes
Certain control lever does not work	Low pressure relief valve Tube or hose damage Hydraulic fittings loose O-ring in the joint damage Hydraulic pump Pilot valve Pilot lines	Contact appointed dealer or service engineer from Carter Repair or replace Tighten Replace new O ring Contact appointed dealer or service engineer from Carter Contact appointed dealer or service engineer from Carter Repair or replace
Certain hydraulic cylinder does not work	The control spool damaged or dirt contamination Damaged hydraulic lines Joint laxity O-ring in the joint damage Pilot valve Pilot line	Contact appointed dealer or service engineer from Carter Repair or replace Tighten Replace new O ring Contact appointed dealer or service engineer from Carter Repair or replace
Certain hydraulic cylinder does not work or is without power	Hydraulic cylinder piston seal leakage Hydraulic cylinder rod damage Pilot line Pilot valve Bad electrical wiring	Contact appointed dealer or service engineer from Carter Contact appointed dealer or service engineer from Carter Repair or replace Contact appointed dealer or service engineer from Carter Contact appointed dealer or service engineer from Carter
Two travel motors do not work	Central swivel joint failure	Contact appointed dealer or service engineer from Carter
A traveling motor does not work	Travel motor Brake does not release Pilot valve Pilot line	Contact appointed dealer or service engineer from Carter Contact appointed dealer or service engineer from Carter Contact appointed dealer or service engineer from Carter Repair or replace
Walking is not smooth	Track tensioning mechanism Track tensioning wheel, sprocket wheel or rollers Curved track frame There is a stone or mud in the track	Adjust tension Contact appointed dealer or service engineer from Carter Contact appointed dealer or service engineer from Carter Remove it and repair

Troubleshooting

	frame. Walking Brake does not release	Contact appointed dealer or service engineer from Carter
Swing does not work	Rotating brake release valve Swing motor Pilot valve	Contact appointed dealer or service engineer from Carter
Swing is not smooth	Swing bearing gear Swing bearing Lack of grease	Contact appointed dealer or service engineer from Carter Contact appointed dealer or service engineer from Carter Grease more
When move walking or moving control lever, engine stop.	Poor contact Bad electrical wiring The main controller damage	Repair or replace Contact appointed dealer or service engineer from Carter Contact appointed dealer or service engineer from Carter

6-3-4. Control Lever

Problem	Cause	Treatment
Difficult to move	Corrosion joint body Worn pusher	Contact appointed dealer or service engineer from Carter
Do not do movement	Worn pusher Pilot valve	Contact appointed dealer or service engineer from Carter
Does not return to neutral; Too loose; The operating lever is not at neutral vertical	Pilot valve Worn transmission joint body Pilot valve	Contact appointed dealer or service engineer from Carter

6-3-5. Mode selection

Problem	Cause	Treatment
Working mode selection switch does not work	Mode switch Electronic connectors Pilot pressure switch bad wiring main controller Solenoid valve unit	Contact appointed dealer or service engineer from Carter
High / low travel speed does not work	Walking mode switch Pilot pressure switch (walking) Pump delivery pressure sensor wiring main controller Solenoid valve unit Damaged motor running	Contact appointed dealer or service engineer from Carter
Automatic idle does not work	fuse Switchboard Electrical fittings Electrical wiring EC motor Pressure switch (walking, working device) main controller	Replace fuse Contact appointed dealer or service engineer from Carter

Chapter 7. Technical Parameters

7-1. Performance parameters

Model		CT16-9B Series	
Bucket Capacity (m ³)		0.04	
Operating Weight (t)		1.7	
Engine	Model	Yanmar 3TNV70	Yanmar 3TNV76
	Specification (kW/rpm)	10/2200	14.1/2400
A: Total Length(mm)		3707	3707
B: Track Length(mm)		1588	1588
C: Track Width min/max(mm)		990/1320	990/1320
D: Overall Width (mm)		1000	1000
E: Overall Height (top of Cabin/canopy)(mm)		2424	2424
F: Counterweight Ground Clearance(mm)		484	484
G: Min Ground Clearance (mm)		175	175
H: Rail Swing Radius (mm)		665	665
I: Track Ground Length (mm)		1210	1210
K: Track Shoe Width (mm)		230	230
Ground Pressure (kPa)		28	28
Swing Speed (rpm)		8.5	8.8
Travel Speed (km/h)		2.1/4.2	2.2/4.2
Gradeability		58%	58%

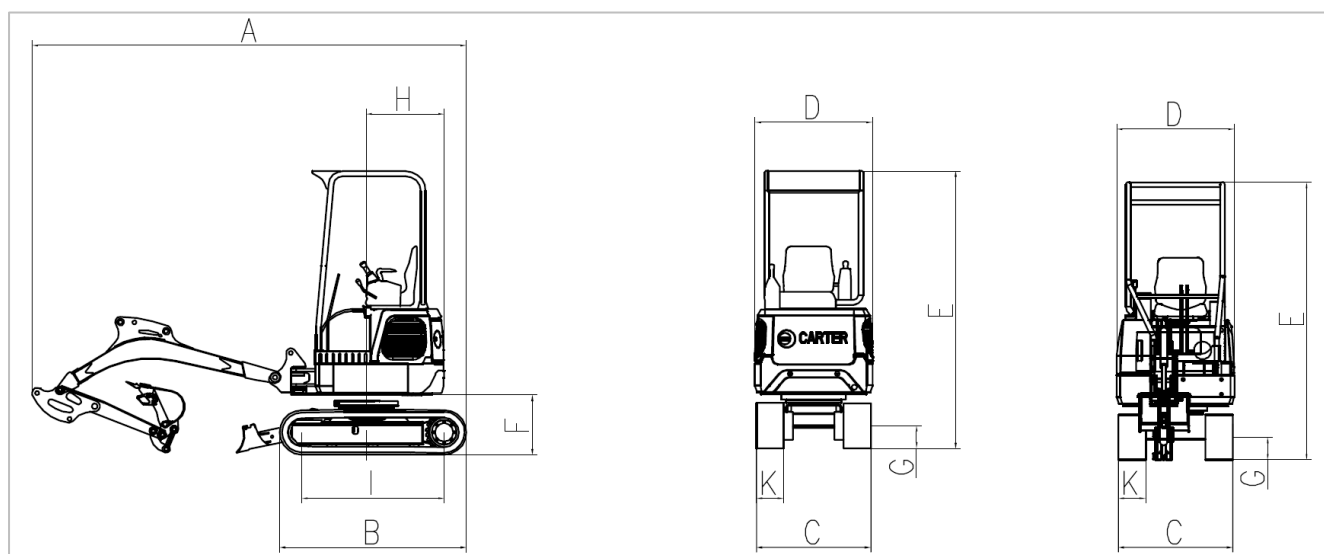

Technical Parameters

Model		CT18-9B	CT18-6L
Bucket Capacity (m ³)		0.04	0.04
Operating Weight (t)		1.8 (canopy) / 1.9 (cabin)	1.8
Engine	Model	Yanmar 3TNV76	LD385D
	Specification (kW/rpm)	14.1/2400	18.4/2350
A: Overall Length (mm)		3867	3867
B: Track Length (mm)		1588	1588
C: Track Width min/max(mm)		990/1320	1080
D: Overall Width (mm)		1000	1000
E: Overall Height (top of canopy)(mm)		2313	2261
F: Counterweight Ground Clearance (mm)		484	454
G: Min Ground Clearance(mm)		175	175
H: Rail Swing Radius (mm)		1072	1072
I: Track Ground Length (mm)		1210	1210
K: Track Shoe Width (mm)		230	230
Ground Pressure (kPa)		28	28
Swing Speed (rpm)		8.8	10.8
Travel Speed (km/h)		2.2/4.2	2.4
Gradeability		58%	58%

7-2. Digging Swing Range

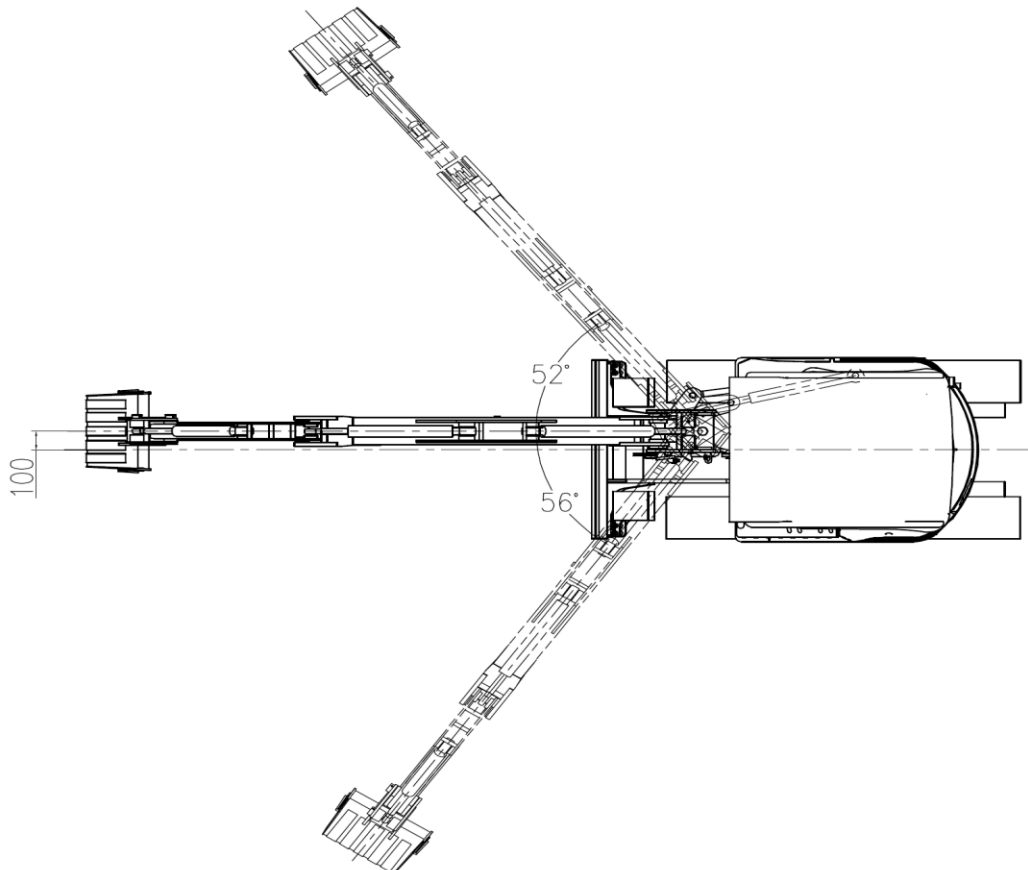

7-3. Working range

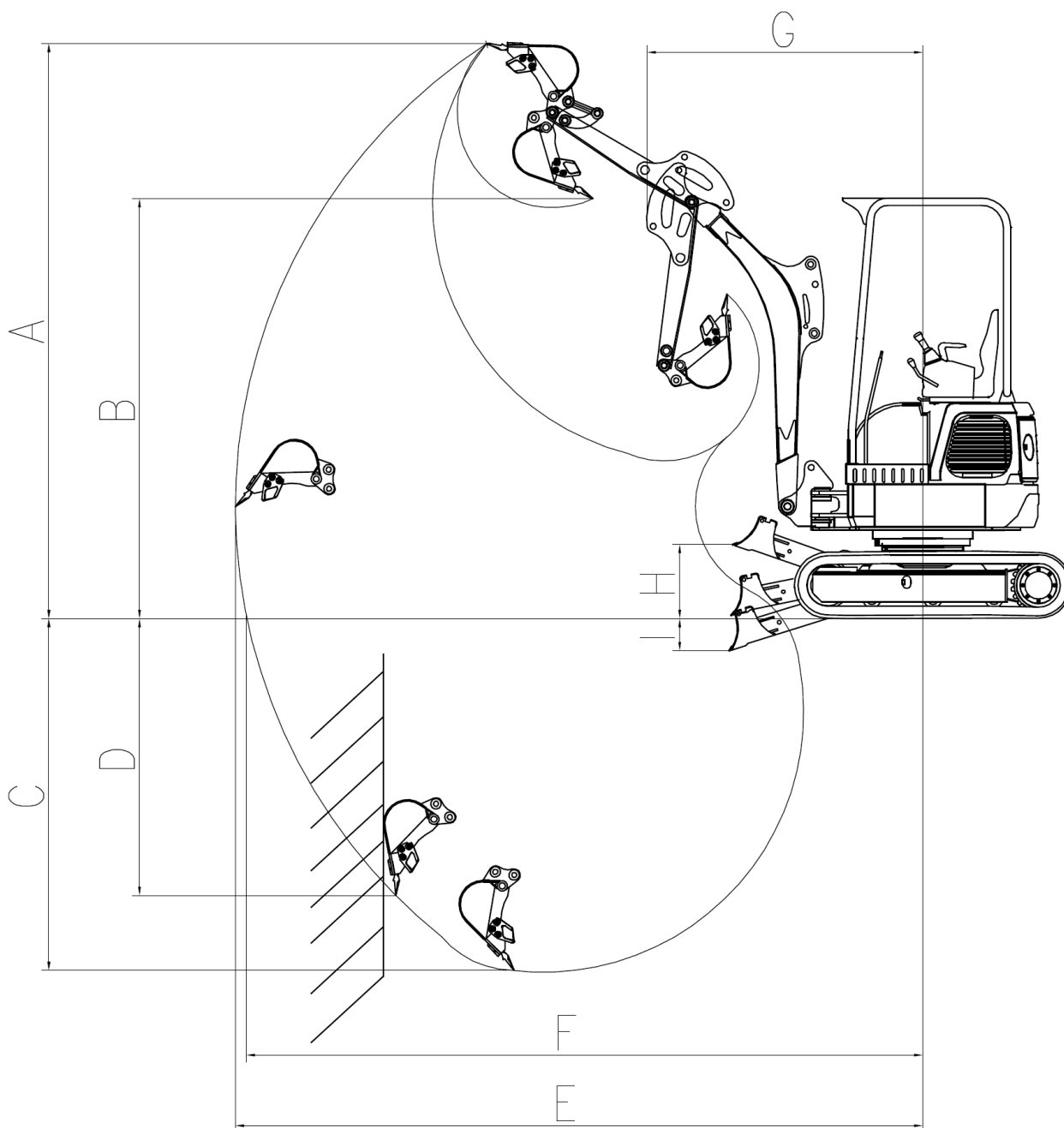

Model	CT16-9B	CT18-9B	CT18-6L
A: Max Digging Height(mm)	3296	3327	3243
B: Max Dumping Height(mm)	2408	2361	2355
C: Max Digging Depth(mm)	2033	2110	2071
D: Max Vrtical Digging Depth(mm)	1600	1600	1643
E: Max Digging Radius (mm)	3947	3947	3891
F: Ground Max Digging Radius(mm)	3889	3889	3835
G: Min Swing Radius (mm)	1625	1575	1575
H: Max Blade Height (mm)	405	405	405
I: Max Blade Depth(mm)	86	86	86