



Applicable models: XN10-8

Technical parameters		Unit	
Operating weight		kg	1010
Bucket capacity		m ³	0.02
Type of working device			Backhoe
Engine	Model		Koop 192
	Displacement	L	0.499
	Rated output power/speed	kw/r/min	7.6/3000
	Maximum torque/rotating speed	N.m/r/min	25/2860
Speed	Maximum traveling speed (High/low)	km/h	1.3
	Slewing speed	rpm	11
	Maximum grade ability		30%
Tracks	Ground pressure	k Pa	30.95
	Material		Rubber
	Tension control type		Tightening cylinder
Hydraulic pump	Type		gear pump
	Working pressure	Mpa	16
	Flow	(L/min)	19.5
Tank capacity	Hydraulic oil tank capacity	(L)	16
	Fuel tank capacity	(L)	11

All ratings of the machine are obtained when the machine is operating on a solid horizontal support surface. If the working environment conditions of the machine differ from the above-mentioned reference conditions (Such as the operations on uneven ground and slope), the operator shall take these conditions into consideration.



Applicable models: XN10-8

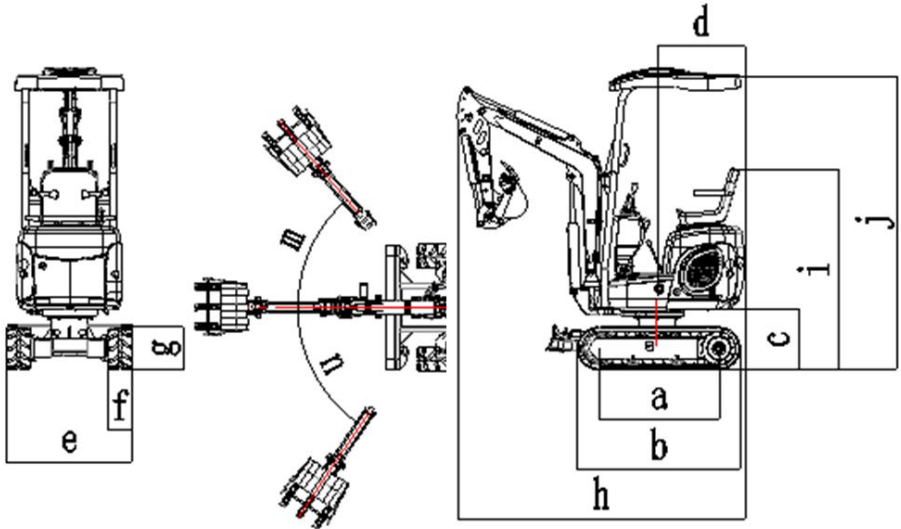

	Overall dimensions	Unit: mm
a	Wheel track	910
b	Overall length of crawler	1235
c	Ground clearance of platform	460
d	Tail slewing radius of platform	660
e	Chassis width	800-950
f	Track width	180
g	Track height	320
h	Transport length	2170/2850
i	Ground clearance of seat	1520
j	Overall height	2195
m	Boom slewing - right	50°
n	Boom slewing – left	55°



Applicable models: XN10-8

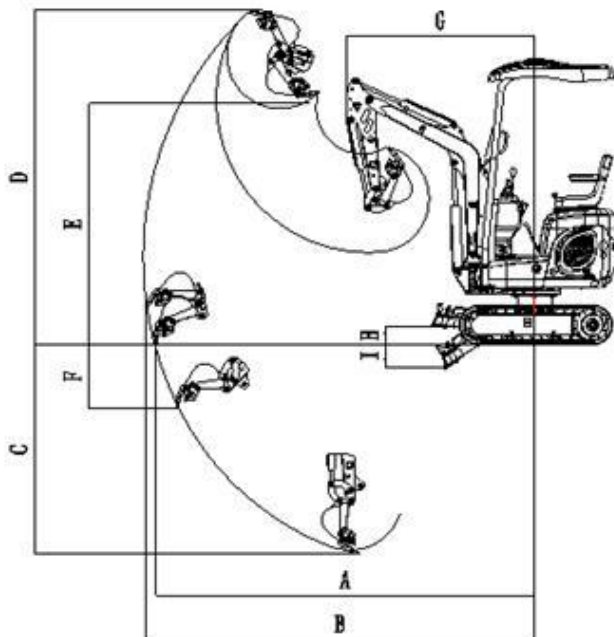

	Working range	Unit: mm
A	Ground maximum digging radius	3040
B	Maximum digging radius	3135
C	Maximum digging depth	1580
D	Maximum digging height	2620
E	Maximum Dump height	2000
F	Maximum vertical digging depth	1580
G	Minimum slewing radius	1510
H	Maximum lifting height of bulldozing blade	140
I	Maximum digging depth of bulldozing blade	200



Parameters
Lifting power

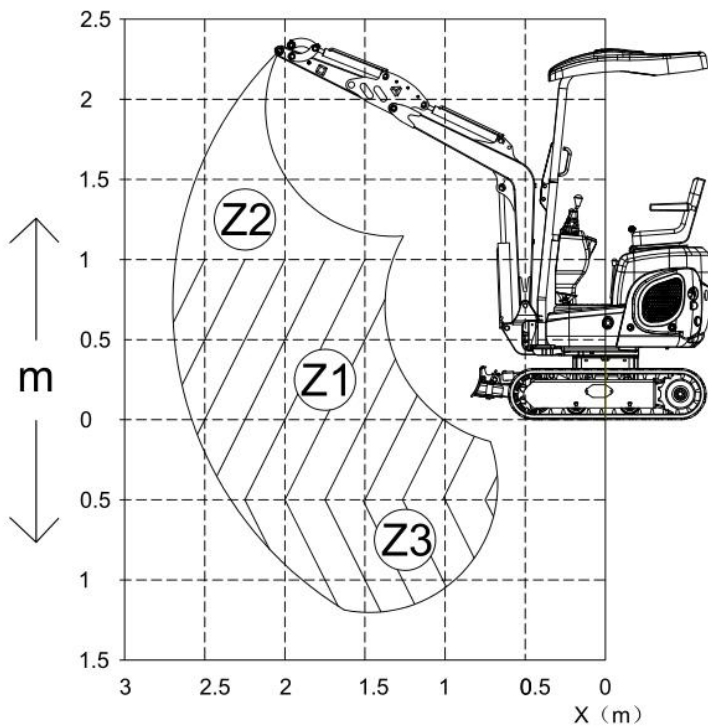

XN10-8					kg
	1m	1.5m	2m	2.5m	MAX
Z2	—	285	245	275	—
Z1	495	415	335	245	265
Z3	525	355	275	—	—