

Shop Managers
Carpenters
Acrylic Specialists
CNC Specialists
Welders
Painters
Lighting Experts
Audiovisual Experts
Warehouse Managers
Rental Managers
Shipping Specialists
Accredited Fork Truck Drivers
Truck Drivers
Carpeting Specialists
and more...

\$425 billion is spent annually by exhibitors in the U.S.

\$1.7 million companies exhibit at business events each year

13,000+ trade shows take place in the U.S. every single year

450+ students have been paired with industry professionals

**We are America's small businesses
supporting America's small businesses!**

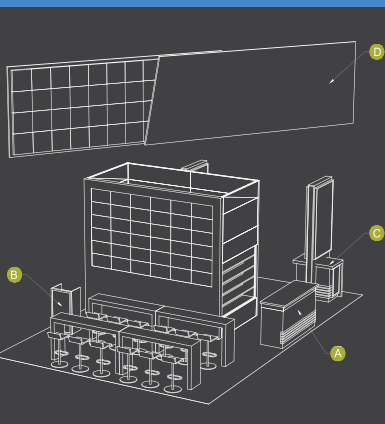

Kyle
Area Manager
NUVISTA
Southern California



What do you do?

I'm a tradeshow City Manager, where I partner with clients and crew to create and build exhibits for events ranging from auto shows to music industry conventions to medical conferences and everything in between.

What's your favorite part about the Industry?

My favorite part of the tradeshow industry is that my work days are always different. Each show I work at is unique, from a small, private event in a hotel ballroom to a giant exhibit hall in a convention center. I also have the opportunity to meet and work with talented, hardworking people.

If you could give your younger self advice, what would it be?

I would tell myself to be more curious about all kinds of professions and careers. I would network early and genuinely, because I've learned that relationships open more doors than resumes alone.



Shop Managers
Carpenters
Acrylic Specialists
CNC Specialists
Welders
Painters
Lighting Experts
Audiovisual Experts
Warehouse Managers
Rental Managers
Shipping Specialists
Accredited Fork Truck Drivers
Truck Drivers
Carpeting Specialists
and more...

\$425 billion is spent annually by exhibitors in the U.S.

\$1.7 million companies exhibit at business events each year

13,000+ trade shows take place in the U.S. every single year

450+ students have been paired with industry professionals

**We are America's small businesses
supporting America's small businesses!**

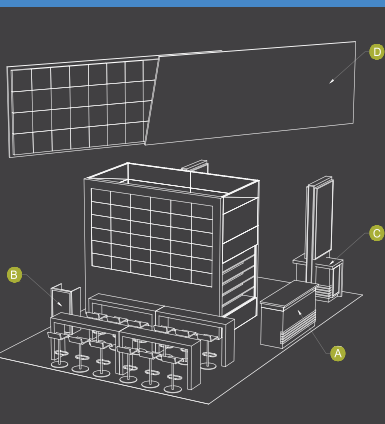

Tim
Carpenter
*Bluehive
Massachusetts*

What do you do?

I'm an exhibit builder. I work with power and hand tools to construct exhibit components, handling materials like wood and plywood, plexiglass and aluminum. My workday varies. Sometimes I'm reading and interpreting blueprints, other days I'm doing finishing work like sanding and laminating. I do pretty much anything you can think of that has to do with assembling parts and putting an exhibit together, from building panels and walls to cabinets and desks, custom kiosks, hanging signs, display cases and shelving and a lot more.

What's your favorite part about the Industry?

Every day is different. I'm never building the same thing twice. I enjoy being challenged and being able to apply my learning and skills across a variety of projects.

If you could give your younger self advice, what would it be?

To relax and enjoy the moment more.

