

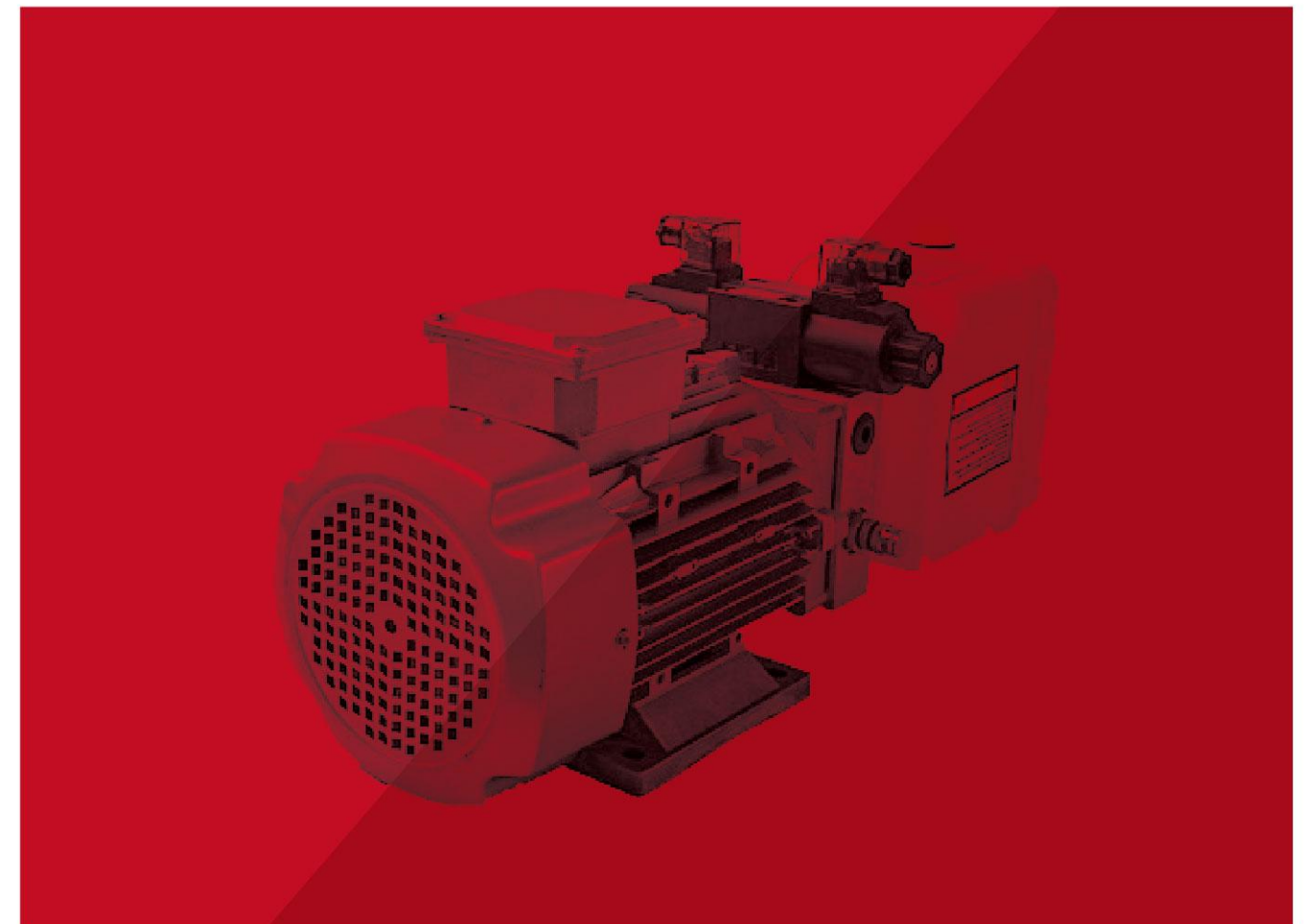

POWER UNITS

Variety and Customization



SHANGHAI RYAN FLUID POWER CO.,LTD

Address: Rm 1703-2, 33#, 1228 Jiangchang Rd, Shanghai, China

Tel: +86-21-56626882

Email: sales@ryanhydraulic.com

Website: www.ryanhydraulic.com

Zip code: 200434



RYAN HYDRAULICS

Keep the concept seeking excellence, Ryan try our best to create more value for you with products and service.

Ryan Hydraulics

Supplier of the Whole Hydraulic System

Ryan Hydraulics manufacture was established in 1986, focusing on R&D, manufacture and sales of hydraulic products. Ryan Hydraulics owns world top level R&D team, as well as invention patents, sales covers global market. Targeting at vision of Excellence, Ryan Hydraulics keeps creating more value for customers by quality products, professional technology and experienced service.

645,835 sq.ft Modern Manufacture

Since the opening of 3rd generation modern manufacture in 2015, the total area covers 1,291,669 sq.ft, while the construction area covers 645,835 sq.ft, there are IT machining equipment, test and inspection equipment, meets various requirement of global customers.

Customer First

With leading technology, quality product, and professional service, Ryan Hydraulics has covered the global market with more than 60 countries and regions, become the strategic partner of many international famous OEM enterprises.

Instant Efficient Service

Technical Team offers accurate solutions to the service, including the product model selection, product test, installation and commissioning, debugging etc., so as to keep in touch with right department of each customer in time and respond to the customer's requirement.



9 Series Products Covers the Whole Hydraulic Business

As a supplier of hydraulics, our business covers: hydraulic motors, hydraulic control valves, hydraulic gear pumps, power units and hydraulic systems, etc. Products are widely used in construction machinery, agricultural machinery, industry equipment.



Contents

Ryan Power Units

For Vehicle Lift	02	
	03	For Hydraulic Scissors Lift
For Aerial Work Platform	04	
	05	For Semi-electric Stacker
For All-electric Stacker	06	
	07	For Van Truck
For Automobile Tail Gate	08	
	09	For Tyre Press
For Dock Leveler	10	
	11	For Snow Removal Truck
For Pallet Truck	12	
	13	For Medical Equipment
Ordering Code	14	
	15-20	Hydraulic Schematics

Power Unit for Vehicle Lift

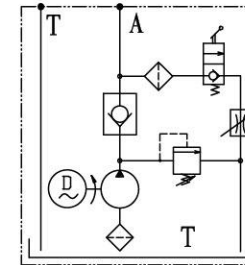

This hydraulic power unit is made up of high pressure gear pump, AC motor, multi-manifold hydraulic valve, oil tank, etc. It enables the two post vehicle lift have the function of lift and fall. The throttle valve can control fall speed.

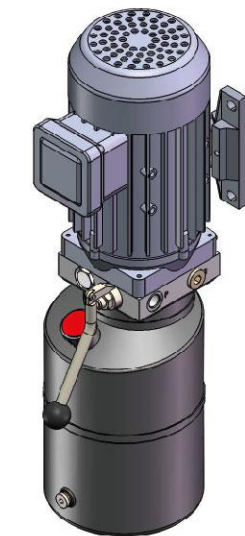
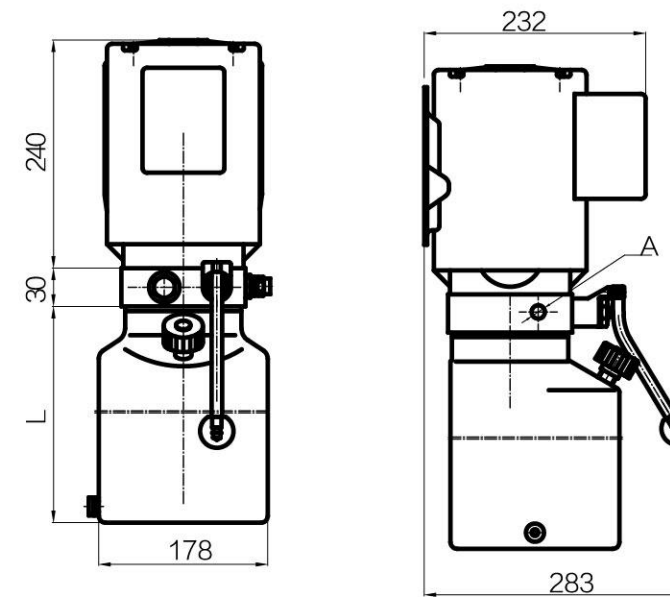

Specifications

Model	Motor	Disp. (cc/r)	Tank Cap. (L)	Pressure (MPa)	Installation	Port Size	L(mm)
AC-F5-2.1/F-2.2/220/2850/**-10V-D	220V 2.2Kw 2850RPM 50Hz	2.1	10	20	Vertical	G3/8	440
AC-F5-2.7/F-2.2/220/2850/**-12V-D		2.7	12	18			545
AC-F5-2.1/F-2.2/380/2850/**-10V-D	380V 2.2Kw 2850RPM 50Hz	2.1	10	20			440
AC-F5-2.7/F-2.2/380/2850/**-12V-D		2.7	12	18			545

Specific parameters can be customized according to customer requirements.

Power Unit for Scissors Lift

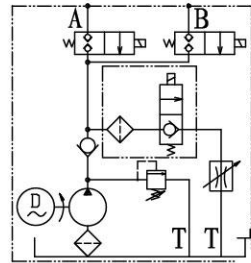

This power unit use no-leak dual way check valve to realize the complete isolation of two lines. It makes this two lines totally independent in the action of lift and fall. It is the ideal hydraulic power for multiple cylinder single lift system. This power unit widely used in primary and big scissors lift.

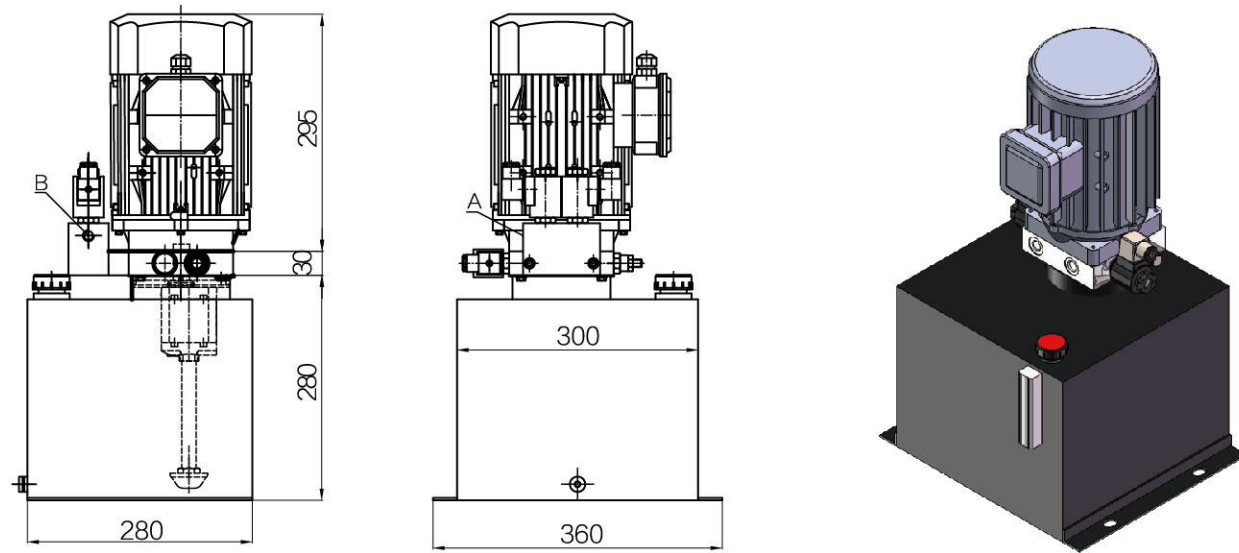

Specifications

Model	Motor	Disp. (cc/r)	Tank Cap. (L)	Pressure (MPa)	Installation	Port Size
AC-F29-2.1/F-2.2/220/2850/**-20V-C	220V 2.2Kw 2850RPM 50Hz	2.1	20	20	Vertical	G1/4
AC-F29-2.1/H-3.0/220/2850/**-20V-C	220V 3.0Kw 2850RPM 50Hz			26		
AC-F29-2.1/G-2.2/380/2850/**-20V-C	380V 2.2Kw 2850RPM 50Hz			22		
AC-F29-2.1/H-3.0/380/2850/**-20V-C	380V 3.0Kw 2850RPM 50Hz			28		

Specific parameters can be customized according to customer requirements.

Power Unit for Aerial Work Platform

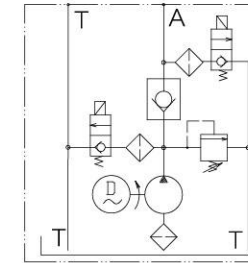

This power unit is made up of high pressure gear pump, AC motor, multi-manifold, hydraulic valve, oil tank, etc. It provides the lift and fall function for aerial work platforms. With double electric valves, this power unit is able to start without load.

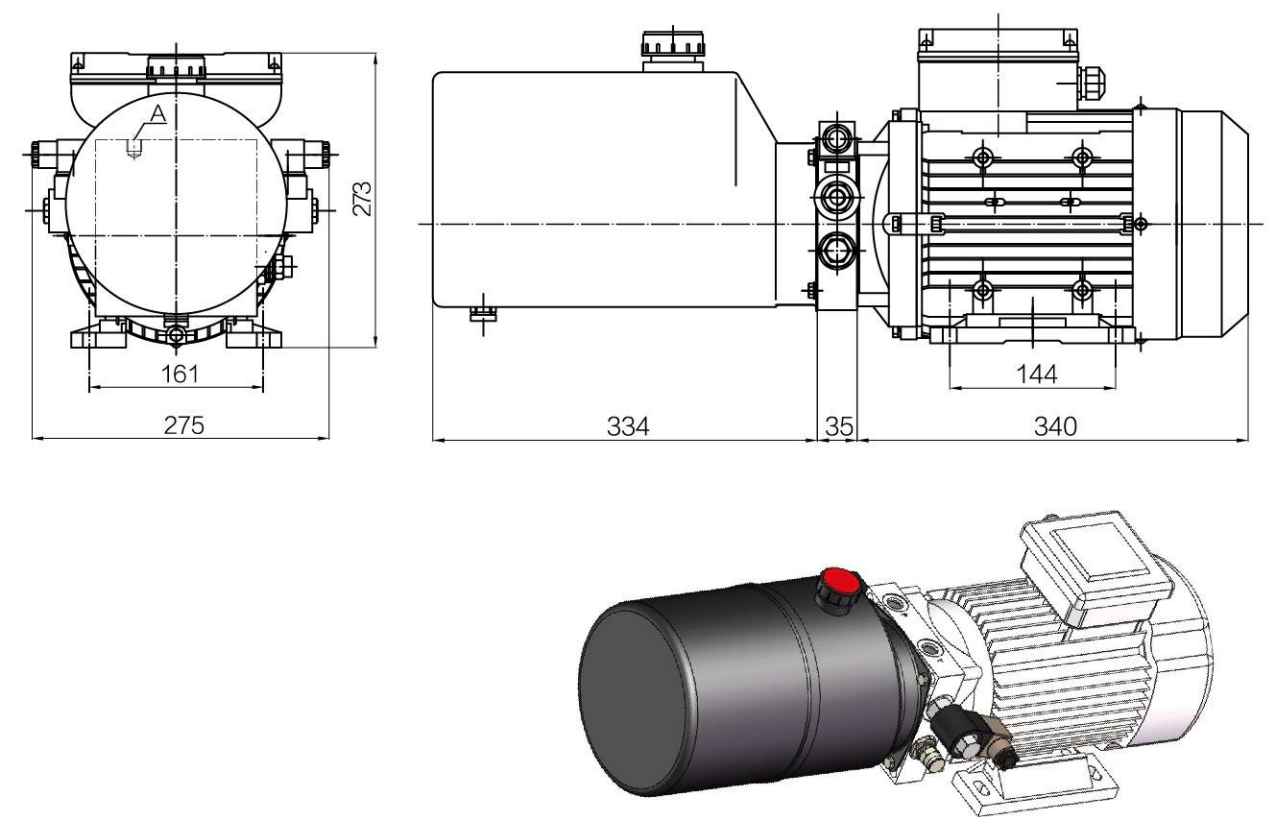

Specifications

Model	Motor	Disp. (cc/r)	Tank Cap. (L)	Pressure (MPa)	Installation	Port Size
AC-F11-1.1/F-1.5/220/2850/**-6H-C	220V 1.5Kw 2850RPM 50Hz	1.1	6	18	Horizontal	G1/4

Specific parameters can be customized according to customer requirements.

Power Unit for Semi-electric Stacker

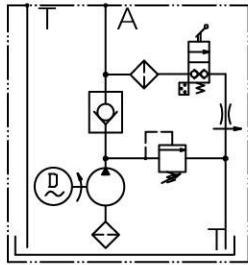

This power unit is specially designed for stackers. It is made up of high pressure gear pump, AC motor, multi-manifold, hydraulic valve, oil tank, etc. There is micro switch on manual unloading valve. The lift and fall action of stacker is controlled by handle of unloading valve. Fall speed is automatically controlled by built-in pressure compensated throttle valve.

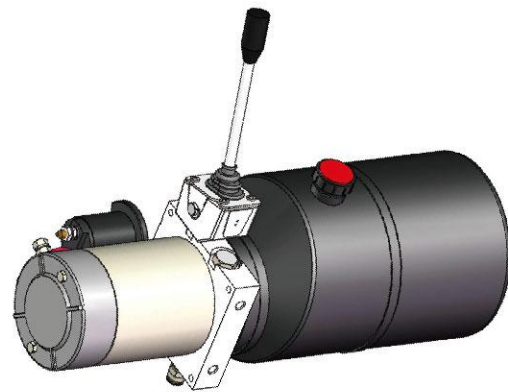
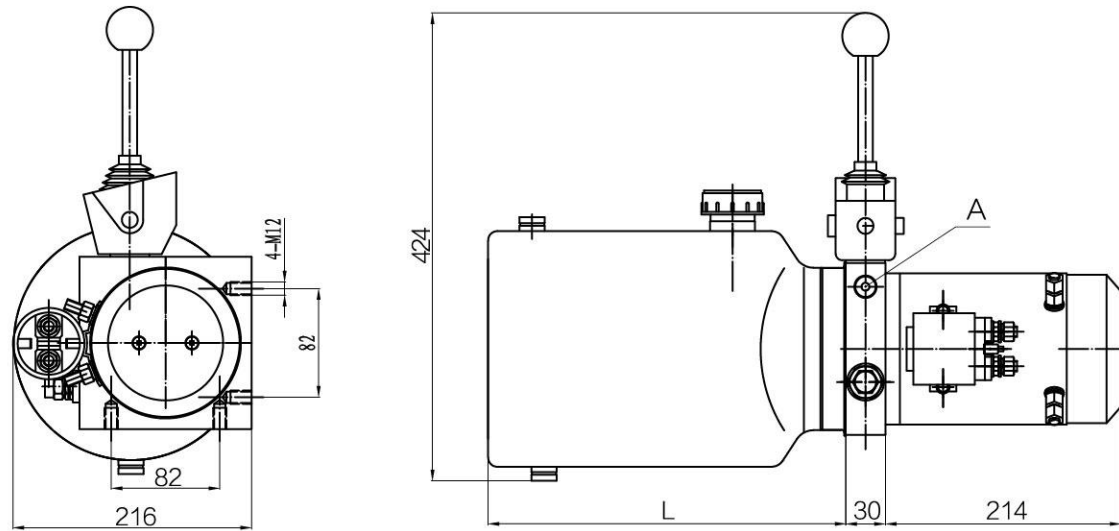

Specifications

Model	Motor	Disp. (cc/r)	Tank Cap. (L)	Pressure (MPa)	Installation	Port Size	L(mm)
DC-F6-1.6/F-1.6/12/**-5HS-D	12V 1.6Kw 2500RPM	1.6	5	20	Horizontal	G3/8	270
DC-F6-2.1/F-1.6/12/**-6HS-D		2.1	6				300
DC-F6-2.1/F-2.2/24/**-6HS-D	24V 2.2Kw 2500RPM	2.1	6				300
DC-F6-2.6/F-2.2/24/**-8HS-D		2.6	8				370

Specific parameters can be customized according to customer requirements.

Power Unit for All-electric Stacker

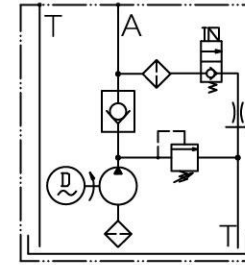

This hydraulic power unit is made up of high pressure gear pump, AC motor, multi-manifold, hydraulic valve, oil tank, etc. It is a typical power up, gravity down hydraulic circuits. Start the motor, it rises. Open electromagnetic unloading valve, it drop. Falling speed automatic controlled by the built-in pressure compensated flow control valve. This series is ideal power supplier for logistics facilities, such as all sorts of fork truck, small lift platform etc.

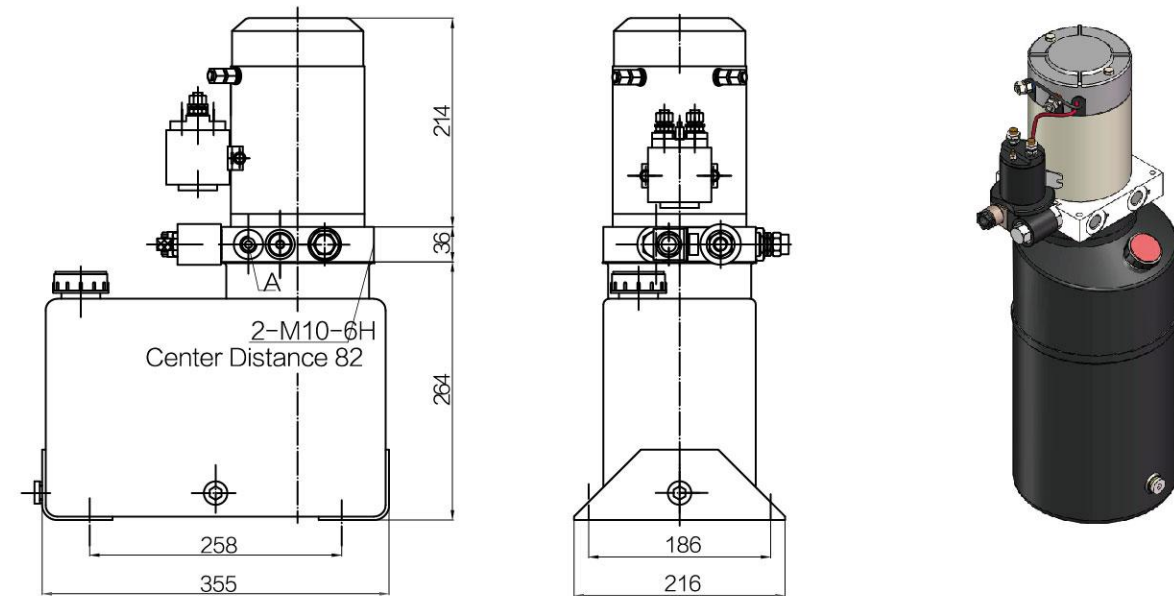

Specifications

Model	Motor	Disp. (cc/r)	Tank Cap. (L)	Pressure (MPa)	Installation	Port Size
DC-F10S-1.6/F-1.6/12/**-7V-D	12V 1.6Kw 2500RPM	1.6	7	20	Vertical	G3/8
DC-F10S-2.6/F-2.2/24/**-7V-D	24V 2.2Kw 2500RPM	2.6				

Specific parameters can be customized according to customer requirements.

Power Unit for Van Truck

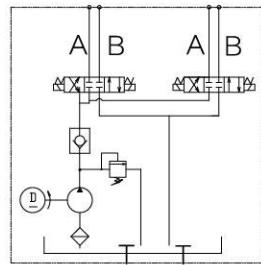

This hydraulic power unit is made up of high pressure gear pump, AC motor, multi-manifold, hydraulic valve, oil tank, etc. It permits usage for four double action tank, provide wing opening function for van truck.

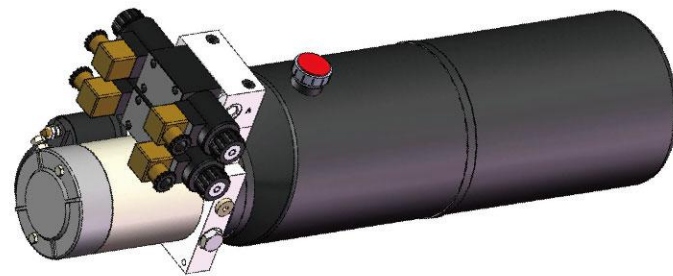
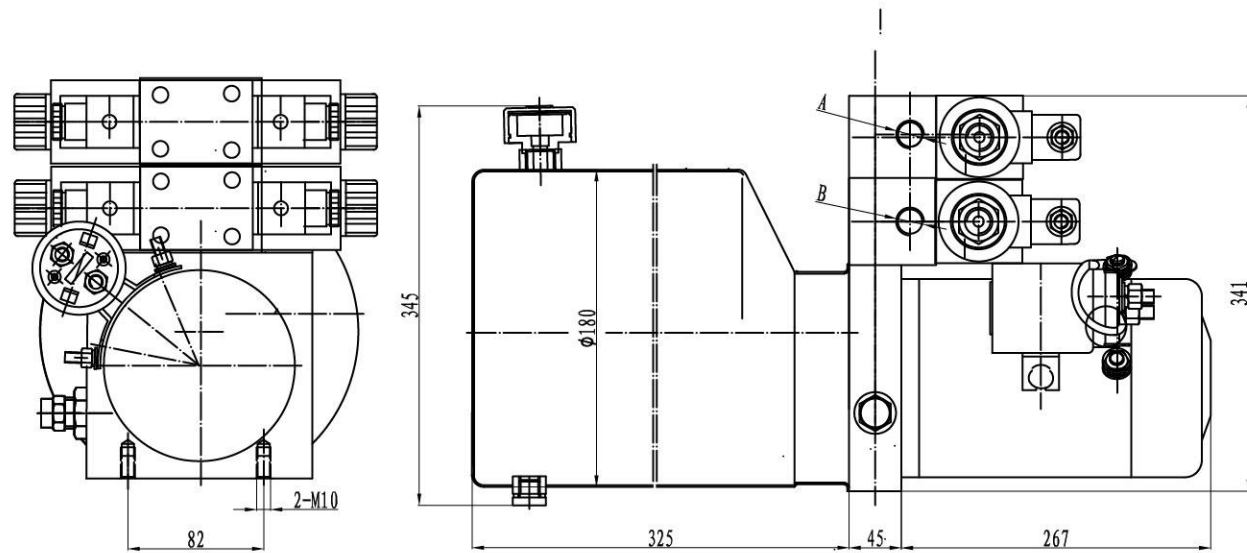

Specifications

Model	Motor	Disp. (cc/r)	Tank Cap. (L)	Pressure (MPa)	Installation	Port Size
DC-F39-2.5/E-2/24/**-8H-A	24V 2Kw 2850RPM 50Hz	2.5	8	14	Horizontal	M14×1.5

Specific parameters can be customized according to customer requirements.

Power Unit for Automobile Tail Gate

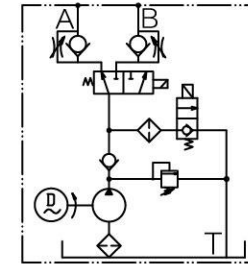

This hydraulic power unit is made up of high pressure gear pump, AC motor, multi-manifold, hydraulic valve, oil tank, etc. It provides lift, down, open and close function for automobile tail gate, box type combination is convenient for transportation installation.

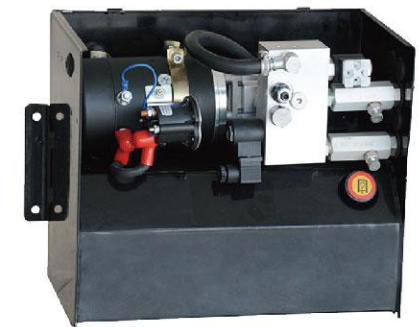
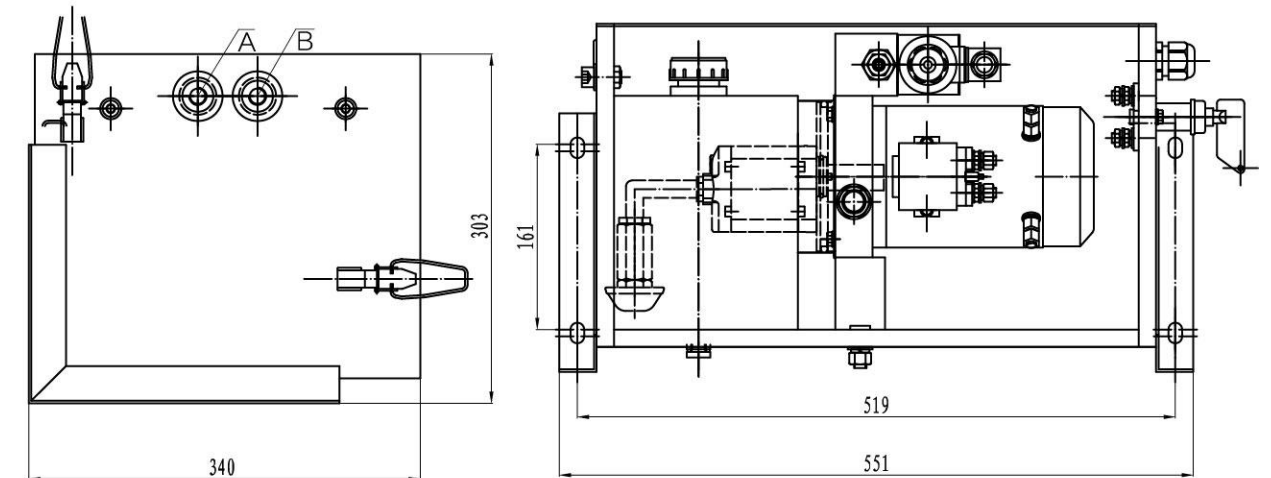

Specifications

Model	Motor	Disp. (cc/r)	Tank Cap. (L)	Pressure (MPa)	Installation	Port Size
DC-F15-2.1/F-2.0/12/**-9H-A	12V 2.0Kw 2500RPM	2.1	9	20	Horizontal	M14×1.5
DC-F15-2.1/F-2.2/24/**-9H-A	24V 2.2Kw 2500RPM					

Specific parameters can be customized according to customer requirements.

Power Unit for Tyre Press

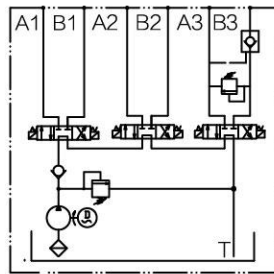

This hydraulic power unit is made up of high pressure gear pump, AC motor, multi-manifold, hydraulic valve, oil tank, etc. It is designed for tyre press, controlling three sets of double-acting cylinder.

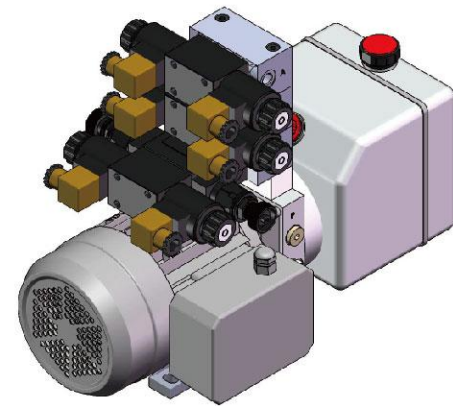
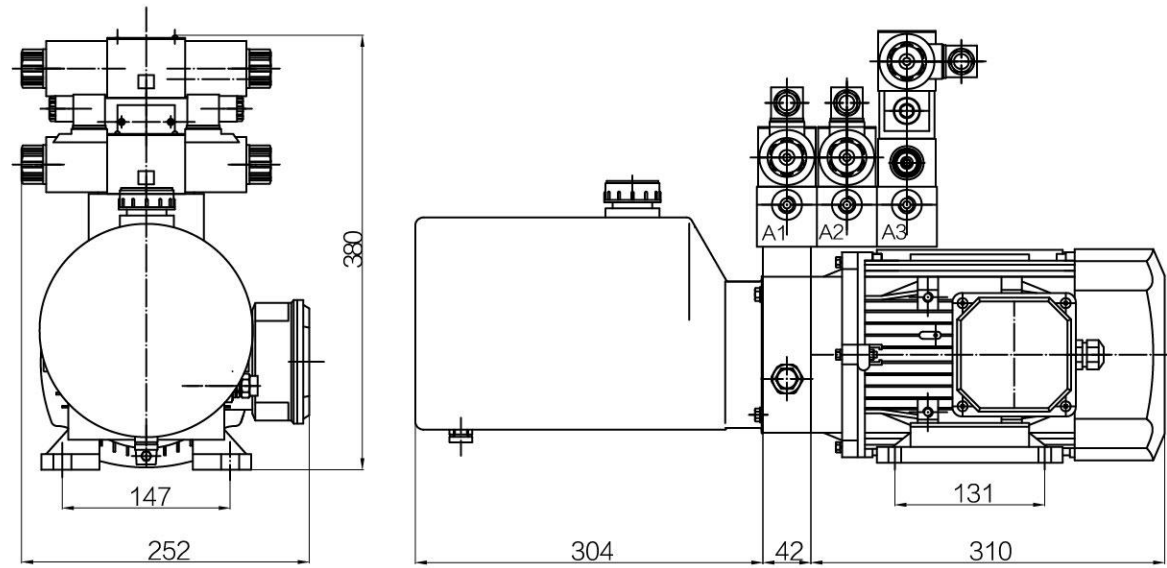

Specifications

Model	Motor	Disp. (cc/r)	Tank Cap. (L)	Pressure (MPa)	Installation	Port Size
AC-F40-3.2/F-1.5/380/1450/**-6H-C	380V 1.5Kw 1450RPM 50Hz	3.2	6	18	Horizontal	G1/4
AC-F40-4.2/F-2.2/380/1450/**-6H-C	380V 2.2Kw 1450RPM 50Hz	4.2		20		

Specific parameters can be customized according to customer requirements.

Power Unit for Dock Leveler

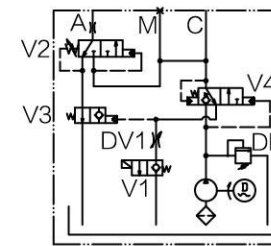

This hydraulic power unit is made up of high pressure gear pump, AC motor, multi-manifold hydraulic valve, oil tank, etc. It enables the dock leveler axle lift have the functions of making unequal-sized bridge plate lift, fall and close up. It could control two single-acting cylinder.

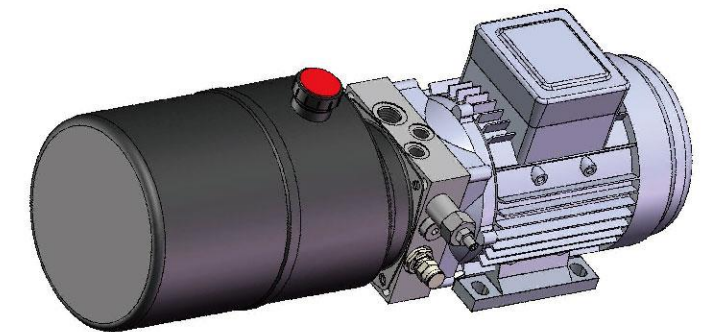
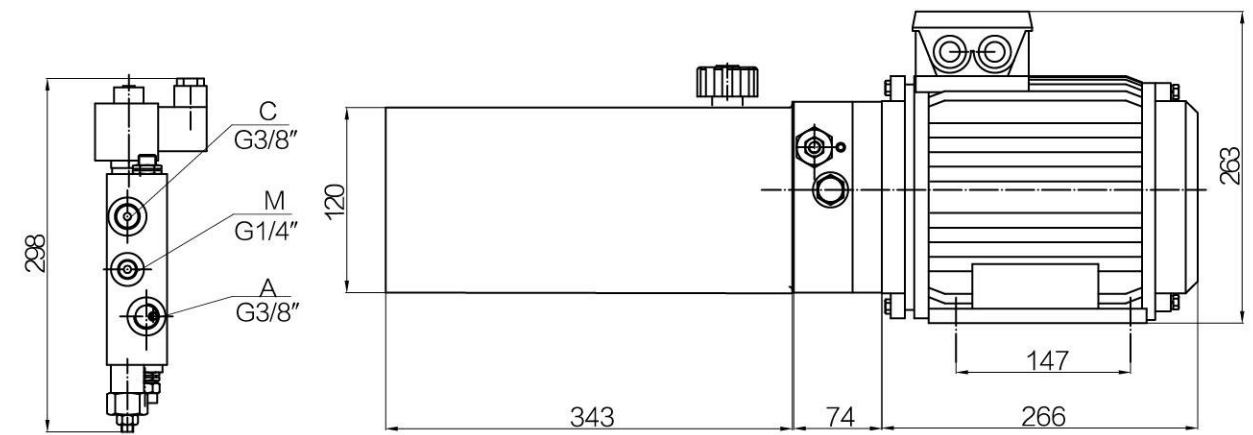

Specifications

Model	Motor	Disp. (cc/r)	Tank Cap. (L)	Pressure (MPa)	Installation	Port Size
AC-F32-3.2/E-1.5/380/1450/**-6H-C	380V 1.5Kw 1450RPM 50Hz	3.2	6	16	Horizontal	G1/4

Specific parameters can be customized according to customer requirements.

Power Unit for Snow Removal Truck

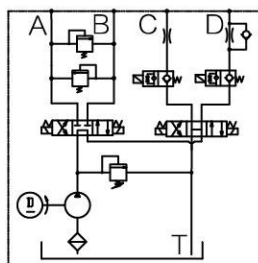

This hydraulic power unit is made up of high pressure gear pump, AC motor, multi-manifold, hydraulic valve, oil tank, etc. It enables the snow removal truck have the function of lift, fall and angle adjustment. This could control both the double-acting oil cylinder and single-acting cylinder in the same time.

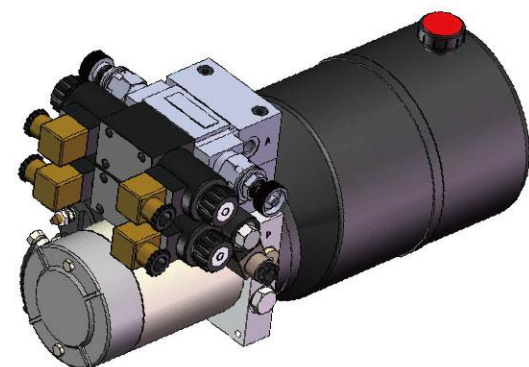
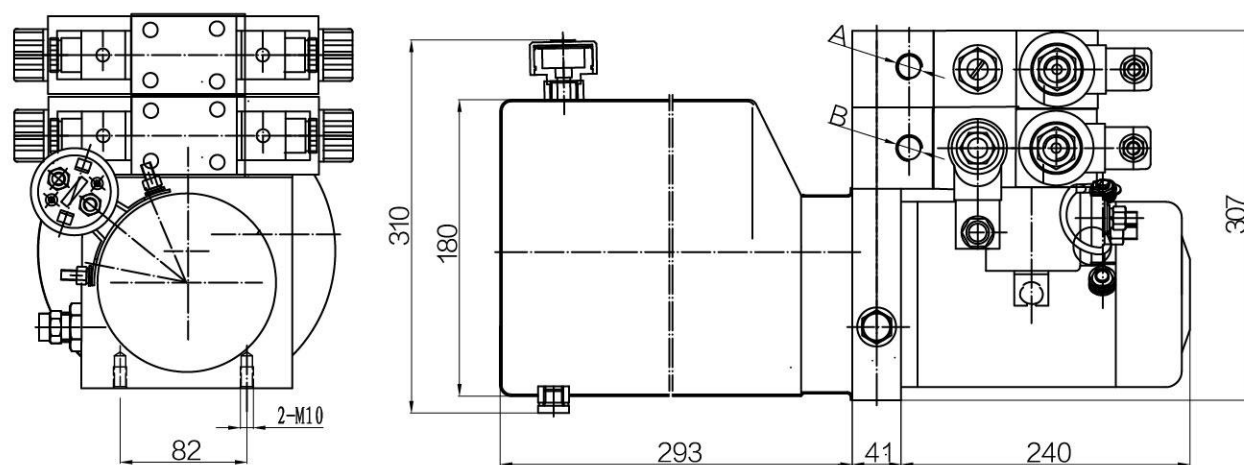

Specifications

Model	Motor	Disp. (cc/r)	Tank Cap. (L)	Pressure (MPa)	Installation	Port Size
DC-F36-1.6/F-1.6/12/**-5H-C	12V 1.6Kw 2500RPM	1.6	5	20	Horizontal	G1/4

Specific parameters can be customized according to customer requirements.

Power Unit for Pallet Truck

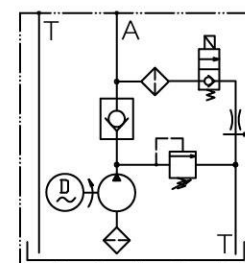

This hydraulic power unit is made up of high pressure gear pump, AC motor, multi-manifold, hydraulic valve, oil tank, etc. It used at the power origin of light fork truck and pallet truck. Electromagnetic unloading valve unloading to oil return, decline speed is controlled by pressure compensating flow control valve.

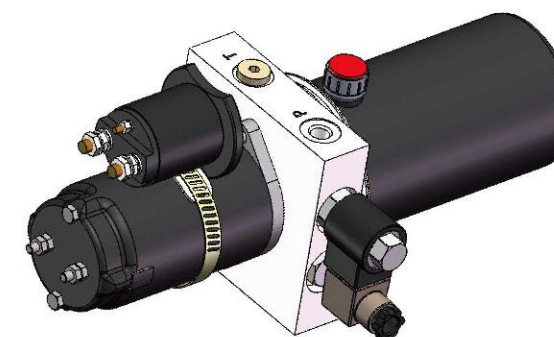
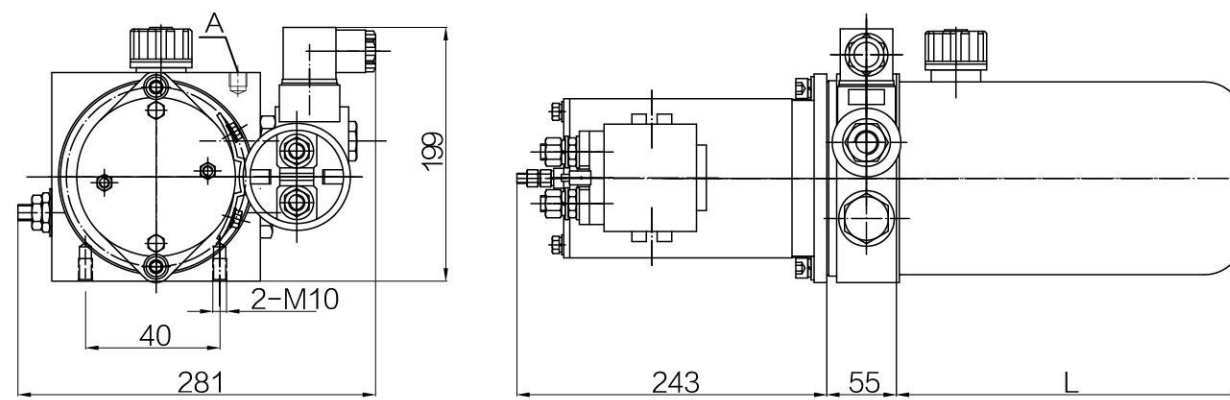

Specifications

Model	Motor	Disp. (cc/r)	Tank Cap. (L)	Pressure (MPa)	Installation	Port Size	L(mm)
DC-F10-0.50/E-0.8/12/**-1.0H-C	12V 0.8Kw 3450RPM 60Hz	0.50	1.0	16	Horizontal	G1/4	178
DC-F10-0.75/E-0.8/12/**-1.2H-C	12V 0.8Kw 3450RPM 60Hz	0.75	1.2				210
DC-F10-0.50/E-0.8/24/**-1.0H-C	24V 0.8Kw 3450RPM 60Hz	0.50	1.0				178
DC-F10-0.50/E-0.8/24/**-1.7H-C	24V 0.8Kw 3450RPM 60Hz	0.75	1.7				170

Specific parameters can be customized according to customer requirements.

Micro Power Unit for Medical Equipment

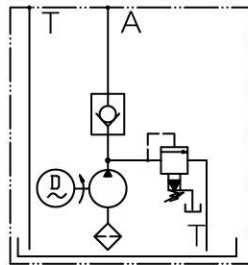

This hydraulic power unit is made up of motorized operating bed in medical equipment, low noise and electricity, light body, provide the power origin for operating bed, also used in electric bed.

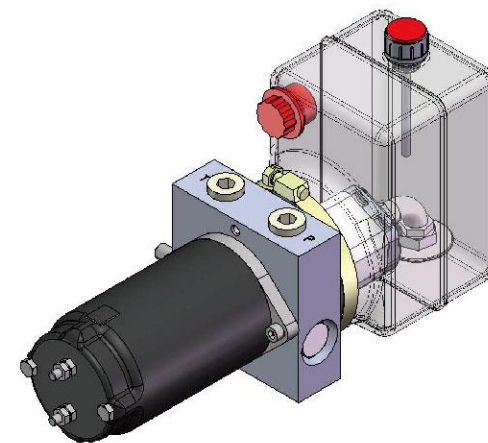
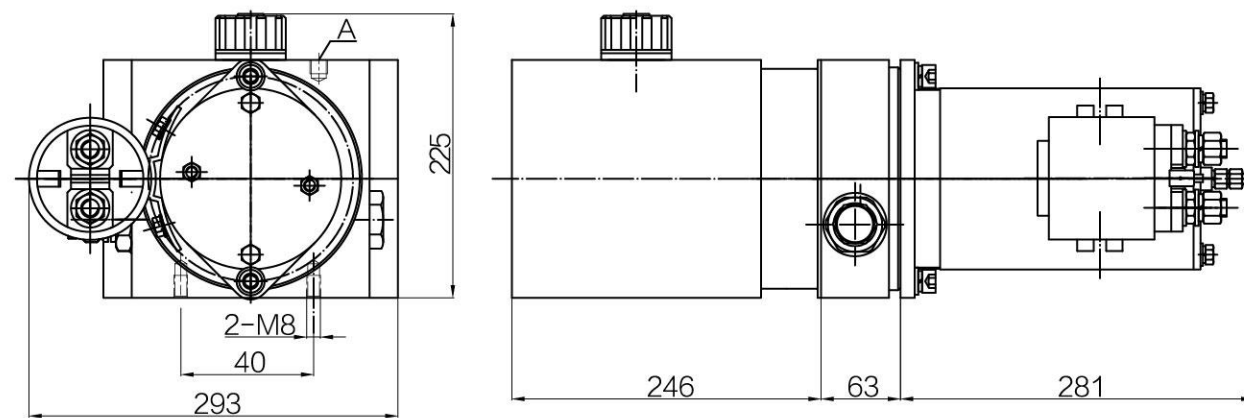

Specifications

Model	Motor	Disp. (cc/r)	Tank Cap. (L)	Pressure (MPa)	Installation	Port Size
DC-F02-0.25/D-0.5/24/**-1H-C	24V 0.5Kw 2000RPM	0.25	1.0	10	Horizontal	G1/4
DC-F02-0.50/D-0.5/24/**-1H-C		0.50		6.5		

Specific parameters can be customized according to customer requirements.

Ordering Code

DC-	F1-	2.5/	E-	2/	24/	**/	24-	8	*	H-	A
a	b	c	d	e	f	g	h	i	j	k	l

- Ⓐ Motor type
DC=DC motor
AC=Three-phase AC motor
A=Single-phase AC motor
- Ⓑ Hydraulic schematic
F01、F02、F03...
- Ⓒ Pump displacement(ml/r)
1.6、2、2.5、3、3.5、4、5...
- Ⓓ System pressure
D=100bar
E=160bar
F=200bar
G=250bar
H=315bar
- Ⓔ Motor power(kw)
0.5、0.8、1.5、1.6、2、2.1、2.2...
- Ⓜ Motor voltage(v)
12、24、220、380
- Ⓝ Motor speed(rpm)
1450、2000、2500、2850、3450
- Ⓢ Solenoid valve voltage(v)
12、24、220、380
- Ⓣ Tank capacity(L)
1、1.2、1.7、3、4、5、6、7、8、9、10、12、20...
- Ⓤ Tank material
P=Plastic
Omit=Iron
- Ⓚ Installation type
H=Horizontal
HS=Side horizontal
V=Vertical
T=Particular
- Ⓛ Port size
A=M14*1.5
B=M16*1.5
C=G1/4
D=G3/8
E=NPT3/8
F=9/16" SAE

Hydraulic Schematics

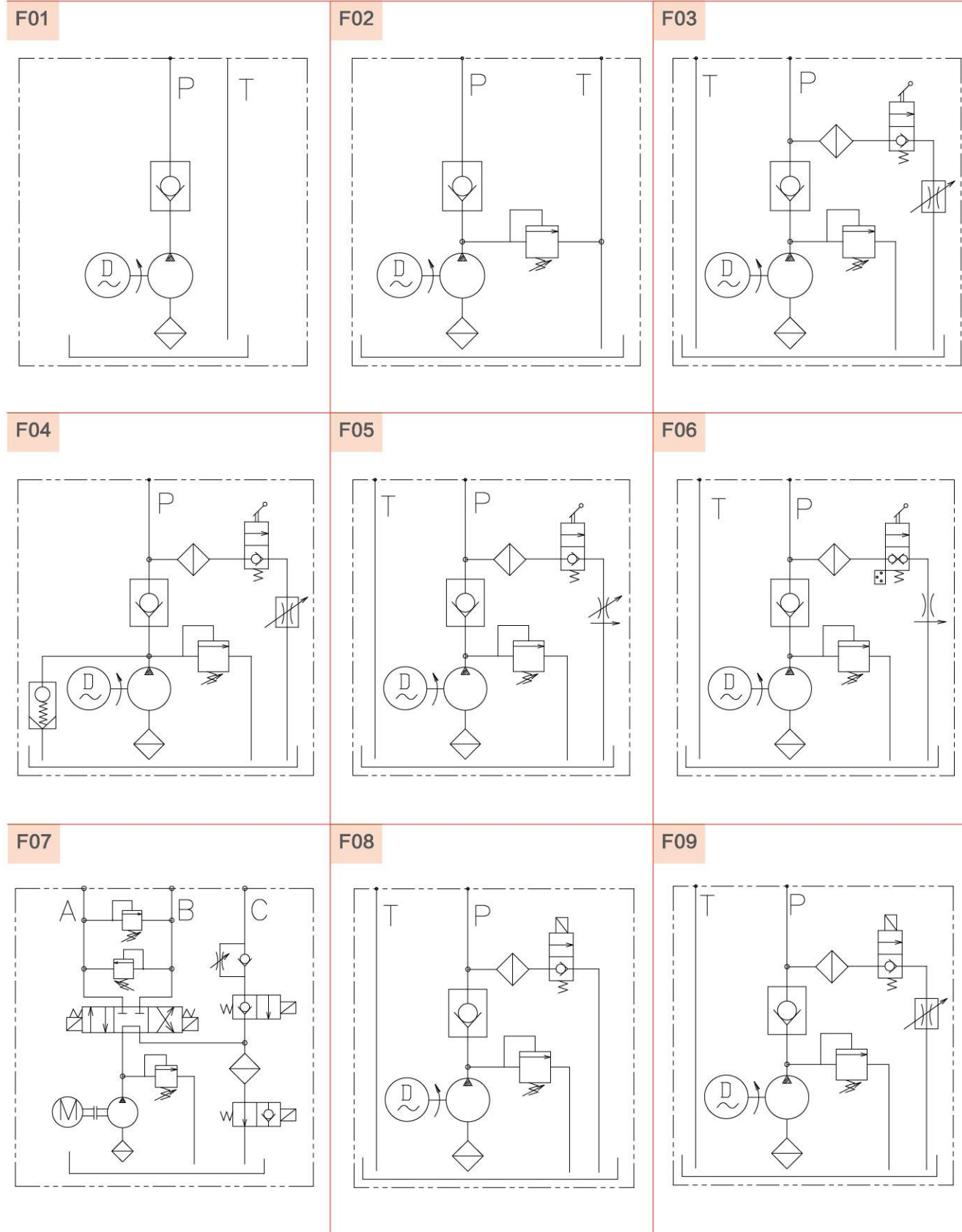

Hydraulic Schematics

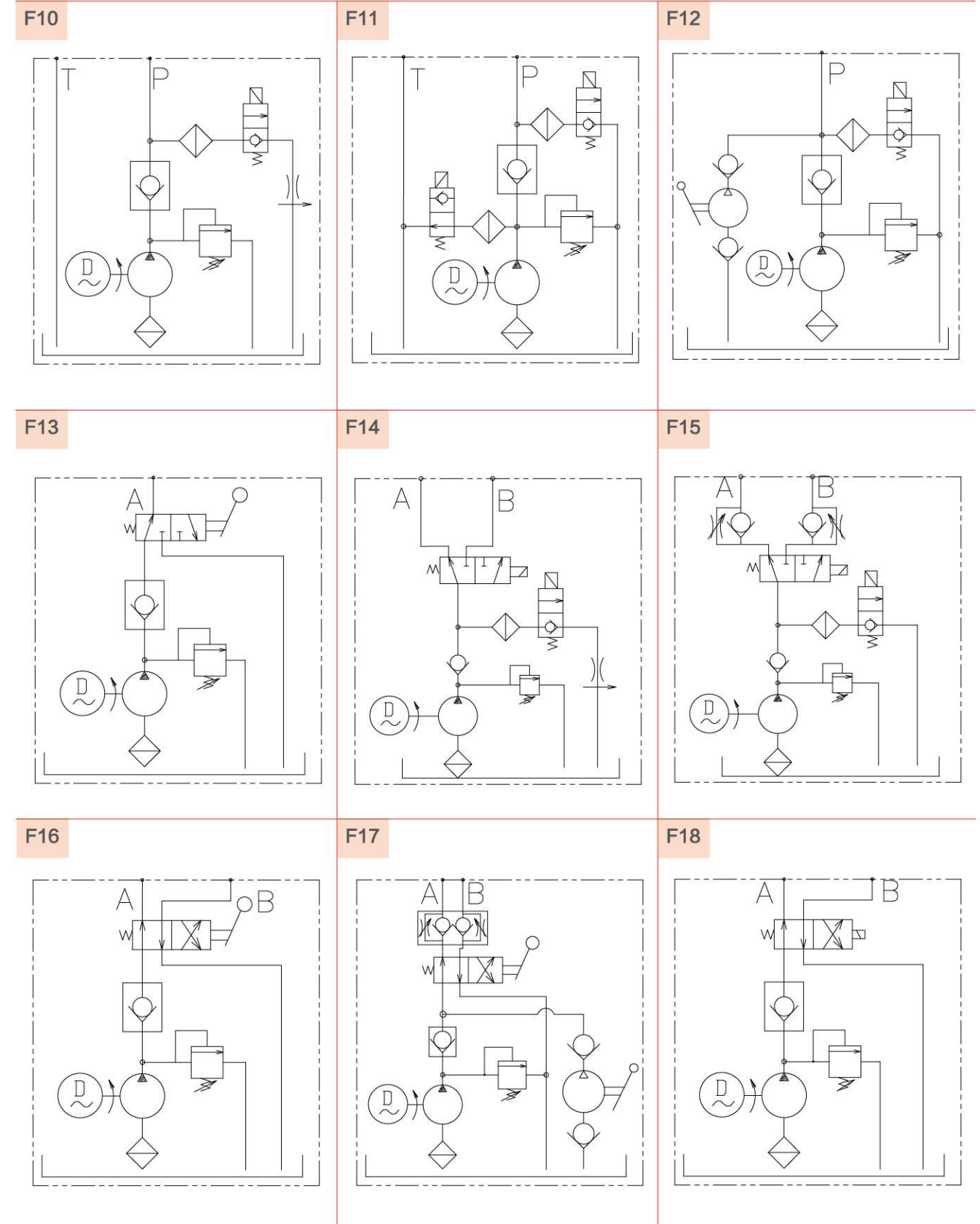

Hydraulic Schematics

F19

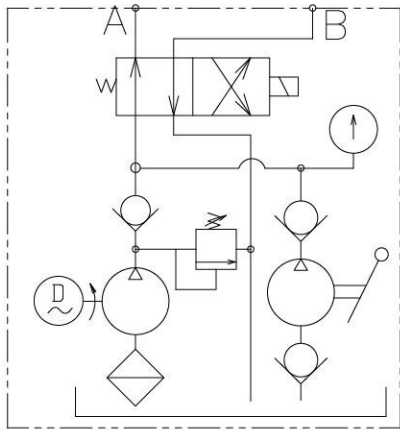

F20

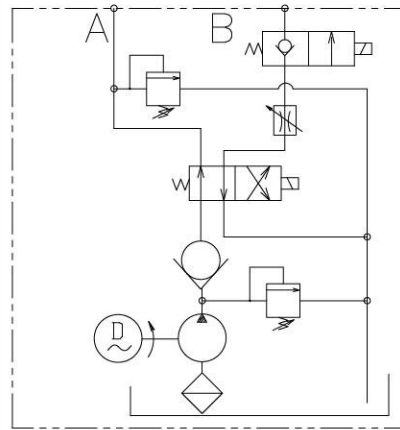

F21

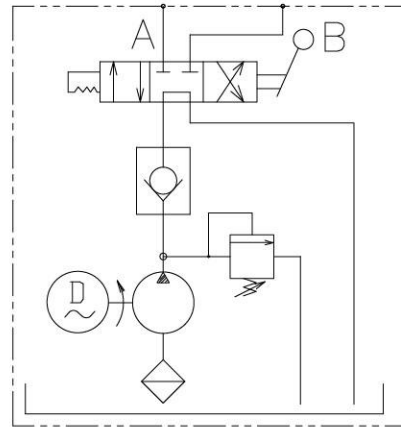

F22

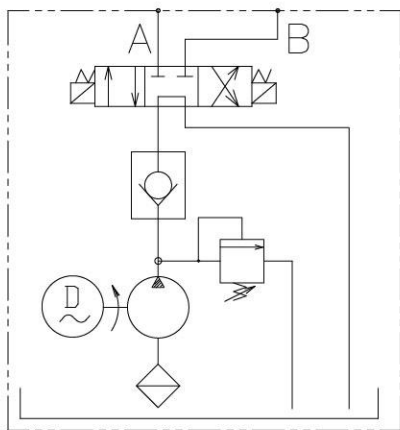

F23

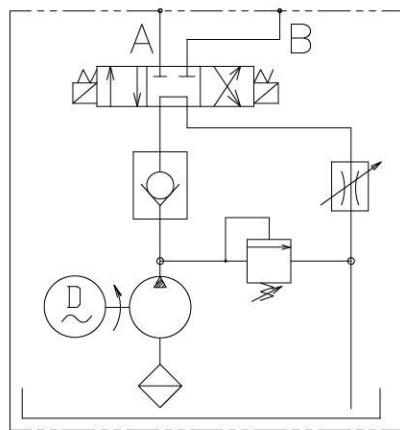

F24

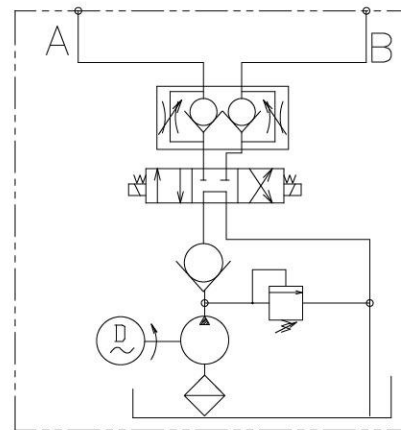

F25

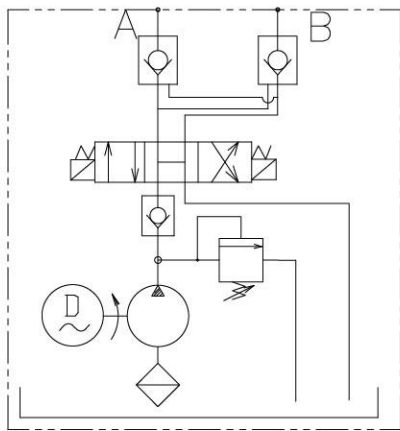

F26

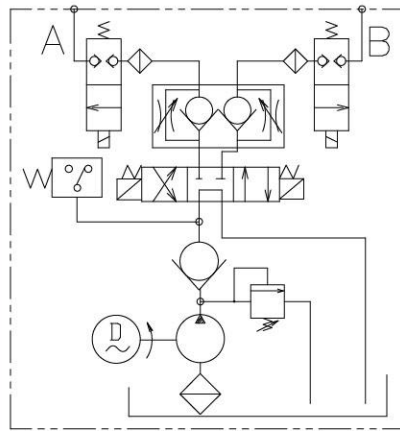

F27

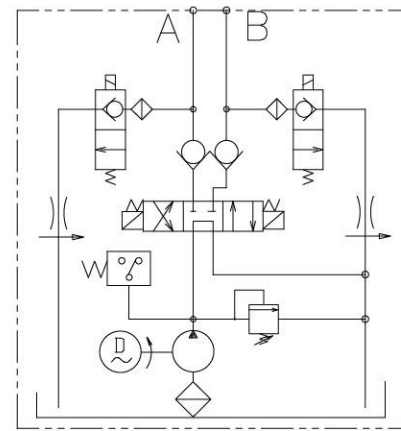

Hydraulic Schematics

F28

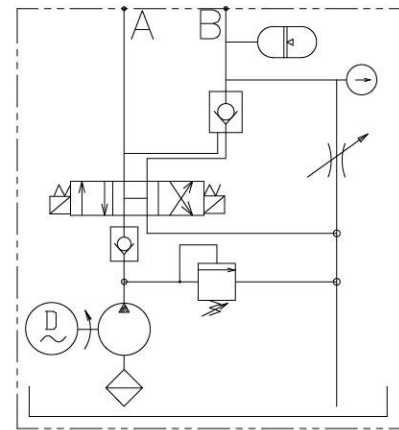

F29

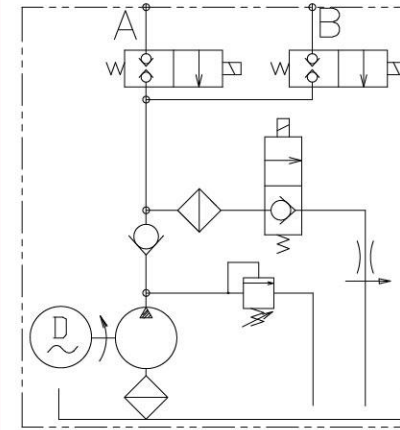

F30

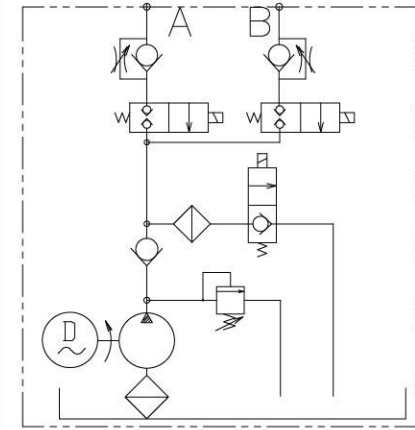

F31

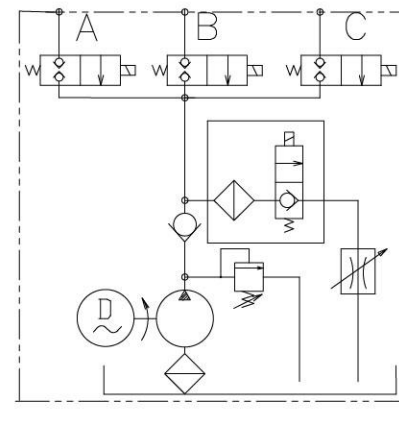

F32

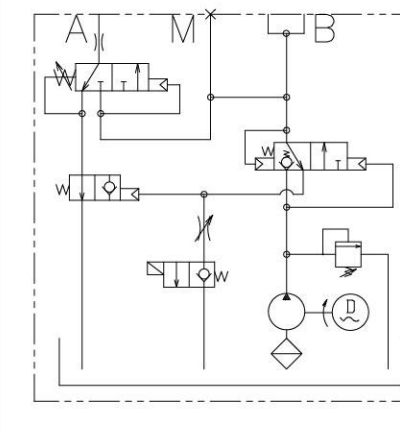

F33

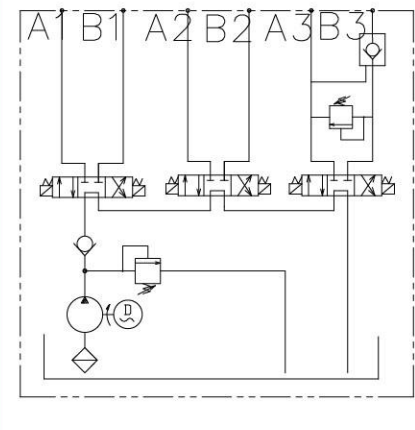

F34

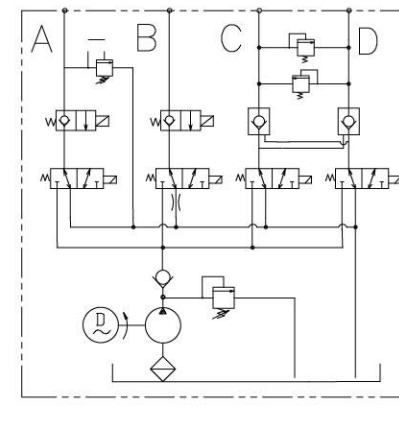

F35

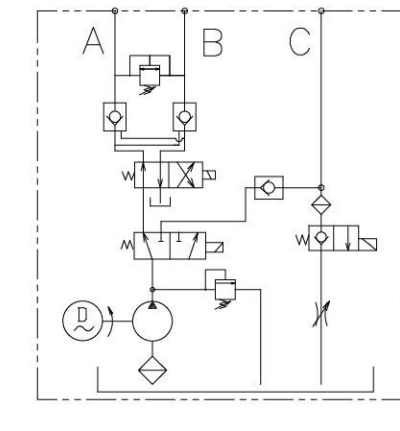

F36

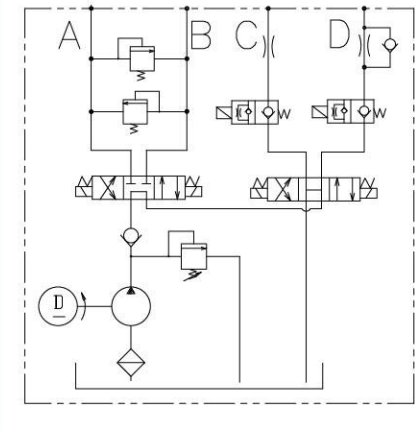

Hydraulic Schematics

F37

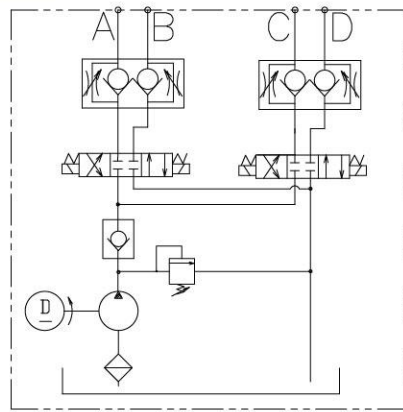

F38

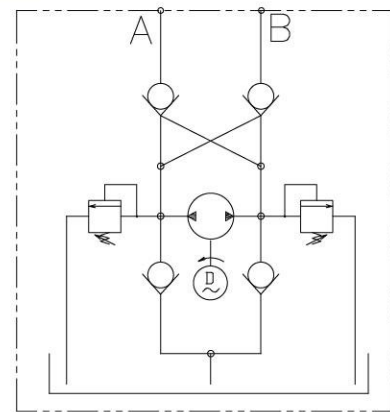

F39

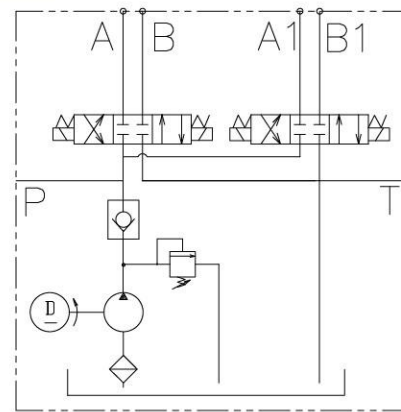

F40

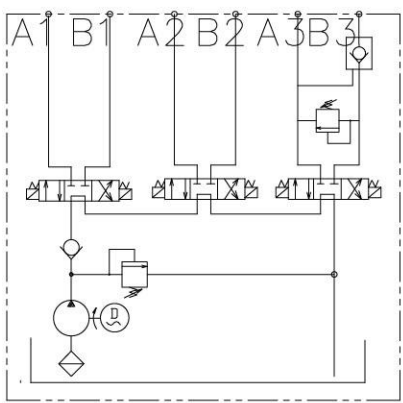

F41

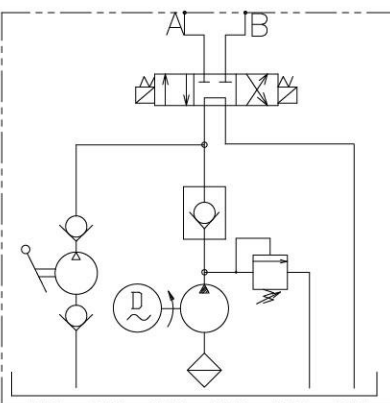

F42

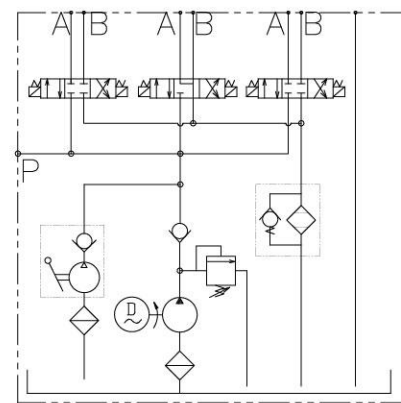

F43

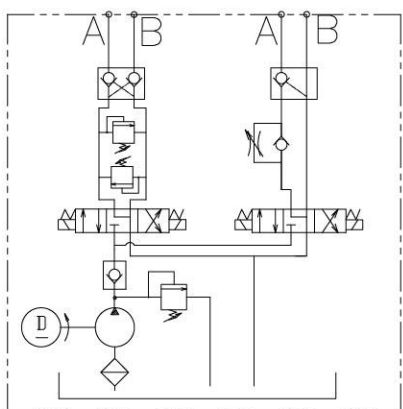

F44

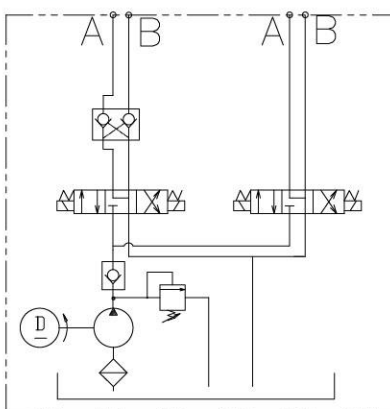

F45

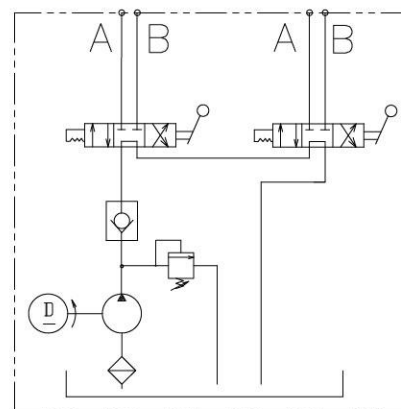

Hydraulic Schematics

F46

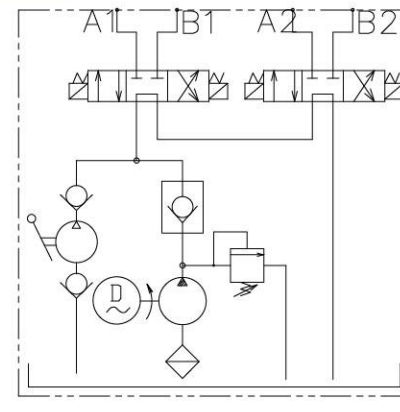

F47

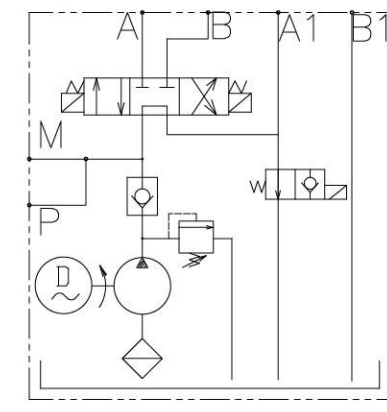

F48

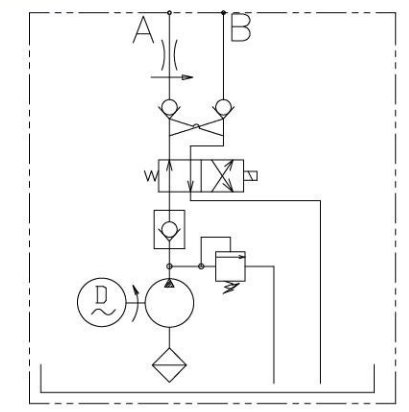

Notes

1. This duty of electric motor is S3, can not work continuously, can work intermittently.
2. Before installation, please be sure the cleanliness of component like tank, tube and fittings, without any impurities.
3. Viscosity of oil should be 15-68CST, should be clean and without impurities. Suggest to use N46 hydraulic oil.
If need to work all-weather, must use aviation hydraulic fluid.
4. This power unit is horizontal and vertical.
5. After first work, oil tank should be checked immediately to see if there is enough oil.
6. After the first 100 working hour, hydraulic oil should be replaced. After that, the oil should be replaced every 3000 working hours.

