

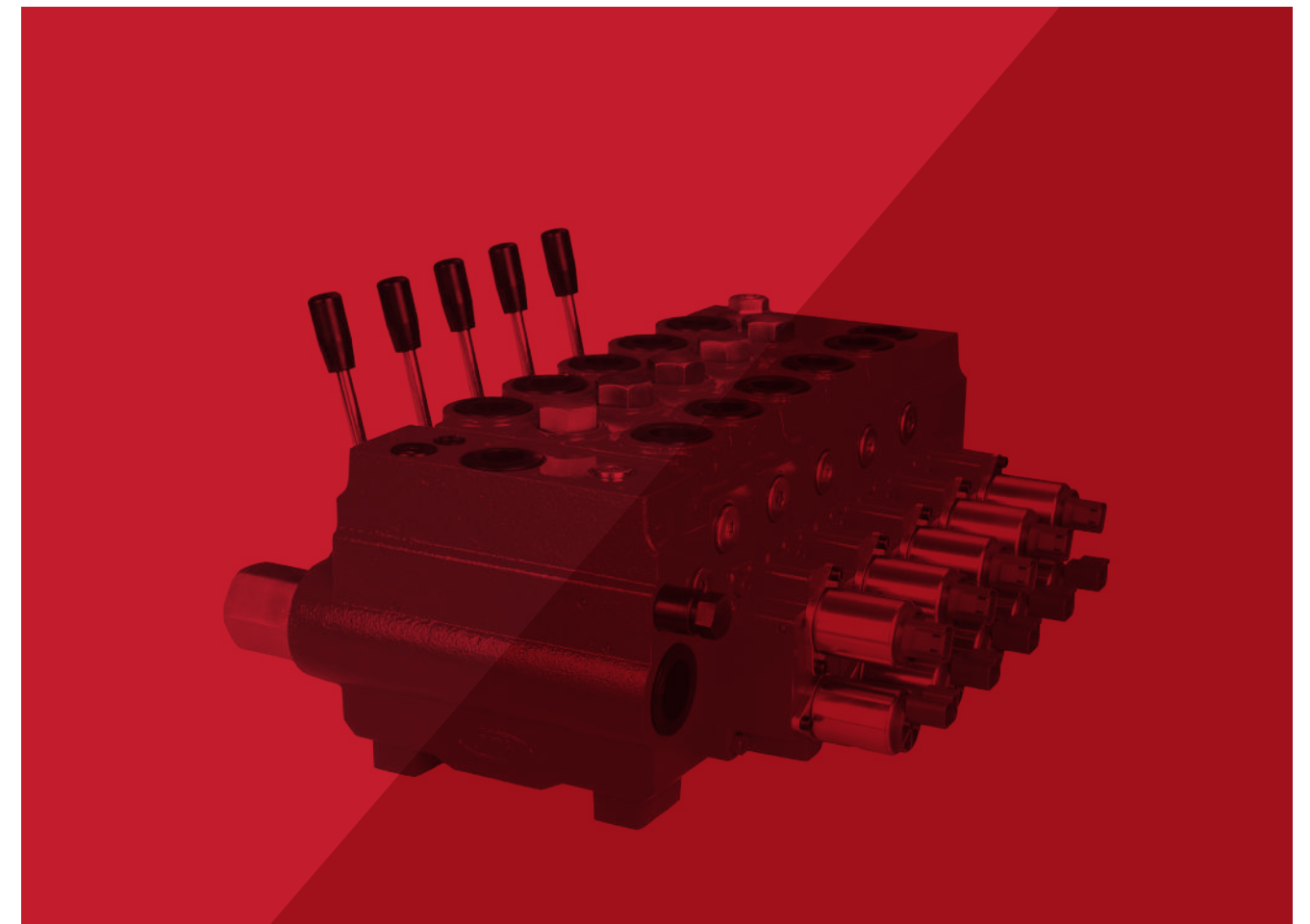

PROPORTIONAL VALVES

Load Sensitive and Pressure Compensation



SHANGHAI RYAN FLUID POWER CO.,LTD

Address: Rm 1703-2, 33#, 1228 Jiangchang Rd, Shanghai, China

Tel: +86-21-56626882

Email: sales@ryanhydraulic.com

Website: www.ryanhydraulic.com

Zip code: 200434



RYAN HYDRAULICS

Keep the concept seeking excellence, Ryan try our best to create more value for you with products and service.

Ryan Hydraulics

Supplier of the Whole Hydraulic System

Ryan Hydraulics manufacture was established in 1986, focusing on R&D, manufacture and sales of hydraulic products. Ryan Hydraulics owns world top level R&D team, as well as invention patents, sales covers global market. Targeting at vision of Excellence, Ryan Hydraulics keeps creating more value for customers by quality products, professional technology and experienced service.

645,835 sq.ft Modern Manufacture

Since the opening of 3rd generation modern manufacture in 2015, the total area covers 1,291,669 sq.ft, while the construction area covers 645,835 sq.ft, there are IT machining equipment, test and inspection equipment, meets various requirement of global customers.

Customer First

With leading technology, quality product, and professional service, Ryan Hydraulics has covered the global market with more than 60 countries and regions, become the strategic partner of many international famous OEM enterprises.

Instant Efficient Service

Technical Team offers accurate solutions to the service, including the product model selection, product test, installation and commissioning, debugging etc., so as to keep in touch with right department of each customer in time and respond to the customer's requirement.



9 Series Products

Covers the Whole Hydraulic Business

As a supplier of hydraulics, our business covers: hydraulic motors, hydraulic control valves, hydraulic gear pumps, power units and hydraulic systems, etc. Products are widely used in construction machinery, agricultural machinery, industry equipment.



Contents

Ryan Proportional Control Valves

	04–14	└ GBV100 Proportional Control Valves
GBV200 Proportional Control Valves	└	16–34

GBV100 Proportional Control Valves

Introduction	└	04
	05	└ Dimensions
Flow Characteristic for Standard Spool	└	05
	06	└ Inlet Section Valve Function and Schematics
Inlet Section Dimensions	└	07
	08	└ Main Valve Function and Schematics
End Cap Function and Schematics	└	09
	10	└ Drive Types for Main Valve Section
Main Spool Functions	└	11
	12	└ Hydraulic System Examples
Ordering Code	└	13–14

Introduction of GBV100

GBV100 Proportional valve is a load sensitive and post pressure compensated proportional stackable valve. For post pressure compensation valve, it can distribute flow proportionally for each working function. Because of the pressure compensation, working flow is independent with load. All the proportional valves in this series have been load sensitive, and spring centered. We can choose different plugin unit for the main valve body to accomplish different function. This series valve is building with modular design concept, system designer can choose different module to accomplish various complicate system design. Valve spool can provide excellent flow characteristics and low flow force.

Functions

- Inlet section matches with fixed displacement pump
- Inlet section matches with variable displacement pump
- Double control operations
- Over load protections
- Manual proportional valve can provide mechanical detent function
- Main valve with float function

Valve Options

- Manually controlled proportional valve or mechanically controlled flow sharing proportional valve
- Hydraulic pilot controlled proportional valve or hydraulic pilot controlled flow sharing proportional valve
- Electrically controlled on/off valve or electrically controlled flow sharing proportional valve
- Electro-hydraulic proportional valve or electro-hydraulic flow sharing proportional valve

Max flow of this series is 100L/min. Rated pressure is 31MPa.

Electro-Hydraulic proportional valve can use two direct current coils: 12V DC and 24V DC, relevant current is 0 ~ 1.5 Amp and 0 ~ 0.75 Amp.

Dimensions

Two Section Manually Operated Proportional Stack Valve

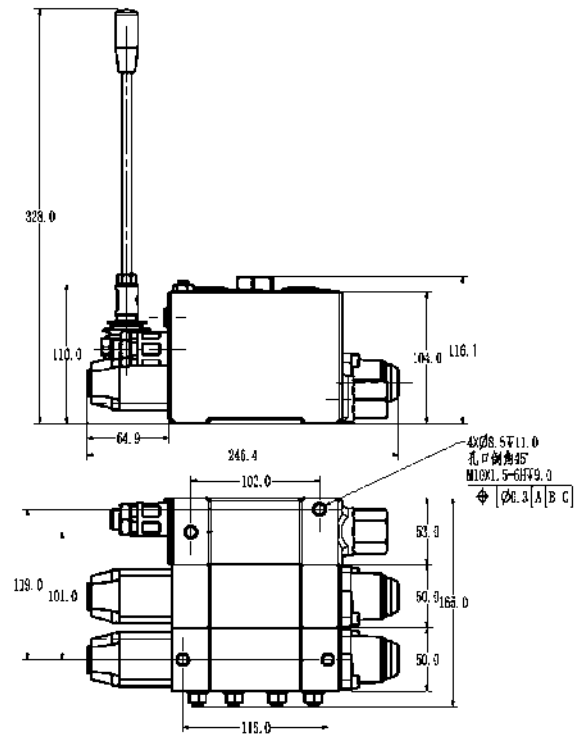

Two Section Electro-hydraulic Proportional Stack Valve

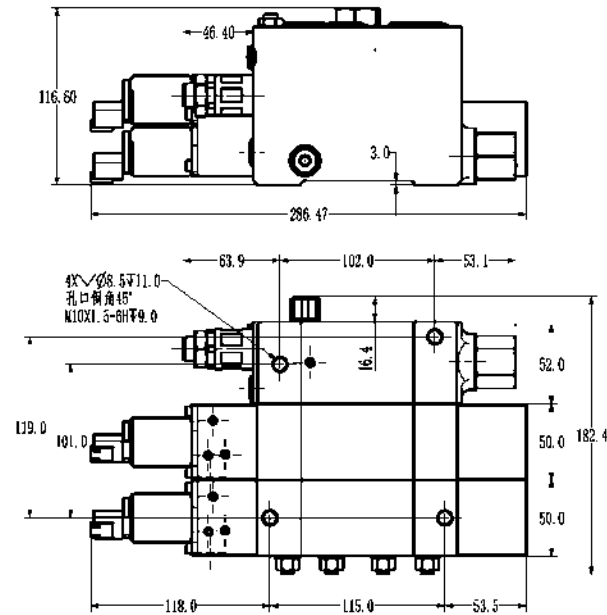

Characteristic for Standard Spool

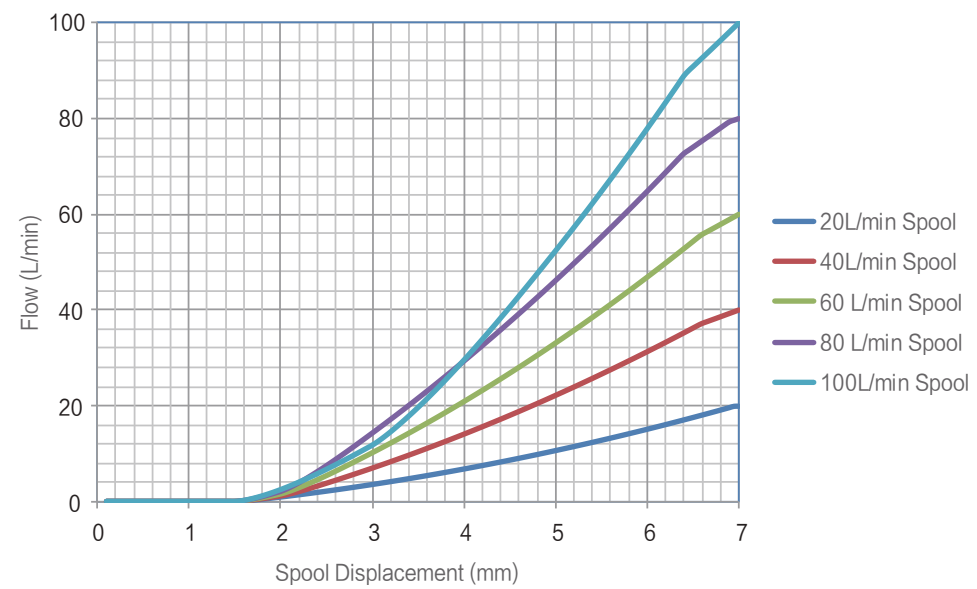

Inlet Section Valve Functions and Schematics

Code	Diagram	Function	Default Port Size
J01		Used in fixed displacement pump system with pilot oil source	LS: G1/4 TO: G1/4 T: M22X1.5 P: M22X1.5
J02		Used in fixed displacement pump system without pilot oil source	LS: G1/4 TO: G1/4 T: M22X1.5 P: M22X1.5
J03		Used in variable displacement pump system with pilot oil source	LS: G1/4 TO: G1/4 T: M22X1.5 P: M22X1.5
J04		Used in variable displacement pump system without pilot oil source	LS: G1/4 TO: G1/4 T: M22X1.5 P: M22X1.5

Inlet Section Dimensions

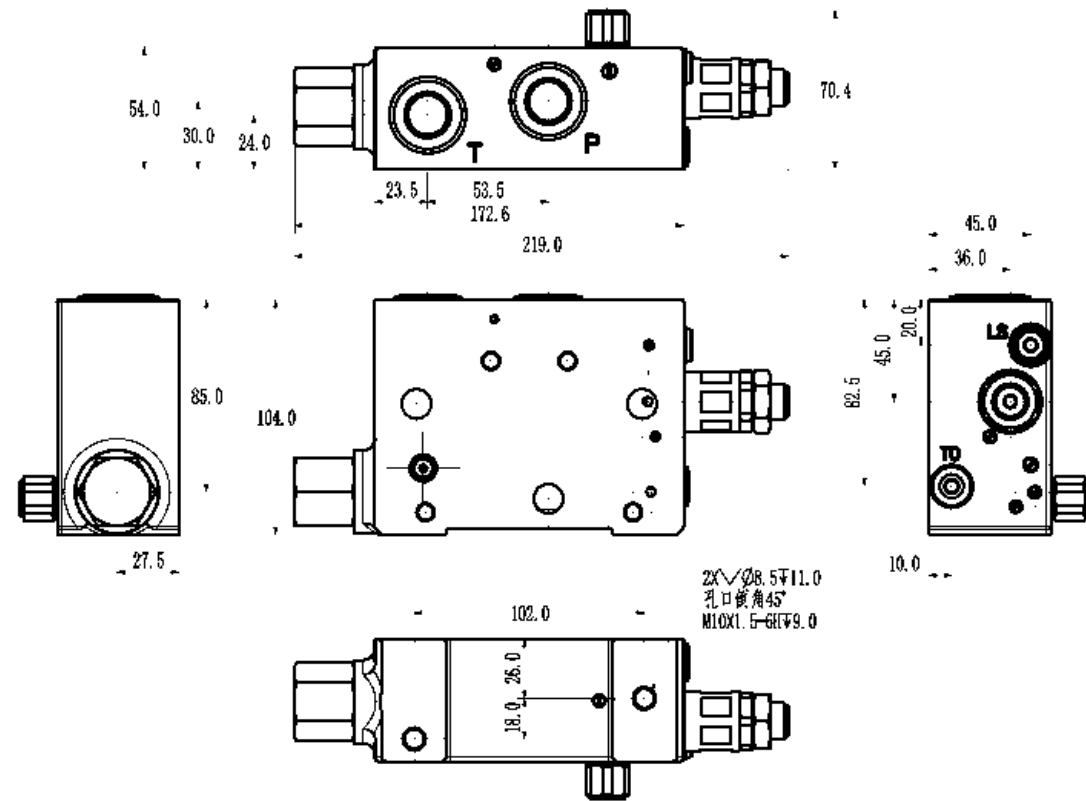

Main Valve Functions and Schematics

Code	Diagram	Function	Notes
Z01		Post pressure compensation (Proportional flow sharing) Basic valve body	Standard Port Size A Port: M22 × 1.5 B Port: M22 × 1.5
Z02		Post pressure compensation (proportional flow sharing) Check valve in working port to prevent air suction of system	Usually used in hydraulic motor
Z03		Post pressure compensation (proportional flow sharing) Relief valve in working port to prevent overload and check valve to prevent air suction of system	



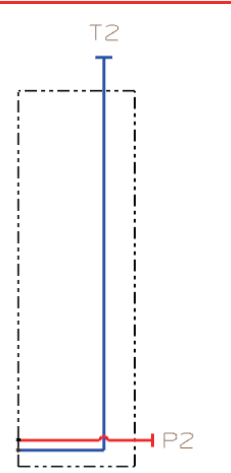

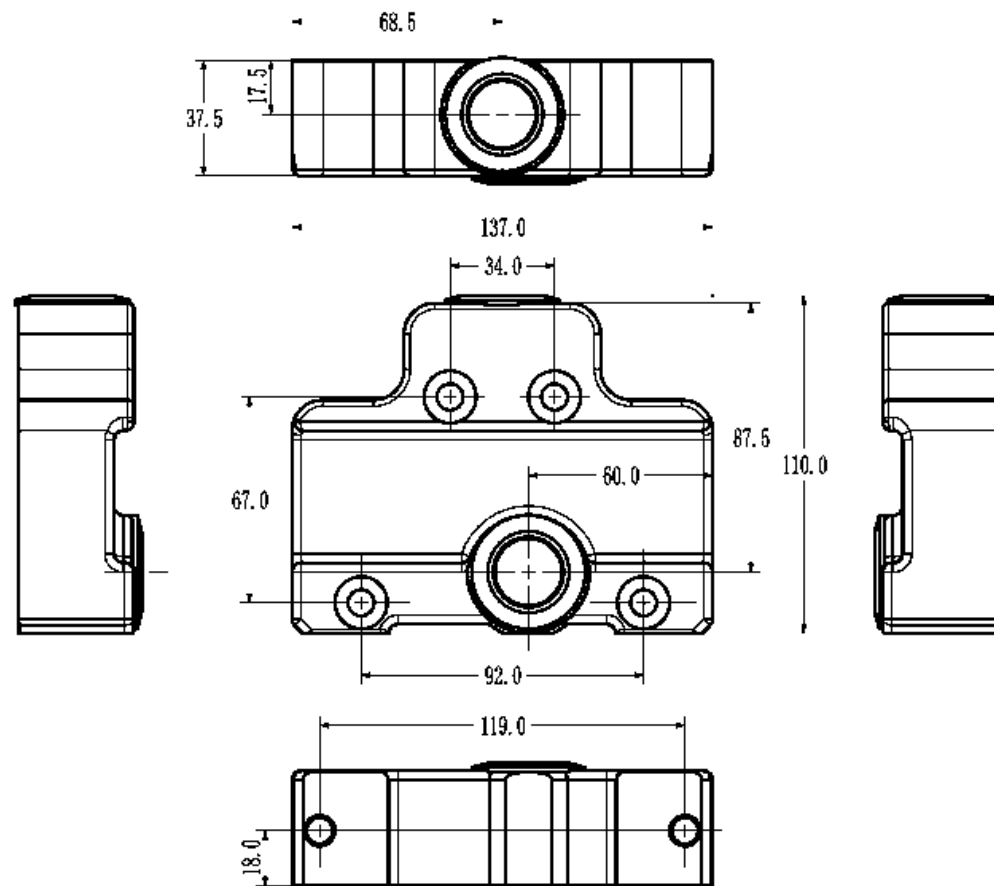

End Cap Functions and Schematics

Code	Diagram	Function	Notes
D01		Usually used in fixed displacement pump	Port Size (If do not need end cap, Please use code D00) T2: M22 × 1.5 P2: M22 × 1.5

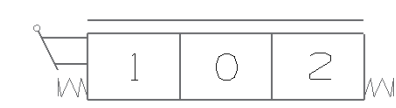
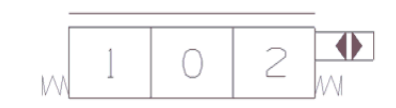
Dimensions of Rear Cover

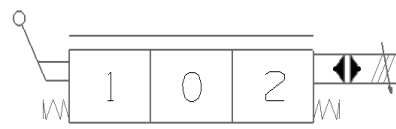

Drive Types for Main Valve Section

Spool Code	Symbol	Function
Q1		Standard manual proportion
Q2		Hydraulic control proportion
Q3		Manual proportion with friction location
Q4		Manual proportion with float
Q5		Electric (Switch)
Q6		Standard electro-hydraulic proportion
Q7		Standard electro-hydraulic proportion Manual
Q8		Electro-hydraulic proportion with float

Main Spool Functions

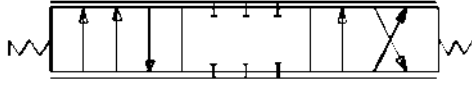
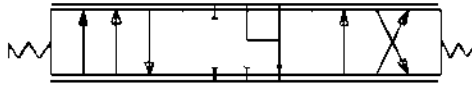
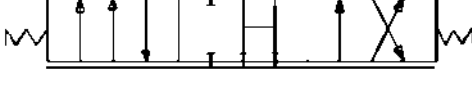
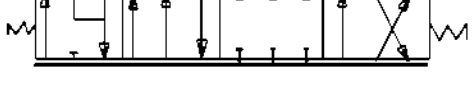
Spool Code	Spool Type	Function	Notes
FG1		Standard three position four way O function Post pressure compensation	Usually used in controlling hydro cylinder
FG2		Three position four way Y function Post pressure compensation	Usually used in controlling motor
FG3		Three position four way H function Post pressure compensation	Usually used in controlling hydro cylinder
FG4		Standard three position four way with float function Post pressure compensation	Usually used in controlling hydro cylinder

** All spools are spring centered.

Hydraulic System Examples

Electro-hydraulic Proportional Control System for Variable Pump (Post Pressure Compensation)

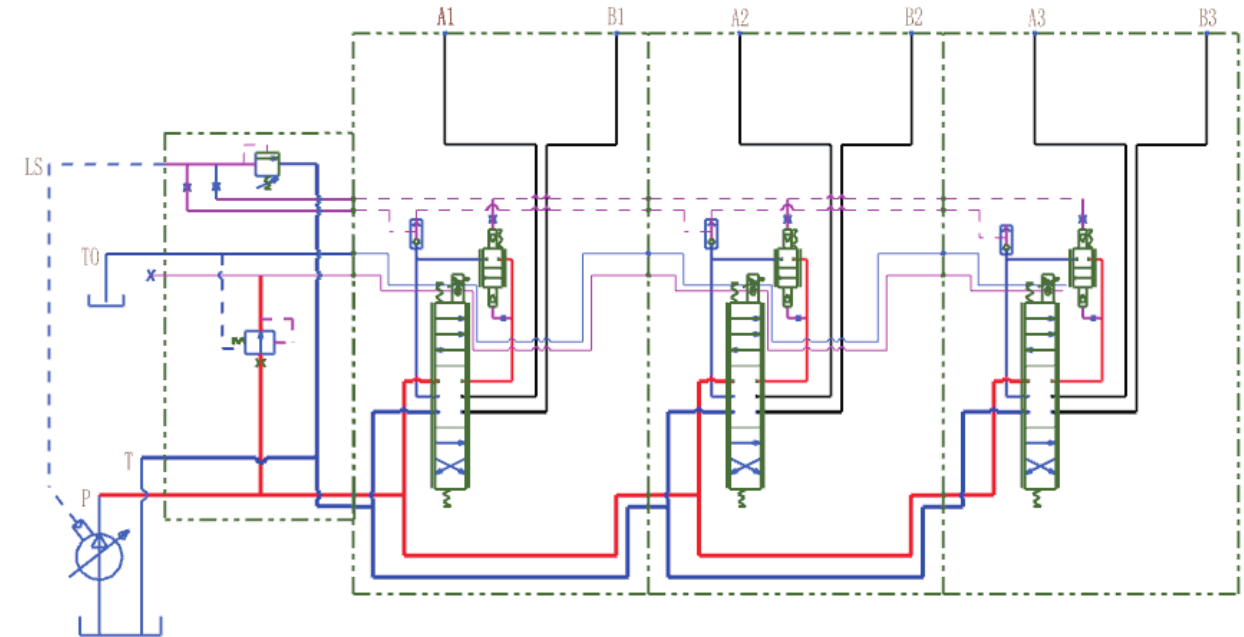

Electro-hydraulic Proportional Control System with Fixed Displacement Pump (Post Pressure Compensation)

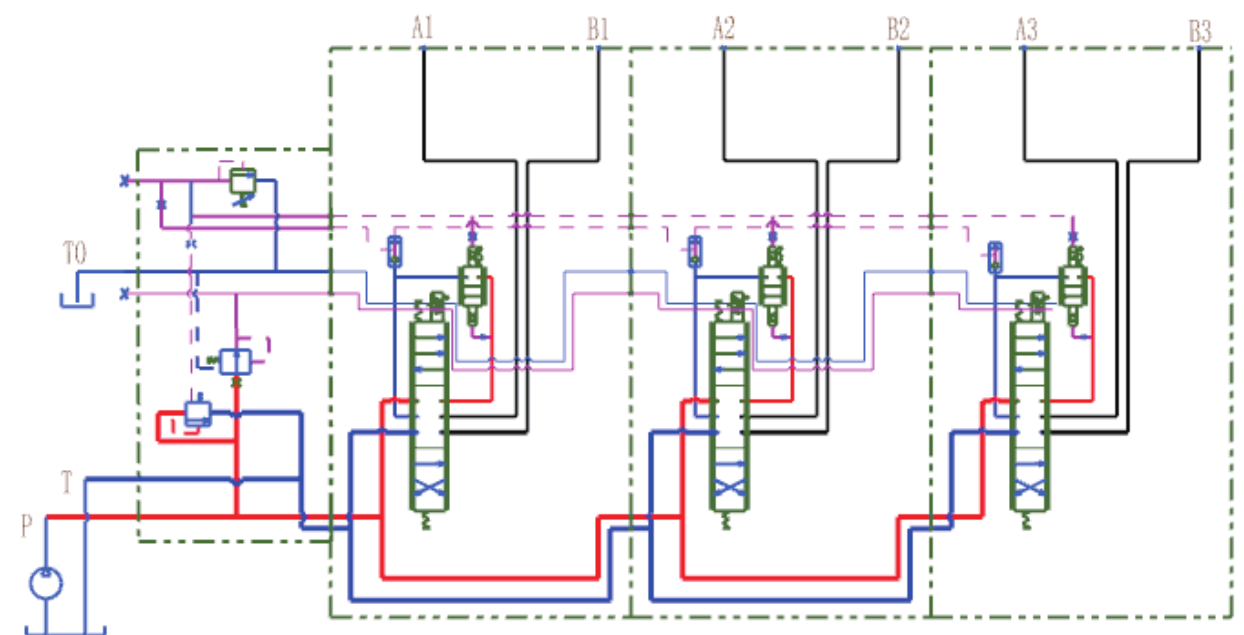

Ordering Code

GBV100	/*	-J**	/***	-D**	-O1	-Z**	Q*	-FG*	-DC/**	-QL/**	-O2	...
a	b	c	d	e	f	g	h	i	j	k	l	m

- | | |
|--|--------------------------------|
| Ⓐ Model | Ⓜ Drive Style Code |
| Ⓑ Number of Main Section | Ⓨ Spool Function Code |
| Ⓒ Inlet Section Code | Ⓩ Electrical option |
| Ⓓ LS Relief Setting (bar) | 12VDC、24VDC、00=none electrical |
| Ⓔ Endcap Code (End Section) If no need for endcap use Code D00 | Ⓚ Expected Flow Rate |
| Ⓕ First Main Section | Ⓛ Second Section |
| Ⓖ Main Section Code | Ⓜ |

**Port Size: If user do not want our standard size, you have to not only provide ordering code, but also you have to specify all the port sizes.

-O2	-Z01	-Q6	-FG1	-DC/24	-QL/80	-O3	-Z01	-Q6	-FG1	-DC/24	-QL/30
l	m	n	o	p	q	r	s	t	u	v	w

- | | |
|-------------------------|-------------------------|
| Ⓛ Second Section | Ⓡ Third Section |
| Ⓜ Main Section Code | Ⓢ Main Section Code |
| Ⓨ Drive Style Code | Ⓣ Drive Style Code |
| Ⓩ Spool Function Code | Ⓤ Spool Function code |
| Ⓛ 24VDC | Ⓥ 24VDC |
| Ⓚ Expected Flow 80L/min | Ⓦ Expected Flow 30L/min |

Order example notes: From system example 1) we know that the system has three sections. Inlet relief valve setting pressure is 210bar. There is no end section. The first section has no load relief valve. The section is droved by 24V DC coils. The spool function is a O type. The desired flow for the 100L/min. The second section is also droved by 24VDC coils. There is no overload relief on either A or B port. The spool function is O type, The de-sired flow is 80L/min. The third section is droved by 24V DC coils. No overload relief on either A or B port. Spool function is O type, Desires 30L/min flow.

Ordering Example

GBV100	/3	-J03	/210	-D00	-O1	-Z02	-Q6	-FG1	-DC/24	-QL/100
a	b	c	d	e	f	g	h	i	j	k

- | | |
|----------------------------|--------------------------|
| Ⓐ Model | Ⓜ Drive Style |
| Ⓑ Three Main Sections | Ⓨ Spool Function |
| Ⓒ Inlet Code | Ⓩ 24VDC |
| Ⓓ LS Relief Setting 210bar | Ⓚ Expected Flow 100L/min |
| Ⓔ No Endcap | |
| Ⓕ First Section | |
| Ⓖ Main Section Code | |

Contents

GBV200 Proportional Control Valves

Introduction	16	
	17	└─ Dimensions
Flow Characteristic for Standard Spool	18	
	18	└─ Flow Characteristic for the Spools Using Linear Notches
Inlet Section Valve Function and Schematics	19	
	21	└─ Inlet Section Dimensions
Main Valve Function and Schematics	23	
	27	└─ End Cap Function and Schematics
End Cap Dimensions	28	
	29	└─ Drive Types for Main Valve Section
Main Spool Functions	30	
	31	└─ Hydraulic System Examples
Ordering Code	33	
	33	└─ Ordering Example

Introduction of GBV200

GBV200 Proportional valve is a load sensitive and post pressure compensated proportional stackable valve. For post pressure compensation valve, it can distribute flow proportionally for each working function. Because of the pressure compensation, working flow is independent with load. All the proportional valves in this series have been load sensitive, and spring centered. We can choose different plugin unit for the main valve body to accomplish different function. This series valve is building with modular design concept, system designer can choose different module to accomplish various complicate system design. Valve spool can provide excellent flow characteristics and low flow force.

Functions

- Inlet section matches with fixed displacement pump
- Inlet section matches with variable displacement pump
- Double control operations
- Over load protections
- Manual proportional valve can provide mechanical detent function
- Main valve with float function

Valve Options

- Manually controlled proportional valve or mechanically controlled flow sharing proportional valve
- Hydraulic pilot controlled proportional valve or hydraulic pilot controlled flow sharing proportional valve
- Electrically controlled on/off valve or electrically controlled flow sharing proportional valve
- Electro-hydraulic proportional valve or electro-hydraulic flow sharing proportional valve

Max flow of this series is 220L/min. Rated pressure is 31MPa.

Electro-Hydraulic proportional valve can use two direct current coils: 12V DC and 24V DC, relevant current is 0 ~ 1.5 Amp and 0 ~ 0.75 Amp.

Dimensions

GBV200 Series Universal Proportional Valve Dimensions

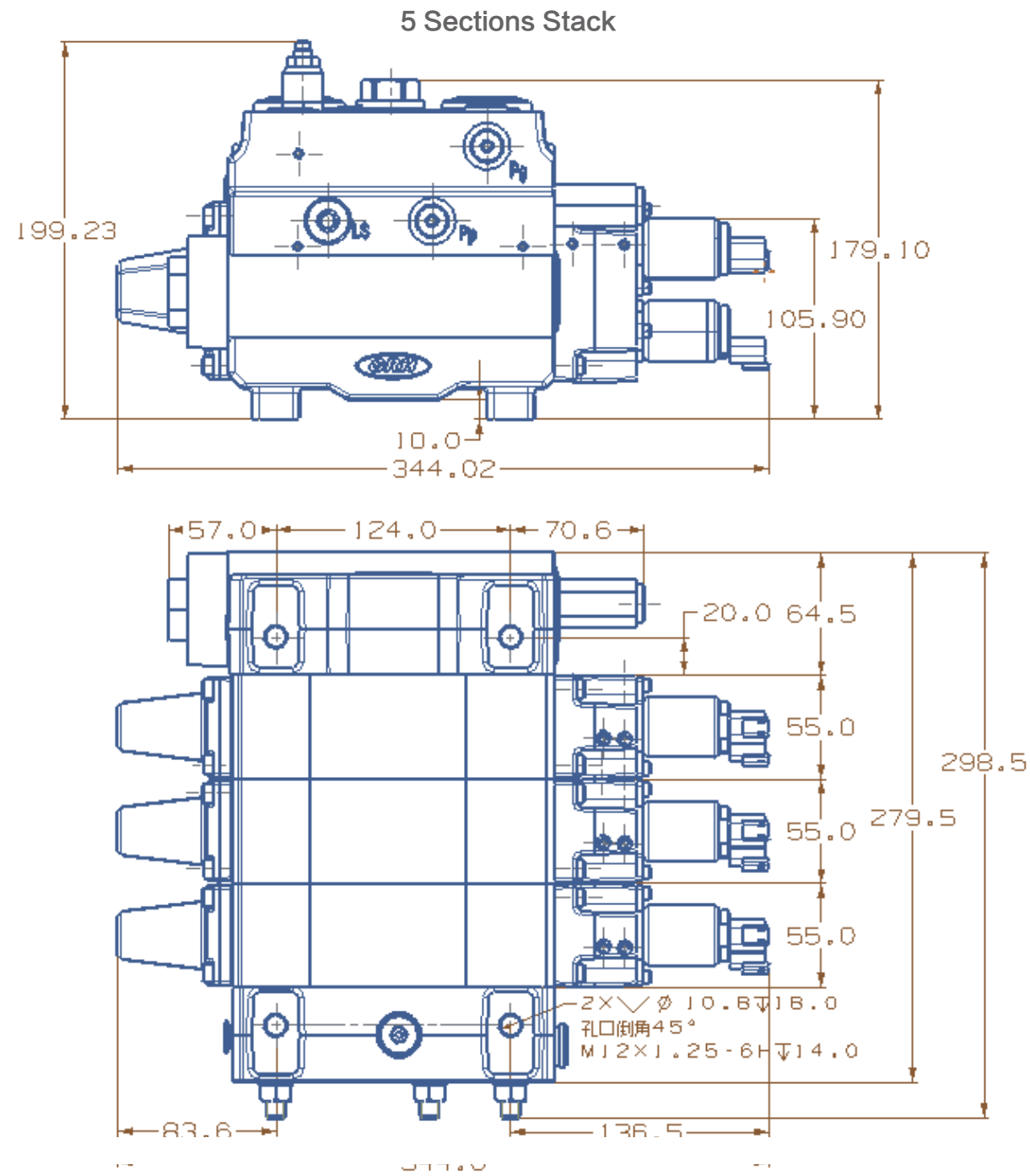

Flow Characteristic for Standard Spool

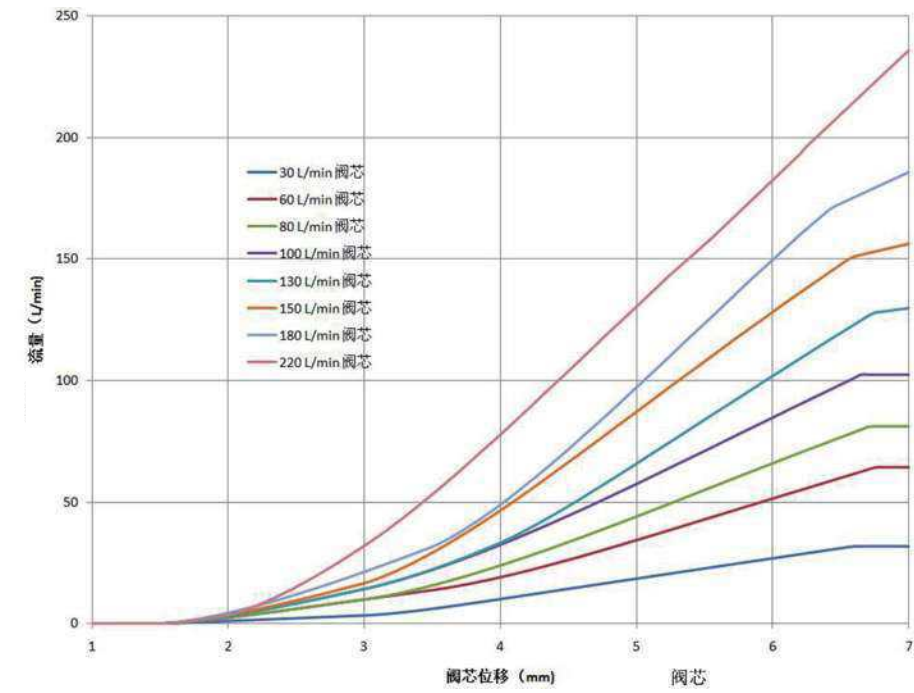

Flow Characteristic for Standard Spool

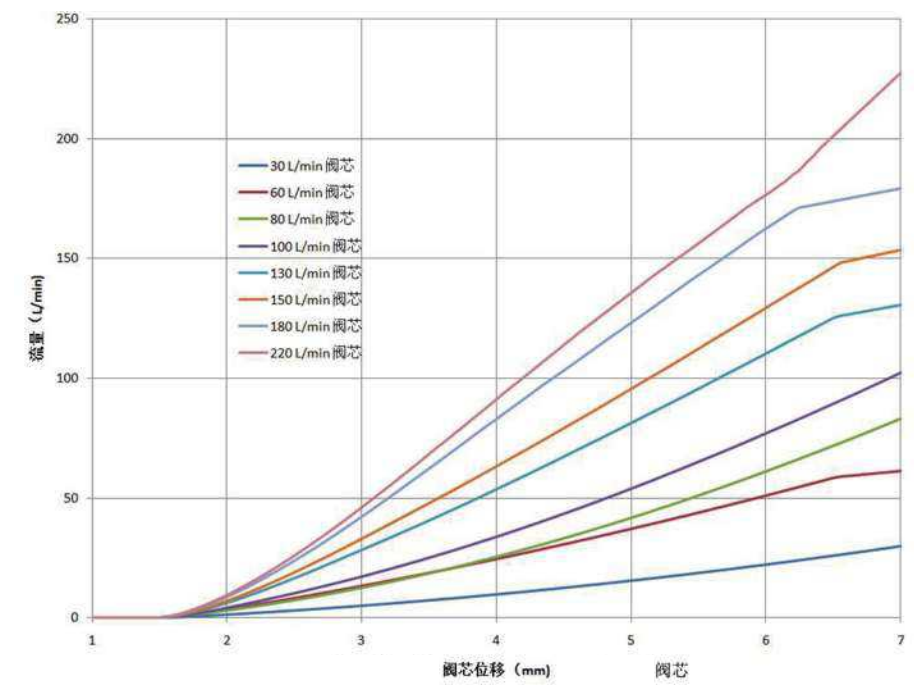

Inlet Section Valve Function and Schematics

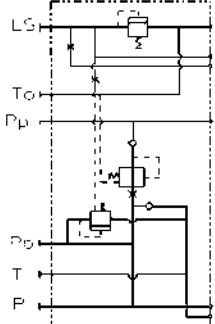
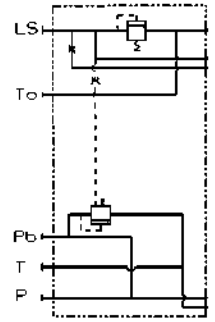
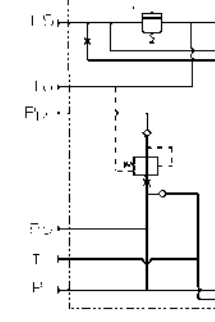
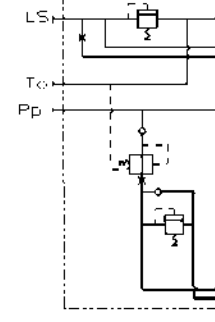
Code	Schematics	Main Function	Notes
J01		Used in closed loop fixed displacement pump system, with pilot supply	LS:M12 × 1.5 TO:M12 × 1.5 T:M27 × 2 Pp:M12 × 1.5 Pb:M12 × 1.5 P:M27 × 2
J02		Used in closed loop fixed displacement pump system, without pilot supply	LS:M12 × 1.5 TO:M12 × 1.5 T:M27 × 2 Pb:M12 × 1.5 P:M27 × 2
J03		Used in closed loop variable displacement pump system, with pilot supply	LS:M12 × 1.5 TO:M12 × 1.5 T:M27 × 2 Pp:M12 × 1.5 Pb:M12 × 1.5 P:M27 × 2
J04		Used in closed loop fixed displacement pump system, without pilot supply	LS:M12 × 1.5 TO:M12 × 1.5 T:M27 × 2 Pb:M12 × 1.5 P:M27 × 2

Inlet Section Valve Function and Schematics

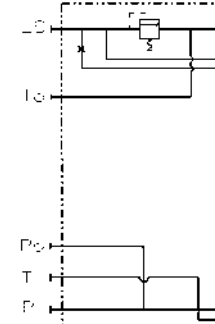
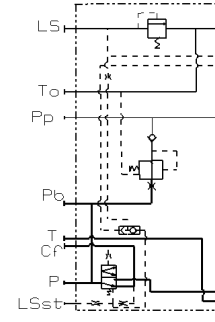
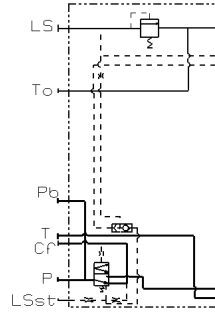
Code	Schematics	Main Function	Notes
J05		Used in closed loop variable displacement pump system, low flow system with pilot supply	LS:M12 × 1.5 TO:M12 × 1.5 Pp:M12 × 1.5
J06		Used in closed loop variable displacement pump system, with priority valve and pilot supply	LS:M12 × 1.5 TO:M12 × 1.5 T:M27 × 2 Pp:M12 × 1.5 Pb:M12 × 1.5 P:M27 × 2
J07		Used in closed loop variable displacement pump system, with priority valve without pilot supply	LS:M12 × 1.5 TO:M12 × 1.5 T:M27 × 2 Pb:M12 × 1.5 P:M27 × 2

Inlet Section Dimensions

Common Inlet Section

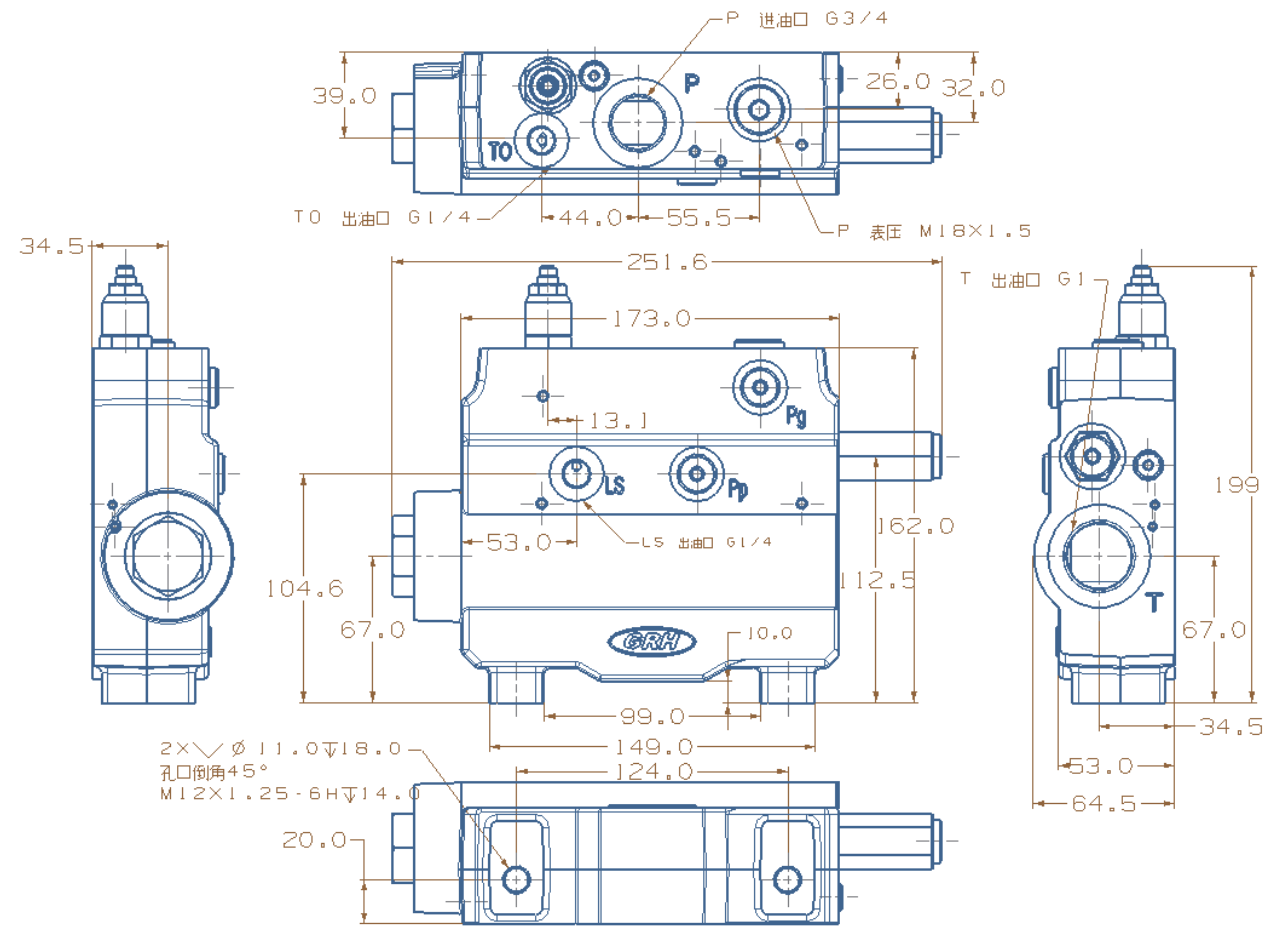

Inlet Section Dimensions

Dimensions of the Inlet Section With Priority Valve

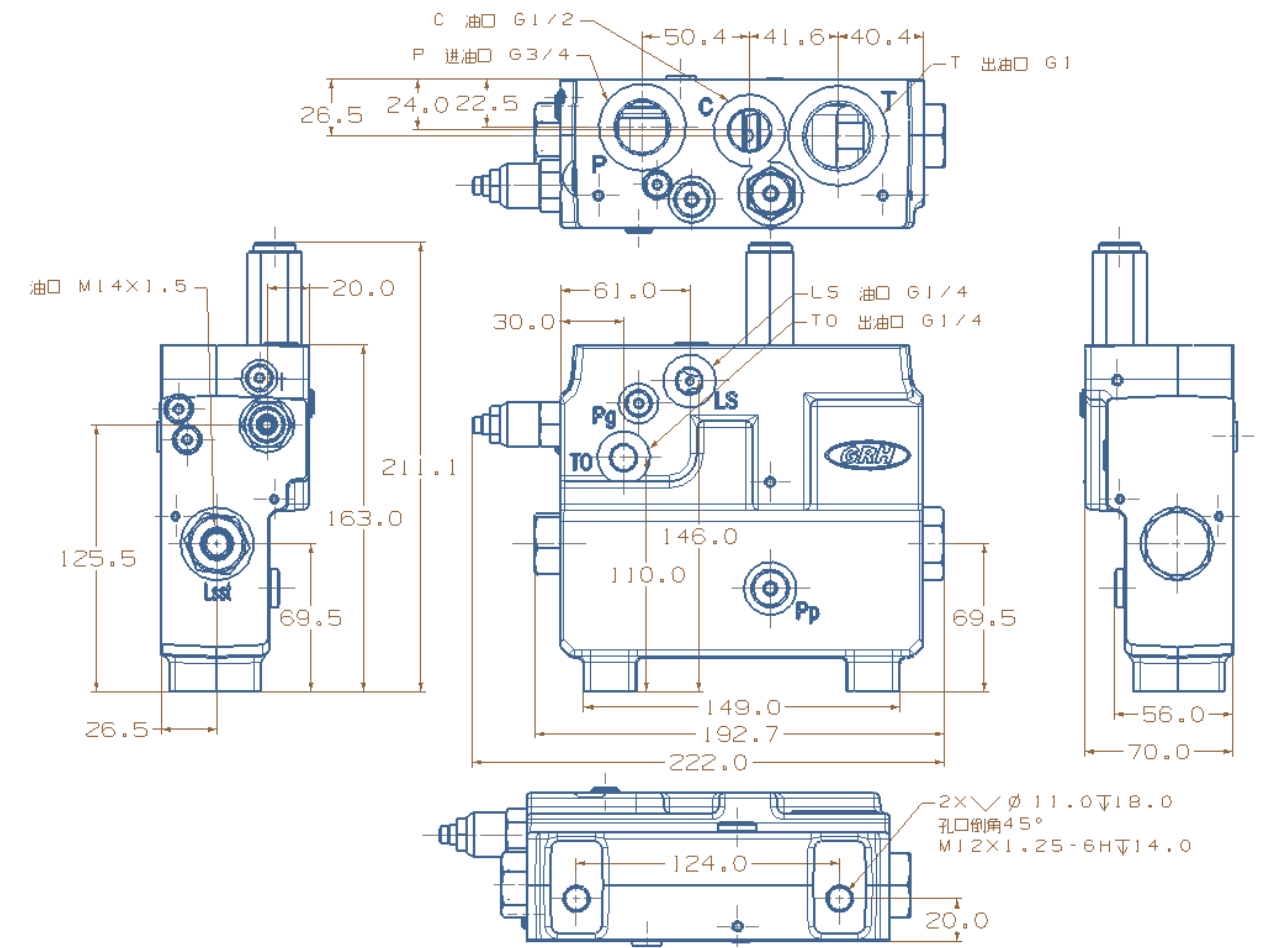

Main Valve Function and Schematics

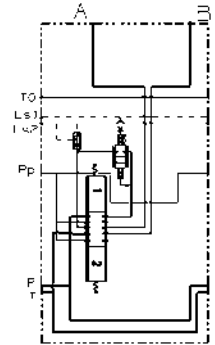
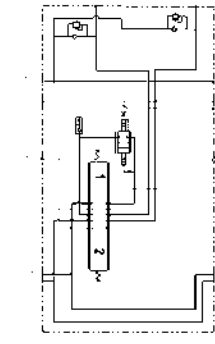
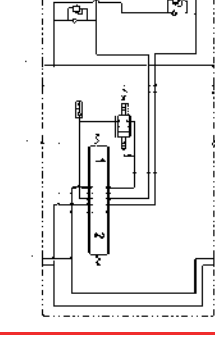
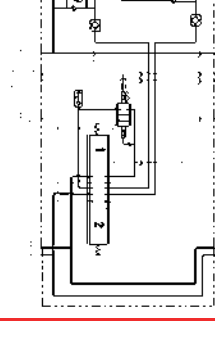
Code	Schematics	Main Function	Notes
Z01		Post pressure compensation (proportional flow sharing) Basic valve section	
Z02		Post pressure compensation (proportional flow sharing) Anti cavitation valve on work ports to prevent cavitations	Commonly used in hydraulic motor applications
Z03		Post pressure compensation (proportional flow sharing) Provides work ports overload protections and anti cavitation valve to prevent cavitations	
Z04		Post pressure compensation (proportional flow sharing) Provides work ports overload protections Provides P.O. checks to hold loads and anti cavitation valve to prevent cavitations	Most commonly used in cylinder load and holding The P.O. check is used to control load lowering It is also used for swing cylinder and motor

Main Valve Function and Schematics

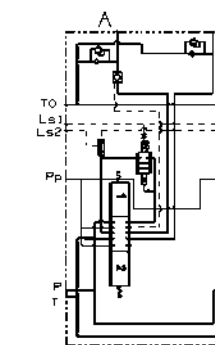
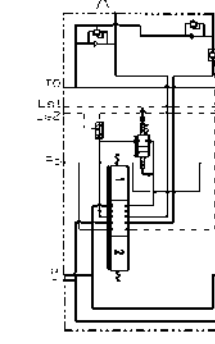
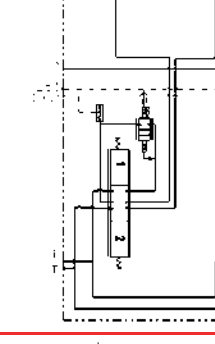
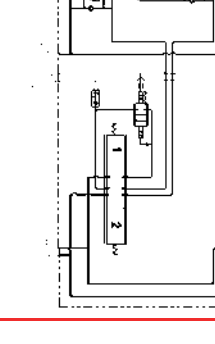
Code	Schematics	Main Function	Notes
Z05		Post pressure compensation (proportional flow sharing) Provides work ports overload protections Anti cavitation valve to prevent cavitations	Most commonly used in cylinder load holding applications The P.O. check is used to control load lowering
Z06		Post pressure compensation (proportional flow sharing) Provides work ports overload protections Anti cavitation valve to prevent cavitations Provides P.O. check to hold load on "B" port	Most commonly used in cylinder load holding applications The P.O. check is used to control load lowering
Z07		Post pressure compensation (proportional flow sharing) Basic valve section Manually operated	Commonly used in manually controlled proportional valves
Z08		Post pressure compensation (proportional flow sharing) Provides work ports overload protections and anti cavitation valve to prevent cavitations Manually operated	

Main Valve Function and Schematics

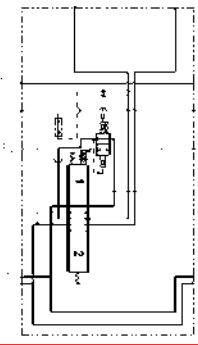
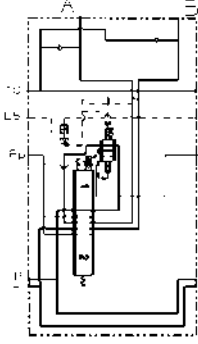
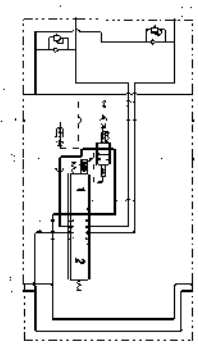
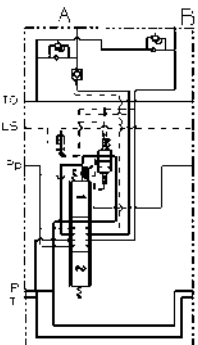
Code	Schematics	Main Function	Notes
Z09		Pre-pressure compensation (proportional flow) Basic valve section	
Z10		Pre-pressure compensation (proportional flow) Anti cavitation valve on work ports to prevent cavitations	
Z11		Pre-pressure compensation (proportional flow) Provides work ports overload protections and anti cavitation valve to prevent cavitations	
Z12		Pre-pressure compensation (proportional flow) Provides work ports overload protections and anti cavitation valve to prevent cavitations Provides P.O. check to hold load on "A" port	Most commonly used in cylinder load holding applications The P.O. check is used to control load lowering

Main Valve Function and Schematics

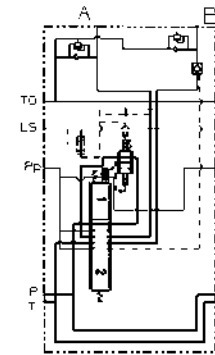
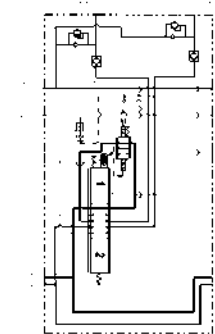
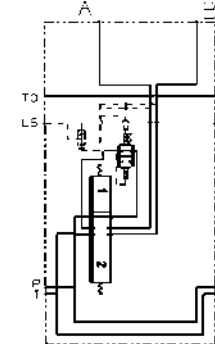
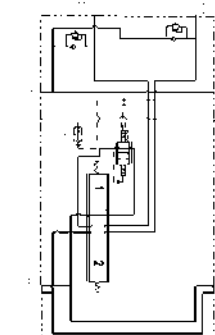
Code	Schematics	Main Function	Notes
Z13		Pre-pressure compensation (proportional flow) Provides work ports overload protections and anti cavitation valve to prevent cavitations Provides P.O. check to hold load on "B" port	Commonly used in cylinder load holding applications The P.O. check is used to control load lowering
Z14		Pre-pressure compensation (proportional flow) Provides work ports overload protections and anti cavitation valve to prevent cavitations Provides P.O. checks to hold loads	Most commonly used in cylinder load holding applications. It is also used for swing cylinder and motor applications
Z15		Pre-pressure compensation (proportional flow) Basic valve section Manually operated	Commonly used manually controlled proportional valve.
Z16		Pre-pressure compensation (proportional flow) Provides work ports overload protections and anti cavitation valve to prevent cavitations Manually operated	Commonly used manually controlled proportional valve with system protections

End Cap Function and Schematics

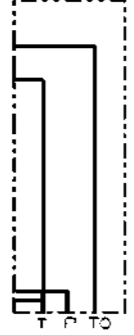
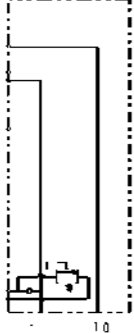
Code	Schematics	Main Function	Notes
D01		Usually used in closed loop of variable displacement pump system	TO:M12 × 1.5 T:M27 × 2 P:M27 × 2
D02		Usually used in fixed displacement pump system	TO:M12 × 1.5 T:M27 × 2 P:M27 × 2

End Cap Dimensions

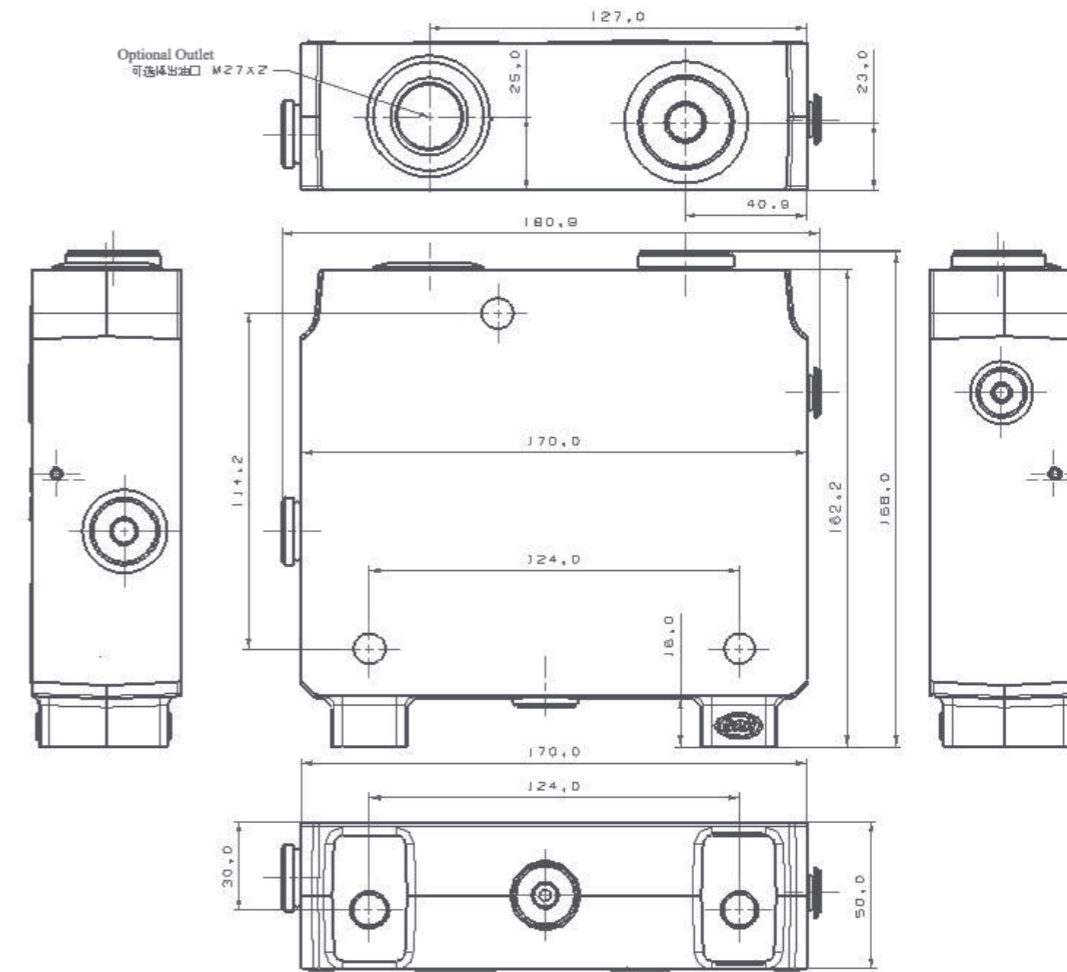

Drive Types for Main Valve Section

Spool code	Symbol	Function
Q1		Standard Manually Operated
Q2		Hydraulic Control
Q3		Manually operated with detent
Q4		Manually operated with floating function
Q5		Electric on/off control
Q6		Standard Electro-hydraulic proportional control
Q7		Standard Electro-hydraulic proportional control with manual override
Q8		Standard Electro-hydraulic proportional control with floating function

Main Spool Function

Spool code	Symbol	Function	Notes
FG1		Standard three position four way function Post pressure compensation	Commonly used in hydraulic cylinder applications
FG2		Three position three way Function Post pressure compensation	Commonly used in hydraulic motor applications
FG3		Standard three position four way function, with fourth position floating Post pressure compensation	Commonly used in hydraulic cylinder applications
FG4		Standard three position four way function Pre-pressure compensation	Commonly used in hydraulic cylinder applications
FG5		Three position three way function Pre-pressure compensation	Commonly used in hydraulic motor applications
FG6		Standard three position four way function, with fourth position floating Pre-pressure compensation	Commonly used in hydraulic cylinder applications

Hydraulic System Examples

Electro-hydraulic proportional control circuit with variable displacement pump (Post pressure compensation)

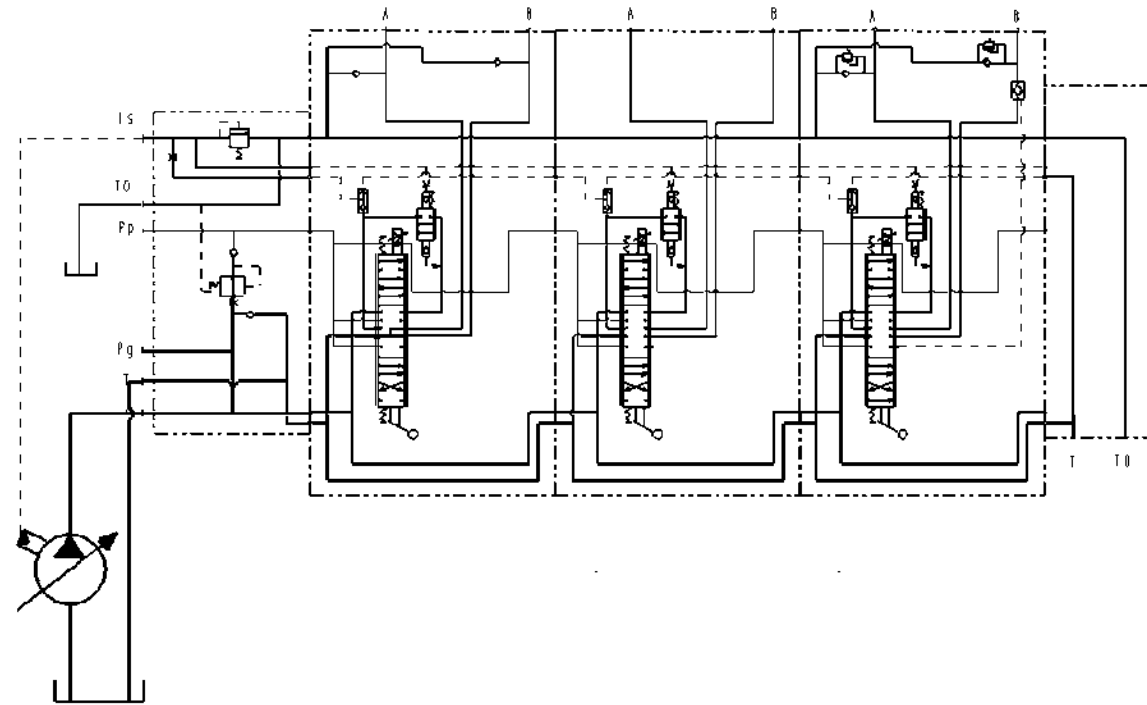

Hydraulic System Examples

Electro-hydraulic proportional control circuit with variable displacement pump (Pre-pressure compensation)

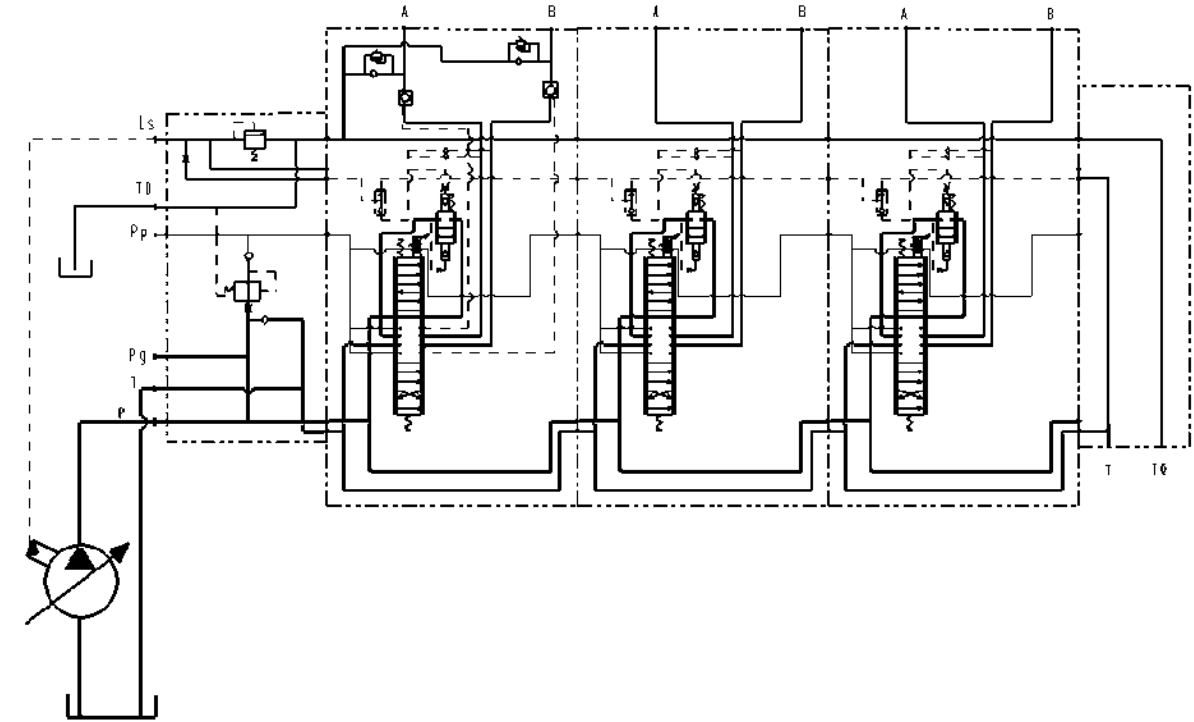

Electro-hydraulic proportional control circuit with fixed displacement pump (Post pressure compensation)

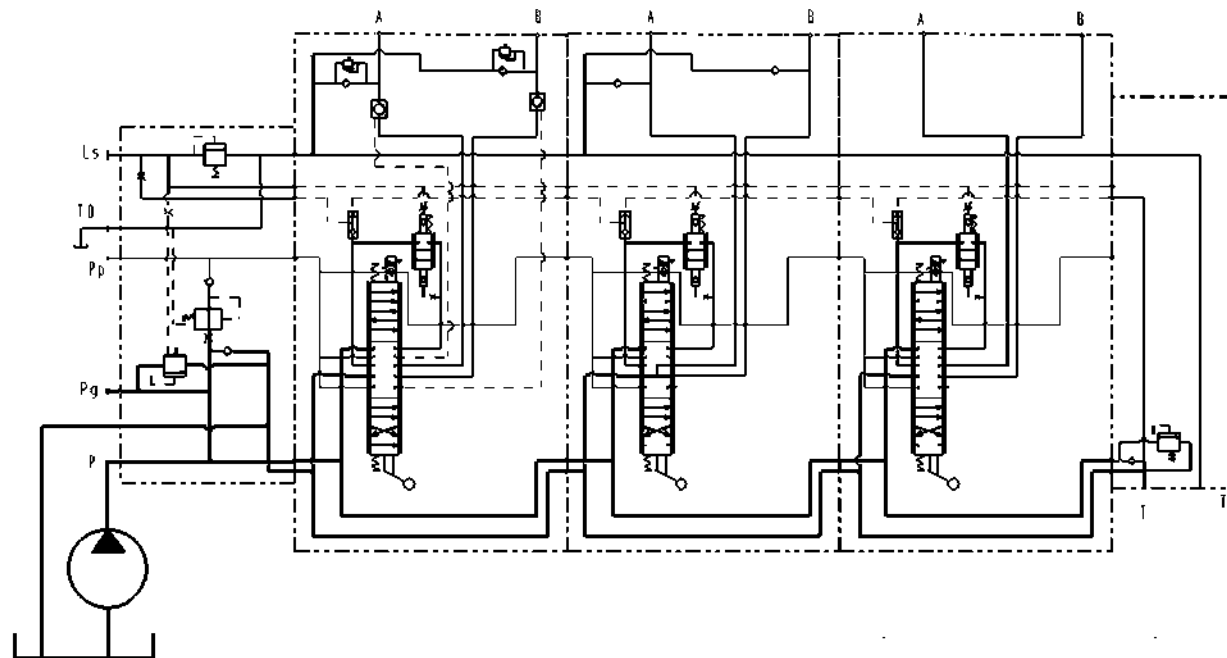

Electro-hydraulic proportional control circuit with fixed displacement pump (Pre-pressure compensation)

