

# Intensium<sup>®</sup> Max+ 20E

## Very high energy lithium-ion container 1.2 MWh – 2.5 MW

Intensium<sup>®</sup> Max is Saft's ready to install containerized Energy Storage System (ESS) designed for grid applications requiring high energy capacity, outstanding efficiency and long life.

Built with latest generation of NMC/NCA Li-ion technology, Intensium<sup>®</sup> Max+ 20E is a very compact and fully integrated storage system, combining high energy density with high operational reliability. Conceived for loads of 1h and above, its 2.5 MW peak capability yet enables dynamic operation at variable depths of discharge, with energy throughputs equalling several full cycles per day.

Its modular design based on up to 18 parallel strings of 30 Synerion 24E modules allows a power rating of 2.5 MW in discharge and 0.9 MW in charge.

### Applications

- Integration of variable renewables: smoothing, shaping and shifting
- Peak load management: substation peak shaving, management of feeder congestion, load levelling

### Features

- Latest generation NMC/NCA Li-ion technology
- Advanced industrial design offering highest safety and robustness
- 20 years design life
- Proven architecture for high availability
  - Modularity with one Battery Management Module (BMM) per string
  - Master Battery Management Module (MBMM) for global management
  - One PLC for external communication and remote monitoring
- Sophisticated battery management for enhanced operability in grid applications
  - Monitoring and control of voltage and temperature at cell level
  - Real time supervision of charge and discharge current limits
  - Real time indication of State of Charge (SOC)
  - Balancing of State of Charge (SOC) between cells and strings
  - Alarms and faults management (contactor opening rules)
  - Indication of State of Health (SOH) integrating cycling and calendar aging
  - Black box registering alarms and number of cycles
- Advanced thermal management system based on air conditioning unit and controllable fans



#### Nominal characteristics at + 25°C/+ 77°F

Voltage (V)	771
Capacity (C/5) (Ah)	1530
Rated energy (C/5) (kWh)	1180
Continuous discharge power (kW)	2500
Continuous charge power (kW)	850

#### Mechanical characteristics

Length (mm)	6058
Width (mm)	2438
Height w/o HVAC (mm)	2896
Height incl HVAC (mm)	3820
Weight (tonnes)	19.5

#### Electrical characteristics at + 25°C/+ 77°F

Minimum Voltage (V)	630
Maximum Voltage (V)	867
Maximum continuous discharge current (A)	3240
Maximum continuous recharge current (A)	1083
Discharge time at nominal power (h)	0.5
Time to full recharge (h)	1.5
Insulation resistance (1kVdc - 0C)	> 10mΩ
Dielectric	2.5kVdc

#### Operating conditions

Operating temperature	- 20°C/+ 55°C
Cycle efficiency (roundtrip, 1C)	96%
Self-discharge	<5% / month
Calendar life at 25°C / +77°F	> 25 years
Cycle life at 25°C / +77°F, 0.5C/0.5C, 80% DOD (*)	4200

(\*) 20% capacity loss



**SAFT**

- High cooling efficiency
- Temperature homogeneity
- Safety management system with smoke detection, fire suppression system and alarms

## Benefits

- Flexibility to provide both power and energy functions
- Low Total Cost of Ownership in complex applications
  - optimum power to energy ratio enabling application stacking
  - high energy throughput with minimum auxiliary consumption
  - long cycle life and calendar life despite increased temperatures
- Quick and cost effective installation, with containers delivered « plug and play » ex factories due to ready to deploy solution fully assembled ex factory, plug and play
- Easy system integration: compatible with most power conversion systems in the market
- Excellent flexibility: scalable configuration of strings and containers
- High availability and serviceability due to parallel connection of strings
- Low maintenance - diagnostic interface available
- Remote supervision capability

## Safety

- Safety driven design guarantees safe behavior in case of abuse usage or cell thermal runaway.
  - cell level: mechanical venting to release gases, materials selected for high temperature resistance
  - module level: electronic board for cell monitoring and balancing; structural protection to avoid thermal runaway propagation
  - string level: BMM to manage short-circuits, over-currents, overtemperature and over-voltages
  - container level: emergency push buttons, DC disconnect switch to perform maintenance, ground fault detection and fire suppression system
- Fire suppression system performs the following action in case of smoke detection:
  - Release of inert gases (nitrogen or argon) to stop combustion
  - Contactor opening
  - Information on external displays and with audible alarms
  - Stop of air conditioning unit and fans
  - Sending alarm to control system

Storage conditions	
Storage temperature	- 20°C/+ 55°C (- 4°F to + 131°F)
Storage time	6 months
Maximum altitude	3000 m above sea level
Maximum relative humidity	100% (controlled inside at 60%)
Compliance to standards	
Cell safety	UL 1642, IEC 62619
Module safety	EN 50178 / IEC 60950
Container safety	IEC 61508 (SIL1)
EMC	IEC 62 040-2 Cat C1 and C3
Container protection class (operation)	IP 33
Container dimension and transport	ISO668
Container corrosion protection	ISO 12944 Level C5I
Seismic	Eurocode zone 5 / IEEE 693 high level
Environment	IEC 60721 (dust, chemical / biological pollution, wind, precipitation, fire exposure)
Transport classification	UN 3480 - Class 9
Transport regulation compliance	UN 3480 - ST/SG/AC.10/11 Rev 5 § 38.3
Marking	CE
Directives	ROHS, REACH, WEEE
Manufacturing plants	ISO 9001, QS 9000, ISO 14000
Noise	56 dB at 2 m

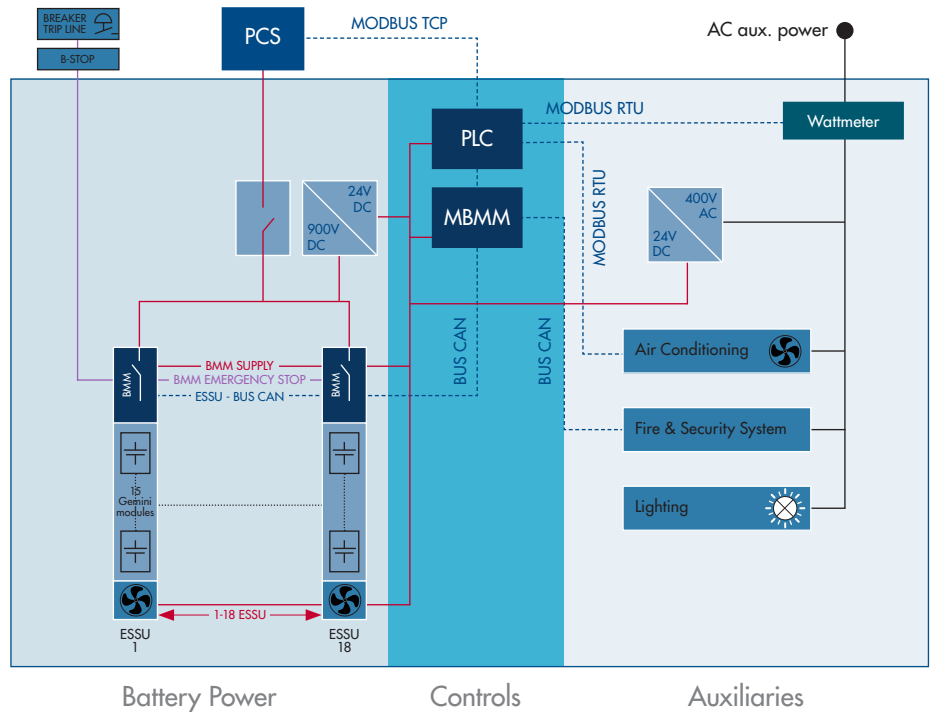

## Battery System Architecture

- 18 Energy Storage System Units (ESSU)
  - 30 Synerion modules in series
  - One Battery Management Module (BMM)
- Distribution cabinet for 2.5 MW DC power output
  - Communication interface via MODBUS TCP (other protocols are optional)
  - Disconnect switch
- Master Battery Management Module (MBMM)
- Programmable Logic Controller (PLC)
- Two auxiliary power supplies
  - 400V AC for HVAC, FSS, lighting
  - 24V DC for electronics and fans, internal DC self-supply available
- Ground fault detection function (optional)
- External emergency stop



## Saft

Transportation, Telecom & Grid  
 26 quai Charles Pasqua  
 92 300 Levallois-Perret – France  
 Tel. : +33 1 58 63 16 00  
 Fax : +33 1 58 63 16 18  
 www.saftbatteries.com

Doc No.: 21974-0317-2

Edition: March 2017

Data in this document is subject to change without notice and becomes contractual only after written confirmation.

Société par Actions Simplifiée au capital de 31 944 000 €

RCS Bobigny B 383 703 873

Produced in the UK by Arthur Associates Limited