



工業級  
Industrial grade

**NL displacement gas shear features:**

- Shearing capacity: 2.3mm-5.0mm;
- Adjustable distance: 0-5mm;
- Body specifications: 6 types of body models;
- Displacement design, adjustable cutting edge opening, more tight cutting, better cutting precision and better effect;
- The two-way adjustable design of the slide rail is convenient for positioning and debugging;
- Fine control of shear speed with electronic air proportional valve;
- Suitable for all kinds of workpiece cutting, it is the best cutting choice for the robot arm.

**Application field**

- Toy industry, plastic industry, home appliance industry, 3C industry, automotive interior parts industry.

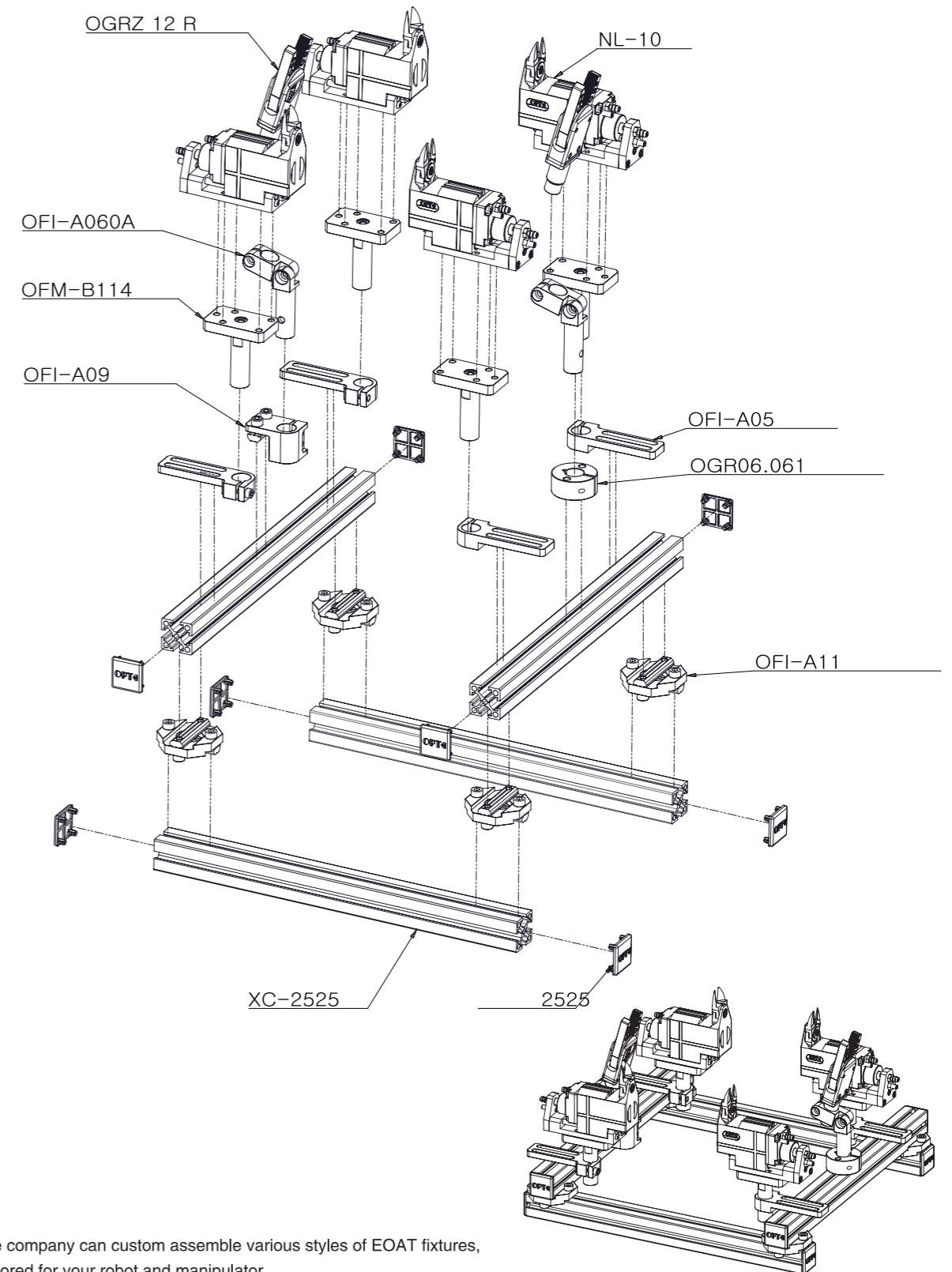
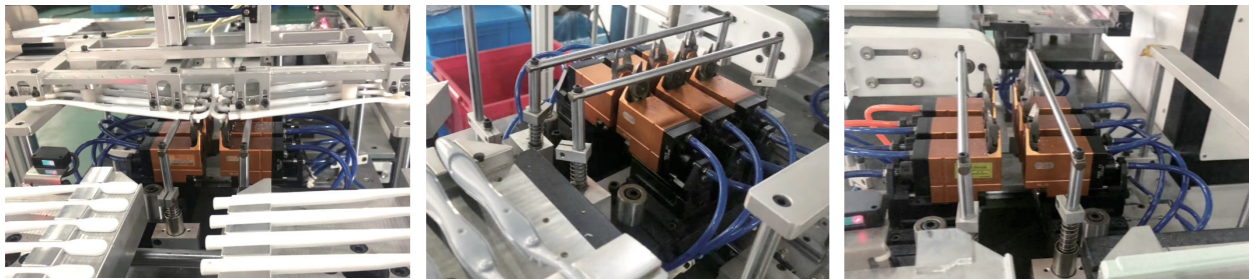

The company can custom assemble various styles of EOAT fixtures, Tailored for your robot and manipulator.

**NL-10**



Model	Air In let (mm)	(cm <sup>3</sup> ) Air wastage cycle	(kgf/cm <sup>2</sup> ) Operation pressure	Weight(g)
NL-10	4	68	4-5	228

NY-10AJ, NY-10AJL, NY-10AE, NY-10AJT, NY-10AD, NY-10AH, NY-10AEG, NY-10AEGL

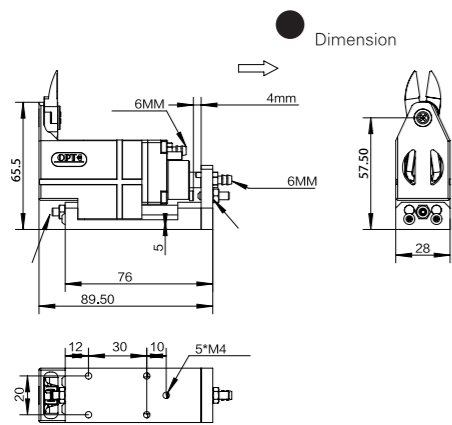

**NL-10R**



Model	Air In let (mm)	(cm <sup>3</sup> ) Air wastage cycle	(kgf/cm <sup>2</sup> ) Operation pressure	Weight(g)
NL-10R	6	68	4-5	228

NY-10RAJ, NY-10RAJL, NY-10AE, NY-10AJT, NY-10AD, NY-10AH, NY-10AEG, NY-10AEGL

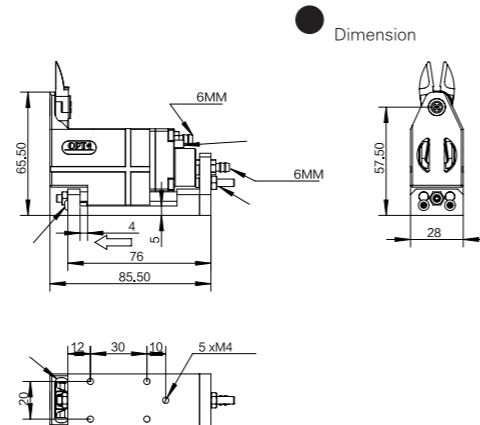

■ Consumable parts



Cutter head screw  
NL10LS



Blade spring  
NL10TH01



Piston  
NL10MFQ



Piston Seal ring  
NL10MFQ01

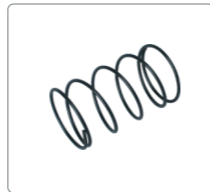

Piston spring  
NL10TH02



Pull out the seal  
NL10MFQ02



Connector  
AP.5002000N01

■ Optional accessories



Mounting plate  
OFM-B114



Cylindrical connecting rod  
OFM-A100



Heavy duty elbow arm  
OFI-A195A



Elbow arm  
OFI-A63A



Clamp leg  
OFI-A94



Clamp leg  
OFI-A94A



Round tube adapter  
OFI-A1020



Round pipe straight joint  
OFI-2020



Cross(Round) joint connector  
OFI-A38



Mounting bracket  
OFI-A07



Heavy duty mounting bracket  
OFI-A205



Slotted angular bracket  
OFI-252



Mounting bracket  
OFI-A10



Mounting mount  
OGR06.062



Hoses  
OPT06x40R

■ Applications

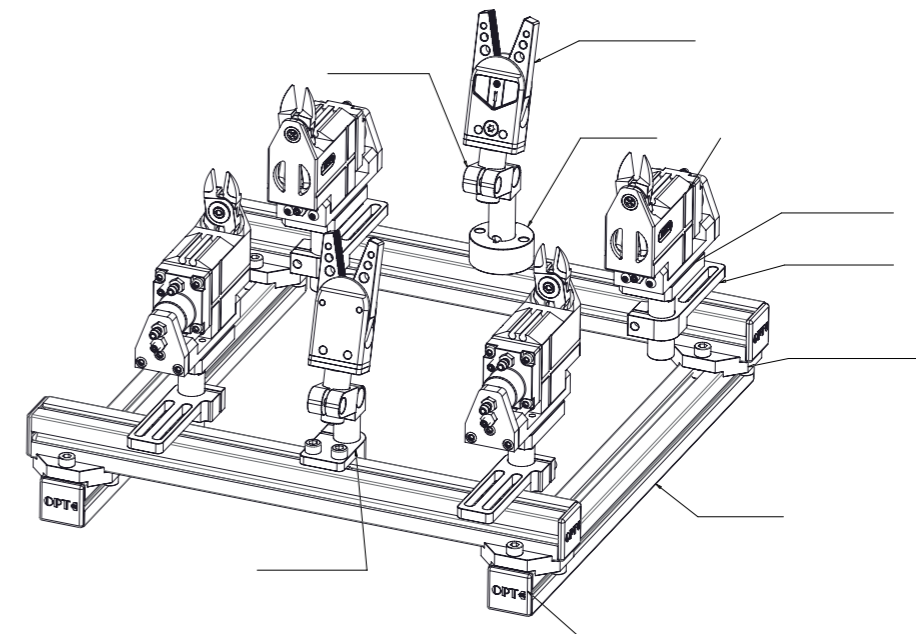

**NL-15**



Model	Air in let (mm)	(cm <sup>3</sup> ) Air wastage cycle	(kgf/cm <sup>2</sup> ) Operation pressure	Weight(g)
NL-15	6	136	4-5	296

NY-15AJ, NY-15AJL, NY-15AUT, NY-15AE

**NL-15R**



Model	Air in let (mm)	(cm <sup>3</sup> ) Air wastage cycle	(kgf/cm <sup>2</sup> ) Operation pressure	Weight(g)
NL-15R	6	136	4-5	296

NY-15RAJ, NY-15RAJL, NY-15AUT, NY-15AE

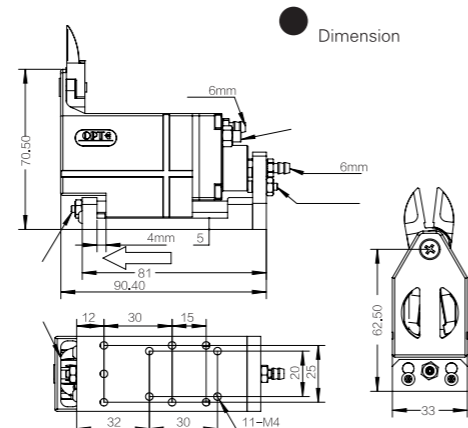
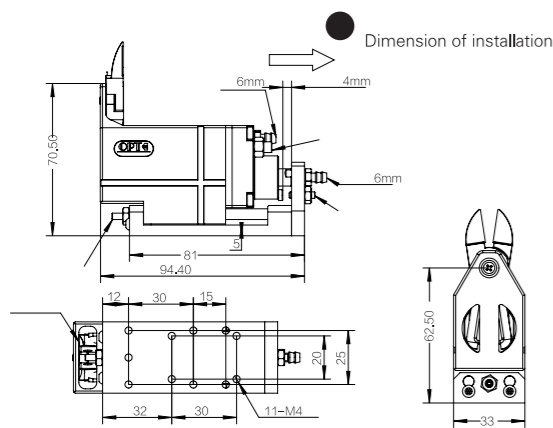

Consumable parts



Cutter head screw  
NL15LS

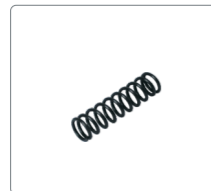

Blade spring  
NL15TH01



Piston  
NL15MFQ



Piston Seal ring  
NL15MFQ01

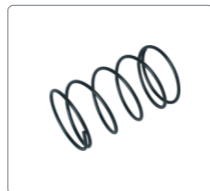

Piston spring  
NL15TH02

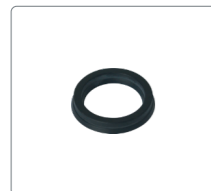

Pull out the seal  
NL15MFQ02



Connector  
AP.5002000N01

Optional accessories



Mounting plate  
OFM-B115



Cylindrical connecting rod  
OFI-A100



Heavy duty elbow arm  
OFI-A195A



Elbow arm  
OFI-A63A



Clamp leg  
OFI-A94



Clamp leg  
OFI-A94A



Round tube adapter  
OFI-A1020



Round pipe straight joint  
OFI-2020



Cross(Round) joint connector  
OFI-A38



Mounting bracket  
OFI-A07



Heavy duty mounting bracket  
OFI-A205



Slotted angular bracket  
OFI-252



Mounting bracket  
OFI-A09



Mounting mount  
OGR06.062



Hoses  
OPT06x40R

Applications

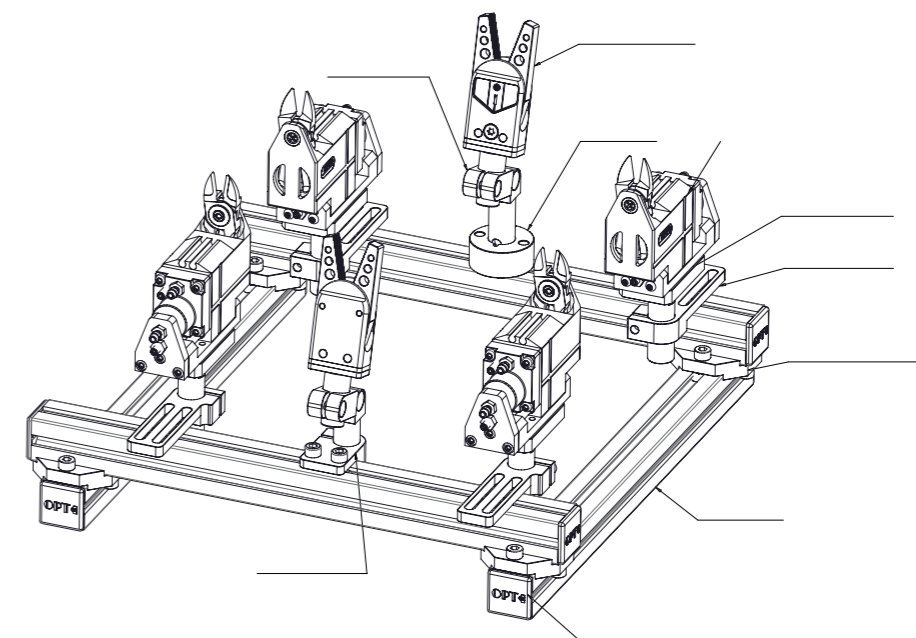

**NL-25**



Model	AirIn let (mm)	(cm <sup>3</sup> ) Air wastage cycle	(kgf/cm <sup>2</sup> ) Operation pressure	Weight(g)
NL-25	6	184	4-5	426

NY-25AJ,NY-25AJL,NY-25AE

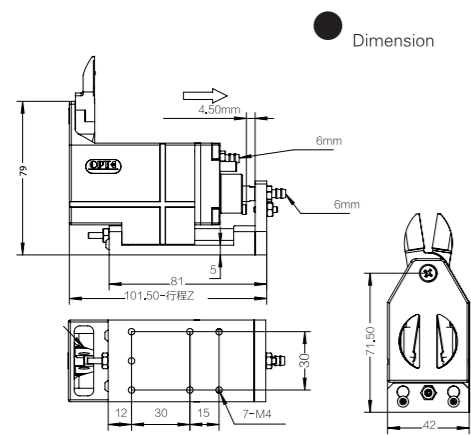

**NL-25R**



Model	AirIn let (mm)	(cm <sup>3</sup> ) Air wastage cycle	(kgf/cm <sup>2</sup> ) Operation pressure	Weight(g)
NL-25R	6	184	4-5	426

适配刀头: NY-25RAJ, NY-25RAJL,NY-25AE

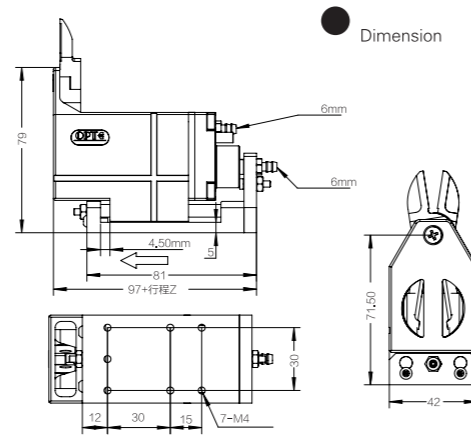

■ Consumable pare parts



Cutter head screw  
NL25LS

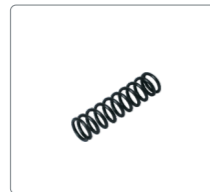

Blade spring  
NL25TH01



Piston  
NL25MFQ



Piston Seal ring  
NL25MFQ01

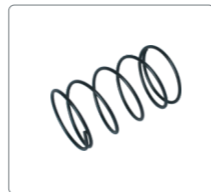

Piston spring  
NL25TH02



Pull out the seal  
NL25MFQ02



Connector  
AP.5002000N01

■ Optional accessories



Mounting plate  
OFM-B106



Cylindrical connecting rod  
OFM-A98



Heavy duty elbow arm  
OF-A195A



Elbow arm  
OF-A63A



Clamp leg  
OF-A94



Clamp leg  
OF-A94A



Round tube adapter  
OF-A1020



Round pipe straight joint  
OF-1020



Cross(Round) joint connector  
OF-A38



Mounting bracket  
OF-A07



Heavy duty mounting bracket  
OF-A205



Slotted angular bracket  
OF-252



Mounting bracket  
OF-A09



Mounting mount  
OGR06.062



Hoses  
OPT06x40R

Abbreviation for each type of Replaceable blade ST:Standard blade P:Powerful blade F:For plastic only Z:Super hard CR:Cutter blade EP:Shear Y:Pliers SY:Cutting off and pressing A:Customer made PliersS-R:Sharp blade FF:Thin edged blade for plastic

According to different purposes, the company has a variety of types of Replacement Blades for you to choose from

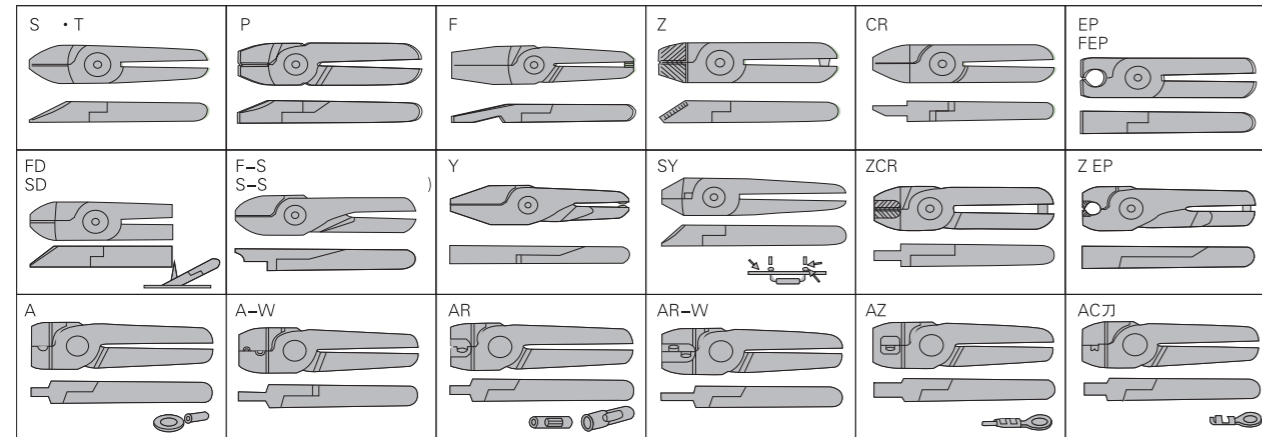

**Standard replacement knife shape size**

**S Standard knife**

(1) (mm)

	a	b	c	f°
S20	24	12	3	25
S20.1	24	12	3.2	25
S2	24	12	3	25
S2.1	24	12	3.2	25
S4	27	14	5	25
S4.1	27	12	5	25
S5	35	17	6.5	30
S7P	43	20	7	30

**S-S Standard knife (knife) With super hard carbon steel**

(3) (mm)

	a	b	c
S20S	24	12	3
S2S	24	12	3
S4S	27	13	5
S5S	35	17	6.5
※ ZS2S	24	12	3
※ ZS4S	27	13	5
※ ZS5S	35	17	6.5

**F-P Strong knife With super hard carbon steel**

(5) (mm)

	a	b	c	f°
F9P	66	38	16	15
FD9P	60	27	14	14
F9PS	66	35	16	0
F9PB	66	32	16	25
F9PC	99	32	13	30
※ ZS2	24	12	3	25
※ ZS4	27	14	5	25
※ ZS5	35	17	6.5	30
※ ZS7P	43	20	7	30

**F-CT Shear knife With super hard carbon steel**

(7) (mm)

	a	b	c
F10CT	24	7	3
F1CT	24	7	3
F3CT	25	9	5
F5CT	28	12	7
F5CTL	44	12	9
F5CTLG	44	15	9
F9CT	35	17	6.5
F9LCT	50	17	12

**F-S Special resin plate cutter With super hard carbon steel**

(6) (mm)

	a	b	c	f°
F10S	24	12	3	
F1S	24	12	3	
F3S	27	12.5	5	
F5S	35	16	8.5	
F2504S	43	16	11	
F9PS	66	35	16	

**F-ZF Resin special knife With super hard carbon steel**

(8) (mm)

	a	b	c	f°
F10	24	12	3	15
F1	24	12	3	15
F3	27	12.5	5	25
F5	35	15	8.5	15

**F-LS Long (special resin) With super hard carbon steel**

(10) (mm)

	a	b	c
F3LS	50	25	8
F5LS	65	23	14

Dimension is only for reference, There are more or less change in advance

Biggest strength are according to your job specific situation at least one to replace the blade. Following, Published custom made replaceable blade order process. OPT have thousands of replaceable blades.

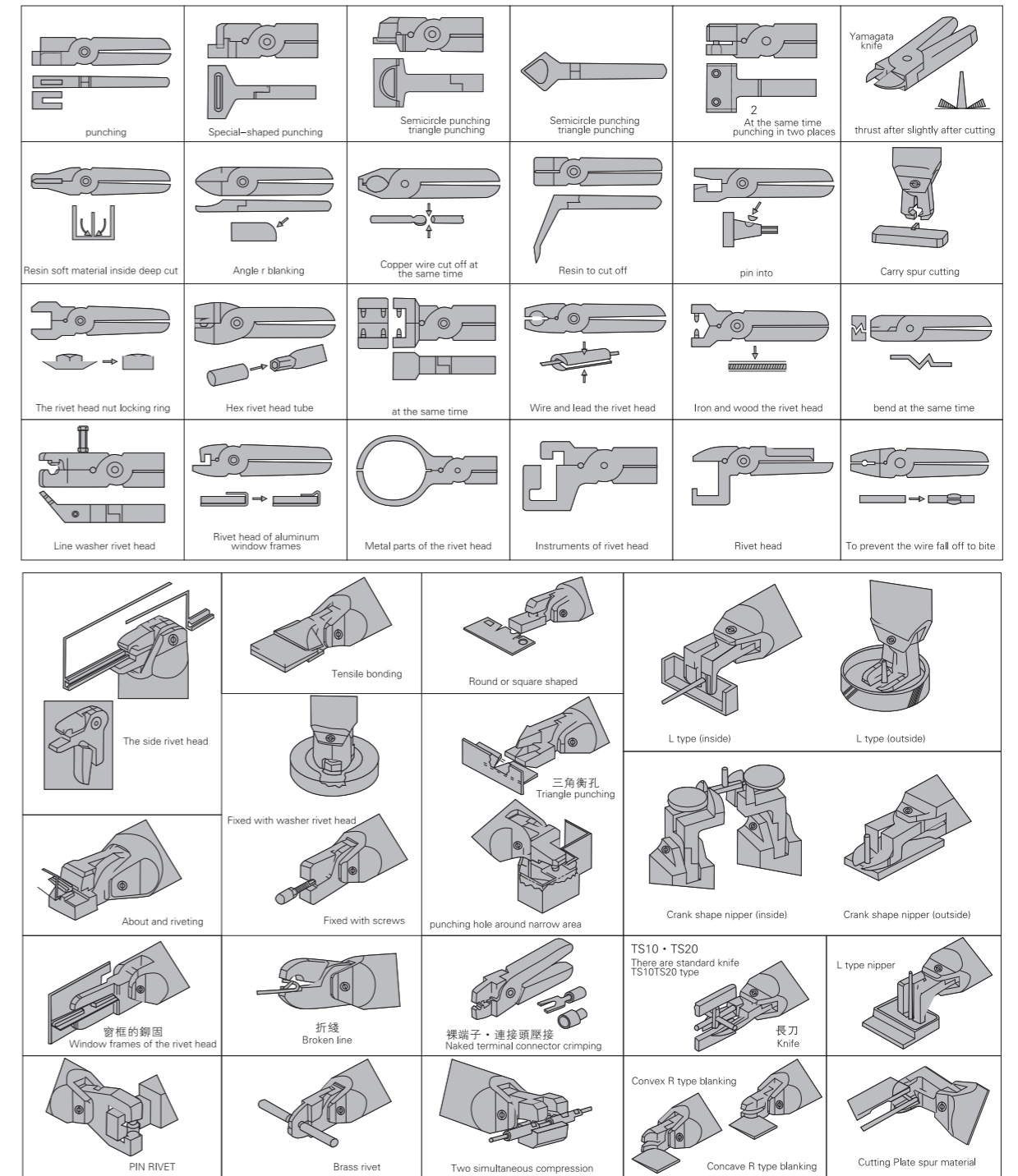

Custom order of Replacement Blades Please provide samples of drawings or samples. We will replace the blade through the means to inform your company has business tools trading with your company's quotation and delivery time