

Foodservice Equipment • Material Handling, Healthcare & Cleanroom Equipment • Retail Display

Utility Sinks

Square Corner Construction



Item #:	_____
Model #:	_____
Project #:	_____
SIS #:	_____

Optional Accessories	Model #	Qty.
Faucet		
Detachable drainboard		
Lever waste		
Lever waste with overflow		
Stainless steel legs		
Stainless steel feet		



three-compartment utility sink with no drainboards
(shown with optional faucet)

- These functional sinks provide the user with a basic unit for numerous applications when NSF construction is not required.
- 16 gauge stainless steel.
- Type 304 series or 430 series construction available.
- Available with detachable or welded drainboards.
- Adjustable bullet feet.
- For NSF- and CSA-approved utility sinks, add prefix “N-” to model number.
Example: **N-2460-2-16/3**

Spec sheets available for viewing, printing or downloading from our online literature library at www.eaglegrp.com

For custom configuration or fabrication needs, contact our **SpecFAB Division**.
Phone: (302) 653-3000. FAX: (302) 653-3091.
E-mail: specfab@eaglegrp.com

Utility Sinks

Design and Construction Features

- A basic sink designed for numerous applications when NSF approval is not required.
- All partitions have 5/8" (16mm)-wide rolled top edge.
- Leg locations fall directly under sink bowls providing increased stability and maximum weight support where needed construction features.
- Entire assembly is fused, welded and planished providing a one-piece seamless sink unit.
- Welded areas are high-speed belt blended to match adjacent surfaces with continuity of satin finish.
- Leg gussets are welded to a die-cut heavy-gauge reinforcing channel.
- All outside corners of sink assembly are bullnosed to provide safe, clean edges.
- Water supply is 1/2" (13mm) IPS for hot and cold lines.
- Faucet holes are punched on 8" (203mm) centers; two sets of faucet holes are required where indicated on schedule.
- Faucets are available as options.
- Basket-type waste drains are 1 1/2" (38mm) IPS and included.
- Sink – 16 gauge type 304 or 430 stainless steel.
- Legs – 1 1/8" (41mm)-diameter heavy-gauge galvanized tubing with plated 12-gauge gussets and high-impact corrosion-resistant fully adjustable bullet feet.
- For NSF- and CSA-approved utility sinks, add prefix "N-" to model number. Example: N-2460-2-16/3

One-Compartment Sinks

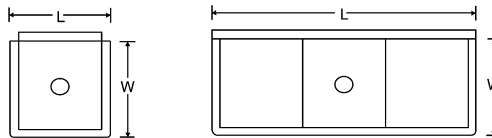

bowl size width x length in. mm		drainboard length in. mm		weight lbs. kg		overall size width x length in. mm		16 gauge type 430 stainless steel model #	16 gauge type 304 stainless steel model #
One Compartment, No Drainboards									
18" x 18"	457 x 457	n/a		53	24.0	21 1/2" x 21"	546 x 533	1818-1-16/4	1818-1-16/3
18" x 24"	457 x 610	n/a		56	25.4	21 1/2" x 27"	546 x 686	1824-1-16/4	1824-1-16/3
21" x 18"	533 x 457	n/a		56	25.4	24 1/2" x 21"	622 x 533	2118-1-16/4	2118-1-16/3
21" x 24"	533 x 610	n/a		59	26.8	24 1/2" x 27"	622 x 686	2124-1-16/4	2124-1-16/3
21" x 36"	533 x 914	n/a		65	29.5	24 1/2" x 39"	622 x 991	2136-1-16/4	2136-1-16/3
24" x 24"	610 x 610	n/a		60	27.2	27 1/2" x 27"	699 x 686	2424-1-16/4	2424-1-16/3
24" x 36"	610 x 914	n/a		68	30.8	27 1/2" x 39"	699 x 991	2436-1-16/4	2436-1-16/3
One Compartment, Double Drainboards									
21" x 24"	533 x 610	18"	457	99	44.9	24 1/2" x 63"	622 x 1600	2124-1-18-16/4	2124-1-18-16/3
24" x 24"	610 x 610	24"	610	108	49.0	27 1/2" x 75"	699 x 1905	2424-1-24-16/4	2424-1-24-16/3

Two-Compartment Sinks

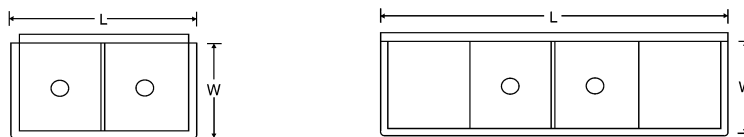

bowl size width x length in. mm		drainboard length in. mm		weight lbs. kg		overall size width x length in. mm		16 gauge type 430 stainless steel model #	16 gauge type 304 stainless steel model #
Two Compartments, No Drainboards									
18" x 18"	457 x 457	n/a		75	34.0	21 1/2" x 39"	546 x 991	1836-2-16/4	1836-2-16/3
18" x 24"	457 x 610	n/a		80	36.3	21 1/2" x 51"	546 x 1295	1848-2-16/4	1848-2-16/3
21" x 18"	533 x 457	n/a		80	36.3	24 1/2" x 39"	622 x 991	2136-2-16/4	2136-2-16/3
21" x 24"	533 x 610	n/a		85	38.6	24 1/2" x 51"	622 x 1295	2148-2-16/4	2148-2-16/3
24" x 24"	610 x 610	n/a		89	40.4	27 1/2" x 51"	699 x 1295	2448-2-16/4	2448-2-16/3
24" x 30"	610 x 762	n/a		95	43.1	27 1/2" x 63"	699 x 1600	2460-2-16/4	2460-2-16/3
Two Compartments, Double Drainboards									
21" x 18"	533 x 457	18"	457	120	54.4	24 1/2" x 75"	622 x 1905	2136-2-18-16/4	2136-2-18-16/3
24" x 24"	610 x 610	24"	610	139	63.1	27 1/2" x 99"	699 x 2515	2448-2-24-16/4	2448-2-24-16/3

Utility Sinks

Design and Construction Features

- 16 gauge stainless steel construction.
- 304 Series and 430 Series construction available.
- 8" (203mm) splash – 2" (51mm) return to wall on 45° angle with 1" (25mm) upturn.
- Faucet holes – 1½" (29mm) on 8" (203mm) centers for sinks up to 54" (1372mm) long; 2 sets of holes on longer models.
- 14" (356mm)-deep compartments.
- 1½" (38mm) rolled rim – front and ends.
- 1¾" (41mm) galvanized legs.
- Adjustable bullet feet.
- 34½" to 35½" (876 to 902mm) working height.
- Crumb cup strainer standard equipment – ¾" (89mm) diameter hole.
- Available with detachable or welded drainboards.
- Legs have 1" (25mm) adjustment.
- For NSF- and CSA-approved utility sinks, add prefix "N-" to model number. Example: **N-2472-4-16/3**

Three-Compartment Sinks

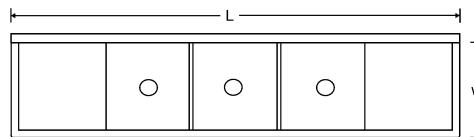
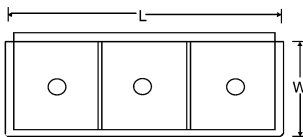

bowl size		drainboard length		weight		overall size		16 gauge type 430	16 gauge type 304
width	length	in.	mm	lbs.	kg	width	length	stainless steel	stainless steel
in.	mm	in.	mm			in.	mm	model #	model #
Three Compartments, No Drainboards									
18" x 12"	457 x 305	n/a		79	35.8	21½" x 39"	546 x 991	1836-3-16/4	1836-3-16/3
18" x 16"	457 x 406	n/a		90	40.8	21½" x 51"	546 x 1295	1848-3-16/4	1848-3-16/3
18" x 18"	457 x 457	n/a		97	44.0	21½" x 57"	546 x 1448	1854-3-16/4	1854-3-16/3
21" x 12"	533 x 305	n/a		85	38.6	24½" x 39"	622 x 991	2136-3-16/4	2136-3-16/3
21" x 16"	533 x 406	n/a		87	39.5	24½" x 51"	622 x 1295	2148-3-16/4	2148-3-16/3
21" x 18"	533 x 457	n/a		100	45.4	24½" x 57"	622 x 1448	2154-3-16/4	2154-3-16/3
21" x 20"	533 x 508	n/a		110	49.9	24½" x 63"	622 x 1600	2160-3-16/4*	2160-3-16/3*
24" x 16"	610 x 406	n/a		92	41.7	27½" x 51"	699 x 1295	2448-3-16/4	2448-3-16/3
24" x 20"	610 x 508	n/a		115	52.2	27½" x 63"	699 x 1600	2460-3-16/4*	2460-3-16/3*
24" x 24"	610 x 610	n/a		125	56.7	27½" x 75"	699 x 1905	2472-3-16/4*	2472-3-16/3*
Three Compartments, Double Drainboards									
21" x 12"	533 x 305	18"	457	125	56.7	24½" x 75"	622 x 1905	2136-3-18-16/4	2136-3-18-16/3
21" x 16"	533 x 406	18"	457	127	57.6	27½" x 87"	699 x 2210	2148-3-18-16/4	2148-3-18-16/3
21" x 18"	533 x 457	18"	457	140	63.5	24½" x 93"	622 x 1600	2154-3-18-16/4	2154-3-18-16/3
24" x 24"	610 x 610	24"	610	175	79.4	27½" x 123"	699 x 1905	2472-3-24-16/4*	2472-3-24-16/3*

* Requires two sets of faucet holes.

Four-Compartment Sinks

All four-compartment sinks are provided with two sets of faucet holes.

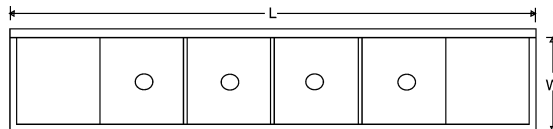
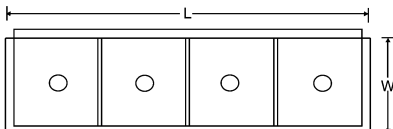

bowl size		drainboard length		weight		overall size		16 gauge type 430	16 gauge type 304
width	length	in.	mm	lbs.	kg	width	length	stainless steel	stainless steel
in.	mm	in.	mm			in.	mm	model #	model #
Four Compartments, No Drainboards									
18" x 18"	457 x 457	n/a		110	49.9	21½" x 75"	546 x 1905	1872-4-16/4	1872-4-16/3
21" x 18"	533 x 457	n/a		115	52.2	24½" x 75"	622 x 1905	2172-4-16/4	2172-4-16/3
24" x 18"	610 x 457	n/a		125	56.7	27½" x 75"	699 x 1905	2472-4-16/4	2472-4-16/3
Four Compartments, Double Drainboards									
21" x 18"	533 x 457	18"	457	155	70.3	24½" x 111"	622 x 2819	2172-4-18-16/4	2172-4-18-16/3

Utility Sinks

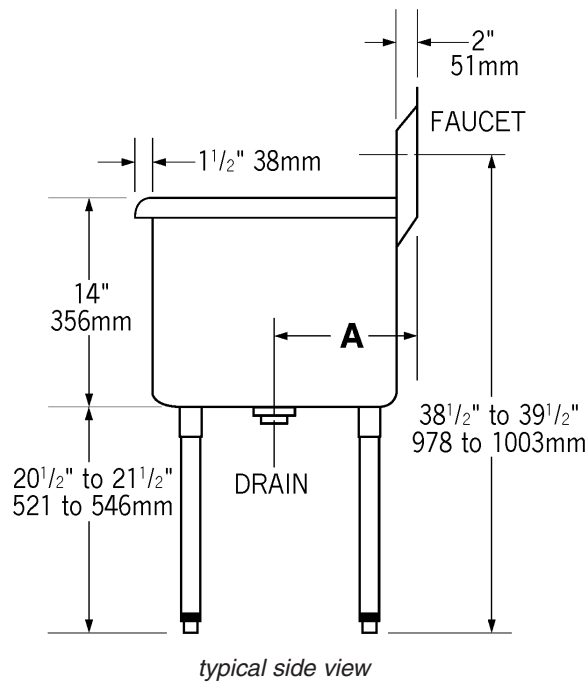

Drain Location for Rough-In			
bowl size		Dimension A	
in.	mm	in.	mm
18"	457	11"	279
21"	533	12½"	318
24"	610	14"	356
30"	762	17"	432

Optional Detachable Drainboards for Utility Sinks

- Unique die-stamped rolled-rim construction is fully reversible — can be used for left- or right-hand operation.
- Features easy clip-on installation with two support brackets that bolt to sink gussets.
- Available in heavy gauge type 430 or 304 series stainless steel.
- Drainboards 30" (762mm) long are furnished with legs.

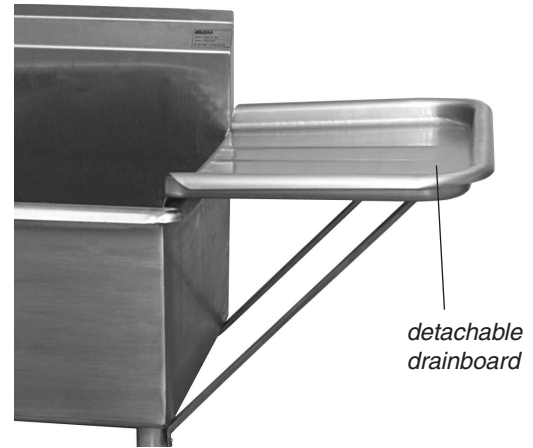

width (front-to-back) x length (side-to-side)		weight	16 gauge type 430		16 gauge type 304	
			stainless steel	model #	stainless steel	model #
in.	mm	lbs.	kg			
18" x 18"	457 x 457	19	8.6	18X18 RRDEDB		18X18 RRDEDB-16/3
18" x 24"	457 x 610	23	10.4	18X24 RRDEDB		18X24 RRDEDB-16/3
18" x 30"	457 x 762	27	12.2	18X30 RRDEDB		18X30 RRDEDB-16/3
21" x 18"	533 x 457	20	9.0	21X18 RRDEDB		21X18 RRDEDB-16/3
21" x 24"	533 x 610	24	10.9	21X24 RRDEDB		21X24 RRDEDB-16/3
21" x 30"	533 x 762	28	12.7	21X30 RRDEDB		21X30 RRDEDB-16/3
24" x 18"	610 x 457	21	9.5	24X18 RRDEDB		24X18 RRDEDB-16/3
24" x 24"	610 x 610	25	11.3	24X24 RRDEDB		24X24 RRDEDB-16/3
24" x 30"	610 x 762	29	13.2	24X30 RRDEDB		24X30 RRDEDB-16/3