



# PACK EXPO Connects 2020

COMPREHENSIVE POST SHOW REPORT

**Diana Hunter**

Sr. Creative Services Manager

December 2, 2020

# CONTENTS

## Show Overview

### Showroom Views

- Stats By Category
- Featured Solutions Gallery
- Live Product Demos
- Chats
- Collateral
- Personalized Registration Page

### Leads

- Lead Details
- ROI History

## Marketing & Promotion

- Print Campaign
- Web Advertising
- Sponsored & Lead Generation E-blasts
- Customer Invite Program
- Social Media

### Collateral

- Download Summary
- Download Details

### Virtual 3D Booth

### Next Year's Show

# SHOW OVERVIEW

4799

## SHOWROOM VIEWS

Number of times our company listing has been viewed on the directory and floor plan (count does not represent unique visits)

9

## LINKS TO WEBSITE

Number of times someone selected the URL in our listing and clicked through to our company website

586

## AGENDA ADDS

Number of times we were added to an attendee's agenda (including WestRock personnel)

473

## LEADS

Number of individuals who agreed to share their contact information with us (excludes WestRock personnel and competitors)

This year's PACK EXPO was a virtual multi-channel marketing event structured around live product demonstrations, chats (group and 1:1) and lead generation opportunities. Aptly called PACK EXPO Connects, the event was held November 9-13, 2020.

You can still visit WestRock's online showroom at [pe.show/158](https://pe.show/158). The site will remain active through the end of March 2021.

# SHOWROOM VIEWS

- STATS BY CATEGORY
- FEATURED SOLUTIONS GALLERY
- LIVE PRODUCT DEMOS
- CHATS
- COLLATERAL
- PERSONALIZED REGISTRATION PAGE

# STATS BY CATEGORY

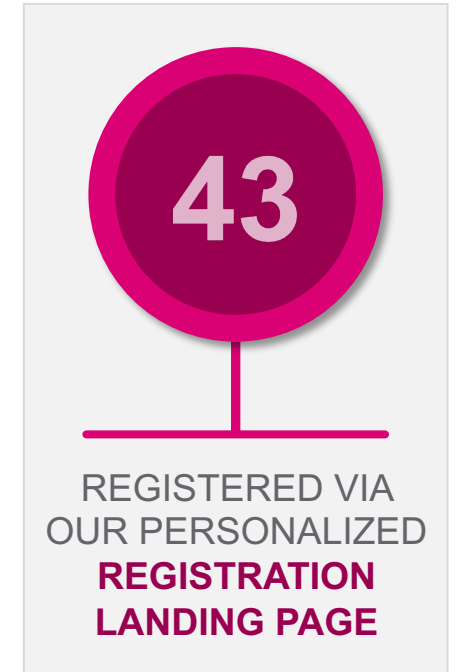
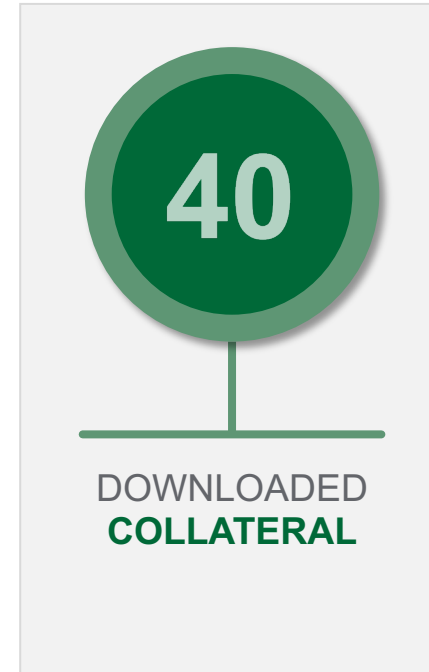
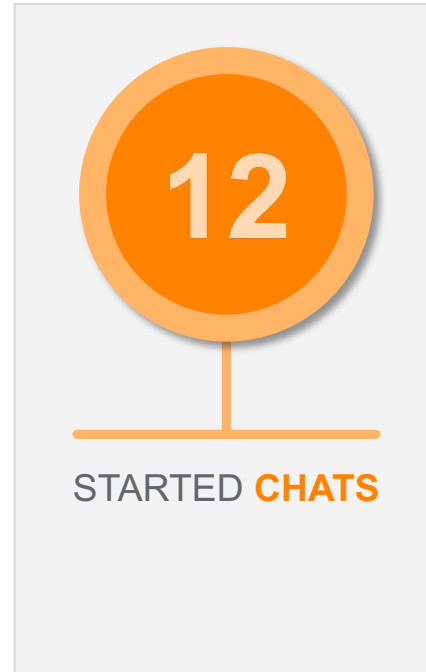
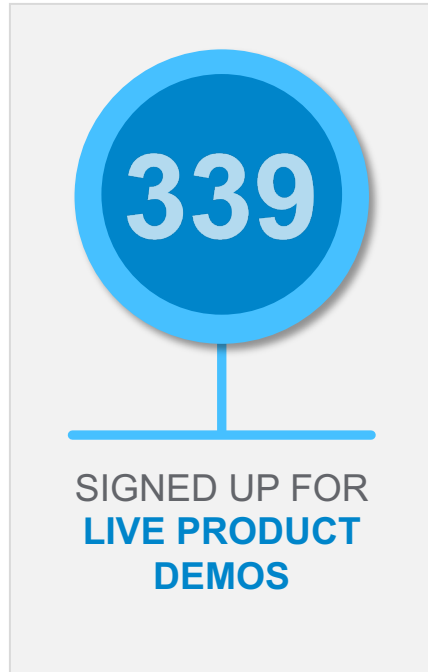

## Automatic lead capture provided information on attendees who:

- Added our showroom to their planner or “favorited” anything related to our company
- Clicked on a demo to watch it
- Chatted with our specialists or requested a private meeting
- Downloaded collateral
- Registered for the event through our personalized registration landing page

# FEATURED SOLUTIONS GALLERY

November 9-13, 2020

**LIVE. VIRTUAL. REIMAGINED.**

WestRock WestRock

1 of 8

## Cluster Pak<sup>®</sup> eMerge™ Combo

**+** Improve Efficiency with Integrated End-of-Line Solutions

**New**

WestRock understands the complexity of your supply chain and is dedicated to helping you operate efficiently and deliver consistently to meet market demand. With the broader portfolio of primary secondary and tertiary packaging solutions, enabled by high performance automation, WestRock can partner with you to solve your challenges.

Looking to improve efficiency with integrated end-of-line solutions? Introducing the CP eMerge™ Combo, WestRock's newest automation technology for food bowls that combines sustainable secondary and tertiary packaging into one system. The single operator end of line solution manages multiple SKUs and minimizes downtime by allowing for quick changeover between a range of bowl and tray. The integrated control design is uniquely valuable for those with footprint constraints.

**Complexity, simplified.**

Learn more about how consumers respond to this packaging solution.

VISIT OUR VIRTUAL IN-PARTNER

CP eMerge™ Combo

24 Views

November 9-13, 2020

**LIVE. VIRTUAL. REIMAGINED.**

WestRock WestRock

2 of 8

## CanCollar<sup>®</sup> Fortuna™

**+** Looking for Fiber Alternatives to Plastic Multipacks?

**New**

At WestRock, we connect people to products through sustainable packaging, innovation and collaboration are central to our purpose and our approach. With many of our customers around the world seeking sustainable packaging innovation, we are partnering with them to offer differentiated fiber based solutions.

Specifically designed for beverage supply chains and engineered to efficiently run on automation equipment, CanCollar<sup>®</sup> is a family of fiber based packaging solutions for multipackaging beverage cans with a minimal amount of sustainable packaging materials. CanCollar<sup>®</sup> Fortuna™ is a high speed automation solution for spooling CanCollar and a range of other minimal, glue-free paperboard multipack designs. This solution demonstrates our focus on developing flexible fit for purpose solutions that help our customers address their sustainable packaging goals while managing the cost and risk of this transformation.

**Fast. Flexible. Fortuna.**

CanCollar<sup>®</sup> Fortuna™

7 Views

November 9-13, 2020

**LIVE. VIRTUAL. REIMAGINED.**

WestRock WestRock

7 of 8

## CONNECTED AUTOMATION

**+** Improve Uptime and Efficiency with Connected Automation

**New**

Leveraging AI, augmented reality and remote diagnostics, WestRock's Connected Automation platform delivers the information you need to drive ongoing performance improvement and maximize your operator's productivity.

WestRock's Connected Automation platform provides robust data analysis and support functionality to improve your uptime and efficiency, reduce your maintenance and operating costs, and extend the lifetime of your assets.

Connected Automation

1 View

# FEATURED SOLUTIONS GALLERY

E-commerce Packaging

11 Views

BoxSizer® Right-Sizing Technology

0 Views

Pak On Demand™ Pouch System

4 Views

# FEATURED SOLUTIONS GALLERY

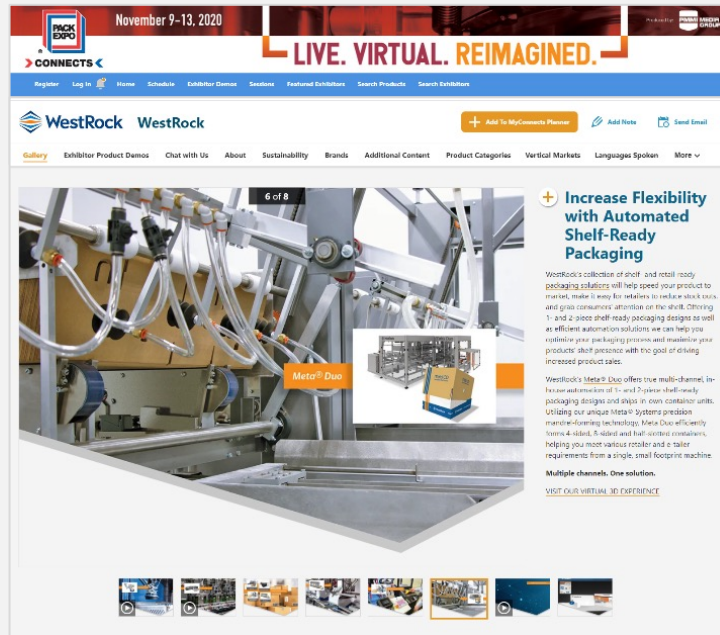

Meta® Duo

5 Views

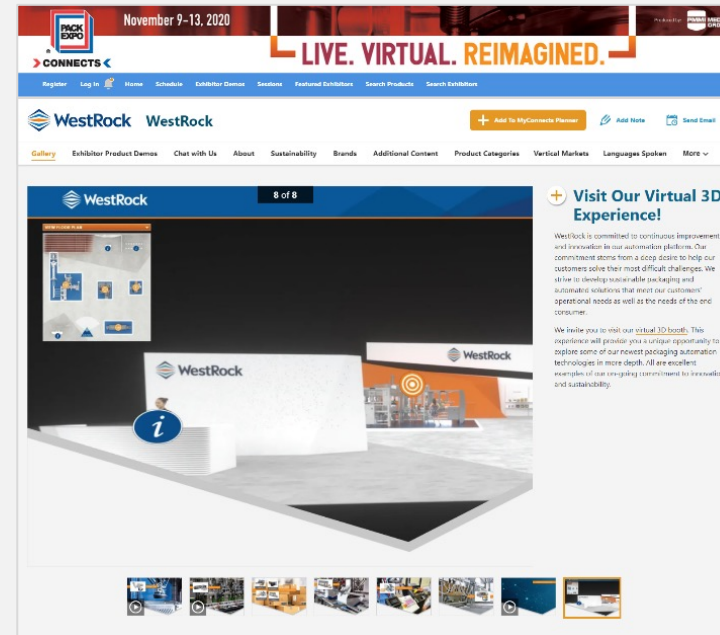

Virtual 3D Booth

2 Views

52

PRODUCT VIEWS

Refer to slides 39-40 for additional information regarding our Virtual 3D Booth.



# LIVE PRODUCT DEMOS

MONDAY 11/9*		TUESDAY 11/10		WEDNESDAY 11/11		THURSDAY 11/12	
12:30 PM CST	2:15 PM CST	12:15 PM CST	2:00 PM CST	12:15 PM CST	2:00 PM CST	12:15 PM CST	2:00 PM CST
CP eMerge™ Combo	CanCollar® Fortuna™	BoxSizer® Right-Sizing Technology	CP eMerge™ Combo	CanCollar® Fortuna™	BoxSizer® Right-Sizing Technology	CP eMerge™ Combo	BoxSizer® Right-Sizing Technology
<b>58</b>	<b>43</b>	<b>46</b>	<b>41</b>	<b>46</b>	<b>38</b>	<b>31</b>	<b>36</b>

**339**

\*Technical difficulties with the show's platform resulted in all live demos being cancelled Monday.

## LIVE DEMO REGISTRATIONS



# COLLATERAL DOWNLOADS

### Brands

[BoxSizer® Intelligent Right-Sizing Technology](#) | 
 [CanCollar® Fortuna™](#) | 
 [CP eMerge™ Combo](#) | 
 [Meta® Systems](#) | 
 [Pak On Demand™ Pouch System](#)

### Additional Content

<p>+ BROCHURE <a href="#">BoxSizer® Right-Sizing Technology</a></p> <p>+ BROCHURE <a href="#">CP eMerge™ Combo EOL Solution</a></p> <p>+ BROCHURE <a href="#">Paperboard Bowl</a></p>	<p>+ BROCHURE <a href="#">CanCollar® Fortuna™</a></p> <p>+ BROCHURE <a href="#">Meta® Duo In-House Channel Automation</a></p> <p>✓ BROCHURE <a href="#">Wraparound Case Packer</a></p>	<p>+ BROCHURE <a href="#">CJ Frozen Food Case Study</a></p> <p>+ BROCHURE <a href="#">Pak On Demand™ Pouch System</a></p>
---	--	---

### Product Categories

<p><a href="#">CARTONING MACHINES &gt; Carton Tray Erect / Load / Seal Machine</a></p> <p><a href="#">CASE / TRAY SEALING MACHINES &gt; Case Taping Machine</a></p> <p><a href="#">CASE GROUP / LOAD AND CLOSE / SEAL MACHINE &gt; Case / Tray Multipacking Machine</a></p> <p><a href="#">CONVERTING MACHINES - CONTAINER / MATERIAL MANUFACTURE &gt; Box Making Machine</a></p> <p><a href="#">PACKAGING CONTAINERS &gt; Point of Purchase (POP) Displays</a></p> <p><a href="#">PACKAGING MATERIAL &gt; Paper / Paperboard - Corrugated Paperboard</a></p> <p><a href="#">PACKAGING MATERIAL &gt; Paper / Paperboard - Specialty Paper</a></p>	<p><a href="#">CARTONING MACHINES &gt; Carton Wrap-around Cartoner / Sleeveing / Mandrel Form / Fill / Seal Machine</a></p> <p><a href="#">CASE ERECTING / TRAY FORMING MACHINES &gt; Case Erecting Machine</a></p> <p><a href="#">CASE GROUP / LOAD AND CLOSE / SEAL MACHINE &gt; Case Erect, Fill and Close Machine</a></p> <p><a href="#">PACKAGING / PROCESSING SERVICES &gt; Sustainable</a></p> <p><a href="#">PACKAGING CONTAINERS &gt; Retail Ready</a></p> <p><a href="#">PACKAGING MATERIAL &gt; Paper / Paperboard - Kraft Paperboard</a></p>	<p><a href="#">CASE / TRAY SEALING MACHINES &gt; Case Gluing Machine</a></p> <p><a href="#">CASE ERECTING / TRAY FORMING MACHINES &gt; Tray Forming Erecting Machine</a></p> <p><a href="#">CASE GROUP / LOAD AND CLOSE / SEAL MACHINE &gt; Wraparound Case Packing Machine</a></p> <p><a href="#">PACKAGING CONTAINERS &gt; Box / Carton / Case</a></p> <p><a href="#">PACKAGING MATERIAL &gt; Paper / Paperboard</a></p> <p><a href="#">PACKAGING MATERIAL &gt; Paper / Paperboard - Paperboard</a></p>
---	--	---

40

DOWNLOADS

# COLLATERAL DOWNLOADS

## DETAILS



### Cluster-Pak® eMerge™ Combo

Integrated end of line solution

**WestRock Cluster-Pak® eMerge™** is a fully integrated end of the line solution delivering superior value for food/bev and tray applications.



**Lower Total Cost**

- Significant material and logistics savings via fully enclosed carton
- High production efficiency and low maintenance
- Flexibility for modular or cost

**Grow Sales**

- Innovative package structure allows for vertical display and premium positioning
- Wide range of already formed packaging formats enable greater channel options
- High efficiency unit-to-capacity to meet demand growth

**Improve Sustainability**

- Reusable, recyclable, material optimized floor solutions (bins, wrap, trolleys)
- Fewer trucks required for inbound logistics of uniquely fully enclosed

**Minimize risk**

- Single point accountability for end of line equipment and service
- Commercial level, commercially available solutions

[westrock.com/automation](http://westrock.com/automation)

**Cluster-Pak® eMerge™ Combo**

Several layout options available, depending on line requirements

- Layout: Inline
- Floor Space: 190x300ft
- Total Length/Width: 230x160ft

Layout: Cellular/90°

- Floor Space: 200x30ft
- Total Length/Width: 230x160ft



Several layout options available, depending on line requirements

- Full Rockwell Allen-Bradley PLC Controls
- Lube-Free machine
- Semi-automatic continuous motion design
- Different product infill and management solutions available depending on product requirements

**Primary Container**

- Bottle and trays
- Height between 30mm & 130mm
- Diameter: 50mm & 230mm

**Package Formats**

- 1 to large sizes
- Option for stacked primaries
- Glued or glue locking closures available

**Package Styles**



**Case Styles**



**Maximum Speeds**

- Up to 150 bottles/tray with configurations pictured above
- Higher speed options available

**Air & Power Requirements**

- Air: 3 Nm³/hr
- Power: 230V/3

**Changeover**

- Semi-automatic changeover of entire system in 45 minutes with 3 operators

**Options**

- Industrial Robot
- Doors Required
- CE certified (Environmental Option)
- Electrical cabinet UL certified (Environmental Option)

New dimensions and specifications subject to change without notice, and pricing dimensions are approximate and not to scale.

**WestRock** For more information, contact WestRock Automation: 4364 Southwest 34th St., Orlando, FL 32811  
Phone: 407.843.1300 • Fax: 407.843.8439 • E-mail: [ap@westrock.com](mailto:ap@westrock.com)

© 2018 WestRock Company. All rights reserved. 11-2018

CP eMerge™ Combo Sell Sheet

7 Downloads



### Wraparound Case Packer

Intermittent Motion



**Features**

- Multiple servo devices provide flexibility for case securing various products
- Inline loading conveyor provides smooth transition between product and case
- Ability for run-in and hold-out case designs
- High performance blank loading system

**Options**

- Washdown capabilities possible with a component upgrade
- Extended hopper
- Automatic filling glue system

**Product Styles**



**Primary Container**

- Bottles, cans, jugs, filling cartons, containers, aseptic packaging, gable top cartons, steered trays and Cluster Pak®
- Length between 4" & 12"
- Width between 4" & 12"
- Depth between 7" & 24"

**Specifications**

**Maximum Speed**

35 CP/Min - product and pattern dependent

**Utility Requirements**

Electrical - 480V3 Ph/3W/2W/3CA  
Air - 1 SCFM at 80 PSI

**Changeover**

Single operator changeover in 80 minutes



[westrock.com/automation](http://westrock.com/automation)

[westrock.com/automation](http://westrock.com/automation)

For more information, contact WestRock Automation: 4364 Southwest 34th St., Orlando, FL 32811  
Phone: 407.843.1300 • Fax: 407.843.8439 • E-mail: [ap@westrock.com](mailto:ap@westrock.com)

© 2018 WestRock Company. All rights reserved. 11-2018

Wraparound Case Packer Spec Sheet

5 Downloads



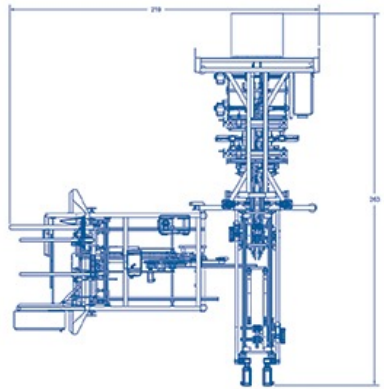

[westrock.com/automation](http://westrock.com/automation)

For more information, contact WestRock Automation: 4364 Southwest 34th St., Orlando, FL 32811  
Phone: 407.843.1300 • Fax: 407.843.8439 • E-mail: [ap@westrock.com](mailto:ap@westrock.com)

© 2018 WestRock Company. All rights reserved. 11-2018

# COLLATERAL DOWNLOADS

## DETAILS

### PACKAGING SOLUTIONS THAT DELIVER FOR CONSUMERS

#### FOCUS ON FUNCTION

"I like to see what I am getting and...also [insert] would be easy to remove."

The most important aspect of packaging to a consumer is the package function

- 30% of consumers consider product visibility important when considering purchasing frozen meals.
- Product visibility should not compromise product protection.
- Consumers agree that a wrap style is more convenient than a fully enclosed package.

**65%** Of consumers are more likely to purchase a frozen meal with product visibility over full coverage alternatives

#### STICK TO SUSTAINABILITY

"Minimal packaging, go earthy."

Consumers are more likely to purchase food packaging with minimal material and minimal package waste

- 64% of consumers agree that a paper food tray is environmentally friendly. This is significantly higher than plastic food trays.
- 55% of consumers prefer paper bowls and trays over plastic for frozen ready meals.
- 44% of consumers agree that paper packaging would have a positive impact on brand likability.

**41 PERCENT** Of consumers look to see if packaging can be recycled when shopping for a new brand of frozen meals.

#### STAND OUT WITH STYLE

"It's paper, but also more fashionable and stylish."

Packaging that creates contrast with the products surrounding it is a proven way to catch consumer's attention

- The average consumer ignores 88% of packaging on the shelf and makes a purchasing decision in under 2.2 seconds.
- Placing your frozen meal in a packaging structure that stands out from the products around it is a proven way to catch a shopper's attention.

**35%** Of consumers have tried something new because the packaging has caught their eye.

SOURCES: WESTROCK FROZEN MEAL BRAND RESPONSE SEPT 2018 & SEPT 2020; SUSTAINABLE PACKAGING STUDY SEPA, THE BY-AND VISIBLE EYE-TRACKING STUDIES; WESTROCK COVID PALSE STUDY, SEPT 2020

Frosty Insights

0 Downloads

### BOWLS THAT CAN TAKE THE HEAT. NOT TO MENTION THE FREEZE.

#### WESTROCK PAPERBOARD BOWL

Made with renewable, sustainably sourced fiber

Printable for premium branding and graphics

Dual-coatable coating that is food-safe and moisture resistant

Outstanding heat sealing performance across a range of techniques

**Product Features:**

- Made with 100% paperboard extruded with PET polymer
- Available in a range of sizes, shapes and depths
- Available with single or multiple cavities
- Compatible with PET flexible lidding film

SUSTAINABILITY	PERFORMANCE	APPEARANCE
Made with renewable, sustainably sourced fiber. Enables a 93% reduction of plastic usage over rigid plastic trays.	Extruded with a barrier polymer engineered to perform from -40°F to 420°F. Withstands the demands of freeze environments. Outstanding heat sealing performance across a range of techniques including hot air, plates and microwave.	Printable surface enables branding and product messaging. Embossable for enhanced branding and premium positioning.

© 2020 WestRock Company. WESTROCK, WestRock and the WestRock logo are trademarks and/or registered trademarks of WestRock Company. All other marks are the property of their respective owners.

**WestRock Paperboard Bowl**

From freezer to oven without missing a beat. That's the advantage you can expect from the WestRock Paperboard Bowl. It's the reliable and sustainable alternative to rigid plastic trays for frozen meals, bakery applications and more.

westrock.com

Paperboard Bowl Sell Sheet

6 Downloads

# COLLATERAL DOWNLOADS

## DETAILS

### Success story:

## OPTIMIZED OPERATIONS

As WestRock, our partnerships are fueled by innovation that supports operating efficiencies and packaging designs that are sustainable, reduce risk, lower total cost, and drive profitable growth for our customers. We have the expertise to go beyond the packaging process to uncover hidden efficiencies that can improve our customer's bottom-line performance. We analyze the entire supply chain from the layout of machines to the way packages are palletized for transport to provide the optimum packaging and automated solutions.

**REDUCE YOUR OPERATING COSTS, NOT YOUR EXPECTATIONS**

**THE CHALLENGE:** CJ Foods, South Korea's largest packaged food company, creates products for consumers' health, happiness, and convenience. As premium ingredients and consumer convenience continues to drive consumers to ready-to-eat food products, CJ Foods needs a partner to help optimize their production and drive margin enhancement opportunities without sacrificing brand positioning or performance.

**THE SOLUTION:** WestRock delivered a robust, end-of-line solution to automate the wrapping of their rice bowls for retail. Our solution enabled flexibility to meet varied and evolving market needs while lowering operating costs through efficiency, speed and strong local service support. The range of possible configurations delivers brand differentiation while the wrap style carton offers bowl visibility, curing convenience and sustainability.



**TOGETHER, WE WIN**

We bring delicious indulgences to the table.

We aim to globalize the taste of Korea through creating balanced taste between Korean cuisine and local preferences to share healthy and convenient lifestyle.

CJ CheilJedang  
Corporate Website



WestRock

## WESTROCK DELIVERS OPERATING EFFICIENCIES, COST SAVINGS, & SUSTAINABILITY

<b>BETTER SUSTAINABILITY</b> 90-98% per bowl plastic reduction vs CPET tray 30-40% material reduction on secondary wrap vs fully enclosed carton Fully recyclable fiber solutions (bowl, wrap, Shelf Ready Packaging) Fewer trucks required for in-bound logistics of wraps vs fully enclosed	<b>LOWER TOTAL COST</b> Material and logistic savings vs fully enclosed carton Higher efficiency in production and lower maintenance Potential to reduce labor – one operator for wrap and tertiary	<b>INCREASED SALES AT RETAIL</b> Innovative package structure allows for vertical display and premium positioning Wider range of SRP formats enable greater channel options Greater efficiency unlocks additional capacity to meet demand growth	<b>MINIMIZED RISK</b> Market-proven designs and automation Single point of accountability for end of line packaging and equipment Integrated combo design is uniquely suitable for those with footprint constraints Field service support as needed
---	--	---	---

### INNOVATION IN FIBER-BASED PACKAGING & EQUIPMENT



WestRock offers fiber primary, secondary and tertiary packaging solutions enabled by end-of-line automation. We develop innovative packaging and equipment solutions that:

- Enable flexibility through reduced changeover times between formats
- Improve line and labor efficiency and reduce space requirements through our combo technology
- Drive continuous improvement by offering transparent asset or fleet performance data and analytics



WestRock

CJ Frozen Food Case Study

3 Downloads

# COLLATERAL DOWNLOADS

## DETAILS



**BOXSIZER®**

### BoxSizer® Intelligent Right-Sizing Technology



**Smaller Boxes. Bigger Savings.**  
Multi award winning BoxSizer® is the only stand-alone e-commerce packaging machine that continuously reduces multiple footprint box sizes. It does this randomly on-demand without stopping for changeovers, making it ideal for B2B and B2C applications. By ensuring optimal DM weight, you lower your carbon footprint and improve sustainability. Not only are packages right-sized, but they keep products secure, neat, and easy to open.

**80%**  
less void fill

**50%**  
less labor required

**30%**  
volume reduction

Average savings based on typical volume of 1 million boxes per year. Typical 40" x 60" x 12" height.

**Benefits:**

- Improve productivity
- Maximize truck space
- Increase efficiency
- Optimize process
- Reduce operating costs

[westrock.com/boxsizer](http://westrock.com/boxsizer)

### How BoxSizer® Works

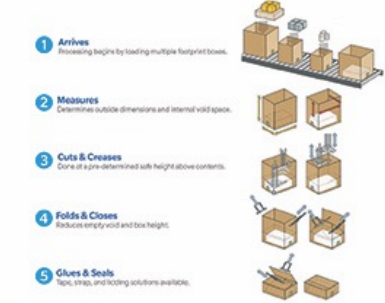

- 1 Arrives**  
Processing begins by loading multiple footprint boxes.
- 2 Measures**  
Determines outside dimensions and internal void space.
- 3 Cuts & Creases**  
Cuts off size determined sub height above contents.
- 4 Folds & Closes**  
Reduces empty void and box height.
- 5 Glues & Seals**  
Tape, straps, and locking solutions available.

**Seamless Integration Options:**

- Integrate to existing lines
- Tailored turnkey solutions



For more information, contact WestRock Automation, 4354 Southwest 34th St., Orlando, FL 32811  
Phone: 407.843.1300 • Fax: 407.843.8419 • E-mail: [ag@westrock.com](mailto:ag@westrock.com)

BoxSizer® Sell Sheet

4 Downloads



**PAK ON DEMAND™**

### Pak On Demand™ Pouch System



- Increase productivity
- 4-to factor that manual packing
- Reduce labor costs
- Eliminate dust fill
- Small footprint

**Efficient. Sustainable. On demand.**  
Companies need innovative packaging and automation solutions that can deliver increased productivity and improved sustainability. Pak On Demand™ Pouch System produces custom, sustainable fiber-based pouches on demand and seals the package for shipment - all with a single operator.  
The result is a protective package that is completely curbside-recyclable. Pak On Demand's enhanced process not only reduces labor cost, it also eliminates unnecessary void fill and increases packing rates up to five times over manual operations.

**Innovative New Fanfold - KD-fold™**  
KD-fold is a proprietary tube-shaped single-face corrugated fanfold that comes in both light weight and heavy weight options to suit different product protection requirements. These two paper-based based options are designed to combine the Pak On Demand system to efficiently produce an optimized pouch. KD-fold comes delivered on compact pallets that are easy to store and handle and can be printed with one color ink in a continuous repeat pattern.

[westrock.com/PakOnDemand](http://westrock.com/PakOnDemand)

### Pak On Demand™ Pouch System



- Sustainable fiber-based packaging
- Superior product protection
- Tear strip for easy openings and returns
- 100% curbside recyclable

**A Protective Fiber-Based Alternative to Plastic Bubble Mailers.**

<p><b>Plastic bubble mailers</b></p> <ul style="list-style-type: none"> <li>• Plastic material</li> <li>• Generally not curbside-recyclable</li> <li>• Standard sizes</li> <li>• Various sized inventory required</li> </ul>	<p><b>VS</b></p>	<p><b>Pak On Demand pouches</b></p> <ul style="list-style-type: none"> <li>• Made from sustainable fiber-based materials</li> <li>• 100% curbside-recyclable</li> <li>• Customizable</li> <li>• On-demand</li> </ul>
--	------------------	--



**WestRock** For more information, contact WestRock Automation, 4354 Southwest 34th St., Orlando, FL 32811  
Phone: 407.843.1300 • Fax: 407.843.8419 • E-mail: [info@pakedemand.com](mailto:info@pakedemand.com)

Pak On Demand™ Pouch System Sell Sheet 5 Downloads

# COLLATERAL DOWNLOADS

## DETAILS

WestRock
META<sup>®</sup> SYSTEMS

### Meta<sup>®</sup> Duo

#### In-House Channel Flexibility

- Improved speed to market
- Broad package flexibility
- Small footprint

**One machine. Multiple solutions.**

Streamline your operations and get to market quicker with Meta<sup>®</sup> Duo. WestRock's newest automation technology offers high rate multi-channel in-house automation. Meta Duo efficiently replaces overhead & closed, 8-sided, HSD, one- and two-piece SSP designs and SDCs helping you meet various retailer and label requirements from a single, small footprint machine.

Meta Duo utilizes our unique Meta<sup>®</sup> Systems precision forming technology. Cans are formed around a feed machine, ensuring close base and maximizing structural integrity, resulting in cases that outperform composite standard cases (SSCs) in product efficiency/higher run speed and stacking strength.

**Benefits of Bringing SRP Capabilities In-House**

- Eliminates need for SRP or on-packaging packaging machinery
- Weight responsibility
- Minimizes labor and handling
- Decreases product loss
- Optimized package design
- Improved speed to market

**Mandrel-Formed 2-Piece SRP Outperforms Perforated RSC**

<p><b>Competitor's Perforated RSC</b></p> <ul style="list-style-type: none"> <li>• Remnants from edges</li> <li>• Flexible design to packaging and branding</li> <li>• Strength loss due to perforation</li> </ul>	VS	<p><b>WestRock's Meta<sup>®</sup> CD</b></p> <ul style="list-style-type: none"> <li>• Clean edges - no remnants of perforated edges</li> <li>• No tools needed - no product damage</li> <li>• Easy opening and shelf stacking</li> <li>• Higher stacking strength</li> <li>• 10-20% higher compression than perforated RSC</li> <li>• Efficient structure reduces material weight</li> </ul>
--	----	--

WestRock
For more information, contact WestRock Automation: 4354 Southwest 34th St., Orlando, FL 32811  
Phone: 407.843.1300 • Fax: 407.843.3419 • E-mail: [sg@westrock.com](mailto:sg@westrock.com)

Meta<sup>®</sup> Duo Sell Sheet

4 Downloads

WestRock

### CanCollar<sup>®</sup> Fortuna<sup>™</sup>

#### Fast. Flexible. Fortuna.

**CanCollar<sup>®</sup> Fortuna<sup>™</sup> with divider**

**WestRock CanCollar<sup>®</sup> Fortuna<sup>™</sup> is a high speed automation solution for applying CanCollar and a range of other minimalist, glue-free paperboard multipack designs for standard, sleek and slim cans.**

- Fortuna can match pace with lines up to 2,000 cans per minute!
- Modular machine design offers flexibility for multiple glue-free designs on the same platform while offering future proofing capability.
- Automatic, servo-driven adjustments and common change parts enable quick and fully repeatable changeovers.

WestRock
For more information, contact WestRock Packaging Systems Customer Service: 36130 Delta France • Phone: +33 2 54 25 18 00

CanCollar<sup>®</sup> Fortuna<sup>™</sup> Sell Sheet

4 Downloads

WestRock

### CanCollar<sup>®</sup> Fortuna<sup>™</sup>

Compact machine fits into existing line layouts even when replacing small plastic ring or shrink film machines.

**Features**

- Glue-Free solution
- Modular machine design
- Servo control system
- Multi-diameter and multi-height capability

**Primary Container**

- Standard, sleek and slim cans
- Height between 110mm & 150mm
- Diameter between 53mm & 65mm
- Volume: 200ml/7.0oz through 500ml/17.0oz

**Package Formats**

- 2x2, 2x3, 2x4

**Package Styles**

**Options**

- Modules to enable CanCollar<sup>®</sup> Shield and PrePack<sup>®</sup> Pure designs
- Can orientation
- Integrated tertiary packaging module
- Integrated rotator/divider or divider modules
- Inspection systems for missing cans and mis-clipped or mislabeled cartons

Note: All dimensions and specifications subject to change without notice and depending on options or application and hardware.

WestRock
For more information, contact WestRock Packaging Systems Customer Service: 36130 Delta France • Phone: +33 2 54 25 18 00





CanCollar<sup>®</sup> Fortuna<sup>™</sup> Sell Sheet

4 Downloads

# CHATS

**Chat with Us**

1000 Abernathy Road NE Atlanta, GA 30328  
USA  
[www.westrock.com/automation](http://www.westrock.com/automation) Phone: (407) 843-1300

   



**Danny Griffith** Available  
Sr. Director of Sales

[Chat](#)

Danny has been with Westrock Automated Packaging Systems for 13 years. He has extensive knowledge of packaging materials, machines and line automation. He leads the APS sales team in the U.S. and abroad.







**Brian Thompson** Available  
Sales Manager

[Chat](#)

Brian has extensive experience in primary and secondary packaging equipment. He leads a team of packaging automation sales experts who help develop & deliver value-added solutions to our customers. His territory covers the Eastern U.S. and Eastern Canada.







**Craig Buscema** Available  
Director, Business Development

[Chat](#)

With over 25 years of industry experience, Craig specializes in developing innovative packaging design to automation solutions to help customers solve their critical packaging challenges.







**Jeff James** Available  
Director, Design Services

[Chat](#)

Jeff has extensive experience in SRP, e-commerce and fiber optimization. His structural design team—specializing in design to automation—is focused on understanding and solving customer packaging challenges. Jeff has been with WestRock for 28 years.







**Geoffroy Bretzner** Available  
Technical Sales Director

[Chat](#)

Geoff oversees technical sales globally for paperboard multi-packing machines including sales, applications, contracts, agreements and machine execution. He has 15 years' experience working in end-of-line packaging solutions and complete line design.





**Brad Walling** Available  
Sr. Director, Design

[Chat](#)

Brad leads our world class Design team focused on addressing sustainable paper-based packaging solutions in the Food and Beverage Americas market. We take a partnered approach to ensure that your packaging fits your needs now and in the future!



12

CHATS INITIATED



# PERSONALIZED REGISTRATION PAGE

The screenshot shows a registration page for PACK EXPO Connects 2020. At the top, there is a banner with the PACK EXPO logo, the text 'CONNECTS' with arrows, the dates 'November 9-13, 2020', and the slogan 'LIVE. VIRTUAL. REIMAGINED.' in large, bold letters. To the right of the banner is a 'Produced by' logo for 'PIMME MEDIA GROUP'. Below the banner, the text reads 'Join WestRock at PACK EXPO Connects 2020' and 'Visit our virtual showroom for solutions to your biggest challenges.' There is an orange button labeled 'REGISTER FOR FREE NOW'. Below this is a box containing the WestRock logo and the text 'WestRock invites you to Connect in November'. A smaller paragraph of text describes the event as a brand new live, web-based event with live chats, product and machinery demos, and educational opportunities. At the bottom of this box is another orange button labeled 'VISIT OUR SHOWROOM'.

43

REGISTRATIONS

# LEADS

- LEAD DETAILS
- ROI HISTORY

# LEAD DETAILS

## VIRTUAL SHOWROOM

405

### North American

40 Canada  
11 Mexico  
354 United States

68

### International

1	Argentina	4	France	3	Poland
7	Australia	5	Germany	1	Romania
1	Belgium	3	India	3	Spain
2	Brazil	3	Italy	1	Swaziland
3	Chile	1	Jamaica	1	Sweden
1	China	4	Japan	3	Switzerland
3	Columbia	1	Korea	1	Trinidad and Tobago
1	Ecuador	3	Netherlands	1	Turkey
1	Egypt	1	New Zealand	7	United Kingdom
1	Estonia	1	Panama		

Refer to Slide 3

# LEAD DETAILS

## ADVERTISING ACTIVITIES

Trade Publications	Leads
<i>Canadian Packaging</i>	66
<i>Prepared Foods MUST SEE</i>	10
<i>Packaging World Video Spotlight</i>	98

Show Specific Opportunities	Leads
SPOTLIGHT ON PACK EXPO Connects	39
PACK EXPO Connects Exhibitor Previews	152

Leads from advertising activities were cross-referenced with leads from our Virtual Showroom. There were eight duplicates bringing the total number of ad leads to 387. Advertising leads are detailed on Slides 33-39.

# ROI HISTORY

Show	Year	Leads			Equipment Sales	Expected Corrugated Pull	ROI*
		Badge Scans	Other Sources	Total			
PEC Connects	2020	473**	387	860	-	-	TBD
PACK EXPO Las Vegas	2019	366	~1567	~1933	██████████	██████████	\$256.14 to \$1
PACK EXPO International	2018***	581	318	899	██████████	██████████	\$102.57 to \$1
PACK EXPO Las Vegas	2017	607	50	657	██████████	██████████	\$233.65 to \$1
PACK EXPO International	2016	554	25	579	██████████	██████████	\$133.02 to \$1
PACK EXPO Las Vegas	2015	433	36	469	██████████	██████████	\$195.25 to \$1
PACK EXPO International	2014	487	122	609	██████████	██████████	\$84.68 to \$1

\*ROI = Equipment Sales + Expected Corrugated Pull ÷ Show Costs (per \$ spent)

\*\*Virtual Showroom Activity

\*\*\*Combined WRK and BOD

# MARKETING & PROMOTION

- PRINT ADVERTISING
- WEB ADVERTISING
- E-BLASTS
- CUSTOMER INVITE PROGRAM
- SOCIAL MEDIA

# PRINT ADVERTISING

## TRADE PUBLICATIONS



*Packaging World* – Front Covers, October & November 2020

# PRINT ADVERTISING

## TRADE PUB AD CAMPAIGN



Visit our virtual showroom  
page 158 at PACK EXPO Connects  
November 9-11, 2020

**IMPROVE EFFICIENCY  
WITH INTEGRATED  
END-OF-LINE SOLUTIONS.**

Introducing the CP eMerge™ Combo, WestRock's newest automation technology for food bowls that combines sustainable secondary and tertiary packaging into one system. The single operator, end-of-line solution manages multiple SKUs and various demands by allowing for quick changeover between a range of bowls and trays. The integrated combo design is uniquely suitable for those with footprint constraints.

**Complexity, simplified.**



[westrock.com/automation](http://westrock.com/automation)



CP eMerge™ Combo



Visit our virtual showroom  
page 158 at PACK EXPO Connects  
November 9-11, 2020

**INCREASE FLEXIBILITY  
WITH AUTOMATED  
SHELF-READY PACKAGING.**

WestRock's Meta® Duo offers a true multi-channel, in-line automation of one- and two-piece shelf-ready packaging designs and strips in-own-container units. Utilizing our unique Meta® System precision forming technology, Meta Duo efficiently transitions between 4-sided, 6-sided and full-dished containers, helping you meet various retailer and e-tailer requirements from a single, small footprint machine.

**Multiple channels. One solution.**



[westrock.com/metaduo](http://westrock.com/metaduo)



Meta® Duo



Visit our virtual showroom  
page 158 at PACK EXPO Connects  
November 9-11, 2020

**STREAMLINE YOUR  
E-COMMERCE PROCESSES  
WITH INTELLIGENT TECHNOLOGY.**

WestRock's BoxSizer® intelligent right-sizing technology is the only machine on the market that can right-size multiple pre-filled box flaps into a single or multiple flaps without the need for changeovers. By ensuring optimal package size and eliminating void fill, this solution reduces labor, improves sustainability, and lowers your total cost.

**Package variability. Solved.**



[westrock.com/boxsizer](http://westrock.com/boxsizer)



BoxSizer® Right-Sizing Technology



Visit our virtual showroom  
page 158 at PACK EXPO Connects  
November 9-11, 2020

**REDUCE LABOR COST  
WITH RIGHT-SIZED AUTOMATION.**

WestRock's Pak On Demand™ Pouch System 3D scans products on a conveyor, creates a custom, right-sized, curbside-recyclable pouch on demand and seals the package for shipment—all with a single operator. The streamlined process not only reduces labor cost, it also eliminates unnecessary void fill and shipping charges, and increases packing rates up to five times over manual operators.

**Right sized. Right now.**



[westrock.com/pakondemand](http://westrock.com/pakondemand)



Pak On Demand™ Pouch System

Trade Publications:

**Canadian Packaging | DC Velocity | Emballages Les Nouvelles | Food Processing  
Packaging Strategies | Packaging World | Prepared Foods**



# PRINT ADVERTISING

## TRADE PUB AD SCHEDULE

### CP EMERGE™ COMBO

#### *Canadian Packaging*

- September – Pg.7
- October Pre-Show Issue – IFC\*
- November – Pg.2

#### *Emballages Les Nouvelles*

- September – Pg.13

#### *Food Processing*

- October – IBC\*\*
- November – IBC\*\*

#### *Packaging Strategies*

- October – Pg.7
- November – Pg.9

#### *Packaging World*

- September – Pg.13
- October Show Issue – IBC\*\*
- November – Pg.5

#### *Prepared Foods*

- October – Pg.3
- November – Pg.3

### META® DUO

#### *Canadian Packaging*

- September – Pg.19
- October – Pg.25
- November – Pg.21

#### *Packaging Strategies*

- October – Pg.9

#### *Packaging World*

- September – Pg.19
- October Show Issue – Pg.17
- November – Pg.9

### BOXSIZER® RIGHT-SIZING TECHNOLOGY

#### *Canadian Packaging*

- September – Pg.32
- October – Pg.38
- November – Pg.32

#### *Packaging Strategies*

- October – Pg.11
- November – Pg.7

#### *Packaging World*

- September – Pg.15
- October Show Issue – Pg.13
- November – Pg.11

### PAK ON DEMAND™ POUCH SYSTEM

#### *Canadian Packaging*

- September – Pg.35
- October – Pg.63
- November – Pg.45

#### *DC Velocity*

- October

#### *Packaging Strategies*

- October – Pg.13

#### *Packaging World*

- September – Pg.17
- October Show Issue – Pg.15
- November – Pg.13

\*IFC – Inside Front Cover | \*\*IBC – Inside Back Cover

# PRINT ADVERTISING

## SHOW PUBLICATIONS

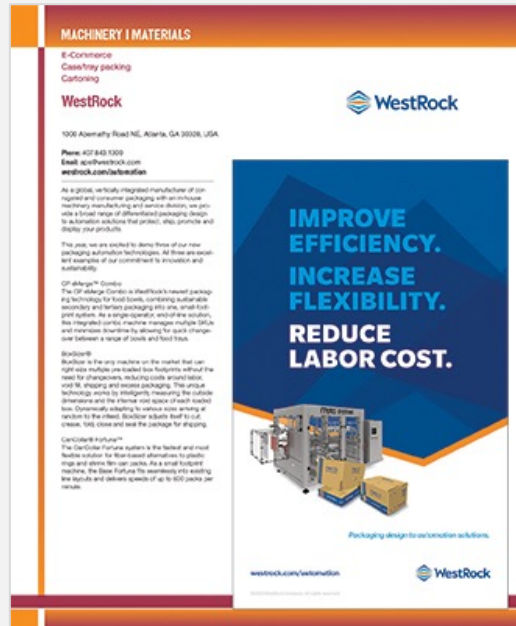

Company Profile Pg. 181



CP eMerge™ Combo Pg.13

PMMI Media Group – PACK EXPO Connects *Showcase* October 2020

# PRINT ADVERTISING

## SHOW PUBLICATIONS



Visit our virtual showrooms  
on show 158 at PACK EXPO Connects  
November 9-11, 2020

### INCREASE FLEXIBILITY WITH AUTOMATED SHELF-READY PACKAGING.

WestRock's Meta® Duo offers true multi-channel, in-house automation of one- and two-piece shelf-ready packaging designs and ship-to-own container units. Using our unique Meta® System precision-forming technology, Meta Duo efficiently transitions between 4-sided, 3-sided and 2-sided containers, helping you meet various retailer and e-tailer requirements from a single, small footprint machine.

**Multiple channels. One solution.**



[westrock.com/metaduo](http://westrock.com/metaduo)

 WestRock

©2020 WestRock Company. All rights reserved.

Meta® Duo

Pg.15



Visit our virtual showrooms  
on show 158 at PACK EXPO Connects  
November 9-11, 2020

### STREAMLINE YOUR E-COMMERCE PROCESSES WITH INTELLIGENT TECHNOLOGY.

WestRock's BoxSizer® intelligent right-sizing technology is the only machine on the market that can right-size multiple preboxed box footprints arriving at random to the fitted without the need for changeovers. By ensuring optimal package size and eliminating void fill, this solution reduces labor, improves sustainability, and lowers your total cost.

**Package variability. Solved.**



[westrock.com/boxsizer](http://westrock.com/boxsizer)

 WestRock

©2020 WestRock Company. All rights reserved.

BoxSizer®

Pg.17



Visit our virtual showrooms  
on show 158 at PACK EXPO Connects  
November 9-11, 2020

### REDUCE LABOR COST WITH RIGHT-SIZED AUTOMATION.

WestRock's Pak On Demand™ Pouch System 3D scans products on a conveyor, creates a custom, right-sized, outside-recyclable pouch on demand and seals the package for shipment—all with a single operator. The streamlined process not only reduces labor cost, it also eliminates unnecessary void fill and shipping charges, and increases packing rates up to five times over manual operations.

**Right sized. Right now.**



[westrock.com/pakondemand](http://westrock.com/pakondemand)

 WestRock

©2020 WestRock Company. All rights reserved.

Pak On Demand™  
Pouch System

Pg.19

PMMI Media Group – PACK EXPO Connects *Showcase* October 2020

# PRINT & DIGITAL ADVERTISING

## SHOW PUBLICATIONS



Visit our virtual showroom  
[pe.show/158](#) at PACK EXPO Connects  
November 9-13, 2020



### IMPROVE EFFICIENCY WITH INTEGRATED END-OF-LINE SOLUTIONS.

Introducing the CP eMerge™ Combo, WestRock's newest automation technology for food boxes that combines sustainable secondary and tertiary packaging into one system. The single-operator, end-of-line solution manages multiple SKUs and minimizes downtime by allowing for quick changeover between a range of levels and trays. The ring and comb designs are uniquely suitable for those with footprint constraints.

**Complexity, simplified.**



[westrock.com/automation](#)

©2020 WestRock Company. All rights reserved.



CP eMerge™ Combo Back Cover

Visit our virtual showroom  
[pe.show/158](#) at PACK EXPO Connects  
November 9-13, 2020



### INCREASE FLEXIBILITY WITH AUTOMATED SHELF-READY PACKAGING.

WestRock's Meta® Duo offers true multi-channel, in-house automation of one- and two-piece shelf-ready packaging designs and single-in-line container units, using our unique Meta® System precision-forming technology. Meta Duo efficiently transitions between 4-sided, 3-sided and full-attached containers, helping you meet various retailer and e-tailer requirements from a single, small footprint machine.

**Multiple channels. One solution.**



[westrock.com/metaduo](#)

©2020 WestRock Company. All rights reserved.



Meta® Duo Pg.115

Visit our virtual showroom  
[pe.show/158](#) at PACK EXPO Connects  
November 9-13, 2020



### STREAMLINE YOUR E-COMMERCE PROCESSES WITH INTELLIGENT TECHNOLOGY.

WestRock's BoxSizer® intelligent right-sizing technology is the only machine on the market that can right-size multiple pre-stacked box footprints arriving at random to the feed without the need for changeovers. By ensuring optimal package size and eliminating void fill, this solution reduces SKUs, improves sustainability, and lowers your total cost.

**Package variability. Solved.**



[westrock.com/boxsizer](#)

©2020 WestRock Company. All rights reserved.



BoxSizer® Pg.159

PMMI Media Group – PACK EXPO Connects *Virtual Event Guide / Live Demo Planner* October 2020

# PRINT & DIGITAL ADVERTISING

## SHOW PUBLICATIONS

36

**PACK EXPO**

**CONNECTS**

November 9-13, 2020

**LIVE DEMO PLANNER**

Get ready for the preeminent global virtual event for packagers! PACK EXPO Connects features 2,600 live product demos from leading suppliers. Highlighted within are just some of the demos taking place.\* Be sure you and your team view the full demo line-up and create your plan for the event today.

Register and create your plan at [packexpoconnects.com](http://packexpoconnects.com)

\*This guide features a selection of participating exhibitors with scheduled demos as of press time. View the full live demo lineup online at [packexpoconnects.com](http://packexpoconnects.com).

Filling, Capping & Sealing Rigid Containers or Trays	P.37
Bagging, Pouching & Wrapping	P.40
Cartoning & Multipacking	P.44
Coding, Marking, Labeling & Printing	P.46
End-of-Line Equipment	P.50
Feeding, Conveying, Accumulating & Product Handling	P.56
X-ray, Vision, Inspection, Testing & Weighing	P.59
Containers, Materials & Transport Packaging	P.61
Controls, Software & Machine Components	P.62
Plant Facilities & Infrastructure	P.64
Food Processing Equipment	P.65
Life Sciences	P.67
Sustainability	P.70
E-Commerce	P.71

122 **PACK EXPO Connects LIVE DEMO PLANNER**

**End-of-Line Equipment**

Take it to the floor to view demos from a mobile device!

**Featured Demos**

<b>Petpack Inc.</b>   Processed Snack Wrapping & Case Packing: Optimization of the wide array of product/collection modules designed to meet the packaging requirements of all industries.	PE show/141
<b>Parmer Tech</b>   Customizable Robotic Case Packing: It all starts with your specs. Discover how our team can bring your vision to life and guide you from your idea to your first ever savings in usable case packs.	PE show/152
<b>Parmer Tech</b>   DeepFreezing: A guide to efficiently deep-fry or hot-bag. Learn how a flexible and mobile 3D Vision depth sensor can help you reduce labor costs in an automated facility.	PE show/152
<b>Quant Industrial, LLC</b>   How 4th Gen Product View in 2021: ADA 4000+ Lab: Learn how Quant's Intelligent Autonomous Service Complexes with 4th Gen's and how it can regulate into production to support our users.	PE show/150
<b>Quant Industrial, LLC</b>   Packaging Simplified: Modular Engineering & Flexible design: Learn about the Rapid Roll Robotic Feeder with GPCX deepdrinking and case software, used in the market leading and optimized configurations.	PE show/150
<b>Quant Industrial, LLC</b>   Robotic Top Load Case Packing Simplified: Learn how Quant's Gux Pick Robotic Case Packer with GPCX deepdrinking and case software can solve your packaging automation needs.	PE show/150
<b>Quant Industrial, LLC</b>   Setting Robotic System Interfaces to the Next Level: GPCX, GPCX and GRL deepdrinking and case software creates seamless automation interfaces for filling, Case Packing, and Palletting.	PE show/150
<b>Robotech USA Inc.</b>   Live and virtual control of plant processes: Learn how to benefit from the Robotech Control System, an integrated software platform for system monitoring, process and quality control.	PE show/139
<b>Schulz North America LLC</b>   A preconfigured case packer: Translatability ready for use: A compact case packer designed for specific product and packaging formats of an American manufacturer.	PE show/142
<b>Sigma Packaging Solutions</b>   Case Packer: The work horse of end-of-line equipment! Our case-friendly and versatile bottom case packer now you control from top to side to bottom loading.	PE show/134
<b>Sigma Packaging Solutions</b>   Case Integration: Putting the pieces together for seamless operation! Let us show you the Sigma approach to integration from the tools to the machines and everything in between.	PE show/134
<b>Sitel Inc.</b>   Increase your production efficiency and work safely with robotic solutions: Replace strenuous manual palletizing and/or distribution speed time and reduce CO2 production costs with compact side and rear-frame robotic palletizing solutions.	PE show/131
<b>Sigmate</b>   Battery Back for Plastic Shrinkage - Market-leading technology: Innovative and intuitive SRT3 hand tools offer a range of operation modes and can help reduce errors and increase load stability.	PE show/154
<b>Sigmate</b>   Industrial Automation - Solutions to Increase Efficiency: Learn how and how to enhance automation can improve efficiency, manage costs and increase throughput of equipment.	PE show/154
<b>Sigmate</b>   SEM   Sigmate Demand Palletizer (DSP) Shipping Equipment Line: The DSP line from start-up to fully automatic, uses proven technology with reliable operation and flexible configurations.	PE show/154
<b>Synch International</b>   Optimize Packaging Operations: Streamline Compliance, Reduce Your Risk! See how the right code on the right package delivers real-time, accurate product data and connectivity across the supply chain.	PE show/130
<b>Synch International</b>   Use that Packaging to Establish Connectivity: Join the Supply Chain. A line of work of Packaging Intelligence & Smart Production solutions that meet product, customer, and a connected, smart packaging ecosystem.	PE show/130
<b>The Far Packaging Group</b>   Lower Level Infeed Layer Counting: Robustness - Much as engineering of common features and frame systems ensure quality control and complete flexibility, the #1 selling line of palletizers in North America.	PE show/126
<b>The Far Packaging Group</b>   Lower Level Infeed Robotic Palletizer: Modular engineering of common features and frame systems ensure quality control and complete flexibility, the #1 selling line of palletizers in North America.	PE show/126
<b>The Far Packaging Group</b>   Lower Level Infeed Robotic Palletizer: Modular engineering of common features and frame systems ensure quality control and complete flexibility, the #1 selling line of palletizers in North America.	PE show/126
<b>WestRock</b>   Increase efficiency & material use with integrated packaging solutions. Introducing CP all-in-one™: Combines our newest technology for front board that combines sustainable secondary & tertiary packaging in one solution.	PE show/158
<b>WestRock</b>   Looking for fiber alternatives to plastic case and bottle packs? Introducing ConCoRe® Fiber™ - the latest and most versatile solution of its kind for case and bottle multipacks.	PE show/158

Don't miss out! Attendance is free. Add demos to your event plan at [packexpoconnects.com](http://packexpoconnects.com)

158 **PACK EXPO Connects LIVE DEMO PLANNER**

**E-Commerce**

Take it to the floor to view demos from a mobile device!

**Featured Demos**

<b>Antares Vision North America</b>   Boosting Consumer Engagement with Product Digital Identifiers: Pivotal consumer engagement, customer insight, brand equity and marketing experiences with product digitization.	PE show/248
<b>Antares Vision North America</b>   Streamline Tracking & Transportation through Supply Chain Digitalization: Fully integrated Digital Supply Chain with transparent capabilities in no longer just an option with today's business model.	PE show/248
<b>AMCIC Machine Creators</b>   Leading Edge Order Fulfillment Software: AMCIC is the leader in robotic applications for case, channel fulfillment. Let us guide you to the solutions that work for the ROI you need.	PE show/161
<b>Relis USA Incorporated</b>   Making Eco-smart Packaging Sustainable by Eliminating Void Fill: Learn how advanced technology can improve your eco-smart packaging and eliminate void fill while the packing benefits of pillow air.	PE show/136
<b>Proco System USA, Inc.</b>   Making the Switch from Rigid to Flexible Packaging for FFD Containers, Wine and Spirits: Learn how to stand out from the rest of your and open new market doors with cool and smart and sustainable fully flexible packaging.	PE show/134
<b>R.E. Fuller Company</b>   R.E. Fuller Case Seamer™ Edge & R.E. Fuller Case Seamer™ Edge is an innovative double-sided closing case that uses our patented edge closing technology to make eco-smart cases easier.	PE show/130
<b>International Paper</b>   Intelligent Packaging, Sealing and e-Commerce Ready Packaging: Let us show you how International Paper designs eco-smart ready packages that hold up in the most challenging supply chain.	PE show/207
<b>ProPacker</b>   Eco-smart Case with Flexible Packaging: Moving to flexible packaging enables e-commerce and sustainability.	PE show/227
<b>Sigmate</b>   Optimizing E-Commerce Packaging Efficiency: Maximize a product size index that packaging is challenge for e-commerce businesses even when actual packing can exceed the index.	PE show/156
<b>WestRock</b>   Elevate your e-commerce packaging with intelligent technology: BoxSizer™, the only machine on the market that can right-size multiple palletized box outputs without the need for changeovers.	PE show/136

Don't miss out! Attendance is free. Add demos to your event plan at [packexpoconnects.com](http://packexpoconnects.com)

PMMI Media Group – PACK EXPO Connects *Virtual Event Guide / Live Demo Planner* October 2020

Categories:





End-of-Line Equipment (CP eMerge™ Combo & CanCollar® Fortuna™) | E-commerce (BoxSizer®)





# PRINT & DIGITAL ADVERTISING

## SHOW PUBLICATIONS

**PACK EXPO Connects GAME PLAN 35**

**Cartoning & Multipacking**

**TRIANGLE**  



  
 View demo times & more of PE.show/140  
**Change Carton Sizes in 3 Minutes**  
 The T-1000 is the ultimate, repeatable pack buffer changer with our Changeover Wizard. Easy to operate.  
**Ready to Improve Efficiency?**  
 Drive productivity up 20% and energy 20% lower with our new T-1000. It's the only machine that can handle up to 100 cartons per hour.  
**Save Time, Cartoner for Top Loading**  
 Look for our new T-1000. It's the only machine that can handle up to 100 cartons per hour. It's the only machine that can handle up to 100 cartons per hour.

**WestRock**  



  
 View demo times & more of PE.show/158  
**IP always™ Guide**  
 Our latest technology for food levels, conditions, variable secondary and tertiary packaging in one system.  
**ReelPack**  
 The only machine on the market that can handle multiple applications without changeovers.  
**CardiPack® Partner™**  
 Our best-in-class solution for plastic and flexible packaging in one system.

**PACK EXPO Connects GAME PLAN 86**

**E-Commerce**

**FANUC**  



  
 View demo times & more of PE.show/515  
**Next Generation Fulfillment**  
 The new 5000i is the only robot that can handle up to 100 cartons per hour. It's the only robot that can handle up to 100 cartons per hour.  
**Drive Channel Fulfillment**  
 Drive Channel Fulfillment is the only robot that can handle up to 100 cartons per hour. It's the only robot that can handle up to 100 cartons per hour.  
**Water Improves Speed and Accuracy**  
 Water improves speed and accuracy. It's the only robot that can handle up to 100 cartons per hour. It's the only robot that can handle up to 100 cartons per hour.

**FELINS**  



  
 View demo times & more of PE.show/586  
**Ultimate Reel/Trapping Machine**  
 Use ultimate technology to handle and wrap products with flexible bags. It's the only machine that can handle up to 100 cartons per hour.  
**ReelPack® for Truck & Train**  
 Label and cartons in one system. It's the only machine that can handle up to 100 cartons per hour.  
**Automatic Pallet Reader**  
 Increase productivity and reduce error. It's the only machine that can handle up to 100 cartons per hour.

**SIGNODE**  



  
 View demo times & more of PE.show/256  
**SRM 4100 3-Cube Feeder**  
 It's the only machine for food & consumer. It's the only machine that can handle up to 100 cartons per hour.  
**Multi-Pack 300-MAP®**  
 It's the only machine for food & consumer. It's the only machine that can handle up to 100 cartons per hour.  
**Reel-Pack Container**  
 Reel-Pack Container is the only machine that can handle up to 100 cartons per hour.





**WestRock**  











  
 View demo times & more of PE.show/158  
**ReelPack**  
 The only machine on the market that can handle multiple applications without changeovers.  
**PAK On Demand™ Pouch System**  
 PAK On Demand™ Pouch System is the only machine that can handle up to 100 cartons per hour.  
**Box On Demand**  
 Box On Demand is the only machine that can handle up to 100 cartons per hour.





**PACK EXPO Connects GAME PLAN 50**

**End-of-Line Equipment**

**Techniplex**  



  
 View demo times & more of PE.show/596  
**RUNNER 4 HIGH-LEVEL PALLETIZER**  
 The only machine that can handle up to 100 cartons per hour. It's the only machine that can handle up to 100 cartons per hour.  
**RUNNER 4 LOW-LEVEL PALLETIZER**  
 The only machine that can handle up to 100 cartons per hour. It's the only machine that can handle up to 100 cartons per hour.  
**WINTOX KIBOTIC PALLETIZER**  
 The only machine that can handle up to 100 cartons per hour. It's the only machine that can handle up to 100 cartons per hour.

**TOPTIER**  



  
 View demo times & more of PE.show/258  
**Low Infeed Layer Palletizer**  
 The only machine that can handle up to 100 cartons per hour. It's the only machine that can handle up to 100 cartons per hour.  
**High Infeed Layer Palletizer**  
 The only machine that can handle up to 100 cartons per hour. It's the only machine that can handle up to 100 cartons per hour.  
**Low Infeed Robotic Palletizer**  
 The only machine that can handle up to 100 cartons per hour. It's the only machine that can handle up to 100 cartons per hour.

**WestRock**  



  
 View demo times & more of PE.show/158  
**IP always™ Guide**  
 Our latest technology for food levels, conditions, variable secondary and tertiary packaging in one system.  
**ReelPack**  
 The only machine on the market that can handle multiple applications without changeovers.  
**ReelPack**  
 The only machine on the market that can handle multiple applications without changeovers.

**WEXXAR BEL DEKKA**  



  
 View demo times & more of PE.show/116  
**Easy Load Case Former**  
 The only machine that can handle up to 100 cartons per hour. It's the only machine that can handle up to 100 cartons per hour.  
**Easy Load Case Former**  
 The only machine that can handle up to 100 cartons per hour. It's the only machine that can handle up to 100 cartons per hour.  
**Low Maintenance Tray Former**  
 The only machine that can handle up to 100 cartons per hour. It's the only machine that can handle up to 100 cartons per hour.

PMMI Media Group – PACK EXPO Connects *Game Plan* October 2020

Categories:

Cartoning & Multipacking | E-commerce | End-of-Line Equipment

# PRINT & DIGITAL ADVERTISING

## SHOW PUBLICATIONS

**Cartoning & Multipacking** 1

**WestRock**  
Years in business: 47+ • Employees: 50,000+

Type in the URL below to view product [INFO](#), [VIDEOS](#) or [DEMOS](#) from this featured PACK EXPO Connects exhibitor.

**Improve Efficiency with Integrated End-of-Line Solutions CP eMerge™ Combo**  
CP eMerge™ Combo, WestRock's newest automation technology for food bowls that combines sustainable secondary and tertiary packaging into one system. The single operator, end-of-line solution manages multiple SKUs and minimizes downtime by allowing for quick changeover between a range of bowl and tray. The integrated combo design is uniquely suitable for those with footprint constraints.  
[▶▶▶▶▶ pe.show/sample/6575264](#)

**Streamline Your E-commerce Packaging Processes BackSizer®**  
BackSizer® is the only machine on the market that can right-size multiple preboxed box footprints, allowing you to fit the product without the need for changeovers. By ensuring optimal package size and eliminating void fill, this solution reduces labor, improves sustainability, and lowers your total cost.  
[▶▶▶▶▶ pe.show/sample/605484](#)

**Looking for Fiber Alternatives to Plastic Multipacks? CanCollar® Fortana™**  
CanCollar® Fortana™ is a high-speed automation solution for applying CanCollar and straps of other materials, glue-free paperboard multipack designs. This solution minimizes your time on developing flexible, fiber-based solutions that help our customers address their sustainable packaging goals while managing the cost and risk of this transformation.  
[▶▶▶▶▶ pe.show/sample/9205509](#)

As a global, vertically integrated manufacturer of corrugated and consumer packaging with an in-house machinery manufacturing and service division, WestRock provides a broad range of differentiated packaging design to automation solutions that protect, ship, promote and display your products.

Atlanta, GA • (407) 843-1300

Effortlessly, thanks for engaging with us at PACK EXPO Connects 2020. One of our packaging representatives will be reaching out soon. Contact us at [api@westrock.com](mailto:api@westrock.com). [▶▶ CONNECTS C](#)

**E-commerce** 1

**WestRock**  
Years in business: 47+ • Employees: 50,000+

Type in the URL below to view product [INFO](#), [VIDEOS](#) or [DEMOS](#) from this featured PACK EXPO Connects exhibitor.

**Streamline Your E-commerce Packaging Processes BackSizer®**  
BackSizer® is the only machine on the market that can right-size multiple preboxed box footprints, allowing you to fit the product without the need for changeovers. By ensuring optimal package size and eliminating void fill, this solution reduces labor, improves sustainability, and lowers your total cost.  
[▶▶▶▶▶ pe.show/sample/6634423](#)

**Increase Productivity with Fiber-Based Pouch System Pak On Demand™ Pouch System**  
An automated and sustainable fiber-based alternative to non-recyclable plastic strapping, Pak On Demand™ Pouch System contains a custom, carbon dioxide recyclable pouch on demand and seals the package for shipment—all with single operator. The integrated process not only reduces labor cost, it also eliminates unnecessary void fill and shipping charges and increases packing rates up to five times over manual operations.  
[▶▶▶▶▶ pe.show/sample/4463220](#)

**Make Your Operation More Efficient with Custom-Fit Boxes Box On Demand®**  
Box On Demand® gives you the ability to make right-sized boxes for every order on-site and on-demand. Reduce packaging costs and make your operation more efficient with custom-fit boxes that optimize your packaging, reduce box inventory and minimize shipping damage by providing better product protection.  
[▶▶▶▶▶ pe.show/sample/9745893](#)

As a global, vertically integrated manufacturer of corrugated and consumer packaging with an in-house machinery manufacturing and service division, WestRock provides a broad range of differentiated packaging design to automation solutions that protect, ship, promote and display your products.

Atlanta, GA • (407) 843-1300

Effortlessly, thanks for engaging with us at PACK EXPO Connects 2020. One of our packaging representatives will be reaching out soon. Contact us at [api@westrock.com](mailto:api@westrock.com). [▶▶ CONNECTS C](#)

**End-of-Line Equipment** 1

**WestRock**  
Years in business: 47+ • Employees: 50,000+

Type in the URL below to view product [INFO](#), [VIDEOS](#) or [DEMOS](#) from this featured PACK EXPO Connects exhibitor.

**Improve Efficiency with Integrated End-of-Line Solutions CP eMerge™ Combo**  
CP eMerge™ Combo, WestRock's newest automation technology for food bowls that combines sustainable secondary and tertiary packaging into one system. The single operator, end-of-line solution manages multiple SKUs and minimizes downtime by allowing for quick changeover between a range of bowl and tray. The integrated combo design is uniquely suitable for those with footprint constraints.  
[▶▶▶▶▶ pe.show/sample/9215995](#)

**Increase Flexibility with Automated Shelf-Ready Packaging Meta® Duo**  
Meta® Duo offers true multi-channel, in-house automation of E and Z shape shelf-ready packaging design and in-line communication units, utilizing our custom Meta® Systems precision manifold forming technology. Meta Duo offers true form, stretch, folded and multi-sided containers, helping you meet various retailer and end-user requirements from a single, small footprint machine.  
[▶▶▶▶▶ pe.show/sample/3552405](#)

**Streamline Your E-commerce Packaging Processes BackSizer®**  
BackSizer® is the only machine on the market that can right-size multiple preboxed box footprints, allowing you to fit the product without the need for changeovers. By ensuring optimal package size and eliminating void fill, this solution reduces labor, improves sustainability, and lowers your total cost.  
[▶▶▶▶▶ pe.show/sample/1805384](#)

**Looking for Fiber Alternatives to Plastic Multipacks? CanCollar® Fortana™**  
CanCollar® Fortana™ is a high-speed automation solution for applying CanCollar and straps of other materials, glue-free paperboard multipack designs. This solution minimizes your time on developing flexible, fiber-based solutions that help our customers address their sustainable packaging goals while managing the cost and risk of this transformation.  
[▶▶▶▶▶ pe.show/sample/948485](#)

As a global, vertically integrated manufacturer of corrugated and consumer packaging with an in-house machinery manufacturing and service division, WestRock provides a broad range of differentiated packaging design to automation solutions that protect, ship, promote and display your products.

Atlanta, GA • (770) 866-1000

Effortlessly, thanks for engaging with us at PACK EXPO Connects 2020. One of our packaging representatives will be reaching out soon. Contact us at [api@westrock.com](mailto:api@westrock.com). [▶▶ CONNECTS C](#)

Your next automation solution is here. [▶▶▶▶▶ pe.show/158 at PACK EXPO Connects November 9-11, 2020](#)



**IMPROVE EFFICIENCY WITH INTEGRATED END-OF-LINE SOLUTIONS.**

Introducing the CP eMerge™ Combo, WestRock's newest automation technology for food bowls that combines sustainable secondary and tertiary packaging into one system. The single operator, end-of-line solution manages multiple SKUs and minimizes downtime by allowing for quick changeover between a range of bowls and trays. The integrated combo design is uniquely suitable for those with footprint constraints.

**Complexity, simplified.**

[westrock.com/automation](http://westrock.com/automation)

[▶▶▶▶▶ pe.show/sample/948485](#)

**WestRock**

CP eMerge™ Combo Back Cover

PMMI Media Group – PACK EXPO Connects **Second Look** November 2020

Categories:  
Cartoning & Multipacking | E-commerce | End-of-Line Equipment

# SPONSORED E-NEWSLETTERS

## TRADE PUBLICATIONS

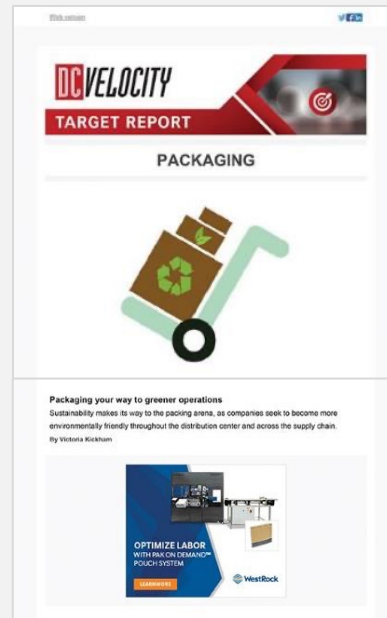

Deployment Date: 9/1/20

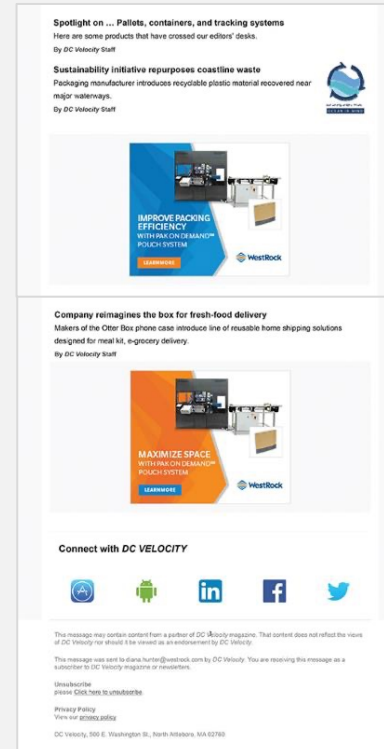

### DC Velocity – TARGET REPORT

Featured Solution:  
Pak On Demand™ Pouch System



# SPONSORED E-NEWSLETTERS

## TRADE PUBLICATIONS

10/21/2020

### PACKAGING STRATEGIES MUST VISIT

Dear Diana,

PACK EXPO Connects is less than a month away, Nov. 9-13. Are you looking for an automated, shelf-ready packaging solution? To streamline and save costs for e-commerce demand? Or to reduce labor costs with pouch right-sizing? The products below, by WestRock, will be demonstrated live in a virtual showroom during the event. See if these can add to your packaging line.



Thanks for reading,  
Kristen Kazantzi, Editor-in-Chief, [Packaging Strategies](#)

**Improve efficiency with integrated end-of-line packaging solutions.**

Introducing the CP eMerge™ Combo, our newest automation technology for food bowls that combines sustainable secondary and tertiary packaging into one system. The single-operator, end-of-line solution manages multiple SKUs and minimizes downtime by allowing for quick changeover between a range of bowls and trays. The integrated combo design is uniquely suitable for those with footprint constraints. Complexity, simplified.

See a live demo! Visit our [virtual showroom](#) at PACK EXPO Connects, November 9-13, 2020.



[Click here for more!](#)

Deployment Dates:  
9/23/20 & 10/21/21

**Increase flexibility with automated shelf-ready packaging.**

Meta Duo offers true multi-channel, in-house automation of one- and two-piece shelf-ready packaging designs and shrink-wrap-container units. Utilizing our unique Meta® Systems precision-forming technology, Meta Duo efficiently transitions between 4-sided, 6-sided and half-slotted containers, helping you meet various retailer and e-tailer requirements from a single, small footprint machine. **Multiple channels. One solution.**

Visit our [virtual showroom](#) at PACK EXPO Connects, November 9-13, 2020 to learn more.



[Click here for more!](#)

**Streamline your e-commerce packaging process with intelligent technology.**

BoxSizer® is the only machine on the market that can right size multiple preloaded box footprints arriving at random to the infeed without the need for changeovers. By ensuring optimal package size and eliminating void fill, this solution reduces labor, improves sustainability, and lowers your total cost. **Package variability. Solved.**

See a live demo of BoxSizer® Intelligent Right-Sizing Technology! Visit our [virtual showroom](#) at PACK EXPO Connects, November 9-13, 2020.



[Click here for more!](#)

**Reduce labor cost with automated right-sizing pouch system.**

Pak On Demand™ Pouch System 3D scans products on a conveyor, creates a custom, right-sized, curbside recyclable pouch on demand and seals the package for shipment – all with a single operator. The streamlined process not only reduces labor cost, it also eliminates unnecessary void fill and shipping charges and increases packing rates up to five times over manual operations. **Right sized. Right now.**

Visit our [virtual showroom](#) at PACK EXPO Connects, November 9-13, 2020 for more information.



[Click here for more!](#)

**More from Packaging Strategies**

**Top 100 Food and Beverage Packaging Companies**  
Recent trends in the Food and Beverage sector have come out of the coronavirus pandemic. [Read More](#)

**Can Your Brand Pass the "First Moment of Truth" Test?**  
How color quality plays a significant role in consumer preference. [Read More](#)

**Produce Moves to the Pantry**  
Due in part to the ongoing pandemic, consumers are choosing shelf-stable and frozen fruits and vegetables over fresh. [Read More](#)



**PACKAGING STRATEGIES WANT MORE?**

Copyright 2020 by BWP Media II, LLC. All Rights Reserved.  
#P202009  
2421 W. Big Green Rd. Suite 700  
Troy, MI 48068

To ensure that you continue to receive these valuable messages in your inbox, please add our email address [info@packstrategies.com](mailto:info@packstrategies.com) to your address book.

\*You have received this notice because you are a qualified industry professional who subscribes to a BWP Media product. If you do not wish to receive sponsored notifications from BWP Media's advertising partners, please [click here](#) to be removed from marketing lists.

By clicking an advertiser content within this email, you consent for your information to be shared with BWP Media's advertising partner(s). Your privacy is important to us. You can view our privacy notice and [click here](#) to learn more about our privacy practices and how we [collect, use, and share](#) your information. We will not sell, rent, lease, or otherwise disclose your information to third parties without your consent. You can opt out of our use of your personal information.

### Packaging Strategies – MUST VISIT

#### Featured Solutions:

CP eMerge™ Combo | Meta® Duo | BoxSizer® Right-Sizing Technology | Pak On Demand™ Pouch System

# LEAD GENERATION E-BLASTS

## TRADE PUBLICATIONS



**CANADIAN+ PACKAGING**  
A MESSAGE FROM OUR SPONSOR

**WestRock**

Introducing WestRock's newest automation technology for frozen food bowls.

WestRock's CP eMerge™ Combo for frozen food bowls combines sustainable secondary and tertiary packaging into one system. The single-operator, end-of-line solution manages multiple SKUs and minimizes downtime by allowing for quick changeover between a range of bowls and trays. The integrated combo design is uniquely suitable for those with footprint constraints.

**Complexity, simplified.**

Visit our virtual showroom at PACK EXPO Connects, November 9-13, 2020 to see it in action.

[LEARN MORE](#)

WestRock  
Contact us

CASL | Privacy | Accessibility | Unsubscribe

Copyright ©2020 Amex Business Media  
P.O. Box 530, 195 Dandy Drive S, Simcoe, ON, CANADA N3Y 4N6  
customerservice@amexbusinessmedia.com  
Customer Service: Tel 1-800-668-2274

Deployment Date: 9/1/20  
Leads: 18



**CANADIAN+ PACKAGING**  
A MESSAGE FROM OUR SPONSOR

**WestRock**

Streamline your e-commerce operations with automated right-sized packaging solutions.

From our Pak On Demand™ Pouch System which creates curbside recyclable matters to our multiple box footprint right-sizing machine, BoxSizer®, WestRock's two newest right-sizing technologies offer sustainability and optimized performance. Check out how these systems can help you reduce shipping and labor costs, eliminate packaging waste and void fill, and solve for package variability while increasing throughput. Visit our virtual showroom pe show158 at PACK EXPO Connects, November 9-13, 2020.

[LEARN MORE](#)

WestRock  
Contact us

CASL | Privacy | Accessibility | Unsubscribe

Copyright ©2020 Amex Business Media  
P.O. Box 530, 195 Dandy Drive S, Simcoe, ON, CANADA N3Y 4N6  
customerservice@amexbusinessmedia.com  
Customer Service: Tel 1-800-668-2274

Deployment Date: 9/24/20  
Leads: 15



**CANADIAN+ PACKAGING**  
A MESSAGE FROM OUR SPONSOR

**WestRock**

Multiple channels. One solution.

WestRock's Meta® Duo offers true multi-channel, in-house automation of one- and two-piece shell-sty packaging designs and ship-in-own container (SIOC) units. Utilizing our unique Meta® Systems precision-forming technology, Meta Duo efficiently transitions between 4-sided, 8-sided and half-slotted containers (HSCs), helping you meet various retailer and e-tailer requirements from a single, small footprint machine.

Visit our virtual showroom pe show158 at PACK EXPO Connects, November 9-13, 2020.

[LEARN MORE](#)

WestRock  
Contact us

CASL | Privacy | Accessibility | Unsubscribe

Copyright ©2020 Amex Business Media  
P.O. Box 530, 195 Dandy Drive S, Simcoe, ON, CANADA N3Y 4N6  
customerservice@amexbusinessmedia.com  
Customer Service: Tel 1-800-668-2274

Deployment Date: 10/5/20  
Leads: 10



**CANADIAN+ PACKAGING**  
A MESSAGE FROM OUR SPONSOR

**WestRock**

Looking for fiber alternatives to plastic cans and bottle packs?

The CanCollar® Fortuna™ system is the fastest and most flexible solution for fiber-based alternatives to plastic rings and shrink film can packs. As a small footprint machine, the Elite Fortuna fits seamlessly into existing line layouts and delivers speeds of up to 600 spots per minute.

See a live demo! Visit our virtual showroom pe show158 at PACK EXPO Connects, November 9-13, 2020.

[LEARN MORE](#)

WestRock  
Contact us

CASL | Privacy | Accessibility | Unsubscribe

Copyright ©2020 Amex Business Media  
P.O. Box 530, 195 Dandy Drive S, Simcoe, ON, CANADA N3Y 4N6  
customerservice@amexbusinessmedia.com  
Customer Service: Tel 1-800-668-2274

Deployment Date:  
10/16/20  
Leads: 23

### Canadian Packaging – Sponsored E-blasts

#### Featured Solutions:

CP eMerge™ Combo | E-commerce – BoxSizer® Right-Sizing Technology & Pak On Demand™ Pouch System | Meta® Duo | CanCollar® Fortuna™

# LEAD GENERATION E-BLASTS

## TRADE PUBLICATIONS

10/25/2020

### prepared FOODS MUST SEE

Hi Diana,

On behalf of our entire team, we hope you're enjoying Prepared Foods. Prepared Foods exists to inspire and inform all food and beverage manufacturer professionals who collaborate and develop new products for all channels of distribution. **Must See Products** showcases the latest innovations entering the prepared foods market today. Click on the links provided and learn more about the products that will help you take your business to the next level!

Bob Garrison, Editor in Chief, Prepared Foods

Sponsored by 

**Complexity, Simplified.**  
Doing more with less? Less time. Less space. Less labor resources.

Introducing the CP eMerge™ Combo, WestRock's newest automation technology for food bowls that combines sustainable secondary and tertiary packaging into one system. The single-operator, end-of-line solution manages multiple SKUs and minimizes downtime by allowing for quick changeover between a range of bowl and tray. The integrated combo design is uniquely suitable for those with footprint constraints.



[Click here for more!](#)

### Prepared Foods – MUST VISIT

Featured Solution:  
CP eMerge™ Combo

More from Prepared Foods

**Q&A with Gail Feinreich, Little Wave Co.**  
Prepared Foods talks innovation strategy with Gail Feinreich founder and principal consultant at Little Wave Co., Los Angeles. Feinreich's 23+ year career spans a range of companies from start-ups to multinationals across industries from enterprise software to sports nutrition and food. [Read Story](#)

**'Project Pathways' to Promote Representation of Black, Indigenous, People of Color in the Consumer-Packaged Goods Space**  
The consumer packaged goods (CPG) sector has long failed to represent the makeup of today's US population, specifically Black, Indigenous, People of Color (BIPOC) who support and fuel the category. Looking to promote positive, long-lasting change, Larabean Bear, Founder and CEO of A Douen Cousins, started Project Pathways as a first-of-its-kind organization to help BIPOC thrive in the CPG industry. [Read Story](#)

**\$1.5 billion Invested in Alternative Proteins in 2020**  
According to report produced by The Good Food Institute (GFI), 2019 and the first seven months of 2020 were record periods of investment in fermentation companies creating sustainable alternatives to conventional animal-based foods and ingredients. [Read Story](#)



**prepared FOODS Want more?**

Copyright © 2020 by PFM Media, LLC  
2020 11th Edition, Issue 99  
100% No Ad Spend

To ensure that you continue to receive these useful messages in your inbox, please visit our email dashboard [HERE](#) for more information.

You have received this notice because you are a qualified sales professional who subscribes to a PFM Media product. If you do not wish to receive anymore notifications from PFM Media advertising partners, please click on the link provided for learning about your options.

By clicking on an advertiser's name within this email, you consent for your information to be shared with PFM Media advertising partners. Your message is intended for you. You are not to be released from our Privacy Policy, or from our most about our privacy practices and the terms our Terms of Use. DO NOT SELL MY PERSONAL INFORMATION. California residents can click on this link to opt-out of the sale of their personal information.

Deployment Date:  
10/25/20  
Leads: 10

### Packaging Word – Video Spotlight

Featured Solution:  
Pak On Demand™ Pouch System

**PACKAGING Video Spotlight**

**Reduce labor with right-sized automation.**



WestRock's Pak On Demand™ Pouch System 3D scans products on a conveyor, creates a custom, right-sized, curbside recyclable pouch on demand and seals the package for shipment—all with a single operator. The streamlined process not only reduces labor costs, it also eliminates unnecessary void fill and shipping charges and increases packing rates up to five times over manual operations. Right sized. Right now. Visit our virtual showrooms at PACK EXPO Connects November 9-13, 2020.

[LEARN MORE](#)

Brought to you by 

This email was sent to [diana.furber@westrock.com](mailto:diana.furber@westrock.com) by PFM Media Group, 401 N. Michigan Avenue, Suite 300 Chicago, IL 60611, United States of America. Please include your email, LinkedIn, Facebook | Twitter | Instagram

 This email was sent by PFM Media Group, publisher of Packaging World, Automation World, Healthcare Packaging, Contract Packaging, CPM, PFM Food and More! PFM Media Group is a division of PFM, owner and publisher of the global portfolio of PACK EXPO shows. You are receiving this communication because of your subscription to one or more of PFM's publications, your attendance at one of PFM's seminars or trade shows, or prior download from one of PFM's websites. By clicking on PFM's logo below, you have provided your consent for PFM to provide and share your personal data with its customers of communicating with you. Your consent for PFM to collect and use this data will remain active until expressly revoked by you. All questions regarding data privacy process, practices, or policies, or as well as requests to review consent can be addressed to [dataprotection@pfm.com](mailto:dataprotection@pfm.com). All content in this email is generated and sent not distributed by PFM Media Group. PFM Media Group may share your contact information with sponsors as detailed in our [privacy policy](#), but we will NEVER share your contact information with a sponsor unless you have not opted out. However, PFM may also make use of your data for other communication purposes, such as to inform you of other important industry developments, programs, or publications that may be relevant.

Deployment Date: 9/5/20  
Leads: 98

# LEAD GENERATION E-BLASTS

SHOW SPONSORED

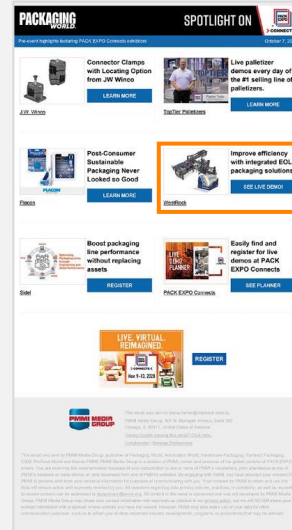

Deployment Date:  
10/7/20  
Leads: 24

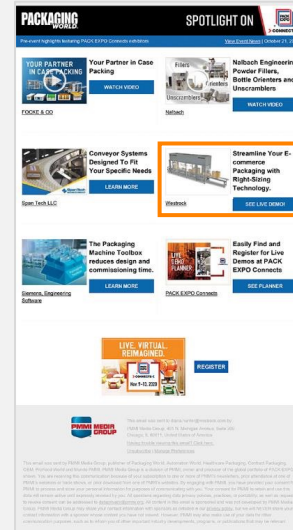

Deployment Date:  
10/21/20  
Leads: 23

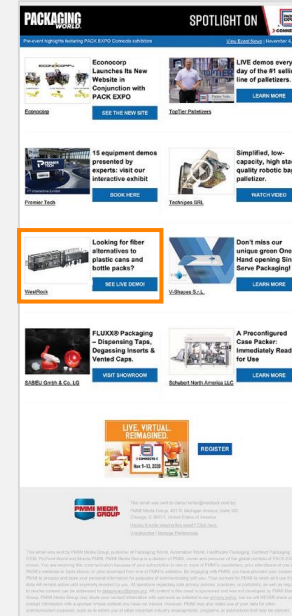

Deployment Date:  
11/4/20  
Leads: 22

PMMI Media Group – **Spotlight on PACK EXPO Connects**

Featured Solutions:

CP eMerge™ Combo | BoxSizer® Right-Sizing Technology | CanCollar® Fortuna™

# LEAD GENERATION E-BLASTS

## SHOW SPONSORED

**E-COMMERCE EXHIBITOR PREVIEWS**  
October 9-11, 2020

Watch over 100 exhibitors at the premier global virtual event for packaging.

Virtual Event Registration | View Demo Line-Up | Preview Products

**Streamline Your E-commerce Packaging with Right-Sizing Technology**  
BoxSizer® is the only machine on the market that can right-size multiple pre-sized box designs arriving at random from the internet without the need for changeovers. See a live demo! [View this Exhibitor](#)

**Automation Solutions for Omni-Channel Fulfillment**  
FANUC is the leader in robotic applications for omni-channel fulfillment. When you are ready to automate your fulfillment or logistics operations, let FANUC help you find a solution that works at the ROI you need. [View this Exhibitor](#)

**Kill Pathogens and Give Your People a Better Work Environment in 2021**  
Take back peace of mind and deliver the space your workers require with our Clean Air System technologies, independently tested and proven to kill re-emerged SARS-CoV-2 among other pathogens. Sign up for a demo and see our solutions at work! [View this Exhibitor](#)

**Cost and Sustainability Improvements for Secondary Packaging**  
View a demo of Cylar® HPC, a strong, secure solution that delivers flexibility, sustainability, and cost savings throughout the supply chain. See how it eliminates outer layer damage, reduces OMA weight/shipping cost, adapts to multiple SKUs, and more! [View this Exhibitor](#)

**More E-commerce to See!**  
Want a fast and easy way to tour this product category at PACK EXPO Connects? Check out these searchable tools: [Live Demo Platform](#) | [Product Preview](#)

**Making the Most of PACK EXPO Connects**  
**LIVE, VIRTUAL. REIMAGINED.**

**4 Tips for Using Chat at PACK EXPO Connects**  
PACK EXPO Connects makes it easy to connect directly with engineers and other experts at top suppliers. Read here for ways to optimize this opportunity. [Make the most of meeting via chat...](#)

**What Will You Find at PACK EXPO Connects?**  
PACK EXPO Connects is the global virtual event focusing on all things packaging and processing. Use this quick summary to view top highlights you can expect to see Nov. 9-13. [See PACK EXPO Connects A-to-Z here...](#)

**Are You Current with Packaging Best Practices?**  
From robotics to COVID-19, don't miss these dynamic and fast-paced daily kick-off presentations that address the industry's most pressing issues. [View the topic list...](#)

**PMMI MEDIA GROUP**  
This email was sent to: diana.hart@westrock.com by: PMMI Media Group, 401 N. Michigan Avenue, Suite 300, Chicago, IL 60611, United States of America. [View this Exhibitor](#) | [Unsubscribe](#) | [Manage Preferences](#)

This email was sent by PMMI Media Group, publisher of Packaging World, Automation World, Healthcare Packaging, Contract Packaging, ODM, Product World and more. PMMI Media Group is a division of PMMI, owner and publisher of the global portfolio of PACK EXPO shows. You are receiving this promotional message as you subscribed to one or more of PMMI's newsletters, your selection of one of PMMI's websites or trade shows, or your consent from one of PMMI's websites. By engaging with PMMI, you have provided your consent for PMMI to process and store your personal information for purposes of administering such work. Your consent for PMMI to collect and use this data will remain active until expressly revoked by you. All questions regarding data privacy policies, practices, or portability, as well as requests to review or correct your information, should be directed to: [privacy@packworld.com](mailto:privacy@packworld.com). All content in this email is operational and may be considered by PMMI Media Group. PMMI Media Group may share your contact information with vendors as outlined in our privacy policy. For our full privacy policy, please visit [www.pmmi.com/privacy](http://www.pmmi.com/privacy). We appreciate your interest in our work and we will continue to provide you with the latest news and information. PMMI may use your contact information for other purposes, such as to inform you of other relevant industry developments, programs, or opportunities that may be relevant.

Deployment Date: 9/27/20  
Leads: 79

**END-OF-LINE EQUIPMENT EXHIBITOR PREVIEWS**  
October 1, 2020

Watch over 100 exhibitors at the premier global virtual event for packaging.

Virtual Event Registration | View Demo Line-Up | Preview Products

**Simple Robotic Solutions for Complex Packaging Challenges**  
Watch NOVA Automation leaders explain how they approach complex packaging processes, creating opportunities for increased production and so much more. Register for a demo today! [View this Exhibitor](#)

**Columbia's Innovations in Palletizing and Package Handling**  
Join us for our demo to find out how Columbia's approach to innovation has been driven by demand from our customers to build the most flexible palletizers available. [View this Exhibitor](#)

**Improve Efficiency & Material Use with Integrated Packaging Solutions**  
Introducing CP eMerge™ Combo—our newest technology for tool heads that combines sustainable secondary and tertiary packaging into one system. See it in action! [View this Exhibitor](#)

**The Elmatic 2001: THE Most Flexible Case Packer**  
View a live demonstration of the Elmatic 2001, our new high-speed case packer. It features maximum flexibility and a small footprint, enabling top performance. The Elmatic 2001 represents an investment in your future. [View this Exhibitor](#)

**High-speed Pallet Wrapping's One-Two Punch: The MA-DX LoPro**  
See how the rapid pace performance of the 28 RPM MA-DX Automatic Stretch Wrapper teams up with the smooth, 60 feet-per-minute LoPro Drag Chain Conveyor, handling up to three 2,000 lb. pallets at a time to improve throughput and minimize downtime. [View this Exhibitor](#)

**Get a Sneak Peek of What to Expect at PACK EXPO Connects**  
Watch this video to learn what PACK EXPO Connects is all about. You won't want to miss live interactive product demos and chats with technical experts. (See for yourself!) Registration is free. [Watch Now](#)

**PMMI MEDIA GROUP**  
This email was sent to: diana.hart@westrock.com by: PMMI Media Group, 401 N. Michigan Avenue, Suite 300, Chicago, IL 60611, United States of America. [View this Exhibitor](#) | [Unsubscribe](#) | [Manage Preferences](#)

This email was sent by PMMI Media Group, publisher of Packaging World, Automation World, Healthcare Packaging, Contract Packaging, ODM, Product World and more. PMMI Media Group is a division of PMMI, owner and publisher of the global portfolio of PACK EXPO shows. You are receiving this promotional message as you subscribed to one or more of PMMI's newsletters, your selection of one of PMMI's websites or trade shows, or your consent from one of PMMI's websites. By engaging with PMMI, you have provided your consent for PMMI to process and store your personal information for purposes of administering such work. Your consent for PMMI to collect and use this data will remain active until expressly revoked by you. All questions regarding data privacy policies, practices, or portability, as well as requests to review or correct your information, should be directed to: [privacy@packworld.com](mailto:privacy@packworld.com). All content in this email is operational and may be considered by PMMI Media Group. PMMI Media Group may share your contact information with vendors as outlined in our privacy policy. For our full privacy policy, please visit [www.pmmi.com/privacy](http://www.pmmi.com/privacy). We appreciate your interest in our work and we will continue to provide you with the latest news and information. PMMI may use your contact information for other purposes, such as to inform you of other relevant industry developments, programs, or opportunities that may be relevant.

**More End-of-Line Equipment to See!**  
Want a fast and easy way to tour this product category at PACK EXPO Connects? Check out these searchable tools: [Live Demo Platform](#) | [Product Preview](#)

**Making the Most of PACK EXPO Connects**  
**LIVE, VIRTUAL. REIMAGINED.**

**Discover Success Strategies for Rapidly Changing Times**  
PACK EXPO Connects features exclusive educational content on most recent packaging trends, from changes in e-commerce to COVID-19 response. [View the Full Educational Line-Up and Discover Strategies on Top-Performing Shows Are Performing...](#)

**Want to See Truly New Products? It's Easier Than Ever**  
Once you've been to a fair number of packaging trade shows, it can feel like you've already seen much of what the marketplace has to offer. But not at PACK EXPO Connects! Learn how an independent connect is flagging industry innovations. [Learn How To See What's New...](#)

**Must-Knows for Navigating PACK EXPO Connects**  
With so many activities being planned at PACK EXPO Connects, you'll need to strategize how to spend your time. Here are a few tips to help you plan ahead, save time and get the most out of each day. [View This Tip...](#)

**PMMI MEDIA GROUP**  
This email was sent to: diana.hart@westrock.com by: PMMI Media Group, 401 N. Michigan Avenue, Suite 300, Chicago, IL 60611, United States of America. [View this Exhibitor](#) | [Unsubscribe](#) | [Manage Preferences](#)

This email was sent by PMMI Media Group, publisher of Packaging World, Automation World, Healthcare Packaging, Contract Packaging, ODM, Product World and more. PMMI Media Group is a division of PMMI, owner and publisher of the global portfolio of PACK EXPO shows. You are receiving this promotional message as you subscribed to one or more of PMMI's newsletters, your selection of one of PMMI's websites or trade shows, or your consent from one of PMMI's websites. By engaging with PMMI, you have provided your consent for PMMI to process and store your personal information for purposes of administering such work. Your consent for PMMI to collect and use this data will remain active until expressly revoked by you. All questions regarding data privacy policies, practices, or portability, as well as requests to review or correct your information, should be directed to: [privacy@packworld.com](mailto:privacy@packworld.com). All content in this email is operational and may be considered by PMMI Media Group. PMMI Media Group may share your contact information with vendors as outlined in our privacy policy. For our full privacy policy, please visit [www.pmmi.com/privacy](http://www.pmmi.com/privacy). We appreciate your interest in our work and we will continue to provide you with the latest news and information. PMMI may use your contact information for other purposes, such as to inform you of other relevant industry developments, programs, or opportunities that may be relevant.

Deployment Date: 10/1/20  
Leads: 8

### PMMI Media Group – Exhibitor Previews

Categories:  
E-commerce (BoxSizer®) | End-of-Line Equipment (CP eMerge™ Combo)

# LEAD GENERATION E-BLASTS

## SHOW SPONSORED

**END-OF-LINE EQUIPMENT**  
EXHIBITOR PREVIEWS

Multi-line exhibitors at the premiere global virtual event for packagers. **October 15, 2020**

Virtual Event Registration | View Demo Line-Up | Download Products

---

**Robatech Control System: Easy and Smart Control of Gluing Processes**

Stay in control and know how to optimize for reliable gluing, maximum system availability and reduced glue consumption. Our platform for easy system integration and operation, join the live demo.

[View this Exhibitor](#)

---

**Integration Driving Productivity**

Columbi@tura draws on nearly 25 years of packaging expertise to deliver dynamic products and services that increase productivity and reduce production downtime. View one of our live product demos and see how we can meet your needs!

[View this Exhibitor](#)

---

**Increase Performance with Packer for Bulk, Variety, and Single Flavor**

The Spider 300v case packer allows randomly fed or organized product and forms horizontal and vertical pack patterns on the same line. Watch it instantly pack pouches of dried fruit into cases and vertically pack a double face display at the same line.

[View this Exhibitor](#)

---

**Endless Opportunities with High-Speed Packaging**

Learn how combining Kawasack's VFCOM Delta robot, VFCOM robot system, and conveyor tracking can speed up production line at a low cost.

[View this Exhibitor](#)

---

**Increase Flexibility with Automated Self-Ready Packaging**

Meta® Duo offers true multi-channel, in-house automation of one- and two-piece shelf-ready packaging designs and allows in-line container units.

[View this Exhibitor](#)

---

**Innovation at Its Best with Complete Packaging Lines**

Our portfolio of end-of-line solutions transforms manufacturing. Ready for action? Don't miss our live demos on robotic case packing and depalletizing and build your own 3D packaging line live using our unique tool.

[View this Exhibitor](#)

**More End-of-Line Equipment to See!**

Want a fast and easy way to tour the product category at PACK EXPO Connects? Check out these searchable tools.

[Live Demo Planner](#) [Product Previews](#)

**Making the Most of PACK EXPO Connects**

**How to Sign Up for Live Demos at PACK EXPO Connects**

PACK EXPO Connects features more than 2,000 live product demos from leading packaging and processing suppliers. [View the Full Line-Up and Plan Your Day...](#)

**Are You Current with Packaging Best Practices?**

From robotics to COVID-19, don't miss these dynamic and fast-paced daily kick-off presentations that address the industry's most pressing issues. [View the 100K Live-Up...](#)

**What Will You Find At PACK EXPO Connects?**

PACK EXPO Connects is the global virtual event focusing on all things packaging and processing. Use this quick summary to view top highlights you can expect to see Nov. 9-13. [See PACK EXPO Connects At A Glance...](#)

**PMMI MEDIA GROUP**

This email was sent to Maria.Maria.Har@westrock.com by:  
Maria.Maria.Har@westrock.com, 401 N. Michigan Avenue, Suite 200  
Chicago, IL 60611, United States of America  
Company: PMMI Media Group  
Group: PMMI Media Group

This email was sent by PMMI Media Group, publisher of Packaging World, Automation World, Healthcare Packaging, Contract Packaging, OSEB, Product World and Market Pulse. PMMI Media Group is a division of PMMI, owner and publisher of the global portfolio of PACK EXPO shows. You are viewing this communication because of your subscription to one or more of PMMI's newsletters, and attendance at one of PMMI's exhibits or trade shows, or your connection from one of PMMI's websites. By engaging with PMMI, you have consented your connection to PMMI to provide and share your personal information for purposes of communicating with you. Your consent for PMMI to send and use this data will remain active until expressly notified by you. All questions regarding data privacy policies, practices, or preferences, as well as requests to review, correct, or delete your information, should be directed to: DataPrivacy@pmmi.com. All content in this email is sponsored and may not be developed by PMMI Media Group. PMMI Media Group may share your contact information with companies as detailed in our privacy policy. We will not sell your name and contact information to a sponsor whose product you have not viewed. However, PMMI may use your name for our own promotional purposes, such as to inform you of other relevant industry developments, subject to our policies that may be changed.

Deployment Date:  
10/15/20  
Leads: 18

**E-COMMERCE**  
EXHIBITOR PREVIEWS

Multi-line exhibitors at the premiere global virtual event for packagers. **October 26, 2020**

Virtual Event Registration | View Demo Line-Up | Download Products

---

**Shrink Film Solutions for E-Com Protection**

View a demo on shrink packaging that solves e-commerce headaches: strong, cost-effective encasement to contain powders, liquids, pellets, odors and flavors; proprietary packaging to eliminate bow-throughage.

[View this Exhibitor](#)

---

**Reduce Labor Cost with Right-Sized Automation**

Pak On Demand™ Pouch System 3D scans products; creates a right-sized, outside-recyclable pouch; and seals the package for shipment—all with a single operator.

[View this Exhibitor](#)

---

**Robotic Fulfillment – Perception Versus Reality – How To Succeed**

FANUC is leading the way for robotic applications in e-commerce. Our latest technologies will help you automate your fulfillment and logistics operations at the FCV you need. Don't miss our live product demo!

[View this Exhibitor](#)

---

**Package Process Ensures High-Performance Delivery**

To surmise the hazards of the e-commerce supply chain, we've created DISCS (Disp, Impact, Shock, Crush, Shake), a rigorous process that tests and ensures your packaging is designed to arrive as intended, every time. Live demo November 9th.

[View this Exhibitor](#)

---

**Protect Your Workers with Powerful Air Disinfection**

Lower your people's risk of infection with Big Air Fans' Clean Air System. Our powerful airflow and proven ion technology create safe, comfortable working conditions that keep your business on track. Mark your calendar for a live product demo!

[View this Exhibitor](#)

---

**Are You Making the Most of Your Unboxing Experience?**

Proven paper builds the brand connection that's often lost in e-commerce. By packing with brand colors and custom prints, companies stand out, increase customer value, and ultimately increase profitability. View our product demos and see how to better build brand loyalty.

[View this Exhibitor](#)

**More E-Commerce to See!**

Want a fast and easy way to tour the product category at PACK EXPO Connects? Check out these searchable tools.

[Live Demo Planner](#) [Product Previews](#)

**Making the Most of PACK EXPO Connects**

**Want to See Truly New Products? It's Easier Than Ever**

Once you've been to a fair number of packaging trade shows, it can feel like you've already seen much of what the marketplace has to offer. But not at PACK EXPO Connects! Learn how an independent committee is flagging industry innovations. [Learn How To See What's New...](#)

**Are You Current with Packaging Best Practices?**

From robotics to COVID-19, don't miss these dynamic and fast-paced daily kick-off presentations that address the industry's most pressing issues. [View the 100K Live-Up...](#)

**Must-Knows for Navigating PACK EXPO Connects**

With so many industries saving prices at PACK EXPO Connects, you'll need to strategize how to spend your time. Here are a few tips to help you plan ahead, save time and get the most out of each day. [View The Top...](#)

**PMMI MEDIA GROUP**

This email was sent to Maria.Maria.Har@westrock.com by:  
Maria.Maria.Har@westrock.com, 401 N. Michigan Avenue, Suite 200  
Chicago, IL 60611, United States of America  
Company: PMMI Media Group  
Group: PMMI Media Group

This email was sent by PMMI Media Group, publisher of Packaging World, Automation World, Healthcare Packaging, Contract Packaging, OSEB, Product World and Market Pulse. PMMI Media Group is a division of PMMI, owner and publisher of the global portfolio of PACK EXPO shows. You are viewing this communication because of your subscription to one or more of PMMI's newsletters, and attendance at one of PMMI's exhibits or trade shows, or your connection from one of PMMI's websites. By engaging with PMMI, you have consented your connection to PMMI to provide and share your personal information for purposes of communicating with you. Your consent for PMMI to send and use this data will remain active until expressly notified by you. All questions regarding data privacy policies, practices, or preferences, as well as requests to review, correct, or delete your information, should be directed to: DataPrivacy@pmmi.com. All content in this email is sponsored and may not be developed by PMMI Media Group. PMMI Media Group may share your contact information with companies as detailed in our privacy policy. We will not sell your name and contact information to a sponsor whose product you have not viewed. However, PMMI may use your name for our own promotional purposes, such as to inform you of other relevant industry developments, subject to our policies that may be changed.

Deployment Date:  
10/26/20  
Leads: 30

### PMMI Media Group – Exhibitor Previews

Categories:  
End-of-Line Equipment (Meta® Duo) | E-commerce (Pak On Demand™ Pouch System)

# LEAD GENERATION E-BLASTS

SHOW SPONSORED

**CARTONING & MULTIPACKING EXHIBITOR PREVIEWS**

Meet over 100 exhibitors at the premier global virtual event for packaging. November 6, 2020

**ADICO Manufacturing**  
**Cartoning Solutions that Exceed Your Expectations**  
At ADICO, we know that you need to cost-effectively improve efficiency, quality, and the productivity of your packaging. Visit our showroom to see cartoning solutions that meet your specific needs.  
[View this Exhibitor](#)

**Kwikpak**  
**Improve Efficiency & Material Use with Integrated Packaging Solutions**  
Introducing CP eMerge™ Combo—our newest technology for food bowls that combines sustainable secondary & tertiary packaging into one system. See it live event!  
[View this Exhibitor](#)

**Deltor Systems, Inc.**  
**Deltor's Quick Delivery Program & Cartoning DEMO!**  
We'll be demoing cartoning systems that perfectly inspect, correct, and close cartons at high speed! Learn about this smart tech as well as our core products program, which allows for 6-10 week machine delivery!  
[View this Exhibitor](#)

**Ocore Products**  
**Watch the American Debut of the Brand-New Kwikpak ACE Carton Former!**  
Designed for user ergonomics, ease flexibility with 1, 2, or 3 heads, easy operator access, and lock, glue, or ultrasonic bonding, the ACE is amazing! **FOUR LIVE DEMOS during the show!** Sign up NOW!  
[View this Exhibitor](#)

**PaTech**  
**PaTech Delivers 100% Recycled & Recyclable Packaging**  
PaTech delivers the highest quality packaging to the market with the least environmental impact. PaTech bundles are made with 100% recycled HDPE. Trust PaTech with your sustainable packaging needs. Visit our virtual booth to learn more!  
[View this Exhibitor](#)

**Graphic Packaging International**  
**Your Go-To for Multipack Machinery Solutions**  
View a high-speed multipacker for cans, bottles and PET. Sign up for a live demo of our sustainable paperboard clip solution applied at high speed via the KleeClip™ 1800. Don't miss other videos in our gallery for a variety of machinery solutions to increase your line efficiency.  
[View this Exhibitor](#)

**More Cartoning & Multipacking to See!**

Want a fast and easy way to tour this product category at PACK EXPO Connects? Check out these searchable tools:  
[Live Demo Planner](#) [Product Previews](#)

**Making the Most of PACK EXPO Connects** **LIVE, VIRTUAL, REIMAGINED.**

**Learn How to Search and Add Live Demos to Your Calendar (It's Super Easy!)**  
To navigate an event the size of PACK EXPO Connects, it's important to have an itinerary in advance. Watch how easy it is to search the 2,600 live demos to find what you need and add reminders to your calendar. [See how to search and add events.](#)

**Want to See Truly New Products? It's Easier Than Ever**  
Once you've been to a fair number of packaging trade shows, it can feel like you've already seen much of what the marketplace has to offer. But not at PACK EXPO Connects! Learn how an independent committee is tagging industry innovations. [Learn How To See What's New.](#)

**Get Direct Access to Technical Pros**  
Engineers, technical experts, PACK EXPO Connects has 'em. Get direct answers from those who can best understand your specific application or need. [Search exhibitors to schedule a chat!](#)

**PMMI MEDIA GROUP**  
This email was sent to [maria.hunter@westrock.com](mailto:maria.hunter@westrock.com) by PMMI Media Group, 401 N. Michigan Avenue, Suite 900, Chicago, IL 60611, United States of America. PMMI Media Group is an Equal Opportunity Employer.

**Deployment Date: 11/6/20  
Leads: 17**

PMMI Media Group – **Exhibitor Previews**  
Category:  
Cartoning & Multipacking (CP eMerge™ Combo)

# CO-BRANDED E-BLASTS

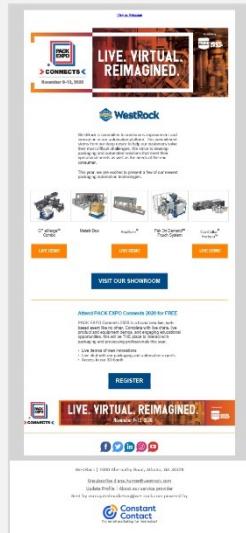

Date: 10/29/20  
 Sent: 55298  
 Open Rate: 15.1%  
 Click Rate: 15.7%



Date: 11/3/20  
 Sent: 85  
 Open Rate: 60.3%  
 Click Rate: 12.8%

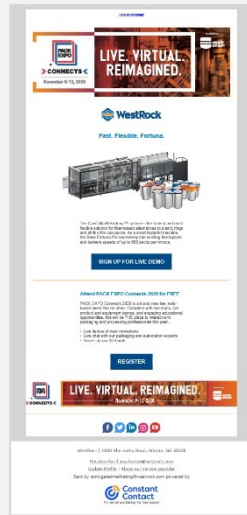

Date: 11/3/20  
 Sent: 2393  
 Open Rate: 14%  
 Click Rate: 15.6%

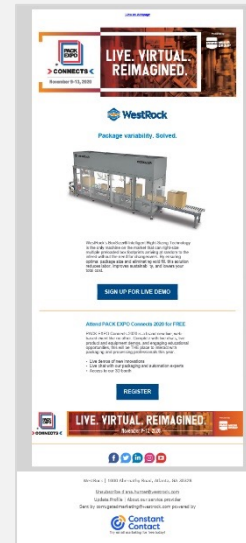

Date: 10/30/20  
 Sent: 619  
 Open Rate: 60.3%  
 Click Rate: 12.8%

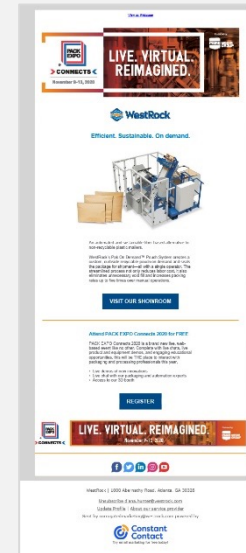

Date: 10/30/20  
 Sent: 618  
 Open Rate: 21.9%  
 Click Rate: 39.5%

PMMI Media Group – *Customer Invite Program*

Featured Solutions:

General Invite | CP eMerge™ Combo | CanCollar® Fortuna™ | BoxSizer® | Pak On Demand™ Pouch System



# RUN-OF-SITE WEB ADS

## TRADE PUBLICATIONS



REDUCE LABOR COST  
WITH RIGHT-SIZED AUTOMATION.

Visit our virtual showroom at PACK EXPO Connects.



westrock.com/pakondemand

300x250



REDUCE LABOR COST  
WITH RIGHT-SIZED AUTOMATION.

Visit our virtual showroom at PACK EXPO Connects.



westrock.com/pakondemand

728x90



IMPROVE EFFICIENCY  
WITH INTEGRATED END-OF-LINE SOLUTIONS.

westrock.com/automation 

Visit our virtual showroom at PACK EXPO Connects to learn more about our newest automation technology.

728x90



IMPROVE EFFICIENCY  
WITH INTEGRATED END-OF-LINE SOLUTIONS.



Visit our virtual showroom at PACK EXPO Connects.

320x50

*DC Velocity* September & October 2020

Featured Solution:  
Pak On Demand™ Pouch System

*Packaging Strategies* September 2020

Featured Solution:  
CP eMerge™ Combo

# RUN-OF-SITE WEB ADS

## TRADE PUBLICATIONS

**STREAMLINE YOUR PROCESSES WITH INTELLIGENT TECHNOLOGY.**

Visit our virtual showroom at PACK EXPO Connects to learn more about BoxSizer® Right-Sizing Technology.



[westrock.com/boxsizer](http://westrock.com/boxsizer)

300x250

**INCREASE FLEXIBILITY WITH AUTOMATED SHELF-READY PACKAGING.** | [westrock.com/metaduo](http://westrock.com/metaduo) 

Visit our virtual showroom at PACK EXPO Connects to learn more about Meta® Duo two-piece SRP technology.

728x90



**IMPROVE EFFICIENCY WITH INTEGRATED END-OF-LINE SOLUTIONS.**

Visit our virtual showroom at PACK EXPO Connects to learn more about our newest automation technology for frozen food bowls.



[westrock.com/automation](http://westrock.com/automation)

300x600

*Packaging World* September, October, November 2020

Featured Solutions:

BoxSizer® Right-Sizing Technology | Meta® Duo | CP eMerge™ Combo

# SOCIAL MEDIA



We're excited to be participating in the brand new live, web-based Pack Expo Connects 2020, taking place November 9-13<sup>th</sup>. We'll be debuting two of our new-to-market packaging automation innovations in live demos on Monday, November 9<sup>th</sup>. Register for free to attend our demonstrations and live chat with our experts about your packaging needs. (Include link to PEC landing page)

**Pre-Event Post:**  
Fri 10/23 @ 11 am EST



Introducing the CP eMerge™ Combo, WestRock's newest automation technology for food bowls that combines sustainable secondary and tertiary packaging into one system. See it in action during our Pack Expo connects 2020 live demo today at 12:30 CT. (Include link to WestRock's PEC page)

**Day 1:**  
Mon 11/9 @ 8 AM EST



If you are looking to optimize your e-commerce operations, we'll be doing a BoxSizer® live demo today at 12:15 CT during Pack Expo Connects 2020. BoxSizer is the only machine on the market that can right-size multiple preloaded box footprints arriving at random to the infeed without the need for changeovers. (Include link to WestRock's PEC page)

**Day 2:**  
Tues 11/10 @ 8 AM EST



Looking for sustainable packaging options for the beverage industry? We encourage you to check out one of our newest automation innovations, CanCollar® Fortuna™. This high-speed automation solution applies CanCollar, an optimized, sustainable, fiber-based packaging solution for multi-packing beverage cans and bottles. Our live demo takes place today at 12:15 CT during Pack Expo Connects 2020. (Include link to WestRock's PEC page)

**Day 3:**  
Wed 11/11 @ 8 AM EST

# SOCIAL MEDIA



If you've been looking for flexibility to fill both shelf-ready retail and e-commerce packaging orders in-house, check out WestRock's Meta® Duo. This innovative automation allows you to create one- and two-piece shelf ready packaging designs as well as ships-in-own-container units from a single small footprint machine. Learn more by visiting our 3D virtual environment or chat with one of our experts during Pack Expo Connects 2020. (Include line to 3D virtual booth)

**Day 4:**  
Thurs. 11/12 @ 8 AM EST



WestRock is an industry leader in the development and manufacturing of e-commerce packaging automation. Our performance-matched solutions help you simplify your packaging operation, optimize your supply chain, and achieve your sustainability goals. Click this link to learn more about WestRock's e-commerce solution Pak On Demand™ Pouch System, that creates custom, fiber-based recyclable pouches. (Include link to 3D virtual booth)

**Day 5:**  
Fri 11/13 @ 8 AM EST



We sincerely want to thank everyone who engaged with us during the Pack Expo Connects 2020 live event last week. If you didn't get a chance to check it out, our virtual booth will be available to view through March 31, 2021. Or navigate to our website to interact with our 3D environment by clicking this link. (Include link to 3D virtual booth)

**After Event Post:**  
Mon 11/16 @ 8 AM EST

# VIRTUAL 3D BOOTH

## FEATURED SOLUTIONS:

- CP EMERGE™ COMBO
- META® DUO
- BOXSIZER® RIGHT-SIZING TECHNOLOGY
- PAK ON DEMAND™ POUCH SYSTEM

# VIRTUAL 3D BOOTH

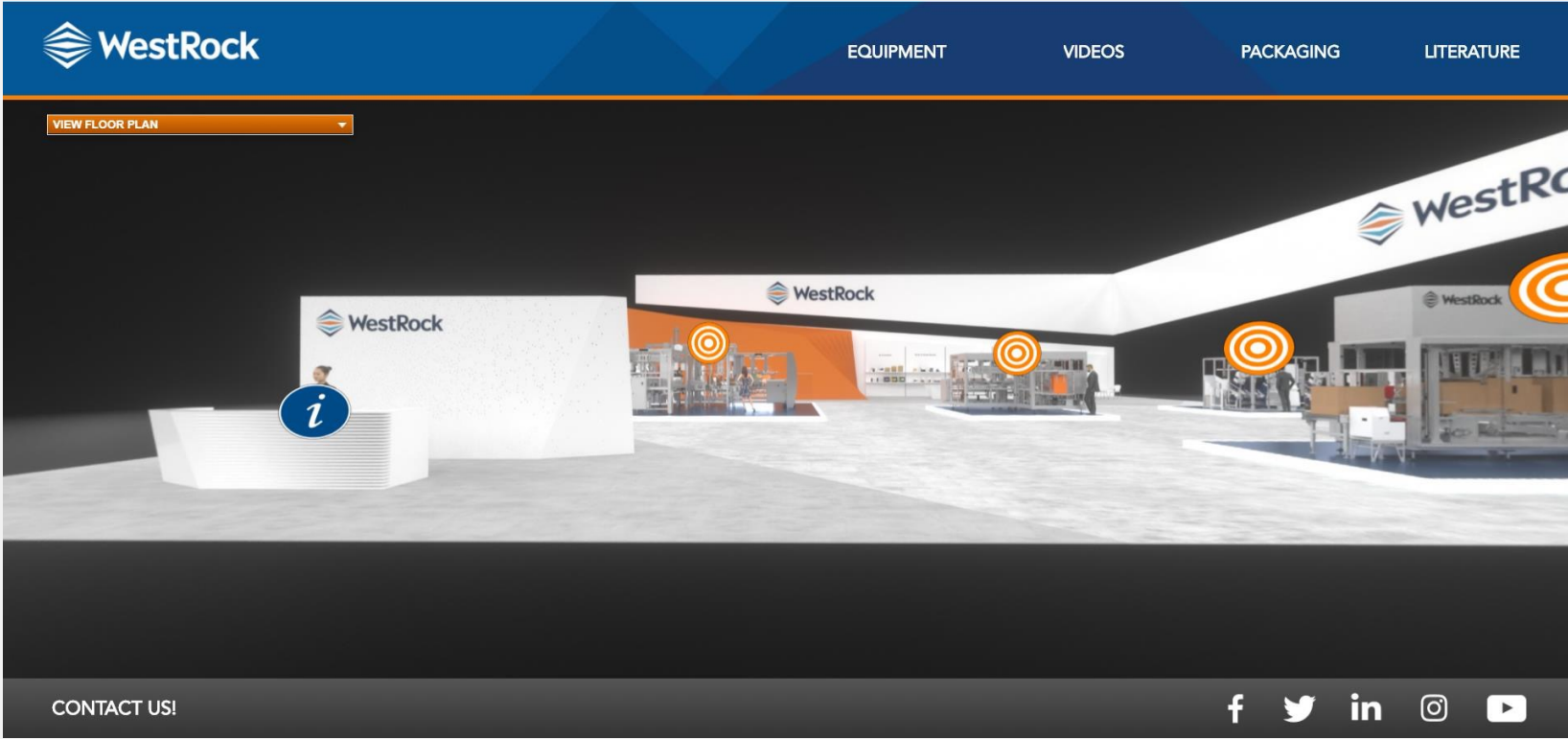

[WestRock.com/Showroom/](https://www.westrock.com/showroom/)

# NEXT YEAR'S SHOW

PACK EXPO LAS VEGAS

SEPTEMBER 27-29, 2021

LAS VEGAS CONVENTION CENTER

LAS VEGAS, NEVADA

# PACK EXPO LAS VEGAS

Island Booth  
52' x 110' (5,720 sq. ft.)

