



**TRI-COM BOARD OF DIRECTORS SPECIAL MEETING**  
**Special Meeting Agenda**  
**Wednesday, February 10, 2021**

Location: Virtual Meeting – information at the end of the agenda  
Time: 8:00 AM

Call Meeting to Order: Roll Call

Old Business: None

New Business:

- 1) Approval of Memo of Understanding with KaneComm for StarCom21
- 2) Approval of Memo of Understanding with Aurora Dispatch for StarCom21
- 3) Approval of Motorola Starcom21 Change Order 6
- 4) Approval of Electrical Work Procurement Process
- 5) Approval of Reef Contractors Change Order 4
- 6) Acceptance of Grant and Approval of Lighting Replacement Project

Public Comment:

Adjournment:

Next Regular Meeting: Wednesday, March 10, 2021 at 8:00 A.M.

To Access the February 10, 2021 Tri-Com Special Board Meeting:

Tri-Com Board of Directors Special Meeting  
Hosted by Michael Antenore

<https://michaelkantenore.my.webex.com/michaelkantenore.my/j.php?MTID=m9a5310a1934a8fcf4fa2d2607e39047e>

Wednesday, Feb 10, 2021 8:00 am | 1 hour | (UTC-06:00) Central Time (US & Canada)  
Meeting number: 182 654 5524  
Password: UyxMfpw66X4 (89963796 from phones and video systems)

Join by video system

Dial [1826545524@webex.com](tel:1826545524@webex.com)

You can also dial 173.243.2.68 and enter your meeting number.

Join by phone

+1-312-535-8110 United States Toll (Chicago)

Access code: 182 654 5524



**AGENDA ITEM EXECUTIVE SUMMARY**

Agenda Item:	StarCom Talk Group MOU's with Kane Comm		
Presenter & Title:	Joe Schelstreet, Executive Director		
Date:	February 10, 2021		
<b><i>Please Check Appropriate Box:</i></b>			
<input type="checkbox"/>	Regular Meeting	x	Special Meeting
<input type="checkbox"/>	Other -		
Estimated Cost: N/A		Budgeted? N/A	<b>YES</b>
			<b>NO</b>
<i>If NO, please explain how the item will be funded: N/A</i>			
<b>Executive Summary:</b>			
<p>Kane Comm is rapidly approaching their designated go-live date on the StarCom 21 system. They have indicated that they are ready to program their radios with our talk groups to facilitate better response interoperability. We had previously signed an MOU with Kane Comm to facilitate SWAT operations. These documents include both the talk groups that we were willing to share with Kane Comm and those that they would share with us. The MOU's have been reviewed and approved by our attorney.</p>			
<b>Voting Requirements:</b>			
<i>This motion requires a simple majority vote.</i>			
<b>Attachments:</b> <i>(please list)</i>			
Proposed updated StarCom Talk Group MOU's			
<b>Recommendation / Suggested Action:</b> <i>(briefly explain)</i>			
Staff requests approval of the proposed StarCom Talk Group MOU's with Kane Comm.			

## TALKGROUP ACCESS AGREEMENT

This agreement is hereby made and entered into this \_\_\_\_ day of \_\_\_\_\_, 21\_\_ by and between Tri Com Central Dispatch (hereinafter referred to as "Agency") and the Kane County Emergency Communications Center, (hereinafter referred to as "Kane Comm") and.

NOW, THEREFORE, for and in consideration of the mutual promises and covenants contained herein, the sufficiency of which is hereby mutually acknowledged, the parties hereto hereby agree as follows:

**Grant of Access.** Agency hereby authorizes Kane Comm and only those personnel members whose names Kane Comm provides to the Agency to access the following (hereinafter referred to collectively as "Talkgroups"):

PD 1, PD 2, TC TAC 1, TC TAC 2, Batavia OPS, North Aurora OPS, Elburn Ops, Geneva Ops, St. Charles Ops, Sugar Grove Ops, Fire Main, Fire South, KC SWAT

**Scope of Use.** Recognizing the need to control the use of these Talkgroups and in accordance with the State of Illinois Starcom21 policies and procedures, Kane Comm agrees to limit the use of the Talkgroups to Emergency Notifications (serious incidents, serious traffic crashes, and active fires), Coordination of Joint Operations and Mutual Aide Responses (Natural and Man-Made Disasters, Mass Casualty Incidents, Police, Fire, EMS, HAZMAT, Rescue Operations, and Training).

Kane Comm shall, at all times, ensure that its personnel utilize its access to Talkgroups in strict conformance with the provisions of this agreement, its application to the Agency, and such rules and policies as the Agency or its subordinate entities may from time to time establish. Kane Comm shall not permit its personnel to utilize Kane Comm access to Talkgroups in any manner that exceeds this scope of use or in violation of law.

**Termination.** Kane Comm may terminate its access to Talkgroups at any time by providing written notice to the Agency. The Agency may terminate Kane Comm access to Talkgroups at any time for any reason with or without written notice.

### **Indemnification.**

(a) Kane Comm shall, at all times, fully indemnify, hold harmless, and defend the Agency and its officers, agents, and employees from and against any and all claims and demands, actions, causes of action, and cost and fees of any character whatsoever made by anyone whomsoever on account of or in any way growing out of use of Talkgroup by Kane Comm and its employees, or because of any act or omission, neglect or misconduct of Kane Comm, its employees and agents or its subcontractors including, but not limited to, any claims that may be made by the employees themselves for injuries to their person or property or otherwise, and any claims that may be made by the employees themselves or by the Illinois Department of Labor for Kane Comm's violation of the Illinois Prevailing Wage Act (820 ILCS 130/1 et seq.). The foregoing obligation of Kane Comm to indemnify shall not be limited by reason of insurance or immunity.

(b) Nothing contained herein shall be construed as prohibiting the Agency and their officers, agents, or its employees, from defending through the selection and use of their own agents, attorneys and experts, any claims, actions or suits brought against them. Kane Comm shall likewise be liable for the costs, fees and expenses incurred in defense of any such claims, actions, or suits.

(c) Kane Comm shall be liable for any damages incurred as a result of its errors, omissions or negligent acts.

**Duty to Contract for Access, Costs.** Kane Comm shall contract with the applicable entity for access to the system on which the Talkgroup operates. Kane Comm shall be solely responsible for all costs associated with its access to the Talkgroup. Kane Comm shall be solely responsible for the acquisition of any equipment it requires to access Talkgroup.

**Notices.** All notices required to be given pursuant to this agreement shall be in writing and addressed to the parties at their respective addresses set forth below:

If to Kane Comm:  
Michelle Guthrie: Executive Director  
Kane Comm  
719 S Batavia Avenue  
Geneva, Illinois 60134

If to the Agency:  
Joe Schelstreet: Executive Director  
Tri Com Central Dispatch  
3823 Karl Madsen  
St. Charles, IL 60175

**Covenant Not to Sue.** In consideration of the Agency's grant of access to Talkgroups, Kane Comm covenants and agrees that it shall not sue, institute, cause to be instituted or permit to be instituted on its behalf, or by or on behalf of its past, present or future officials, officers, employees, attorneys, agents or assigns, any proceeding or other action with or before any local, state and/or federal agency, court or other tribunal, against the Agency, its Board of Directors, officers, commissioners, employees, attorneys, agents or assigns, arising out of, or from, or otherwise relating, directly or indirectly, to this agreement to the extent authorized by law. In no event shall the Agency be liable to Kane Comm for monetary damages for any reason whatsoever.

**Representations.** Kane Comm represents that it has the authority to enter into this agreement and undertake the duties and obligations contemplated by this agreement and that it has taken or caused to be taken all necessary action to authorize the execution. Further, Kane Comm represents that the signatory of this agreement has the authority to bind Kane Comm to all obligations herein contained.

**Survival.** Kane Comm's obligations pursuant to the sections herein under the headings entitled "Indemnification" and "Covenant Not to Sue" shall survive the termination of this agreement.

**Assignment.** Neither Kane Comm nor any of its personnel may assign or transfer any rights afforded to it under this agreement to any third party for any purpose without the express written permission of the Agency.

**Venue.** This agreement shall be subject to the laws of the State of Illinois. Venue for the resolution of any disputes or the enforcement of any rights arising out of or in connection with this agreement shall be in the Circuit Court of Kane County, Illinois.

**Severability.** The terms of this agreement shall be severable. In the event any of the terms or provisions of this agreement are deemed to be void or otherwise enforceable for any reason, the remainder of this agreement shall remain in full force and effect.

Tri-Com Central Dispatch:

Kane Comm:

By: \_\_\_\_\_  
Board Chairman

By: \_\_\_\_\_

Name/Print: \_\_\_\_\_

Attest:

Title: \_\_\_\_\_

\_\_\_\_\_  
Vice-Chair of the Board

## TALKGROUP ACCESS AGREEMENT

This agreement is hereby made and entered into this \_\_\_\_ day of \_\_\_\_\_, 20\_\_ by and between Kane County Emergency Communications (hereinafter referred to as "Agency") and Tri-Com Central Dispatch, (hereinafter referred to as "Tri-Com") and.

NOW, THEREFORE, for and in consideration of the mutual promises and covenants contained herein, the sufficiency of which is hereby mutually acknowledged, the parties hereto hereby agree as follows:

**Grant of Access.** Agency hereby authorizes Tri-Com and only those personnel members whose names Tri-Com provides to the Agency to access the following (hereinafter referred to collectively as "Talkgroups"):

KCSO Main  
KCSO 2 KC  
KCSO 3 KC  
KCSO 4 KC  
SP Event KC

**Scope of Use.** Recognizing the need to control the use of these Talkgroups and in accordance with the State of Illinois Starcom21 policies and procedures, Tri-Com agrees to limit the use of the Talkgroups to Emergency Notifications (serious incidents, serious traffic crashes, and active fires), Coordination of Joint Operations and Mutual Aide Responses (Natural and Man-Made Disasters, Mass Casualty Incidents, Police, Fire, EMS, HAZMAT, Rescue Operations, and Training).

Tri-Com shall, at all times, ensure that its personnel utilize its access to Talkgroups in strict conformance with the provisions of this agreement, its application to the Agency, and such rules and policies as the Agency or its subordinate entities may from time to time establish. Tri-Com shall not permit its personnel to utilize Tri-Com access to Talkgroups in any manner that exceeds this scope of use or in violation of law.

**Termination.** Tri-Com may terminate its access to Talkgroups at any time by providing written notice to the Agency. The Agency may terminate Tri-Com access to Talkgroups at any time for any reason with or without written notice.

### **Indemnification.**

(a) shall, at all times, fully indemnify, hold harmless, and defend the Agency and its officers, agents, and employees from and against any and all claims and demands, actions, causes of action, and cost and fees of any character whatsoever made by anyone whomsoever on account of or in any way growing out of use of Talkgroup by Tri-Com and its employees, or because of any act or omission, neglect or misconduct of Tri-Com, its employees and agents or its subcontractors including, but not limited to, any claims that may be made by the employees themselves for injuries to their person or property or otherwise, and any claims that may be made

by the employees themselves or by the Illinois Department of Labor for Tri-Com's violation of the Illinois Prevailing Wage Act (820 ILCS 130/1 et seq.). The foregoing obligation of Tri-Com to indemnify shall not be limited by reason of insurance or immunity.

(b) Nothing contained herein shall be construed as prohibiting the Agency and their officers, agents, or its employees, from defending through the selection and use of their own agents, attorneys and experts, any claims, actions or suits brought against them. Tri-Com shall likewise be liable for the costs, fees and expenses incurred in defense of any such claims, actions, or suits.

(c) Tri-Com shall be liable for any damages incurred as a result of its errors, omissions or negligent acts.

**Duty to Contract for Access, Costs.** Tri-Com shall contract with the applicable entity for access to the system on which the Talkgroup operates. Tri-Com shall be solely responsible for all costs associated with its access to the Talkgroup. Tri-Com shall be solely responsible for the acquisition of any equipment it requires to access Talkgroup.

**Notices.** All notices required to be given pursuant to this agreement shall be in writing and addressed to the parties at their respective addresses set forth below:

If to Tri-Com:  
Joe Schelstreet: Executive Director  
Tri-Com Central Dispatch  
3823 Karl Madsen  
St. Charles, IL 60175

If to the Agency:  
Michelle Guthrie: Executive Director  
KaneComm  
719 Batavia Ave, Bldg C  
Geneva, IL 60134

**Covenant Not to Sue.** In consideration of the Agency's grant of access to Talkgroups, Tri-Com covenants and agrees that it shall not sue, institute, cause to be instituted or permit to be instituted on its behalf, or by or on behalf of its past, present or future officials, officers, employees, attorneys, agents or assigns, any proceeding or other action with or before any local, state and/or federal agency, court or other tribunal, against the Agency, its Board of Directors, officers, commissioners, employees, attorneys, agents or assigns, arising out of, or from, or otherwise relating, directly or indirectly, to this agreement to the extent authorized by law. In no event shall the Agency be liable to Tri-Com for monetary damages for any reason whatsoever.

**Representations.** Tri-Com represents that it has the authority to enter into this agreement and undertake the duties and obligations contemplated by this agreement and that it has taken or caused to be taken all necessary action to authorize the execution. Further, Tri-Com represents that the signatory of this agreement has the authority to bind Tri-Com to all obligations herein contained.

**Survival.** Tri-Com's obligations pursuant to the sections herein under the headings entitled "Indemnification" and "Covenant Not to Sue" shall survive the termination of this agreement.



**Assignment.** Neither Tri-Com nor any of its personnel may assign or transfer any rights afforded to it under this agreement to any third party for any purpose without the express written permission of the Agency.

**Venue.** This agreement shall be subject to the laws of the State of Illinois. Venue for the resolution of any disputes or the enforcement of any rights arising out of or in connection with this agreement shall be in the Circuit Court of Kane County, Illinois.

**Severability.** The terms of this agreement shall be severable. In the event any of the terms or provisions of this agreement are deemed to be void or otherwise enforceable for any reason, the remainder of this agreement shall remain in full force and effect.

Kane County Emergency Communications:

Tri-Com Central Dispatch:

By: \_\_\_\_\_

By: \_\_\_\_\_

Name/Print: \_\_\_\_\_

Attest:  
\_\_\_\_\_

Title: \_\_\_\_\_

Title:  
\_\_\_\_\_



**AGENDA ITEM EXECUTIVE SUMMARY**

Agenda Item:	StarCom Talk Group MOU with the City of Aurora		
Presenter & Title:	Joe Schelstreet, Executive Director		
Date:	February 10, 2021		
<b><i>Please Check Appropriate Box:</i></b>			
<input type="checkbox"/>	Regular Meeting	x	<input type="checkbox"/> Special Meeting
<input type="checkbox"/>	Other -		
Estimated Cost: N/A		Budgeted? N/A	<b>YES</b>
			<b>NO</b>
<i>If NO, please explain how the item will be funded: N/A</i>			
<b>Executive Summary:</b>			
<p>At this time, the North Aurora Police Department has installed StarCom 21 radios in their squad cars and the City of Aurora has communicated their desire to work towards a higher level of inter-operability with the surrounding agencies that currently operate on the StarCom network. A talk group MOU has been proposed and it includes only the talk groups that we are willing to share with the City of Aurora (as well as the North Aurora PD) as they currently operate on the Open Sky network and not StarCom. The North Aurora Police and Fire Departments would experience an immediate enhancement as they could communicate on the same platform. Our attorney has reviewed and approved the MOU.</p>			
<b>Voting Requirements:</b>			
<i>This motion requires a simple majority vote.</i>			
<b>Attachments:</b> <i>(please list)</i>			
Proposed updated StarCom Talk Group MOU			
<b>Recommendation / Suggested Action:</b> <i>(briefly explain)</i>			
Staff requests approval of the proposed StarCom Talk Group MOU with the City of Aurora.			

## TALKGROUP ACCESS AGREEMENT

This agreement is hereby made and entered into this \_\_\_\_ day of \_\_\_\_\_, 20\_\_ by and between Tri Com Central Dispatch, an Illinois Intergovernmental Cooperation Agency of the Cities of St. Charles, Batavia and Geneva, Illinois (hereinafter referred to as "Agency") and the City of Aurora, Illinois, a municipal corporation (hereinafter referred to as "City").

NOW, THEREFORE, for and in consideration of the mutual promises and covenants contained herein, the sufficiency of which is hereby mutually acknowledged, the parties hereto hereby agree as follows:

**Grant of Access.** The Agency hereby authorizes the City and only those personnel members whose names the City provides to the Agency to access the following (hereinafter referred to collectively as "Talkgroups"):

PD 1, PD 2, TC TAC 1, TC TAC 2, Batavia OPS, North Aurora OPS, Elburn Ops, Geneva Ops, St. Charles Ops, Sugar Grove Ops, Fire Main, Fire South

**Scope of Use.** Recognizing the need to control the use of these Talkgroups and in accordance with the State of Illinois Starcom21 policies and procedures, the City agrees to limit the use of the Talkgroups to Emergency Notifications (serious incidents, serious traffic crashes, and active fires), Coordination of Joint Operations and Mutual Aide Responses (Natural and Man-Made Disasters, Civil Disturbance, Mass Casualty Incidents, Police, Fire, EMS, HAZMAT, Rescue Operations, and Training).

The City shall, at all times, ensure that its personnel utilize its access to Talkgroups in strict conformance with the provisions of this agreement, its application to the Agency, and such rules and policies as the Agency or its subordinate entities may from time to time establish. The City shall not permit its personnel to utilize the City's access to Talkgroups in any manner that exceeds this scope of use or in violation of law.

**Termination.** The City may terminate its access to Talkgroups at any time by providing written notice to the Agency. The Agency may terminate the City's access to Talkgroups at any time for any reason with or without written notice.

### **Indemnification.**

(a) The City shall, at all times, fully indemnify, hold harmless, and defend the Agency and their officers, agents, and employees from and against any and all claims and demands, actions, causes of action, and cost and fees of any character whatsoever made by anyone whomsoever on account of or in any way growing out of use of Talkgroup by the City and its employees, or because of any act or omission, neglect or misconduct of the City, its employees and agents or its subcontractors including, but not limited to, any claims that may be made by the employees themselves for injuries to their person or property or otherwise, and any claims that may be made by the employees themselves or by the Illinois Department of Labor for the City's violation of the

Illinois Prevailing Wage Act (820 ILCS 130/1 et seq.). The foregoing obligation of the City to indemnify shall not be limited by reason of insurance or immunity.

(b) Nothing contained herein shall be construed as prohibiting the Agency and their officers, agents, or its employees, from defending through the selection and use of their own agents, attorneys and experts, any claims, actions or suits brought against them. The City shall likewise be liable for the costs, fees and expenses incurred in defense of any such claims, actions, or suits.

(c) The City shall be liable for any damages incurred as a result of its errors, omissions or negligent acts.

**Duty to Contract for Access, Costs.** The City shall contract with the applicable entity for access to the system on which the Talkgroup operates. The City shall be solely responsible for all costs associated with its access to the Talkgroup. The City shall be solely responsible for the acquisition of any equipment it requires to access Talkgroup.

**Notices.** All notices required to be given pursuant to this agreement shall be in writing and addressed to the parties at their respective addresses set forth below:

If to the City:  
Commander Rick Robertson  
Aurora Police Department  
1200 E. Indian Trail  
Aurora, Illinois 60505

If to the Agency:  
Joe Schelstreet, Executive Director  
Tri Com Central Dispatch  
3823 Karl Madsen  
St. Charles, IL 60175

**Covenant Not to Sue.** In consideration of the Agency's grant of access to Talkgroups, the City covenants and agrees that it shall not sue, institute, cause to be instituted or permit to be instituted on its behalf, or by or on behalf of its past, present or future officials, officers, employees, attorneys, agents or assigns, any proceeding or other action with or before any local, state and/or federal agency, court or other tribunal, against the Agency, its council members, officers, commissioners, employees, attorneys, agents or assigns, arising out of, or from, or otherwise relating, directly or indirectly, to this agreement to the extent authorized by law. In no event shall the Agency be liable to the City for monetary damages for any reason whatsoever.

**Representations.** The City represents that it has the authority to enter into this agreement and undertake the duties and obligations contemplated by this agreement and that it has taken or caused to be taken all necessary action to authorize the execution. Further, the City represents that the signatory of this agreement has the authority to bind the City to all obligations herein contained.

**Survival.** The City's obligations pursuant to the sections herein under the headings entitled "Indemnification" and "Covenant Not to Sue" shall survive the termination of this agreement.

**Assignment.** Neither the City nor any of its personnel may assign or transfer any rights afforded to it under this agreement to any third party for any purpose without the express written permission of the Agency.

**Venue.** This agreement shall be subject to the laws of the State of Illinois. Venue for the resolution of any disputes or the enforcement of any rights arising out of or in connection with this agreement shall be in the Circuit Court for the 16<sup>th</sup> Judicial Circuit, Kane County, Illinois.

**Severability.** The terms of this agreement shall be severable. In the event any of the terms or provisions of this agreement are deemed to be void or otherwise enforceable for any reason, the remainder of this agreement shall remain in full force and effect.

CITY OF AURORA:

AGENCY:

By: \_\_\_\_\_  
Mayor

By: \_\_\_\_\_

Name/Print: \_\_\_\_\_

Attest:

Title: \_\_\_\_\_

\_\_\_\_\_  
City Clerk



**AGENDA ITEM EXECUTIVE SUMMARY**

Agenda Item:	Approval of StarCom Change Order #6		
Presenter & Title:	Joe Schelstreet, Executive Director		
Date:	February 10, 2021		
<b><i>Please Check Appropriate Box:</i></b>			
<input type="checkbox"/>	Regular Meeting	x	Special Meeting _____
<input type="checkbox"/>	Other -		
Estimated Cost: \$24,598		Budgeted?	<b>YES</b> <b>NO X</b>
<i>If NO, please explain how the item will be funded: Funding will be supplied through the use of unexpended monies from the 2018 ETSB Award.</i>			
<b>Executive Summary:</b>			
<p>We are not currently in a position to offer final sign off and approval of our StarCom 21 system implementation in a project. Additionally, the Board has previously approved the expenditure of funds related to the exchange and upgrade of the remote microphones utilized by the fire agencies. Funding for this transaction will be provided through the use of remaining monies that were left over from the original 2018 ETSB award. This Change Order both codifies the mic exchange/upgrade as part of the project and extends the final acceptance date to July 16 of this year.</p>			
<b>Voting Requirements:</b>			
<i>This motion requires a simple majority vote.</i>			
<b>Attachments:</b> <i>(please list)</i>			
Proposed Change Order #6			
<b>Recommendation / Suggested Action:</b> <i>(briefly explain)</i>			
Staff requests approval of StarCom Change Order #6.			

**Change Order No.** 6  
**Date:** January 25, 2021  
**Project Name:** STARCOM21 Conversion Project  
**Customer Name:** TRI-COM Central Dispatch  
**Customer Project Mgr:** Joe Schelstreet

**The purpose of this Change Order is to:** *(highlight the key reasons for this Change Order)*

Exchange the shipped quantity 242 NNTN8575A Remote Speaker Microphones for 245 of the PMMN4106 XE500 High Impact Green, Chanel Knob, Extreme Temperature Cable Microphones.

Extend expected completion date: July 16, 2021

**Contract #** The Communications System and Services Agreement between Motorola Solutions, Inc. and Tri-Com Central Dispatch dated September 25, 2018  
**Contract Date:** September 25, 2018

In accordance with the terms and conditions of the contract identified above between TRI-COM Central Dispatch and Motorola Solutions, Inc., the following changes are approved:

**Contract Price Adjustments**

Original Contract Value:	\$3,830,383
Previous Change Order amounts for Change Order numbers 1 through 4	\$81,718
This Change Order:	\$24,598
New Contract Value:	\$3,936,699

**Completion Date Adjustments**

Original Completion Date:	August 31, 2019
Current Completion Date prior to this Change Order:	December 17, 2020
New Completion Date:	July 16, 2021

**Changes in Equipment:** *(additions, deletions or modifications)* **Include attachments if needed**

Exchange the shipped quantity 242 NNTN8575A Remote Speaker Microphones for 245 of the PMMN4106 XE500 High Impact Green, Chanel Knob, Extreme Temperature Cable Microphones.

**Changes in Services:** *(additions, deletions or modifications)* **Include attachments if needed**

Reprogram the TRICOM radios that were programmed for new audio settings in operation with the old speaker microphones. The radios will need to be reprogrammed to the original settings for operation with the new speaker microphones.

**Schedule Changes:** *(describe change or N/A)*

Extend expected completion date: July 16, 2021

**Pricing Changes:** *(describe change or N/A)*

Total contract increase of \$24,598 to \$3,936,699

**Customer Responsibilities:** *(describe change or N/A)*

Provide the shipped quantity 242 NNTN8575A Remote Speaker Microphones to be returned

**Payment Schedule for this Change Order:**

*(describe new payment terms applicable to this change order)*

100% of this Change Order will be invoiced upon acceptance of this change order. Due Net 30 days

Unless amended above, all other terms and conditions of the Contract shall remain in full force. If there are any inconsistencies between the provisions of this Change Order and the provisions of the Contract, the provisions of this Change Order will prevail.

IN WITNESS WHEREOF the parties have executed this Change Order as of the last date signed below.

**Motorola Solutions,  
Inc.**

**Customer**

By: Jennifer Klein

By: \_\_\_\_\_

Printed Name: Jennifer Klein

Printed Name: \_\_\_\_\_

Title: Field Resource Manager

Title: \_\_\_\_\_

Date: Jan 26, 2021

Date: \_\_\_\_\_

Reviewed by: Debra L Brown  
Motorola Solutions Project Manager

Date: \_\_\_\_\_





## **AGENDA ITEM EXECUTIVE SUMMARY**

Agenda Item:	Discussion of Electrical Work Procurement Process		
Presenter & Title:	Joe Schelstreet, Executive Director		
Date:	February 10, 2021		
<b><i>Please Check Appropriate Box:</i></b>			
<input type="checkbox"/>	Regular Meeting	x	Special Meeting _____
<input type="checkbox"/>	Other -		
Estimated Cost: N/A		Budgeted? N/A	<b>YES</b> <b>NO</b>
<i>If NO, please explain how the item will be funded: Funding will be supplied through the use of unexpended monies from the project construction contingency.</i>			
<b>Executive Summary:</b>			
<p>The beginning installation date for the new console furniture has been set for April 26. In order to facilitate the required electrical, radio and data connections a sizeable amount of preparation work needs to be completed below the false floor in the center. We have engaged FGM to provide us a plan for wiring, grounding and installation for this purpose. This has been completed and we are ready to provide the drawings for costing information. As we are uncertain as to the total cost of the project and are time limited due to the furniture delivery, staff would like the ability to obtain at least three quotes for the work instead of completing a full bidding process.</p>			
<b>Voting Requirements:</b>			
<i>None. Discussion only.</i>			
<b>Attachments: (please list)</b>			
N/A			
<b>Recommendation / Suggested Action: (briefly explain)</b>			
Staff requests feedback on the proposed electrical work procurement process			



**AGENDA ITEM EXECUTIVE SUMMARY**

Agenda Item:	Approval of Reef Contractors Change Order Request #4		
Presenter & Title:	Joe Schelstreet, Executive Director		
Date:	February 10, 2021		
<b><i>Please Check Appropriate Box:</i></b>			
<input type="checkbox"/>	Regular Meeting	x	Special Meeting _____
<input type="checkbox"/>	Other -		
Estimated Cost: \$9,470		Budgeted?	<b>YES X</b> <b>NO</b>
<i>If NO, please explain how the item will be funded: Funding will be supplied through the use of unexpended monies from the project construction contingency.</i>			
<b>Executive Summary:</b>			
<p>The end of the construction project is approaching and we are currently under budget by approximately \$50k. As the conditions of the loan require us to expend all of the funds on capital projects associated with the facility, we have contacted Reef Contractors in regards to the possibility of extending the tile work, baseboard and painting from the stairwell discharge area into the bathroom hallway. They have provided us the attached Change Order identifying the costs for this work. Completion of the project would provide a consistent tile for the entire basement and bring us closer to compliance with the requirements of the loan documents.</p>			
<b>Voting Requirements:</b>			
<i>This motion requires a simple majority vote.</i>			
<b>Attachments:</b> <i>(please list)</i>			
Proposed Change Order #4			
<b>Recommendation / Suggested Action:</b> <i>(briefly explain)</i>			
Staff requests approval of Reef Contractors Change Order #4.			



MBE/DBE General Contractors  
 1112 W Boughton Rd. #262  
 Bolingbrook, IL 60440  
 www.reefcontractors.us

**Change Order Request #4 (allowance use request)**

Project: Tricom Central Dispatch Seepage Remediation Project

Owner: TriCom Central Dispatch  
 Attn: Chief. Joe Schelstreet  
 Architect: FGM Architects (Mr. Ray Lee)  
 Date: 1/13/2020

Item	cost
1. Remove existing vinyl flooring and install additional 700 sq ft of luxury vinyl tile, includes rubber base board installation (same as in the training room)	\$6,800.00
2. Prime and one coat of paint of all areas with new flooring	\$2,340.00
3. Area to renovate (main basement area near elevator, two bathrooms, and stair area (flooring and baseboard only)). Excluded: any other rooms	
TOTAL	\$9,470.00

\*if proposed work is accepted please sign this proposal and email back to [ivette@reefcontractors.us](mailto:ivette@reefcontractors.us) at your earliest convenience.

Owner's representative: \_\_\_\_\_  
Name Date



**AGENDA ITEM EXECUTIVE SUMMARY**

Agenda Item:	Approval of IMEA Lighting Grant and Award of Contract to Von's Electric		
Presenter & Title:	Joe Schelstreet, Executive Director		
Date:	February 10, 2021		
<b><i>Please Check Appropriate Box:</i></b>			
<input type="checkbox"/>	Regular Meeting	x	Special Meeting _____
<input type="checkbox"/>	Other -		
Estimated Cost: \$24,800		Budgeted?	<b>YES</b> <b>NO X</b>
<i>If NO, please explain how the item will be funded: Funding will be supplied through the use of unexpended monies from the basement project loan.</i>			
<b>Executive Summary:</b>			
<p>Tri-Com has been working through a facility-wide lighting replacement project. The first phase, replacement of the lights in the Comm's Center itself, was completed in 2019. Additional work was done this year in the restrooms and administrative office area due to the failure of several fixtures. All work has been completed by Vons Electric. We are required to expend all funds from our loan on capital projects for the facility and it appears that we will be under budget at this time making funding available. Additionally, we were awarded an IMEA grant of just under \$2,000 for our lighting replacement project. Vons assisted with the grant application process. Changing out the remaining fixtures to LED's will also reduce our energy consumption by approximately 35,000 kWh annually. Thus saving money on the electric bill.</p>			
<b>Voting Requirements:</b>			
<i>This motion requires a simple majority vote.</i>			
<b>Attachments:</b> <i>(please list)</i>			
Approved grant request with project costs from Vons			
<b>Recommendation / Suggested Action:</b> <i>(briefly explain)</i>			
Staff requests approval of the IMEA Grant and the award of the project work to Von's Electric.			

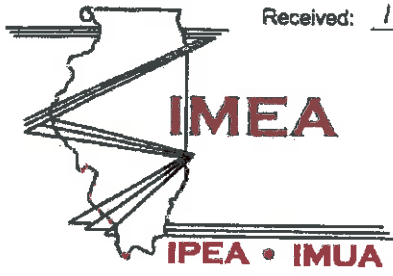

Received: 1/13/2021 Project # 96-St.Chules-15-2021  Pre-App  Final App

(Applicant: Please include this cover page, which IMEA will complete.)

Interior LED Lights  
Tri-Com Central Dispatch

# ILLINOIS MUNICIPAL ELECTRIC AGENCY (IMEA) ELECTRIC EFFICIENCY PROGRAM

## INCENTIVES FOR IMEA MEMBER COMMERCIAL / INDUSTRIAL and PUBLIC SECTOR ENTITIES

### Lighting Projects

(Interior and Exterior)

Revised October 15, 2020

Program Year FY 2020-21

Start Date: May 1, 2020

#### NOTE TO APPLICANTS ABOUT PROGRAM FUNDING AND PROJECT START DATES:

Cities have limited funding. You may want to contact the program administrator to check on funding availability before making a pre-application.

Projects that hope to receive an incentive should not begin until they have:

- a) submitted a pre-application;
- b) received a Notice to Proceed from the city and/or IMEA, and;
- c) had a pre-inspection (if required by the city).

#### Program Contact:

Redd Whelpley, Program & Communications Administrator  
Illinois Municipal Electric Agency  
3400 Conifer Drive  
Springfield, IL 62711  
Ph: 217-789-4632 or 800-243-4632  
FAX: 217-789-4642  
[rwhelpley@imea.org](mailto:rwhelpley@imea.org)

## IMEA Measure Savings Calculator: Lighting Retrofit Projects

Project Summary Information: 96\_StCharles\_15\_2021\_InteriorLEDs

### Project / Site General Information

Applicant Name: Tri-Com Central Dispatch  
 Customer Contact: Joe Schelstreet  
 Installation Address: 3823 Karl Madsen Dr.  
St. Charles, IL 60174

Building Type: Garage, 24/7 lighting Heating Fuel Type: Gas

### Total Savings

	Change in Connected Load (Watts Reduced)	Peak Demand Savings (kW)	Annual Energy Savings (kWh)
Lighting	3,978.95	3.9790	34,879.48
Controls	-	0.0000	0.00
Additional Projects*			
<b>Total</b>	<b>3,978.95</b>	<b>3.9790</b>	<b>34,879.48</b>

### Project Level Fixture and Sensor Participation Summary

Total Fixtures Installed

Total Wattage Controlled by Newly Installed Lighting Controls

### Total Rebate Summary

	Total Incentive
Fixture Rebates	\$ 1,989.48
Controls Rebates	\$ -
Additional Projects*	
<b>Total</b>	<b>\$ 1,989.48</b>

\*Additional Projects refers to any additional measures that may have been installed as part of the project as a whole, but whose savings/rebate were manually calculated outside of the Savings Calculator

# IMEA ELECTRIC EFFICIENCY PROGRAM PRE-APPLICATION CHECKLIST AND SUBMISSION REQUIREMENTS

A Complete Pre-Approval Application must include:

- This Completed Pre-Approval Application (found at <http://www.imea.org/EEProgram.aspx>).

**NOTE: ONLY INCLUDE RELEVANT PAGES OF THE APPLICATION.** This means only include the cover page and the pages on which you have written information concerning your project. (*Hint: The cover page and pages 3, 5, 6 and 14 will always be included. Likely only some of pages 8-13 will be included. Pages 15 and beyond will never be included.*)

- Signed Certification (page 6 of this application)
- A signed letter of assignment, if the incentive will go to any entity other than the local applicant or the national headquarters of the local applicant. *N/A*
- A separate project budget (not a simply single Total Project Cost figure reported on page 5, but an actual project budget) Note: a copy of a vendor bid may constitute a budget.
- Manufacturer spec sheets for new equipment. *It is very useful to highlight the pertinent Wattages on the spec sheets.*
- A copy of the applicant's electric bill.

## To Submit a Pre-Application

1. Gather materials listed above.
2. Put them into a single PDF file. No more than one application per e-mail.
3. E-mail application in a single PDF file to Rodd Whelpley at [rwhelpley@imea.org](mailto:rwhelpley@imea.org).

**NOTE: Applications comprised of multiple files delay processing and will very likely be returned to the applicant un-opened.**

**If you have questions, e-mail Rodd Whelpley or call 217-789-4632.**

**APPLICANT AND PROJECT INFORMATION**

Check one:  Pre-approval  Final Application

Name of Applicant - Company Name <u>Tri-Com Central Dispatch</u>	
Proposed Start Date: <u>April 1, 2001</u>	Planned Completion Date: <u>May 1, 2001</u>
Address where measures installed: <u>3823 Karl Madison Drive</u> ✓	
Address: <u>ST. CHARLES</u>	City: <u>ST. CHARLES</u>
Zip: <u>60171</u>	
Facility/Business Type: <u>911 Dispatch Center</u>	
Confirm this is a retrofit project: <input checked="" type="checkbox"/> yes <input type="checkbox"/> no (if no, then use a custom application)	
Heating Fuel Type (check one): <input checked="" type="checkbox"/> Gas <input type="checkbox"/> Electric Resistance <input type="checkbox"/> Heat pump <input type="checkbox"/> Unconditioned/Exterior	
Hours of Operation (list Opening and Closing Times): <u>24/7 - 365</u>	
Monday: <u>12-12</u>	Friday: <u>12-12</u>
Tuesday: <u>12-12</u>	Saturday: <u>12-12</u>
Wednesday: <u>12-12</u>	Sunday: <u>12-12</u>
Thursday: <u>12-12</u>	
Weeks per year of Operation: <u>52</u> Weeks	
Project Manager: <u>Joe SchelSTREET</u>	
Telephone #: <u>(630) 584-8169</u>	Fax #: <u>(630) 262 1911</u>
Email Address: <u>JSchelSTREET@Tri-Com911.org</u>	
IMEA Electric Efficiency Incentive Requested <u>\$ <del>2,397.00</del> \$1,989.48</u> (Calculated in the Application - See Pages 8 - 14. The amount on the line above is the total amount on Table 7, page 14)	Contractor Information (if known)
Other Incentive Funds \$ _____	Contact Name: <u>Denver Dawson</u>
Specify Source of Other Incentive Funds	Company: <u>Vons Electric</u>
Total Project Cost <u>\$ 24,800</u> ✓	Phone: <u>(630) 377 8667</u>
	Email Address: <u>denver@vonselectric.com</u>



## APPLICANT CERTIFICATIONS

NOTE: If this project is approved and completed, then IMEA will send an Automated Clearing House (ACH) Payment Authorization Form to the applicant listed on this page. The incentive will be deposited into the account specified on the ACH form.

IF THE REBATE INCENTIVE SHOULD GO TO ANY ENTITY OTHER THAN THE LOCAL APPLICANT OR ITS NATIONAL HEADQUARTERS, then you must include a signed letter of assignment. In that case, upon completion of the project, the designated payee will file the ACH form and receive the incentive.

### Applicant hereby certifies and understands that:

- The project site receives wholesale electric service from IMEA or electric delivery service from an IMEA member municipal electric system.
- All authorizations required to perform the project described in this application have either been obtained or will be obtained no later than 90 days following the project beginning date set forth in the Notice to Proceed Letter issued by the IMEA.
- It has not been barred from contracting with a unit of state or local government as a result of a violation of Section 33E-3 or 33E-4 of the Criminal Code of 1961 (720 ILCS 5/33 E-3 and 5/33 E-4).
- The Illinois Prevailing Wage Act (820 ILCS 130/0.01) may apply and that Grantees are responsible for determining if their projects will trigger compliance.
- As of the submittal date, the information provided in its application is accurate, and the individuals signing below are authorized to submit this application.
- Replaced equipment will be disposed of – not placed in storage.
- The applicant, by accepting an incentive for this electric efficiency project, acknowledges and agrees that any rights or abilities arising from kW savings that result from the execution of this project and that may be bid or sold into a Regional Transmission Operator market as energy efficiency or demand response or otherwise shall belong solely to IMEA.

Joe Schelstreet  
Authorized Official (signature\*)

Joe Schelstreet  
Typed/Printed Name

Executive Director  
Title

3823 Karl Madsen Drive  
Authorized Signature Address

St. Charles 60175-7548  
Authorized Signature City, Zip (find 9-Digit Zip at <http://zip4.usps.com/zip4/welcome.jsp>)

Jschelstreet@TNI-com 911.org  
Authorized Signature E-mail Address

(630) 584-8169  
Telephone

(630) 262-1911  
Fax

1/12/2021  
Date

\* Please supply Certifications (this page) with original signature via mail, fax or electronically (scanned document)

**Table 2: Measure = Replace Existing Lights with LED Fixtures – Including Exterior**

NOTE: You may copy this page and use it as many times as you need

**Wattage Saved**

(1) Baseline Equipment <small>Write a description of the type of lamps, length of lamps, number of lamps per fixture, and ballast type.</small>	(2) Quantity of Old Fixtures	(3) Watts of Each old Fixture*	(4) Type of New Equipment to be installed <small>Write a description of the type of lamps, length of lamps, number of lamps per fixture, and ballast type.</small>	(5) Quantity of New Fixtures to be Installed	(6) Watts of Each New Fixture	(7) New Occ Sensor Installed (Y/N) <small>NOTE: Only Sensors on interior lights are eligible for incentives</small>	(8) Total Watts Saved = [(2)x(3)] - [(5)x(6)]	Interior (write "I") Or Exterior (write "E") Lights	Exterior Lights Are (check one)
Ballast: 18 32watt 4ft 3-bulbs electronic	58	88 OK	22x4 Flat Panel LED with Colorchanging	58	38.9 <del>39</del>	Ø	<del>2842</del> 2,847.8		<input type="checkbox"/> Dusk to dawn. <input type="checkbox"/> Off at close of business
Electronic Ballast: 18 32watt 4ft 3-bulb	30	88 OK	LED magnetic Tape existing housing to remain.	30	60 <sup>OK</sup>	Ø	840	✓	<input type="checkbox"/> Dusk to dawn. <input type="checkbox"/> Off at close of business
Electronic Ballast: 18 32watt 3ft 3-bulb	9	69 OK	New LED 4ft 6 linear Fixture	9	36.65 <del>36</del>	Ø	<del>297</del>		<input type="checkbox"/> Dusk to dawn. <input type="checkbox"/> Off at close of business
								291.15	<input type="checkbox"/> Dusk to dawn. <input type="checkbox"/> Off at close of business
									<input type="checkbox"/> Dusk to dawn. <input type="checkbox"/> Off at close of business
									<input type="checkbox"/> Dusk to dawn. <input type="checkbox"/> Off at close of business
<b>Sub Total - Wattage Saved</b>								<b>3979</b>	

\*To record Wattages of your existing equipment, see page 7 of this application, "Guide to Wattages of your Existing Equipment" or Appendix A or B of this application. Note: IMEA does not incentivize CFL replacement or de-lamping without replacing existing lighting.

**Eligible Incentive**

(1) Equipment Type	(2) Incentive per Unit - \$0.50/Watt Reduced and Watts Controlled at \$0.12	(3) Watts Reduced - From Worksheet Above and/or Wattage of the NEW Interior Lights controlled by Sensors	(4) Eligible Incentive (2) X (3)
Interior or Exterior LED Fixtures	.50	<del>3979</del>	<del>1989.50</del>
Occupancy Sensors	\$0.12		
<b>Total Eligible Incentive of this Measure - to Table 7 (page 14)</b>			<b>1989.50</b>

3,978.95

**Table 7: TOTAL ELEGIBLE INCENTIVE FOR THIS APPLICATION**

**Note:** Applicants bring incentives calculated on the tables on pages 8-13 to calculate a total eligible incentive amount on this table.

Measure	Eligible Incentive As Calculated Above
T8 Fixtures (from page 8)	
LED Fixtures (from page 9)	<del>\$1,989.50</del>
LED Exit Signs Installed (from page 10)	
T5 Fixtures (from page 11)	
Occupancy Sensors (from page 12)	
Custom Lighting Project (from page 13)	
<b>Total Eligible Incentive for this Application (to page 5)</b>	<del>\$1,989.50</del>

\$1,989.48

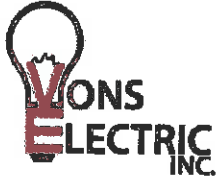

**Vons Electric, Inc.**  
 2701 Dukane Drive  
 St Charles, IL 60174

# Proposal

Date	Estimate #
12/30/2020	6219
<b>Pricing valid for 30 days from the date of this proposal</b>	

Phone #	630.377.VONS (8667)
---------	---------------------

Client Name / Address
Tri-Com Central Dispatch 3823 Karl Madsen Dr St.Charles IL 60175

Project Number
20-1912E

Description of Work	Qty	Cost	Total
<b>Basement Men's Bathroom</b> 1-2x4 fixture Retrofit 1 existing 4ft fixture			
<b>Basement Women's Bathroom</b> 1-2x4 fixture Retrofit 1 existing 4ft fixture			
<b>Training Room</b> 18-new 2x4 fixtures Rewire fixtures to be 6 front on one switch and the back 12 on another switch			
<b>Training Room Pump Closet</b> Retrofit 2 existing 4ft fixtures			
<b>Training Room Back Two Closets</b> 2-new 3ft / LED / linear fixtures			
<b>Back Hallway</b> 4-2x4 fixtures			
<b>Pump Room East</b> 2-2x4 fixtures			
<b>East Storage Room (Old Generator)</b> Retrofit 2 existing 4ft fixtures			
Thank you for the opportunity to do business!	<b>Total</b>		

Client Signature: \_\_\_\_\_

Date of Acceptance: \_\_\_\_\_



**WWW.VONSELECTRIC.COM**  
**LICENSED, INSURED & BONDED**

**KOHLER.**  
**Generators** Certified Installer

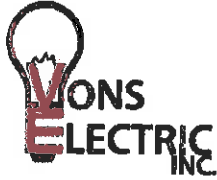

Vons Electric, Inc.  
2701 Dukane Drive  
St Charles, IL 60174

# Proposal

Date	Estimate #
12/30/2020	6219

Phone #	630 377 VONS (8667)
---------	---------------------

**Pricing valid for 30 days from the date of this proposal**

Client Name / Address
Tri-Corn Central Dispatch 3823 Karl Madsen Dr St. Charles IL 60175

Project Number
20-1912E

Description of Work	Qty	Cost	Total
Electrical Room Retrofit 3 existing 4ft fixtures			
Equipment Room (Radio Room) Retrofit 3 existing 4ft fixtures			
File Storage Room Retrofit 10 existing 4ft fixtures			
Sprinkler Room Retrofit 3 existing 4ft fixtures			
-Our proposal will be adjusted if the authority having jurisdiction makes changes			
Excludes: City permit fees and charges Drywall patching and painting Replacing broken lenses if required			

Thank you for the opportunity to do business!	<b>Total</b>	\$24,800.00
---	--------------	-------------

I, the undersigned, hereby authorize the Work described on this Proposal. I have read and agree to this Proposal, including the attached terms and conditions. I recognize that there may be other service providers who may be able to perform this work and understand that I have the option of seeking other bids before authorizing this work. I represent that I am either the owner or owner's agent, and have authority to authorize the Work, and agree to pay for all services, including goods and services, received. I further, agree to pay Vons Electric, Inc. all costs and expenses, including but not limited to collection expenses, court costs and reasonable attorney's fees incurred by Vons Electric, Inc. in seeking to enforce any of the liabilities or obligations of the undersigned under this Agreement. Estimated Start/End Date: TBD upon acceptance of this proposal

Client Signature: \_\_\_\_\_

Date of Acceptance: \_\_\_\_\_



**WWW.VONSELECTRIC.COM**  
**LICENSED, INSURED & BONDED**

**KOHLER.** Certified  
Generators Installer



## FEATURES & SPECIFICATIONS

**INTENDED USE** — Available in several color temperatures, lumen packages and lengths. Ideal for use in commercial, retail, office, warehouse and display applications. **Certain airborne contaminants can diminish integrity of acrylic and/or polycarbonate.** [Click here for Acrylic/Polycarbonate Compatibility table for suitable uses.](#)

Certain airborne contaminants may adversely affect the functioning of LEDs and other electronic components, depending on various factors such as concentrations of the contaminants, ventilation, and temperature at the end-user location. [Click here for a list of substances that may not be suitable for installation with LEDs and other electronic components.](#)

**CONSTRUCTION** — Compact-design channel and cover are formed from code compliant, 22 gauge cold-rolled steel.

**SENSOR SWITCH JUST ONE TOUCH TECHNOLOGY** — Single room control wireless technology available for easy install and commissioning to aid in code compliance. The JOT option enables the fixture with Just One Touch pairing capability. The JOTVTK15 option features a luminaire-embedded occupancy and ambient light sensor allows the luminaire to power off when the space is unoccupied or when enough ambient light is entering the space.

**FINISH** — High-gloss, baked white enamel (standard).

**OPTICS** — LEDs provide 80+ color rendering index (CRI) at 3500K, 4000K and 5000K. Diffuse acrylic lens with ultra-sonically welded end caps provides smooth, linear illumination.

**ELECTRICAL** — Luminaire Surge Protection Level: Designed to withstand up to 2.5kV/0.75kA per ANSI C82.77-5-2015. For applications requiring higher level of protection additional surge protection must be provided.

Driver is standard 0-10V dimming class 2.

**INSTALLATION** — Fixture may be surface or suspension mounted with appropriate mounting options (see accessories). Easy to install row aligner bracket included for continuous row mounting.

**LISTINGS** — CSA certified to US and Canadian safety standards and listed suitable for damp locations. Minimum starting temperature of -40°F (-40°C). Maximum ambient operating temperature of 95°F (35°C). See notes for controls temperature restrictions.

DesignLights Consortium® (DLC) qualified product. Not all versions of this product may be DLC qualified. Please check the DLC Qualified Products List at [www.designlights.org/QPL](http://www.designlights.org/QPL) to confirm which versions are qualified.

**WARRANTY** — 5-year limited warranty. Complete warranty terms located at: [www.acuitybrands.com/support/customer-support/terms-and-conditions](http://www.acuitybrands.com/support/customer-support/terms-and-conditions)

**Note:** Actual performance may differ as a result of end-user environment and application. All values are design or typical values, measured under laboratory conditions at 25 °C. Specifications subject to change without notice.

Catalog Number
Notes
Type

LED Strip Light

CSS



### CSA+ Capable Luminaire

This item is an A+ capable luminaire, which has been designed and tested to provide consistent color appearance and out-of-the-box control compatibility with simple commissioning.

- All configurations of this luminaire meet the Acuity Brands' specification for chromatic consistency
- This luminaire is part of an A+ Certified solution for nLight® or XPoint™ Wireless control networks marked by a shaded background\*

To learn more about A+, visit [www.acuitybrands.com/aplus](http://www.acuitybrands.com/aplus)

\*See ordering tree for details



Catalog Number
Notes
Type

Contractor Select™  
**CPX™**  
 LED Panel

CPX™ from Lithonia lighting is the perfect choice for a quality LED panel at an affordable price. The smooth, even lens projects a crisp and clean aesthetic. CPX is the perfect choice for budget-conscious school, commercial office, or small retail footprint projects.

**FEATURES:**

- Industry standard wattages
- Long-life LEDs maintain greater than 70% of their lumen output at 50,000 hours
- 0-10V dimming driver, dims to 10%

**WEIGHT:**

**2x2**  
 Unit: 6.39lbs  
 Unit Carton: 7.72lbs  
 Master Carton: 30.42lbs  
**2x4**  
 Unit: 11.02lbs  
 Unit Carton: 13.89lbs  
 Master Carton: 27.78lbs



Switchable Lumens



Catalog Number	UPC	Description	Lumens	Input Watts	CCT	CRI	Voltage	Pallet qty.
CPX 2X2 3200LM 35K M4	191848338537	2x2 LED Panel	3555	31.5	3500K	80	120-277V	40
CPX 2X2 3200LM 40K M4	191848338650	2x2 LED Panel	3659	31.5	4000K	80	120-277V	40
CPX 2X2 3200LM 50K M4	193048313642	2x2 LED Panel	3737	31.5	5000K	80	120-277V	40
CPX 2X4 4000LM 35K M2	191848338490	2x4 LED Panel	4543	38.9	3500K	80	120-277V	20
CPX 2X4 4000LM 40K M2	191848338506	2x4 LED Panel	4692	38.9	4000K	80	120-277V	20
CPX 2X4 4000LM 50K M2	193048313680	2x4 LED Panel	4766	38.9	5000K	80	120-277V	20
CPX 2X2 AL07 SWW7 M4	193048542806	2X2 Switchable Panel	See Switchable Table	See Switchable Table	3500K/4000K/5000K	>80	120-277V	40
CPX 2X4 AL08 SWW7 M2	193048542844	2X4 Switchable Panel	See Switchable Table	See Switchable Table	3500K/4000K/5000K	>80	120-277V	20

**NOTES**

1. PS1055CP remote mounted only. See Power Sentry PS 1055CP, PS1055CP-P, PS1055CP-P2, PS1055CP-P3, PS1055CP-P4, PS1055CP-P5, PS1055CP-P6, PS1055CP-P7, PS1055CP-P8, PS1055CP-P9, PS1055CP-P10, PS1055CP-P11, PS1055CP-P12, PS1055CP-P13, PS1055CP-P14, PS1055CP-P15, PS1055CP-P16, PS1055CP-P17, PS1055CP-P18, PS1055CP-P19, PS1055CP-P20, PS1055CP-P21, PS1055CP-P22, PS1055CP-P23, PS1055CP-P24, PS1055CP-P25, PS1055CP-P26, PS1055CP-P27, PS1055CP-P28, PS1055CP-P29, PS1055CP-P30, PS1055CP-P31, PS1055CP-P32, PS1055CP-P33, PS1055CP-P34, PS1055CP-P35, PS1055CP-P36, PS1055CP-P37, PS1055CP-P38, PS1055CP-P39, PS1055CP-P40, PS1055CP-P41, PS1055CP-P42, PS1055CP-P43, PS1055CP-P44, PS1055CP-P45, PS1055CP-P46, PS1055CP-P47, PS1055CP-P48, PS1055CP-P49, PS1055CP-P50, PS1055CP-P51, PS1055CP-P52, PS1055CP-P53, PS1055CP-P54, PS1055CP-P55, PS1055CP-P56, PS1055CP-P57, PS1055CP-P58, PS1055CP-P59, PS1055CP-P60, PS1055CP-P61, PS1055CP-P62, PS1055CP-P63, PS1055CP-P64, PS1055CP-P65, PS1055CP-P66, PS1055CP-P67, PS1055CP-P68, PS1055CP-P69, PS1055CP-P70, PS1055CP-P71, PS1055CP-P72, PS1055CP-P73, PS1055CP-P74, PS1055CP-P75, PS1055CP-P76, PS1055CP-P77, PS1055CP-P78, PS1055CP-P79, PS1055CP-P80, PS1055CP-P81, PS1055CP-P82, PS1055CP-P83, PS1055CP-P84, PS1055CP-P85, PS1055CP-P86, PS1055CP-P87, PS1055CP-P88, PS1055CP-P89, PS1055CP-P90, PS1055CP-P91, PS1055CP-P92, PS1055CP-P93, PS1055CP-P94, PS1055CP-P95, PS1055CP-P96, PS1055CP-P97, PS1055CP-P98, PS1055CP-P99, PS1055CP-P100.



**Maverick**  
**Energy Solutions**  
 Lighting Controls. Solar

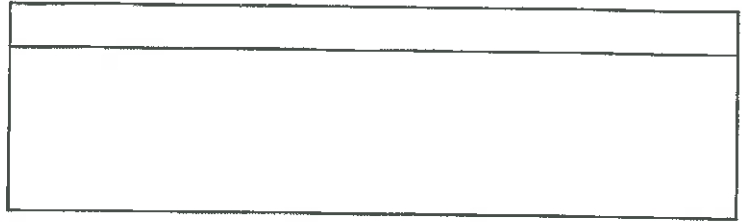

**LED RETROFIT KIT STRIPS 24W (1 Strip), 30W (2 Strip), 40W (2 Strip), 45W (3 Strip), 60W (4 Strip) SPEC**

**Features:**

- Easy to install and operate
- Energy saving, long lifespan
- Light is soft and uniform, safe to eyes
- Green and eco-friendly without mercury

**Applications:**

- Factory floor, supermarkets, and warehouse

SPECIFICATIONS:	
WATTAGE	24W, 30W, 40W, 45W, 60W
MODEL #	MES-RTST124, MES-RTST230, , MES-RTST240, MES-RTST345, MES-RTST460
CERTIFICATIONS	UL DLC
VOLTAGE	AC100-277V
POWER FACTOR	0.8
FREQUENCY	50/60Hz
LUMENS	3,120, 3,900, 5,200, 5,850, 7,800
LUMENS EFFICIENCY	130 LM/W
KELVIN (CCT)	3000, 4000, 5000
CRI	>80
IP RATING	IP44
LENS	Clear, Frosted
MATERIALS	AL + PC
POWER	External UL Driver
LED CHIPS	SMD2835
LIFE SPAN (HOURS)	50,000
DIMMING OPTION AVAILABLE	Yes
LENGTH OF WARRANTY (YEARS)	5
PRODUCT LENGTH	4FT
MOUNTING	Magnets, Surface Mount
WORKING ENVIROMENT	-20°C TO 45°C(-30°C TO 80°C)
SUGGESTED REPLACEMENT FOR	1x4, 2x4, 1x8, 2x8
POWER EFFICIENCY	>90%



5001 Spring Valley Road  
 Dallas, TX 75244  
 Phone: (214) 571-6374, Fax: (214) 571-6285  
 www.maverickled.com  
 Sales@maverickled.com



# CSS LED Strip Light



Looking for Contractor Select ready available configurations? Click here to visit Contractor Select™ spec sheet or go to [www.contractorselect.com](http://www.contractorselect.com)

## ORDERING INFORMATION

Lead times will vary depending on options selected. Consult with your sales representative.

Example: CSS L96 AL04 MVOLT SWW3 80CRI

Series	Length	Lumen Output	Voltage	Color temperature	Color rendering index	Options
CSS Contractor Single Strip LED	L48 48"	4000LM 4000 Lumens † AL03 Switchable lumens, 3000LM / 4000LM / 5000LM	MVOLT 120-277V 347 347V †	35K 3500K † 40K 4000K † 50K 5000K † SWW3 Switchable white, 35K / 40K / 50K	80CRI 80 CRI	<b>JOT Enabled Wireless Controls:</b> † <b>JOT</b> Wireless room control with "Just One Touch" pairing <b>JOTVTR1S</b> Wireless occupancy sensor with "Just One Touch" pairing <b>Individual Controls:</b> <b>SFR30CSS</b> Factory installed 360°, large motion, high bay sensor, SFR 30 † <b>SFR7CSS</b> Factory installed 360°, small motion, low bay sensor, SFR 7 † <b>Wire Guard:</b> <b>WG</b> Wire Guard
	L96 96"	8000LM 8000 Lumens † AL04 Switchable lumens, 6000LM / 8000LM / 10000LM				

NOTE: † indicates option chosen has ordering restrictions. Please reference ordering restrictions chart.

Accessories: Order as separate catalog number.	
HC36 M12	Chain hanger and jack chain, 36" (one pair)
ZACVH	Aircraft cable 10' (one pair)
SQ	5/8" Swivel-stem hanger (specify length in 2" increments up to 48")
rPP20D	nLight® air dimming/switching module
SFR30CSS	Field installed 360°, large motion, high bay sensor, <a href="#">SFR 30</a> †
SFR7CSS	Field installed 360°, small motion, low bay sensor, <a href="#">SFR 7</a> †
Y J10	Y hanger in multiples of 10 (five pair)
WGCSS	Wire Guard with Mounting hardware (one 4ft)
MNLKJBOXCVR M12	Junction box cover and hardware, white

† Option Value Ordering Restrictions	
Option value	Restriction
35K, 40K, 50K	Not available with AL0 lumen packages.
4000LM, 8000LM	Not available with SWW3.
JOT Enabled Controls	Not available with AL03, AL04, 347V or SWW3. Not intended for continuous row mount applications. Minimum starting temp of 14°F (-10°C). Maximum operating temp of L48 at 95°F (35°C) & L96 at 86°F (30°C).
SFR Sensors	Not available with 347V. Can only be mounted at the end of continuous row mount applications. On/off function only. Minimum starting temp of 14°F (-10°C).
Wire Guard	Does not cover Controls.

# CSS LED Strip Light

## OPERATIONAL DATA

Length	Nominal Lumen Package	Color Temperature	Delivered Lumens	Wattage	Lumens/Watt
L48	4000 LM	4000K	4,298	35.3	121.8
		3500K	3,190	27.7	115.4
	AL03 (3000 LM)	4000K	3,247	27.7	117.4
		5000K	3,250	27.7	117.5
		3500K	4,135	35.8	115.4
	AL03 (4000 LM)	4000K	4,206	35.8	117.3
		5000K	4,258	35.8	119
		3500K	5,058	43.9	115.1
	AL03 (5000 LM)	4000K	5,150	43.9	117.2
		5000K	5,274	43.9	120.1
		3500K	8,596	72	119.3
	L96	8000 LM	4000K	8,596	72
3500K			6,380	55.3	115.4
AL04 (6000 LM)		4000K	6,495	55.3	117.4
		5000K	6,591	55.3	117.5
		3500K	8,271	71.7	115.4
AL04 (8000 LM)		4000K	8,413	71.7	117.3
		5000K	8,535	71.7	119
		3500K	10,115	87.9	115.1
AL04 (10000 LM)		4000K	10,300	87.9	117.2
		5000K	10,549	87.9	120.1
		3500K	10,115	87.9	115.1

PROJECTED LUMEN MAINTENANCE			
Lumen Maintenance Factor	0.91	0.81	0.75
Operating Hours	40,000	90,000	120,000

\*Actual performance may vary based on ambient temperature of installed location.

\*All values are typical and are at 25C. Actual performance may vary and is dependent on operating environment.

## DIMENSIONS

All dimensions are shown in inches unless otherwise noted.

Length	Width	Height	Approximate weight	Fixtures per pallet	Pallet Dimensions
L48	2.62	2.22	5 lbs	98	46 x 57
L96	2.62	2.22	10 lbs	102	46 x 98.5

\*Weights will vary slightly with added options.

## 4FT Assembly

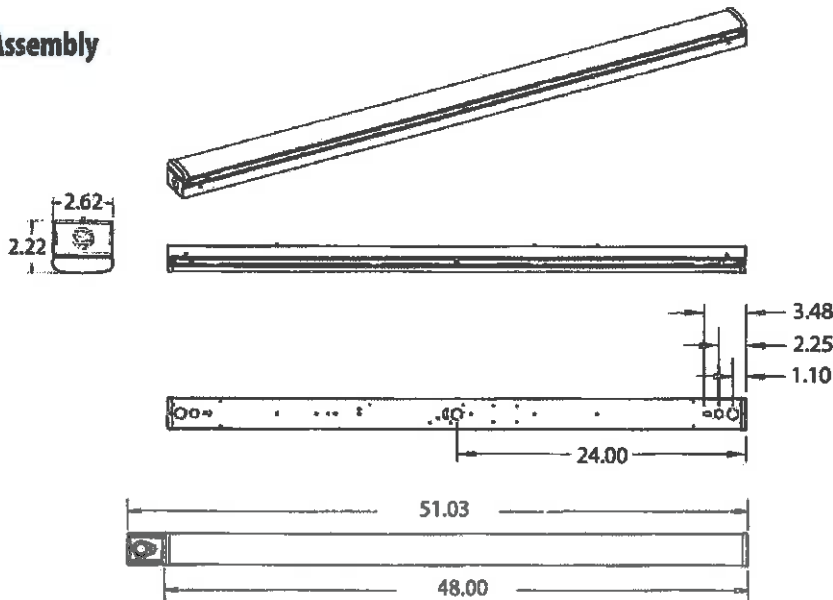

# CSS LED Strip Light

## DIMENSIONS

All dimensions are shown in inches (centimeters) unless otherwise noted.

### 8FT Assembly

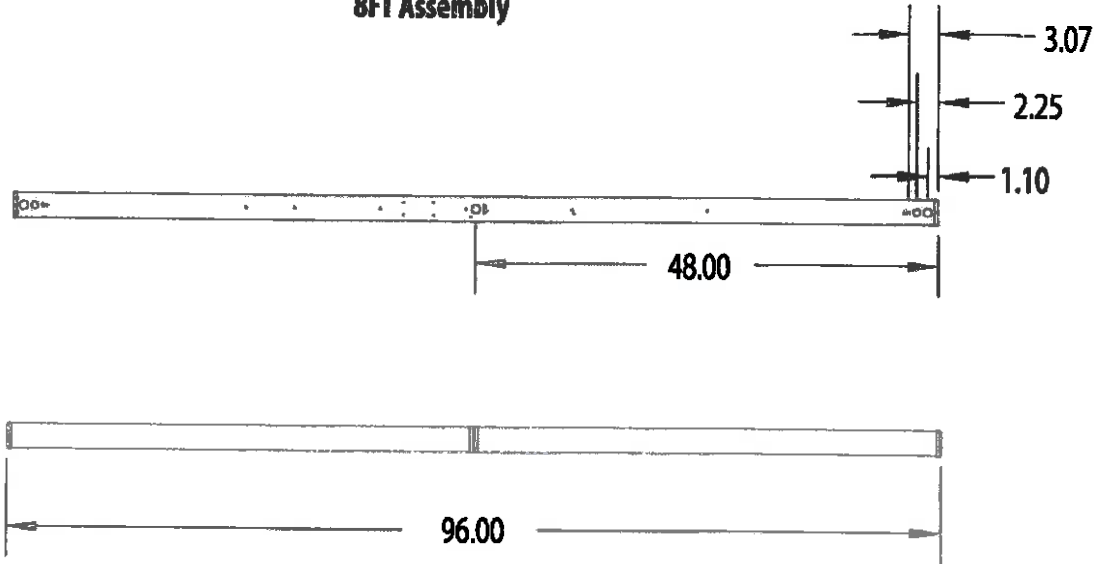

## INDIVIDUAL CONTROLS COVERAGE PATTERNS

### SFR 30 UNIVERSAL 360° LENS

- Provides excellent detection of large motion (e.g. walking) when mounted between 15 to 40 ft (4.57 to 12.19 m)
- 15 to 20 ft (4.57 to 6.10 m) radial coverage overlaps area lit by a typical high bay fixture
- Recommended for fixtures that have a 1:1 spacing to mounting height ratio or less (e.g. fixtures 30' on center or less @ a 30' mounting height).

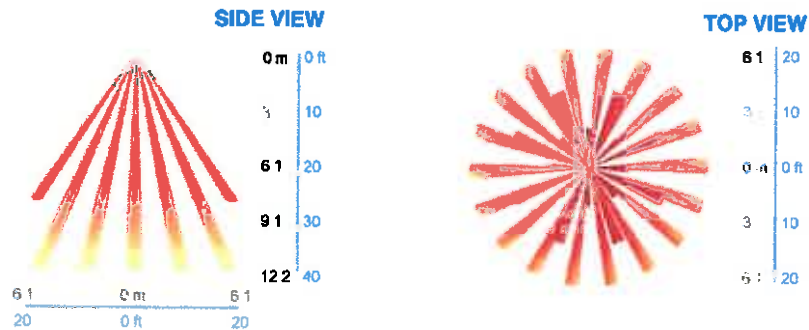

# CSS LED Strip Light

## SFR 7 MINI LOW BAY 360° LENS

- Recommended for walking motion detection from mounting heights between 8 ft (2.44 m) and 20 ft (6.10 m)
- Initial detection of walking motion along sensor axes at distances of 2x the mounting height up to 15 ft (4.57 m) and 1.75x up to 20 ft (6.10 m).
- Provides 12 ft (3.66 m) radial detection of small motion when mounted at 9 ft (2.74 m)
- Initial detection will occur earlier when walking across sensor's field of view than when walking directly at sensor

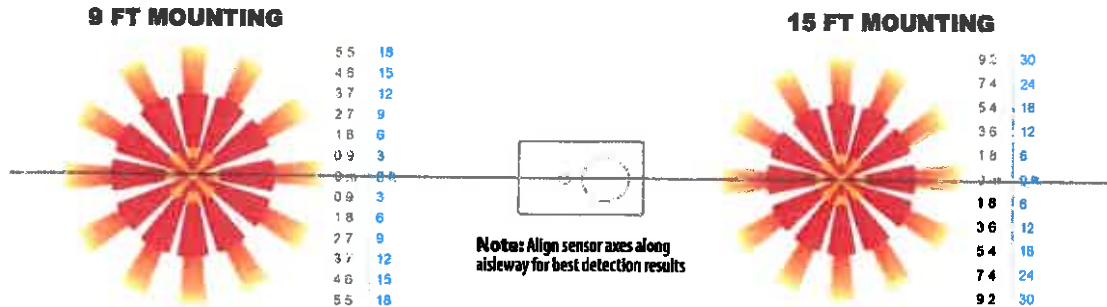

## MAXIMUM # OF FIXTURES PER SFR SENSOR

Nomenclature	Maximum # of Fixtures per SFR SENSOR
CSS L48 4000LM MVOLT	20
CSS L48 ALD3 MVOLT	16
CSS L96 8000LM MVOLT	10
CSS L96 ALD4 MVOLT	8

## JOT ENABLED WIRELESS CONTROLS

### TYPICAL SMALL ROOM APPLICATION (UP TO 250 SQ. FT.)



**One Entryway**  
1x WSXA JOT  
2x JOT Enabled Fixture

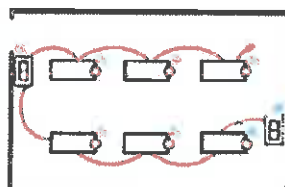

**Two Entryways**  
2x SPODMRA JOT  
6x JOT Enabled Fixture with Occupancy Sensor

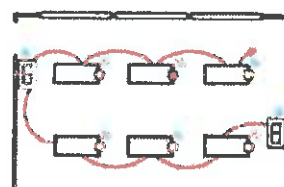

**Two Entryways with Daylight Harvesting**  
2x SPODMRA JOT  
1x JOT Enabled Fixture with Photocell and Occupancy Sensor  
3x JOT Enabled Fixture with Occupancy Sensor

## JOT ENABLED PRODUCT PORTFOLIO

### CONTROLS



## PHOTOMETRICS

Please see [www.lithonia.com](http://www.lithonia.com).



Patent Pending

LITHONIA-CSS-STRIP-LED



Accessories: Order as separate catalog number:

PS10SSCP	10W constant power <sup>1</sup>
DGA22	Drywall grid adapter for 2x2 recessed fixture.
DGA24	Drywall grid adapter for 2x4 recessed fixture.
2X2SMKSH	Multi-Use Surface Mount Kit 2x2, Shallow Depth
2X4SMKSH	Multi-Use Surface Mount Kit 2x4, Shallow Depth
2X2SMKSH PAF	Multi-Use Surface Mount Kit 2X2 Post-Paint
2X4SMKSH PAF	Multi-Use Surface Mount Kit 2X4 Post-Paint
PAC 2DNF 36	Panel Air Craft Kit, 2 cables with Y splitter, No Power Feed, 36 Inches. Recommended for 1X4 or 2X2 Panel Fixtures only.
PAC 2DF 36	Panel Air Craft Kit, 2 cables with Y splitter, with Power Feed, 36 inches. Recommended for 1X4 or 2X2 Panel Fixtures only.
PAC 4DNF 36	Panel Air Craft Kit, 4 cables, No Power Feed, 36 inches. Recommended for 2X4, 1X4 or 2X2 Panel Fixtures
PAC 4DF 36	Panel Air Craft Kit, 4 cables, with Power Feed, 36 inches. Recommended for 2X4, 1X4 or 2X2 Panel Fixtures
PAC 2DNF 72	Panel Air Craft Kit, 2 cables with Y splitter, No Power Feed 72 inches. Recommended for 1X4 or 2X2 Panel Fixtures only.
PAC 2DF 72	Panel Air Craft Kit, 2 cables with Y splitter, with Power Feed, 72 inches. Recommended for 1X4 or 2X2 Panel Fixtures only.
PAC 4DNF 72	Panel Air Craft Kit, 4 cables, No Power Feed, 72 inches. Recommended for 2X4, 1X4 or 2X2 Panel Fixtures.
PAC 4DF 72	Panel Air Craft Kit, 4 cables, with Power Feed, 72 inches. Recommended for 2X4, 1X4 or 2X2 Panel Fixtures

Switchable Table						
Size (ft)	Home/Store	Lumen Package	CCT	Lumen	Wattage	Efficiency
2x2	CPX 2X2 AL07 SWW7 M4	Low Lumen	3500K	2399	19.1	125.6
			4000K	2570	18.5	138.9
			5000K	2456	19.1	128.6
		Med Lumen	3500K	3356	28.7	116.9
			4000K	3649	27.5	132.7
			5000K	3427	28.5	120.2
		High Lumen	3500K	4131	37.5	110.2
			4000K	4564	35.8	127.5
			5000K	4212	37.3	112.9
2x4	CPX 2X4 AL08 SWW7 M2	Low Lumen	3500K	3813	28.94	131.8
			4000K	4033	28.1	143.5
			5000K	3938	28.86	136.5
		Med Lumen	3500K	4677	36.8	127.1
			4000K	5009	35.55	140.9
			5000K	4834	36.65	131.9
		High Lumen	3500K	6048	50.56	119.6
			4000K	6563	48.53	135.2
			5000K	6241	50.24	124.2



## Specifications

### INTENDED USE:

CPX is a low-glare panel featuring an external driver. This cost-effective, reliable panel is visually comfortable and can be recessed mounted. Suitable for many applications such as schools, offices, retail, convenience stores and other commercial spaces. **Certain airborne contaminants can diminish integrity of acrylic. [Click here for Acrylic Environmental Compatibility table for suitable uses.](#)** Adjustable Lumen (AL07, ALO8) and Switchable White (SWW7) configurations available. U.S. Patent No. 10,681,784.

### CONSTRUCTION:

The extruded aluminum frame with satin white lens provides excellent shielding and uniform luminance. The low-profile design of CPX provides increased installation flexibility especially in restricted plenum spaces. The backplate includes integral T-bar clips for installation into T-grid ceilings.

### ELECTRICAL:

Long-life LEDs, coupled with a high-efficiency driver, provide superior illumination for extended service life. Greater than 70% LED lumen maintenance at 50,000 hours (L70>50,000) 0-10V dimming driver, dims to 10% and contains non-isolated dimming leads.

### LISTINGS:

CSA certified to meet US and Canadian standards. Damp location listed IC rated. DesignLights Consortium® (DLC) qualified product. Not all versions of this product may be DLC qualified. Please check the DLC Qualified Products List at [www.designlights.org/DPL](http://www.designlights.org/DPL) to confirm which versions are qualified.

### WARRANTY:

5-year limited warranty. Complete warranty terms located at: [www.acuitybrands.com/equipment/customer-support/terms-and-conditions](http://www.acuitybrands.com/equipment/customer-support/terms-and-conditions)

**Note:** Actual performance may differ as a result of end-user environment and application. All values are design or typical values, measured under laboratory conditions at 25 °C. Specifications subject to change without notice.

## Dimensions

2'x2'

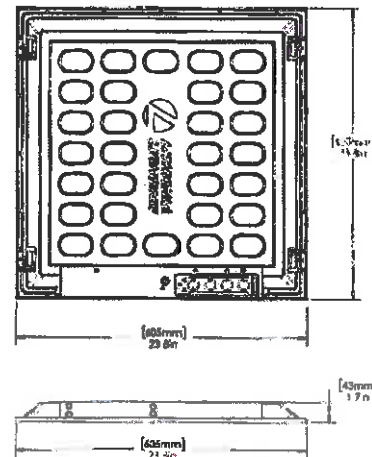

2'x4'

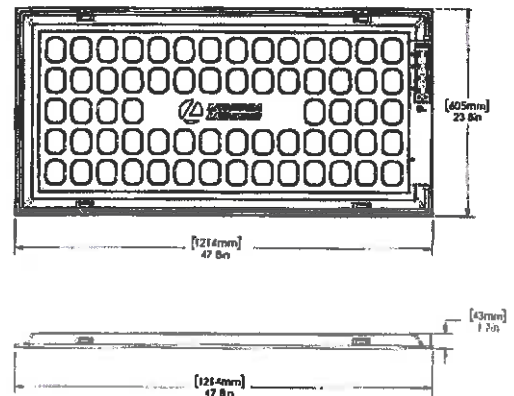

All dimensions are inches (millimeters) unless otherwise indicated



ST. CHARLES  
SINCE 1814

**City of St. Charles**

Utility Billing 630-377-4426  
Pay by Phone 844-443-9794  
Electrical Outage 866-444-0016  
Water/Sewer (after hours) 630-443-3661

<http://www.stcharlesil.gov>

2 E Main Street  
St. Charles IL 60174-1984

**Office Hours**  
Monday - Friday  
8 am - 4:30 pm

**Service Period**  
10/28/20 to 12/01/20

**Customer(s) Name(s)**  
TRI COM CENTRAL DISPATCH

**Service Address**  
3823 KARL MADSEN DR

**Account Number** 4-54-90835-1-0-040910  
**Due Date** 12/31/2020

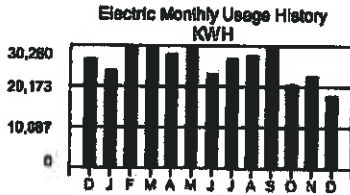

**Previous Reading** 28294  
**Current Reading** 28519  
**Consumption** 18016

2332  
2348  
40.83

Service	Charges
Electric	1,276.41
Electric (x)	0.00
Demand	824.77
Power Cost Adj	9.00
Tax	57.85
Sewer	58.79
EPA Mandated(f)	2.15

Please donate to our Neighbors in Need Fund. Funds collected help St Charles residents with their utility bills. This is the year to donate, due to COVID many of our neighbors are struggling. For information, call 630 377 4426.

A list of senior services is on our website [www.stcharlesil.gov/residents/resources-seniors](http://www.stcharlesil.gov/residents/resources-seniors) or pick up a printed Senior Citizens Resource guide in the lobby at City Hall.

Protect yourself and others ... wear a mask.

\$ 58.79  
\$2,100.98

<b>Amount Past Due</b>	\$2,483.81
<b>Current Charges</b>	\$2,219.77
<b>Total Amount Due</b>	\$4,703.58

Electric Rate 5

No payment was received since last billing.

\* Due date is only applicable to the current charges  
Past due charges are due immediately

(x) Compound meter

(f) EPA Mandated Project Fee

PAYMENTS RECEIVED AFTER **DUE DATE** ARE CONSIDERED LATE & CURRENT CHARGES WILL BE SUBJECT TO A 10% PENALTY.  
FAILURE TO RECEIVE BILL DOES NOT RELIEVE OBLIGATION TO PAY. PLEASE BRING ENTIRE BILL IF PAYING IN PERSON.  
PLEASE DETACH AND RETURN BOTTOM PORTION IF PAYING BY MAIL. ALLOW 5 DAYS FOR MAILING.  
DO NOT INCLUDE OTHER CITY PAYMENTS.

IL29701F



**City of St. Charles**

2 E MAIN ST  
ST CHARLES IL 60174-1984  
Return Service Requested

**Account Number:** 4-54-90835-1-0

**Due Date:** 12/31/2020

**Total Amount Due** \$4,703.58

**Total Amount Due AFTER Due Date** \$4,703.58

\*\*\*\*\*SNGLP

TRI COM CENTRAL DISPATCH  
3823 KARL MADSEN DR  
ST CHARLES IL 60175-7548

1  
118

CITY OF ST CHARLES  
PO BOX 6021  
CAROL STREAM IL 60197-6021



45490835100004703582