

Description:

Sentry Sprinklers Model DH68 is a ductile iron body, Dry Barrel Fire Hydrant with self-draining ports at the shoe flange. The hydrant offers high flow with a main valve opening of 5 ¼". The hydrant is anti-corrosion with 10 mil (250µ) of Polyurethane Ultraviolet-Proof coating on the outside and 6 mil (150µ) on the inside. All other components are made of corrosion resistance materials.

Features:

- Main Valve opening 5 ¼".
- NST Hose Nozzles.
- NST Pumper Nozzle.
- Conforms to AWWA C502, UL 246 and FM 1510.
- Maximum working pressure 250 PSI.
- Open left.
- 1 ½" Pentagon Operating Nut.
- 6" Shoe Flange connection ANSI Class 125/150 or BS EN1092-2 PN10/PN16.
- End Connection Shoe Flange available in Flange type (F) or Mechanical Joint (MJ).
- Color Red.



Model DH68  

Dimensions:

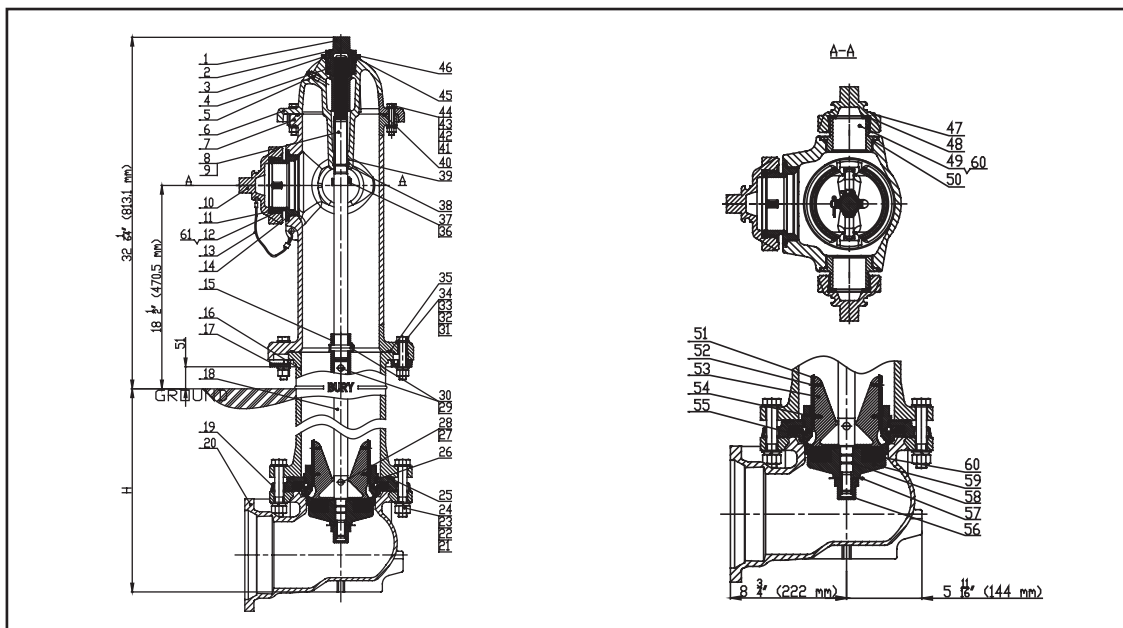

Material List:

ITEM	NAME	MATERIAL
1	Operating Nut	C84400
2	Dust Ring	EPDM
3	Lock Nut	CF8
4	Antifriction pad	C63000
5	Plug	SS304
6	Cover	65-45-12
7	Top Body	65-45-12
8	Top Shaft	SS420
9	Tube	Copper
10	Hose Nozzle Cap (4.5")	65-45-12
	Hose Nozzle Cap (4")	65-45-12
11	Hose Nozzle Gasket (4.5")	EPDM
	Hose Nozzle Gasket (4")	EPDM
12	Hose Nozzle (4.5")	C84400
	Hose Nozzle (4")	C84400
13	Chain	SS304
14	O-Ring	EPDM
15	Coupling	SS420
16	Down Body	65-45-12
17	Safety Flange	A126B
18	Down Shaft	SS420
19	Drainage Ring Cover	65-45-12
20	Elbow Body	65-45-12
21	Hexagon Bolt	SS304
22	Plain Washer	SS304
23	Lock Washer	SS304
24	Hexagon Nut	SS304
25	O-Ring	EPDM
26	O-Ring	EPDM
27	Pin Shaft	SS304
28	Pin	
29	Pin Shaft	SS304

ITEM	NAME	MATERIAL
30	Pin	SS304
31	Hexagon Bolt	SS304
32	Plain Washer	SS304
33	Lock Washer	SS304
34	Hexagon Nut	SS304
35	O-Ring	EPDM
36	Pin Shaft	SS304
37	Pin	SS304
38	O-Ring	EPDM
39	O-Ring	EPDM
40	O-Ring	EPDM
41	Hexagon Bolt	SS304
42	Plain Washer	SS304
43	Lock Washer	SS304
44	Hexagon Nut	SS304
45	O-Ring	EPDM
46	O-Ring	EPDM
47	Hose Nozzle Cap	65-45-12
48	Hose Nozzle Gasket	EPDM
49	Hose Nozzle	C84400
50	O-Ring	EPDM
51	Drain valve sealing strip	PE
52	Cross groove head screw	SS304
53	Disc	C84400
54	Seat Ring	C84400
55	Drainage Ring	C84400
56	Nut	65-45-12
57	Nut Washer	SS304
58	O-Ring	EPDM
59	Pressure Ring	65-45-12
60	Seat Ring	EPDM
61	Hexagon Socket Set Screw	Carbon steel + Zinc



Fire Protection

Model DH68
Dry Barrel Fire Hydrant

Technical Specifications:

Design Standard	FM 1510/UL 246/AWWA C502
Nozzle Thread Standard	NFPA 1963
Hose Nozzle	2-1/2" -Two
Pumper Nozzle	4" or 4-1/2"- One
Mechanical Joint	Size 6" ANSI/AWWA C153/A21.53
Flange End	Size 6" ANSI Class 125/150 BS EN1092-2 PN10/ PN16
Working Pressure	250 PSI

Model Options:

MODEL NO.	HOSE NOZZLE	PUMPER NOZZLE	MONITOR FLANGE	PIPE FLANGE
DH68-2525-45-00	2 * 2.5"	4.5"	NA	6"
DH68-2525-40-00	2 * 2.5"	4"	NA	6"

Burry Depth:

BURRY DEPTH (H)									
	A	B	C	D	E	F	G	H	K
H in	3'	3'-6"	4'-0"	4'-6"	5'-0"	5'-6"	6'-0"	6'-6"	7'-0"
H mm	912	1065	1217	1340	1522	1674	1827	1979	2132

CONNECTION CODE	FLANGE → FF	MECHANICAL JOINT → MJ
-----------------	-------------	-----------------------

FLANGE CODE	CLASS ANSI 125 → A	CLASS ANSI 150 → B	CLASS PN 10 → C	CLASS PN16 → D
-------------	--------------------	--------------------	-----------------	----------------

ORDER KEY	MODEL ↓	HOSE NOZZLE ↓	PUMPER NOZZLE ↓	MONITOR FLANGE ↓	BURRY DEPTH ↓	CONNECTION CODE ↓	PIPE FLANGE CODE ↓
	DH68-	XXXX-	XX-	XX-	X-	XX-	X