

MADE IN THE USA

EX-1700 V.2026

SOLAR SECURITY TRAILER



All in one camera unit with just options including, 2 Way Speakers, LTE Connectivity, 360° Monitoring, LED strobe lights, and more.

Flexible Recharge Options

Charge with 120VAC Shore Power, Remote Solar Power, or an Optional Generator

Rugged Steel Construction

Built to be pushed in the roughest surveillance environments

Modular Deployment Options

Customizable to fit any application, from lighting to job site power or a mobile surveillance headquarters



Solar Surveillance Trailer

For Cameras, Communications, and Lighting

21' (Extended)



Telescopic Mast

Quick deployment of mission-critical equipment on a stable platform

Package Includes:

- Solar Trailer with 400W Solar
- 400Ah SLA Battery Bank
- 18' Telescopic Mast
- Manual Mast Winch
- Standard jacks on Corners
- 2-Tone White/Black Finish

Autonomous Solar Operation

Handle any surveillance deployment, with up to 1600W of solar power

Industrial Powder Coating Topcoat
Sleek, attractive, and extremely

MDT Quick Specs	MDT-400	MDT-800	MDT-1200	MDT-1600
Solar Power Available	400 Watt	800 Watt	1200 Watt	1600 Watts
Equipment Cabinet Size (H x W x D)	32.45" x 15" x 9"			
Travel Footprint (L x W)	117" x 68" (-9.75' x 5.7')			117" x 82" (-9.75' x 6.8')
Deployed Footprint (L x W)	131" x 68" (-10.91' x 5.7')	131" x 90" (-10.91' x 7.5')	131" x 125" (-10.91' x 10.41')	131" x 162" (-10.91' x 13.5')
Build Material	Industrial Powder Coated Steel			
Total Weight (with 2 x 210Ah Batteries)	~1,900lbs		~2100lbs	
Mast Height (Extended)	21 Feet			
Mast Height (Collapsed)	6.8 Feet			
Max Mast Payload	65lbs			
Number of Mast Sections	2 or 3 Stabilized Steel Sections			
Solar Array Configuration	1 x ~400W Panels	2 x ~400W Panels	3 x ~400W Panels	4 x ~400W Panels
Solar Charge Technology	Advanced MPPT			
Continuous Power Available (in Solar Zone 3)	36 Watts	72 Watts	108 Watts	148W
AC Power Input	110VAC			
Operating Temperature	-22° to 140° F (-30° to 60° C)			
Axle Weight Rating	2,500lbs			
Power Output	DC Output: 24VDC, 5A Max AC Output: 115VAC, 375W Max			
Coiled Cable	16/4 Stranded and 2 CAT5e Stranded			
Battery Capacity	400Ah Standard; 800Ah and 1200Ah Options Available (800Ah Max when used with Generator)			
Connectivity	Remote monitoring of system health, alerting, and power cycling options			

Solar Map of the US

Solar Array Size	Zone 1 Watts	Zone 2 Watts	Zone 3 Watts	Zone 4 Watts	Zone 5 Watts
100W	15	12.5	9.5	6.5	3.5
200W	30	25	19	13	7
300W	45	37.5	28.5	19.5	10.5
400W	60	50	38	26	14
600W	90	75	57	39	21
800W	120	100	76	52	28
1200W	180	150	114	78	42
1600W	240	200	152	104	56
Peak Winter Sun Hrs	4.5	3.5	2.7	1.8	1



Power Assembly of the Solar Trailer

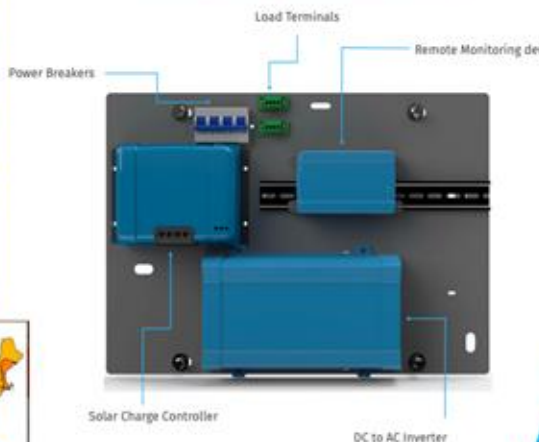

Shipping and Assembly

The Surveillance Trailer is shipped partially disassembled as shown here. The trailer can be assembled in 90 minutes between a team of 2 people. A fork lift is recommended for unloading and assembly. A torque wrench will be needed to tighten hardware to correct tightness. Power tools are recommended as well.



2 Off-Road Tires



1 Trailer Base, Body, Solar Array, & Telescopic Mast

1 3/8" Mast Extension



1 Tail Light Plate



2 Wheel Fenders



2 Split Axles



1 Axle Channel, 2 Axle Bracers & 2 Support Brackets



4 Stabilizing Jacks



1 Detachable Hitch with Locking Pins

1600W Trailer Packed

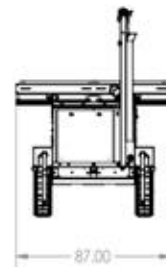

1600W Trailer Deployed

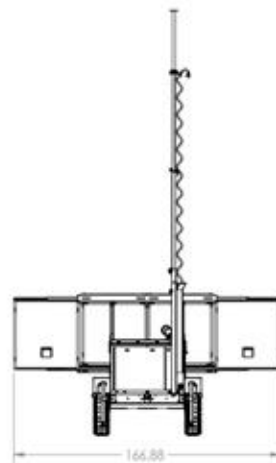

Solar Trailer Measurements

1200W Trailer
Packed

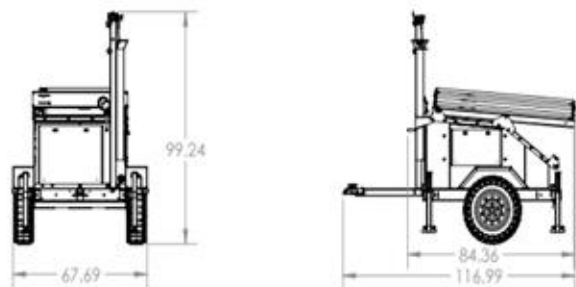

1200W Trailer
Deployed

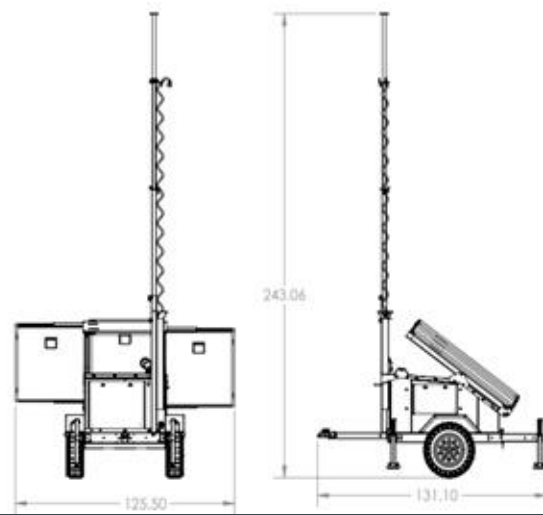

Solar Trailer Measurements

800W Trailer
Packed

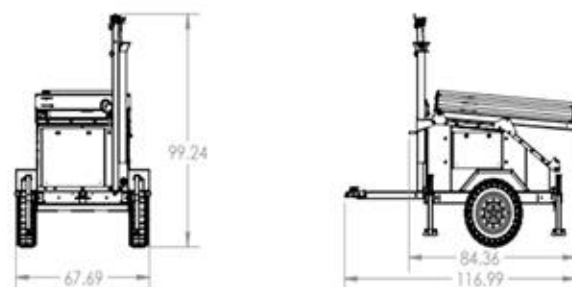

800W Trailer
Deployed

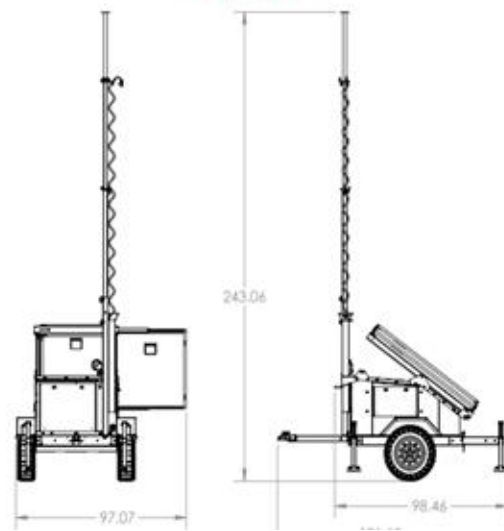



leo@elitexpert.tech

Solar Trailer Measurements

400W Trailer
Packed

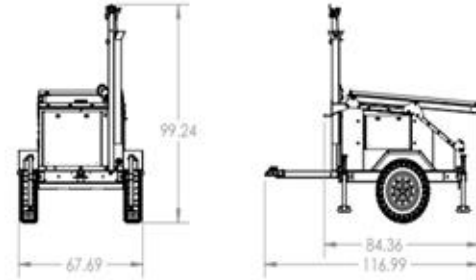

400W Trailer
Deployed

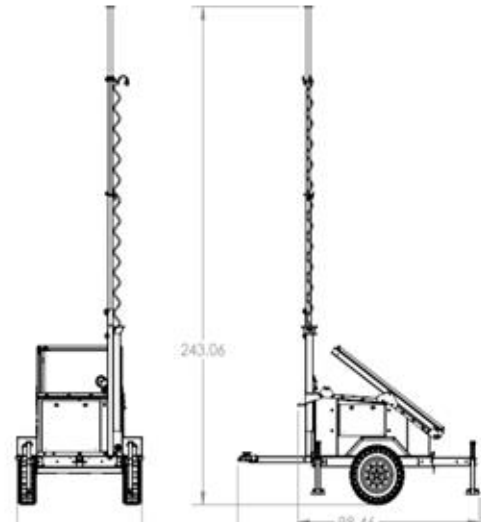



24/7 LIVE VIEW

Enhanced detection and rapid response capabilities, delivering superior security efficiency for continuous protection.



ROBUST NVR

Our Mobile Surveillance trailers support a **rugged local NVR** with advanced storage and remote access, designed to withstand **harsh environments** and demanding conditions.



CELLULAR OR WIFI

Our **mobile surveillance trailer** provides seamless **cellular and WiFi connectivity** for uninterrupted remote monitoring.



COST EFFECTIVE

Rent or purchase our **solar powered trailers** with flexible terms and competitive pricing. Our **Mobile solar trailers** have a price that cannot be beat by any competitors.