



**HARLEY-DAVIDSON**



# TOURING MODELS

2021 HARLEY-DAVIDSON® SERVICE MANUAL  
94000834

## **IMPORTANT NOTICE**

**Harley-Davidson motorcycles conform to all applicable U.S.A. Federal Motor Vehicle Safety Standards and U.S.A. Environmental Protection Agency regulations effective on the date of manufacture.**

**To maintain the safety, dependability, and emission and noise control performance, it is essential that the procedures, specifications and service instructions in this manual are followed.**

**Any substitution, alteration or adjustment of emission system and noise control components outside of factory specifications may be prohibited by law.**

**Harley-Davidson Motor Company**



## **TOURING MODELS**

**2021 HARLEY-DAVIDSON® SERVICE MANUAL**

©2020 H-D.

ALL RIGHTS RESERVED

PRINTED IN THE USA

CMI - 5M - 07/20

94000834

VISIT THE HARLEY-DAVIDSON WEB SITE

<http://www.harley-davidson.com>

# READER'S COMMENTS

The Harley-Davidson Service Communications Department maintains a continuous effort to improve the quality and usefulness of its publications. To do this effectively, we need user feedback - your critical evaluation of this manual.

Please comment on the completeness, accuracy, organization, usability, and readability of this manual.

Please list the page, item, and part number(s) of any errors you find in this manual.

Please tell us how we can improve this manual.

|            |       |                      |
|------------|-------|----------------------|
| Name       |       | Document<br>94000451 |
| Occupation |       | Dealership           |
| Street     |       | Department           |
| City       | State | Zip                  |

2021 HARLEY-DAVIDSON® SERVICE MANUAL - TOURING MODELS

- Return this form to:  
Harley-Davidson Motor Company  
Department 625 Service Communications  
P.O. Box 653  
Milwaukee WI 53201 USA

**PLEASE ADD ANY OTHER COMMENTS HERE**



## Customer Safety

### A WARNING

Harley-Davidson service manuals are intended for use by professional, qualified and experienced technicians. Attempting the procedures found within this manual without the proper training, tools and equipment could result in death or injury to you or others. This could also damage the vehicle, or cause the vehicle to operate improperly.

Safety is always the most important consideration when performing any job.

- Always have a complete understanding of the task.
- Use common sense.
- Use proper tools for the task.
- Protect yourself and bystanders with approved eye protection.

Harley-Davidson does not evaluate or advise the technicians of every way in which service might be performed, or all possible hazardous consequences of every method, or undertaken such a broad evaluation. Before using a tool not recommended by Harley-Davidson, make sure that technician or rider safety will not be jeopardized as a result.

Warnings against the use of specific service methods which could damage the motorcycle or render it unsafe are stated in this manual. **These warnings are not all-inclusive.** Inadequate safety precautions could result in death or serious injury.

## Safety Messages

Statements in this manual preceded by the following words are of special significance.

### A DANGER

**DANGER** indicates a hazardous situation which, if not avoided, will result in death or serious injury. (08704a)

### A WARNING

**WARNING** indicates a potentially hazardous situation which, if not avoided, could result in death or serious injury. (00119a)

### A CAUTION

**CAUTION** indicates a potentially hazardous situation which, if not avoided, may result in minor or moderate injury. (00139a)

### NOTICE

**NOTICE** indicates a potentially hazardous situation which, if not avoided, may result in property damage. (00140b)

### NOTE

*Refers to important information. It is recommended that you take special notice of these items.*

**The rider's safety depends upon proper motorcycle service and maintenance. If a procedure in this manual is not within your capabilities or you do not have the correct tools, have a Harley-Davidson dealer perform the procedure. Improper service or maintenance could result in death or serious injury. (00627b)**

Proper service and repair is important for the safe, reliable operation of all mechanical products. The service procedures recommended and described in this manual are effective methods for performing service operations and are essential to your customer's safety and the reliable and safe operation of your customer's vehicle.

## Personal Protection

### A WARNING

- **Always wear safety glasses or goggles when performing service or maintenance procedures. Flying objects or materials can cause serious eye injury or death.**
- **Wear protective gear that is appropriate to the situation. Helmets, gloves, boots and other protective clothing can prevent serious injury or death.**
- **Wear ear protection when loud noises are present. Loud noises can damage ears and cause hearing loss.**

(00628b)

## Tool Safety

Some of these service operations require the use of tools specially designed for the purpose. Follow the manufacturer's suggested usage and safety instructions. If using a tool other than that recommended by Harley-Davidson, be sure that the tool is appropriate for the service or maintenance procedure and is being used in accordance with the tool's safety instructions.

## Product Safety

### A WARNING

**Read and follow warnings and directions on all products. Failure to follow warnings and directions can result in death or serious injury. (00470b)**

- When reference is made to a specific brand name product, tool or instrument, an equivalent product, tool or instrument may be substituted.
- Some referenced or recommended products contain chemicals known to the State-of California to cause cancer and birth defects or other reproductive harm as indicated on the product label or at the point of purchase.

## Hazardous Materials

### A WARNING

**Read and follow warnings and directions on all products. Failure to follow warnings and directions can result in death or serious injury. (00470b)**

- Keep hazardous products out of the reach of children.
- Many products (oils, lubricants, solvents, sealants and cleaners, etc.) can cause death or serious injury if inhaled, absorbed, injected, ingested or improperly contacted. If hazardous contact is made with a product, follow the instructions on the product label and, if necessary, contact poison control or a medical facility.
- Some products are flammable and/or explosive as indicated on the product label or at the point of purchase. Keep these products away from flame and intense heat.
- Some products are corrosive as indicated on the product label. Wear appropriate protective gear to prevent skin contact. Use service covers to prevent damage to cosmetic surfaces on the motorcycle.
- Some products contain chemicals known to the State of California to cause cancer and birth defects or other reproductive harm as indicated on the product label or at the point of purchase.

## Fuel

### A WARNING

**Keep gasoline away from ignition sources. Gasoline is extremely flammable and highly explosive and, if ignited, could result in death or serious injury. (00634b)**

- Stop the engine when refueling or servicing the fuel system.
- Do not allow open flame, sparks, radiant heat or other ignition sources near gasoline.
- Do not store motorcycle with gasoline in tank within the home or garage where ignition sources, such as open flames, pilot lights, sparks or electric motors are present.
- Do not overfill fuel tank. Allow for fuel expansion .
- Do not use gasoline as a cleaner or solvent.
- Gasoline can leak or drain from loosened or improperly tightened fuel fittings or from removed fuel components.
- Clean spilled gasoline immediately. Dispose of waste materials properly.

## Battery

### A WARNING

**Read and follow warnings and directions on all products. Failure to follow warnings and directions can result in death or serious injury. (00470b)**

- Batteries contain sulfuric acid, which could cause severe burns to eyes and skin. Wear a protective face shield, rubberized gloves and protective clothing when working with batteries. Keep batteries out of the reach of children.
- Do not remove warning label attached to top of battery.

- Batteries, battery posts, terminals and related accessories contain lead and lead compounds, and other chemicals known to the State of California to cause cancer, and birth defects or other reproductive harm. Wash hands after handling.

## Coolant

- Coolant contains toxic chemicals which could cause death or serious injuries if ingested. Do not induce vomiting. Call a physician immediately.
- Irritation to skin or eyes can occur from vapors or direct contact. Flush thoroughly with water if contact is made.
- Use in a well ventilated area.

## Hydraulic (Brake) Fluid

- Direct contact with brake fluid to the eyes can cause irritation. Flush thoroughly with water if contact is made.
- Do not swallow brake fluid. Swallowing brake fluid can cause digestive discomfort. Call a physician immediately.
- Brake fluid will cause cosmetic damage to painted surfaces. Always use caution and protect surfaces from spills whenever brake work is performed.

## Engine Oil

- Prolonged or repeated contact with used motor oil may be harmful to skin and could cause skin cancer. Promptly wash affected areas with soap and water.
- Do not swallow oil. If swallowed, do not induce vomiting. Contact a physician immediately.
- Direct contact with eyes can cause irritation. Flush thoroughly with water if contact is made. Contact a physician if irritation persists.

## Electrical Systems

### A WARNING

**Improper service or maintenance of the electrical system can cause damage to the electrical system. This may result in component failure. In certain situations, a component failure during operation could lead to a loss of control, which could result in death or serious injury. (00637b)**

- Always use replacement fuses that are of the specified type and amperage rating.
- Do NOT pull on electrical wires. Pulling on electrical wires may damage wire conductivity.
- Route wires and harnesses properly to prevent chafing, stripping, pinching, crimping or cutting wires. Damaged wires can cause short circuits and component damage or failure.
- Do NOT overload the vehicle's charging system. If the electrical accessories consume more electrical current than the charging system can produce, the battery may be discharged and cause damage to the motorcycle's electrical system.
- Do NOT exceed the maximum amperage rating of the fuse or circuit breaker protecting a modified circuit.
- Avoid directly heating electrical system components other than the connectors on which heat shrink work is being performed.





| <b>SUBJECT</b>   | <b>PAGE NO.</b> |
|--|-----------------|
| 2.1 FASTENER TORQUE VALUES .....                       | 2-1             |
| 2.2 GENERAL.....                                       | 2-3             |
| 2.3 MAINTENANCE SCHEDULE .....                         | 2-4             |
| 2.4 FUEL AND OIL .....                                 | 2-7             |
| 2.5 REPLACE ENGINE OIL AND FILTER .....                | 2-9             |
| 2.6 REPLACE PRIMARY CHAINCASE LUBRICANT .....          | 2-11            |
| 2.7 REPLACE TRANSMISSION LUBRICANT .....               | 2-13            |
| 2.8 INSPECT TIRES AND WHEELS .....                     | 2-15            |
| 2.9 LUBRICATE CABLES AND CHASSIS.....                  | 2-18            |
| 2.10 INSPECT BRAKES .....                              | 2-19            |
| 2.11 CHECK AND REPLACE BRAKE FLUID .....               | 2-24            |
| 2.12 CHECK AND ADJUST CLUTCH.....                      | 2-27            |
| 2.13 REBUILD FRONT FORK AND REPLACE OIL .....          | 2-30            |
| 2.14 ADJUST AND LUBRICATE STEERING HEAD BEARINGS ..... | 2-31            |
| 2.15 INSPECT RADIATOR AND COOLANT .....                | 2-34            |
| 2.16 INSPECT FUEL LINES AND FITTINGS .....             | 2-35            |
| 2.17 INSPECT AND LUBRICATE JIFFY STAND .....           | 2-36            |
| 2.18 INSPECT AND ADJUST DRIVE BELT AND SPROCKETS ..... | 2-37            |
| 2.19 INSPECT REAR SPROCKET ISOLATOR .....              | 2-42            |
| 2.20 ADJUST SUSPENSION .....                           | 2-43            |
| 2.21 INSPECT EXHAUST SYSTEM.....                       | 2-45            |
| 2.22 INSPECT AIR FILTER .....                          | 2-46            |
| 2.23 INSPECT BATTERY .....                             | 2-48            |
| 2.24 CLEAN AND INSPECT SPARK PLUGS .....               | 2-50            |
| 2.25 STORAGE .....                                     | 2-52            |
| 2.26 TROUBLESHOOTING .....                             | 2-54            |

## NOTES



## FASTENER TORQUE VALUES IN THIS CHAPTER \_\_\_\_\_

| FASTENER   | TORQUE VALUE   |               | NOTES   |
|--|----------------|---------------|---|
| Air cleaner cover screw  | 36-60 in-lbs   | 4.1-6.8 N-m   | 2.22 INSPECT AIR FILTER, Install<br>Apply LOCTITE 243 (blue) to the threads of screw.             |
| Air cleaner insert screws  | 27-32 in-lbs   | 3.1-3.6 N-m   | 2.22 INSPECT AIR FILTER, Install  |
| Air filter element screws, oval                                    | 50-60 in-lbs   | 5.6-6.8 N-m   | 2.22 INSPECT AIR FILTER, Install<br>Apply LOCTITE 243 (blue) to the threads of screws.            |
| Air filter element screws, standard                                | 40-60 in-lbs   | 4.5-6.8 N-m   | 2.22 INSPECT AIR FILTER, Install  |
| Battery cables screws  | 60-70 in-lbs   | 6.8-7.9 N-m   | 2.23 INSPECT BATTERY, Install   |
| Brake bleeder screw, front   | 72-108 in-lbs  | 8.1-12.2 N-m  | 2.11 CHECK AND REPLACE BRAKE FLUID, Drain<br>and Replace Fluid                                    |
| Brake bleeder screw, rear  | 75-102 in-lbs  | 8.5-11.5 N-m  | 2.11 CHECK AND REPLACE BRAKE FLUID, Drain<br>and Replace Fluid                                    |
| Brake master cylinder, front, reservoir<br>cover screws            | 12-15 in-lbs   | 1.4-1.7 N-m   | 2.11 CHECK AND REPLACE BRAKE FLUID, Drain<br>and Replace Fluid                                    |
| Brake master cylinder, rear, reservoir<br>cover screws             | 12-15 in-lbs   | 1.4-1.7 N-m   | 2.11 CHECK AND REPLACE BRAKE FLUID, Drain<br>and Replace Fluid                                    |
| Brake pad pin  | 75-102 in-lbs  | 8.5-11.5 N-m  | 2.10 INSPECT BRAKES, Replace Front Brake Pads   |
| Brake pad pin  | 75-102 in-lbs  | 8.5-11.5 N-m  | 2.10 INSPECT BRAKES, Replace Rear Brake Pads  |
| Clutch hub jamnut  | 72-120 in-lbs  | 8.1-13.6 N-m  | 2.12 CHECK AND ADJUST CLUTCH, Check and<br>Adjust   |
| Clutch inspection cover screws                                     | 84-108 in-lbs  | 9.5-12.2 N-m  | 2.6 REPLACE PRIMARY CHAINCASE LUBRICANT,<br>Change Primary Chaincase Lubricant<br>Torque sequence |
| Engine oil drain plug  | 14-21 ft-lbs   | 19-28.5 N-m   | 2.5 REPLACE ENGINE OIL AND FILTER, Change<br>Oil and Oil Filter                                   |
| Muffler to saddlebag support screws                                | 14-18 ft-lbs   | 19-24.4 N-m   | 2.18 INSPECT AND ADJUST DRIVE BELT AND<br>SPROCKETS, Adjust Belt                                  |
| Primary chaincase drain plug                                       | 14-21 ft-lbs   | 19-28.5 N-m   | 2.6 REPLACE PRIMARY CHAINCASE LUBRICANT,<br>Change Primary Chaincase Lubricant                    |
| Rear axle cone nut, 1st torque                                     | 15-20 ft-lbs   | 20-27 N-m     | 2.18 INSPECT AND ADJUST DRIVE BELT AND<br>SPROCKETS, Adjust Belt<br>For belt adjustment only      |
| Rear axle cone nut, final torque                                   | 135-145 ft-lbs | 183-196.6 N-m | 2.18 INSPECT AND ADJUST DRIVE BELT AND<br>SPROCKETS, Adjust Belt                                  |
| Spark plug   | 89-133 in-lbs  | 10-15 N-m     | 2.24 CLEAN AND INSPECT SPARK PLUGS, Install   |
| Spoke nipple   | 55 in-lbs      | 6.2 N-m       | 2.8 INSPECT TIRES AND WHEELS, Wheel Spokes  |
| Transmission drain plug  | 14-21 ft-lbs   | 19-28.5 N-m   | 2.7 REPLACE TRANSMISSION LUBRICANT,<br>Change Transmission Lubricant                              |
| Transmission filler plug/dipstick                                  | 25-75 in-lbs   | 2.8-8.5 N-m   | 2.7 REPLACE TRANSMISSION LUBRICANT, Check<br>Transmission Lubricant                               |
| Transmission filler plug/dipstick                                  | 25-75 in-lbs   | 2.8-8.5 N-m   | 2.7 REPLACE TRANSMISSION LUBRICANT,<br>Change Transmission Lubricant                              |
| Upper steering stem, final torque: Fork<br>mounted fairing models  | 63 in-lbs      | 7.1 N-m       | 2.14 ADJUST AND LUBRICATE STEERING HEAD<br>BEARINGS, Lubricate                                    |
| Upper steering stem, final torque: Frame<br>mounted fairing models | 192 in-lbs     | 21.7 N-m      | 2.14 ADJUST AND LUBRICATE STEERING HEAD<br>BEARINGS, Lubricate                                    |

| FASTENER  | TORQUE VALUE      |               | NOTES  |
|---|-------------------|---------------|--|
| Upper steering stem, final torque: Road King models | 108 <b>in-lbs</b> | 12.2 N·m      | 2.14 ADJUST AND LUBRICATE STEERING HEAD BEARINGS, Lubricate        |
| Upper steering stem, final torque: Trike models     | 108 <b>in-lbs</b> | 12.2 N·m      | 2.14 ADJUST AND LUBRICATE STEERING HEAD BEARINGS, Lubricate        |
| Upper steering stem, first torque                   | 35 ft-lbs         | 47.5 N·m      | 2.14 ADJUST AND LUBRICATE STEERING HEAD BEARINGS, Lubricate        |
| Upper steering stem pinch screw                     | 22-26 ft-lbs      | 29.8-35.2 N·m | 2.14 ADJUST AND LUBRICATE STEERING HEAD BEARINGS, Check and Adjust |

**SERVICING A NEW MOTORCYCLE****SECURE THE MOTORCYCLE FOR SERVICE****A WARNING**

Perform the service and maintenance operations as indicated in the regular service interval table. Lack of regular maintenance at the recommended intervals can affect the safe operation of your motorcycle, which could result in death or serious injury. (0001 0a)

Perform necessary set-up tasks before customer delivery. See applicable model year predelivery and set-up instructions.

The performance of new motorcycle initial service is required to keep warranty in force and to verify proper emissions systems operation. See MAINTENANCE SCHEDULE (Page 2-4).

Inspect motorcycle regularly for additional maintenance needs. Routinely check components between regular maintenance intervals. Always inspect motorcycle after periods of storage before riding.

Perform all of the checks in the PRE-RIDING CHECKLIST in the owner's manual following any service procedure. Operate the motorcycle to perform any final check or adjustments. If all is correct, the vehicle is ready to return to the customer.

| PART NUMBER | TOOL NAME |
|-------------|-----------|
| HD-45968    | FAT JACK  |

**A WARNING**

Be sure to check capacity rating and condition of hoists, slings, chains and cables before use. Exceeding capacity ratings or using lifting devices that are in poor condition can lead to an accident, which could result in death or serious injury. (00466c)

Always use blocking or proper stands to support motorcycle.

**Set Motorcycle Upright**

1. Place motorcycle upright on a level surface or suitable lift if available.
2. Verify that motorcycle is level.
3. Secure with tie-downs.

**Raise Front or Rear Wheel for Service**

1. Verify that motorcycle is level.
2. Use a FAT JACK (PART NUMBER: HD-45968) or similar to raise the motorcycle to service a front or rear wheel.
3. Secure with tie-downs.

## GENERAL

### Regular Service Intervals

Service must be performed at specified intervals to keep your Harley-Davidson motorcycle operating at peak performance. See the Regular Service Intervals table below.

**NOTE**

- The use of parts and service procedures other than Harley-Davidson approved parts and service procedures may void the limited warranty. Any alterations to the emission system components, such as the intake and exhaust system, may be in violation of motor vehicle laws.
- Some countries, such as Brazil, may require all regular maintenance to be performed by an authorized Harley-Davidson dealer for your limited warranty to remain in effect. Check with your authorized Harley-Davidson dealer.
- Some countries, such as Brazil, may require additional annual (or semi-annual) regular maintenance steps to be performed to keep your limited warranty in effect and/or comply with vehicle regulations. Check with your authorized Harley-Davidson dealer as well as the motorcycle regulations in your country.
- After completing the final service interval, repeat the service schedule starting at the 8000 km (5000 mi) interval.
- Whenever a vehicle is in for maintenance, always check for

and complete recalls and open product programs.

- Whenever a vehicle is in for maintenance, always verify that the latest calibration is installed.

For vehicles equipped with the Boom! Box GTS radio, reset the Distance Since Last Service feature once service is complete.

1. Enter Service Mode.
  - a. Turn ignition off.
  - b. Wait 15 seconds.
  - c. Turn ignition to accessory (ACC) position.
  - d. Wait ten seconds for the WARNING screen to display.
  - e. Press and hold power/mute button until service menu is displayed.
2. Select: Reset.
3. Select: Mileage Reset.
4. Select: Yes. Confirms mileage reset.

Table 2-1. Regular Service Intervals: Harley-Davidson Touring Models

| COMPONENT   | ACTION    |                    |                    |                      |                      |                      |                      |                      |                      |                      |                      |                      | NOTES  |
|---|-----------|--------------------|--------------------|----------------------|----------------------|----------------------|----------------------|----------------------|----------------------|----------------------|----------------------|----------------------|--------|
|   |           | 1600 KM<br>1000 MI | 8000 KM<br>5000 MI | 16000 KM<br>10000 MI | 24000 KM<br>15000 MI | 32000 KM<br>20000 MI | 40000 KM<br>25000 MI | 48000 KM<br>30000 MI | 56000 KM<br>35000 MI | 64000 KM<br>40000 MI | 72000 KM<br>45000 MI | 80000 KM<br>50000 MI |        |
| Service Intervals   |           |                    |                    |                      |                      |                      |                      |                      |                      |                      |                      |                      |        |
| Electrical equipment and switches   | Inspect   | x                  | x                  | x                    | x                    | x                    | x                    | x                    | x                    | x                    | x                    | x                    |        |
| Front tire pressure and tread   | Check     | x                  | x                  | x                    | x                    | x                    | x                    | x                    | x                    | x                    | x                    | x                    | 1      |
| Front wheel spoke tightness (if equipped)   | Check     | x                  | x                  |                      |                      |                      |                      |                      |                      |                      |                      |                      | 2,4, 3 |
| Front brake fluid level   | Inspect   | x                  | x                  | x                    | x                    | x                    | x                    | x                    | x                    | x                    | x                    | x                    | 7      |
| Clutch cable  | Lubricate | x                  | x                  | x                    | x                    | x                    | x                    | x                    | x                    | x                    | x                    | x                    | 9      |
| Clutch cable  | Adjust    | x                  | x                  | x                    | x                    | x                    | x                    | x                    | x                    | x                    | x                    | x                    | 6, 2   |
| Front brake fluid moisture content  | Check     | x                  | x                  | x                    | x                    | x                    | x                    | x                    | x                    | x                    | x                    | x                    | 1,2    |
| Hand control switch housing screw torque  | Tighten   | x                  |                    | x                    |                      |                      |                      |                      |                      |                      |                      |                      | 1,2, 5 |
| Clutch lever handlebar clamp screw torque   | Tighten   | x                  |                    | x                    |                      |                      |                      |                      |                      |                      |                      |                      | 1,2, 5 |
| Front brake handlebar clamp screw torque  | Tighten   | x                  |                    | x                    |                      |                      |                      |                      |                      |                      |                      |                      | 1,2, 5 |
| Steering head bearings  | Lubricate |                    |                    |                      |                      |                      |                      |                      |                      |                      |                      |                      | 2      |
| Windshield bushings (if equipped)   | Inspect   |                    |                    | x                    |                      |                      |                      |                      |                      |                      |                      |                      |        |
| Air cleaner filter  | Inspect   |                    | x                  | x                    | x                    | x                    | x                    | x                    | x                    | x                    | x                    | x                    | 3      |
| <b>NOTES</b>  |           |                    |                    |                      |                      |                      |                      |                      |                      |                      |                      |                      |        |
| 1. Perform annually or at specified intervals, whichever comes first.   |           |                    |                    |                      |                      |                      |                      |                      |                      |                      |                      |                      |        |
| 2. Should be performed by an authorized Harley-Davidson dealer, unless you have the proper tools, service data and are mechanically qualified.  |           |                    |                    |                      |                      |                      |                      |                      |                      |                      |                      |                      |        |
| 3. Perform maintenance more frequently in severe riding conditions. This includes extreme temperatures, dusty environments, mountainous or rough roads, long storage conditions, short runs, heavy stop/go traffic or poor fuel quality.              |           |                    |                    |                      |                      |                      |                      |                      |                      |                      |                      |                      |        |
| 4. Perform spoke tension check at 1,000 mi (2,000 km), 5,000 mi (8,000 km), 20,000 mi (32,000 km) services and every 15,000 mi (24,000 km) interval thereafter. Not all vehicles have spoked wheels. Consult appropriate topic in the service manual. |           |                    |                    |                      |                      |                      |                      |                      |                      |                      |                      |                      |        |
| 5. For torque instructions, see Shop Practices in the service manual.   |           |                    |                    |                      |                      |                      |                      |                      |                      |                      |                      |                      |        |
| 6. Check for leaks, contact or abrasion.  |           |                    |                    |                      |                      |                      |                      |                      |                      |                      |                      |                      |        |
| 7. Brake fluid level drops as brake pads wear.  |           |                    |                    |                      |                      |                      |                      |                      |                      |                      |                      |                      |        |
| 8. Check coolant freeze point and inspect for leaks.  |           |                    |                    |                      |                      |                      |                      |                      |                      |                      |                      |                      |        |
| 9. Use HARLEY LUBE.   |           |                    |                    |                      |                      |                      |                      |                      |                      |                      |                      |                      |        |



Table 2-1. Regular Service Intervals: Harley-Davidson Touring Models

| COMPONENT                                | ACTION    | INTERVALS  |                    |                      |                      |                      |                      |                      |                      |                      |                      |                      |      | NOTES   |
|--|-----------|--|--------------------|----------------------|----------------------|----------------------|----------------------|----------------------|----------------------|----------------------|----------------------|----------------------|------|---------|
|  |           | 1600 KM<br>1000 MI   | 8000 KM<br>5000 MI | 16000 KM<br>10000 MI | 24000 KM<br>15000 MI | 32000 KM<br>20000 MI | 40000 KM<br>25000 MI | 48000 KM<br>30000 MI | 56000 KM<br>35000 MI | 64000 KM<br>40000 MI | 72000 KM<br>45000 MI | 80000 KM<br>50000 MI |      |         |
| Engine oil and filter                    | Replace   | x  | x                  | x                    | x                    | x                    | x                    | x                    | x                    | x                    | x                    | x                    | x    | 1, 3    |
| Engine coolant                           | Check     | x  | x                  | x                    | x                    | x                    | x                    | x                    | x                    | x                    | x                    | x                    | x    | 8       |
| Engine coolant                           | Replace   |  |                    |                      |                      |                      |                      |                      |                      |                      | x                    |                      |      | 2       |
| Radiators or oil cooler                  | Clean     | x  | x                  | x                    | x                    | x                    | x                    | x                    | x                    | x                    | x                    | x                    | x    |         |
| Primary chaincase lubricant              | Replace   | x  |                    | x                    |                      | x                    |                      | x                    |                      | x                    |                      | x                    |      | 3       |
| Transmission lubricant                   | Replace   | x  |                    |                      |                      | x                    |                      |                      |                      | x                    |                      |                      |      | 3       |
| Oil and brake lines                      | Inspect   | x  | x                  | x                    | x                    | x                    | x                    | x                    | x                    | x                    | x                    | x                    | x    | 1,2, 6  |
| Fuel lines and fittings                  | Inspect   | x  | x                  | x                    | x                    | x                    | x                    | x                    | x                    | x                    | x                    | x                    | x    | 1,2, 6  |
| Rear brake fluid level                   | Inspect   | x  | x                  | x                    | x                    | x                    | x                    | x                    | x                    | x                    | x                    | x                    | x    | 7       |
| DOT4 rear brake fluid moisture content   | Check     | x  | x                  | x                    | x                    | x                    | x                    | x                    | x                    | x                    | x                    | x                    | x    | 1,2     |
| Brake systems                            | Replace   | _ Flush brake systems and replace DOT 4 hydraulic brake fluid every two years or sooner if moisture content is 3 percent or greater. |                    |                      |                      |                      |                      |                      |                      |                      |                      |                      | 2    |         |
| Brake pads and discs                     | Inspect   | x  | x                  | x                    | x                    | x                    | x                    | x                    | x                    | x                    | x                    | x                    | x    |         |
| Front axle nut torque                    | Tighten   | x  |                    | x                    |                      | x                    |                      | x                    |                      | x                    |                      | x                    |      | 1,2, 5  |
| Jiffy stand                              | Lubricate | x  | x                  | x                    | x                    | x                    | x                    | x                    | x                    | x                    | x                    | x                    | x    | 2, 3    |
| Brake and clutch controls                | Lubricate | x  | x                  | x                    | x                    | x                    | x                    | x                    | x                    | x                    | x                    | x                    | x    | 2, 9    |
| Rear wheel spoke tightness (if equipped) | Check     | x  | x                  |                      |                      | x                    |                      |                      |                      | x                    |                      |                      | x    | 2, 3, 4 |
| Rear tire pressure and tread             | Check     | x  | x                  | x                    | x                    | x                    | x                    | x                    | x                    | x                    | x                    | x                    | x    | 1       |
| Drive belt and sprockets                 | Inspect   | x  | x                  | x                    | x                    | x                    | x                    | x                    | x                    | x                    | x                    | x                    | x    | 2       |
| Drive belt                               | Adjust    | x  | x                  | x                    | x                    | x                    | x                    | x                    | x                    | x                    | x                    | x                    | x    | 2       |
| Rear sprocket isolators                  | Inspect   | Inspect rear sprocket isolators for wear at each rear tire change.   |                    |                      |                      |                      |                      |                      |                      |                      |                      |                      |      |         |
| Rear axle nut torque                     | Tighten   | x  |                    | x                    |                      | x                    |                      | x                    |                      | x                    |                      | x                    |      | 1,2, 5  |
| Exhaust system, fasteners and shields    | Inspect   | x  | x                  | x                    | x                    | x                    | x                    | x                    | x                    | x                    | x                    | x                    | x    | 1, 3    |
| 12 volt battery                          | Check     | Check battery, terminal torque and clean connections annually. Lubricate terminals with ELECTRICAL CONTACT LUBRICANT.                |                    |                      |                      |                      |                      |                      |                      |                      |                      |                      | 1    |         |
| Spark plugs                              | Replace   | Replace spark plugs every two years or every 30,000 mi (48,000 km), whichever comes first.   |                    |                      |                      |                      |                      |                      |                      |                      |                      |                      |      |         |
| Fuel door hinge and latch                | Lubricate | x  | x                  | x                    | x                    | x                    | x                    | x                    | x                    | x                    | x                    | x                    | x    | 9       |
| Front forks                              | Rebuild   |  |                    |                      |                      |                      |                      |                      |                      |                      |                      |                      | x    | 2       |
| Fuel filter                              | Replace   | Replace fuel filter element every 100,000 mi (161,000 km).   |                    |                      |                      |                      |                      |                      |                      |                      |                      |                      | 2, 3 |         |
| Component and system functions           | Road Test | x  | x                  | x                    | x                    | x                    | x                    | x                    | x                    | x                    | x                    | x                    | x    |         |

## NOTES

1. Perform annually or at specified intervals, whichever comes first.
2. Should be performed by an authorized Harley-Davidson dealer, unless you have the proper tools, service data and are mechanically qualified.
3. Perform maintenance more frequently in severe riding conditions. This includes extreme temperatures, dusty environments, mountainous or rough roads, long storage conditions, short runs, heavy stop/go traffic or poor fuel quality.
4. Perform spoke tension check at 1,000 mi (2,000 km), 5,000 mi (8,000 km), 20,000 mi (32,000 km) services and every 15,000 mi (24,000 km) interval thereafter. Not all vehicles have spoked wheels. Consult appropriate topic in the service manual.
5. For torque instructions, see Shop Practices in the service manual.
6. Check for leaks, contact or abrasion.
7. Brake fluid level drops as brake pads wear.
8. Check coolant freeze point and inspect for leaks.
9. Use HARLEY LUBE.

## Lubricants, Greases, and Sealants

The below table lists common lubricants, greases, and sealants along with a corresponding part number and package size. Refer to Table 2-2.

Table 2-2. Lubricants, Greases, Sealants

| ITEM  | PART NUMBER    | PACKAGE           |
|---|----------------|-------------------|
| 3M 847 Adhesive                                       | 021200-19718 * | 5 oz tube         |
| 3M General Purpose Adhesive Remover                   |                | 15 oz aerosol     |
| Anti-Seize Lubricant                                  | 98960-97       | 1 oz squeeze tube |
| CCI #20 Brake Grease                                  | 42830-05       | squeeze packet    |
| DOT 4 Brake Fluid                                     | 99953-99A      | 12 oz bottle      |
| Dow Corning Moly 44 Grease                            | 94674-99       | 2 cc packet       |
| Electrical Contact Lubricant                          | 11300004       | 1 oz squeeze tube |
| Formula+ Transmission and Primary Chaincase Lubricant | 99851-05       | 1 qt bottle       |

**Table 2-2. Lubricants, Greases, Sealants**

| ITEM   | PART NUMBER     | PACKAGE                 |
|--|-----------------|-------------------------|
| G40M Brake Grease  | 42820-04        | squeeze packet          |
| Genuine Harley-Davidson Extended Life Antifreeze and Coolant     | 99822-02        | 1 gal container         |
| Genuine Harley-Davidson H-D 360 20W50 Motorcycle Oil             | 99816-2050/00QT | 1 qt bottle             |
| Harley-Davidson Adhesive (Griplock)                              | 99839-95        | 10 g tube               |
| Harley-Davidson High Performance Sealant - Gray                  | 99650-02        | 1.9 oz squeeze tube     |
| Harley-Davidson Leather Dressing                                 | 98261-91V       | 6 oz can                |
| Harley-Davidson Seal Grease                                      | 11300005        | 1 oz tube               |
| Harley Lube  | 94968-09        | 1/4 oz needle dispenser |
| Hylomar Gasket and Thread Sealant                                | 99653-85        | 3.0 oz tube             |
| Loctite 222 Low Strength Threadlocker and Sealant (purple)       | 99811-97        | 6 mL tube               |
| Loctite 243 Medium Strength Threadlocker and Sealant (blue)      | 99642-97        | 6 mL tube               |
|  | 11100005        | 50 mL bottle            |
| Loctite 246 Medium Strength/High Temperature Threadlocker (blue) |                 |                         |
| Loctite 262 High Strength Threadlocker and Sealant (red)         | 94759-99        | 6 mL tube               |
| Loctite 271 High Strength Threadlocker and Sealant (red)         |                 | 6 mL tube               |
|  | 11100006        | 50 mL bottle            |
| Loctite 411 Prism Instant Adhesive                               |                 |                         |
| Loctite 420 Super Bonder Adhesive                                |                 |                         |
| Loctite 565 Thread Sealant                                       | 99818-97        | 6 mL tube               |
| Loctite 770 Prism Primer   |                 |                         |
| Loctite 7649 Cleaner/Primer                                      | 98968-99        | 1.75 oz bottle          |
| PJ1 Super Cleaner  | 99878-87TA      | 13 oz aerosol can       |
| Screamin' Eagle Assembly Lube                                    | 11300002        | 4 oz tube               |
| Screamin' Eagle SYN3 Full Synthetic Motorcycle Lubricant 20W50   | 99824-03/00QT   | 1 qt bottle             |
| Special Purpose Grease   | 99857-97A       | 14 oz cartridge         |
| Type "E" Hydraulic Fork Oil                                      | 62600026        | 16 oz bottle            |
| Wheel Bearing Grease   | 99855-89        | 1 lb can                |
|  | 99856-92        | 14 oz cartridge         |

\* Not a Harley-Davidson part number

**FUEL**

Always use a good quality unleaded gasoline. Octane ratings are usually found on the pump. Refer to Table 2-3.

**A WARNING**

**Avoid spills. Slowly open fuel filler cap. Do not fill above bottom of filler neck insert, leaving air space for fuel expansion. Secure filler cap after refueling. Gasoline is extremely flammable and highly explosive, which could result in death or serious injury. (00028b)**

**A WARNING**

**Use care when refueling. Pressurized air in fuel tank can force gasoline to escape through filler tube. Gasoline is extremely flammable and highly explosive, which could result in death or serious injury. (00029a)**

Modern service station pumps dispense a high flow of gasoline into a motorcycle fuel tank. This can cause air entrapment and pressurization.

Table 2-3. Octane Rating

| SPECIFICATION       | RATING      |
|---------------------|-------------|
| Pump Octane (R+M)/2 | 91 (95 RON) |

**GASOLINE BLENDS**

Harley-Davidson motorcycles are designed to get the best performance and efficiency using unleaded gasoline. Most gasoline is blended with alcohol and/or ether to create oxygenated blends. The type and amount of alcohol or ether added to the fuel is important.

**NOTICE**

**Do not use gasoline that contains methanol. Doing so can result in fuel system component failure, engine damage and/or equipment malfunction. (00148a) <sup>1</sup>**

<sup>1</sup> Gasoline/METHYL TERTIARY BUTYL ETHER (MTBE) blends are a mixture of gasoline and as much as 15 percent MTBE. Gasoline/MTBE blends use in your motorcycle is approved.

- ETHANOL fuel is a mixture of ethanol (grain alcohol) and unleaded gasoline and can have an impact on fuel mileage. Fuels with an ethanol content of up to 10 percent may be used in your motorcycle without affecting vehicle performance. U.S. EPA regulations currently indicate that fuels with 15 percent ethanol (E15) are restricted from use in motorcycles at the time of this publication. Some motorcycles are calibrated to operate with higher ethanol concentrations to meet the fuel standards in certain countries.

- REFORMULATED OR OXYGENATED GASOLINES (RFG) describes gasoline blends that are specifically designed to burn cleaner than other types of gasoline. This results in fewer tailpipe emissions. They are also formulated to evaporate less when filling the tank. Reformulated gasolines use additives to oxygenate the gas. Your motorcycle will run normally using this type of fuel. Harley-Davidson recommends using it whenever possible as an aid to cleaner air in our environment.

- Do not use racing fuel or fuel containing methanol. Use of these fuels will damage the fuel system.

- Using fuel additives other than those approved for use by Harley-Davidson may damage the engine, fuel system and other components.

Some gasoline blends might adversely affect starting, performance or fuel efficiency. If any of these problems are experienced, try a different brand of gasoline or gasoline with a higher octane blend.

**ENGINE LUBRICATION**

**A CAUTION**

**Prolonged or repeated contact with used motor oil may be harmful to skin and could cause skin cancer. Promptly wash affected areas with soap and water. (00358b)**

**A CAUTION**

**If engine oil is swallowed, do not induce vomiting. Contact a physician immediately. In case of contact with eyes, immediately flush with water. Contact a physician if irritation persists. (00357d)**

**NOTICE**

**Do not switch lubricant brands indiscriminately because some lubricants interact chemically when mixed. Use of inferior lubricants can damage the engine. (00184a)**

Engine oil is a major factor in the performance and service life of the engine. Use the proper grade of oil for the lowest temperature expected before the next oil change. Refer to Table 2-4.

This motorcycle was originally equipped with GENUINE HARLEY-DAVIDSON H-D 360 MOTORCYCLE OIL 20W50. If operation under extreme cold or heat are expected, refer to Table 2-4 for alternative choices.

If H-D 360 or SYN3 is not available, add oil certified for diesel engines. Acceptable designations include: CH-4, CI-4 and CJ-4. The preferred viscosities, in descending order are: 20W50, 15W40 and 10W40.

At the first opportunity, see an authorized dealer to change back to 100 percent Harley-Davidson oil.

**Table 2-4. Recommended Engine Oils**

| TYPE   | VISCOSITY | LOWEST AMBIENT TEMPERATURE | COLD-WEATHER STARTS BELOW 50 °F (10 °C) |
|--|-----------|----------------------------|---|
| Screamin' Eagle SYN3 Full Synthetic Motorcycle Lubricant | SAE 20W50 | Above 30.2 °F (-1 °C)      | Excellent                               |
| Genuine Harley-Davidson H-D 360 Motorcycle Oil           | SAE 20W50 | Above 39.2 °F (4 °C)       | Good                                    |
| Genuine Harley-Davidson H-D 360 Motorcycle Oil           | SAE 50    | Above 60.8 °F (16 °C)      | Poor                                    |
| Genuine Harley-Davidson H-D 360 Motorcycle Oil           | SAE 60    | Above 80.6 °F (27 °C)      | Poor                                    |

**WINTER LUBRICATION**

Change engine oil often in colder climates. If motorcycle is frequently ridden less than 15 mi (24 km), in ambient temperatures below 60 °F (16 °C), reduce oil change intervals to 1500 mi (2,400 km).

***NOTE***

*Lower ambient temperatures require more frequent oil changes. Water vapor is a normal by-product of combustion . During cold-weather operation, some water vapor condenses to liquid form*

on the cool surfaces inside the engine. In freezing weather, this water becomes slush or ice. If the engine is not warmed to operating temperature, accumulated slush or ice blocks the oil lines and causes engine damage. Over time, water will accumulate, mix with the engine oil and form a sludge that is harmful to the engine.

If the engine is allowed to warm to normal operating temperature, most of the water evaporates and exits through the crankcase breather.

## CHECK ENGINE OIL LEVEL

### A CAUTION

Prolonged or repeated contact with used motor oil may be harmful to skin and could cause skin cancer. Promptly wash affected areas with soap and water. (00358b)

### NOTICE

Do not overfill oil. Doing so can result in oil carryover to the air cleaner leading to equipment damage and/or equipment malfunction. (00190b)

### NOTE

- Oil level can be checked with motorcycle upright or on jiffy stand. Both marks are on the same side of the dipstick. Carefully read dipstick when checking oil level.
- Check engine oil level at each complete fuel refill.

### Oil Level Cold Check

- Place vehicle on level ground resting on the jiffy stand.

### NOTE

Oil level on a cold engine should never be above the midway point.

- See Figure 2-1. Check engine oil level.
  - Remove filler plug/dipstick.
  - Wipe off the dipstick.
  - Insert the dipstick and tighten into the fill spout.
  - Remove filler plug/dipstick.
  - See Figure 2-2. Check oil level. The correct cold oil level is midway (2) between the ADD QT (1) and FULL HOT (3) marks on the dipstick.
- If oil level is at or below the ADD QT mark, add only enough oil to bring the level to the ADD QT mark.
- Start and idle engine on jiffy stand for two minutes. Turn off engine.
- Check oil level. Add only enough to bring level midway between the ADD QT (1) and FULL HOT (3).

### Oil Level Hot Check

### NOTICE

Do not allow hot oil level to fall below Add/Fill mark on dipstick. Doing so can result in equipment damage and/or equipment malfunction. (00189a)

### NOTE

Perform engine oil level hot check only with engine oil at normal operating temperature.

- Ride motorcycle until engine oil reaches at least 200 °F (93 °C) or higher.
- Allow engine to idle for 1-2 minutes on jiffy stand. Turn off engine.

- See Figure 2-1. Check oil level.
  - Remove filler plug/dipstick.
  - Wipe off the dipstick.
  - Insert the dipstick and tighten into the fill spout.
  - Remove filler plug/dipstick.
  - See Figure 2-2. Check oil level. Oil level must register between the ADD QT and FULL HOT marks on the dipstick.
- If oil level is at or below the ADD QT mark, add only enough oil to bring the level to the FULL HOT mark. Do not overfill.

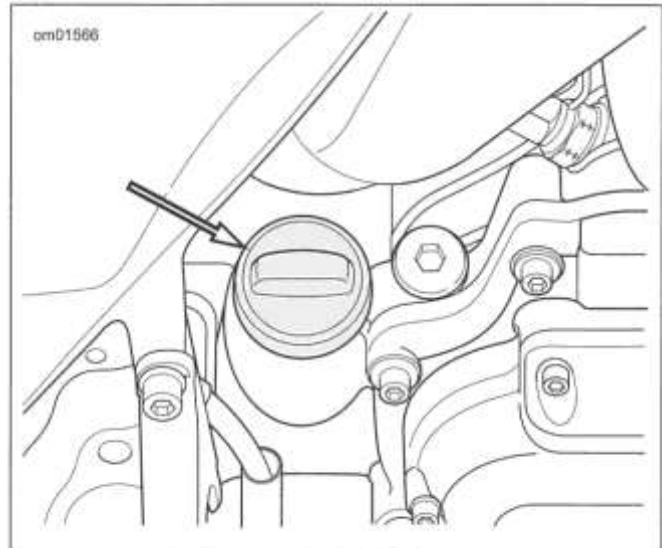


Figure 2-1. Engine Oil Filler Plug

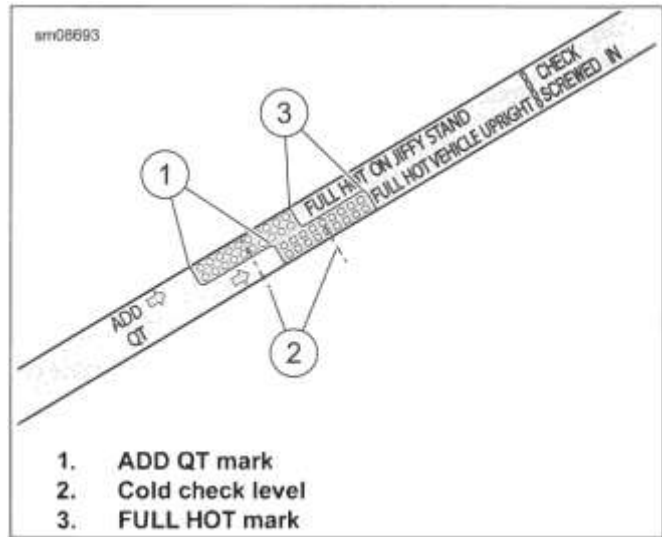


Figure 2-2. Engine Oil Dipstick

## CHANGE OIL AND OIL FILTER

| PART NUMBER | TOOL NAME         |
|-------------|-------------------|
| 94686-00    | OIL FILTER WRENCH |
| 94863-10    | OIL FILTER WRENCH |

| FASTENER              | TORQUE VALUE             |
|-----------------------|--------------------------|
| Engine oil drain plug | 14-21 ft-lbs 19-28.5 N-m |

**A WARNING**

Be sure that no lubricants or fluids get on tires, wheels or brakes when changing fluid. Traction can be adversely affected, which could result in loss of control of the motorcycle and death or serious injury. (00047d)

**NOTICE**

Do not switch lubricant brands indiscriminately because some lubricants interact chemically when mixed. Use of inferior lubricants can damage the engine. (00184a)

- Change engine oil at the first 1000 mi (1,600 km) for a **new** engine. After the initial service, change oil at regular intervals in normal service at warm or moderate temperatures. Refer to GENERAL (Page 2-3).
  - Change oil at more frequent intervals in cold weather or severe operating conditions. See FUEL AND OIL (Page 2-7).
1. Run motorcycle until engine is at normal operating temperature. Turn off engine.
  2. Remove filler plug/dipstick.

**NOTE**

Replace drain plug O-ring.

3. See Figure 2-3. Remove the oil drain plug (2) and O-ring. Allow oil to drain completely.

**NOTE**

Use P&A Oil Catcher (Part No. 62700199) or equivalent to keep drain oil off crankcase when removing oil filter. Residual drain oil could falsely appear as a crankcase oil leak at a later time.

4. Remove the oil filter using oil filter wrench and hand tools. Do not use with air tools.

Special Tool: OIL FILTER WRENCH (94863-10)

Special Tool: OIL FILTER WRENCH (94686-00)

5. Clean the oil filter mount flange.
6. Clean any residual oil for crankcase and transmission housing.
7. See Figure 2-4. Install **new** oil filter.
  - a. Lubricate gasket with a thin film of clean engine oil.
  - b. Install **new** oil filter.
  - c. Hand-tighten oil filter one-half to three-quarters of a turn after gasket first contacts filter mounting surface. Do NOT use oil filter wrench for installation.
8. Install engine oil drain plug and **new** O-ring.
 

Torque: 14-21 ft-lbs (19-28.5 N-m) *Engine oil drain plug*

**NOTE**

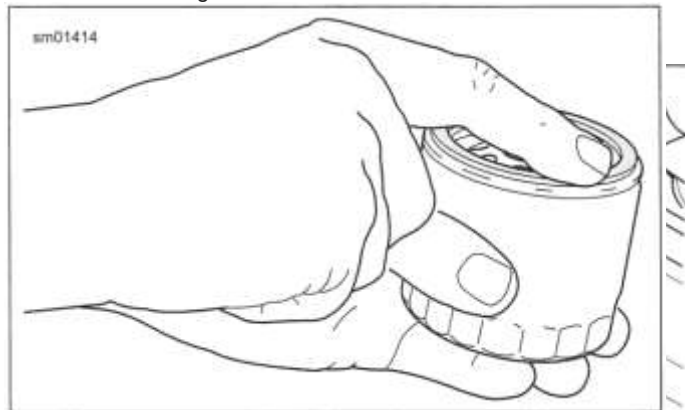
Use the proper grade of oil for the lowest temperature expected before the next oil change. Refer to Table 2-4 for recommended oil.

9. Add an initial volume of engine oil. Refer to Table 2-5.

**Table 2-5. Initial Oil Fill**

| ITEM                    | QUANTITY       |
|-------------------------|----------------|
| Engine oil initial fill | 4.0 qt (3.8 L) |

10. Verify proper oil level. See Check Engine Oil Level (Page 2-9).
  - a. Perform engine oil level **cold check**.
  - b. Start engine and carefully check for oil leaks around drain plug and oil filter.
  - c. Perform engine oil level **hot check**.

**Figure 2-4. Lubricating New Oil Filter Gasket**

**Figure 2-3. Oil Pan**  
 1. Transmission drain plug (left side)  
 2. Engine oil drain plug and O-ring  
 3. Hex plug (do not remove)

## CHANGE PRIMARY CHAINCASE LUBRICANT

| FASTENER                       | TORQUE VALUE  |              |
|--------------------------------|---------------|--------------|
| Clutch inspection cover screws | 84-108 in-lbs | 9.5-12.2 N-m |
| Primary chaincase drain plug   | 14-21 ft-lbs  | 19-28.5 N-m  |

1. Run motorcycle until engine is at normal operating temperature. Turn off engine.

**A WARNING**

Be sure that no lubricants or fluids get on tires, wheels or brakes when changing fluid. Traction can be adversely affected, which could result in loss of control of the motorcycle and death or serious injury. (00047d)

2. Secure motorcycle upright (not leaning on jiffy stand) on a level surface.
3. See Figure 2-5. Drain primary chaincase.
4. Clean drain plug magnet. If plug has excessive debris, inspect the condition of chaincase components.
5. Install drain plug and new O-ring. Tighten.

Torque: 14-21 ft-lbs (19-28.5 N-m) *Primary chaincase drain plug*

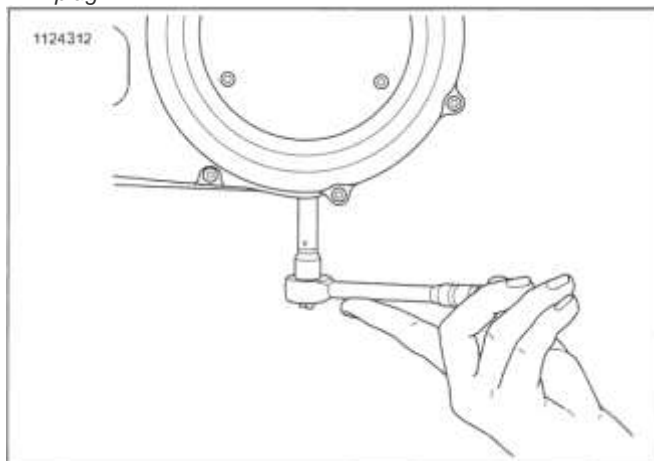


Figure 2-5. Removal/Installation of Chaincase Drain Plug

6. See Figure 2-7. Remove screws (3) and clutch inspection cover (2).
7. Remove seal (1). Wipe oil from groove in chaincase cover and mounting surface.

**NOTICE**

Do not overfill the primary chaincase with lubricant. Overfilling can cause rough clutch engagement, incomplete disengagement, clutch drag and/or difficulty in finding neutral at engine idle. (00199b)

8. Add lubricant.
  - a. Pour specified amount of FORMULA+ TRANSMISSION AND PRIMARY CHAINCASE LUBRICANT or SCREAMIN' EAGLE SYN3 FULL SYNTHETIC MOTORCYCLE LUBRICANT 20W50 through clutch inspection cover opening. Refer to Table 2-6.
  - b. See Figure 2-6. Proper level is approximately at bottom of pressure plate OD.

Table 2-6. Primary Chaincase Lubricant

| ITEM    | DRY FILL** |     | WET FILL*** |     |
|---------|------------|-----|-------------|-----|
|         | Oz         | L   | Oz          | L   |
| Amount* | 34         | 1.0 | 30          | 0.9 |

\* Amount is approximate. Fill to bottom of pressure plate OD with vehicle upright.

\*\* Cover was removed and installed.

\*\*\* Lubricant was drained through the drain plug only.

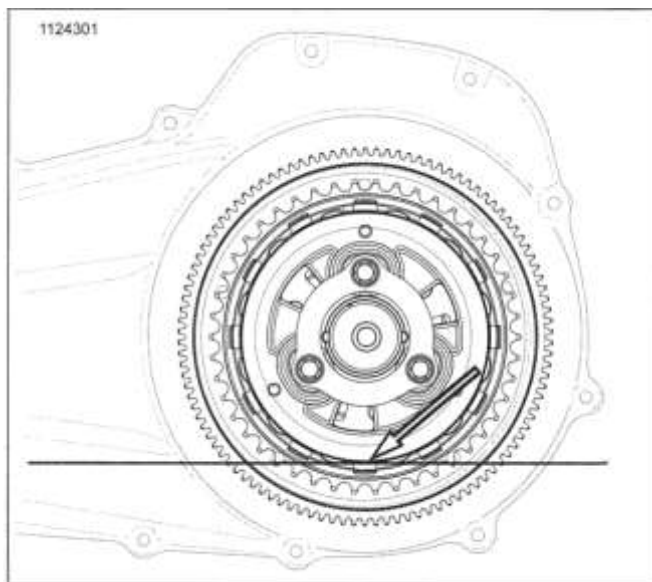
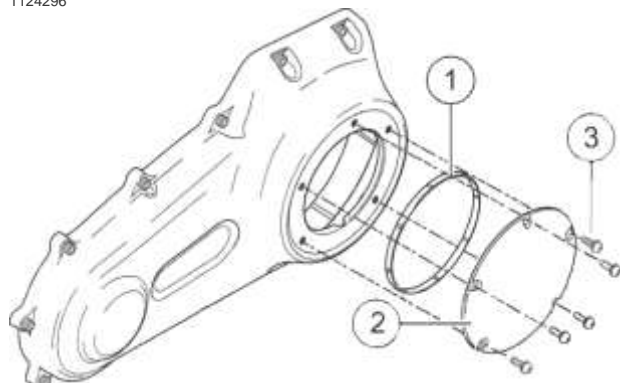


Figure 2-6. Primary Lubricant Level

9. Install clutch inspection cover and new seal:
  - a. Thoroughly wipe all lubricant from cover mounting surface and groove in chaincase cover.
  - b. See Figure 2-7. Position new seal (1) in groove in clutch inspection cover (2). Press each of the nubs on seal into the groove.
  - c. Secure clutch inspection cover (2) with screws with captive washers (3).
  - d. See Figure 2-8. Tighten in sequence shown to 84-108 in-lbs (9.5-12.2 N-m).



- 1. Seal
  - 2. Clutch inspection cover
  - 3. Screw and captive washer (5)
- Figure 2-7. Clutch Cover (Typical)

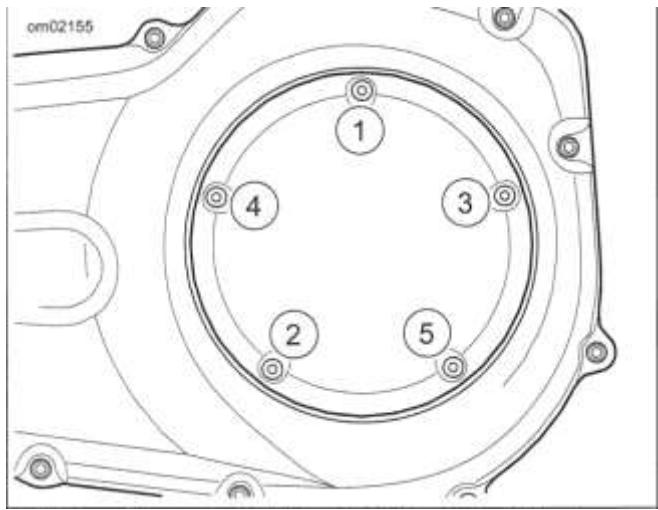


Figure 2-8. Clutch Cover Tightening Sequence



## CHECK TRANSMISSION LUBRICANT

| FASTENER                          | TORQUE VALUE |             |
|-----------------------------------|--------------|-------------|
| Transmission filler plug/dipstick | 25-75 in-lbs | 2.8-8.5 N-m |

**NOTE**

Check transmission fluid with the motorcycle at ambient temperature. Inspect transmission dipstick O-ring. Replace if necessary.

1. Park motorcycle on a level surface on jiffy stand.
2. See Figure 2-9. Remove transmission filler plug/dipstick. Wipe dipstick clean.
3. Install filler plug/dipstick until O-ring contacts the case. Do not tighten.
4. See Figure 2-10. Remove filler plug/dipstick. Check lubricant level on dipstick. Proper oil level is between the Add (A) (1) and Full (F) (2) marks.
5. If lubricant level is low, add recommended Harley-Davidson lubricant to bring level to between the A mark and the F marks. Refer to Table 2-7.
6. Install filler plug/dipstick. Tighten to specification.

Torque: 25-75 in-lbs (2.8-8.5 N-m) *Transmission filler plug/dipstick*

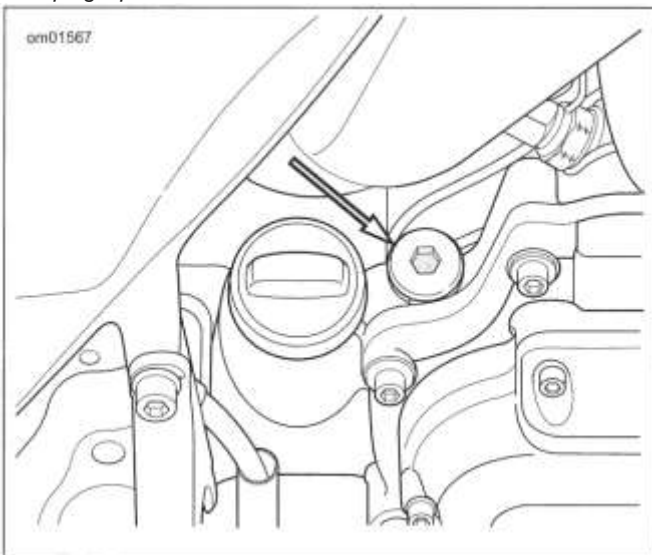


Figure 2-9. Transmission Filler Plug/Dipstick Location

**A WARNING**

Be sure that no lubricants or fluids get on tires, wheels or brakes when changing fluid. Traction can be adversely affected, which could result in loss of control of the motorcycle and death or serious injury. (00047d)

2. See Figure 2-11. Remove transmission drain plug. Drain transmission.
3. Clean and inspect drain plug and O-ring.

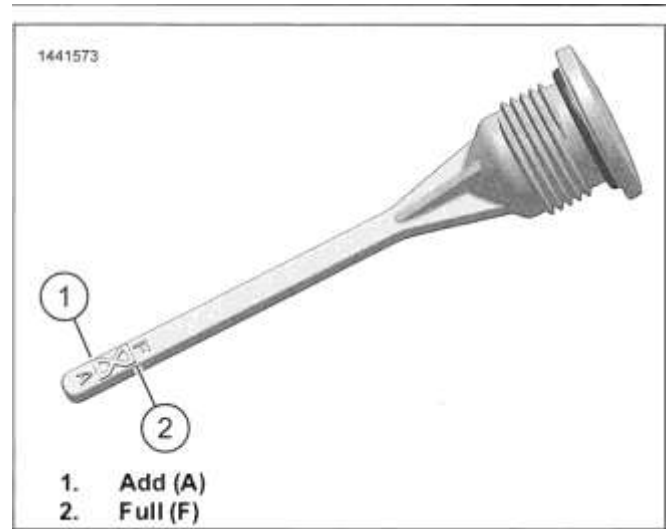


Figure 2-10. Transmission Lubricant Level

Table 2-7. Transmission Lubricant

| MODEL | LUBRICANT   |
|-------|---|
| All   | FORMULA+ TRANSMISSION AND PRIMARY CHAIN LUBRICANT or SCREAMIN' EAGLE SYN3 FULL SYNTHETIC MOTORCYCLE LUBRICANT 20W50 |

## CHANGE TRANSMISSION LUBRICANT

| FASTENER                          | TORQUE VALUE |             |
|-----------------------------------|--------------|-------------|
| Transmission drain plug           | 14-21 ft-lbs | 19-28.5 N-m |
| Transmission filler plug/dipstick | 25-75 in-lbs | 2.8-8.5 N-m |

1. See Figure 2-9. Remove transmission filler plug/dipstick. Do not over-tighten filler or drain plug. Doing so could result in a lubricant leak. (00200b)
4. Install drain plug with new O-ring. Tighten. Do not over-tighten.  
Torque: 14-21 ft-lbs (19-28.5 N-m) *Transmission drain plug*
5. Fill the transmission to specification with recommended Harley-Davidson lubricant. Refer to Table 2-7.  
Volume: 28 fl oz (0.83 L)

**NOTICE**

6. Check lubricant level. Add enough lubricant to bring the level between the add (A) and full (F) marks. See Figure 2-10.

7. Install filler plug/dipstick. Tighten.

Torque: 25-75 in-lbs (2.8-8.5 N-m) *Transmission filler plug/dipstick*

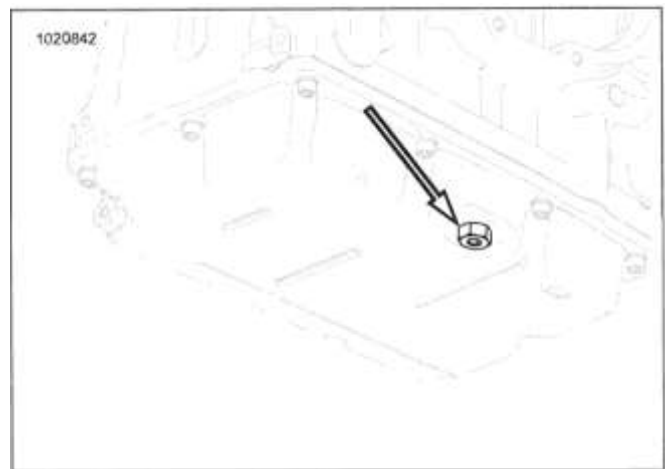


Figure 2-11. Transmission Drain Plug

## GENERAL

### A WARNING

reach the tread wear indicators.

Match tires, tubes, rim strips or seals, air valves and caps to the correct wheel. Contact a Harley-Davidson dealer. Mismatching can lead to tire damage, allow tire slippage on the wheel or cause tire failure, which could result in death or serious injury. (00023c)

### A WARNING

Harley-Davidson front and rear tires are not the same. Interchanging front and rear tires can cause tire failure, which could result in death or serious injury. (00026a)

#### NOTE

- Tubeless tires are used on all Harley-Davidson cast wheels.
- Tire sizes are molded on the tire sidewall. Inner tube sizes are printed on the tube.
- Store **new** tires on a horizontal tire rack. Avoid stacking **new** tires in a vertical stack. The weight of the stack compresses the tires and crushes the beads.

## Tire Pressure

### A WARNING

Be sure tires are properly inflated, balanced, undamaged, and have adequate tread. Inspect your tires regularly and see a Harley-Davidson dealer for replacements. Riding with excessively worn, unbalanced, improperly inflated, overloaded or damaged tires can lead to tire failure and adversely affect stability and handling, which could result in death or serious injury. (00014b)

Check tire pressure:

- As part of the pre-ride checklist.
  - At every scheduled service interval.
1. Check tire pressures when tires are cold. Compare with specifications. Refer to Table 2-8.

#### NOTE

Harley-Davidson does not perform any testing with only nitrogen in tires. Harley-Davidson neither recommends nor discourages the use of pure nitrogen to inflate tires.

## Tread

### A WARNING

Replace tire immediately with a Harley-Davidson specified tire when wear bars become visible or only 1/32 in (1 mm) tread depth remains. Riding with a worn tire could result in death or serious injury. (00090c)

Check tire tread:

- As part of the pre-ride checklist.
  - At every scheduled service interval.
1. Inspect each tire for punctures, cuts and breaks.

2. See Figure 2-12, Figure 2-13 and Figure 2-14. Inspect each tire for wear. Replace tires before they

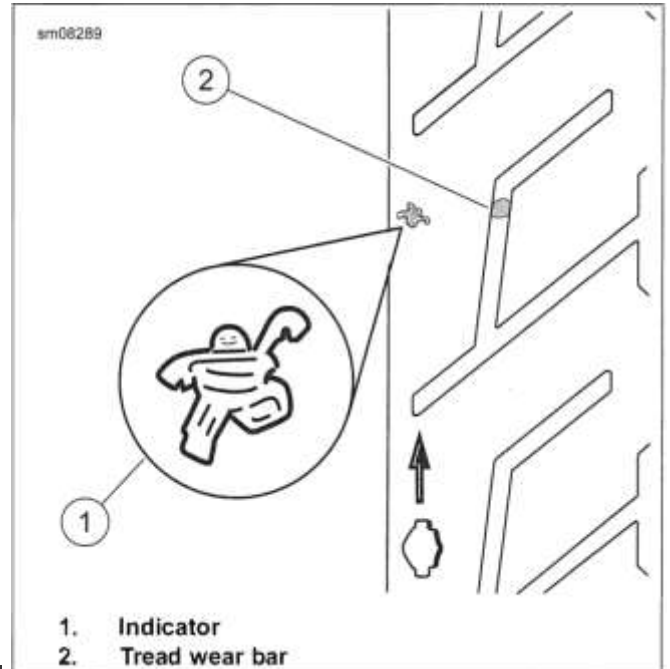


Figure 2-12. Tread Wear Indicator: Michelin Tires

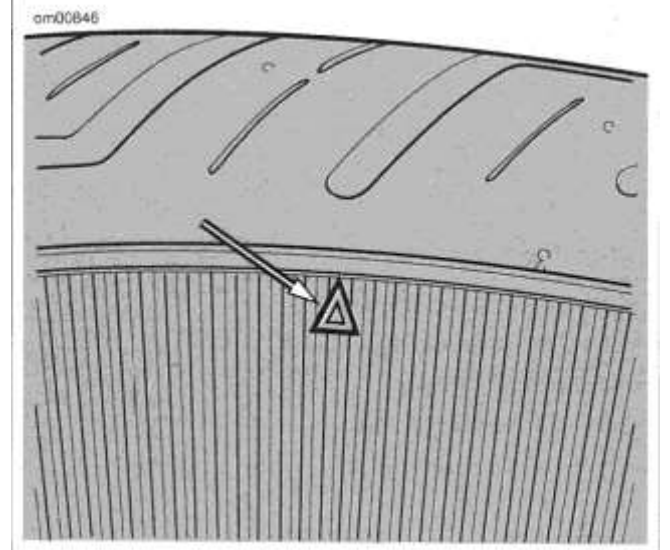


Figure 2-13. Dunlop Sidewall Tread Wear Indicator Bar Locator

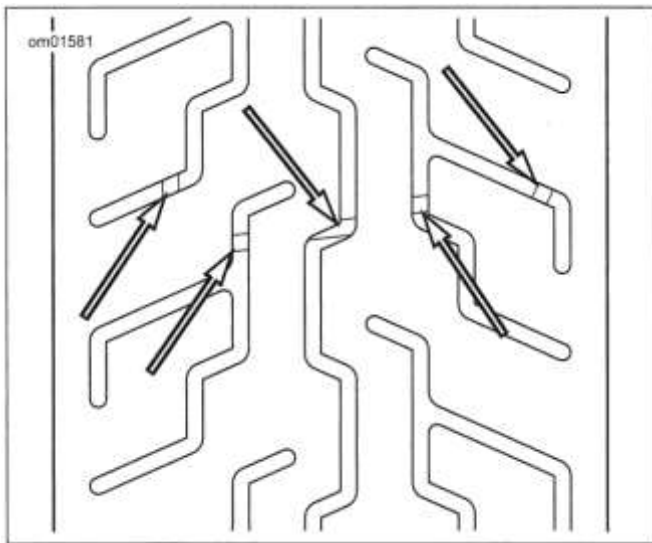


Figure 2-14. Dunlop Tread Wear Indicator Bar Appearance

## When to Replace Tires

New tires are needed if:

- Tread wear indicators become visible on the tread surfaces.
- Tire cords or fabric become visible through cracked sidewalls, snags or deep cuts.
- A bump, bulge or split in the tire.
- A puncture, cut or other damage to the tire that cannot be repaired.

Table 2-8. Specified Tires

| MODEL                                | MOUNT | SIZE  | SPECIFIED TIRE                | PRESSURE (COLD<br>68 °F (20 °C)) |     |
|--------------------------------------|-------|-------|-------------------------------|----------------------------------|-----|
|                                      |       |       |                               | psi                              | kPa |
| Revival™ (FLH)                       | front | 16 in | Dunlop D402F MT90B16 72H WW   | 36                               | 248 |
| Electra Glide® Standard (FLHT)       | front | 17 in | Dunlop D408F 130/80B17 65H BW | 36                               | 248 |
| Electra Glide® Ultra Limited (FLHTK) | front | 18 in | Dunlop D408F 130/70B18 63H BW | 36                               | 248 |
| Road Glide® Limited (FLTRK)          |       |       |                               |                                  |     |
| Road King® (FLHR)                    |       |       |                               |                                  |     |
| Road Glide® (FLTRX)                  | front | 19 in | Dunlop D408F 130/60B19 61H BW | 36                               | 248 |
| Road Glide® Special (FLTRXS)         |       |       |                               |                                  |     |
| Road King® Special (FLHRXS)          |       |       |                               |                                  |     |
| Street Glide® (FLHX)                 |       |       |                               |                                  |     |
| Street Glide® Special (FLHXS)        |       |       |                               |                                  |     |
| Revival™ (FLH)                       | rear  | 16 in | Dunlop D407T 180/65B16 81H WW | 40                               | 276 |
| Electra Glide® Standard (FLHT)       | rear  | 16 in | Dunlop D407T 180/65B16 81H BW | 40                               | 276 |
| Electra Glide® Ultra Limited (FLHTK) | rear  | 18 in | Dunlop D407T 180/55B18 80H BW | 40                               | 276 |
| Road Glide® (FLTRX)                  |       |       |                               |                                  |     |
| Road Glide® Limited (FLTRK)          |       |       |                               |                                  |     |
| Road Glide® Special (FLTRXS)         |       |       |                               |                                  |     |
| Road King® (FLHR)                    |       |       |                               |                                  |     |
| Road King® Special (FLHRXS)          |       |       |                               |                                  |     |
| Street Glide® (FLHX)                 |       |       |                               |                                  |     |
| Street Glide® Special (FLHXS)        |       |       |                               |                                  |     |

## TIRES

### Inspect

Tread wear indicators appear on tire tread surfaces when 0.031 in (0.8 mm) or less of tire tread remains. Always replace tires before the tread wear indicators appear on the surface of the tire.

See Figure 2-12 or Figure 2-13 . The locations of tread wear indicators are identified by the marks on the tire sidewalls.

## WHEEL BEARINGS

### NOTE

Replace bearings in sets only See SEALED WHEEL BEARINGS (Page 3-26).

1. Replace when bearings exceed end play service wear limit of 0.002 in (0.051 mm).
2. Inspect any time the wheels are removed.
  - a. Inspect the play of the wheel bearings by hand while they are in the wheel.
  - b. Rotate the inner bearing race and check for abnormal noise.
  - c. Make sure that bearing rotates smoothly.
3. Check wheel bearings and axle spacers for wear and corrosion. Excessive play or roughness indicates worn bearings.

| PART NUMBER | TOOL NAME           |
|-------------|---------------------|
| HD-48985    | SPOKE TORQUE WRENCH |
| HD-94681-80 | SPOKE WRENCH        |

| FASTENER     | TORQUE VALUE |         |
|--------------|--------------|---------|
| Spoke nipple | 55 in-lbs    | 6.2 N-m |

### A WARNING

## WHEEL SPOKES

Spokes that are too tight can draw nipples through the rim or distort hub flanges. Spokes that are too loose can continue to loosen when put in service. Either condition can adversely affect stability and handling, which could result in death or serious injury. (00286a)

### A WARNING

Do not over-tighten spoke nipples. Protruding spoke nipples can damage rim seal, resulting in rapid tire deflation, which could cause death or serious injury. (00611c)

### NOTICE

When lifting a motorcycle using a jack, be sure jack contacts both lower frame tubes where down tubes and lower frame tubes converge. Never lift by jacking on cross-members, oil pan, mounting brackets, components or housings. Failure to comply can cause serious damage resulting in the need to perform major repair work. (00586d)

## Identify Wheel Spoke Groups

### NOTE

Spokes are grouped in sets of four.

1. Raise the wheel.
2. See Figure 2-15. Starting at the valve stem, identify the first group of four spokes (1-4).
3. Using a different color for each spoke in the group, draw an alignment mark across the spoke nipple and onto the rim.

4. Continue around the wheel marking the rest of the spokes the same as they were marked in the previous steps.

## Adjust Wheel Spokes

### NOTE

- Do not tighten spoke more than one-quarter turn past alignment mark. If more tension is needed, label spoke and check after completing rest of wheel.
- Do not use the spoke torque wrench to loosen spokes. Use SPOKE WRENCH (PART NUMBER: HD-94681-80) to loosen spokes.

1. See Figure 2-15. Starting with the first group of spokes, loosen spoke (1) one-quarter turn using SPOKE WRENCH (PART NUMBER: HD-94681-80).
2. Using SPOKE TORQUE WRENCH (PART NUMBER: HD-48985) tighten spoke (1) to the value listed in Table 2-9.
  - a. While tightening, if the torque wrench clicks before the alignment marks align, continue to turn the spoke nipple until the marks align.
  - b. If the marks align and torque specification has not been reached, tighten the spoke nipple until the correct torque is achieved. Do not turn spoke nipple more than one-quarter turn past alignment mark.
3. Repeat previous two steps for spoke (4) in the same group.
4. Continue around the wheel checking spokes 1 and 4 until all groups are done.
5. Repeat procedure for spokes (2, 3) in each group.

### NOTE

When checking any spokes that were labeled, make sure to use the original alignment mark.

6. Check spokes, if any, that were labeled as not reaching the proper torque value after tightening one-quarter turn past alignment mark.
  - a. Loosen spoke one-quarter turn past original alignment mark using SPOKE WRENCH (PART NUMBER: HD-94681-80).
  - b. While tightening, if the torque wrench clicks before the alignment marks align, continue to turn the spoke nipple until the marks align.
  - c. If the marks align and torque specification has not been reached, tighten the spoke nipple until the correct torque is achieved. Do not turn spoke nipple more than one-quarter turn past alignment mark.

7. True the wheel. See CHECKING AND TRUING WHEELS (Page 3-22).

Table 2-9. Spoke Nipple Torque Specification

| RIM TYPE | MINIMUM TORQUE      |
|----------|---------------------|
| All      | 55 in-lbs (6.2 N-m) |

## GENERAL

Inspect and lubricate the following items according to MAINTENANCE SCHEDULE (Page 2-4).

If service is on muddy or dusty roads, clean and lubricate at shorter intervals.

## LUBRICATION POINTS

Inspect and lubricate the following components according to the maintenance schedule. Refer to MAINTENANCE SCHEDULE (Page 2-4).

- Front brake lever pivot
- Clutch control hand lever pivot
- Foot shift lever pivot
- Rear brake lever pivot
- Hinges and latches (such as fuel door and footrests)
- Locks, as required
- Jiffy stand (use ANTI-SEIZE LUBRICANT)  
Use HARLEY LUBE unless otherwise specified.

If motorcycle is operated on muddy or dusty roads, clean and lubricate more frequently.

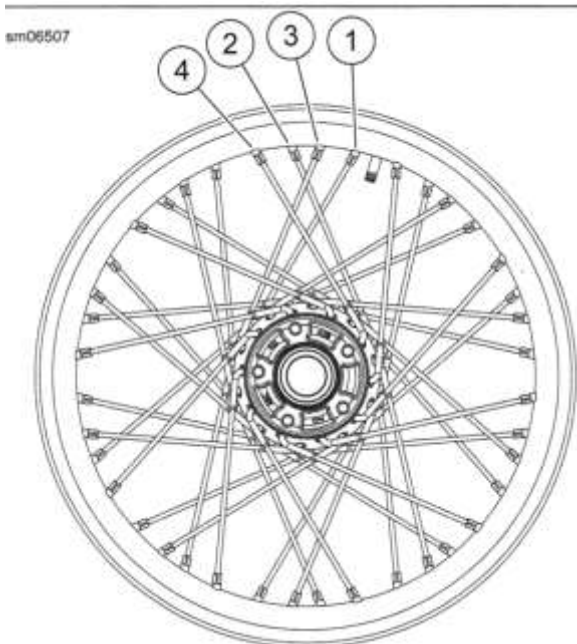


Figure 2-15. Tightening Laced Wheels (typical)

**INSPECT**

| PART NUMBER | TOOL NAME                         |
|-------------|-----------------------------------|
| HD-48497-A  | DOT 4 BRAKE FLUID MOISTURE TESTER |
| PART NUMBER | CONSUMABLE                        |
| 41800219    | DOT 4 BRAKE FLUID                 |

**NOTICE**

Do not allow dirt or debris to enter the master cylinder reservoir. Dirt or debris in the reservoir can cause improper operation and equipment damage. (00205c)

**NOTE**

- At every service, check moisture content of fluid using DOT 4 BRAKE FLUID MOISTURE TESTER (PART NUMBER: HD-48497-A). Follow the instructions included with tool.
- Flush brake system and replace DOT 4 BRAKE FLUID (41800219) fluid every two years or sooner if brake fluid test shows moisture content is 3% or greater.
- Fluid should never need to be added or removed from the system during normal wear, except for fluid replacement as specified in the maintenance schedule.
- Fluid level in reservoir will decrease with brake wear. Reservoir volume is adequate to provide fluid to the wear limits of the pads and rotors.

Check brake pads and discs:

- At every scheduled service interval.
- When removed during service procedures.

**NOTE**

When checking the brake pads and discs, inspect the brake hoses for correct routing and any signs of damage.

**Brake Pads****A WARNING**

Always replace brake pads in complete sets for correct and safe brake operation. Improper brake operation could result in death or serious injury. (00111a)

**A WARNING**

Contact with DOT 4 brake fluid can have serious health effects. Failure to wear proper skin and eye protection could result in death or serious injury.

- If inhaled: Keep calm, remove to fresh air, seek medical attention.
- If on skin: Remove contaminated clothing. Rinse skin immediately with plenty of water for 15-20 minutes. If irritation develops, seek medical attention.
- If in eyes: Wash affected eyes for at least 15 minutes under running water with eye lids held open. If irritation develops, seek medical attention.
- If swallowed: Rinse mouth and then drink plenty of water. Do not induce vomiting. Contact Poison Control. Immediate medical attention required.
- See Safety Data Sheet (SDS) for more details available at [sds.harley-davidson.com](http://sds.harley-davidson.com)

(00240e)

**NOTICE**

DOT 4 brake fluid will damage painted and body panel surfaces it comes in contact with. Always use caution and protect surfaces from spills whenever brake work is performed. Failure to comply can result in cosmetic damage. (00239c)

- Inspect for grit and debris buildup at caliper piston areas. Clean if necessary.
  - Rinse area with warm soapy water.
  - Dry using low-pressure compressed air.

2.

**NOTE**

Always replace both pads in a caliper as a set.

See Figure 2-16. Measure brake pad thickness.

- Replace brake pads (3) if friction material thickness is equal to or less than dimension.
  - 016 in (0.4 mm)
- See INSPECT BRAKES (Page 2-19).

**Brake Disc****NOTE**

Minimum acceptable thickness is stamped on side of disc.

- Measure thickness.
  - Measure thickness with a micrometer.
  - Replace disc if disc is scored or measured thickness is less minimum.

2. Measure runout.

- a. Measure runout near the outside diameter of the disc using a dial indicator.
- b. Replace disc if runout meets or exceeds dimension.
  0. .008 in (0.2 mm)

Replace disc if warped, badly scored or worn beyond service limit. See FRONT WHEEL (Page 3-12) or REAR WHEEL (Page 3-14).

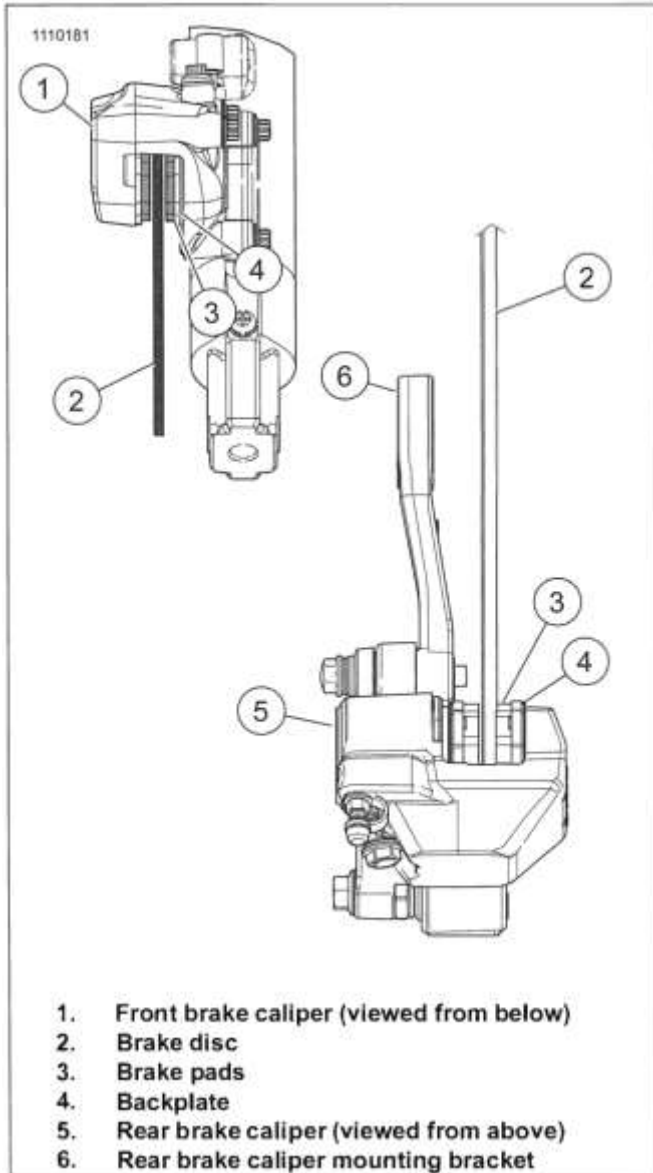


Figure 2-16. Brake Pad Inspection

**REPLACE FRONT BRAKE PADS**

| FASTENER      | TORQUE VALUE                 |
|---------------|------------------------------|
| Brake pad pin | 75-102 in-lbs 1 8.5-11.5 N-m |

**Remove**

1. Remove caliper. See FRONT BRAKE CALIPER (Page 3-40).

2. **NOTE**

*Do not operate the brakes with the brake caliper removed. The caliper pistons can be forced out.*

Loosen master cylinder reservoir cap. See FRONT BRAKE MASTER CYLINDER (Page 3-37).

3. Remove grit and debris from caliper piston area.

- a. Rinse area with warm soapy water.
- b. Dry using low-pressure compressed air.

4. **NOTE**

*As pistons are pushed back into the caliper, fluid level may overflow reservoir. Remove fluid from reservoir if necessary*

See Figure 2-17. Remove pads

- a. Remove screen (3) from caliper.
- b. Using the old brake pad and a C-clamp, retract the pistons fully into the caliper.
- c. Remove retaining clip (4).
- d. Discard pad pin (5) (metric).
- e. Remove brake pads.
- f. Inspect pad spring (7). Replace if needed.

**Install**

**A WARNING**

**Always replace brake pads in complete sets for correct and safe brake operation. Improper brake operation could result in death or serious injury. (00111a)**

1. See Figure 2-17. Install pad spring (7). Replace if removed.
  - a. Install on flat in caliper so clips on spring engage indentations in caliper.
  - b. Make sure that forked end is on pad pin side of caliper.
2. Install **new** brake pads.
  - a. See Figure 2-18. Insert each brake pad with square corner (1) in slot of caliper.
  - b. Push pad pin tab (2) into caliper.
  - c. See Figure 2-17. Install **new** pad pin. Tighten. Torque: 75-102 in-lbs (8.5-11.5 N-m) *Brake pad pin*
  - d. Install clip (4).
  - e. Install screen (3). Engage prongs of screen on forked end of pad spring (7). Push on opposite side of screen until engaged.



3. Tighten master cylinder reservoir cap. See FRONT BRAKE MASTER CYLINDER (Page 3-37).
4. Install caliper. See FRONT BRAKE CALIPER (Page 3-40).
5. Pump brakes to move pistons out until brake pads contact rotor. Verify piston location against pads. If front wheel is off the ground, rotate wheel to check for excessive brake pad drag.
6. Check fluid level in brake master cylinder reservoir. See CHECK AND REPLACE BRAKE FLUID (Page 2-24).

**A WARNING**

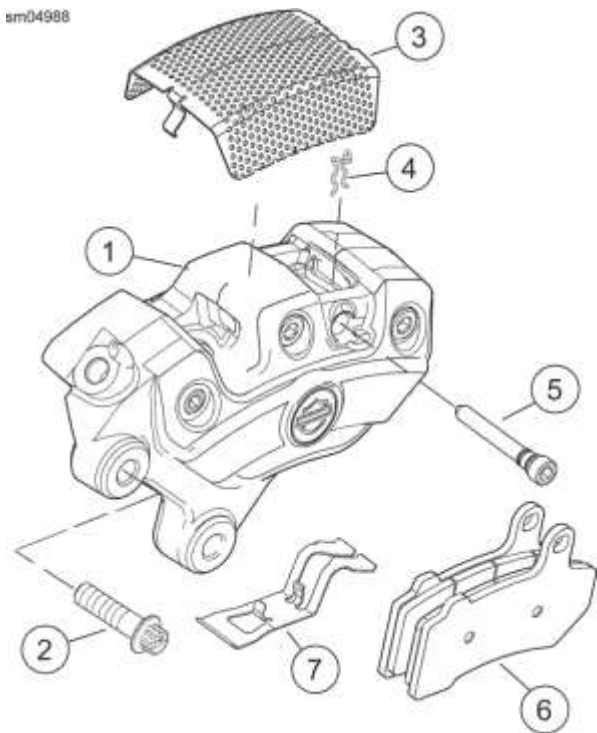
After repairing the brake system, test brakes at low speed. If brakes are not operating properly, testing at high speeds can cause loss of control, which could result in death or serious injury. (00289a)

7. **NOTE**  
 Avoid making hard stops for the first 100mi (160 km) in order to wear in the brakes properly.

Test brakes.

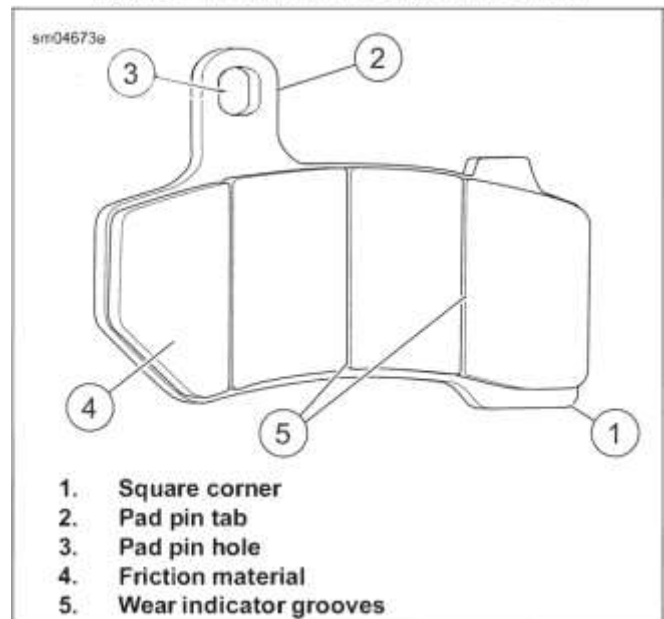
- a. Turn ignition switch ON. Check operation of rear lamps.
- b. Test ride motorcycle. If brakes feel spongy, bleed brakes. See CHECK AND REPLACE BRAKE FLUID (Page 2-24).

sm04988



1. Caliper
2. Caliper mounting screw (2)
3. Screen
4. Retaining clip
5. Pad pin
6. Brake pads
7. Pad spring

**Figure 2-17. Front Brake Caliper Assembly**



**Figure 2-18. Brake Pad**

**REPLACE REAR BRAKE PADS**

| FASTENER      | TORQUE VALUE  |              |
|---------------|---------------|--------------|
| Brake pad pin | 75-102 in-lbs | 8.5-11.5 N-m |

**Remove**

1. Remove caliper. See FRONT BRAKE CALIPER (Page 3-40).

2. **NOTE**  
Do not operate the brakes with the brake caliper removed. The caliper pistons can be forced out.

Loosen master cylinder reservoir cap. See FRONT BRAKE MASTER CYLINDER (Page 3-37).

3. Remove grit and debris from caliper piston area.
  - a. Rinse area with warm soapy water.
  - b. Dry using low-pressure compressed air.

4. **NOTE**  
As pistons are pushed back into the caliper, fluid level may overflow reservoir. Remove fluid from reservoir if necessary

See Figure 2-19. Remove pads

- a. Using the old brake pad and a C-clamp, retract the pistons fully into the caliper.
- b. Remove retaining clip (4).
- c. Discard pad pin (5) (metric).
- d. Remove brake pads.
- e. Inspect pad spring (7). Replace if needed.

## Install

### A WARNING

Always replace brake pads in complete sets for correct and safe brake operation. Improper brake operation could result in death or serious injury. (00111a)

1. See Figure 2-19. Install pad spring (7). Replace if removed.
  - a. Install on flat in caliper so clips on spring engage indentations in caliper.
  - b. Make sure that forked end is on pad pin side of caliper.
2. Install new brake pads.
  - a. Apply paste supplied in kit to back of brake pads.
  - b. See Figure 2-20. Insert each brake pad with square corner (1) in slot of caliper.
  - c. Push pad pin tab (2) into caliper.
  - d. See Figure 2-19. Install new pad pin. Tighten.  
Torque: 75-102 in-lbs (8.5-11.5 N-m) *Brake pad pin*
  - e. Install clip (4).
3. Tighten front master cylinder reservoir cap. See FRONT BRAKE MASTER CYLINDER (Page 3-37).

4. Install caliper. See FRONT BRAKE CALIPER (Page 3-40).
5. Pump brakes to move pistons out until brake pads contact rotor. Verify piston location against pads.
6. Check fluid level in brake master cylinder reservoir. See CHECK AND REPLACE BRAKE FLUID (Page 2-24).

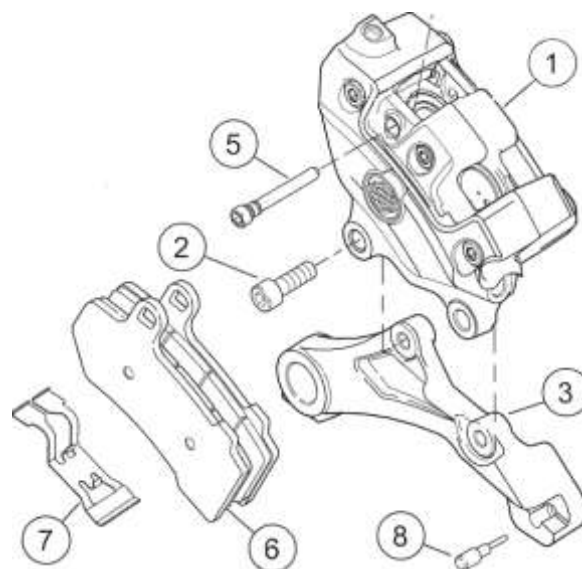
### A WARNING

After repairing the brake system, test brakes at low speed. If brakes are not operating properly, testing at high speeds can cause loss of control, which could result in death or serious injury. (00289a)

7. **NOTE**  
Avoid making hard stops for the first 100mi (160 km) in order to wear in the brakes properly

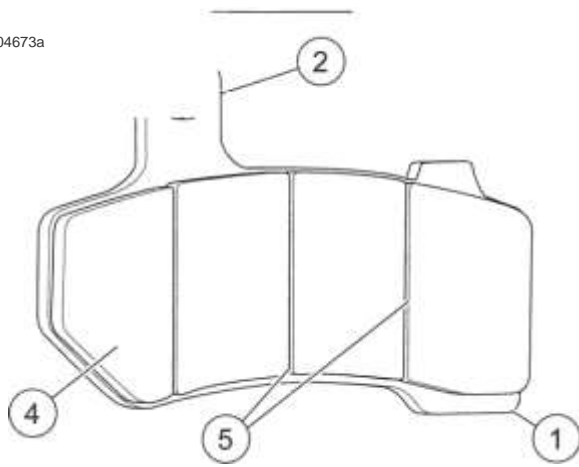
Test brakes.

- a. Turn ignition switch ON. Check operation of rear lamps.
- b. Test ride motorcycle. If brakes feel spongy, bleed brakes. See CHECK AND REPLACE BRAKE FLUID (Page 2-24).



1. Caliper
2. Caliper bracket screw (2)
3. Caliper bracket
4. Retaining clip
5. Pad pin
6. Brake pads
7. Pad spring
8. Rubber bumper
9. Bleeder screw
10. Bleeder screw cap

Figure 2-19. Rear Brake Caliper Assembly



- 1. Square corner
- 2. Pad pin tab
- 3. Pad pin hole
- 4. Friction material
- 5. Wear indicator grooves

Figure 2-20. Brake Pad

## CHECK BRAKE FLUID LEVEL

| PART NUMBER | TOOL NAME                         |
|-------------|-----------------------------------|
| HD-48497-A  | DOT 4 BRAKE FLUID MOISTURE TESTER |

### A WARNING

Clean reservoir filler cap or cover before removing. Use only DOT 4 brake fluid from a sealed container. Contaminated fluid can adversely affect braking or clutch disengagement, which could result in death or serious injury. (00504d)

### A WARNING

Contact with DOT 4 brake fluid can have serious health effects. Failure to wear proper skin and eye protection could result in death or serious injury.

- If inhaled: Keep calm, remove to fresh air, seek medical attention.
- If on skin: Remove contaminated clothing. Rinse skin immediately with plenty of water for 15-20 minutes. If irritation develops, seek medical attention.
- If in eyes: Wash affected eyes for at least 15 minutes under running water with eye lids held open. If irritation develops, seek medical attention.
- If swallowed: Rinse mouth and then drink plenty of water. Do not induce vomiting. Contact Poison Control. Immediate medical attention required.
- See Safety Data Sheet (SDS) for more details available at [sds.harley-davidson.com](http://sds.harley-davidson.com)

(00240e)

### NOTICE

DOT 4 brake fluid will damage painted and body panel surfaces it comes in contact with. Always use caution and protect surfaces from spills whenever brake work is performed. Failure to comply can result in cosmetic damage. (00239c)

### NOTICE

Do not allow dirt or debris to enter the master cylinder reservoir. Dirt or debris in the reservoir can cause improper operation and equipment damage. (00205c)

### NOTE

- *At every service, check moisture content of fluid using DOT 4 BRAKE FLUID MOISTURE TESTER (PART NUMBER: HD-48497-A). Follow the instructions included with tool.*
- *Flush brake system and replace DOT4 fluid every two years or sooner if brake fluid test shows moisture content is 3% or greater.*
- *Fluid should never need to be added or removed from the system during normal wear, except for fluid replacement as specified in the maintenance schedule.*
- *Fluid level in reservoir will decrease with brake wear. Reservoir volume is adequate to provide fluid to the wear limits of the pads and rotors.*

1. Check front brake lever and foot pedal. Each must have a firm feel when applied. Repeat the bleeding procedure if brakes feel spongy. See BLEED BRAKES (Page 3-60).
2. Position vehicle on a flat level surface.
  - a. Front brake: Position motorcycle and handlebar so that master cylinder reservoir is level.
  - b. Rear brake: Position motorcycle so that master cylinder reservoir is level.
3. See Figure 2-21. View reservoir sight glass. Fluid level must be at or above the minimum mark on glass. If fluid level is below minimum mark:
  - a. Check brake system for fluid leaks.
  - b. Check that brake pads and rotors are properly installed and not worn beyond service wear limits. See INSPECT BRAKES (Page 2-19).
  - c. Check fluid level in brake reservoir. If necessary, add DOT 4 BRAKE FLUID to reservoir. See Table 2-10.

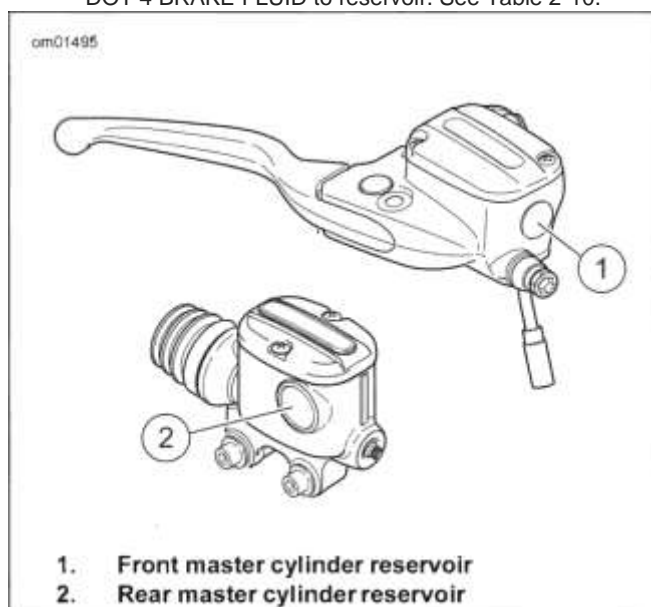


Figure 2-21. Sight Glass Minimum Marks

## DRAIN AND REPLACE FLUID <sup>2 3</sup>

| PART NUMBER | TOOL NAME                  |
|-------------|----------------------------|
| BB200A      | BASIC VACUUM BRAKE BLEEDER |
| HD-48650    | DIGITAL TECHNICIAN II      |

| FASTENER   | TORQUE VALUE  |              |
|--|---------------|--------------|
| Brake bleeder screw, front                           | 72-108 in-lbs | 8.1-12.2 N-m |
| Brake bleeder screw, rear                            | 75-102 in-lbs | 8.5-11.5 N-m |
| Brake master cylinder, front, reservoir cover screws | 12-15 in-lbs  | 1.4-1.7 N-m  |
| Brake master cylinder, rear, reservoir cover screws  | 12-15 in-lbs  | 1.4-1.7 N-m  |

### NOTE

- 3 Flush brake system and replace DOT 4 fluids every two years per maintenance schedule.

- **BASIC VACUUM BRAKE BLEEDER (PART NUMBER: BB200A) or equivalent tool is required.**
  - *This procedure is meant to replace fluid without introducing air. If any air enters lines during this procedure, revert to BLEED BRAKES (Page 3-60).*
  - **DIGITAL TECHNICIAN II (PART NUMBER: HD-48650) is required when servicing models having ABS.**
1. Remove bleeder screw cap. Install vacuum brake bleeder to bleeder screw.
  2. Position vehicle or handlebar so master cylinder reservoir is level.

**NOTE**

- *Wrap a clean shop towel around the outside of the master cylinder reservoir to protect paint from brake fluid spills.*
  - *Clean master cylinder reservoir cover before removal.*
3. Remove cover from master cylinder reservoir.

**NOTE**

*A bulge may not be seen on models having remote reservoirs.*

4. Add brake fluid as necessary. Verify proper operation of the master cylinder relief port by actuating the brake pedal or lever. A slight bulge of fluid will break the fluid surface in the reservoir if internal components are working properly. Refer to Table 2-10.

**NOTE**

*Pay careful attention to fluid level in the master cylinder reservoir. Add fluid before it empties to avoid drawing air into the brake lines.*

5. Operate vacuum bleeder while maintaining fluid level in master cylinder reservoir.
  - a. Following the sequence in Table 2-12, open bleeder screw about 3/4 turn.
  - b. Continue until specified volume has been replaced. Refer to Table 2-12.
  - c. Tighten bleeder screw to specification. Refer to Table 2-11. Install bleeder screw cap.
6. Repeat with each caliper following the sequence in Table 2-12 until all brake lines have been serviced.
7. Fill reservoir to specified level. Refer to Table 2-10.

8. Refer to Table 2-11. Clean gasket and sealing surfaces of debris. Install master cylinder reservoir covers:
  - a. **Front master cylinder reservoir:** Install the cover with the vent holes facing the rear. Install cover screws. Tighten to specification.
  - b. **Rear master cylinder reservoir:** Install cover screws. Tighten to specification.
9. **ABS models:** Use DIGITAL TECHNICIAN II (PART NUMBER: HD-48650) and perform "ABS Service" procedure.
10. Apply brakes to check proper lamp operation.

**A WARNING**

**After repairing the brake system, test brakes at low speed. If brakes are not operating properly, testing at high speeds can cause loss of control, which could result in death or serious injury. (00289a)**

11. Test ride motorcycle. Perform the bleeding procedure if brakes feel spongy.

**Table 2-10. Fluid Level**

| ITEM            | SPECIFICATION         |
|-----------------|-----------------------|
| Front reservoir | Boss or ridge         |
| Rear reservoir  | Ledge or range window |

**Table 2-11. Torque Specifications**

| COMPONENT            | TORQUE                              |
|----------------------|-------------------------------------|
| Bleeder screw, front | 72-108 <b>in-lbs</b> (8.1-12.2 N-m) |
| Bleeder screw, rear  | 75-102 <b>in-lbs</b> (8.5-11.5 N-m) |
| Front cover          | 12-15 <b>in-lbs</b> (1.4-1.7 N-m)   |
| Rear cover           | 12-15 <b>in-lbs</b> (1.4-1.7 N-m)   |

**Table 2-12. Bleeding Sequence**

| SYSTEM TYPE | CIRCUIT     | VOLUME           |
|-------------|-------------|------------------|
| Non-ABS     | Front left  | 3 fl oz (89 ml)  |
|             | Front right | 3 fl oz (89 ml)  |
|             | Rear        | 3 fl oz (89 ml)  |
| ABS         | Front left  | 6 fl oz (178 ml) |
|             | Front right | 3 fl oz (89 ml)  |
|             | Rear        | 3 fl oz (89 ml)  |

**INSPECT BRAKE LINES**

Inspect brake lines for leaks, contact or abrasion. Refer to Table 2-13.

**Table 2-13. Brake Line Inspection**

| LINE TYPE                        | INSPECTION   | REMEDY       |
|----------------------------------|--|--------------|
| Steel lines                      | No marks   | Okay/Monitor |
|                                  | Slight mark in paint or plating*                         |              |
|                                  | Copper colored-paint/plating worn off*                   |              |
|                                  | Silver colored base material-no noticeable feel of wear* |              |
|                                  | Silver colored base material-noticeable feel of wear*    | Replace      |
| Brake fluid leak or other damage |  |              |

**Table 2-13. Brake Line Inspection**

| LINE TYPE  | INSPECTION   | REMEDY       |
|--|--|--------------|
| Flexible lines   | No marks   | Okay/Monitor |
|  | Slight dent in protective cover or flattening of ribs*   |              |
|  | Worn through protective cover or to bottom of ribs       | Replace      |
|  | Brake fluid leak or other damage                         |              |
| Protective cover<br>(steel, rubber, plastic or braided)  | No marks   | Okay/Monitor |
|  | Slight dent in covering*                                 |              |
|  | Slight dent or flattening of plastic covering*           |              |
|  | Worn or cut-through covering-exposed brake line material | Replace      |
| Brake fluid leak or other damage   |  |              |
| * If there is line contact, reposition the line. If base material is visible, prevent corrosion with touch-up paint. |  |              |

## CHECK AND ADJUST

| FASTENER          | TORQUE VALUE  |              |
|-------------------|---------------|--------------|
| Clutch hub jamnut | 72-120 in-lbs | 8.1-13.6 N-m |

### Adjust

1. Stand motorcycle upright (not leaning on jiffy stand) on a level surface. Front wheel straight ahead.
2. See Figure 2-22. Access two piece clutch cable.
  - a. Remove lower clip (3).
  - b. Remove clutch cable from upper clip (1).
  - c. Remove clip above cover.
  - d. Slide cover (2) up.

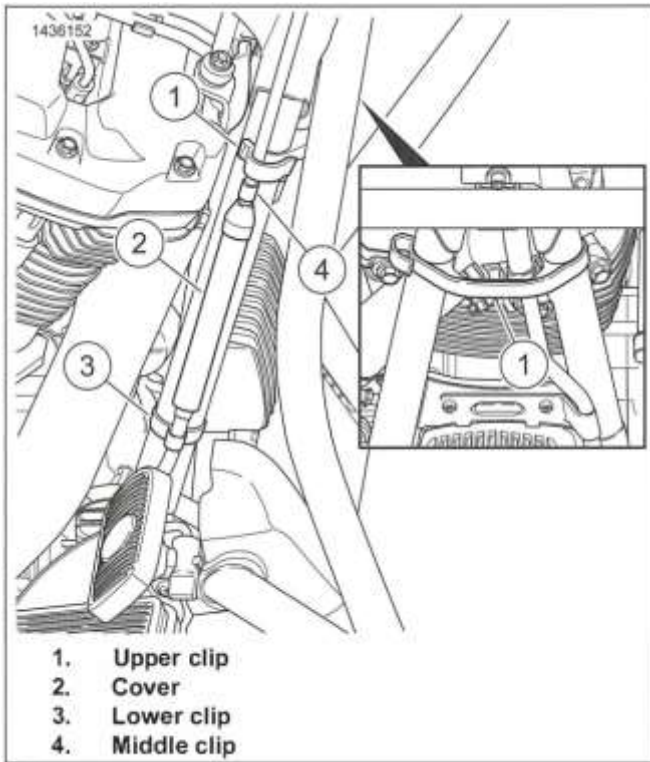


Figure 2-22. Clutch Adjuster Location

3. See Figure 2-23. Identify upper clutch cable (1) and red lock button (2).

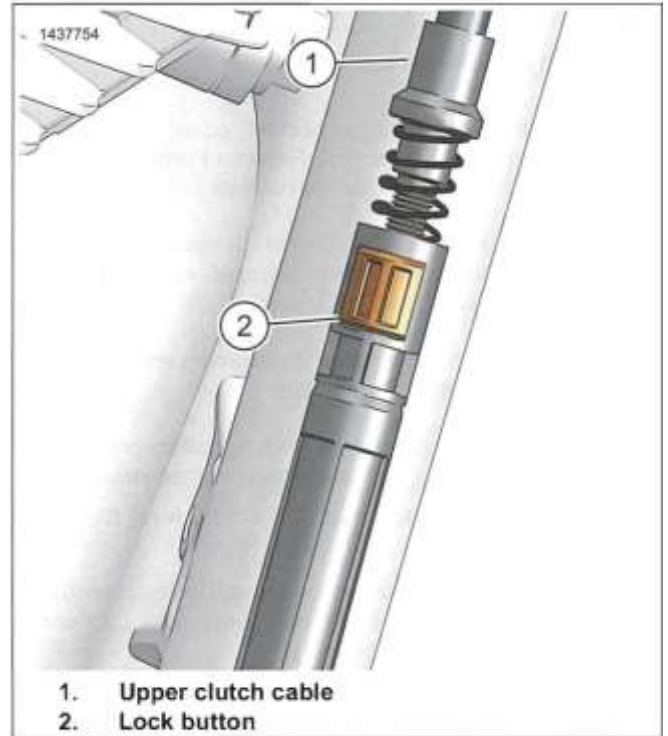
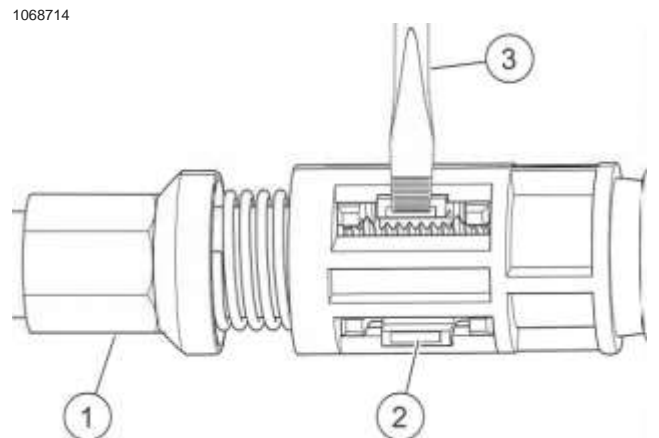


Figure 2-23. Lock Button

4. **NOTE**  
*Inspect tabs on lock button (2). Replace if damaged.*

See Figure 2-24. Unlock upper clutch cable (1).

- a. Push tabs on lock button (2) slightly inboard and then down to disengage.
5. Fully collapse cable (spring compressed) and push button in. This releases cable tension.



1. Upper clutch cable
2. Lock button
3. Screwdriver

Figure 2-24. Compressed Upper Clutch Cable

### NOTE

*Perform clutch adjustment with motorcycle at room temperature. Clearance at adjuster screw increases as*

powertrain temperature increases. If adjustment is made when hot, clearance at pushrod bearing could be insufficient when cold. Clutch slippage could occur.

6. Adjust clearance at hub.

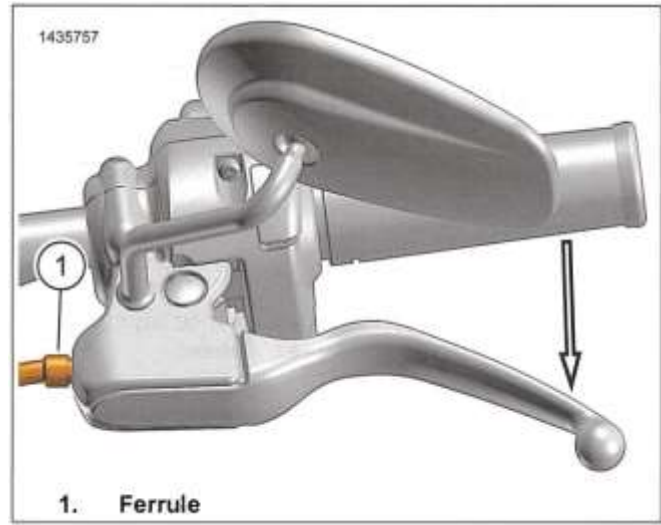
- a. Remove clutch inspection cover from primary chaincase cover. See Replace Primary Chaincase Lubricant in the service manual.
- b. See Figure 2-25. Loosen jamnut (1) on clutch adjuster screw. Turn adjuster screw (2) inward (clockwise) until lightly seated.
- c. Squeeze clutch lever to maximum limit three times to set release mechanism.
- d. Back out adjuster screw one-half to one full turn. While holding adjuster screw, tighten jamnut. Torque: 72-120 in-lbs (8.1-13.6 N-m) *Clutch hub jamnut*
- e. Secure clutch inspection cover. Tighten in sequence. See See Replace Primary Chaincase Lubricant in the service manual.



1. Jamnut  
2. Clutch adjuster screw

Figure 2-25. Clutch Adjuster Screw

7. See Figure 2-26. Ensure clutch lever is in full open position and that ferrule (1) is correctly seated in housing.



1. Ferrule

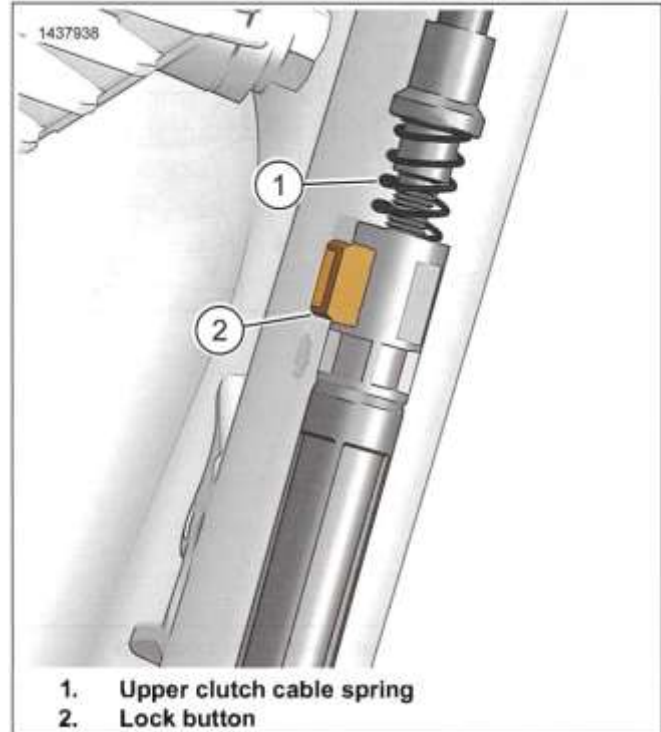
Figure 2-26. Clutch Lever Full Open

8. See Figure 2-24. Disengage lock button (2) allowing upper clutch cable spring (1) to set free-play at clutch lever.

NOTE

Inspect lock button (2). Replace if damaged.

9. Push in lock button (2).



1. Upper clutch cable spring  
2. Lock button

Figure 2-27. Secure Lock Button

10. See Figure 2-28. Check free-play (3) at clutch lever.

- a. If free-play is not to specification, check for proper clutch cable routing.
- b. Repeat steps 8 and 9.

11. Check clutch operation.

12. See Figure 2-22. Slide cover (2) down.



13. Instal clutch cable in upper clip (1).

14. Install small C clip above cover.

15. Install lower clip (3).

### Clutch Cable Only Check

1. Rotate front wheel straight ahead.

2. See Figure 2-28. Check free play.

a. Pull clutch cable ferrule (1) away from clutch lever bracket (2).

b. Check free play (3) dimension. Refer to Table 2-14.

c. Adjust clutch. See Adjustment in this section.

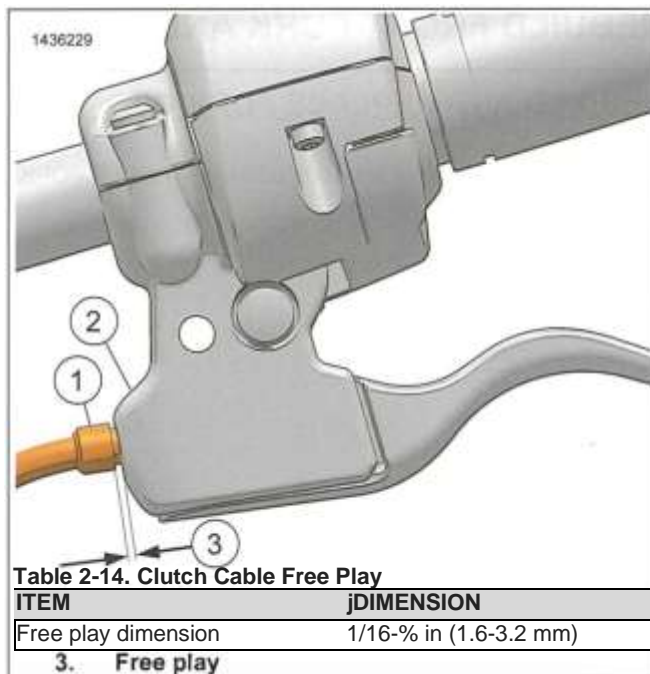


Figure 2-28. Clutch Cable Free Play

### REBUILD AND REPLACE FORK OIL

For this scheduled maintenance procedure, see FRONT FORK  
(Page 3-64).

## CHECK AND ADJUST

| FASTENER                        | TORQUE VALUE |               |
|---------------------------------|--------------|---------------|
| Upper steering stem pinch screw | 22-26 ft-lbs | 29.8-35.2 N-m |

### A WARNING

Properly adjust fork stem bearings. Improper adjustments can adversely affect stability and handling, which could result in death or serious injury. (00301c)

### NOTICE

When lifting a motorcycle using a jack, be sure jack contacts both lower frame tubes where down tubes and lower frame tubes converge. Never lift by jacking on cross-members, oil pan, mounting brackets, components or housings. Failure to comply can cause serious damage resulting in the need to perform major repair work. (00586d)

### NOTE

- A steering head that is too tight can interfere with the vehicle's ability to absorb a weave. A steering head that is too loose can interfere with the vehicle's ability to absorb a wobble.
- This procedure is for 2-wheel vehicles only. Trike does not require this check due to the use of a steering damper.

## Measure Swing-Back

### NOTE

Vehicle must be in original equipment configuration.

1. Remove all accessory weight, such as a windshield bag and contents or handlebar-mounted navigation unit. These items can influence the way the front fork swings.
2. **Models with cable clutch:** Disconnect clutch cable from hand control. Secure out of the way.
3. **Models with hydraulic clutch:** Leave fully assembled.

### NOTE

Lower frame rails **MUST** be level in both directions for a valid check.

4. Raise vehicle.
  - a. Lift entire vehicle until tires are off ground.
  - b. Place a block under rear tire.
  - c. Gently lower vehicle until tire contacts block.
5. Using a level, verify lower frame rails are level front to rear and left to right.
6. Swing front end from stop-to-stop to check for smooth movement.

### NOTE

A clunk indicates loose fork stem.

7. Verify there is no clunk.
  - a. Grasp both forks near front axle.
  - b. Shake forks front to rear checking for a clunk. If clunk is heard, see Lubricate in this section.
8. Attach lightweight cardboard to fender.
  - a. Obtain a lightweight cardboard piece of specified length.  
8-10 in (20-25 cm)
  - b. Tape cardboard to front fender centered and even with fender tip.
9. Place a stationary pointer tip near the cardboard. With front wheel straight forward, center pointer on cardboard.

### NOTE

To avoid confusion, use three different colors to make the following marks.

10. See Figure 2-29. Make initial marks.
  - a. Lightly tap front tire to the left until it just begins to swing back toward center.
  - b. Using the first color, mark the point (1) where it began to swing back.
  - c. Repeat by lightly tapping front tire to the right.
  - d. Using the first color, mark the point (1) where it began to swing back.
11. Repeat two more times in each direction to validate marks.
12. Add measured points (2).
  - a. Measure outboard specified distance from each mark (1).  
1 in (25.4 mm)
  - b. Using second color, mark these points (2).
13. Mark the swing-back stops.

### NOTE

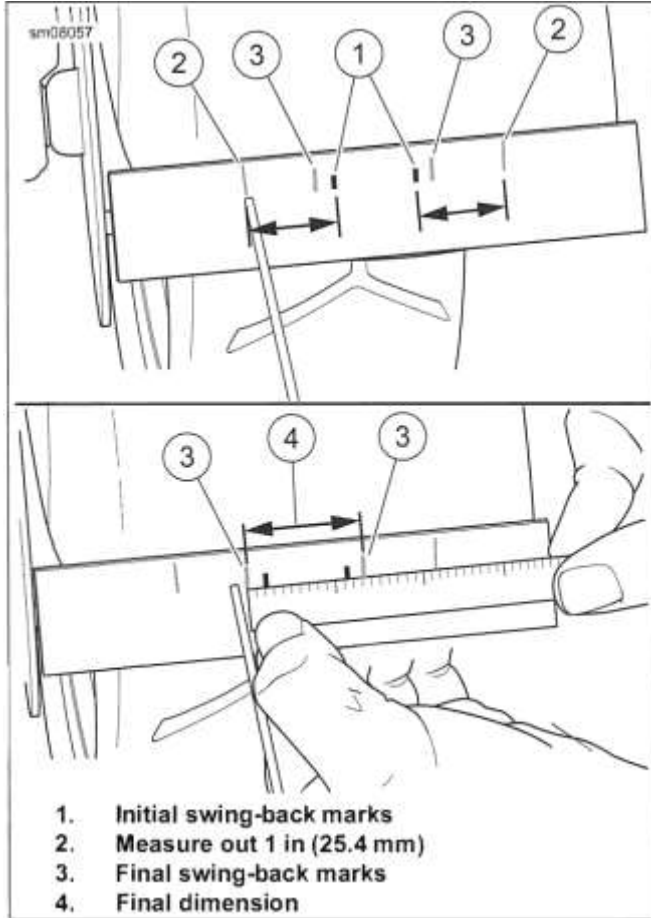
If upon releasing the front end from marks 2(L) and 2(R), marks 3(L) and 3(R) pass each other, steering is too loose. Proceed to Adjusting Swing-Back later in this section.

- a. Turn the front end until pointer is at left mark (2) and release.
- b. Using third color, mark where swing-back stops (3).
- c. Turn the front end until pointer is at right mark (2) and release.
- d. Using third color, mark where swing-back stops (3).

14. Repeat two more times in each direction to validate marks.
15. Measure distance (4) between final swing-back marks (3). Readings must be within values specified. Refer to Table 2-15.

**NOTE**

A measurement greater than specification indicates steering stem is too tight. A measurement less than specification indicates steering stem is too loose. To adjust, see Adjusting Swing-Back below.



**Figure 2-29. Marking and Measuring Swing Points**

**Table 2-15. Steering Swing-Back**

| MODEL   | SPECIFICATION         |
|---|-----------------------|
| FLHR, FLHP  | 3.4-4.8 in (9-12 cm)  |
| FLHRXS  | 5.5-6.5 in (14-17 cm) |
| FLHT (without radio)  | .8-1.2 in (2-3 cm)    |
| FLHT (with radio and speakers),<br>FLHTK, FLHTKSE, FL-HTP,<br>FLHX, FLHXS, FLHXSE | 1.7-2.6 in (4-7 cm)   |
| FLTRK   | 2.7-3.3 in (7-8 cm)   |
| FLTRX, FLTRXS   | 5.2-5.7 in (13-14 cm) |
| FLTRXSE   | 4.9-5.5 in (12-14 cm) |
| Trike   | N/A                   |

**Adjust Swing-Back**

**NOTE**

- A steering head that is too tight can interfere with the vehicle's ability to absorb a weave. A steering head that is too loose can interfere with the vehicle's ability to absorb a wobble.
- This procedure is for 2-wheel vehicles only Trike does not require this check due to the use of a steering damper.

1. Disassemble motorcycle:
  - a. Road King models: Remove headlamp. See HEADLAMP (Page 8-41).
  - b. Fork-mounted fairing models: Remove outer fairing. See FAIRING: FORK MOUNTED (Page 3-89).
  - c. Frame-mounted fairing models: Remove instrument nacelle. See FAIRING: FRAME MOUNTED (Page 3-100).

2. See Figure 2-30. Loosen upper steering stem pinch screw (1).

**NOTE**

Protect front fender from damage.

3. Adjust steering stem:
  - a. Engage a 1/4 inch drive extension (3) six inches long into the bottom of upper steering stem (2).
  - b. Based on swing-back dimension, tighten (4) (to increase dimension) or loosen (5) (to decrease dimension) the upper steering stem a few degrees.
  - c. Tighten steering stem pinch screw to 22-26 ft-lbs (29.8-35.2 N-m).

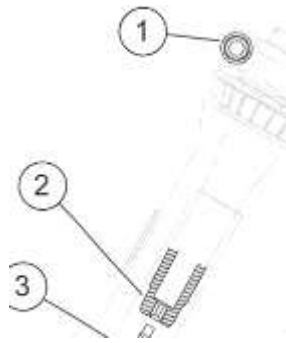
**NOTE**

It is important that all original mass be in place to accurately measure swing-back.

4. Temporarily install all removed original equipment components. Do not tighten fasteners.
5. Check swing-back. Repeat until swing-back is within specification.
6. Assemble motorcycle:

- a. Road King models: Install headlamp. See HEADLAMP (Page 8-41).
- b. Fork-mounted fairing models: Install outer fairing. See FAIRING: FORK MOUNTED (Page 3-89).
- c. Frame-mounted fairing models: Install instrument nacelle. See FAIRING: FRAME MOUNTED (Page 3-100).

7. Install any accessories removed earlier.



1. Upper steering stem pinch screw
2. Upper steering stem
3. 1/4 in drive extension
4. Tighten
5. Loosen

Figure 2-30. Adjust Steering Stem Bearings

**LUBRICATE**

| FASTENER  | TORQUE VALUE |          |
|---|--------------|----------|
|   |              |          |
| Upper steering stem, final torque: Fork mounted fairing models  | 63 in-lbs    | 7.1 N-m  |
| Upper steering stem, final torque: Frame mounted fairing models | 192 in-lbs   | 21.7 N-m |
| Upper steering stem, final torque: Road King models             | 108 in-lbs   | 12.2 N-m |
| Upper steering stem, final torque: Trike models                 | 108 in-lbs   | 12.2 N-m |
| Upper steering stem, first torque                               | 35 ft-lbs    | 47.5 N-m |

1. Disassemble motorcycle:

- a. Road King models: Remove headlamp nacelle. See HEADLAMP NACELLE (Page 3-87).
- b. Fork-mounted fairing models: Remove inner fairing. See FAIRING: FORK MOUNTED (Page 3-89).
- c. Frame-mounted fairing models: Remove the instrument nacelle. See FAIRING: FRAME MOUNTED (Page 3-100).

2. Raise front end until tire is just touching surface.
3. Remove upper fork bracket and handlebar as an assembly. Support out of the way. See STEERING HEAD (Page 3-71).

*NOTE*

The upper fork bracket acts as a fork stop. Place wooden block between lower fork bracket and frame to avoid damage.

4. Remove upper steering stem. See STEERING HEAD (Page 3-71).
5. Raise motorcycle until lower stem bearing has exited far enough to clean grease from bearing cup and cone.

*NOTE*

Remove grease with a clean cloth or finger. Do not use solvent.

6. Wipe grease from upper and lower bearing cups and cones. Inspect parts for wear or damage.
7. Pack bearings with SPECIAL PURPOSE GREASE.
8. Lower motorcycle until lower bearing just seats. Do not place entire weight of vehicle on bearing.
9. Apply SPECIAL PURPOSE GREASE to the threads of the upper and lower steering stems.
10. Install upper steering stem. Tighten to 35 ft-lbs (47.5 N-m).
11. Lower vehicle until forks begin to compress.
12. Loosen upper steering stem 90-100 degrees. Tighten to specification. Refer to Table 2-16.
13. Install upper fork bracket and handlebar. Assemble motorcycle. See STEERING HEAD (Page 3-71).
14. Check swing-back. See ADJUST AND LUBRICATE STEERING HEAD BEARINGS (Page 2-31).

Table 2-16. Steering Stem Torque

| MODEL  | TORQUE                |
|--|-----------------------|
| FLHT, FLHTK, FLHTKSE, FLHX, FLHXS, FLHXSE, FLHTP | 63 in-lbs (7.1 N-m)   |
| FLTRK, FLTRX, FLTRXS, FLTRXSE                    | 192 in-lbs (21.7 N-m) |
| FLHR, FLHRXS, FLHP                               | 108 in-lbs (12.2 N-m) |
| FLHTCUTG, FLHTCUT-GSE, FLRT                      | 108 in-lbs (12.2 N-m) |

## NOTICE

**GENERAL**

Use only Genuine Harley-Davidson Extended Life Antifreeze and Coolant. Use of other coolants/mixtures may lead to motorcycle damage. (00179c)

GENUINE HARLEY-DAVIDSON EXTENDED LIFE ANTIFREEZE AND COOLANT is pre-diluted and ready to use full strength. It provides temperature protection to -34° F (-36.7° C). DO NOT add water.

## NOTICE

De-ionized water must be used with the antifreeze in the cooling system. Hard water can cause scale accumulation in water passages which reduces cooling system efficiency, leading to overheating and motorcycle damage. (00195b)

If GENUINE HARLEY-DAVIDSON EXTENDED LIFE ANTIFREEZE AND COOLANT is unavailable, a mixture of de-ionized water and ethylene glycol-based antifreeze may be used. At the first opportunity, change back to GENUINE HARLEY-DAVIDSON EXTENDED LIFE ANTIFREEZE AND COOLANT.

**CLEAN RADIATOR**

1. See Figure 2-31. Remove grille panel from lower fairing.
  - a. Carefully pry on curved edge of panel to release latches.
  - b. Remove from fascia.
2. Clean debris from radiator fins.

3. Install grille.

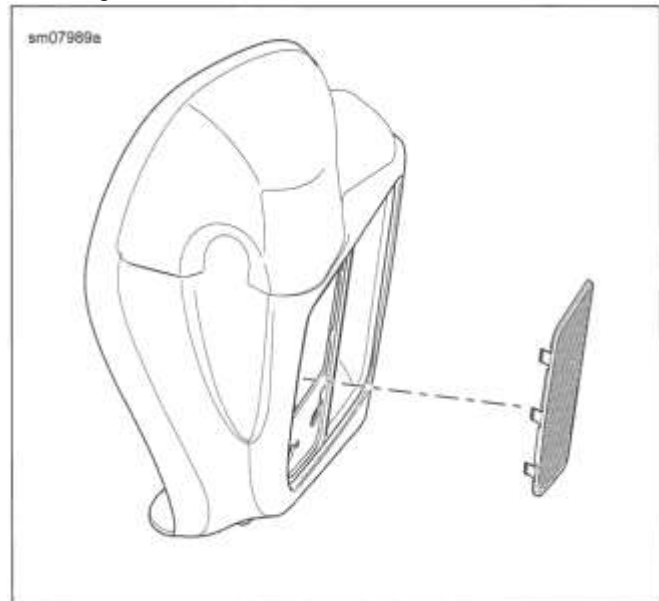


Figure 2-31. Lower Fairing Grille Panel

**INSPECT****Check Freeze Point**

For this scheduled maintenance procedure, see DIAGNOSE AND TEST (Page 7-5).

**Check for leaks**

For this scheduled maintenance procedure, see DIAGNOSE AND TEST (Page 7-5).

**DRAIN AND FILL COOLING SYSTEM**

For this scheduled maintenance procedure, see COOLANT (Page 7-8).

## INSPECT

For this scheduled maintenance procedure, see FUEL LINE  
(Page 6-8).

## INSPECT AND LUBRICATE

For this scheduled maintenance procedure, see JIFFY STAND (Page 3-146).



## INSPECT

## General

**A WARNING**

Never bend belt forward into a loop smaller than the drive sprocket diameter. Never bend belt into a reverse loop. Over bending can damage belt resulting in premature failure, which could cause loss of control and death or serious injury. (00339a)

In the case of stone damage to belt, inspect the sprockets for damage and replace as required. If replacing belt, always replace both transmission and rear sprockets.

## Cleaning

Keep dirt, grease, oil, and debris off the drive belt and sprockets. Clean the belt with a rag slightly dampened with a light cleaning agent.

## Sprockets

1. See Figure 2-32. Inspect each tooth (1) of rear sprocket for:
  - a. Major tooth damage
  - b. Large chrome chips with sharp edges
  - c. Gouges caused by hard objects
  - d. Excessive loss of chrome plating (see next step)
2. Check for worn chrome plating. Drag a sharp object across the bottom of a groove (2) using medium pressure.
  - a. If sharp object slides across groove without digging in or leaving a visible mark, chrome plating is still good.
  - b. If sharp object digs in and leaves a visible mark, it is cutting the bare aluminum. The chrome plating is worn.
3. Replace rear sprocket if major tooth damage or loss of chrome exists.

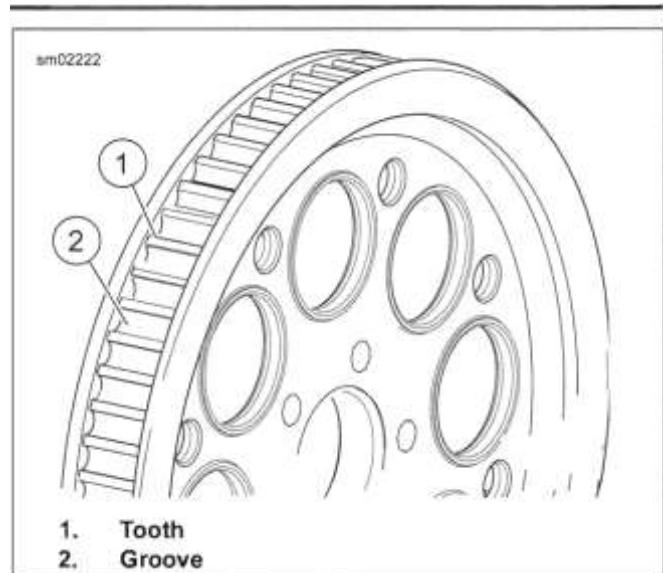


Figure 2-32. Rear Sprocket

## Drive Belt

See Figure 2-33 and Refer to Table 2-17. Inspect drive belt for:

- Cuts or unusual wear patterns
- Outside bevel wear (8). Some beveling is common, but it indicates that sprockets are misaligned
- Outside ribbed surface for signs of stone damage (7). If cracks or other damage exists near edge of belt, replace belt immediately. Damage to center of belt eventually requires belt replacement. However, when cracks extend to edge of belt, failure is imminent
- Inside (toothed portion) of belt for exposed tensile cords (normally covered by nylon layer and polyethylene layer). Replace belt and transmission sprocket
- Signs of puncture or cracking at the base of the belt teeth. Replace belt if either condition exists
- Replace belt if conditions 2, 3, 6 or 7 (on edge of belt) exist

**NOTE**

*Condition 1 may develop into 2 or 3 over time. Condition 1 is not grounds for replacing the belt, but it should be watched closely before condition 2 develops which will require belt replacement.*

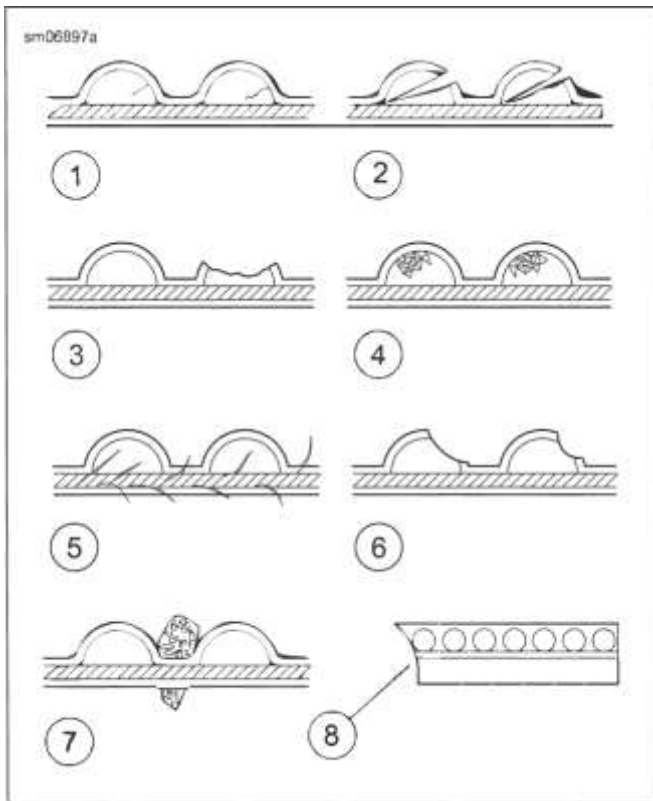


Figure 2-33. Drive Belt Wear Patterns

Table 2-17.

| NO. | CONDITION                        | REQUIRED ACTION                        |
|-----|----------------------------------|--|
| 1   | Internal tooth cracks (hairline) | OK to run, but monitor condition.      |
| 2   | External tooth cracks            | Replace belt.                          |
| 3   | Missing teeth                    | Replace belt.                          |
| 4   | Chipping (not serious)           | OK to run, but monitor condition.      |
| 5   | Fuzzy edge cord                  | OK to run, but monitor condition.      |
| 6   | Hook wear                        | Replace belt and sprocket.             |
| 7   | Stone damage                     | Replace belt if damage is on the edge. |
| 8   | Bevel wear (outboard edge only)  | OK to run, but monitor condition.      |

### MEASURE DRIVE BELT DEFLECTION

**NOTE**

| PART NUMBER | TOOL NAME          |
|-------------|--------------------|
| HD-35381-A  | BELT TENSION GAUGE |

Always use BELT TENSION GAUGE (PART NUMBER: HD-35381-A) to measure belt deflection. Failure to use tension gauge may cause under-tensioned belts. Loose belts can fail due to "ratcheting" (flumping a tooth) which causes tensile cord crimping and breakage.

Check deflection:

- With transmission in neutral.
- With motorcycle at ambient temperature.
- With motorcycle upright and rear wheel suspended off of the ground.

- With the vehicle unladen: no rider, no luggage and empty saddlebags.

**A WARNING**

To prevent accidental vehicle start-up, which could cause death or serious injury, remove main fuse before proceeding. (00251b)

1. Disarm security system. Remove main fuse. See POWER DISCONNECT (Page 8-8).
2. Shift transmission to neutral.
3. Raise vehicle until rear wheel is suspended.

**NOTE**

When adjusting a **new belt**, rotate rear wheel a few revolutions prior to setting the tension.

4. See Figure 2-34. Measure belt deflection using BELT TENSION GAUGE (PART NUMBER: HD-35381-A):
  - a. Slide O-ring (4) to zero mark (3).
  - b. **Models equipped with belt deflection window:** Fit belt cradle (2) against bottom of drive belt in line with belt deflection window.
  - c. **All other models:** Fit belt cradle (2) against bottom of drive belt halfway between drive pulleys.
  - d. Press upward on knob (6) until O-ring slides down to 10 lb (4.54 kg) mark (5) and hold steady.

**NOTE**

Measure belt tension four times, rotating the rear wheel 90 degrees between each measurement. Average the four measurements for accurate belt deflection.

5. Measure belt deflection:
  - a. **Models equipped with belt deflection window:** See Figure 2-35. Measure belt deflection as viewed through belt deflection viewing window while holding gauge steady. Each deflection graduation is approximately 1/16 in (1.6 mm).
  - b. **All other models:** See Figure 2-36. Measure amount of deflection (4) while holding gauge steady.

**NOTE**

Service belt tension specification is for belts with more than 1000 mi (1,600 km). Set belt to new belt tension specification if the belt has less than 1000 mi (1,600 km).

6. Compare with specifications. Refer to Table 2-18. If not within specifications, see a Harley-Davidson dealer.
7. Install main fuse.

Table 2-18. Belt Deflection

| MODEL  | NEW                       | SERVICE INTERVAL           |
|--|---------------------------|----------------------------|
| FLHX, FLHXS, FLHXSE, FLTRX, FLTRXS, FLHRXS (low profile shock absorbers)         | 0.13-0.37 in (3.3-9.5 mm) | 0.25-0.44 in (6.4-11.1 mm) |
| All except FLHX, FLHXS, FLHXSE, FLTRX, FLTRXS, FLHRXS (standard shock absorbers) | 0.13-0.37 in (3.3-9.5 mm) | 0.37-0.56 in (9.5--14.3mm) |

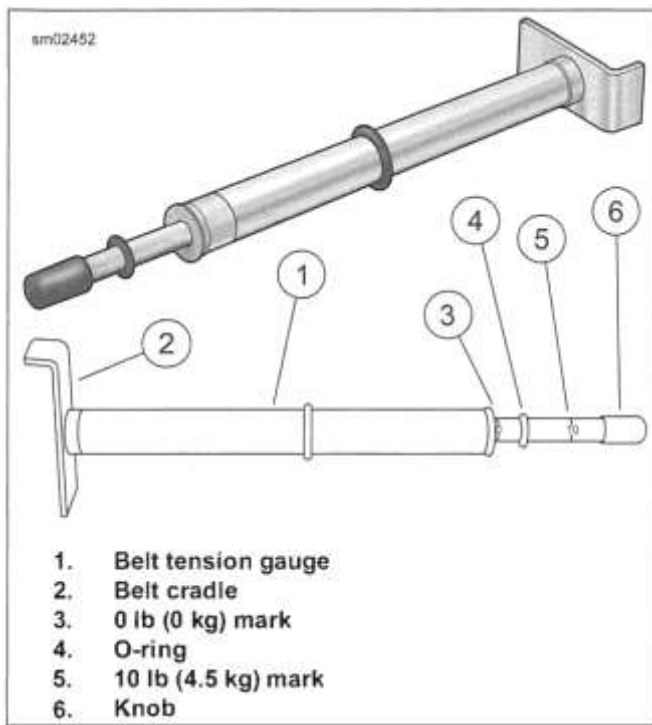


Figure 2-34. Belt Tension Gauge

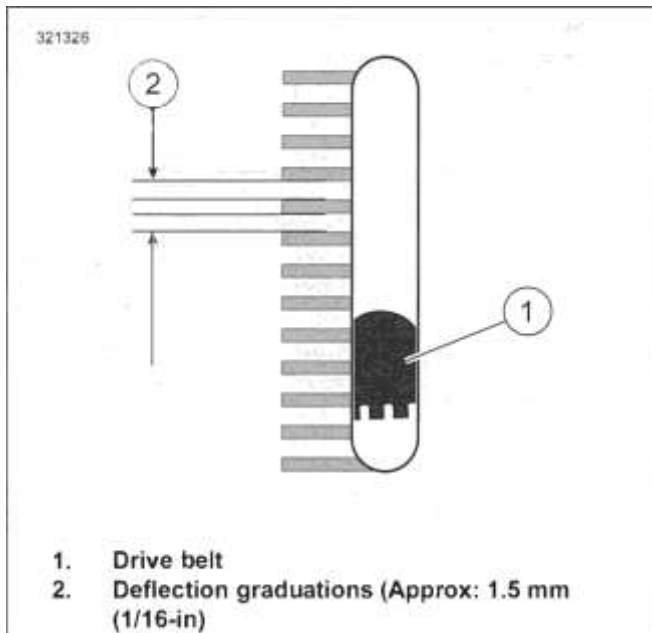


Figure 2-35. Belt Deflection Window

## ADJUST BELT

### Prepare

1. Disarm security system. Remove main fuse. See POWER DISCONNECT (Page 8-8).
2. Remove both saddlebags.
3. If AXLE NUT TORQUE ADAPTER (PART NUMBER: HD-47925) is not available, remove both mufflers. See MUFFLERS (Page 6-33).

### Adjust

1. Remove and discard E-clip from groove at end of axle.
2. See Figure 2-37. Install adapter perpendicular to breaker bar. For best clearance with muffler, install torque adapter on the outboard side.

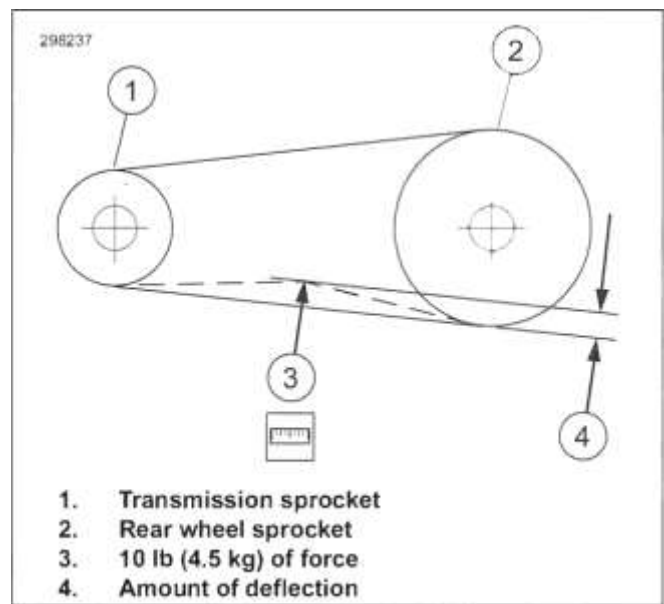


Figure 2-36. Checking Belt Deflection

| PART NUMBER | TOOL NAME               |
|-------------|-------------------------|
| HD-47925    | AXLE NUT TORQUE ADAPTER |

| FASTENER                            | TORQUE VALUE   |               |
|-------------------------------------|----------------|---------------|
| Muffler to saddlebag support screws | 14-18 ft-lbs   | 19-24.4 N-m   |
| Rear axle cone nut, 1st torque      | 15-20 ft-lbs   | 20-27 N-m     |
| Rear axle cone nut, final torque    | 135-145 ft-lbs | 183-196.6 N-m |

Special Tool: AXLE NUT TORQUE ADAPTER (HD-47925)

#### NOTE

*Detaching the mufflers from the saddlebag frames will improve access.*

3. Loosen cone nut.

#### NOTE

*The torque wrench must be perpendicular to the torque adapter to obtain proper torque.*

4. Install adapter on torque wrench, perpendicular to torque wrench.

Special Tool: AXLE NUT TORQUE ADAPTER (HD-47925)

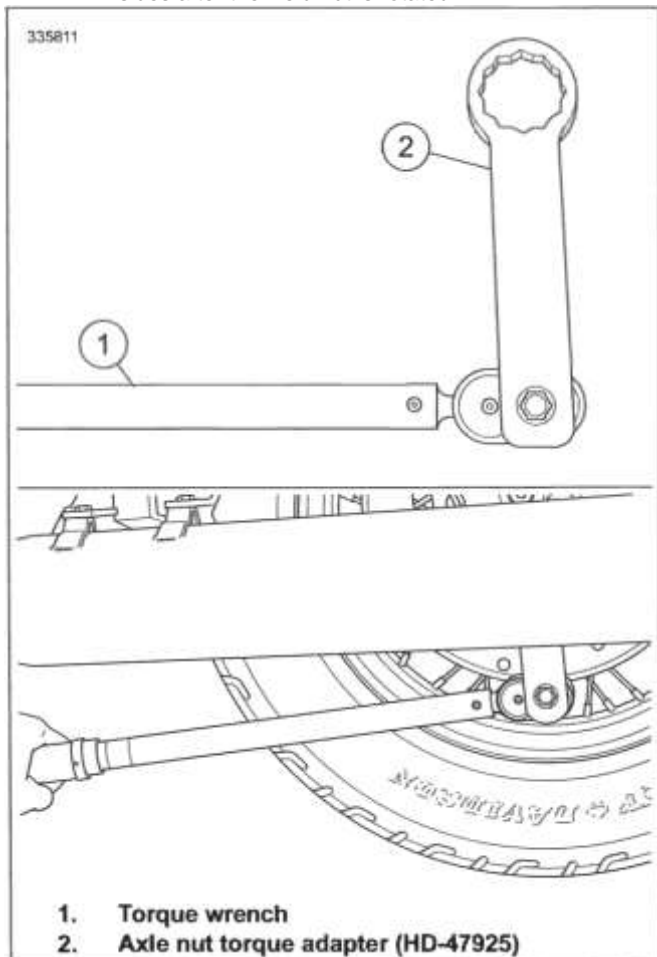
5. See Figure 2-38. Push wheel forward. Verify that cam (5) contacts boss (4) on both sides of rear fork.
6. Snug cone nut (6).  
Torque: 15-20 ft-lbs (20-27 N-m) *Rear axle cone nut, 1st torque*

7. **NOTE**

- *It is beneficial to use a second AXLE NUT TORQUE ADAPTER (PART NUMBER: HD-47925) to rotate and hold the weld nut. The position of the breaker bar or ratchet in relation to the tool is not important.*
- *Check belt deflection as adjustment is made. See Measure Drive Belt Deflection (Page 2-38).*

See Figure 2-38. Adjust belt tension.

- a. Rotate weld nut (3) on left side to adjust belt tension. Turn clockwise to tighten or counterclockwise to loosen.
- b. If loosening the belt tension, push the wheel forward.
- c. Verify both cams (5) touch the bosses (4) on both sides after the weld nut is rotated.



**Figure 2-37. Install Tool Perpendicular to Torque Wrench**

2. Install saddlebags.
3. Install main fuse. See POWER DISCONNECT (Page 8-8).

## Assemble

### NOTE

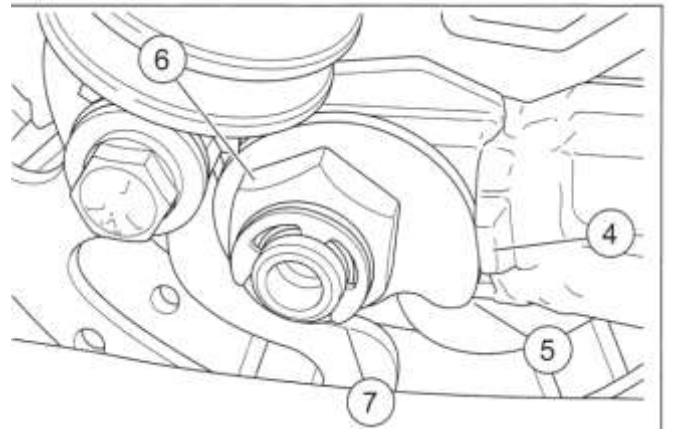
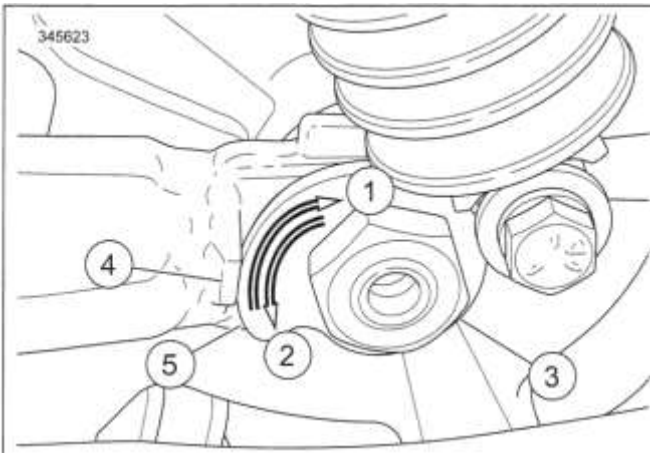
*Do not allow the weld nut to rotate once belt tension is correct.*

1. Hold weld nut and tighten cone nut.  
Torque: 135-145 ft-lbs (183-196.6 N-m) *Rear axle cone nut, final torque*
2. Again, verify the cams touch the bosses on both sides of the rear fork and that belt deflection is still within specification.
3. With the flat side out, install **new** E-clip in groove on right side of axle.

## Complete

1. If removed, install fasteners that attach mufflers to saddlebag frames and tighten.

Torque: 14-18 ft-lbs (19-24.4 N-m) *Muffler to saddlebag support screws*



- 1. Increase belt tension
- 2. Reduce belt tension
- 3. Weld nut
- 4. Boss

- 5. Adjuster cam
- 6. Cone nut
- 7. E-clip

Figure 2-38. Rear Wheel Adjuster Cams

## INSPECT

1. Support the vehicle in an upright position in neutral. Do not lift the wheels off the ground.
2. Remove left saddlebag.
3. See Figure 2-39. Hang a weighted string (1) on the left axle spacer as close as possible to, but not touching, the rear sprocket.
4. Place a piece of masking tape on the face of the sprocket where the marks will be drawn.

*NOTE*

Do not allow the rear wheel to rotate when rotating the sprocket. A false measurement will occur.

5. Rotate the rear sprocket by hand in one direction until it stops.
6. While holding the sprocket in place, mark the masking tape in line with the string.
7. Rotate the rear sprocket in the opposite direction until it stops.
8. While holding the sprocket in place, make a second mark in line with the string.
9. Measure the distance (2) along the edge of the sprocket between the marks. If the measurement exceeds 0.400 in (10.2 mm) replace the rubber isolator.

*NOTE*

Visually inspect components when disassembled. See REAR WHEEL COMPENSATOR (Page 3-24) to repair the rear wheel compensator.

- Excessive play in the compensator components is caused by deteriorated rubber segments.
- Wear on the raised "nubs" or small amounts of rubber debris are normal. This type of wear does not indicate a worn out isolator.

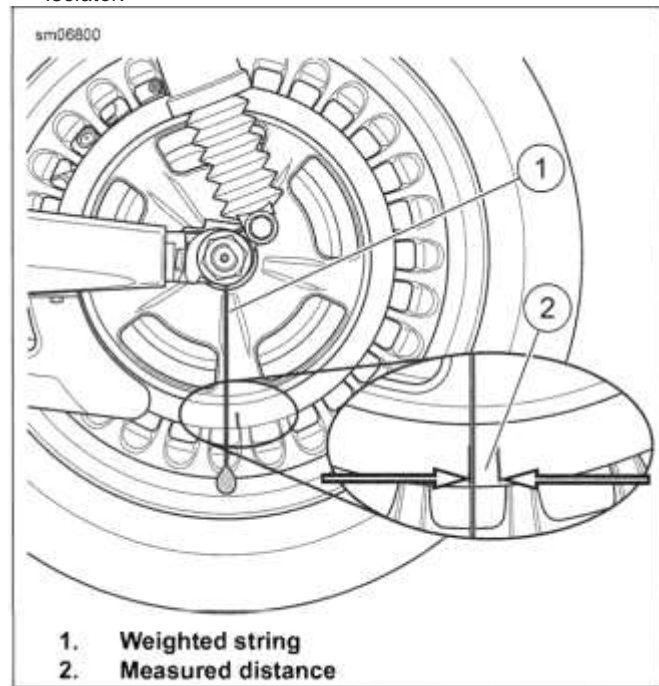


Figure 2-39. Check Compensator Wear

## ADJUST SHOCK ABSORBER

Adjust the shock absorber preload for the total weight the motorcycle is to carry.

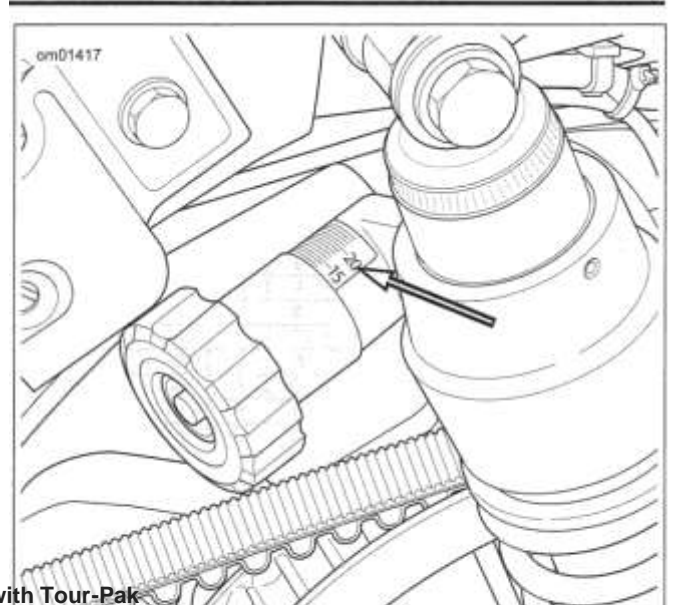
- Increase the preload to accommodate more weight.
- Reduce the preload if carrying less weight.

1. Remove the left saddlebag.

**NOTE**

A preload table wallet card is provided at the back of the owner's manual for convenience.

2. See Figure 2-40. Rotate the knob to the desired setting for the expected load. The knob will click after each half turn. Refer to Table 2-19, Table 2-20 or Table 2-21.
3. Turn the knob half turns to fine tune the ride if desired.
4. Install the left saddlebag.



**Table 2-19. Suspension Preload Table: Standard Length Shocks, with Tour-Pak**

|              |     | ADDITIONAL WEIGHT OF PASSENGER, CARGO AND ACCESSORIES |   |    |    |    |    |    |    |    |    |    |    |    |    |    |    |    |    |     |     |
|--------------|-----|---|---|----|----|----|----|----|----|----|----|----|----|----|----|----|----|----|----|-----|-----|
|              |     | LB  | 0 | 10 | 20 | 30 | 40 | 50 | 60 | 70 | 80 | 90 | 10 | 11 | 12 | 13 | 14 | 15 | 16 | 170 | 180 |
|              |     | KG  | 0 | 5  | 9  | 14 | 18 | 23 | 27 | 32 | 36 | 41 | 45 | 50 | 54 | 59 | 64 | 68 | 73 | 77  | 82  |
| RIDER WEIGHT |     | Full Turns of Knob                                    |   |    |    |    |    |    |    |    |    |    |    |    |    |    |    |    |    |     |     |
| LB           | KG  |   |   |    |    |    |    |    |    |    |    |    |    |    |    |    |    |    |    |     |     |
| 150          | 68  | 0   | 0 | 0  | 1  | 2  | 3  | 4  | 5  | 6  | 6  | 7  | 8  | 9  | 10 | 11 | 12 | 13 | 14 | 15  | 15  |
| 160          | 73  | 0   | 0 | 0  | 1  | 2  | 3  | 4  | 5  | 6  | 7  | 8  | 9  | 10 | 11 | 12 | 13 | 14 | 15 | 15  | 15  |
| 170          | 77  | 0   | 0 | 1  | 2  | 3  | 4  | 5  | 6  | 7  | 8  | 9  | 10 | 10 | 11 | 12 | 13 | 14 | 15 | 16  | 16  |
| 180          | 82  | 0   | 1 | 2  | 3  | 4  | 4  | 5  | 6  | 7  | 8  | 9  | 10 | 11 | 12 | 13 | 14 | 15 | 16 | 17  | 17  |
| 190          | 86  | 0   | 1 | 2  | 3  | 4  | 5  | 6  | 7  | 8  | 9  | 10 | 11 | 12 | 13 | 14 | 14 | 15 | 16 | 17  | 17  |
| 200          | 91  | 1   | 2 | 3  | 4  | 5  | 6  | 7  | 8  | 9  | 9  | 10 | 11 | 12 | 13 | 14 | 15 | 16 | 17 | 18  | 18  |
| 210          | 95  | 2   | 3 | 3  | 4  | 5  | 6  | 7  | 8  | 9  | 10 | 11 | 12 | 13 | 14 | 15 | 16 | 17 | 18 | 18  | 18  |
| 220          | 100 | 2   | 3 | 4  | 5  | 6  | 7  | 8  | 9  | 10 | 11 | 12 | 13 | 13 | 14 | 15 | 16 | 17 | 18 | 19  | 19  |
| 230          | 104 | 3   | 4 | 5  | 6  | 7  | 7  | 8  | 9  | 10 | 11 | 12 | 13 | 14 | 15 | 16 | 17 | 18 | 19 | 20  | 20  |
| 240          | 109 | 3   | 4 | 5  | 6  | 7  | 8  | 9  | 10 | 11 | 12 | 13 | 14 | 15 | 16 | 17 | 17 | 18 | 19 | 20  | 20  |
| 250          | 113 | 4   | 5 | 6  | 7  | 8  | 9  | 10 | 11 | 12 | 12 | 13 | 14 | 15 | 16 | 17 | 18 | 19 | 20 | 21  | 21  |
| 260          | 118 | 5   | 5 | 6  | 7  | 8  | 9  | 10 | 11 | 12 | 13 | 14 | 15 | 16 | 17 | 18 | 19 | 20 | 20 | 21  | 21  |
| 270          | 123 | 5   | 6 | 7  | 8  | 9  | 10 | 11 | 12 | 13 | 14 | 15 | 16 | 16 | 17 | 18 | 19 | 20 | 21 | 22  | 22  |

**Table 2-20. Suspension Preload Table: Standard Length Shocks, without Tour-Pak**

|              |     | ADDITIONAL WEIGHT OF PASSENGER, CARGO AND ACCESSORIES |    |    |    |    |    |    |    |    |    |    |    |    |     |     |     |     |     |     |     |
|--------------|-----|---|----|----|----|----|----|----|----|----|----|----|----|----|-----|-----|-----|-----|-----|-----|-----|
|              |     | LB  | 0  | 10 | 20 | 30 | 40 | 50 | 60 | 70 | 80 | 90 | 10 | 11 | 120 | 130 | 140 | 150 | 160 | 170 | 180 |
|              |     | KG  | 0  | 5  | 9  | 14 | 18 | 23 | 27 | 32 | 36 | 41 | 45 | 50 | 54  | 59  | 64  | 68  | 73  | 77  | 82  |
| RIDER WEIGHT |     | Full Turns of Knob                                    |    |    |    |    |    |    |    |    |    |    |    |    |     |     |     |     |     |     |     |
| LB           | KG  |   |    |    |    |    |    |    |    |    |    |    |    |    |     |     |     |     |     |     |     |
| 150          | 68  | 0   | 0  | 0  | 2  | 3  | 5  | 7  | 8  | 10 | 12 | 13 | 15 | 17 | 18  | 20  | 22  | 23  |     |     |     |
| 160          | 73  | 0   | 0  | 1  | 3  | 4  | 6  | 8  | 9  | 11 | 13 | 14 | 16 | 18 | 19  | 21  | 23  |     |     | -   |     |
| 170          | 77  | 0   | 0  | 2  | 4  | 6  | 7  | 9  | 10 | 12 | 14 | 15 | 17 | 19 | 20  | 22  | 23  |     |     | -   |     |
| 180          | 82  | 0   | 1  | 3  | 5  | 7  | 8  | 10 | 11 | 13 | 15 | 16 | 18 | 20 | 21  | 23  |     |     |     | -   |     |
| 190          | 86  | 1   | 3  | 4  | 6  | 8  | 9  | 11 | 13 | 14 | 16 | 17 | 19 | 21 | 22  | 23  |     |     |     | -   |     |
| 200          | 91  | 2   | 4  | 5  | 7  | 9  | 10 | 12 | 14 | 15 | 17 | 18 | 20 | 22 | 23  |     |     |     |     | -   |     |
| 210          | 95  | 3   | 5  | 6  | 8  | 10 | 11 | 13 | 15 | 16 | 18 | 19 | 21 | 23 |     |     |     |     |     | -   |     |
| 220          | 100 | 4   | 6  | 7  | 9  | 11 | 12 | 14 | 16 | 17 | 19 | 21 | 22 | 23 |     |     |     |     |     | -   |     |
| 230          | 104 | 5   | 7  | 8  | 10 | 12 | 14 | 15 | 17 | 18 | 20 | 22 | 23 |    |     |     |     |     |     | -   |     |
| 240          | 109 | 6   | 8  | 9  | 11 | 13 | 15 | 16 | 18 | 19 | 21 | 23 |    |    |     |     |     |     |     | -   |     |
| 250          | 113 | 7   | 9  | 10 | 12 | 14 | 16 | 17 | 19 | 20 | 22 | 23 |    |    |     |     |     |     |     | -   |     |
| 260          | 118 | 8   | 10 | 11 | 13 | 15 | 17 | 18 | 20 | 22 | 23 |    |    |    |     |     |     |     |     | -   |     |
| 270          | 122 | 9   | 11 | 13 | 14 | 16 | 18 | 19 | 21 | 23 |    |    |    |    |     |     |     |     |     | -   |     |

**Table 2-21. Suspension Preload Table: Low Length Shocks, with or without Tour-Pak**

|              |     | ADDITIONAL WEIGHT OF PASSENGER, CARGO AND ACCESSORIES |   |    |    |    |    |    |    |    |    |    |     |     |     |     |     |     |     |     |     |
|--------------|-----|---|---|----|----|----|----|----|----|----|----|----|-----|-----|-----|-----|-----|-----|-----|-----|-----|
|              |     | LB  | 0 | 10 | 20 | 30 | 40 | 50 | 60 | 70 | 80 | 90 | 100 | 110 | 120 | 130 | 140 | 150 | 160 | 170 | 180 |
|              |     | KG  | 0 | 5  | 9  | 14 | 18 | 23 | 27 | 32 | 36 | 41 | 45  | 50  | 54  | 59  | 64  | 68  | 73  | 77  | 82  |
| RIDER WEIGHT |     |   |   |    |    |    |    |    |    |    |    |    |     |     |     |     |     |     |     |     |     |
| LB           | KG  | Full Turns of Knob                                    |   |    |    |    |    |    |    |    |    |    |     |     |     |     |     |     |     |     |     |
| 150          | 68  | 0   | 0 | 0  | 1  | 2  | 3  | 4  | 5  | 6  | 7  | 8  | 9   | 10  | 11  | 13  | 14  | 15  | 16  | 17  | 18  |
| 160          | 73  | 0   | 0 | 0  | 2  | 3  | 4  | 5  | 6  | 7  | 9  | 10 | 11  | 12  | 13  | 14  | 16  | 17  | 18  | 19  |     |
| 170          | 77  | 0   | 0 | 1  | 2  | 3  | 5  | 6  | 7  | 8  | 9  | 10 | 12  | 13  | 14  | 15  | 16  | 18  | 19  | 20  |     |
| 180          | 82  | 0   | 1 | 2  | 3  | 4  | 5  | 7  | 8  | 9  | 10 | 11 | 12  | 14  | 15  | 16  | 17  | 18  | 19  | 21  |     |
| 190          | 86  | 0   | 1 | 3  | 4  | 5  | 6  | 7  | 9  | 10 | 11 | 12 | 13  | 14  | 16  | 17  | 18  | 19  | 20  | 21  |     |
| 200          | 91  | 1   | 2 | 3  | 5  | 6  | 7  | 8  | 9  | 10 | 12 | 13 | 14  | 15  | 16  | 17  | 19  | 20  | 21  | 22  |     |
| 210          | 95  | 2   | 3 | 4  | 5  | 7  | 8  | 9  | 10 | 11 | 12 | 14 | 15  | 16  | 17  | 18  | 19  | 21  | 22  | 23  |     |
| 220          | 100 | 3   | 4 | 5  | 6  | 7  | 8  | 10 | 11 | 12 | 13 | 14 | 16  | 17  | 18  | 19  | 20  | 21  | 23  | -   |     |
| 230          | 104 | 3   | 4 | 6  | 7  | 8  | 9  | 10 | 12 | 13 | 14 | 15 | 16  | 17  | 19  | 20  | 21  | 22  | 23  | -   |     |
| 240          | 109 | 4   | 5 | 6  | 8  | 9  | 10 | 11 | 12 | 13 | 15 | 16 | 17  | 18  | 19  | 21  | 22  | 23  | -   | -   |     |
| 250          | 113 | 5   | 6 | 7  | 8  | 10 | 11 | 12 | 13 | 14 | 15 | 17 | 18  | 19  | 20  | 21  | 22  | 23  | -   | -   |     |
| 260          | 118 | 6   | 7 | 8  | 9  | 10 | 11 | 13 | 14 | 15 | 16 | 17 | 19  | 20  | 21  | 22  | 23  | -   | -   | -   |     |
| 270          | 122 | 6   | 8 | 9  | 10 | 11 | 12 | 13 | 15 | 16 | 17 | 18 | 19  | 20  | 22  | 23  | -   | -   | -   | -   |     |



## LEAK CHECK

---

1. Check exhaust system for obvious signs of leakage such as carbon tracks and marks at pipe joints.
  - a. Check for loose or missing fasteners.
  - b. Check for cracked pipe clamps or brackets.
  - c. Check for loose or cracked exhaust shields.
2. Check exhaust system for audible signs of leakage.
  - a. Start engine.
  - b. Cover end of muffler with clean, dry shop towel.
  - c. Listen for signs of exhaust leakage.
3. Correct any detected leaks.
  - a. See EXHAUST SYSTEM (Page 6-34). Disassemble exhaust system.
  - b. Clean all mating surfaces.
  - c. Repair or replace damaged components.
  - d. Assemble exhaust system.

### NOTE

*If leak continues, disassemble and apply PERMATEX ULTRA COPPER or LOCTITE 5920 FLANGE SEALANT or equivalent oxygen sensor/catalyst-safe alternative to mating surfaces.*

## REMOVE \_\_\_\_\_

### Standard

1. See Figure 2-41. Remove air cleaner cover.
  - a. Remove screw (1).
  - b. Remove cover (2).
2. Remove filter element.
  - a. Remove screws (3).
  - b. Remove filter element (4) while pulling breather tube (5) from element.

### Oval

1. See Figure 2-42. Remove air cleaner insert.
  - a. Remove screws (1).
  - b. Remove insert (2).
2. Remove filter element.
  - a. Remove screws (3).
  - b. Remove cover (4) and filter element (5).

## CLEAN AND INSPECT \_\_\_\_\_

### A WARNING

Do not use gasoline or solvents to clean filter element. Flammable cleaning agents can cause an intake system fire, which could result in death or serious injury. (00101a)

### A WARNING

Compressed air can pierce the skin and flying debris from compressed air could cause serious eye injury. Wear safety glasses when working with compressed air. Never use your hand to check for air leaks or to determine air flow rates. (00061a)

1. Standard: See Figure 2-41. Remove breather tube assembly (5) from breather bolts.
2. Oval: See Figure 2-42. Remove breather tubes (6) from breather bolts.
3. Inspect breather tubes for damage.

### NOTE

- Do not strike filter element on a hard surface to dislodge dirt.
  - Do not use air cleaner filter oil on the Harley-Davidson paper/wire mesh air filter element.
4. Clean filter element.

- a. Wash filter element and breather tubes in lukewarm

water with a mild detergent.

- b. Allow filter element to air dry or use low-pressure compressed air from the inside.
  - c. Hold filter element up to a strong light source. The element is sufficiently clean when light is uniformly visible through the media.
  - d. Replace filter element if damaged or if filter media cannot be adequately cleaned.
5. Standard: Verify that rubber seal (6) is properly seated and not damaged.

## INSTALL

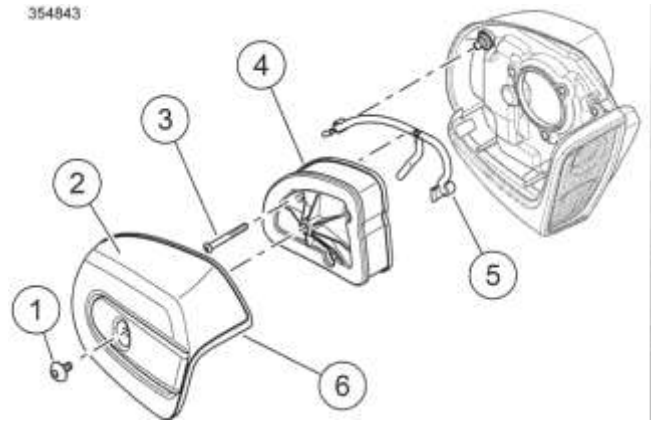
| FASTENER                            |              | TORQUE VALUE  |  |
|-------------------------------------|--------------|---|--|
| Air cleaner cover screw             | 36-60 in-lbs | 4.1-6.8 N-m   |  |
| Air cleaner insert screws           | 27-32 in-lbs | 3.1-3.6 N-m   |  |
| Air filter element screws, oval     | 50-60 in-lbs | 5.6-6.8 N-m   |  |
| Air filter element screws, standard | 40-60 in-lbs | 4.5-6.8 N-m   |  |
| PART NUMBER                         |              | CONSUMABLE  |  |
| 99642-97                            |              | LOCTITE 243 MEDIUM STRENGTH THREADLOCKER AND SEALANT (BLUE) |  |

### Standard

1. See Figure 2-41. Install filter element.
  - a. Install breather tube (5).
  - b. Install filter element (4) while pushing breather tube into element.
  - c. Install screws (3). Tighten.  
Torque: 40-60 in-lbs (4.5-6.8 N-m) *Air filter element screws, standard*
2. Install cover.
  - a. Apply medium threadlocker to screw (1).  
LOCTITE 243 MEDIUM STRENGTH THREADLOCKER AND SEALANT (BLUE) (99642-97)
  - b. Install cover (2).
  - c. Install screw (1). Tighten.  
Torque: 36-60 in-lbs (4.1-6.8 N-m) *Air cleaner cover screw*

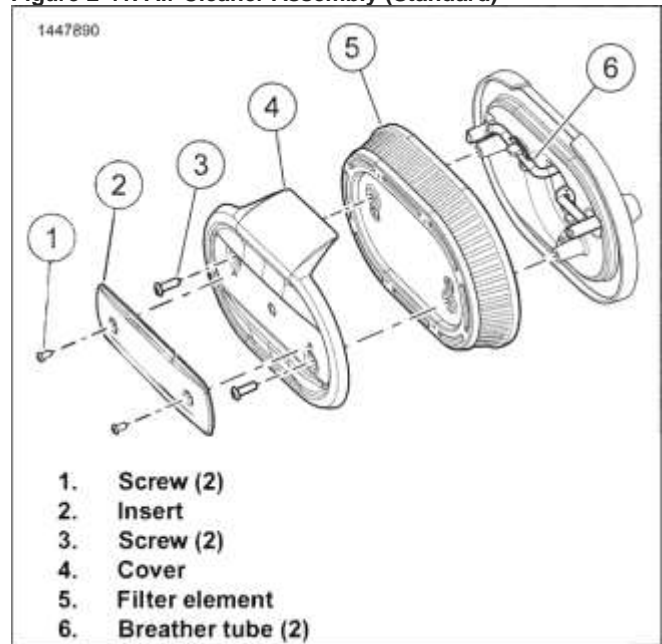
## Oval

1. See Figure 2-42. Install filter element.
  - a. Apply medium threadlocker to screws (3).  
LOCTITE 243 MEDIUM STRENGTH  
THREADLOCKER AND SEALANT (BLUE) (99642-97)
  - b. Secure air filter element (5) and cover (4) with screws (3).
  - c. Tighten screws.  
Torque: 50-60 **in-lbs** (5.6-6.8 N-m) *Air filter element screws, oval*
2. Install insert.
  - a. Secure insert (2) with screws (1).
  - b. Tighten screws.  
Torque: 27-32 **in-lbs** (3.1-3.6 N-m) *Air cleaner insert screws*



1. Cover screw
2. Cover
3. Screw (3)
4. Filter element
5. Breather tube assembly
6. Rubber seal

Figure 2-41. Air Cleaner Assembly (Standard)



1. Screw (2)
2. Insert
3. Screw (2)
4. Cover
5. Filter element
6. Breather tube (2)

Figure 2-42. Air Filter Element (Oval)

## PREPARE

1. Remove seat. See SEAT (Page 3-148).
2. Move top caddy away from battery. See TOP CADDY (Page 8-107).

## REMOVE

1. See Figure 2-43. Disconnect both battery cables (2, 3), negative cable first.
2. Pull up on battery strap (1) to raise battery.
3. Remove battery.

## INSTALL

| FASTENER              | TORQUE VALUE |             |
|-----------------------|--------------|-------------|
| Battery cables screws | 60-70 in-lbs | 6.8-7.9 N-m |

| PART NUMBER | CONSUMABLE                   |
|-------------|------------------------------|
| 11300004    | ELECTRICAL CONTACT LUBRICANT |

1. Run battery strap rearward across bottom of battery tray, then up and across the frame crossmember.
2. See Figure 2-43. Place battery into battery tray, terminal side forward.

### A WARNING

Connect positive (+) battery cable first. If positive (+) cable should contact ground with negative (-) cable connected, the resulting sparks can cause a battery explosion, which could result in death or serious injury. (00068a)

### NOTICE

Connect the cables to the correct battery terminals. Failure to do so could result in damage to the motorcycle electrical system. (00215a)

### NOTICE

Do not over-tighten bolts on battery terminals. Use recommended torque values. Over-tightening battery terminal bolts could result in damage to battery terminals. (00216a)

3. Connect both battery cables, positive battery cable first. Tighten.

Torque: 60-70 in-lbs (6.8-7.9 N-m) *Battery cables screws*

### NOTICE

Keep battery clean and lightly coat terminals with petroleum jelly to prevent corrosion. Failure to do so could result in damage to battery terminals. (00217a)

4. Apply a light coat of petroleum or electrical contact lubricant to both battery terminals.  
Consumable: ELECTRICAL CONTACT LUBRICANT (11300004)
5. Fold battery strap over top of battery.

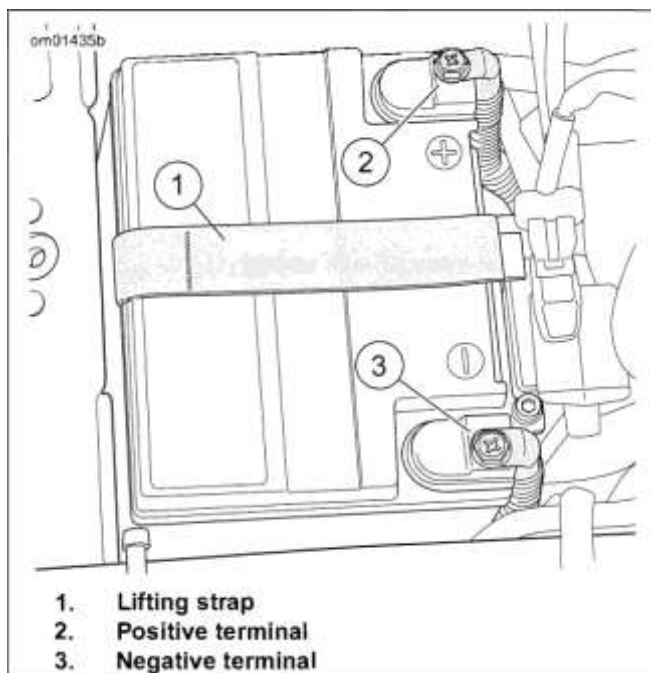


Figure 2-43. Battery Compartment

## CLEAN AND INSPECT

### NOTE

*Battery top must be clean and dry. Dirt and electrolyte on top of the battery causes self-discharge.*

1. Clean battery top.
  - a. Mix a solution of five teaspoons of baking soda (sodium bicarbonate) per liter or quart of water.
  - b. Apply to battery top.
2. When the solution stops bubbling, rinse off battery with clean water.
3. Clean cable connectors and battery terminals with a wire brush or sandpaper. Remove any oxidation.
4. Inspect the battery terminal screws and cables for breakage, loose connections and corrosion.
5. Check the battery terminals for melting or damage.
6. Inspect the battery for discoloration, raised top or a warped or distorted case. Replace as necessary.
7. Inspect the battery case for cracks or leaks.

## VOLTAGE TEST

The voltage test provides a general indicator of battery condition. Check the voltage of the battery to verify that it is fully charged. Refer to Table 2-22.

1. If the open circuit (disconnected) voltage reading is below 12.6 V:
  - a. Charge the battery.
  - b. Check the voltage after the battery has set for at least one hour.
2. If the voltage reading is 12.7 V or above:
  - a. Perform a battery diagnostic test. See the electrical diagnostic manual for the load test procedure.

**Table 2-22. Voltage Test For Battery Charge Conditions**

| VOLTAGE (OCV) | STATE OF CHARGE |
|---------------|-----------------|
| 12.7 V        | 100%            |
| 12.6 V        | 75%             |
| 12.3 V        | 50%             |
| 12.0 V        | 25%             |
| 11.8 V        | 0%              |

### STORAGE

See Figure 2-44. A battery is affected by self-discharge whether stored in or out of the vehicle. A battery that is stored in the vehicle is also affected by parasitic loads. A parasitic load is caused by things like diode leakage or maintaining computer memory with the vehicle turned off.

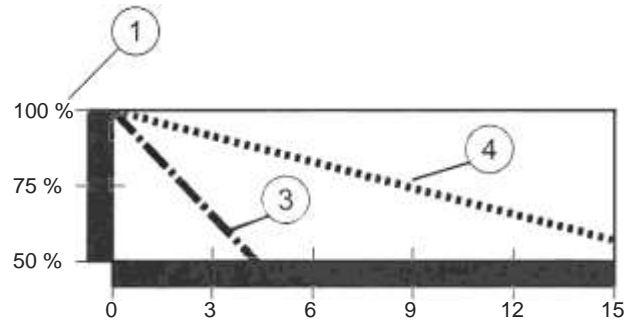
Batteries self-discharge at a faster rate at higher ambient temperatures. Store battery in a cool, dry place to reduce the self-discharge rate.

Charge the battery every two weeks if stored in the vehicle.  
 Charge the battery once per month if removed the vehicle.

### NOTE

Use a Harley-Davidson constant monitoring battery charger/tender to maintain batteiy charge for extended periods of time without risk of overcharging or boiling.

om00036



1. Capacity
2. Months of non-use
3. Measured at 40 °C (105 °F)
4. Measured at 25 °C (77 °F)

**Figure 2-44. Effective Rate of Temperature on Battery Self-discharging Rate**

### COMPLETE

1. Install top caddy. See TOP CADDY (Page 8-107)
2. Install seat. See SEAT (Page 3-148).

**PREPARE** \_\_\_\_\_

1. Remove main fuse. See POWER DISCONNECT (Page 8-8).

**NOTE**

Fuel tank removal improves access to the right spark plugs.

2. Remove fuel tank. See FUEL TANK (Page 6-10).

**REMOVE** \_\_\_\_\_

| PART NUMBER | TOOL NAME                         |
|-------------|-----------------------------------|
| HD-52006    | ADJUSTABLE SPARK PLUG WIRE PULLER |

**A WARNING**

Disconnecting spark plug cable with engine running can result in electric shock and death or serious injury. (00464b)

**NOTE**

- Never remove spark plugs until heads have cooled.
- Use ADJUSTABLE SPARK PLUG WIRE PULLER (PART NUMBER: HD-52006) to remove stubborn spark plug boots.

1. Disconnect spark plug cables.
2. Remove spark plugs.

**CLEAN AND INSPECT** \_\_\_\_\_

**NOTE**

Discard plugs with eroded electrodes, heavy deposits or a cracked insulator.

See Figure 2-45. Compare plug deposits to Table 2-23.



Figure 2-45. Spark Plug Deposits

**INSTALL**

1. Verify proper gap before installing **new** or cleaned spark

**Table 2-23. Spark Plug Deposit Analysis**

| PLUG | DEPOSITS  | POSSIBLE CAUSE  |
|------|---|---|
| 1    | Wet, black and shiny  | Worn pistons<br>Worn piston rings<br>Worn valves<br>Worn valve guides<br>Worn valve seals<br>Weak battery<br>Faulty ignition system |
| 2    | Dry, fluffy or sooty and black  | Air-fuel mixture too rich   |
| 3    | Light brown and glassy*<br>May be accompanied by cracks in the insulator or by electrode erosion. | Air-fuel mixture too lean<br>Hot running engine<br>Valves not seating<br>Improper ignition timing                                   |
| 4    | White, gray or tan and powdery  | Balanced combustion<br>Clean off deposits at regular intervals.   |

\* The glassy deposit on a spark plug may cause high-speed misfiring.

- a. Select a wire-type feeler gauge within specification. Refer

| FASTENER   | TORQUE VALUE  |           |
|------------|---------------|-----------|
| Spark plug | 89-133 in-lbs | 10-15 N-m |

to Table 2-24.

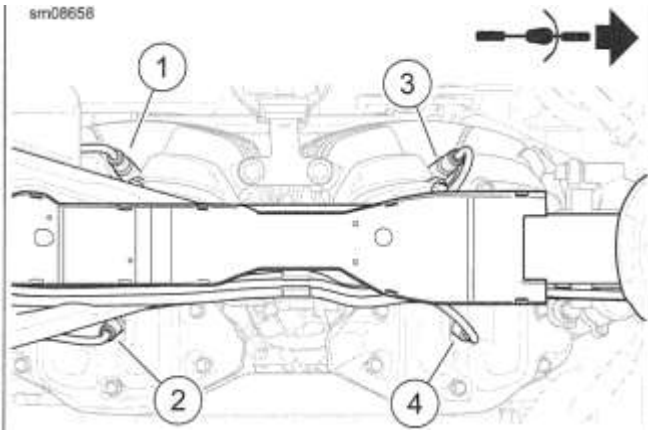
- b. Pass the wire gauge between the electrodes.
- c. Use the proper tool to bend the outer electrode to bring the gap to within specification.

2. Verify that spark plug threads are clean and dry.
3. Install spark plug. Tighten. Refer to Table 2-24.
4. See Figure 2-46. Connect spark plug cables. Check connections at coil, spark plugs and anchor clips or harness caddies.

**Table 2-24. Spark Plug**

| MODELS     | TYPE    | GAP                         | TORQUE                       |
|------------|---------|-----------------------------|------------------------------|
| All Models | HD-6R10 | 0.031-0.035 in<br>(0.8-0.9) | 89-133 in-lbs<br>(10-15 N-m) |

sm08658



**COMPLETE**

1. Install fuel tank. See FUEL TANK (Page 6-10).
2. Install main fuse. See POWER DISCONNECT (Page 8-8).

1. **Left rear**
2. **Right rear**
3. **Left front**
4. **Right front**

**Figure 2-46. Spark Plug Cables**

**PLACE IN STORAGE****A WARNING**

Do not store motorcycle with gasoline in tank within the home or garage where open flames, pilot lights, sparks or electric motors are present. Gasoline is extremely flammable and highly explosive, which could result in death or serious injury. (00003a)

1. Change engine oil and filter. See REPLACE ENGINE OIL AND FILTER (Page 2-9).
2. Check transmission lubricant level. See REPLACE TRANSMISSION LUBRICANT (Page 2-13).

**A WARNING**

Avoid spills. Slowly open fuel filler cap. Do not fill above bottom of filler neck insert, leaving air space for fuel expansion. Secure filler cap after refueling. Gasoline is extremely flammable and highly explosive, which could result in death or serious injury. (00028b)

**A WARNING**

Use care when refueling. Pressurized air in fuel tank can force gasoline to escape through filler tube. Gasoline is extremely flammable and highly explosive, which could result in death or serious injury. (00029a)

1. Prepare fuel tank.
  - a. Fill fuel tank.
  - b. Add fuel stabilizer.
2. Lubricate cylinders.
  - a. Remove spark plugs. See CLEAN AND INSPECT SPARK PLUGS (Page 2-50).
  - b. Inject a few squirts of engine oil into each cylinder.
  - c. Crank engine for 5-6 revolutions.
  - d. Install spark plugs. See CLEAN AND INSPECT SPARK PLUGS (Page 2-50).
3. Inspect drive belt deflection. See INSPECT AND ADJUST DRIVE BELT AND SPROCKETS (Page 2-37).
4. Inspect drive belt and sprockets. See INSPECT AND ADJUST DRIVE BELT AND SPROCKETS (Page 2-37).
5. Inspect air cleaner filter. See INSPECT AIR FILTER (Page 2-46).
6. Lubricate controls. See LUBRICATE CABLES AND CHASSIS (Page 2-18).

7. Check tire inflation and inspect tires for wear and/or damage. See INSPECT TIRES AND WHEELS (Page 2-15).
8. If the motorcycle will be stored for an extended period of time, securely support the motorcycle under the frame so that all weight is off the tires.
9. Inspect operation of all electrical equipment and switches.

**A WARNING**

Be sure that brake fluid or other lubricants do not contact brake pads or discs. Such contact can adversely affect braking ability, which could cause loss of control, resulting in death or serious injury. (00290a)

1. Wash painted and chrome-plated surfaces. Apply a light film of oil to exposed unpainted surfaces.

**A WARNING**

Unplug or turn OFF battery charger before connecting charger cables to battery. Connecting cables with charger ON can cause a spark and battery explosion, which could result in death or serious injury. (00066a)

**A WARNING**

Explosive hydrogen gas, which escapes during charging, could cause death or serious injury. Charge battery in a well-ventilated area. Keep open flames, electrical sparks and smoking materials away from battery at all times. KEEP BATTERIES AWAY FROM CHILDREN. (00065a)

1. Battery maintenance.
  - a. Remove battery from vehicle. See INSPECT BATTERY (Page 2-48).
  - b. Charge battery until the correct voltage is obtained.
  - c. Charge the battery every other month if it is stored at temperatures below specification.  
Temperature: 60 °F (16 °C)
2. Charge battery once a month if it is stored at temperatures above specification.  
Temperature: 60 °F (16 °C)

**A WARNING**

Unplug or turn OFF battery charger before disconnecting charger cables from battery. Disconnecting clamps with charger ON can cause a spark and battery explosion, which could result in death or serious injury. (00067a)

1. Covering the motorcycle.
  - a. If the motorcycle is to be covered, use a material that will breathe, such as a Harley-Davidson storage cover or light canvas.



b. Plastic materials that do not breathe promote the formation of condensation, which leads to corrosion.

## **REMOVE FROM STORAGE** \_\_\_\_\_

### **A WARNING**

**The clutch failing to disengage can cause loss of control, which could result in death or serious injury. Prior to starting after extended periods of storage, place transmission in gear and push vehicle back and forth several times to assure proper clutch disengagement. (00075a)**

1. Charge battery.
2. Install battery. See INSPECT BATTERY (Page 2-48).
3. Inspect spark plugs. See CLEAN AND INSPECT SPARK PLUGS (Page 2-50).
4. Fill fuel tank, if empty.
5. Start engine. Run until it reaches normal operating temperature.
6. Check engine oil level. See REPLACE ENGINE OIL AND FILTER (Page 2-9).
7. Check transmission lubricant level. See REPLACE TRANSMISSION LUBRICANT (Page 2-13).
8. Perform all of the checks in the PRE-RIDING CHECKLIST in the owner's manual.

## GENERAL

**A WARNING**

**The Troubleshooting section of this manual is a guide to diagnose problems. Read the appropriate sections of this manual before performing any work. Improper repair and/or maintenance could result in death or serious injury. (00528b)**

Use the symptoms listed for general troubleshooting. More than one condition may be present at a time. Check all possible items to keep motorcycle in good operating condition.

## NOTE

- See the electrical diagnostic manual for additional information.
- See *DIAGNOSE AND TEST (Page 7-5)* for additional cooling system troubleshooting.

## ENGINE

**Starter Motor Does Not Operate or Does Not Turn Engine Over**

1. Ignition switch not in IGNITION position.
2. Engine run switch in OFF position.
3. Discharged battery, loose or corroded connections (solenoid chatters).
4. Starter control circuit, relay or solenoid faulty.
5. Electric starter shaft pinion gear not engaging or overrunning clutch slipping.
6. TSM/TSSM/HFSM Bank Angle Sensor tripped and ignition/light key switch not cycled OFF then back to IGNITION.
7. Security system activated.
8. Motorcycle in gear and clutch not pulled in.
9. Jiffy stand down and transmission in gear (HDI models only).
10. Main fuse not in place.

**Engine Turns Over But Does Not Start**

1. Fuel tank empty.
2. Fouled spark plugs.
3. Discharged battery, loose or damaged battery terminal connections.
4. Engine lubricant too heavy (winter operation).

## NOTE

*For cold-weather starts, always disengage clutch.*

5. Spark plug cables in bad condition and shorting, cable connections loose or cables connected to incorrect cylinders.
6. Damaged wire or loose wire connection at ignition coil, battery or ECM connector.
7. Ignition timing incorrect due to faulty ignition coil, ECM or sensors (follow any current DTC's in order of priority).
8. Bank Angle Sensor tripped and ignition switch not cycled

OFF then back to IGNITION.

9. Fuel filter clogged (verify fuel pressure meets specification).
10. Sticking or damaged valve(s) or wrong length pushrod(s) (verify leak down and compression meet specifications).
11. Plugged fuel injectors.

**Starts Hard**

1. Spark plugs in bad condition or have improper gap or are partially fouled.
2. Spark plug cables in poor condition.
3. Battery nearly discharged.
4. Damaged wire or loose wire connection at ignition coil, battery or ECM connector.
5. Water or dirt in fuel system.
6. Intake air leak.
7. Fuel tank vent hose, filler cap vent or vapor valve plugged, or fuel line closed off, restricting fuel flow.
8. Engine lubricant too heavy (winter operation).

## NOTE

*For cold-weather starts, always disengage clutch.*

9. Ignition not functioning properly (possible sensor failure).
10. Faulty ignition coil.
11. Valves sticking.
12. Partially plugged fuel injector(s).

**Starts But Runs Irregularly or Misses**

1. Spark plugs in poor condition or partially fouled.
2. Spark plug cables in poor condition and shorting or leaking.
3. Spark plug gap too close or too wide.
4. Faulty ignition coil, ECM or sensor (follow any current DTC's in order of priority).
5. Battery nearly discharged.
6. Damaged wire or loose wire connection at ignition coil, battery or ECM connector.
7. Intermittent short circuit due to damaged wire insulation.
8. Water or dirt in fuel system.
9. Fuel tank vent system plugged.
10. Air leak at intake manifold or air cleaner.
11. Loose or dirty ECM connector.
12. Faulty Sensor(s): Temperature Manifold Absolute Pressure (TMAP), Crank Position (CKP) or Oxygen (O2) (follow any current DTC's in order of priority. Monitor scan values of sensors in Digital Technician).
13. Incorrect valve timing.
14. Weak or damaged valve springs.

15. Damaged intake or exhaust valve (verify leak down and compression meet specifications).
16. Partially plugged fuel injector(s).

### A Spark Plug Fouls Repeatedly

1. Fuel mixture too rich.
2. Incorrect spark plug for the kind of service.
3. Piston rings badly worn or damaged.
4. Valve guides or seals badly worn.

### Pre-Ignition or Detonation (Knocks or Pings)

1. Fuel octane rating too low.
2. Faulty spark plugs.
3. Incorrect spark plug for the kind of service.
4. Excessive carbon deposit on piston head or in combustion chamber.
5. Ignition timing advanced due to faulty sensor inputs (TMAP and/or CKP).
6. Ignition timing advanced due to ECM or sensors (CKP, ET or TMAP) defective.
7. Intake manifold vacuum leak.

### Overheating

1. Insufficient oil supply or oil not circulating.
2. Insufficient air flow over engine.
3. Heavy carbon deposits.
4. Ignition timing retarded due to defective ECM or faulty sensor(s) (TMAP and/or CKP).
5. Leaking valve(s).
6. Low coolant level. \*
7. Restricted radiator air flow. \*
8. Coolant pump or fans inoperative. \*
9. Vent hose crimped. \*
10. Air in coolant. \*

\* Twin-Cooled only

### Valve Train Noise

#### NOTE

*Some valve train noise at start-up is normal until lifters fill with oil.*

1. Low oil pressure caused by oil feed pump not functioning properly or oil passages obstructed.
2. Faulty hydraulic lifter(s).
3. Bent pushrod(s).
4. Incorrect pushrod length.
5. Rocker arm binding on shaft.
6. Valve sticking in guide.
7. Chain tensioning spring or shoe worn.
8. Cam(s), cam gear(s) or cam bushing(s) worn.
9. Cam timing incorrect.
10. Valve seat loose in head.

11. Cam bearing in crankcase or cam support plate clearance excessive.

### Excessive Vibration

1. Wheels bent or damaged and/or tires worn or damaged.
2. Engine/Transmission/Rear Wheel not aligned properly.
3. Primary chain badly worn or links tight as a result of insufficient lubrication or misalignment.
4. Engine to transmission mounting bolts loose.
5. Upper engine mounting bracket loose/damaged or mounting bracket pre-loaded.
6. Ignition timing advanced due to faulty sensor inputs (TMAP and/or CKP)/poorly tuned engine.
7. Internal engine problem.
8. Damaged frame.
9. Stabilizer links worn or loose, or stabilizer link brackets loose or damaged.
10. Rubber mount (front) snubbers not centered and contacting side of mount.
11. Rubber mounts (front or rear) loose or worn.
12. Rear fork pivot shaft fasteners loose.
13. Front engine mount bracket bolts loose.
14. Exhaust system binding and causing unnecessary side loads.

### Check Engine Light Illuminates During Operation

Fault detected. For diagnostic information see the electrical diagnostic manual.

### LUBRICATION SYSTEM

#### Oil Does Not Return To Oil Reservoir

1. Oil reservoir empty.
2. Oil pump not functioning.
3. Restricted oil lines or fittings.
4. Restricted oil filter.
5. O-ring damaged or missing from oil pump/crankcase junction (also results in poor engine performance).

#### Engine Uses Too Much Oil Or Smokes Excessively

1. Oil reservoir overfilled.
2. Restricted oil return line to oil reservoir.
3. Restricted breather operation.
4. Restricted oil filter.
5. Oil pump misaligned or in poor condition.
6. Piston rings badly worn or broken.
7. Valve guides or seals worn or damaged.
8. O-ring damaged or missing from oil pump/crankcase junction (also results in poor engine performance).
9. Plugged crankcase scavenge port.
10. Oil diluted with gasoline.

## **Engine Leaks Oil From Cases, Pushrods, Hoses, Etc.**

1. Loose parts.
2. Imperfect seal at gaskets, pushrod covers, washers, etc.
3. Restricted breather passages or hose to air cleaner.
4. Restricted oil filter.
5. Oil reservoir overfilled.
6. Lower rocker housing gasket installed incorrectly (upside down).
7. Restricted oil return line to oil reservoir.
8. Porosity.

## **Low Oil Pressure**

1. Oil reservoir underfilled.
2. Faulty low oil pressure switch.
3. Oil pump O-ring damaged or missing.
4. Bypass valve stuck in open position.
5. Ball missing or leaking in cam support plate.
6. Worn oil pump gerotor(s).
7. Oil diluted with gasoline.

## **High Oil Pressure**

1. Oil reservoir overfilled.
2. Bypass valve stuck in closed position.

## **ELECTRICAL SYSTEM**

---

### *NOTE*

*For diagnostic information see the electrical diagnostic manual.*

## **Alternator Does Not Charge**

1. Voltage regulator module not grounded.
2. Engine ground wire loose or damaged.
3. Faulty voltage regulator module.
4. Loose or damaged wires in charging circuit.
5. Faulty stator and/or rotor.

## **Alternator Charge Rate Is Below Normal**

1. Weak or damaged battery.
2. Loose connections.
3. Faulty voltage regulator module.
4. Faulty stator and/or rotor.

## **Speedometer Operates Erratically**

1. Loose connections.

## **TRANSMISSION**

---

## **Shifts Hard**

1. Primary chaincase overfilled.
2. Clutch not fully disengaging.
3. Transmission lubricant too heavy (winter operation).
4. Shifter return spring (inside transmission) bent or otherwise damaged.

5. Bent shifter rod.
6. Shifter forks sprung.
7. Corners worn off shifter clutch dog rings (inside transmission).

## **Jumps Out Of Gear**

1. Shifter rod improperly adjusted.
2. Shifter drum improperly adjusted or damaged/worn.
3. Shifter engaging parts badly worn and rounded.
4. Bent shifter forks .
5. Damaged gears.

## **Clutch Slips**

1. Clutch lever not returning completely.
2. Damaged or binding secondary clutch actuator.
3. Insufficient clutch spring tension.
4. Worn friction discs.

## **Clutch Drags Or Does Not Release**

1. Lubricant level too high in primary chaincase.
2. Clutch improperly adjusted.
3. Primary chain badly misaligned or too tight.
4. Insufficient clutch spring tension.
5. Clutch discs warped.

## **Clutch Chatters**

Friction discs or steel discs worn or warped.

## **HANDLING**

---

## **Irregularities**

1. Improperly loaded motorcycle. Non-standard equipment such as heavy radio receivers, extra lighting equipment excess or unsecured luggage may cause unstable handling.
2. Load (people and gear) exceeds maximum GVWR.
3. Damaged tire(s) or improper front-rear tire combination.
4. Irregular or peaked front tire tread wear.
5. Incorrect tire pressure.
6. Shock absorber not functioning normally.
7. Incorrect suspension adjustment.
8. Loose wheel axle nuts. Tighten to recommended torque specification.
9. Excessive wheel hub bearing play.
10. Rear wheel out of alignment with frame and front wheel.
11. Steering head bearings improperly adjusted. Correct adjustment and replace pitted or worn bearings and races.
12. Loose spokes (laced wheel vehicles only).
13. Tire and wheel unbalanced.
14. Rims and tires out-of-round or eccentric with hub.
15. Rims and tires out-of-true sideways.
16. Rear fork pivot assembly: improperly tightened or assembled, or loose/pitted or damaged pivot bearings.

17. Engine mounts and/or stabilizer links loose, worn or damaged.
18. Incorrect, non-specified tire mounted on front or rear wheel.

## **BRAKES**

---

### **Brake Does Not Hold Normally**

1. Brake fluid reservoir low, system leaking or pads worn.
2. Brake system contains air bubbles.
3. Master cylinder/caliper piston seals worn or parts damaged.
4. Brake pads contaminated with grease or oil.
5. Brake pads badly worn.
6. Brake disc badly worn or warped.
7. Brake drags - insufficient brake pedal or hand lever free play, caliper piston worn or damaged, or excessive brake fluid in reservoir.
8. Brake fades due to heat build up - brake pads dragging or excessive braking.
9. Brake fluid leak when under pressure.



## NOTES

| SUBJECT   | PAGE NO. |
|---|----------|
| 3.1 FASTENER TORQUE VALUES .....                                | 3-1      |
| 3.2 SPECIFICATIONS .....  | 3-8      |
| 3.3 VEHICLE IDENTIFICATION NUMBER (VIN).....                    | 3-10     |
| 3.4 FRONT WHEEL .....   | 3-12     |
| 3.5 REAR WHEEL .....  | 3-14     |
| 3.6 WHEEL LACING .....  | 3-17     |
| 3.7 CHECKING AND TRUING WHEELS .....                            | 3-22     |
| 3.8 REAR WHEEL COMPENSATOR.....                                 | 3-24     |
| 3.9 SEALED WHEEL BEARINGS .....                                 | 3-26     |
| 3.10 TIRE PRESSURE MONITORING SYSTEM (TPMS) .....               | 3-29     |
| 3.11 TIRES .....  | 3-31     |
| 3.12 ELECTRONIC CHASSIS CONTROL .....                           | 3-36     |
| 3.13 FRONT BRAKE MASTER CYLINDER .....                          | 3-37     |
| 3.14 FRONT BRAKE CALIPER .....                                  | 3-40     |
| 3.15 REAR BRAKE MASTER CYLINDER .....                           | 3-42     |
| 3.16 REAR BRAKE CALIPER.....                                    | 3-45     |
| 3.17 PARKING BRAKE ASSEMBLY.....                                | 3-46     |
| 3.18 BRAKE LINES .....  | 3-48     |
| 3.19 ABS MODULE .....   | 3-58     |
| 3.20 BLEED BRAKES.....  | 3-60     |
| 3.21 LEFT SIDE COVER .....                                      | 3-62     |
| 3.22 RIGHT SIDE COVER.....                                      | 3-63     |
| 3.23 FRONT FORK.....  | 3-64     |
| 3.24 STEERING HEAD/FORK STEM AND BRACKET ASSEMBLY .....         | 3-71     |
| 3.25 REAR FORK .....  | 3-75     |
| 3.26 BELT GUARDS.....   | 3-79     |
| 3.27 REAR SHOCK ABSORBERS .....                                 | 3-80     |
| 3.28 CLUTCH CONTROL .....                                       | 3-81     |
| 3.29 HEADLAMP NACELLE .....                                     | 3-87     |
| 3.30 FAIRING: FORK MOUNTED.....                                 | 3-89     |
| 3.31 FAIRING: FRAME MOUNTED .....                               | 3-100    |
| 3.32 FAIRING LOWERS .....                                       | 3-113    |
| 3.33 ENGINE GUARD .....   | 3-118    |
| 3.34 AIR DEFLECTORS.....  | 3-119    |
| 3.35 WINDSHIELD .....   | 3-121    |
| 3.36 HAND GRIPS .....   | 3-123    |
| 3.37 HANDLEBAR .....  | 3-125    |
| 3.38 MIRRORS.....   | 3-132    |
| 3.39 FRONT FENDER.....  | 3-134    |
| 3.40 REAR FENDER .....  | 3-137    |
| 3.41 REAR FENDER WIRE CONDUIT.....                              | 3-140    |
| 3.42 REAR LICENSE PLATE BRACKET.....                            | 3-141    |
| 3.43 RIDER FOOTRESTS .....                                      | 3-142    |
| 3.44 PASSENGER FOOTRESTS .....                                  | 3-144    |
| 3.45 JIFFY STAND .....  | 3-146    |
| 3.46 SEAT .....   | 3-148    |
| 3.47 REAR FRAME .....   | 3-151    |
| 3.48 TOUR-PAK .....   | 3-153    |
| 3.49 TOUR-PAK SUPPORT .....                                     | 3-159    |
| 3.50 SADDLEBAGS .....   | 3-161    |
| 3.51 SADDLEBAG SUPPORTS .....                                   | 3-165    |
| 3.52 MEDALLIONS, BADGES, TANK EMBLEMS AND ADHESIVE STRIPS ..... | 3-167    |



## NOTES



## FASTENER TORQUE VALUES IN THIS CHAPTER \_\_\_\_\_

| FASTENER   | TORQUE VALUE                     |               | NOTES   |
|--|----------------------------------|---------------|---|
|  | 30.0-40.0 ft-lbs   40.7-54.2 N-m |               | 3.37 HANDLEBAR, Disassemble and Assemble                          |
| ABS module banjo bolt                                | 28-30 ft-lbs                     | 38-40.6 N-m   | 3.18 BRAKE LINES, Brake Line: Front Master Cylinder to ABS Module |
| ABS module banjo bolt                                | 17-19 ft-lbs                     | 23.1-25.8 N-m | 3.18 BRAKE LINES, Brake Line: Front Caliper to ABS Module         |
| ABS module locknuts                                  | 53-89 in-lbs                     | 6-10 N-m      | 3.19 ABS MODULE, Install  |
| Banjo bolt to ABS module, 10 mm                      | 17-19 ft-lbs                     | 23.1-25.8 N-m | 3.19 ABS MODULE, Install  |
| Banjo bolt to ABS module, 12 mm                      | 28-30 ft-lbs                     | 38-40.6 N-m   | 3.18 BRAKE LINES, Brake Line: Rear Master Cylinder to ABS Module  |
| Banjo bolt to ABS module, 12 mm                      | 28-30 ft-lbs                     | 38-40.6 N-m   | 3.19 ABS MODULE, Install  |
| Banjo bolt to ABS module, mm                         | 17.0-19.0 ft-lbs                 | 23.1-25.8 N-m | 3.18 BRAKE LINES, Brake Line: Rear Caliper to ABS Module          |
| Banjo bolt to rear caliper                           | 17.0-19.0 ft-lbs                 | 23.1-25.8 N-m | 3.18 BRAKE LINES, Brake Line: Rear Caliper to ABS Module          |
| Banjo bolt to rear master cylinder                   | 17 ft-lbs                        | 23.1 N-m      | 3.18 BRAKE LINES, Brake Line: Rear Master Cylinder to ABS Module  |
| Battery tray screws                                  | 132-156 in-lbs                   | 14.9-17.6 N-m | 3.19 ABS MODULE, Install  |
| Brake bleeder screw, front                           | 72-108 in-lbs                    | 8.1-12.2 N-m  | 3.20 BLEED BRAKES, Fill and Bleed                                 |
| Brake bleeder screw, rear                            | 75-102 in-lbs                    | 8.5-11.5 N-m  | 3.20 BLEED BRAKES, Fill and Bleed                                 |
| Brake caliper screw                                  | 43-48 ft-lbs                     | 58-65 N-m     | 3.5 REAR WHEEL, Complete  |
| Brake disc screw, front                              | 16-24 ft-lbs                     | 21.5-32.5 N-m | 3.4 FRONT WHEEL, Assemble<br>Always use new screws                |
| Brake line, rear, P-clamp screw                      | 80-100 in-lbs                    | 9-11.3 N-m    | 3.18 BRAKE LINES, Brake Line: Rear Master Cylinder to ABS Module  |
| Brake line bracket to lower fork bracket screws      | 12-18 in-lbs                     | 1.4-2 N-m     | 3.24 STEERING HEAD/FORK STEM AND BRACKET ASSEMBLY, Install        |
| Brake master cylinder, front, clamp screw            | 60-80 in-lbs                     | 6.8-9 N-m     | 3.37 HANDLEBAR, Remove and Install: Without Fairing               |
| Brake master cylinder, front, clamp screw            | 60-80 in-lbs                     | 6.8-9 N-m     | 3.37 HANDLEBAR, Remove and Install: Fork Mounted Fairing          |
| Brake master cylinder, front, clamp screw            | 60-80 in-lbs                     | 6.8-9 N-m     | 3.37 HANDLEBAR, Remove and Install: Frame Mounted Fairing         |
| Brake master cylinder, front, reservoir cover screws | 12-15 in-lbs                     | 1.4-1.7 N-m   | 3.20 BLEED BRAKES, Fill and Bleed                                 |
| Brake master cylinder, front, reservoir cover screws | 12-15 in-lbs                     | 1.4-1.7 N-m   | 3.20 BLEED BRAKES, Fill and Bleed                                 |
| Brake master cylinder, rear, reservoir cover screws  | 12-15 in-lbs                     | 1.4-1.7 N-m   | 3.20 BLEED BRAKES, Fill and Bleed                                 |
| Brake master cylinder, rear, reservoir cover screws  | 12-15 in-lbs                     | 1.4-1.7 N-m   | 3.20 BLEED BRAKES, Fill and Bleed                                 |
| Brake pedal shaft locknut                            | 180-240 in-lbs                   | 20.3-27.1 N-m | 3.15 REAR BRAKE MASTER CYLINDER, Install                          |
| Clutch hand lever screw                              | 60-80 in-lbs                     | 6.8-9 N-m     | 3.28 CLUTCH CONTROL, Install                                      |
| Clutch lever anti-rattle screw                       | 19-23 in-lbs                     | 2.1-2.6 N-m   | 3.28 CLUTCH CONTROL, Assemble                                     |
| Clutch lever bracket clamp screw                     | 60-80 in-lbs                     | 6.8-9 N-m     | 3.37 HANDLEBAR, Remove and Install: Without Fairing               |
| Clutch lever bracket clamp screw                     | 60-80 in-lbs                     | 6.8-9 N-m     | 3.37 HANDLEBAR, Remove and Install: Fork Mounted Fairing          |

| FASTENER   | TORQUE VALUE  |               | NOTES  |
|--|---------------|---------------|--|
| Clutch lever bracket clamp screw   | 60-80 in-lbs  | 6.8-9 N-m     | 3.37 HANDLEBAR, Remove and Install: Frame Mounted Fairing                  |
| Coolant down tube upper screws (2)   | 90-110 in-lbs | 10.2-12.4 N-m | 3.33 ENGINE GUARD, Install   |
| Debris deflector screw   | 65-85 in-lbs  | 7.3-9.6 N-m   | 3.25 REAR FORK, Complete   |
| Debris deflector screw   | 65-85 in-lbs  | 7.3-9.6 N-m   | 3.26 BELT GUARDS, Install  |
| Engine guard lower screws  | 15-20 ft-lbs  | 20.3-27.1 N-m | 3.33 ENGINE GUARD, Install   |
| Engine guard upper screws  | 22-28 ft-lbs  | 29.8-37.9 N-m | 3.33 ENGINE GUARD, Install   |
| Enginemount end cap screws, front  | 42-48 ft-lbs  | 56.9-65 N-m   | 3.18 BRAKE LINES, Brake Line: Rear Master Cylinder to ABS Module           |
| Fairing air deflector screws: Frame-mounted fairing  | 8-15 in-lbs   | 0.9-1.7 N-m   | 3.31 FAIRING: FRAME MOUNTED, Remove and Install: Storage Compartments      |
| Fairing air deflector screws fork-mounted fairing  | 15-25 in-lbs  | 1.7-2.8 N-m   | 3.34 AIR DEFLECTORS, Remove and Install: Fork Mounted Fairing              |
| Fairing air deflector screws frame-mounted fairing   | 8-15 in-lbs   | 0.9-1.7 N-m   | 3.34 AIR DEFLECTORS, Remove and Install: Frame Mounted Fairing             |
| Fairing gauge screw  | 8-15 in-lbs   | 0.9-1.7 N-m   | 3.31 FAIRING: FRAME MOUNTED, Disassemble and Assemble: Inner Fairing Shell |
| Fairing lower inner panel screws   | 65-75 in-lbs  | 7.3-8.5 N-m   | 3.32 FAIRING LOWERES, Disassemble and Assemble: Air-Cooled                 |
| Fairing mount to steering head locknuts: Frame-mounted fairing                             | 20-30 ft-lbs  | 27.1-40.7 N-m | 3.31 FAIRING: FRAME MOUNTED, Remove and Install: Mounting Bracket          |
| Fairing speaker enclosure to fairing screws  | 48-60 in-lbs  | 5.4-6.8 N-m   | 3.30 FAIRING: FORK MOUNTED, Remove and Install: Fairing                    |
| Fairing speaker enclosure to fairing screws  | 48-60 in-lbs  | 5.4-6.8 N-m   | 3.31 FAIRING: FRAME MOUNTED, Disassemble and Assemble: Inner Fairing Shell |
| Fairing speaker grille screws  | 9-13 in-lbs   | 1-1.5 N-m     | 3.30 FAIRING: FORK MOUNTED, Remove and Install: Fairing                    |
| Fairing support bracket-to-engine guard screws   | 40-50 in-lbs  | 4.5-5.7 N-m   | 3.31 FAIRING: FRAME MOUNTED, Remove and Install: Inner Fairing Shell       |
| Fairing support bracket-to-engine guard screws   | 40-50 in-lbs  | 4.5-5.7 N-m   | 3.31 FAIRING: FRAME MOUNTED, Remove and Install: Storage Compartments      |
| Fairing support bracket-to-inner fairing screws: Frame-mounted fairing                     | 48-60 in-lbs  | 5.4-6.8 N-m   | 3.31 FAIRING: FRAME MOUNTED, Remove and Install: Inner Fairing Shell       |
| Fairing support bracket-to-inner fairing screws: Frame-mounted fairing                     | 48-60 in-lbs  | 5.4-6.8 N-m   | 3.31 FAIRING: FRAME MOUNTED, Remove and Install: Storage Compartments      |
| Fairing vent to inner fairing: fork mounted fairing  | 20-30 in-lbs  | 2.3-3.4 N-m   | 3.30 FAIRING: FORK MOUNTED, Remove and Install: Vent                       |
| Footboard/footpeg lower fastener, passenger: FLH, FLHT, FLHX, FLHXS, FLTRX, FLTRXS, FLHRXS | 48-72 in-lbs  | 5.4-8.1 N-m   | 3.44 PASSENGER FOOTRESTS, Install  |
| Footboard/footpeg upper fastener, passenger:FLH, FLHT, FLHX, FLHXS, FLTRX, FLTRXS, FLHRXS  | 36-42 ft-lbs  | 48.8-56.9 N-m | 3.44 PASSENGER FOOTRESTS, 1 nstall   |
| Footboard bracket screws, rider  | 36-42 ft-lbs  | 48.8-56.9 N-m | 3.43 RIDER FOOTRESTS, Install  |
| Footboard pivot screw nut, rider   | 60-80 in-lbs  | 6.8-9 N-m     | 3.43 RIDER FOOTRESTS, Assemble   |
| Footpeg pad screw: FLH, FLHT, FLHX, FLHXS, FLTRX, FLHRXS, FLHRXS                           | 15-20 ft-lbs  | 20.3-27.1 N-m | 3.44 PASSENGER FOOTRESTS, Assemble   |
| Footpeg pad screw: FLH, FLHT, FLHX, FLHXS,FLTRX,FLTRXS,FLHRXS                              | 15-20 ft-lbs  | 20.3-27.1 N-m | 3.44 PASSENGER FOOTRESTS, Install  |
| Fork bracket to fork pinch screws  | 14-18 ft-lbs  | 19-24.4 N-m   | 3.24 STEERING HEAD/FORK STEM AND BRACKET ASSEMBLY, Install                 |
| Fork bracket to fork pinch screws  | 14-18 ft-lbs  | 19-24.4 N-m   | 3.23 FRONT FORK, Install   |
| Fork bracket to fork pinch screws  | 14-18 ft-lbs  | 19-24.4 N-m   | 3.23 FRONT FORK, Install   |

| FASTENER                               | TORQUE VALUE   |               | NOTES   |
|--|----------------|---------------|---|
|  |                |               |   |
| Fork bracket to fork pinch screws      | 14-18 ft-lbs   | 19-24.4 N-m   | 3.23 FRONT FORK, Install  |
| Fork bracket to steer stem pinch screw | 22-26 ft-lbs   | 29.8-35.2 N-m | 3.24 STEERING HEAD/FORK STEM AND BRACKET ASSEMBLY, Install          |
| Fork mounted dash panel screw          | 25-30 in-lbs   | 2.8-3.4 N-m   | 3.30 FAIRING: FORK MOUNTED, Remove and Install: Dash Panel          |
| Fork mounted fairing screw             | 20-30 in-lbs   | 2.3-3.4 N-m   | 3.30 FAIRING: FORK MOUNTED, Remove and Install: Outer Fairing Shell |
| Fork mounted headlamp door screw       | 9-18 in-lbs    | 1-2 N-m       | 3.30 FAIRING: FORK MOUNTED, Remove and Install: Headlamp Assembly   |
| Fork mounted headlamp screw            | 22-32 in-lbs   | 2.5-3.6 N-m   | 3.30 FAIRING: FORK MOUNTED, Remove and Install: Headlamp Assembly   |
| Fork mounted inner fairing double stud | 120-180 in-lbs | 13.6-20.3 N-m | 3.30 FAIRING: FORK MOUNTED, Detach Fairing For Service              |
| Fork mounted inner fairing double stud | 120-180 in-lbs | 13.6-20.3 N-m | 3.30 FAIRING: FORK MOUNTED, Remove and Install: Inner Fairing Shell |
| Fork-mounted mirror flange nut         | 20-30 in-lbs   | 2.3-3.4 N-m   | 3.38 MIRRORS, Remove and Install: Fairing Mount                     |
| Fork mounted windshield screw          | 25-30 in-lbs   | 2.8-3.4 N-m   | 3.30 FAIRING: FORK MOUNTED, Remove and Install: Outer Fairing Shell |
| Fork slider assembly screw             | 30-37 ft-lbs   | 40-50 N-m     | 3.23 FRONT FORK, Assemble   |
| Fork slider cover screws               | 24-48 in-lbs   | 2.7-5.4 N-m   | 3.23 FRONT FORK, Install  |
| Front axle nut                         | 70-75 ft-lbs   | 95-102 N-m    | 3.4 FRONT WHEEL, Install  |
| Front axle pinch screw                 | 18-22 ft-lbs   | 24.5-30 N-m   | 3.4 FRONT WHEEL, Install  |
| Front brake caliper bleeder screw      | 62-89 in-lbs   | 7-10 N-m      | 3.20 BLEED BRAKES, Drain  |
| Front caliper banjo bolt               | 17-19 ft-lbs   | 23-26 N-m     | 3.14 FRONT BRAKE CALIPER, Complete                                  |
| Front caliper banjo bolt               | 17-19 ft-lbs   | 23.1-25.8 N-m | 3.18 BRAKE LINES, Brake Line: Front Caliper to ABS Module           |
| Front caliper mounting screw           | 28-38 ft-lbs   | 38-51.5 N-m   | 3.14 FRONT BRAKE CALIPER, Install                                   |
| Front Clamp Screw                      | 65 in-lbs      | 7.3 N-m       | 3.51 SADDLEBAG SUPPORTS, Install                                    |
| Front fender mounting screw            | 16-20 ft-lbs   | 21.7-27.1 N-m | 3.39 FRONT FENDER, Install  |
| Front fender tip screw                 | 20-25 in-lbs   | 2.3-2.8 N-m   | 3.39 FRONT FENDER, Assemble   |
| Front fender trim nut                  | 10-15 in-lbs   | 1.1-1.7 N-m   | 3.39 FRONT FENDER, Assemble   |
| Front fender trim skirt nut            | 10-15 in-lbs   | 1.1-1.7 N-m   | 3.39 FRONT FENDER, Assemble   |
| Front master cylinder banjo bolt       | 17-19 ft-lbs   | 23.1-25.8 N-m | 3.13 FRONT BRAKE MASTER CYLINDER, Install                           |
| Front master cylinder clamp screw      | 60-80 in-lbs   | 6.8-9 N-m     | 3.13 FRONT BRAKE MASTER CYLINDER, Install                           |
| Gauges, 2-inch diameter gauge screws   | 8-15 in-lbs    | 0.9-1.7 N-m   | 3.30 FAIRING: FORK MOUNTED, Remove and Install: Fairing             |
| Gauges, instrument cluster screws      | 10-20 in-lbs   | 1.1-2.3 N-m   | 3.30 FAIRING: FORK MOUNTED, Remove and Install: Fairing             |
| Glovebox screw                         | 60-84 in-lbs   | 6.8-9.5 N-m   | 3.30 FAIRING: FORK MOUNTED, Remove and Install: Glovebox            |
| Handlebar clamp shroud screw           | 10-20 in-lbs   | 1.1-2.3 N-m   | 3.29 HEADLAMP NACELLE, Install                                      |
| Handlebar upper clamp screws           | 16-20 ft-lbs   | 21.7-27.1 N-m | 3.37 HANDLEBAR, Remove and Install: Without Fairing                 |
| Handlebar upper clamp screws           | 16-20 ft-lbs   | 21.7-27.1 N-m | 3.37 HANDLEBAR, Remove and Install: Without Fairing                 |
| Handlebar upper clamp screws           | 16-20 ft-lbs   | 21.7-27.1 N-m | 3.37 HANDLEBAR, Remove and Install: Fork Mounted Fairing            |
| Handlebar upper clamp screws           | 16-20 ft-lbs   | 21.7-27.1 N-m | 3.37 HANDLEBAR, Remove and Install: Fork Mounted Fairing            |
| Handlebar upper clamp screws           | 16-20 ft-lbs   | 21.7-27.1 N-m | 3.37 HANDLEBAR, Remove and Install: Frame Mounted Fairing           |

| FASTENER   | TORQUE VALUE   |               | NOTES  |
|--|----------------|---------------|--|
| Handlebar upper clamp screws                         | 16-20 ft-lbs   | 21.7-27.1 N-m | 3.37 HANDLEBAR, Remove and Install: Frame Mounted Fairing                  |
| Handlebar upper clamp screws                         | 16-20 ft-lbs   | 21.7-27.1 N-m | 3.37 HANDLEBAR, Adjust   |
| Headlamp door screw                                  | 9-18 in-lbs    | 1-2 N-m       | 3.29 HEADLAMP NACELLE, Install   |
| Headlamp mount to nacelle screw                      | 9-18 in-lbs    | 1-2 N-m       | 3.29 HEADLAMP NACELLE, Install   |
| Headlamp nacelle acorn nut FLHR/C                    | 96-132 in-lbs  | 10.8-14.9 N-m | 3.29 HEADLAMP NACELLE, Install   |
| Headlamp nacelle chrome strip flange nut             | 15-20 in-lbs   | 1.7-2.3 N-m   | 3.29 HEADLAMP NACELLE, Install   |
| Headlamp nacelle stud/nut/grommet assembly FLHR/C    | 96-132 in-lbs  | 10.8-14.9 N-m | 3.29 HEADLAMP NACELLE, Install   |
| Hydraulic line multi-clamp screw                     | 10-15 in-lbs   | 1.1-1.7 N-m   | 3.18 BRAKE LINES, Brake Line: Rear Master Cylinder to ABS Module           |
| Inner fairing to mount screws: frame-mounted fairing | 96-144 in-lbs  | 10.9-16.3 N-m | 3.31 FAIRING: FRAME MOUNTED, Remove and Install: Radio Support Bracket     |
| Inner fairing-to-mount screws: Frame-mounted fairing | 96 in-lbs      | 10.9 N-m      | 3.31 FAIRING: FRAME MOUNTED, Remove and Install: Inner Fairing Shell       |
| Instrument bezel screws                              | 10-15 in-lbs   | 1.1-1.7 N-m   | 3.31 FAIRING: FRAME MOUNTED, Remove and Install: Instrument Bezel          |
| Instrument nacelle to fork bracket screws            | 96 in-lbs      | 10.8 N-m      | 3.31 FAIRING: FRAME MOUNTED, Remove and Install: Instrument Nacelle        |
| Jiffy stand bracket fasteners                        | 36-42 ft-lbs   | 48.8-57 N-m   | 3.45 JIFFY STAND, Install  |
| Jiffy stand leg stop hex screw                       | 15-20 ft-lbs   | 20.3-27.1 N-m | 3.45 JIFFY STAND, Install  |
| Lower air vent halves                                | 9-13 in-lbs    | 1-1.5 N-m     | 3.31 FAIRING: FRAME MOUNTED, Remove and Install: Lower Vents               |
| Lower air vent to inner fairing                      | 8-15 in-lbs    | 0.9-1.7 N-m   | 3.31 FAIRING: FRAME MOUNTED, Remove and Install: Lower Vents               |
| Lower fairing, lower clamp                           | 90-100 in-lbs  | 10.2-11.3 N-m | 3.32 FAIRING LOWERES, Remove and Install: Air-Cooled                       |
| Lower fairing, lower clamp                           | 90-100 in-lbs  | 10.2-11.3 N-m | 3.32 FAIRING LOWERES, Remove and Install: Twin-Cooled                      |
| Lower fairing, upper clamp nuts                      | 30-35 in-lbs   | 3.4-3.9 N-m   | 3.32 FAIRING LOWERES, Remove and Install: Air-Cooled                       |
| i Lower fairing, upper clamp nuts                    | 30-35 in-lbs   | 3.4-3.9 N-m   | 3.32 FAIRING LOWERES, Remove and Install: Twin-Cooled                      |
| Lower fairing cap flange nut                         | 30-35 in-lbs   | 3.4-3.9 N-m   | 3.32 FAIRING LOWERES, Remove and Install: Air-Cooled                       |
| Lower fairing cap flange nut                         | 30-35 in-lbs   | 3.4-3.9 N-m   | 3.32 FAIRING LOWERES, Remove and Install: Twin-Cooled                      |
| Lower fairing glove box screws                       | 12-17 in-lbs   | 1.4-1.9 N-m   | 3.32 FAIRING LOWERES, Disassemble and Assemble: Air-Cooled                 |
| Lower fairing glove box tray screws                  | 12-18 in-lbs   | 1.4-2 N-m     | 3.32 FAIRING LOWERES, Disassemble and Assemble: Air-Cooled                 |
| Lower fairing vent knob screw                        | 12-18 in-lbs   | 1.4-2 N-m     | 3.32 FAIRING LOWERES, Disassemble and Assemble: Air-Cooled                 |
| Lower screw (7)                                      | 48-72 in-lbs   | 5.4-8.1 N-m   | 3.44 PASSENGER FOOTRESTS, Install  |
| Lower vent to inner fairing: frame-mounted fairing   | 8-15 in-lbs    | 0.9-1.7 N-m   | 3.31 FAIRING: FRAME MOUNTED, Disassemble and Assemble: Inner Fairing Shell |
| Master cylinder banjo bolt                           | 17-19 ft-lbs   | 23.1-25.8 N-m | 3.18 BRAKE LINES, Brake Line: Front Master Cylinder to ABS Module          |
| Master cylinder screws                               | 126-150 in-lbs | 14.2-17 N-m   | 3.15 REAR BRAKE MASTER CYLINDER, Install                                   |
| Media compartment screw, lower                       | 8-12 in-lbs    | 0.9-1.3 N-m   | 3.30 FAIRING: FORK MOUNTED, Remove and Install: Fairing                    |

| FASTENER   | TORQUE VALUE   |               | NOTES   |
|--|----------------|---------------|---|
| Media compartment screw, lower   | 8-12 in-lbs    | 0.9-1.3 N-m   | 3.30 FAIRING: FORK MOUNTED, Remove and Install: Media Compartment               |
| Media compartment screw, upper   | 25-35 in-lbs   | 2.8-4 N-m     | 3.30 FAIRING: FORK MOUNTED, Remove and Install: Upper Support Bracket           |
| Mid-Frame deflector screw  | 25-35 in-lbs   | 2.8-4 N-m     | 3.34 AIR DEFLECTORS, Remove and Install: Mid Frame Deflectors                   |
| Mirror stem acorn nut  | 120-144 in-lbs | 13.6-16.3 N-m | 3.38 MIRRORS, Remove and Install: Handlebar Mount                               |
| Muffler to saddlebag support screws                                    | 14-18 ft-lbs   | 19-24.4 N-m   | 3.51 SADDLEBAG SUPPORTS, Complete   |
| Outer fairing lower screws (also air deflector): frame mounted fairing | 8-15 in-lbs    | 0.9-1.7 N-m   | 3.31 FAIRING: FRAME MOUNTED, Remove and Install: Outer Fairing Shell            |
| Outer fairing screws: Fork-mounted fairing models                      | 20-30 in-lbs   | 2.3-3.4 N-m   | 3.30 FAIRING: FORK MOUNTED, Remove and Install: Windshield                      |
| Outer fairing upper screws (near speakers): frame mounted fairing      | 20-30 in-lbs   | 2.3-3.4 N-m   | 3.31 FAIRING: FRAME MOUNTED, Remove and Install: Outer Fairing Shell            |
| Parking brake nut  | 10-14 ft-lbs   | 14-19 N-m     | 3.17 PARKING BRAKE ASSEMBLY, Install  |
| Passenger backrest flange nuts.  | 108-132 in-lbs | 12.2-14.9 N-m | 3.48 TOUR-PAK, Install  |
| Passenger backrest flap screws   | 21-24 in-lbs   | 2.4-2.7 N-m   | 3.48 TOUR-PAK, Install  |
| Power outlet, front  | 13-17 in-lbs   | 1.5-1.9 N-m   | 3.30 FAIRING: FORK MOUNTED, Remove and Install: Fairing                         |
| Radio support bracket to inner fairing screws: frame-mounted fairing   | 48-60 in-lbs   | 5.4-6.8 N-m   | 3.31 FAIRING: FRAME MOUNTED, Disassemble and Assemble: Inner Fairing Shell      |
| Radio support bracket to inner fairing screws: frame-mounted fairing   | 48-60 in-lbs   | 5.4-6.8 N-m   | 3.31 FAIRING: FRAME MOUNTED, Disassemble and Assemble: Inner Fairing Shell      |
| Radio support bracket to inner fairing screws: frame-mounted fairing   | 48-60 in-lbs   | 5.4-6.8 N-m   | 3.31 FAIRING: FRAME MOUNTED, Remove and Install: Radio Support Bracket          |
| Rear axle cone nut, 1st torque   | 15-20 ft-lbs   | 20-27 N-m     | 3.5 REAR WHEEL, Install<br>Final torque completed during drive belt adjustment. |
| Rear battery tray screw  | 132-156 in-lbs | 14.9-17.6 N-m | 3.18 BRAKE LINES, Brake Line: Front Master Cylinder to ABS Module               |
| Rear battery tray screw  | 132-156 in-lbs | 14.9-17.6 N-m | 3.18 BRAKE LINES, Brake Line: Front Caliper to ABS Module                       |
| Rear brake caliper bleeder screw                                       | 106-142 in-lbs | 12-16 N-m     | 3.20 BLEED BRAKES, Drain  |
| Rear caliper banjo bolt  | 17-19 ft-lbs   | 23.1-25.8 N-m | 3.16 REAR BRAKE CALIPER, Complete   |
| Rear caliper mounting screw  | 43-48 ft-lbs   | 58.3-65.1 N-m | 3.16 REAR BRAKE CALIPER, Install  |
| Rear fender mounting nut   | 15-20 ft-lbs   | 20.3-27.1 N-m | 3.40 REAR FENDER, Assemble  |
| Rear fender mounting screw   | 15-20 ft-lbs   | 20.3-27 N-m   | 3.40 REAR FENDER, Install   |
| Rear fender stud plate nut   | 60-96 in-lbs   | 6.8-10.8 N-m  | 3.40 REAR FENDER, Assemble  |
| Rear fork bracket screws   | 55-65 ft-lbs   | 74.6-88.1 N-m | 3.25 REAR FORK, Install   |
| Rear fork pivot shaft screws   | 55-65 ft-lbs   | 74.6-88.1 N-m | 3.25 REAR FORK, Install   |
| Rear frame to main frame fastener                                      | 40-45 ft-lbs   | 54.2-61 N-m   | 3.47 REAR FRAME, Install  |
| Rear Inboard Screw   | 15-20 ft-lbs   | 20.3-27.1 N-m | 3.51 SADDLEBAG SUPPORTS, Install  |
| Rear master cylinder banjo bolt  | 17-19 ft-lbs   | 23-25.8 N-m   | 3.15 REAR BRAKE MASTER CYLINDER, Install  |
| Rear Outboard Screw  | 30-37 ft-lbs   | 40.7-50.2 N-m | 3.51 SADDLEBAG SUPPORTS, Install  |
| Rear rotor screw   | 30-45 ft-lbs   | 41-61 N-m     | 3.5 REAR WHEEL, Assemble  |
| Rear shock absorber mounting bolt                                      | 63-70 ft-lbs   | 85.4-95 N-m   | 3.27 REAR SHOCK ABSORBERS, Install  |
| Saddlebag face plate/hinge screw                                       | 40-45 in-lbs   | 4.5-5.1 N-m   | 3.50 SADDLEBAGS, Assemble   |
| Saddlebag face plate/hinge screws                                      | 40-45 in-lbs   | 4.5-5.1 N-m   | 3.50 SADDLEBAGS, Assemble   |
| Saddlebag face plate/hinge screws                                      | 40-45 in-lbs   | 4.5-5.1 N-m   | 3.50 SADDLEBAGS, Assemble   |
| Saddlebag guard to frame screw, lower                                  | 32-36 ft-lbs   | 43.4-48.8 N-m | 3.51 SADDLEBAG SUPPORTS, Install  |
| Saddlebag guard to frame screw, upper                                  | 32-36 ft-lbs   | 43.4-48.8 N-m | 3.51 SADDLEBAG SUPPORTS, Install  |

| FASTENER  | TORQUE VALUE      |               | NOTES   |
|---|-------------------|---------------|---|
| Saddlebag hinge to latch assembly screws                    | 30-35 in-lbs      | 3.4-3.9 N-m   | 3.50 SADDLEBAGS, Assemble   |
| Saddlebag hinge to saddlebag screws                         | 40-45 in-lbs      | 4.5-5.1 N-m   | 3.50 SADDLEBAGS, Assemble   |
| Saddlebag latch assembly screws                             | 40-45 in-lbs      | 4.5-5.1 N-m   | 3.50 SADDLEBAGS, Assemble   |
| Saddlebag latch handle screw                                | 40-45 in-lbs      | 4.5-5.1 N-m   | 3.50 SADDLEBAGS, Assemble   |
| Saddlebag lock lever nut                                    | 25-35 in-lbs      | 2.8-3.9 N-m   | 3.50 SADDLEBAGS, Assemble   |
| Saddlebag lock lever nut                                    | 25-35 in-lbs      | 2.8-3.9 N-m   | 3.50 SADDLEBAGS, Assemble   |
| Saddlebag lock lever nut                                    | 25-35 in-lbs      | 2.8-3.9 N-m   | 3.50 SADDLEBAGS, Assemble   |
| Saddlebag lock screw  | 20-30 in-lbs      | 2.3-3.4 N-m   | 3.50 SADDLEBAGS, Assemble   |
| Saddlebag strike screw                                      | 15-20 in-lbs      | 1.7-2.3 N-m   | 3.50 SADDLEBAGS, Assemble   |
| Saddlebag support casting to frame screw                    | 15-20 ft-lbs      | 20.3-27.1 N-m | 3.51 SADDLEBAG SUPPORTS, Install  |
| Saddlebag support tube screw                                | 70-100 in-lbs     | 7.9-11.3 N-m  | 3.51 SADDLEBAG SUPPORTS, Install  |
| Saddlebag support tube to support casting fastener, large   | 30-37 ft-lbs      | 40.7-50.2 N-m | 3.51 SADDLEBAG SUPPORTS, Install  |
| Saddlebag support tube to support casting fastener, small   | 15-20 ft-lbs      | 20.3-27.1 N-m | 3.51 SADDLEBAG SUPPORTS, Install  |
| Saddlebag tether screws                                     | 40-45 in-lbs      | 4.5-5.1 N-m   | 3.50 SADDLEBAGS, Assemble   |
| Saddlebag tether screws                                     | 40-45 in-lbs      | 4.5-5.1 N-m   | 3.50 SADDLEBAGS, Assemble   |
| Seat bracket assembly acorn nut                             | 48-84 in-lbs      | 5.4-9.5 N-m   | 3.46 SEAT, Install  |
| Seat bracket mount screws                                   | 15-20 ft-lbs      | 20.3-27.1 N-m | 3.46 SEAT, Install  |
| Seat bracket-to-bumper nuts                                 | 2,655-3,275 inlbs | 300-370 N-m   | 3.46 SEAT, Install  |
| Seat bumper fastener: FLHX, FLHXS and FLTRX, FLTRXS, FLHRXS | 32-36 ft-lbs      | 43.4-48.8 N-m | 3.46 SEAT, Install  |
| Seat fairing flange nuts                                    | 60-96 in-lbs      | 6.8-10.8 N-m  | 3.46 SEAT, Install  |
| Seat mounting screw   | 48-72 in-lbs      | 5.4-8.1 N-m   | 3.46 SEAT, Install  |
| Seat spring lower screws                                    | 36-60 in-lbs      | 4.1-6.8 N-m   | 3.46 SEAT, Install  |
| Seat strap bracket screw                                    | 120-144 in-lbs    | 13.6-16.3 N-m | 3.51 SADDLEBAG SUPPORTS, Install  |
| Seat strap screw  | 48-72 in-lbs      | 5.4-8.1 N-m   | 3.46 SEAT, Install  |
| Seat suspension acorn nuts                                  | 60-96 in-lbs      | 6.8-10.8 N-m  | 3.46 SEAT, Install  |
| Seat-to-bracket flange nuts                                 | 850-1,274 in-lbs  | 96-144 N-m    | 3.46 SEAT, Install  |
| Seat-to-bracket hex screw                                   | 60-120 in-lbs     | 6.8-13.6 N-m  | 3.46 SEAT, Install  |
| Shock absorber mounting bolt                                | 63-70 ft-lbs      | 85.4-95 N-m   | 3.25 REAR FORK, Complete  |
| Speedometer bracket acorn nuts: FLHP                        | 72-108 in-lbs     | 8.1-12.2 N-m  | 3.29 HEADLAMP NACELLE, Complete   |
| Storage compartment door hinge screws                       | 8-15 in-lbs       | 0.9-1.7 N-m   | 3.31 FAIRING: FRAME MOUNTED, Remove and Install: Storage Compartment Doors and Hinges |
| Storage compartment door screws                             | 8-15 in-lbs       | 0.9-1.7 N-m   | 3.31 FAIRING: FRAME MOUNTED, Remove and Install: Storage Compartment Doors and Hinges |
| Storage compartment door screws                             | 8-15 in-lbs       | 0.9-1.7 N-m   | 3.31 FAIRING: FRAME MOUNTED, Remove and Install: Storage Compartment Doors and Hinges |
| Storage compartment screws                                  | 48-60 in-lbs      | 5.4-6.8 N-m   | 3.31 FAIRING: FRAME MOUNTED, Disassemble and Assemble: Inner Fairing Shell            |
| Storage compartment screws                                  | 48-60 in-lbs      | 5.4-6.8 N-m   | 3.31 FAIRING: FRAME MOUNTED, Remove and Install: Storage Compartments                 |
| Top vent door mechanism screws                              | 6-8 in-lbs        | 0.7-0.9 N-m   | 3.31 FAIRING: FRAME MOUNTED, Remove and Install: Upper Vent                           |
| Tour-Pak adapter mounting screws                            | 60-72 in-lbs      | 6.8-8.1 N-m   | 3.48 TOUR-PAK, Install  |
| Tour-Pak catch screws                                       | 25-35 in-lbs      | 2.8-3.9 N-m   | 3.48 TOUR-PAK, Disassemble and Assemble   |
| Tour-Pak hinge screw  | 25-35 in-lbs      | 2.8-3.9 N-m   | 3.48 TOUR-PAK, Disassemble and Assemble   |



| FASTENER  | TORQUE VALUE   |               | NOTES   |
|---|----------------|---------------|---|
| Tour-Pak latch handle screws                                    | 25-35 in-lbs   | 2.8-3.9 N-m   | 3.48 TOUR-PAK, Disassemble and Assemble                               |
| Tour-Pak lockset screws   | 25-35 in-lbs   | 2.8-3.9 N-m   | 3.48 TOUR-PAK, Disassemble and Assemble                               |
| Tour-Pak luggage rack fastener                                  | 40-48 in-lbs   | 4.5-5.4 N-m   | 3.48 TOUR-PAK, Disassemble and Assemble                               |
| Tour-Pak mounting nuts  | 60-72 in-lbs   | 6.8-8.1 N-m   | 3.48 TOUR-PAK, Install  |
| Tour-Pak mounting nuts  | 60-72 in-lbs   | 6.8-8.1 N-m   | 3.48 TOUR-PAK, Install  |
| Tour-Pak mounting nuts  | 60-72 in-lbs   | 6.8-8.1 N-m   | 3.48 TOUR-PAK, Disassemble and Assemble                               |
| Tour-Pak side marker lamp screws                                | 20-25 in-lbs   | 2.3-2.8 N-m   | 3.48 TOUR-PAK, Disassemble and Assemble                               |
| Tour-Pak support cover screws                                   | 8-18 in-lbs    | 0.9-2 N-m     | 3.49 TOUR-PAK SUPPORT, Assemble                                       |
| Tour-Pak support screws   | 15-20 ft-lbs   | 20.3-27.1 N-m | 3.49 TOUR-PAK SUPPORT, Install  |
| Tour-Pak tether anchor screws                                   | 16-22 in-lbs   | 1.8-2.5 N-m   | 3.48 TOUR-PAK, Disassemble and Assemble                               |
| Tour-Pak tether anchor screws                                   | 16-22 in-lbs   | 1.8-2.5 N-m   | 3.48 TOUR-PAK, Disassemble and Assemble                               |
| Tour-Pak tether reel screws                                     | 16-22 in-lbs   | 1.8-2.5 N-m   | 3.48 TOUR-PAK, Disassemble and Assemble                               |
| Turn signal lamp mounting screw, front: frame mounted fairing   | 48-60 in-lbs   | 5.4-6.8 N-m   | 3.31 FAIRING: FRAME MOUNTED, Remove and Install: Outer Fairing Shell  |
| Upper screw (2)   | 36-42 ft-lbs   | 48.8-56.9 N-m | 3.44 PASSENGER FOOTRESTS, Install                                     |
| Upper steering stem, 1st torque                                 | 35 ft-lbs      | 47.5 N-m      | 3.24 STEERING HEAD/FORK STEM AND BRACKET ASSEMBLY, Install            |
| Upper steering stem, final torque: Fork mounted fairing models  | 63 in-lbs      | 7.1 N-m       | 3.24 STEERING HEAD/FORK STEM AND BRACKET ASSEMBLY, Install            |
| Upper steering stem, final torque: Frame mounted fairing models | 192 in-lbs     | 21.7 N-m      | 3.24 STEERING HEAD/FORK STEM AND BRACKET ASSEMBLY, Install            |
| Upper steering stem, final torque: Road King models             | 108 in-lbs     | 12.2 N-m      | 3.24 STEERING HEAD/FORK STEM AND BRACKET ASSEMBLY, Install            |
| Upper steering stem, final torque: Trike models                 | 108 in-lbs     | 12.2 N-m      | 3.24 STEERING HEAD/FORK STEM AND BRACKET ASSEMBLY, Install            |
| Upper support bracket to glovebox screw                         | 2.0-3.0 ft-lbs | 2.7-4 N-m     | 3.30 FAIRING: FORK MOUNTED, Remove and Install: Glovebox              |
| Upper support bracket to inner fairing screw                    | 0.8-1.6 ft-lbs | 1.1-2.2 N-m   | 3.30 FAIRING: FORK MOUNTED, Remove and Install: Glovebox              |
| Upper support bracket to inner fairing screws                   | 10-19 in-lbs   | 1.1-2.2 N-m   | 3.30 FAIRING: FORK MOUNTED, Remove and Install: Fairing               |
| Upper support bracket to inner fairing screws                   | 10-19 in-lbs   | 1.1-2.2 N-m   | 3.30 FAIRING: FORK MOUNTED, Remove and Install: Upper Support Bracket |
| Upper support bracket to radio (storage box) screws             | 25-35 in-lbs   | 2.8-4 N-m     | 3.30 FAIRING: FORK MOUNTED, Remove and Install: Upper Support Bracket |
| Upper support bracket to speaker enclosure screw                | 4.0-5.0 ft-lbs | 5.4-6.8 N-m   | 3.30 FAIRING: FORK MOUNTED, Remove and Install: Glovebox              |
| Upper support bracket to speaker enclosure screws               | 48-60 in-lbs   | 5.4-6.8 N-m   | 3.30 FAIRING: FORK MOUNTED, Remove and Install: Upper Support Bracket |
| Valve stem  | 23-27 in-lbs   | 2.6-3 N-m     | 3.10 TIRE PRESSURE MONITORING SYSTEM (TPMS), Install                  |
| Valve stem nut  | 12-15 in-lbs   | 1.4-1.7 N-m   | 3.11 TIRES, Install   |
| Vent assembly to inner fairing screw                            | 20-30 in-lbs   | 2.3-3.4 N-m   | 3.30 FAIRING: FORK MOUNTED, Disassemble and Assemble: Vent            |
| Windshield screws: Fork-mounted fairing models                  | 25-30 in-lbs   | 2.8-3.4 N-m   | 3.30 FAIRING: FORK MOUNTED, Remove and Install: Windshield            |
| Windshield screws: frame mounted fairing                        | 8-12 in-lbs    | 0.9-1.4 N-m   | 3.31 FAIRING: FRAME MOUNTED, Remove and Install: Outer Fairing Shell  |
| Windshield screws: Frame mounted fairing models                 | 8-12 in-lbs    | 0.9-1.4 N-m   | 3.31 FAIRING: FRAME MOUNTED, Remove and Install: Windshield           |
| Windshield window screw Road King models                        | 20-25 in-lbs   | 2.3-2.8 N-m   | 3.35 WINDSHIELD, Assemble   |

**Chassis Specifications**

**Table 3-1. Dimensions: Revival (FLH), Electra Glide Standard (FLHT), Electra Glide Ultra Limited (FLHTK), Road Glide Limited (FLTRK)**

| ITEM                      | Revival™ (FLH) |      | Electra Glide® Standard (FLHT) |      | Electra Glide® Ultra Limited (FLHTK) |      | Road Glide® Limited (FLTRK) |      |
|---------------------------|----------------|------|--------------------------------|------|--------------------------------------|------|-----------------------------|------|
|                           | in             | mm   | in                             | mm   | in                                   | mm   | in                          | mm   |
| Length                    | 95.5           | 2425 | 94.5                           | 2400 | 102.3                                | 2600 | 102.2                       | 2595 |
| Overall Width             | 37.8           | 960  | 38.0                           | 965  | 37.8                                 | 960  | 36.6                        | 930  |
| Overall height            | 57.0           | 1441 | 55.3                           | 1405 | 56.7                                 | 1440 | 56.1                        | 1425 |
| Wheel base                | 64.0           | 1625 | 64.0                           | 1625 | 64.0                                 | 1625 | 64.0                        | 1625 |
| Road clearance            | 4.9            | 125  | 4.7                            | 120  | 5.3                                  | 135  | 5.1                         | 130  |
| Seat height <sup>1*</sup> | 29.6           | 752  | 26.1                           | 663  | 27.5                                 | 699  | 27.2                        | 690  |

(1) With 180 lb (81.7 kg) rider on seat

**Table 3-2. Dimensions: Road King (FLHR), Road King Special (FLHRXS), Street Glide (FLHX), Street Glide Special (FLHXS), Road Glide (FLTRX), Road Glide Special (FLTRXS)**

| ITEM                        | Road King® (FLHR) |            | Road King® Special (FLHRXS) |      | Street Glide® (FLHX) |      | Street Glide® Special (FLHXS) |      | Road Glide® (FLTRX) |      | Road Glide® Special (FLTRXS) |      |
|-----------------------------|-------------------|------------|-----------------------------|------|----------------------|------|-------------------------------|------|---------------------|------|------------------------------|------|
|                             | in                | mm         | in                          | mm   | in                   | mm   | in                            | mm   | in                  | in   | mm                           | mm   |
| 95.5                        | 2425              | Length     | 96.5                        | 2450 | 95.3                 | 2420 | 96.5                          | 2450 | 95.7                | 95.7 | 2430                         | 2430 |
| Overall width               | 37.8              | 960        | 39.0                        | 990  | 37.8                 | 960  | 37.8                          | 960  | 38.6                | 980  | 39.0                         | 990  |
| Overall height              | 56.3              | 1430       | 45.3                        | 1150 | 53.1                 | 1350 | 52.6                          | 1335 | 51.6                | 1310 | 52.2                         | 1325 |
| 64.0                        | 1625              | Wheel base | 64.0                        | 1625 | 64.0                 | 1625 | 64.0                          | 1625 | 64.0                | 64.0 | 1625                         | 1625 |
| Road clearance              | 5.3               | 135        | 4.9                         | 125  | 5.3                  | 135  | 4.9                           | 125  | 5.5                 | 140  | 5.1                          | 130  |
| Saddle height <sup>1*</sup> | 26.3              | 667        | 26.4                        | 671  | 26.1                 | 664  | 26.1                          | 664  | 25.9                | 658  | 25.9                         | 658  |

(1) With 180 lb (81.7 kg) rider on seat

**Table 3-3. Weights: Revival (FLH), Electra Glide Standard (FLHT), Electra Glide Ultra Limited (FLHTK), Road Glide Limited (FLTRK)**

| ITEM  | Revival™ (FLH) |     | Electra Glide® Standard (FLHT) |     | Electra Glide® Ultra Limited (FLHTK) |     | Road Glide® Limited (FLTRK) |     |
|---|----------------|-----|--------------------------------|-----|--------------------------------------|-----|-----------------------------|-----|
|   | lb             | kg  | lb                             | kg  | lb                                   | kg  | lb                          | kg  |
| Running weight <sup>1</sup>                 | 856            | 388 | 820                            | 372 | 917                                  | 416 | 932                         | 423 |
| Maximum added weight allowed <sup>121</sup> | 504            | 229 | 540                            | 245 | 443                                  | 201 | 428                         | 194 |
| GVWR  | 1360           | 617 | 1360                           | 617 | 1360                                 | 617 | 1360                        | 617 |
| GAWR front                                  | 500            | 227 | 500                            | 227 | 500                                  | 227 | 500                         | 227 |
| GAWR rear                                   | 927            | 420 | 927                            | 420 | 927                                  | 420 | 927                         | 420 |

(1) The total weight of the motorcycle as delivered with all oil/fluids and approximately 90% of fuel.

(2) The total weight of accessories, cargo, riding gear, passenger and rider must not exceed this weight.

**Table 3-4. Weights: Road King (FLHR), Road King Special (FLHRXS), Street Glide (FLHX), Street Glide Special (FLHXS), Road Glide (FLTRX), Road Glide Special (FLTRXS)**

| ITEM  | Road King® (FLHR) |     | Road King® Special (FLHRXS) |     | Street Glide® (FLHX) |     | Street Glide® Special (FLHXS) |     | Road Glide® (FLTRX) |     | Road Glide® Special (FLTRXS) |     |
|---|-------------------|-----|-----------------------------|-----|----------------------|-----|-------------------------------|-----|---------------------|-----|------------------------------|-----|
|   | lb                | kg  | lb                          | kg  | lb                   | kg  | lb                            | kg  | lb                  | lb  | kg                           | kg  |
| Running weight <sup>1*</sup>                | 828               | 375 | 807                         | 366 | 829                  | 376 | 827                           | 375 | 855                 | 388 | 853                          | 387 |
| Maximum added weight allowed <sup>121</sup> | 532               | 247 | 553                         | 251 | 531                  | 242 | 533                           | 242 | 505                 | 229 | 507                          | 230 |
| GVWR  | 1360              | 617 | 1360                        | 617 | 1360                 | 617 | 1360                          | 617 | 1360                | 617 | 1360                         | 617 |

**Table 3-4. Weights: Road King (FLHR), Road King Special (FLHRXS), Street Glide (FLHX), Street Glide Special (FLHXS), Road Glide (FLTRX), Road Glide Special (FLTRXS)**

| ITEM       | Road King® (FLHR) |     | Road King® Special (FLHRXS) |     | Street Glide® (FLHX) |     | Street Glide® Special (FLHXS) |     | Road Glide® (FLTRX) |     | Road Glide® Special (FLTRXS) |     |
|------------|-------------------|-----|-----------------------------|-----|----------------------|-----|-------------------------------|-----|---------------------|-----|------------------------------|-----|
|            | lb                | kg  | lb                          | kg  | lb                   | kg  | lb                            | kg  | lb                  | kg  | lb                           | kg  |
| GAWR front | 500               | 227 | 500                         | 227 | 500                  | 227 | 500                           | 227 | 500                 | 227 | 500                          | 227 |
| GAWR rear  | 927               | 420 | 927                         | 420 | 927                  | 420 | 927                           | 420 | 927                 | 420 | 927                          | 420 |

(1) The total weight of the motorcycle as delivered with all oil/fluids and approximately 90% of fuel.

(2) The total weight of accessories, cargo, riding gear) passenger and rider must not exceed this weight.

**A WARNING**

**Do not exceed the motorcycle's Gross Vehicle Weight Rating (GVWR) or Gross Axle Weight Rating (GAWR). Exceeding these weight ratings can lead to component failure and adversely affect stability, handling and performance, which could result in death or serious injury. (00016f)**

<sup>1</sup> GVWR is the sum of the weight of the motorcycle, accessories and the maximum weight of the rider, passenger and cargo that can be safely carried.

- GAWR is the maximum amount of weight that can be safely carried on each axle.
- The GVWR and GAWR are shown on the information plate, on the frame downtube.

**NOTE**

- The maximum additional weight allowed on the motorcycle equals the Gross Vehicle Weight Rating (GVWR) minus the running weight. For example, a motorcycle with GVWR of 1,199.30 lb (544 kg) having a running weight of 800.27 lb (363 kg), would allow a maximum of an additional 399.03 lb (181 kg) combined weight of the rider, passenger, riding gear, cargo and installed accessories.

- For important information regarding tire data and tire inflation, see *INSPECT TIRES AND WHEELS* (Page 2-15).

**Tire Specifications**

**A WARNING**

**Harley-Davidson recommends the use of its specified tires. Harley-Davidson vehicles are not designed for operation with non-specified tires, including snow, moped and other special-use tires. Use of non-specified tires can adversely affect stability, handling or braking and lead to loss of vehicle control, which could result in death or serious injury. (00024d)**

**NOTE**

ABS equipped motorcycles must always use tires and wheels that are the same as the original equipment. ABS monitors rotational speed of the wheels through individual wheel speed sensors to determine the application of ABS. Changing to different diameter wheels or different size tires can alter the rotational speed. This will upset the system calibration and have an adverse effect on its ability to detect and prevent lockups. Operating with inflation pressure other than those specified can reduce ABS performance.

# VEHICLE IDENTIFICATION NUMBER (VIN) VEHICLE IDENTIFICATION NUMBER (VIN)

## General

See Figure 3-2. A unique 17-digit serial or Vehicle Identification Number (VIN) is assigned to each motorcycle. Refer to Table 3-5.

## Location

See Figure 3-1. The full 17-digit VIN is stamped on the right side of the frame near the steering head. In some destinations, a printed VIN label is also attached on the front downtube.

## Abbreviated VIN

An abbreviated VIN showing the vehicle model, engine type, model year, and sequential number is stamped on the left side of the crankcase between the engine cylinders.

### NOTE

Always give the full 17-digit Vehicle Identification Number when ordering parts or making any inquiry about your motorcycle.

1445558

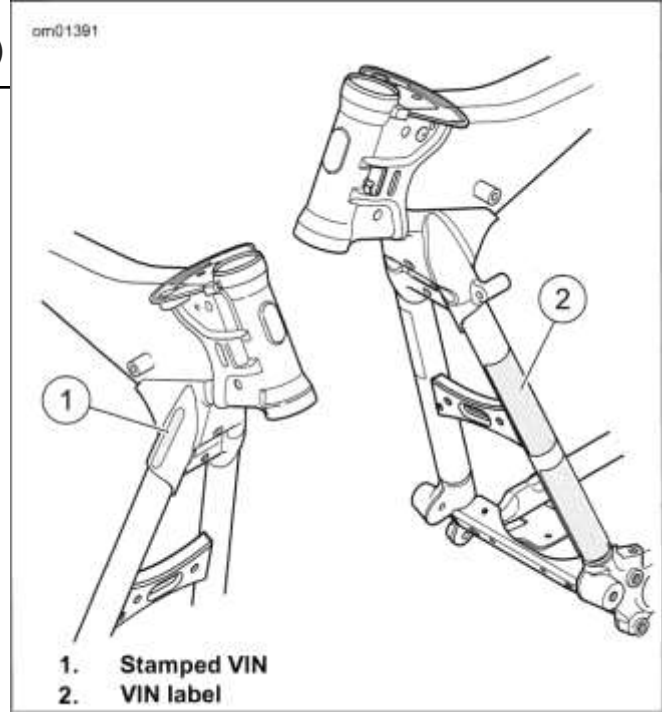


Figure 3-1. VIN Locations

# 1 HD 1 KE F 1 9MB 600041

Figure 3-2. Typical Harley-Davidson VIN: 2021 Harley-Davidson Touring Models

Table 3-5. Harley-Davidson VIN Breakdown: 2021 Touring Models

| POSITION | DESCRIPTION                   | POSSIBLE VALUES  |
|----------|-------------------------------|--|
| 1        | World manufacturer identifier | 1HD=Originally manufactured in the United States<br>5HD=Originally manufactured in the United States for sale outside of the United States<br>932=Originally manufactured in Brazil<br>MEG=Originally manufactured in India<br>MLY=Originally manufactured in Thailand |
| 2        | Motorcycle type               | 1=Heavyweight motorcycle (901 cm or larger)  |
| 3        | Model                         | See VIN model table  |
| 4        | Engine type                   | C=Milwaukee-Eight 107 Engine, 1745 cm <sup>3</sup><br>F=Twin-Cooled™ Milwaukee-Eight 114 Engine, 1868 cm <sup>3</sup><br>P=Milwaukee-Eight 114 Engine, 1868 cm <sup>3</sup>  |

**Table 3-5. Harley-Davidson VIN Breakdown: 2021 Touring Models**

| POSITION | DESCRIPTION                             | POSSIBLE VALUES   |
|----------|---|---|
| 5        | Calibration/configuration, introduction | 1=Domestic (DOM)<br>2=California (CAL)<br>3=Canada (CAN)<br>4=ENG/EN2/HDI/HD2/HD4<br>5=Japan (JPN)<br>6=Australia (AUS)<br>7=Brazil (BRZ)<br>8=Asia Pacific (APC)<br>9=IND/IN2<br>0=ASEAN (AZN)<br>A=China (CHN)<br>G=HD3 |
| 6        | VIN check digit                         | Can be 0-9 or X   |
| 7        | Model year                              | M=2021  |
| 8        | Assembly plant                          | B=York, PA U.S.A.<br>D=H-D Brazil-Manaus, Brazil (CKD)<br>N=Haryana India (Bawal District Rewari)<br>S=Tasit, Pluagdang, Rayong, Thailand   |
| 9        | Sequential number                       | Varies  |

**Table 3-6. VIN Model Codes: Touring Models**

| CODE | MODEL                                | CODE | MODEL  |
|------|--------------------------------------|------|--|
| AA   | Revival™ (FLH)                       | KN   | Electra Glide® Ultra Limited Shrine (FLHTK-SHRINE) |
| FB   | Road King® (FLHR)                    | KR   | Street Glide® Special (FLHXS)                      |
| FV   | Electra Glide® Standard (FLHT)       | KT   | Road Glide® Special (FLTRXS)                       |
| KB   | Street Glide® (FLHX)                 | KV   | Road King® Special (FLHRXS)                        |
| KE   | Electra Glide® Ultra Limited (FLHTK) | KZ   | Road Glide® Limited (FLTRK)                        |
| KH   | Road Glide® (FLTRX)                  |      |  |

**PREPARE**

**NOTICE**

When lifting a motorcycle using a jack, be sure jack contacts both lower frame tubes where down tubes and lower frame tubes converge. Never lift by jacking on cross-members, oil pan, mounting brackets, components or housings. Failure to comply can cause serious damage resulting in the need to perform major repair work. (00586d)

1. Raise front wheel. See Secure the Motorcycle for Service (Page 2-3).
2. Check wheel bearings. See SEALED WHEEL BEARINGS (Page 3-26).
3. Measure brake disc runout. See INSPECT BRAKES (Page 2-19).
4. Detach front brake calipers from fork. Support calipers. See FRONT BRAKE CALIPER (Page 3-40).

**REMOVE**

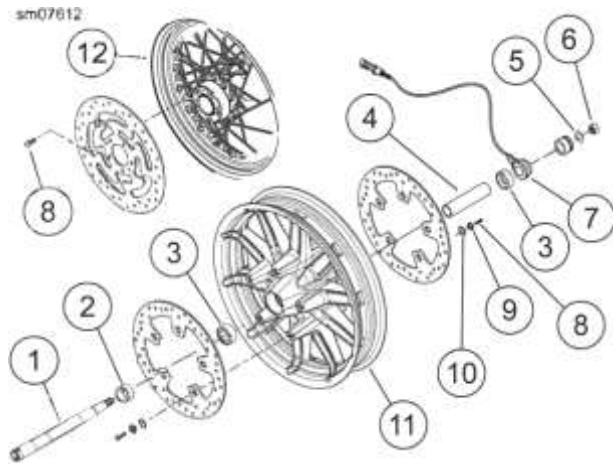
*NOTE*

Do not operate the front brake hand lever with the calipers removed or the pistons may be forced out. The caliper contains no serviceable components and would require replacement.

1. See Figure 3-3. Remove wheel.
  - a. Remove axle nut (6) and flat washer (5).
  - b. Loosen axle pinch screw at bottom of right side fork slider.
  - c. Remove axle (1), outer spacer(s) (2) and front Wheel Speed Sensor (WSS) (7) (if ABS equipped).

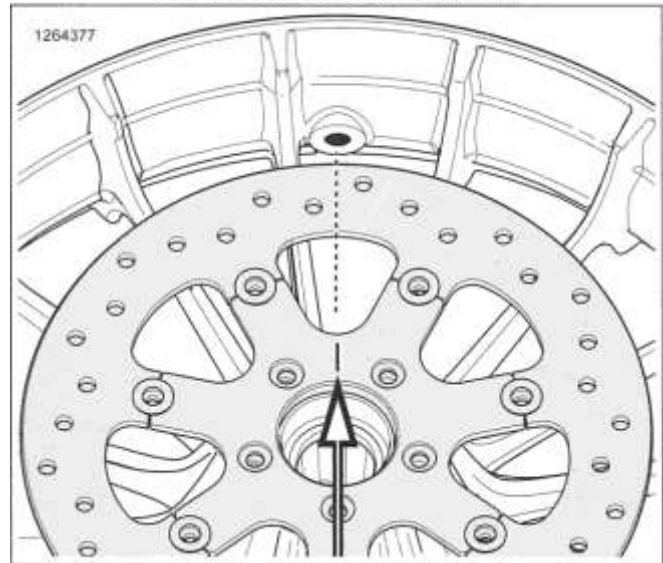
*NOTE*

- Never pull WSS cable taut or use to retain wheel, axle or other components.
- Always keep the WSS and ABS encoder bearing away from magnetic fields. Items such as magnetic parts trays, magnetic base dial indicators, alternator rotors will damage sensor.



1. Axle
2. Outer spacer
3. Bearing (2)
4. Inner spacer
5. Flat washer
6. Nut
7. WSS
8. Screw, brake disc
9. Bushing (cast wheels)
10. Spring washer (cast wheels)
11. Cast wheel (typical)
12. Laced wheel

**Figure 3-3. Front Wheel (typical)**



**Figure 3-4. Floating Brake Disc Alignment**  
**INSTALL**

| FASTENER               | TORQUE VALUE         |              |
|------------------------|----------------------|--------------|
| Front axle nut         | 70-75 ft-lbs         | 95-102 N-m   |
| Front axle pinch screw | 18-22 ft-lbs         | 24.5-30 N -m |
| PART NUMBER            | CONSUMABLE           |              |
| 98960-97               | ANTI-SEIZE LUBRICANT |              |

*NOTE*

- See *Figure 3-3*. Install outer spacers (2) with grooves on the outboard side.

# FRONT WHEEL

ABS models: Install WSS (7) with index pin on outboard side.

• Left and right spacers are interchangeable on non-ABS models.

1. Install front wheel.
  - a. See Figure 3-3. Apply light coat of anti-seize to axle (1), bearing bores and bore of spacer (4).  
  
ANTI-SEIZE LUBRICANT (98960-97)
  - b. Place wheel into position with valve stem on right side.
  - c. Install axle through right fork, outer spacer, wheel hub, front WSS (ABS models) or second outer spacer, and left fork.
  - d. Install flat washer (5) and axle nut (6).
  - e. ABS models: Rotate WSS until it contacts rear of fork slider. Back off enough to maintain clearance between WSS wire stem and fork slider.

2. Tighten axle nut.  
  
Torque: 70-75 ft-lbs (95-102 N-m) *Front axle nut*

3. **NOTE**  
 ABS models: Verify that WSS cable is installed in bracket and that retainer is secure. Retainer cannot be installed once mounting screws are started.

Push and hold right fork slider inboard until it contacts external spacer. Tighten axle pinch screw.

Torque: 18-22 ft-lbs (24.5-30 N-m) *Front axle pinch screw*

## DISASSEMBLE

1. See Figure 3-3. Remove front brake disc.
  - a. Remove and discard screws (8).
  - b. Cast wheels: Remove bushings (9) and spring washers (10).
  - c. Remove front brake disc.
2. Remove front tire. See TIRES (Page 3-31).
3. Discard sealed wheel bearings. See SEALED WHEEL BEARINGS (Page 3-26).

4. Remove wheel bearing spacer (4).
5. Clean all parts, except bearings and WSS, for inspection.

# 3.4

## CLEAN AND INSPECT

1. Clean all parts thoroughly.
2. Inspect front wheel for damage. Replace or repair as necessary.
3. Check wheel lateral and radial runout before installing a new tire. See CHECKING AND TRUING WHEELS (Page 3-22).

## ASSEMBLE

2. Install new sealed wheel bearings. See SEALED WHEEL

| FASTENER                | TORQUE VALUE |               |
|-------------------------|--------------|---------------|
| Brake disc screw, front | 16-24 ft-lbs | 21.5-32.5 N-m |

1. See Figure 3-3. Install wheel bearing spacer (4).  
BEARINGS (Page 3-26).
3. Install front tire. See TIRES (Page 3-31).
4. Install front brake disc.
  - a. Install front brake disc.
  - b. Cast wheel with standard brake disc: Install spring washers (10) and bushings (9).
  - c. Cast wheel with floating brake disc: See Figure 3-4. Align mark on brake disc center with valve stem hole.
  - d. Install new screws (8). Tighten.  
  
Torque: 16-24 ft-lbs (21.5-32.5 N-m) *Brake disc screw, front*

## COMPLETE

1. Install brake calipers and sensor cable retainer (ABS models). See FRONT BRAKE CALIPER (Page 3-40).
2. ABS models: Secure WSS and fender tip lamp cables with new cable straps. See FRONT WHEEL SPEED SENSOR (WSS) (Page 8-100).
3. Lower front wheel.



## PREPARE

1. Remove saddlebags. See SADDLEBAGS (Page 3-161).
2. Raise rear of motorcycle. See Secure the Motorcycle for Service (Page 2-3).
3. Inspect wheel bearings. See SEALED WHEEL BEARINGS (Page 3-26).
4. Measure brake disc runout. See INSPECT BRAKES (Page 2-19).
5. Measure sprocket isolator wear. See INSPECT REAR SPROCKET ISOLATOR (Page 2-42).
6. Remove left muffler. See MUFFLERS (Page 6-33).
7. Models with manual adjust shock absorbers: Remove left side lower saddlebag support rail. See SADDLEBAG SUPPORTS (Page 3-165).
8. ABS models: Release rear Wheel Speed Sensor (WSS) cable from rear brake hose.
9. Remove rear brake caliper. See REAR BRAKE CALIPER (Page 3-45).

### NOTE

*Do not operate brakes with the caliper removed or the caliper pistons may be forced out. The caliper contains no serviceable components and would require replacement.*

## REMOVE

| PART NUMBER | TOOL NAME               |
|-------------|-------------------------|
| HD-47925    | AXLE NUT TORQUE ADAPTER |

1. Remove axle.
  - a. See Figure 3-5. Remove E-clip (1) from axle (17).
  - b. See Figure 3-7. Using special tool, hold weld nut on left side and loosen cone nut.  
Special Tool: AXLE NUT TORQUE ADAPTER (HD-47925)
  - c. See Figure 3-5. Remove cone nut (2) and adjuster cam (3).
  - d. Rotate weld nut to loosen drive belt.
  - e. Remove axle. Catch external spacers (5, 16), caliper bracket and rear WSS (6) (ABS equipped).
2. **NOTE**
  - Always keep wheel speed sensor (6) and ABS encoder bearing away from magnetic fields.
  - Never pull WSS cable taut or use to retain wheel, axle or other components.

Remove caliper bracket from anchor weldment on rear fork.

3. Remove belt from compensator sprocket (16).
4. **NOTE**  
*Hold sprocket to prevent it from dropping.*

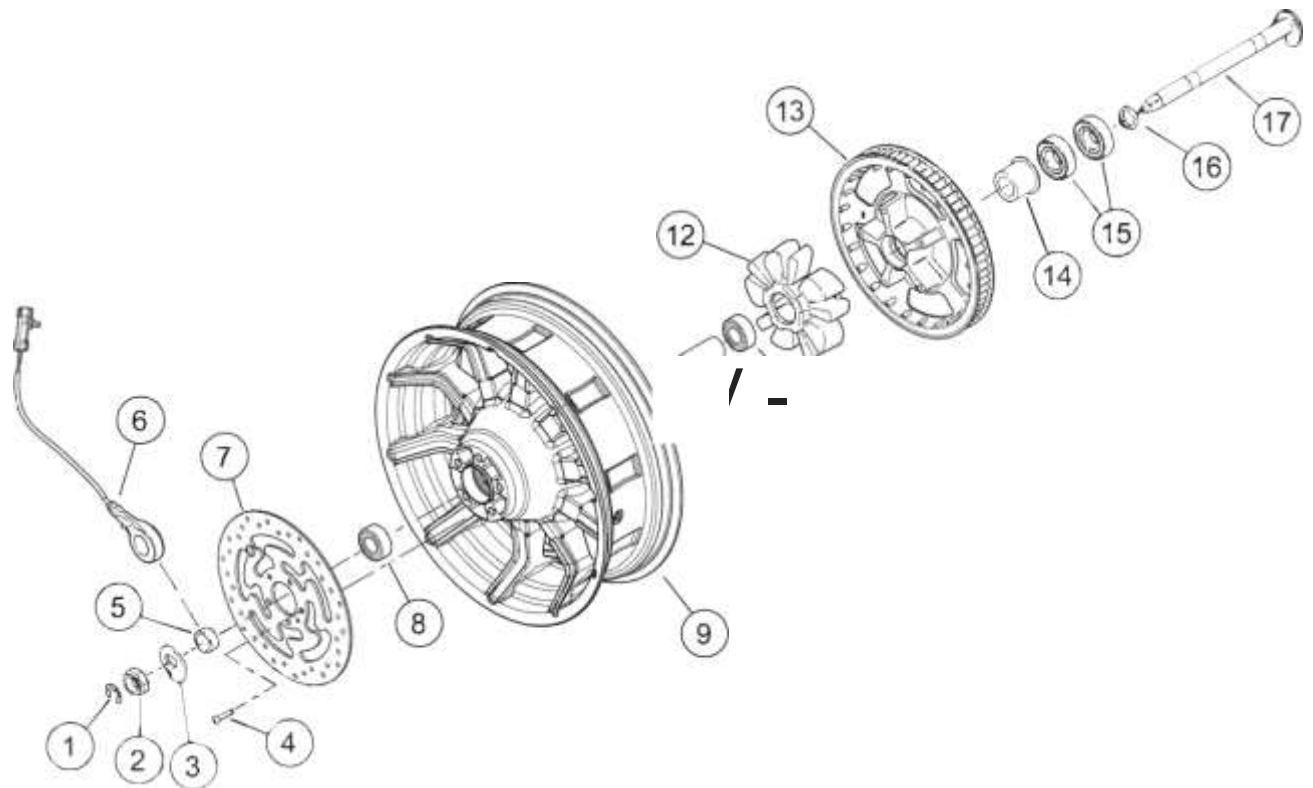
Remove wheel.

## INSTALL

| FASTENER                       | TORQUE VALUE             |
|--------------------------------|--------------------------|
| Rear axle cone nut, 1st torque | 15-20 ft-lbs   20-27 N-m |
| PART NUMBER                    | CONSUMABLE               |
| 98960-97                       | ANTI-SEIZE LUBRICANT     |

1. See Figure 3-6. Inspect caliper bracket. Replace rubber bumper (2) if necessary.
2. See Figure 3-5. Install rear wheel.
  - a. Verify sprocket (13) is fully seated in wheel.
  - b. Place wheel in rear fork.
  - c. Install belt over sprocket.
  - d. Seat caliper bracket on anchor weldment of rear fork.
  - e. Apply anti-seize lubricant to axle (17), bearing bores and bore of spacer sleeve (10).  
  
ANTI-SEIZE LUBRICANT (98960-97)
  - f. Slide axle through left side of rear fork, external spacer (thin) (16), sprocket (13), wheel hub, rear WSS (ABS equipped) or external spacer (thick) (5), caliper bracket and right side of rear fork.
  - g. Rotate axle with flat on threaded end topside.
  - h. Apply a light coat of anti-seize lubricant to inboard face of cone nut (2). Avoid contact with threads.  
  
ANTI-SEIZE LUBRICANT (98960-97)
  - i. Install adjuster cam (3) and cone nut. Finger-tighten only.
3. ABS models: Route WSS cable.
  - a. Route forward and outboard of caliper bracket. Then along top of rear fork.
  - b. See Figure 3-8. Rotate WSS counterclockwise until index pin contacts caliper bracket.
4. Tighten cone nut. Belt adjustment torque.  
  
Torque: 15-20 ft-lbs (20-27 N-m) *Rear axle cone nut, 1st torque*

5. See Figure 3-5. Install new E-clip (1).

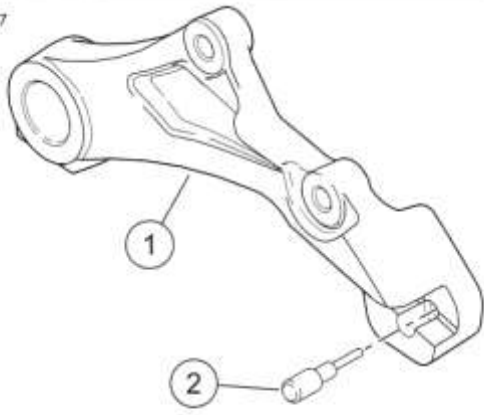


sm07613

- |   |                                  |
|---|----------------------------------|
| 1. E-clip                               | 10. Spacer sleeve                |
| 2. Cone nut                             | 11. Left wheel bearing, standard |
| 3. Adjuster cam                         | 12. Isolator                     |
| 4. Screw (5)                            | 13. Compensator sprocket         |
| 5. External spacer (thick)              | 14. Spacer, compensator          |
| 6. Rear wheel speed sensor              | 15. Sprocket bearing (2)         |
| 7. Brake disc                           | 16. External spacer (thin)       |
| 8. Right wheel bearing, standard or ABS | 17. Axle                         |
| 9. Wheel, typical                       |                                  |

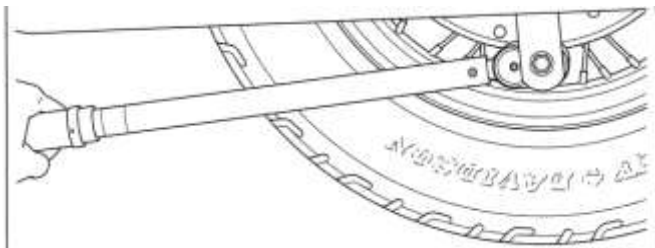
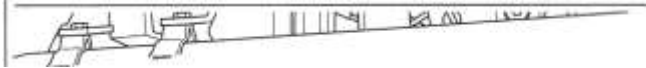
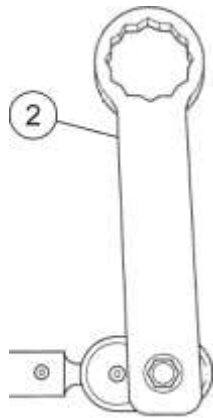
Figure 3-5. Rear Wheel (typical)

sm08577



- 1. Caliper bracket
- 2. Rubber bumper

Figure 3-6. Caliper Bracket



1. Torque wrench
2. Axle nut torque adapter (HD-47925)

Figure 3-7. Install Tool Perpendicular to Torque Wrench

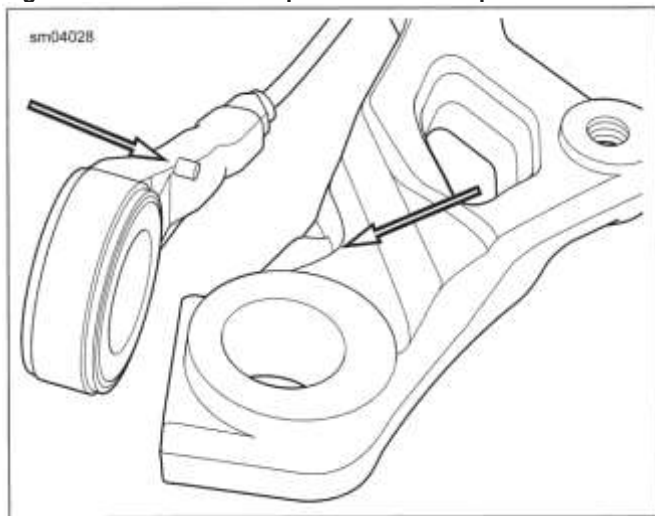


Figure 3-8. Rear Wheel Speed Sensor Index Pin (ABS Equipped)

### DISASSEMBLE

1. Remove sprocket and rubber isolator. See REAR WHEEL COMPENSATOR (Page 3-24).
2. Remove tire. See TIRES (Page 3-31).
3. See Figure 3-5. Remove brake disc (7).
  - a. If wheel is assembled with same disc, mark both wheel and disc so that it can be installed in its original position.

- b. Remove and discard screws (4).
  - c. Remove brake disc.
4. Remove bearings and inner spacer. See SEALED WHEEL BEARINGS (Page 3-26).

### CLEAN AND INSPECT

1. Clean all parts thoroughly.
2. Inspect rear wheel for damage. Replace or repair as necessary.
3. Check wheel runout. See CHECKING AND TRUING WHEELS (Page 3-22).

### ASSEMBLE

| FASTENER         | TORQUE VALUE |           |
|------------------|--------------|-----------|
| Rear rotor screw | 30-45 ft-lbs | 41-61 N-m |

### NOTICE

**Do not re-use brake disc/rotor screws. Re-using these screws can result in torque loss and damage to brake components. (00319c)**

1. *NOTE Install brake disc in its original position.*

Install bearings and inner spacer. See SEALED WHEEL BEARINGS (Page 3-26).

2. See Figure 3-5. Install brake disc (7) and screws (4). Tighten screws in a cross-wise pattern.  
Torque: 30-45 ft-lbs (41-61 N-m) *Rear rotor screw*
3. Install tire. See TIRES (Page 3-31).
4. Install rubber isolator and sprocket (13). See REAR WHEEL COMPENSATOR (Page 3-24).

### COMPLETE

1. Install brake caliper with two screws. Tighten.

| FASTENER            | TORQUE VALUE |           |
|---------------------|--------------|-----------|
| Brake caliper screw | 43-48 ft-lbs | 58-65 N-m |

Torque: 43-48 ft-lbs (58-65 N-m) *Brake caliper screw*

2. Secure rear WSS cable to brake hose. Conduit clip length from front of brake hose crimp:  
1.25 in (31.8 mm)
3. Adjust drive belt deflection. See INSPECT AND ADJUST DRIVE BELT AND SPROCKETS (Page 2-37).
4. Install left saddlebag support rail. See SADDLEBAG SUPPORTS (Page 3-165).
5. Install left muffler. See MUFFLERS (Page 6-33).
6. Install saddlebags. See SADDLEBAGS (Page 3-161).

NOTE

- See Figure 3-9. The following procedure is valid for wheels that use an angle flange hub regardless of rim style or diameter.
- Disc mounting surface for primary brake side of hub has one or two grooves.

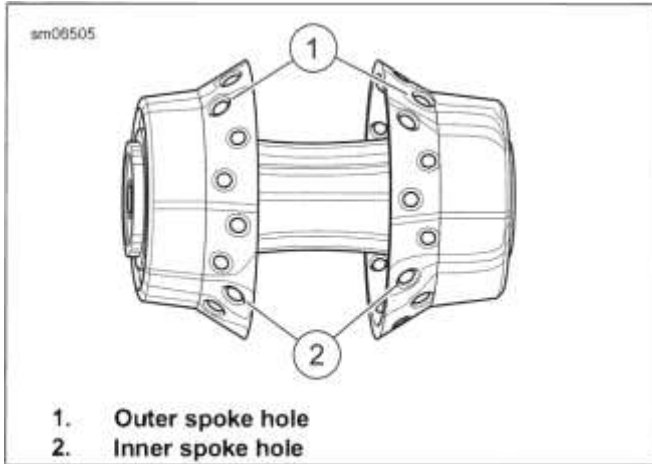


Figure 3-9. Angle Flange Hub

1. Place hub on workbench:
  - a. **Front:** primary brake side up.
  - b. **Rear:** brake side down.
2. Install all spokes in the lower flange.
3. See Figure 3-10. Flip hub over. Gather all outer spokes and hold upright with a rubber band. Repeat with the inner spokes using a second rubber band.
4. Install spokes in remaining flange.
5. Rotate the lower flange spokes as far as they go:
  - a. Outer spokes clockwise.
  - b. Inner spokes counterclockwise.
6. Center the rim over the hub and spokes assembly and support on wooden blocks approximately 1.5 in (38.1 mm) thick.
  - a. If valve is not located in the center of the rim, place valve hole facing up.
  - b. If the valve is located in the center of the rim, it can be placed either side up.

NOTE

Install nipples until approximately 3/4 in (3.2 mm) of spoke thread shows.

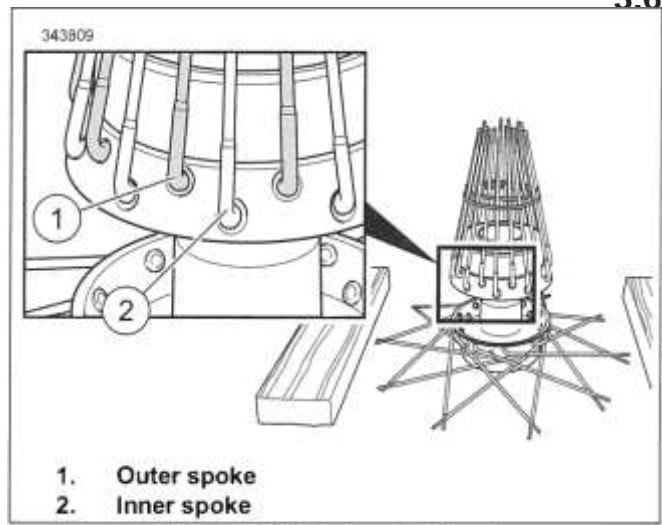
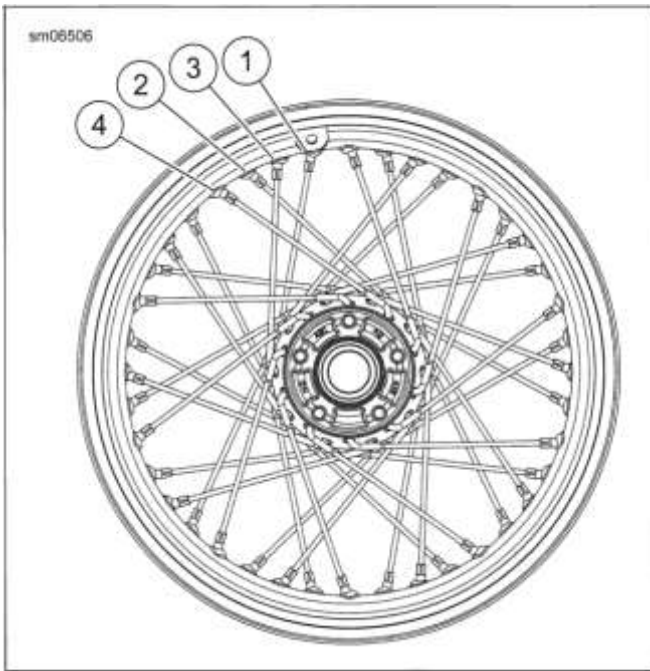
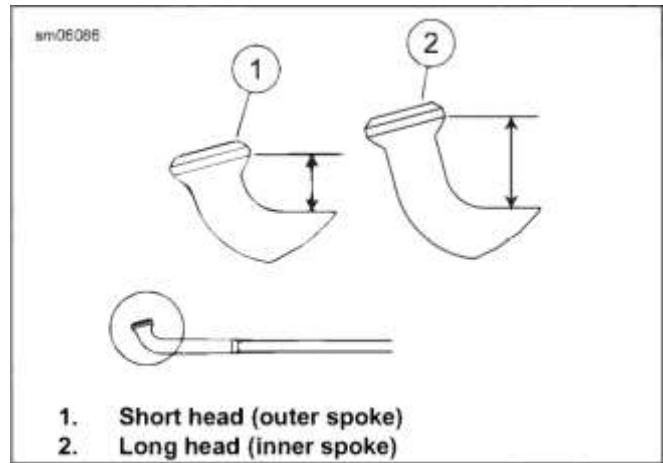


Figure 3-10. Spokes Gathered

7. Install lower flange outer spokes and loosely install spoke nipples:
  - a. **Rim with side valve hole:** See Figure 3-11. Start at the valve stem hole (1).
  - b. **Rim with center valve hole:** See Figure 3-12. Start at the first hole counterclockwise (1) from valve stem hole.
8. Install remaining outer spokes in every fourth hole.
9. Install lower flange inner spokes and loosely install spoke nipples:
  - a. Starting at the second hole counterclockwise (2) from first spoke installed, install inner spoke.
  - b. Install remaining inner spokes in every fourth hole.
10. Carefully release upper flange inner spokes and fan out around rim, rotating them clockwise.
11. Starting at the first hole counterclockwise (3) from first spoke installed, install inner spoke. Install remaining inner spokes in every fourth hole.
12. Carefully release upper flange outer spokes and fan out around rim, rotating them counterclockwise.
13. Install outer spokes in remaining holes (4).
14. Verify that spoke heads are seated. See CHECKING AND TRUING WHEELS (Page 3-22).
  - a. Evenly hand-tighten spoke nipples until snug.
  - b. Only tighten until slack is removed.
  - c. Proper torque is applied when the wheel is trued.
  - d. Adjust offset and true the wheel.

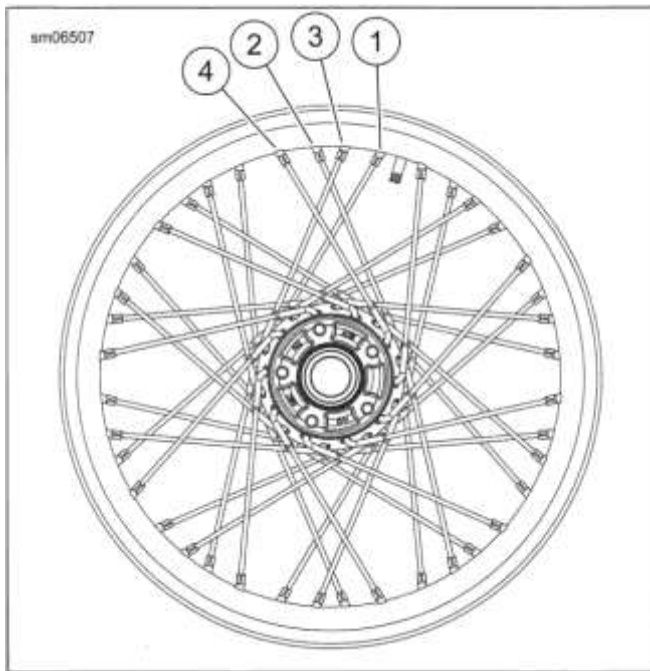


**Figure 3-11. Side Valve Rim**



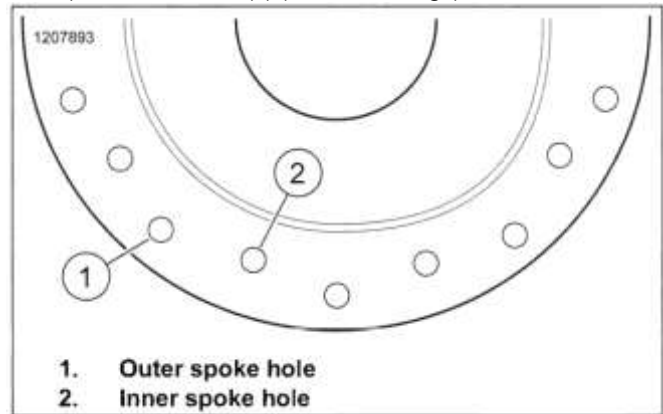
**Figure 3-13. Spoke Heads**

c. See Figure 3-14. The spoke holes in the wheel hub are staggered, alternating between inner holes (2) (nearer hub center) and outer holes (1) (nearer hub edge).



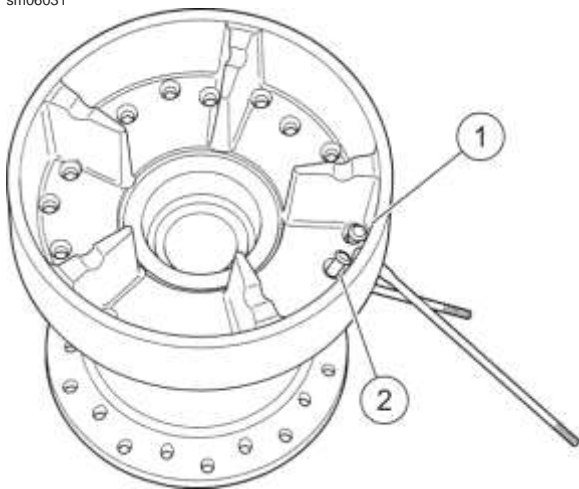
**Figure 3-12. Center Valve Rim**

**LACE WHEEL: 16 IN. REAR WHEEL**



**Figure 3-14. Spoke Hole Pattern**

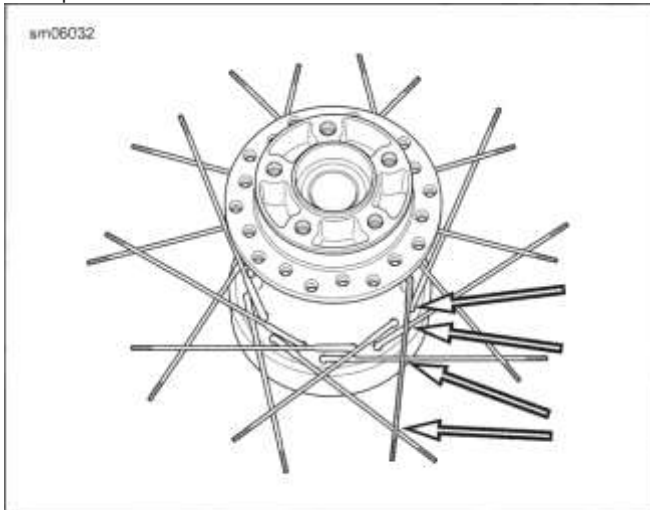
1. See Figure 3-13. Divide spokes into two groups.
  - a. Outer spokes (short heads) (1).
  - b. Inner spokes (long heads) (2).
2. Lubricate all spoke threads and nipple shoulders with tire mounting lubricant.
3. See Figure 3-15. Place hub on workbench with the brake disc side down. Insert outer spokes (1) (short-head) into the outer holes and inner spokes (2) (long-head) in the inner holes.



1. **Outer spoke (short head)**
2. **Inner spoke (long head)**

**Figure 3-15. Lacing Wheel Hub**

4. See Figure 3-16. After spokes are installed, flip wheel hub over. Swing outer spokes counterclockwise and inner spokes clockwise as shown. Each inner spoke crosses four outer spokes, and each outer spoke crosses four inner spokes.



**Figure 3-16. Arrange Spokes**

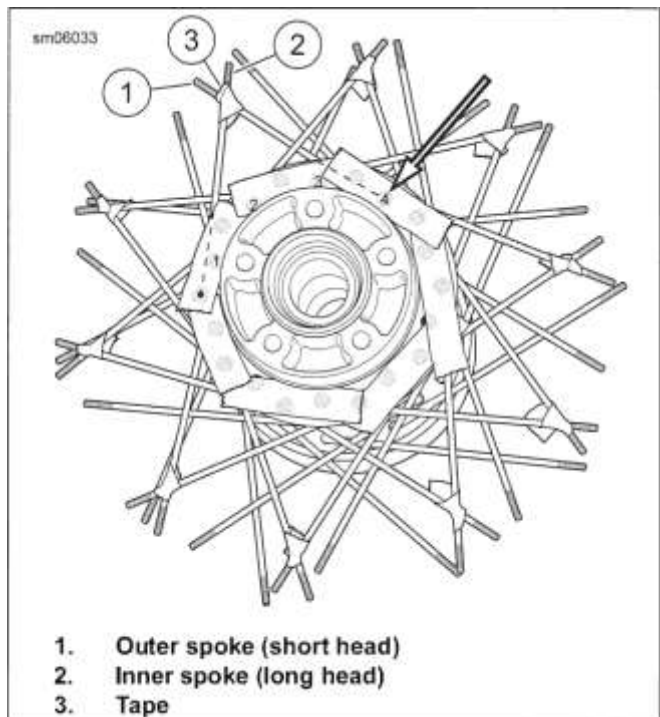
5. Install all outer spokes, then all inner spokes on brake-side flange. Swing inner spokes counterclockwise and outer spokes clockwise on brake-side flange, each crossing four of the opposite types.

6. **NOTE**

See Figure 3-17. Tape placed across brake disc flange and spoke heads hold spokes up away from lower row of spokes, making it easier to gather upper spokes.

See Figure 3-17. Group upper spokes (brake-side) into bundles of two as shown. Join an outer spoke (1) with the inner spoke (2) that is located four places clockwise. Secure tape (3) from threaded end:

1 in (25.4 mm)



1. **Outer spoke (short head)**
2. **Inner spoke (long head)**
3. **Tape**

**Figure 3-17. Bundling Spokes**

7. Make sure that all spokes on compensator-side flange are still arranged properly and pointing in the correct direction:
  - a. All outer spokes (short-head) point counterclockwise, crossing four inner spokes.
  - b. All inner spokes (long-head) point clockwise, crossing four outer spokes (short-head).
  - c. Angle all spokes as far as they will go without overlapping the next LIKE spoke.
8. **NOTE**
  - Verify that all inner spokes lay inboard and outer spokes lay outboard.
  - See Figure 3-18. The valve stem hole location (1) is centered on the rim so rim orientation is not important.

See Figure 3-18. Center the rim over the hub/spoke assembly. Rotate so valve stem hole (1) is near a pair of taped spokes. Support on wooden block (2):

1.5 in (38.1 mm)

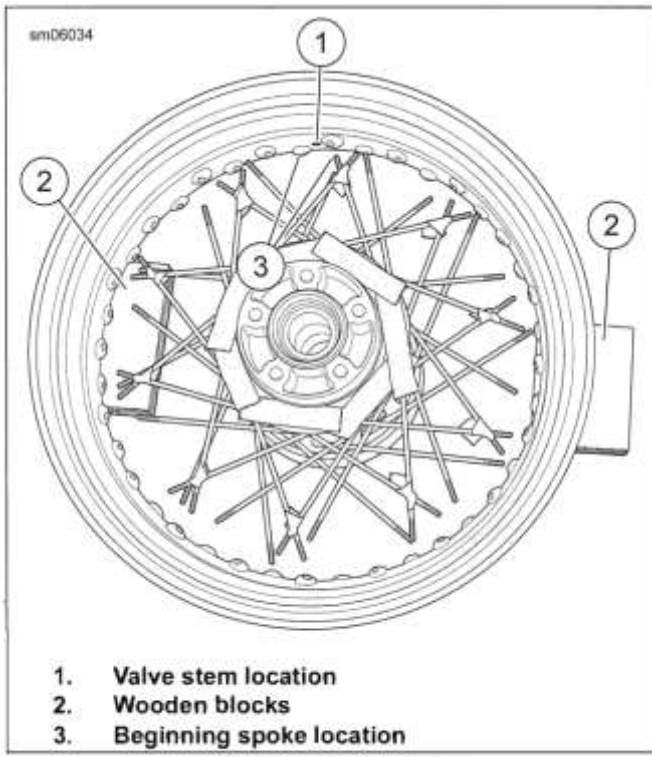


Figure 3-18. Place Rim

9. **NOTE**

See Figure 3-19. It is recommended that the first spoke be installed near the valve stem hole (5). Place spoke nipples through several rim holes to determine the hole direction. Only one spoke will fit into the spoke nipple correctly. When connecting the spoke to the spoke nipple, finger-tighten two to three threads.

See Figure 3-19. Begin with the outer spokes (short-head) of the lower (compensator) flange. Using the spoke alignment method discussed previously, locate a spoke hole (1) just left of the valve stem hole (5) that points toward an outer spoke.

- a. Secure spoke to nipple. Skip three rim holes and repeat with the next outer spoke. Follow pattern to complete lower (compensator) flange outer spokes (short-head).
- b. Once completed, check for three empty holes between each spoke.

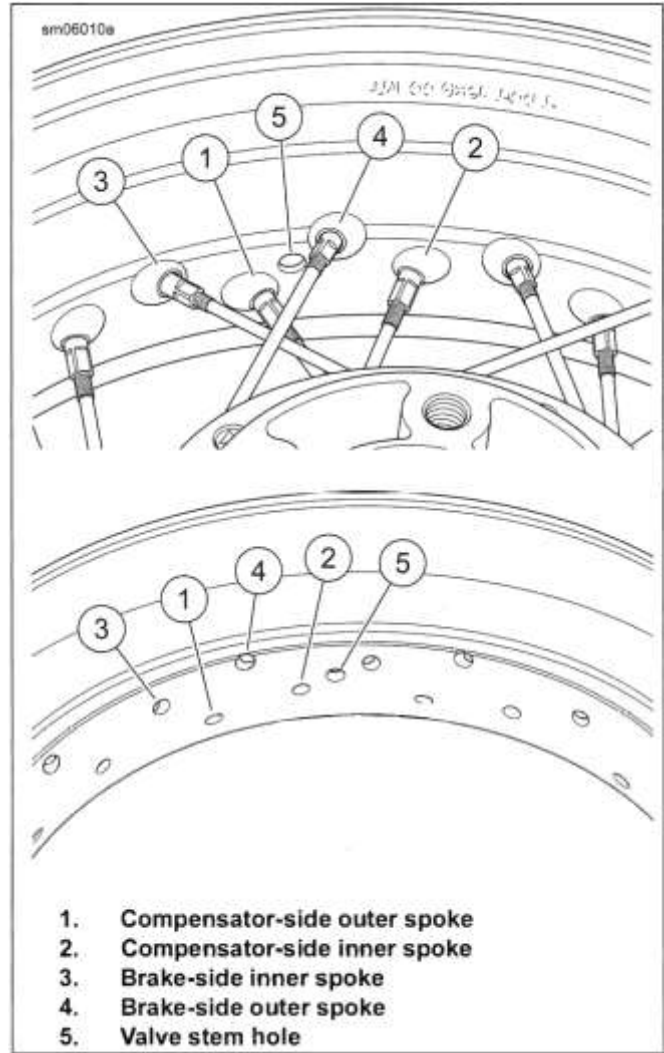


Figure 3-19. Begin Lacing

10. Install the lower (compensator) flange inner spokes (long-head) next. Choose a beginning spoke (2) near the valve stem hole (5).
  - a. Each inner spoke (long-head) points clockwise and crosses four outer spokes (short-head).
  - b. Secure spoke to nipple. Complete installing lower flange inner spokes (long-head).

11. **NOTE**

Do not move outer spokes (short-head) under inner spokes (long-head) when removing the tape or they will become trapped underneath the inner row of spokes.

See Figure 3-18. Remove tape from each upper bundle and fan the spokes out toward the rim.

12. **NOTE**

See Figure 3-19. All upper flange inner spokes (long-head) point counterclockwise and outer spokes (long-head) clockwise.

Choose a beginning spoke near the valve stem hole (5). Start with a brake-side inner spoke (3) (long-head) first.

- a. Secure spoke to nipple. Follow pattern to complete brake-side flange inner spokes (long-head).

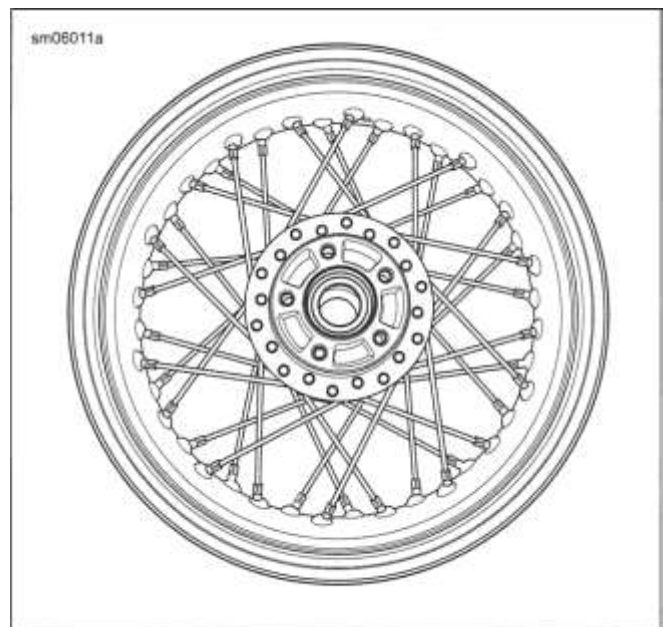


b. Once completed, check for one empty hole after every third spoke.

13. Install brake-side outer spoke (4) (short-head).

14. Secure spoke to nipple. Complete upper flange outer spokes (short-head).

15. See Figure 3-20. Verify that completed wheel resembles.



**Figure 3-20. Completed 16 Inch Rear Wheel**

16. Verify that spoke heads are seated. Evenly hand-tighten spoke nipples until snug. Only tighten until slack is removed. Proper torque is applied when the wheel is trued.

17. Adjust offset and true the wheel. See CHECKING AND TRUING WHEELS (Page 3-22).

Check wheels for lateral and radial runout before installing a new tire.

Cast wheels having excess runout must be replaced. Never attempt to straighten cast wheels.

Always check condition of wheel bearings before checking wheel runout. See SEALED WHEEL BEARINGS (Page 3-26).

## CHECKING WHEEL RUNOUT

Check wheels for both radial runout and lateral runout. If either

| PART NUMBER | TOOLNAME           |
|-------------|--------------------|
| HD-99500-80 | WHEEL TRUING STAND |

measurement is not within specification replace wheel.

### Checking Radial Runout

- See Figure 3-21. Mount wheel in truing stand.  
Special Tool: WHEEL TRUING STAND (HD-99500-80)
- Adjust gauge rod or dial indicator to the rim's tire bead safety hump.
- Rotate wheel and measure distance at several locations. Runout must not exceed dimension.

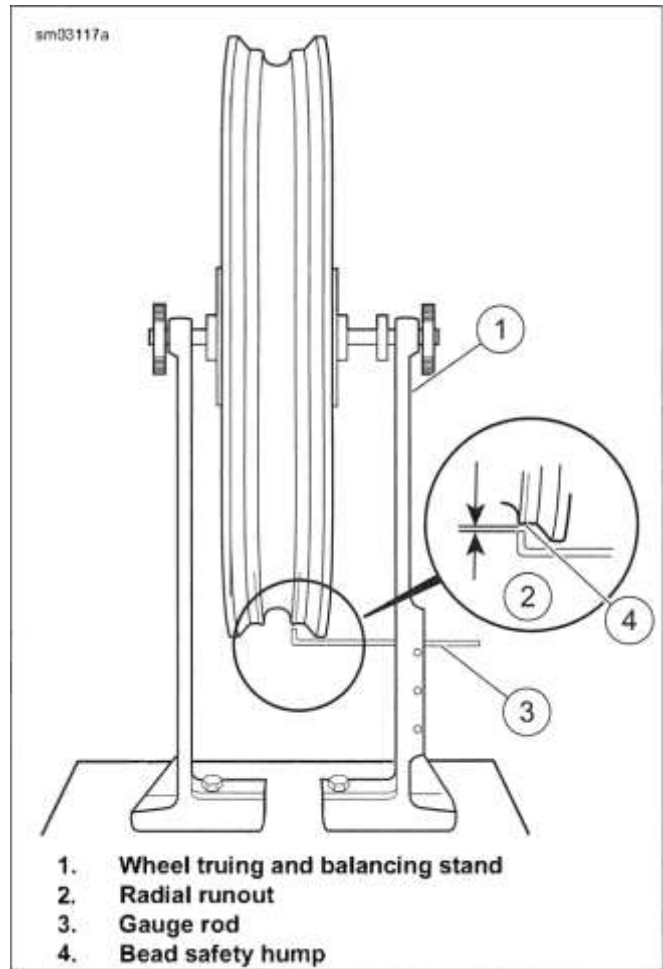


Figure 3-21. Checking Radial Runout

### Checking Lateral Runout

- See Figure 3-22. Mount wheel in truing stand.  
Special Tool: WHEEL TRUING STAND (HD-99500-80)

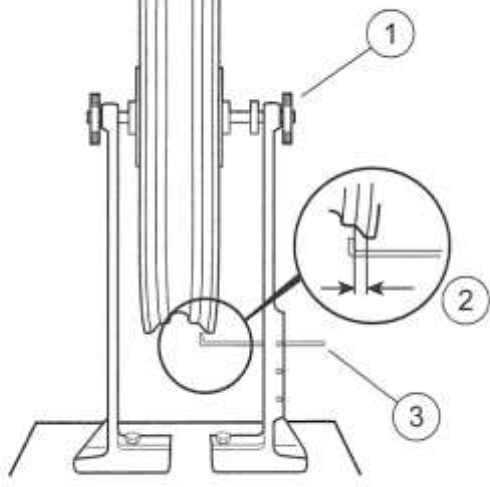
#### 2. NOTE

*Dial indicators are more accurate than gauge rods.*

Place a gauge rod near, or dial indicator on the rim bead flange.

- Measure distance at several locations. Lateral runout must not exceed dimension.

0.030 in (0.76 mm)



- 1. Wheel truing and balancing stand
- 2. Lateral runout
- 3. Gauge rod

Figure 3-22. Checking Lateral Runout

## PREPARE

1. Check compensator sprocket isolator for wear. See REAR WHEEL COMPENSATOR (Page 3-24).
2. Remove rear wheel. See REAR WHEEL (Page 3-14).

## REMOVE

1. See Figure 3-23. Remove rear wheel compensator.
  - a. Pull sprocket (1) from rear wheel (3).
  - b. Remove isolator (2) from wheel. Discard isolator.

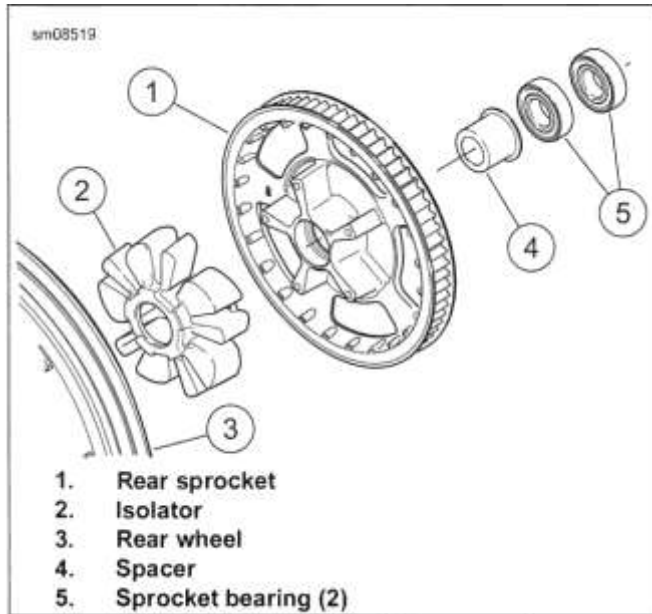


Figure 3-23. Rear Wheel Compensator

## INSTALL

1. Install **new** rear wheel compensator.
  - a. See Figure 3-24. Lubricate each segment (2) of **new** isolator with equal mix of isopropyl alcohol and water.
  - b. Push **new** isolator into wheel. Verify that each isolator segment is completely installed and is flush with each rib (1).
  - c. See Figure 3-23. Push sprocket (1) onto wheel (3).

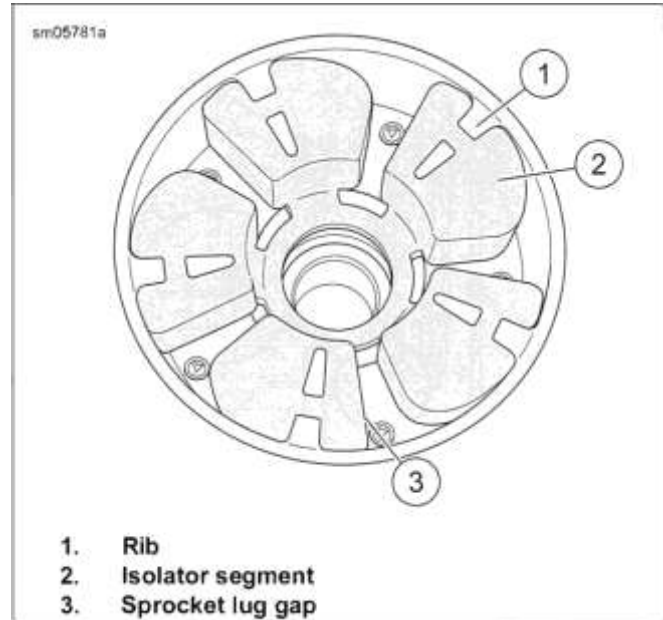


Figure 3-24. Install Isolator in Wheel

## DISASSEMBLE

| PART NUMBER | TOOL NAME   |
|-------------|---|
| HD-48921    | REAR WHEEL COMPENSATOR SPROCKET BEARING REMOVER/INSTALLER |

1. See Figure 3-23. Remove sprocket bearings (5).
  - a. See Figure 3-25. Support the base (1) of REAR WHEEL COMPENSATOR SPROCKET BEARING REMOVER/INSTALLER (PART NUMBER: HD-48921) on a suitable press with the large OD facing up and the long pin facing down.
  - b. Slide sleeve (2) over the short pin.
  - c. Slide the sprocket inboard side up over the sleeve until it rests on the base.
  - d. Slide the small OD of driver (3) over the sleeve until it contacts the spacer.
  - e. Apply pressure to the driver until bearings drop into base.
2. Remove tool.
3. See Figure 3-23. Discard bearings (5).

sm04547

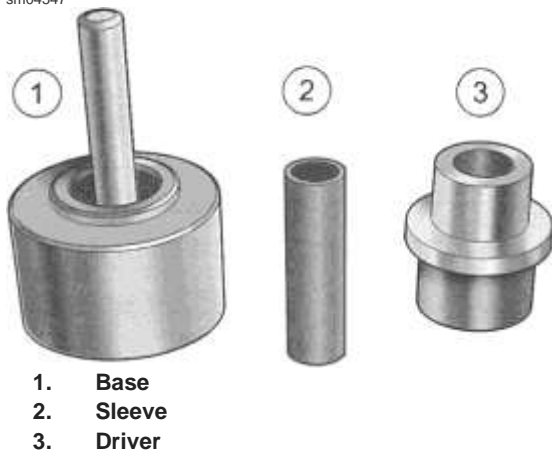


Figure 3-25. Rear Wheel Compensator Bearing Remover/Installer (HD-48921)

### CLEAN AND INSPECT

1. Clean all parts thoroughly. Verify that sprocket bearing bore is clean and dry.
2. Inspect each tooth of the rear wheel sprocket for wear or damage. Replace as necessary. See REAR WHEEL COMPENSATOR (Page 3-24).

### ASSEMBLE

| PART NUMBER | TOOL NAME   |
|-------------|---|
| HD-48921    | REAR WHEEL COMPENSATOR SPROCKET BEARING REMOVER/INSTALLER |

1. See Figure 3-23. Install spacer (4) and **new** sprocket bearings (5).
  - a. See Figure 3-25. Support the base (1) of REAR WHEEL COMPENSATOR SPROCKET BEARING REMOVER/INSTALLER (PART NUMBER: HD-48921) on a suitable press with the large OD facing up and the long pin facing down.
  - b. Slide sleeve (2) over the short pin.
  - c. Slide the sprocket outboard side up over the sleeve until it rests on the base.
  - d. Install spacer in the sprocket with the small diameter facing down.
  - e. Set first **new** bearing in place.
  - f. Center the large OD of driver (3) onto the bearing. Verify that the driver contacts complete radius of the outer bearing race.
  - g. Apply pressure to the driver until the bearing is firmly seated in the counterbore of the sprocket.
  - h. Repeat for second **new** bearing.

### COMPLETE

1. Install rear wheel. See REAR WHEEL (Page 3-14).

## PREPARE

1. Raise front or rear wheel. See Secure the Motorcycle for Service (Page 2-3).

## INSPECT

### NOTICE

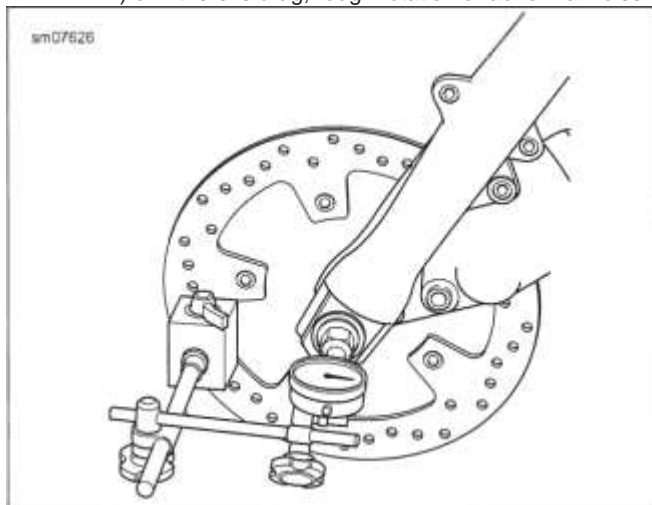
When lifting a motorcycle using a jack, be sure jack contacts both lower frame tubes where down tubes and lower frame tubes converge. Never lift by jacking on cross-members, oil pan, mounting brackets, components or housings. Failure to comply can cause serious damage resulting in the need to perform major repair work. (00586d)

1. Raise the wheel.
2. Turn the wheel through several rotations.

### NOTE

- Keep wheel speed sensor and ABS encoder bearing away from magnetic fields.
- When checking end play, pull or push on the wheel not the brake disc. Pulling or pushing brake disc can distort disc causing a false end play reading.

3. Check end play:
  - a. See Figure 3-26. Mount a magnetic base dial indicator to the brake disc. Set the indicator contact point on the end of the axle.
  - b. Firmly push the wheel to one side. Zero the dial indicator gauge.
  - c. Firmly pull the wheel back. Note the reading of the dial indicator.
  - d. Repeat the procedure to verify the reading.
  - e. Replace the bearings if end play exceeds 0.002 in (0.051 mm) or if there is drag, rough rotation or abnormal noise.



**Figure 3-26. Wheel Bearing Inspection (Front Wheel Shown)**

1. Remove wheel. See FRONT WHEEL (Page 3-12) or REAR WHEEL (Page 3-14).

## REMOVE

### PART NUMBER

- HD-44060-10A
- HD-44060-11A
- HD-44060D

### TOOL NAME

- COLLET
- COLLET
- WHEEL BEARING INSTALLER/REMOVER

2. **Rear wheel:** Remove sprocket.

### NOTE

- Primary side of the wheel is the brake rotor side. For dual disc front wheels, the primary side is the left side.
- Remove the primary side bearing first.

3. See Figure 3-27. Assemble WHEEL BEARING INSTALLER/REMOVER (PART NUMBER: HD-44060D).

- a. Lubricate forcing screw.
- b. Install nut (2), washer (3) and bearing (4) on screw.
- c. Insert assembly through hole in bridge (5).

### NOTE

Choose the appropriate col/et to remove the bearing.

- Non-ABS models: Use COLLET (PART NUMBER: HD-44060-10A).
- ABS models: Use COLLET (PART NUMBER: HD-44060-11A).

4. Install ball bearing inside collet (6). Fasten collet and ball bearing to forcing screw (1).

### NOTE

- See Figure 3-28. If the puller bridge does not have adequate support, place a scrap brake disc having the small center hole to support the puller bridge.
- OE disc removal is not necessary. Place the scrap disc directly over the OE disc mounting screws.
- If the OE disc has been removed, place tape or other protective material between hub and scrap disc to prevent cosmetic damage.

5. Remove bearings.
  - a. See Figure 3-27. Hold end of forcing screw (1) and turn collet (6) to expand edges of collet.
  - b. See Figure 3-29. Hold forcing screw (1) and turn nut (2) to remove bearing.
  - c. See Figure 3-30. Remove spacer sleeve (6) from inside wheel hub.
  - d. Repeat on opposite side.

6. Discard all bearings.

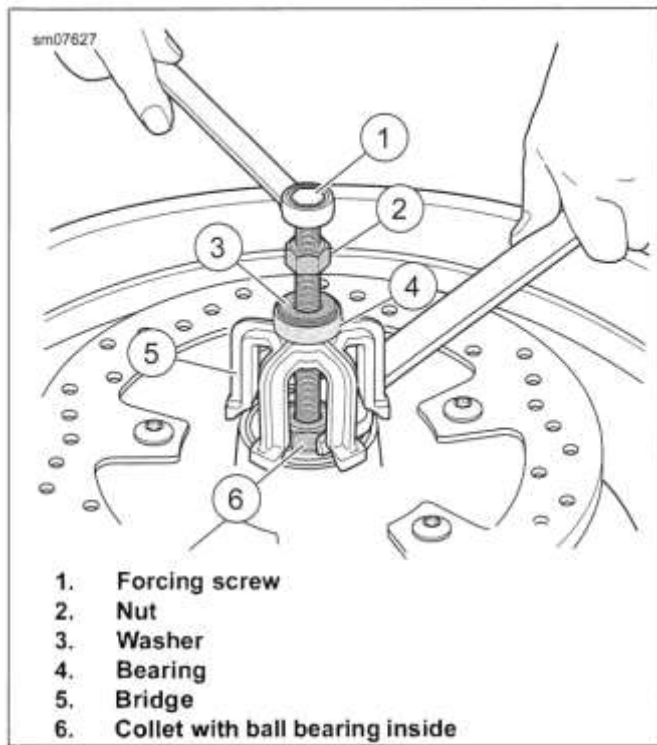


Figure 3-27. Wheel Bearing Removal Tool

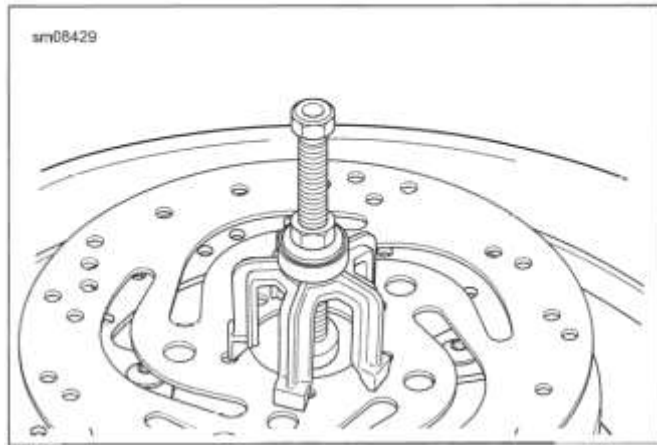


Figure 3-28. Using Scrap Brake Disc

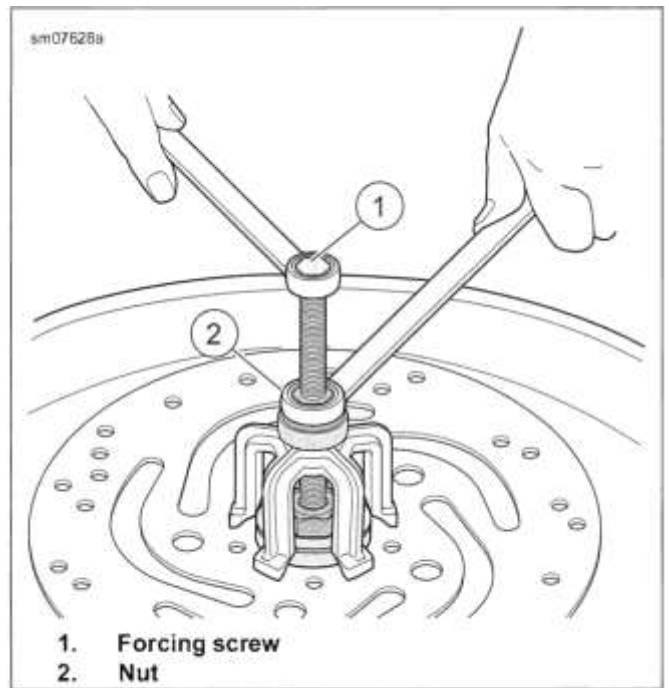
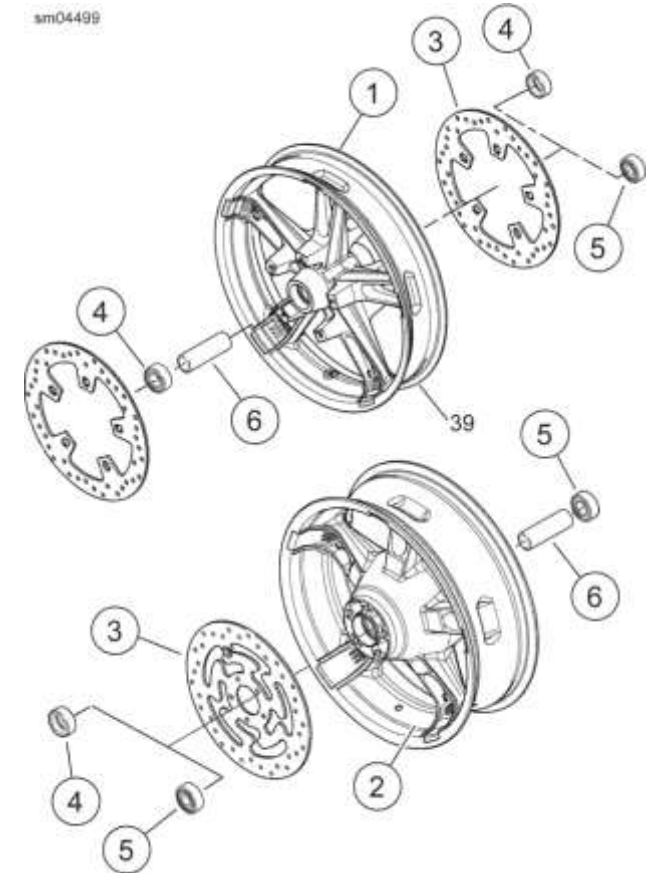


Figure 3-29. Removing Bearing



1. Front wheel
2. Rear wheel
3. Brake disc (primary)
4. ABS encoder bearing
5. Standard bearing
6. Spacer sleeve

Figure 3-30 . Wheel Bearing Assemblies

| PART NUMBER | TOOL NAME                          |
|-------------|------------------------------------|
| HD-44060D   | WHEEL BEARING<br>INSTALLER/REMOVER |

## INSTALL

### NOTICE

Replace both bearing assemblies even if one assembly appears to be good. Mismatched bearings can lead to excessive wear and premature replacement. (00532c)

#### NOTE

- Install first bearing on primary brake disc side of hub.
- Install ABS bearing on the primary brake disc side of the wheel.
- Primary side of the wheel is the brake rotor side. For dual disc front wheels, the primary side is the left side.
- Disc mounting surface for primary brake side of hub has one or two grooves.

1. See Figure 3-31. Assemble WHEEL BEARING INSTALLER/REMOVER (PART NUMBER: HD-44060D).
  - a. Lubricate threaded rod.
  - b. Install support plate (2) onto rod (1).
  - c. Insert assembly through wheel from the side opposite the primary brake side.

#### NOTE

Bearing orientation is important.

2. See Figure 3-32. Place **new** bearing on the rod.
  - a. **Non-ABS bearing:** Lettered side against installer (5).
  - b. **ABS bearing:** Red side against wheel.
  - c. Place 1-inch installer (Part No. HD-44060-8) (5), bearing (4), washer (3) and nut (2) over rod.
3. Install bearings.
  - a. Hold hex end of threaded rod (1) and turn nut (2).
  - b. Bearing is fully seated when nut can no longer be turned.
  - c. Remove tool.
  - d. Install spacer sleeve inside wheel hub.
  - e. Reverse tool.
  - f. Install opposite side bearing until bearing contacts spacer sleeve.

4. **Rear wheel:** Install sprocket.
5. Install wheel. See FRONT WHEEL (Page 3-12) or REAR WHEEL (Page 3-14).

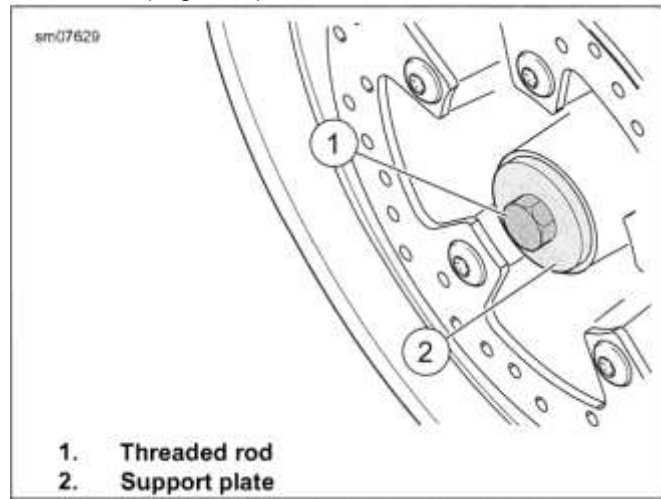


Figure 3-31. Assembling Installation Tool

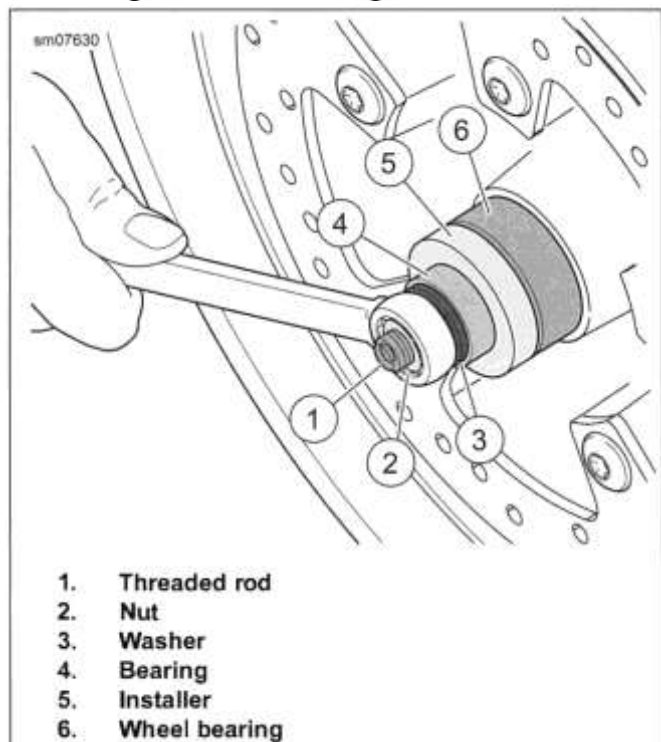


Figure 3-32. Installing Bearings

## COMPLETE

1. Lower wheel.



## GENERAL

### General

Sensors mounted in each tire measure and report tire pressure data to the BCM. The BCM monitors the data and displays each tire pressure both in the Boom! Audio system information screen as well as in the odometer trip display. See the electrical diagnostic manual for more information and diagnostics.

**NOTE**

- Do not use the TPMS as a pressure gauge when adding or removing air from a tire. Sensor transmissions vary with conditions and may not react immediately when adding or removing air from the tire. Over-inflation or under-inflation can result.
- The TPMS sensor will not communicate pressures above 50-60 psi (345-414 kPa) depending on altitude.
- TPMS has been calibrated to use air in the tire. Use of 100% nitrogen may affect the accuracy of the system.

## PREPARE

1. Remove wheel. See FRONT WHEEL (Page 3-12) or REAR WHEEL (Page 3-14).
2. Remove tire. See TIRES (Page 3-31).
3. Check wheels for lateral and radial runout. See CHECKING AND TRUING WHEELS (Page 3-22).

## REMOVE

1. See Figure 3-33. Remove sensor (1 ).
  - a. Remove screw (2).
  - b. Remove valve stem (6) and o-ring (4).
  - c. Remove sensor (1) from wheel.

| FASTENER   | TORQUE VALUE |           |
|------------|--------------|-----------|
| Valve stem | 23-27 in-lbs | 2.6-3 N-m |

## INSTALL

### Install Sensor

1. Clean valve stem mounting location.
2. **NOTE**
  - Tire pressure sensors are designed for use with the wheels specified for the motorcycle. Attempting to use sensors on other wheels can result in lack of proper fitment, TPMS malfunction and air leakage.
  - Sensors with good batteries can be reused.
  - Never install a used valve stem, O-ring or screw.

See Figure 3-33. Install new valve stem and sensor in wheel.

- a. Install tire pressure sensor (1) in slot in wheel.
- b. Install new O-ring (4) on valve stem (6).
- c. Align orientation slot (5) with rail in tire pressure sensor (1).

- See Figure 3-33. New screw (2) has pre-applied threadlocker.

d. While holding valve stem aligned with wheel, tighten.

Torque: 23-27 in-lbs (2.6-3 N-m) *Valve stem*

e. Do not attempt to rotate valve stem once it is installed on wheel.

3. Install the tire. See TIRES (Page 3-31).

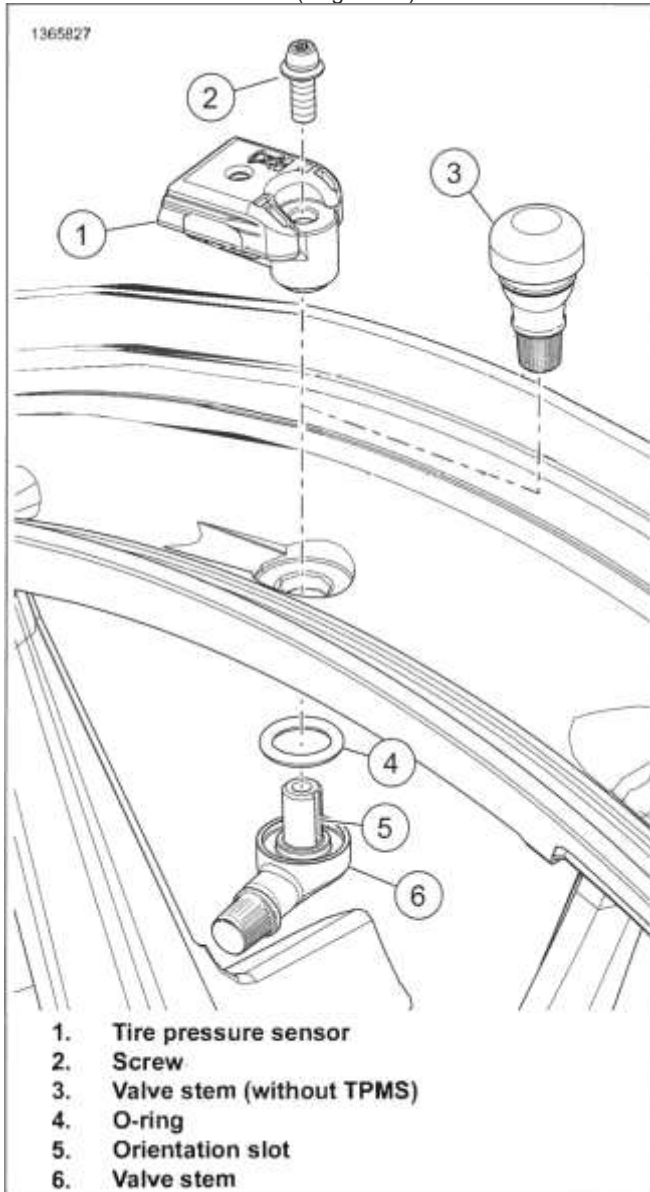


Figure 3-33. Tire Fill Valve/TPMS

| PART NUMBER | TOOLNAME              |
|-------------|-----------------------|
| HD-48650    | DIGITAL TECHNICIAN II |
| HD-51794    | TPMS ACTIVATION TOOL  |

1. Install tire. See TIRES (Page 3-31).

**COMPLETE**

2. *NOTE*

*The sensor must be in PARK mode (have been at rest for approximately 7 minutes) to assign to the vehicle. This includes spin balancing or riding the motorcycle.*

**New sensor:** Before riding motorcycle, assign using TPMS activation tool with Digital Technician II (DT 11).

Special Tool: TPMS ACTIVATION TOOL (HD-51794) Special Tool: DIGITAL TECHNICIAN II (HD-48650)

- a. Connect Digital Technician II to vehicle.
- b. Go to Toolbox> Vehicle Setup > TPMS > Configure. Select sensor assignment.
- c. Follow the online instructions to configure system to recognize sensors.

## GENERAL

### A WARNING

Be sure tires are properly inflated, balanced, undamaged, and have adequate tread. Inspect your tires regularly and see a Harley-Davidson dealer for replacements. Riding with excessively worn, unbalanced, improperly inflated, overloaded or damaged tires can lead to tire failure and adversely affect stability and handling, which could result in death or serious injury. (00014b)

Always maintain proper tire pressure. See INSPECT TIRES AND WHEELS (Page 2-15). Do not load tires beyond GAWR. Refer to tables in SPECIFICATIONS (Page 3-8). Underinflated, overinflated or overloaded tires can fail.

#### NOTE

- Check runout on wheel before installing a new tire. See CHECKING AND TRUING WHEELS (Page 3-22).
- Store new tires on a horizontal tire rack. Storing in a vertical stack compresses the tires and closes the beads.
- Inspect tires for punctures, cuts, breaks and wear at least weekly.
- See Figure 3-34. The tread wear indicators appear when A, in (0.8 mm) or less tread remains. Always replace tires before tread is worn to the indicators.

Replace tire if

- Tread is worn to the tire wear indicators.
- Tire cords or fabric are visible.
- Tire has a bump, bulge or split.
- Puncture that cannot be repaired.

Refer to INSPECT TIRES AND WHEELS (Page 2-15) for recommended tires.

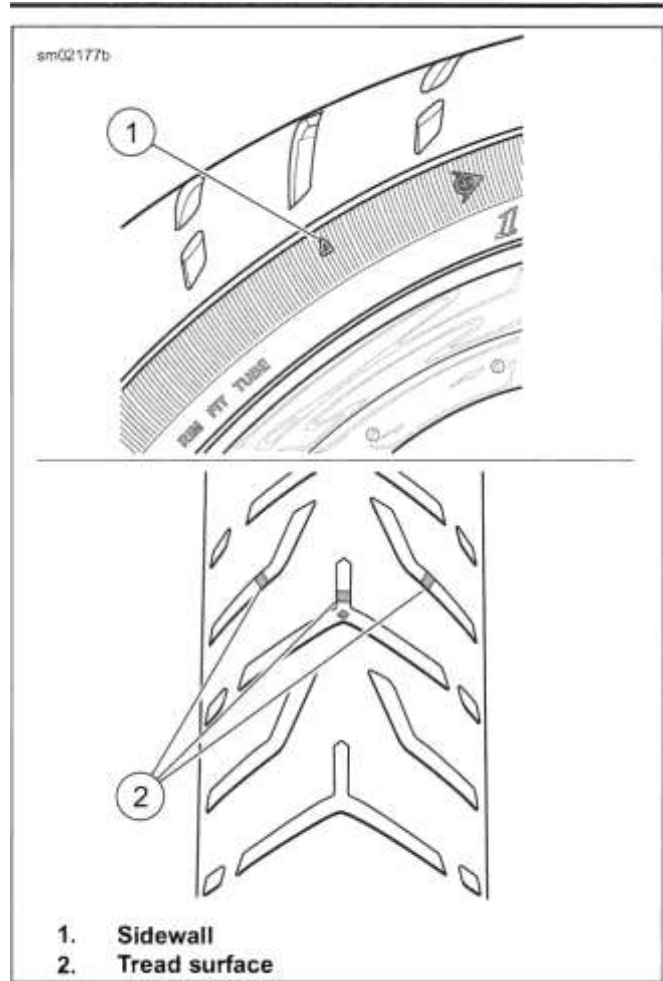


Figure 3-34. Tread Wear Indicators (Typical)

#### NOTE

ABS models must use properly inflated tires and wheels that are the same as the original equipment. The ABS monitors rotational speed of the wheels through individual wheel speed sensors to determine the application of ABS.

Different diameter wheels or tires can:

- Alter the rotational speed which can upset the calibration of the ABS.
- Adversely affect its ability to detect and prevent lockups.

Operating with over- or under-inflated tires can reduce ABS performance.

## PREPARE

1. Remove wheel. See FRONT WHEEL (Page 3-12) or REAR WHEEL (Page 3-14).
2. Check wheels for lateral and radial runout. See Checking Wheel Runout (Page 3-22).

## REMOVE

#### NOTE

- Wheels equipped with tire pressure sensors require special tire mounting and dismounting procedures. Failure to follow these procedures results in damaged sensors.

- Never allow tire machine spoon, tire iron or tire bead to contact sensor. Sensor damage will occur.

**NOTE**

Take care when replacing tire to prevent cosmetic damage to wheel.

**Models With TPMS**

1. **NOTE**

Break the bead being careful to not damage tire pressure sensor.

See Figure 3-36. Engage tire machine spoon (1) 30 degrees (4) from the valve stem (2) in the direction of tire machine rotation (3).

2. While rotating wheel away from valve stem, remove the first bead.
3. Repeat with remaining bead. Remove tire.

**Models Without TPMS**

1. Deflate tire.
2. Loosen both tire beads from rim flange.
3. Remove tire.

**CLEAN, INSPECT \_AND\_ REPAIR**

1. Clean.
  - a. Clean the inside of tire and outer surface of tube.
  - b. Clean rim bead area with a stiff wire brush.
2. Inspect.
  - a. Verify that wheel is true. See CHECKING AND TRUING WHEELS (Page 3-22).
  - b. Check tire tread depth.
  - c. Inspect tire for punctures or tears. Small punctures can be repaired.

**A WARNING**

Replace punctured or damaged tires. In some cases, small punctures in the tread area may be repaired from within the removed tire by a Harley-Davidson dealer. Speed should NOT exceed 50 mph (80 km/h) for the first 24 hours after repair, and the repaired tire should NEVER be used over 80 mph (129 km/h). Failure to follow this warning could lead to tire failure and result in death or serious injury. (00015b)

**3. Repair.**

- a. Patch inner tubes only as an emergency measure. Replace a damaged or patched tube as soon as possible.
- b. Repair tread on tubeless tires if puncture is 3/8" (6.4 mm) or smaller.
- c. Make repairs from inside the tire.
- d. Always combine a patch and plug when repairing tire.

**INSTALL \_\_\_\_\_**

| FASTENER       | TORQUE VALUE |             |
|----------------|--------------|-------------|
| Valve stem nut | 12-15 in-lbs | 1.4—1.7 N-m |

**A WARNING**

Harley-Davidson recommends the use of its specified tires. Harley-Davidson vehicles are not designed for operation with non-specified tires, including snow, moped and other special-use tires. Use of non-specified tires can adversely affect stability, handling or braking and lead to loss of vehicle control, which could result in death or serious injury. (00024d)

**A WARNING**

Harley-Davidson front and rear tires are not the same. Interchanging front and rear tires can cause tire failure, which could result in death or serious injury. (00026a)

**A WARNING**

Do not exceed manufacturer's recommended pressure to seat beads. Exceeding recommended bead seat pressure can cause tire rim assembly to burst, which could result in death or serious injury. (00282a)

For tire pressures, refer to INSPECT TIRES AND WHEELS (Page 2-15).

**NOTE**

- Mount tires with arrows molded into the tire sidewall pointing in the direction of forward rotation.
- If tire has a balance dot on the sidewall, align the balance dot with the valve stem.

**Tube-Type Tires**

**A WARNING**

Match tires, tubes, rim strips or seals, air valves and caps to the correct wheel. Contact a Harley-Davidson dealer. Mismatching can lead to tire damage, allow tire slippage on the wheel or cause tire failure, which could result in death or serious injury. (00023c)

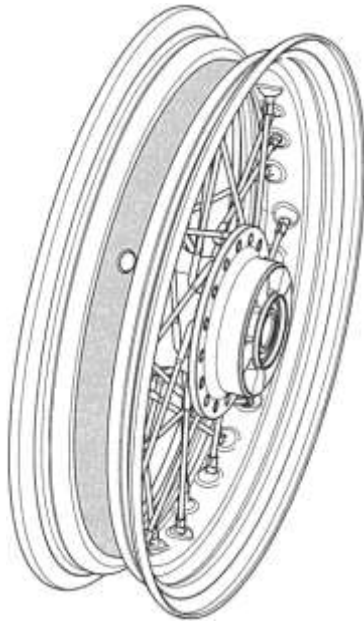
**NOTE**

- For correct tire and tube types, see SPECIFICATIONS (Page 3-8).
- When replacing a tube-type tire, replace the inner tube and rim strip.<sup>4</sup>

<sup>4</sup> Always use a rim strip on tube-type laced wheels.

1. See Figure 3-35. **Tube-type laced wheels:**
  - a. Verify that no spokes protrude through nipples.
  - b. Install a **new** rim strip.
  - c. Align the valve stem hole in rim strip with valve stem hole in rim.
  - d. Install **new** tube and tire.
2. Balance wheel. See Balance in this section.
3. Check tire lateral and radial runout. See Checking Wheel Runout in this section.
4. Install wheel. See FRONT WHEEL (Page 3-12) or REAR WHEEL (Page 3-14).

sm02466a



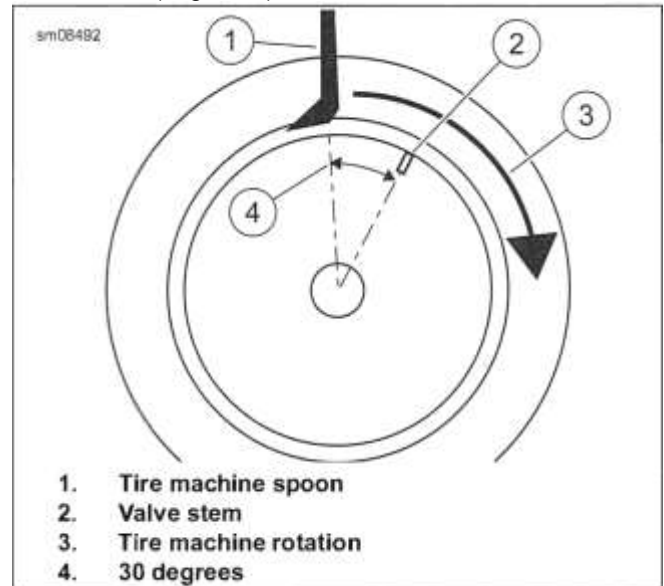
**Figure 3-35. Installed Rim Strip**

### Tubeless-Type With TPMS

1. **NOTE**
  - *Wheels equipped with tire pressure sensors require special tire mounting and dismounting procedures. Failure to follow these procedures results in damaged sensors.*
  - *Never allow tire machine spoon, tire iron or tire bead to contact sensor. Sensor damage will occur.*

See Figure 3-36. Install tire on wheel.
2. Start the first bead opposite from the valve stem.
3. Install first bead.
4. Engage the second bead 30 degrees from the valve stem in the direction of machine rotation.
5. While rotating away from the valve stem, install the second bead.

6. Inflate to the correct pressure. Refer to INSPECT TIRES AND WHEELS (Page 2-15).



**Figure 3-36. Tire Machine Operation**

### Tubeless-Type Without TPMS

#### A WARNING

**Only install original equipment tire valves and valve caps. A valve, or valve and cap combination, that is too long or too heavy can strike adjacent components and damage the valve, causing rapid tire deflation. Rapid tire deflation can cause loss of vehicle control, which could result in death or serious injury. (00281a)**

Replace damaged or leaking valve stems.

1. See Figure 3-37. Metal valve stem.
  - a. Install rubber grommet (5) on valve stem.
  - b. Insert valve stem into rim hole.
  - c. Install metal washer (4) and nut (3). Tighten. Torque: **12-15 in-lbs (1.4-1.7 N-m) Valve stem nut**
2. Rubber valve stem.
  - a. Cut old valve stem to remove.
  - b. Install new valve stem.
  - c. Verify that valve stem is securely seated.
3. Install tire.
4. Balance wheel. See Balance (Page 3-34).

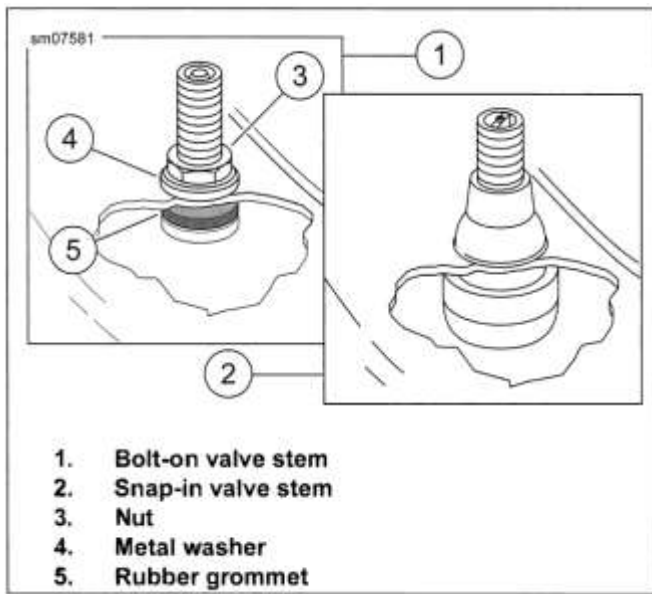


Figure 3-37. Tubeless Tire Valve Stems

## CHECK TIRE RUNOUT

### Lateral Runout

**NOTE**

- Measure runout with wheel installed on motorcycle or using a wheel stand.
- Avoid measuring on raised letters or vents.

1. Check tire pressure.
2. See Figure 3-38. Spin the wheel and measure lateral runout from a fixed point to a smooth area on the tire sidewall.
3. If lateral runout exceeds dimension shown, remove tire from rim and check rim lateral runout. See CHECKING AND TRUING WHEELS (Page 3-22).  
0.090 in (2.29 mm)
  - a. If rim runout is within specification, replace faulty tire.
  - b. If rim runout is not within specification, replace wheel. See CHECKING AND TRUING WHEELS (Page 3-22).

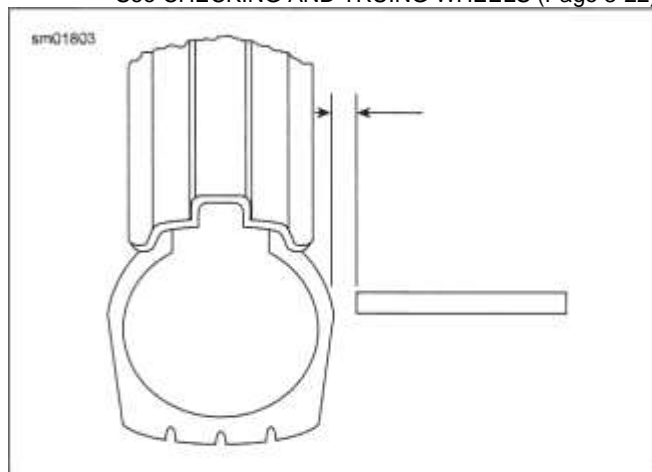


Figure 3-38. Checking Tire Lateral Runout

### Radial Runout

1. Check tire pressure.

2. See Figure 3-39. Spin the wheel on the axle and measure radial runout at the tread centerline.
3. If tire runout exceeds dimension, remove tire from rim and check rim radial runout. See CHECKING AND TRUING WHEELS (Page 3-22).
  - 0.090 in (2.29 mm)
  - a. If rim runout is within specification, replace faulty tire.
  - b. If rim runout is not within specification, replace wheel. See CHECKING AND TRUING WHEELS (Page 3-22).

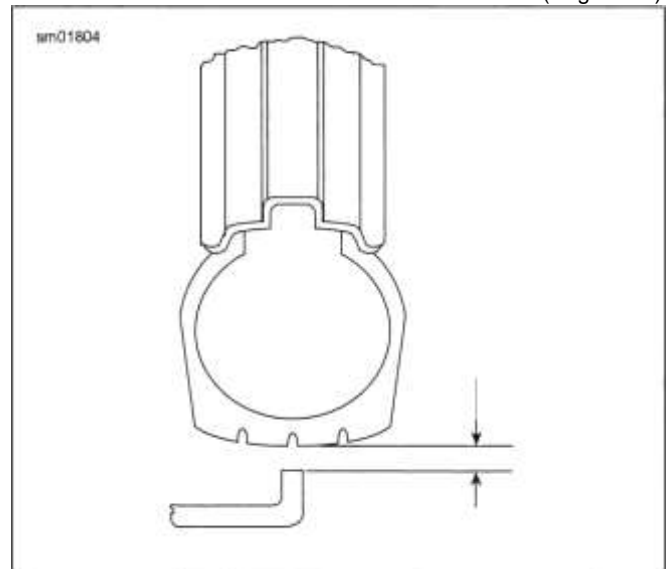


Figure 3-39. Checking Tire Radial Runout

## BALANCE

### Static versus Dynamic

Wheel balancing is recommended to improve handling. Balancing wheels reduces vibration especially at high speeds.

Static balancing will produce satisfactory results for normal highway speeds. Dynamic balancing can produce better results for deceleration.

### Weights

The maximum weight permissible to accomplish balance is 3.5 oz (99.2 g) (total weight applied to the rim). If more than 3.5 oz (99.2 g) of weight is required, rotate the tire 180 degrees on the rim and again balance the assembly. Balance wheels to within 0.5 oz (14 g).

All wheel weights currently supplied by Harley-Davidson are made from zinc which is lighter than lead. The weight of each zinc segment is 0.18 oz (5 g) as compared to 0.25 oz (7 g) for lead. Weights are stamped for easy identification.

**NOTE**

- If adding more than 1.5 oz (43 g) of weight at one location, divide the amount so that half is applied to each side of rim.

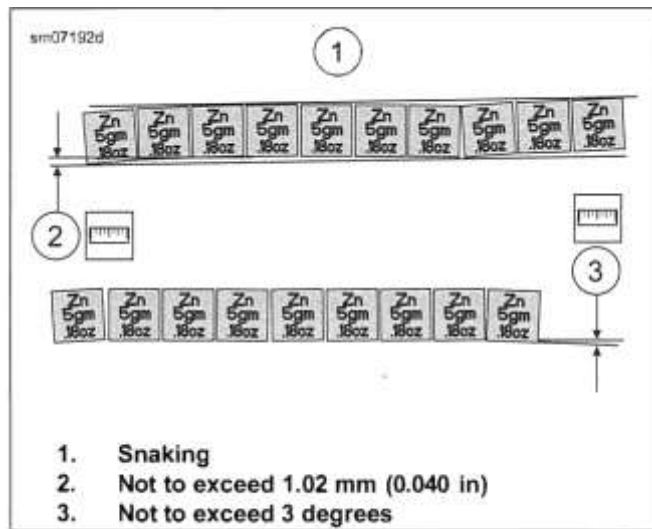
- On cast wheels without a fat area near the bead, place the weights crosswise through the opening.

1. See Figure 3-41. Place weights on a smooth surface of the wheel rim such that centrifugal force will help keep them in place. Make sure the area of application is completely clean, dry, and free of oil and grease.

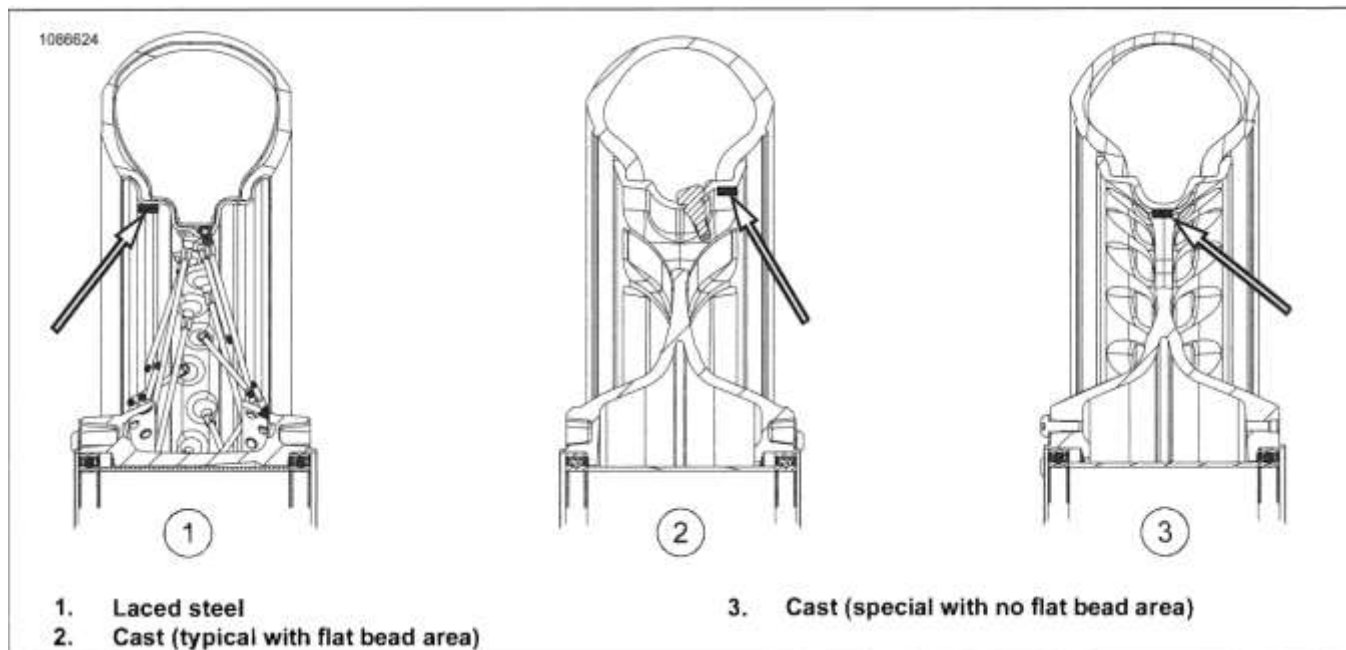
**NOTE**

See Figure 3-40. When installing wheel weights, consider cosmetics. Keep snaking (1) within 0.040 in (1.02 mm) (2) of straight. Also keep the angle alignment of individual segments (3) within 3 degrees.

2. Remove paper backing from the weight. Press firmly in place and hold for ten seconds.



**Figure 3-40. Weight Segment Alignment**



**Figure 3-41. Wheel Weight Placement**

**COMPLETE**

1. Install wheel. See FRONT WHEEL (Page 3-12) or REAR WHEEL (Page 3-14).



## REFLEX DEFENSIVE RIDER SYSTEM (RDRS)

### Linked Braking with Anti-Lock Brake System (ABS)

For information about the ABS system, see ABS MODULE (Page 3-58).

### RDRS Components<sup>1</sup>

RDRS use several components to match performance to available traction and enhance the rider's control of the vehicle.

The braking system includes the following:

**Wheel Speed Sensor (WSS) (front and rear):** Reports wheel speed data directly to the ABS module.

**Inertial Measurement Unit (IMU):** Reports lateral, longitudinal, and vertical acceleration, as well as roll, yaw, and pitch to ABS module, ECM and BCM.

**ABS Module:** The ABS Module collects data from IMU and each WSS. Communicates with ECM and BCM to manage brake application under extreme stopping and cornering conditions. Controls Linking function described below.

When ABS is activated, the solenoid valves decrease, hold or increase hydraulic fluid pressure to control the individual calipers of each wheel to prevent wheel slipping.

### Traction Control System (TCS)

Traction control is selectable and can be turned off.

The cornering traction control system stored in the ABS module constantly monitors the IMU and WSSs to observe the vehicles lean angle during turns, and will adjust torque to the drive wheel by sending a signal to the ECM to reduce throttle input when it senses excessive rear wheel slip, or when necessary to improve vehicle control while cornering.

During start up, the traction-control and ABS lamps flash simultaneously indicating that both systems are waiting for the vehicle to complete a wheel speed sensor check. The traction control system is operational after startup even during the wheel speed sensor check. The traction control lamp should turn off when the sensor check is complete.

### Propulsive Torque Management (PTM)

PTM functionality follows traction control status.

PTM limits the rate of torque increase available as a function of the vehicle position, such as under a cornering condition (lean angle). PTM works off of inputs from the IMU and WSSs and is a function of TCS. When system detects that excessive throttle is being applied for conditions, the ABS module will request a reduction in engine torque.

### Drag-Torque Slip Control System (DSCS)

The ABS module monitors rear wheel slip via the WSSs during a downshift or with throttle closed. When the ABS module detects this condition, a torque command signal is sent to the ECM until the rear wheel is no longer slipping. DSCS functions at speeds over approximately 10 mph (16 km/h) and works with the ABS system to balance vehicle deceleration and rider control. DSCS is not selectable and cannot be disabled.

If the DSCS senses rear wheel slip because of powertrain deceleration it may decrease drag torque, by increasing engine rpm (Revolutions per minute), to limit slip and maintain control.

DSCS function is not adjusted for lean angle, performance of this feature was developed for straight-line use.

### Vehicle Hold Control (VHC)

VHC uses the ABS module to hold brake pressure to keep the motorcycle from rolling backward when it is stopped on an incline.

The ABS module senses the additional brake line pressure applied by the rider to activate VHC. VHC will activate when WSSs sense that vehicle is not moving, jiffy stand is up (vehicles equipped with jiffy stand sensor), transmission is in gear (vehicles not equipped with jiffy stand sensor) and engine is running.

The system holds brake pressure until deactivated by rider pulling away from stop, lowering jiffy stand (vehicles equipped with jiffy stand sensor), shifting into neutral (vehicles not equipped with jiffy stand sensor), engine shutting off or auto deactivation from time or excessive heat in system.

## PREPARE

**NOTE**

If DOT 4 brake fluid contacts painted surfaces, **IMMEDIATELY** flush area with clear water.

1. Remove main fuse. See FUSES AND RELAYS (Page 8-6).
2. FLHRXS: Remove front turn signal lamp and mirror. See MIRRORS (Page 3-132).
3. Drain brake fluid.
  - a. Remove reservoir cover.
  - b. Remove banjo bolt from master cylinder
  - c. Discard sealing washers.
  - d. Drain into container.
  - e. Wrap banjo fitting with shop towel to absorb loss of fluid.

## REMOVE

1. See Figure 3-42. Remove screws (3).
2. Remove clamp (4). Remove hand control assembly.

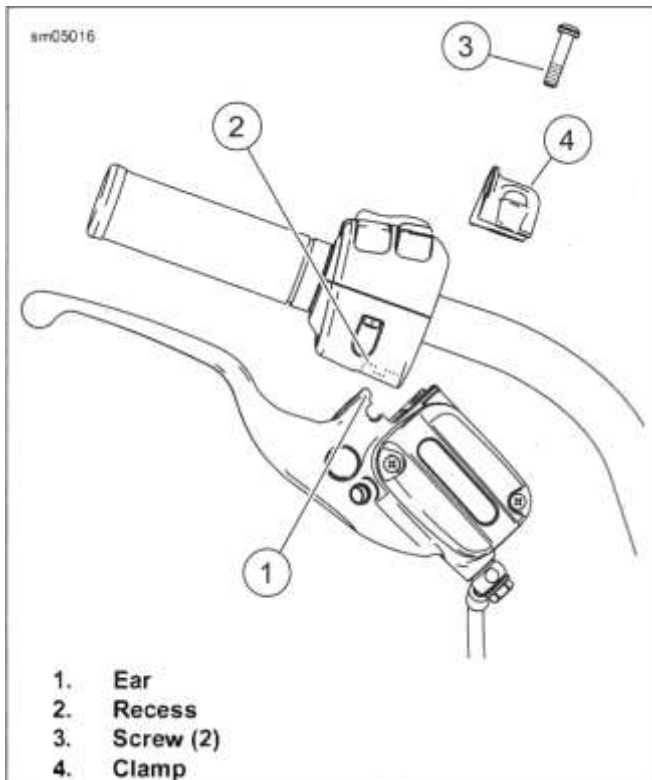


Figure 3-42. Hand Control Assembly (typical)

**NOTICE**

Avoid leakage. Be sure gaskets, banjo bolt(s), brake line and master cylinder bore are clean and undamaged before assembly. (00322a)

## INSTALL

| FASTENER                          | TORQUE VALUE |               |
|-----------------------------------|--------------|---------------|
| Front master cylinder banjo bolt  | 17-19 ft-lbs | 23.1-25.8 N-m |
| Front master cylinder clamp screw | 60-80 in-lbs | 6.8-9 N-m     |

1. See Figure 3-42. Engage ear (1) in recess (2).
2. Install clamp (4).
  - a. Install screws (3).
  - b. Position for rider comfort.
  - c. Tighten top screw then bottom.
 

Torque: 60-80 in-lbs (6.8-9 N-m) *Front master cylinder clamp screw*
3. Install brake line.
  - a. Install banjo bolt, brake line and new sealing washers.
  - b. Verify that the line does not touch the handlebar or fairing when handlebar is turned. Adjust as needed and tighten.
 

Torque: 17-19 ft-lbs (23.1-25.8 N-m) *Front master cylinder banjo bolt*

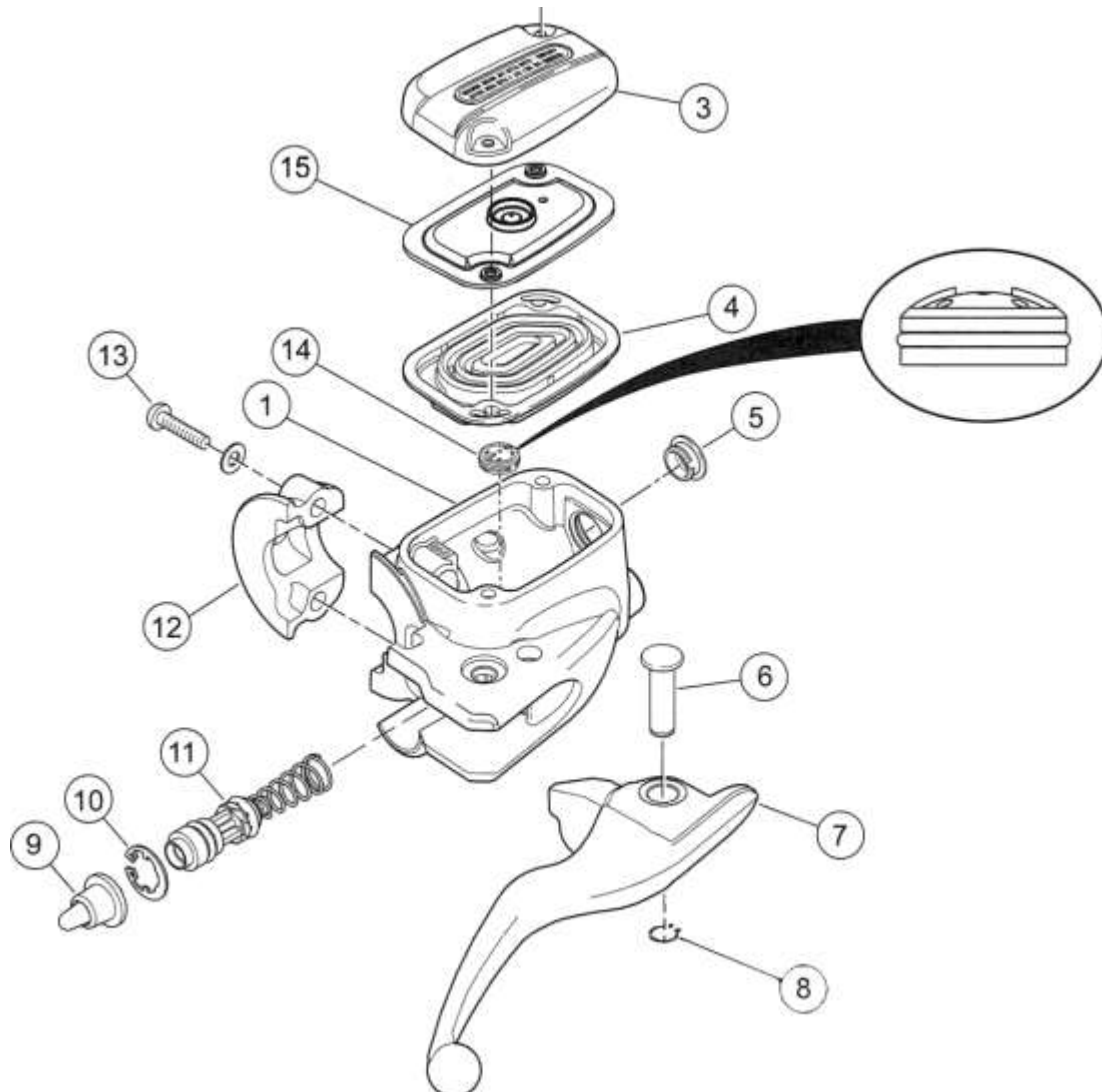
## DISASSEMBLE

**NOTE**

Do not scratch or nick banjo sealing surface during handling.

1. See Figure 3-43. Remove retaining ring (8). Discard retaining ring.
2. Remove pivot pin (6) and brake lever (7).
3. Remove dust boot and pushrod assembly (9).
4. While holding pressure against piston assembly (11), remove retaining ring (10).
5. Remove and discard piston assembly and spring.
6. If necessary, remove anti-bubble button (14).

# 0-J



1. Master cylinder reservoir
2. Cover screw (2)
3. Cover
4. Gasket
5. Sight glass/O-ring
6. Pivot pin
7. Brake hand lever
8. Retaining ring

9. Pushrod/dust boot
10. Retaining ring
11. Piston assembly
12. Handlebar clamp
13. Clamp screw (2)
14. Anti-bubble button
15. Baffle: Painted master cylinders only

Figure 3-43. Front Brake Master Cylinder Assembly

## CLEAN AND INSPECT <sup>5 6</sup>

### A WARNING

Use denatured alcohol to clean brake system components. Do not use mineral-based solvents (such as gasoline or paint thinner), which will deteriorate rubber parts even after assembly. Deterioration of these components can cause brake failure, which could result in death or serious injury. (00291a)

<sup>6</sup> Even residual mineral-based oils and grease can deteriorate rubber brake components.

- Wash hands before handling brake components.
- Never use oily rags to wipe brake components.

1. Clean all parts thoroughly.
2. Using a clean air supply, clear piston bore, reservoir and drilled passages. Do not use a wire or similar instrument.
3. Inspect parts for wear or damage.
  - a. Inspect banjo seating surface for scratches or nicks.
  - b. Inspect piston bore.
  - c. Inspect dust boot retaining groove.
  - d. Inspect dust boot and reservoir cover gasket.
  - e. Inspect lever and pivot pin.

*NOTE*

*Never install a used piston assembly or spring. Always install new parts.*

1. See Figure 3-43. Lightly lubricate piston bore and OD of piston seals with DOT 4 BRAKE FLUID.
2. Install new piston assembly (11).
  - a. Push and hold piston assembly into bore.
  - b. Install new retaining ring (10) with the flat side in.
  - c. Verify that retaining ring is seated in groove.
3. Install pushrod/dust boot (9). Verify that dust boot is secure in groove of piston bore.

4. 

*NOTE*

*Anti-bubble button (14) is a friction fit. Install with convex side up (see inset).*

Install anti-bubble button (14).

5. 

*NOTE*

*Baffle (15) is used only for painted front master cylinders.*

Loosely install cover (3), baffle (15) and gasket (4).

6. Install lever, pivot pin (6) and new retaining ring (8).

**COMPLETE** \_\_\_\_\_

1. Fill and bleed front brake system. See BLEED BRAKES (Page 3-60).
2. **FLHRXS:** Install mirror and turn signal lamp. See MIRRORS (Page 3-132).

## PREPARE

2.

### NOTE

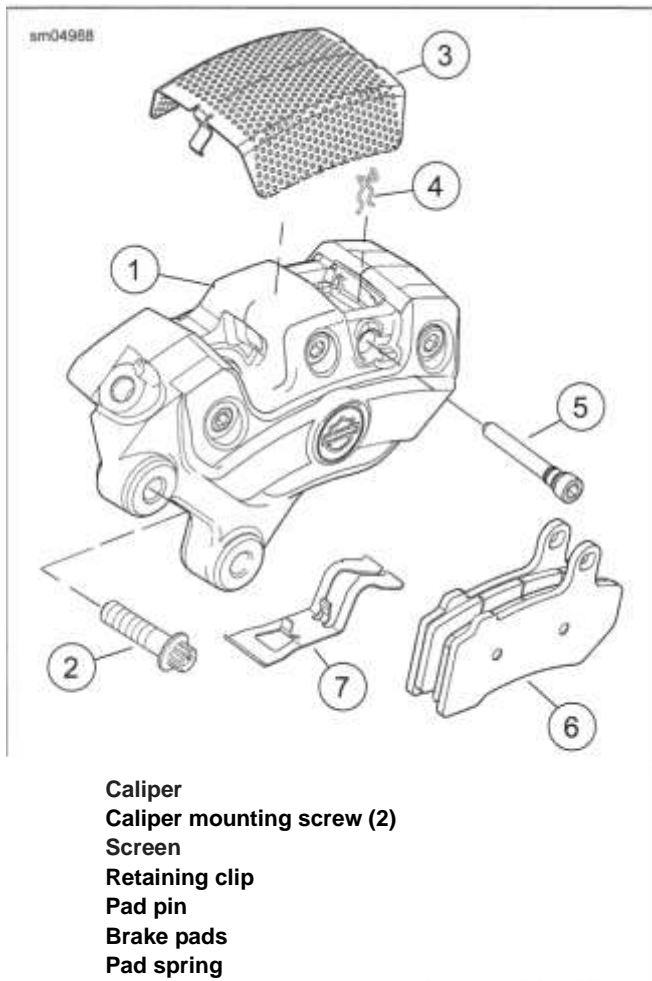
If DOT 4 brake fluid contacts painted surfaces, IMMEDIATELY flush area with clear water.

If only replacing brake pads, see INSPECT BRAKES (Page 2-19)

1. Remove banjo bleeder bolt.
2. Discard sealing washers.

## REMOVE

1. See Figure 3-44. Remove caliper mounting screws (2).
2. Remove caliper (1) from brake disc.



Caliper  
Caliper mounting screw (2)  
Screen  
Retaining clip  
Pad pin  
Brake pads  
Pad spring

Figure 3-44. Front Brake Caliper Assembly

## INSTALL

| FASTENER                     | TORQUE VALUE               |
|------------------------------|----------------------------|
| Front caliper mounting screw | 28-38 ft-lbs 1 38-51.5 N-m |

1. Assemble caliper. See INSPECT BRAKES (Page 2-19).

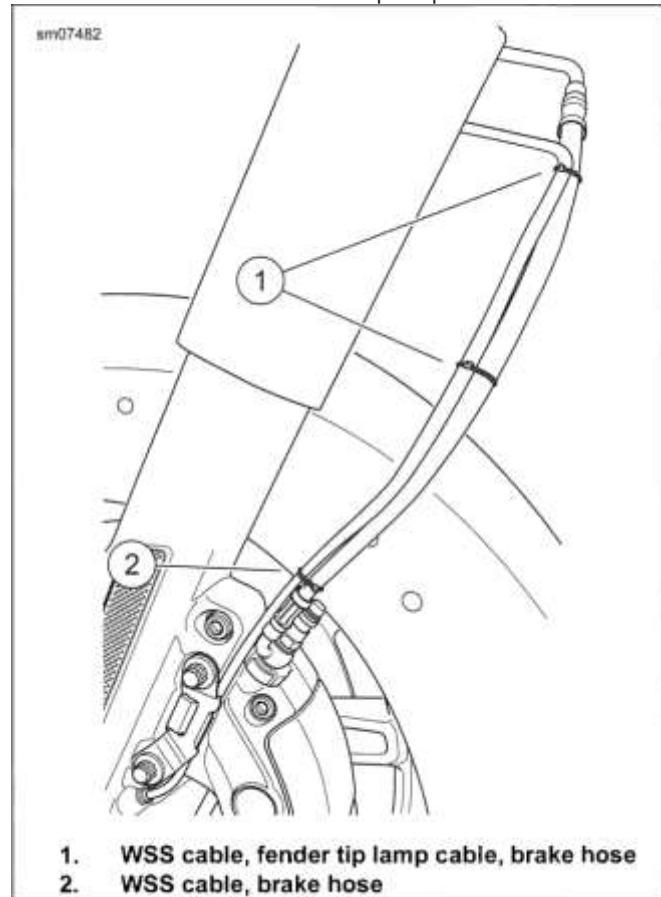
Install caliper.

- a. **ABS models:** Install WSS cable clip and bracket when installing left caliper.
- b. Install caliper with screws (2). Tighten.

Torque: 28-38 ft-lbs (38-51.5 N-m) *Front caliper mounting screw*

### 3. ABS models:

- a. Verify that WSS cable is secure in clip.
- b. See Figure 3-45. Install new cable straps (1, 2) to secure WSS and fender tip lamp cables.



1. WSS cable, fender tip lamp cable, brake hose  
2. WSS cable, brake hose

Figure 3-45. Secure Cables and Brake Hose

## COMPLETE

1. Install brake line, banjo bleeder bolt and new sealing

| FASTENER                 | TORQUE VALUE |           |
|--------------------------|--------------|-----------|
| Front caliper banjo bolt | 17-19 ft-lbs | 23-26 N-m |

washers to caliper. Tighten.

## FRONT BRAKE CALIPER

3.14

Torque: 17-19 ft-lbs (23-26 N-m) *Front caliper banjo bolt*

2. Install bleeder screw if removed.

- a. If present, discard O-ring from bleeder screw groove or bore in banjo bleeder bolt.
- b. Install bleeder screw finger-tight.

## PREPARE

### NOTE

If DOT 4 brake fluid contacts painted surfaces, IMMEDIATELY flush area with clear water.

### NOTICE

Do not allow dirt or debris to enter the master cylinder reservoir. Dirt or debris in the reservoir can cause improper operation and equipment damage. (00205c)

1. Remove main fuse. FUSES AND RELAYS (Page 8-6).
2. Stand motorcycle upright (not leaning on jiffy stand) on a level surface.
3. Remove right side rider footboard. See RIDER FOOTRESTS (Page 3-142).
4. Drain brake fluid.
  - a. Remove reservoir cover.
  - b. Remove banjo bolt from master cylinder.
  - c. Discard sealing washers.
  - d. Allow fluid to drain into container.
  - e. Wrap banjo fitting with piece of shop towel to absorb any loss of brake fluid.

## REMOVE

1. Remove master cylinder and pedal assembly.
  - a. Remove screws securing master cylinder.
  - b. Remove locknut and flat washer securing brake pedal.
  - c. Pull brake pedal/master cylinder assembly from pedal shaft.
  - d. Discard O-rings from each side of brake pedal shaft bore.
2. See Figure 3-46. Disassemble master cylinder from brake pedal.
  - a. Remove cotter pin (4) and flat washer (5) from clevis pin.
  - b. Remove clevis pin (3).
  - c. Separate master cylinder assembly from brake pedal.

## INSTALL

- a. Install master cylinder assembly onto brake pedal flange.
- b. Install clevis pin (3) from outboard side.

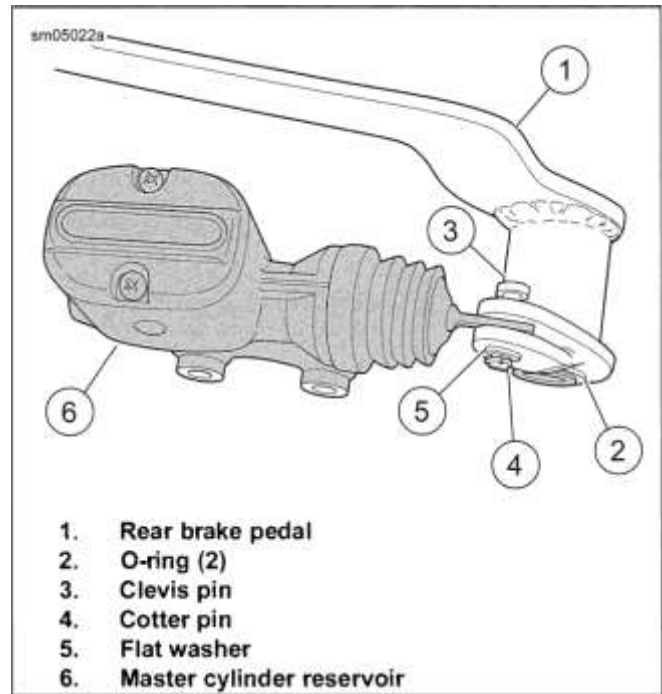


Figure 3-46. Rear Master Cylinder/Brake Pedal Assembly

1. Rear brake pedal
2. O-ring (2)
3. Clevis pin
4. Cotter pin
5. Flat washer
6. Master cylinder reservoir

- c. Install flat washer (5) and cotter pin (4) on clevis pin.

| FASTENER                        | TORQUE VALUE     |               |
|---------------------------------|------------------|---------------|
| Brake pedal shaft locknut       | 180--240 in-lbs  | 20.3-27.1 N-m |
| Master cylinder screws          | 126---150 in-lbs | 14.2-17 N-m   |
| Rear master cylinder banjo bolt | 17-19 ft-lbs     | 23-25.8 N-m   |

1. See Figure 3-47. Assemble master cylinder to brake pedal.

2. Install brake pedal master cylinder assembly.
  - a. Apply a light coat of WHEEL BEARING GREASE to brake pedal shaft and bore.
  - b. Install new O-ring (2) on each side of bore.
  - c. Install brake pedal/master cylinder assembly on pedal shaft.
  - d. Install flat washer and new locknut.
  - e. Install screws securing master cylinder. Tighten.
 

Torque: 126-150 in-lbs (14.2-17 N-m) *Master cylinder screws*
  - f. Tighten brake pedal shaft locknut.
 

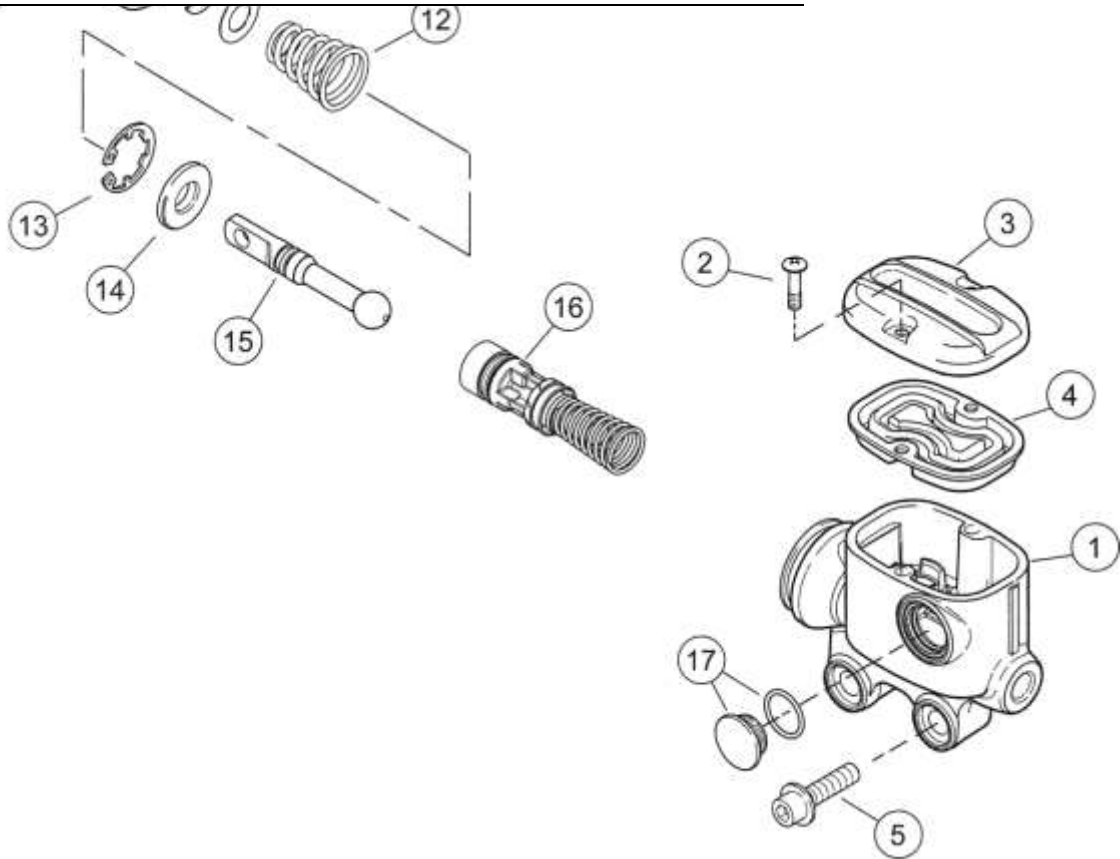
Torque: 180-240 in-lbs (20.3-27.1 N-m) *Brake pedal shaft locknut*

3. Install brake line, banjo bolt and new sealing washers. Tighten.

Torque: 17-19 ft-lbs (23-25.8 N-m) *Rear master cylinder banjo bolt*

sm05021c

- |   |  |
|---|--|
| <ol style="list-style-type: none"> <li>1. Master cylinder reservoir</li> <li>2. Cover screw (2)</li> <li>3. Cover</li> <li>4. Gasket</li> <li>5. Screw (2)</li> <li>6. Cotter pin</li> <li>7. Flat washer</li> <li>8. Clevis pin</li> <li>9. Dust boot</li> </ol> | <ol style="list-style-type: none"> <li>10. E-clip</li> <li>11. Flat washer</li> <li>12. Pedal return spring</li> <li>13. Retaining ring</li> <li>14. Special washer</li> <li>15. Pushrod</li> <li>16. Piston assembly</li> <li>17. Sight glass/O-ring</li> </ol> |
|---|--|



**Figure 3-47. Rear Brake Master Cylinder Assembly**

**DISASSEMBLE**

4. Push and hold end of piston. Remove retaining ring (13).

*NOTE*

*Do not scratch or nick banjo sealing surface during handling.*

5. Remove pushrod (15) and special washer (14).
6. Pull piston assembly from piston bore.

1. See Figure 3-47. Remove dust boot (9).
2. Push and hold flat washer (11). Remove E-clip (10) from pushrod. Carefully release spring tension.
3. Remove flat washer (11) and pedal return spring (12).



## CLEAN AND INSPECT

### **A WARNING**

**Use denatured alcohol to clean brake system components. Do not use mineral-based solvents (such as gasoline or paint thinner), which will deteriorate rubber parts even after assembly. Deterioration of these components can cause brake failure, which could result in death or serious injury. (00291 a)**

- Even residual mineral-based oils and grease can deteriorate rubber brake components.
  - Wash hands before handling brake components.
  - Never use oily rags to wipe brake components.
1. Clean all parts thoroughly.
  2. Verify that reservoir is free of dust, dirt or residue.
  3. Using a clean air supply, clear piston bore, reservoir and drilled passages. Do not use a wire or similar instrument.
  4. Inspect parts for wear or damage.
    - a. Inspect banjo seating surface for scratches or nicks.
    - b. Inspect piston bore.
    - c. Inspect dust boot retaining groove.
    - d. Inspect dust boot and reservoir cover gasket.
    - e. Inspect E-clip for wear or distortion.
    - f. Inspect retaining ring groove and E-clip groove for damage.

- g. Inspect springs for stretching, distortion, kinks, cracks or fractured coils.

### **ASSEMBLE**

1. Lightly lubricate piston bore and OD of piston seals with DOT 4 BRAKE FLUID.
2. See Figure 3-47. Insert piston assembly (16) into piston bore
3. Slide special washer (14), with collar facing outer end of pushrod and new retaining ring (13) over pushrod.
4. Hold piston assembly in and install retaining ring with flat side in. Verify that retaining ring is seated in groove.
5. Seat pedal return spring (12) on retaining ring.
6. Slide flat washer (11) over pushrod.
7. Compress pedal return spring and install E-clip (10) in inboard groove of pushrod.
8. Install dust boot (9).

### **COMPLETE**

1. Fill and bleed brake system. See BLEED BRAKES (Page 3-60).
2. Install right side rider footboard. See RIDER FOOTRESTS (Page 3-142).
3. Install main fuse. See FUSES AND RELAYS (Page 8-6).

## PREPARE

**NOTE**

If DOT 4 brake fluid contacts painted surfaces, IMMEDIATELY flush area with clear water.

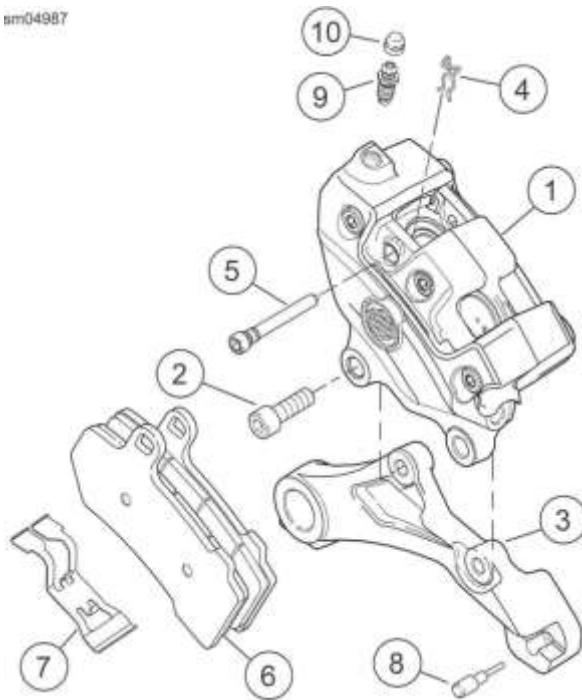
If only replacing brake pads, see INSPECT BRAKES (Page 2-19).

1. Remove right saddlebag. See SADDLEBAGS (Page 3-161).
2. Remove banjo bolt.
3. Discard sealing washers.

## REMOVE

1. See Figure 3-48. Remove screws (2).
2. Remove caliper from brake disc.
3. If necessary, remove caliper bracket (3). See REAR WHEEL (Page 3-14)

mm04987



1. Caliper
  2. Caliper bracket screw (2)
  3. Caliper bracket
  4. Retaining clip
  5. Pad pin
  6. Brake pads
  7. Pad spring
  8. Rubber bumper
  9. Bleeder screw
  10. Bleeder screw cap
- Figure 3-48. Rear Brake Caliper Assembly

## INSTALL

| FASTENER                    | TORQUE VALUE                |
|-----------------------------|-----------------------------|
| Rear caliper mounting screw | 43-48 ft-lbs 158.3-65.1 N-m |

1. See Figure 3-48. Install caliper bracket (3), if removed. See REAR WHEEL (Page 3-14).
2. Assemble caliper. See INSPECT BRAKES (Page 2-19).
3. Install caliper with screws (2). Tighten.

Torque: 43-48 ft-lbs (58.3-65.1 N-m) *Rear caliper mounting screw*

## COMPLETE

| FASTENER                | TORQUE VALUE |               |
|-------------------------|--------------|---------------|
| Rear caliper banjo bolt | 17-19 ft-lbs | 23.1-25.8 N-m |

1. Install brake line, banjo bleeder bolt and new sealing washers to caliper. Tighten.  
Torque: 17-19 ft-lbs (23.1-25.8 N-m) *Rear caliper banjo bolt*
2. Install bleeder screw if removed.
  - a. If present, discard the O-ring from the bleeder screw groove or bore in banjo bleeder bolt.
  - b. Install bleeder screw finger-tight.
3. Bleed brake system. See BLEED BRAKES (Page 3-60).
4. Install right saddlebag. See SADDLEBAGS (Page 3-161).

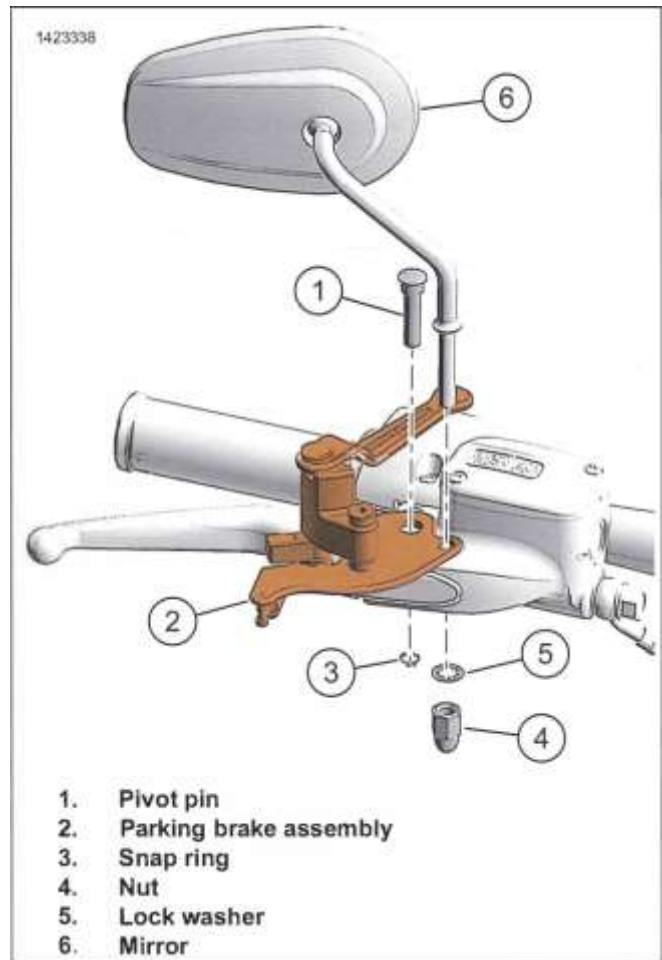


Figure 3-49. Parking Brake (Indonesia)

| FASTENER          | TORQUE VALUE |           |
|-------------------|--------------|-----------|
|                   | 10-14 ft-lbs | 14-19 N-m |
| Parking brake nut |              |           |

### REMOVE INDONESIA ONLY

#### NOTE

Make sure parking brake is disengaged.

#### With Mirror

- See Figure 3-49. Remove mirror assembly. See MIRRORS (Page 3-132).
- Remove snap ring (3).
- Remove pivot pin (1).
- Remove parking brake assembly (2).

#### Without Mirror

- See Figure 3-50. Remove nut (5).
- Remove screw (4).
- Remove snap ring (3).
- Remove pivot pin (1).
- Remove parking brake assembly (2).

### INSTALL INDONESIA ONLY

#### NOTE

System uses unique brake pivot hardware - reuse or replace as needed with correct parts designated for parking brake application.

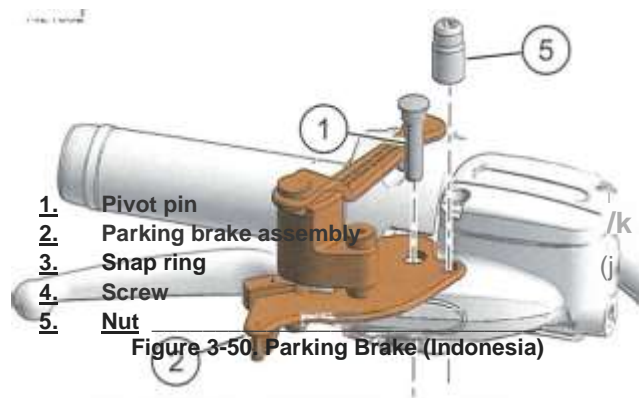
#### With Mirror

- See Figure 3-49. Install parking brake assembly.
  - Install parking brake assembly (2) above master cylinder bracket.
  - Align holes of parking brake assembly, master cylinder bracket and brake lever.
  - Install pivot pin (1).
  - Install snap ring (3).
- Align holes in parking brake assembly (2) and master cylinder bracket. Install mirror assembly (4, 5, 6). See MIRRORS (Page 3-132).

## Without Mirror

1. See Figure 3-50. Install parking brake assembly.
  - a. Install parking brake assembly (2) above the brake lever.
  - b. Align holes of parking brake assembly, master cylinder and brake lever.
  - c. Install pivot pin (1).
  - d. Install snap ring (3).
2. Align holes in parking brake assembly (2) and master cylinder bracket. Install screw (4).
3. Install nut (5). Tighten.

Torque: 10-14 ft-lbs (14-19 N-m) *Parking brake nut*



**BRAKE LINE: FRONT MASTER CYLINDER TO ABS MODULE**

| PART NUMBER                | TOOL NAME                  |               |
|----------------------------|----------------------------|---------------|
| BB200A                     | BASIC VACUUM BRAKE BLEEDER |               |
| FASTENER                   | TORQUE VALUE               |               |
| ABS module banjo bolt      | 28-30 ft-lbs               | 38-40.6 N-m   |
| Master cylinder banjo bolt | 17-19 ft-lbs               | 23.1-25.8 N-m |
| Rear battery tray screw    | 132-156 <b>in-lbs</b>      | 14.9-17.6 N-m |

**Prepare**

- Remove right saddlebag. See SADDLEBAGS (Page 3-161).
- Remove right side cover.
- Remove fuel tank. See FUEL TANK (Page 6-10).
- Remove top caddy. See TOP CADDY (Page 8-107).
- Road King models:** Remove right side headlamp nacelle. See HEADLAMP NACELLE (Page 3-87).
- Fairing models, fork-mounted:** Remove outerfairing and dash panel. See FAIRING: FORK MOUNTED (Page 3-89).
- Fairing models, frame-mounted:** Remove instrument nacelle. See FAIRING: FRAME MOUNTED (Page 3-100).

8. **NOTE**

For best results, use **BASIC VACUUM BRAKE BLEEDER (PART NUMBER: BB200A)** or equivalent to drain the brake systems.

Drain brake line.

- Remove cover from master cylinder reservoir.
- Attach vacuum brake bleeder to front caliper bleeder screw. Loosen screw 3/4 turn.
- Operate vacuum bleeder to evacuate all fluid from master cylinder and line.
- Wipe out any remaining fluid inside master cylinder reservoir with a clean, lint-free cloth.

**Remove**

- Cut cable straps to release brake line.
- See Figure 3-51. Release brake line from brake line retainer (1).
  - Release upper latch.
  - Rotate top of retainer out and lift from pocket in caddy.
  - Remove line from retainer.

**NOTE**

Loosen and tighten banjo bolts while ABS module is secured.

See Figure 3-53. Remove brake line.

- Remove retainer (5).
- See Figure 3-52. Remove alignment clip (7) from lines at ABS module.
- Loosen banjo bolt (5).
- Remove two rear battery tray screws to allow battery tray to lower.
- Remove banjo bolt (5). Discard sealing washers.
- Remove banjo bolt from master cylinder. Discard sealing washers.
- Remove brake line.

**Install**

- NOTE**  
Loosen and tighten banjo bolts while ABS module is secured.

Install brake line.

- Route brake line along right side of wire trough with rear banjo fitting near ABS module.
  - Route front of brake line forward along right side of steering head and up to master cylinder.
  - Start banjo bleeder bolt with **new** sealing washers to secure brake line to caliper.
  - Start banjo bolt with **new** sealing washers to secure brake line to ABS module port marked MF.
  - See Figure 3-52. Install alignment clip (7) onto lines at ABS module.
- Secure brake line.
    - See Figure 3-55. Secure brake line (2) to right riser with **new** cable strap (1).
  - See Figure 3-51. Secure brake line right side steering head caddy.
    - Install line in brake line retainer (1).
    - Insert retainer into pocket in caddy.
    - Rotate top of retainer in until latched.

**NOTE**

See Figure 3-53. The order in which lines are arranged is important. Arrange as the insets show.

4. Secure brake lines to wire trough including central anchor block.
  - a. Secure lines at rear within retainer (4) and under the tab.
  - b. Secure lines in retaining features (6) at front of wire trough.
  - c. See Figure 3-54. Install retainer (3).
  - d. Install **new** cable strap (4).
5. Tighten master cylinder banjo bolt.  
Torque: 17-19 ft-lbs (23.1-25.8 N-m) *Master cylinder banjo bolt*
6. Install rear battery tray screws. Tighten.  
Torque: 132-156 **in-lbs** (14.9-17.6 N-m) *Rear battery tray screw*
7. Tighten ABS module banjo bolt.  
Torque: 28-30 ft-lbs (38-40.6 N-m) *ABS module banjo bolt*

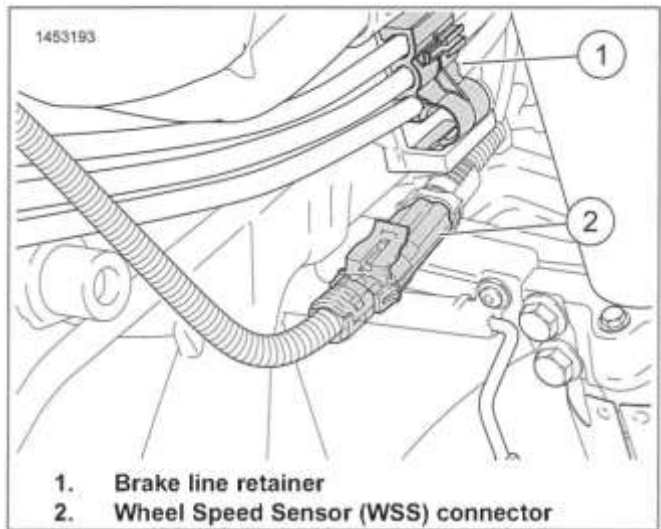
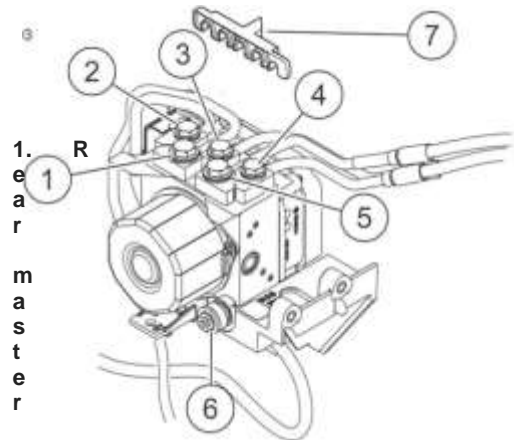
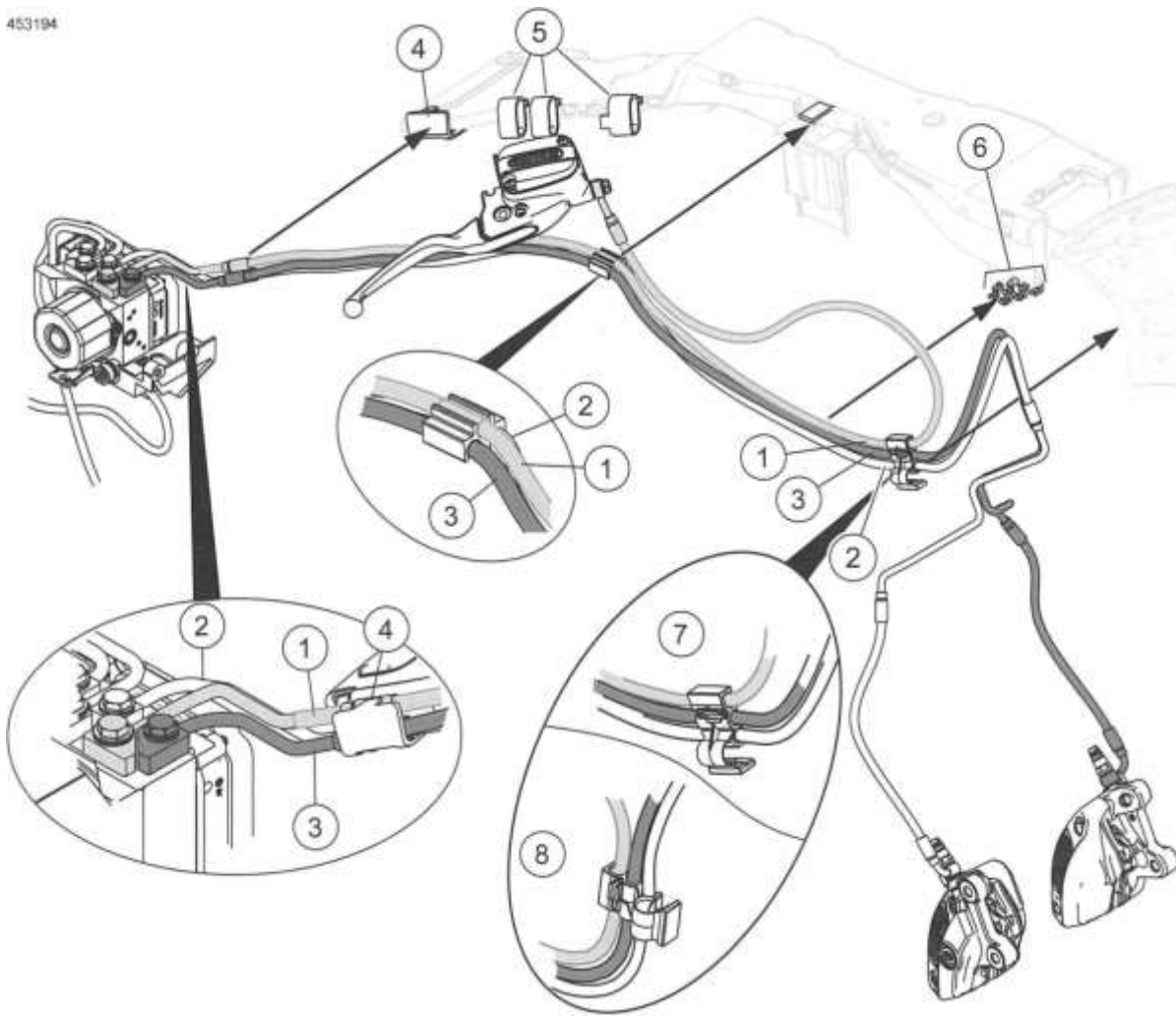


Figure 3-51. Steering Head Caddy (right side shown)



1. Rear master cylinder, 12 mm
2. ABS module to rear caliper, 10 mm
3. ABS module to front-right caliper, 10 mm
4. ABS module to front-left caliper, 10 mm
5. Front master cylinder, 12 mm
6. Mount locknut (2)
7. Alignment clip

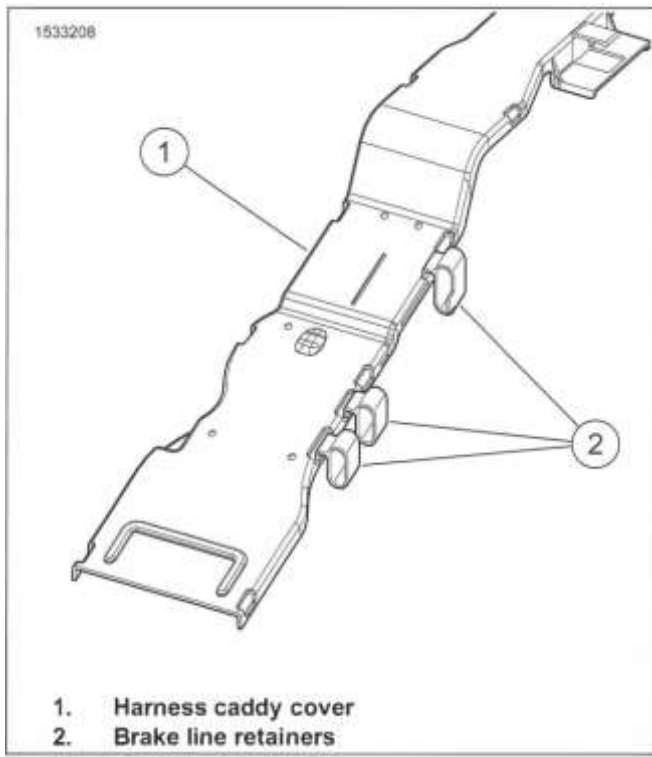
Figure 3-52. ABS Module Connections



- |  |   |
|--|---|
| 1. Front master cylinder to ABS module | 5. Brake line retainer                    |
| 2. ABS module to front right caliper   | 6. Retaining features                     |
| 3. ABS module to front left caliper    | 7. Fork mounted fairing line orientation  |
| 4. Retainer with tab                   | 8. Frame mounted fairing line orientation |

Figure 3-53. Front ABS Brake Line Routing

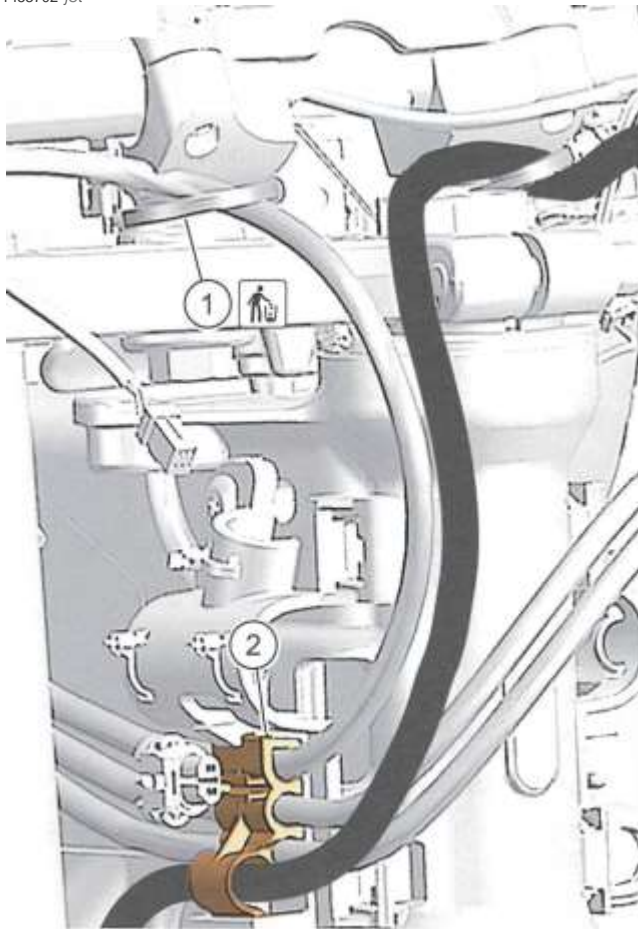




1. Harness caddy cover
2. Brake line retainers

Figure 3-54. Brake Line Retainer

\*1453702 j/LA



1. Brake line to right riser
2. Brake line retainer

Figure 3-55. Capture Brake Fluid Lines (Typical)

## Complete

### A WARNING

When any hydraulic brake component, line or connection is loosened or replaced on an ABS motorcycle, Digital Technician II must be used during the brake bleeding procedure to verify all air is removed from the system. Failure to properly bleed the brake system could adversely affect braking, which could result in death or serious injury. (00585c)

1. Bleed brake system. See BLEED BRAKES (Page 3-60).
2. **Road King models:** Install right side headlamp nacelle. See HEADLAMP NACELLE (Page 3-87).
3. **Fairing models, fork-mounted:** Install outer fairing and dash panel. See FAIRING: FORK MOUNTED (Page 3-89).
4. **Fairing models, frame-mounted:** See FAIRING: FRAME MOUNTED (Page 3-100).
5. Install top caddy. See TOP CADDY (Page 8-107).
6. Install fuel tank. See FUEL TANK (Page 6-10).
7. Install right side cover.
8. Install right saddlebag. See SADDLEBAGS (Page 3-161).

## BRAKE LINE: FRONT CALIPER TO ABS MODULE

| PART NUMBER | TOOL NAME                  |
|-------------|----------------------------|
| BB200A      | BASIC VACUUM BRAKE BLEEDER |

| FASTENER                 | TORQUE VALUE   |               |
|--------------------------|----------------|---------------|
| ABS module banjo bolt    | 17-19 ft-lbs   | 23.1-25.8 N-m |
| Front caliper banjo bolt | 17-19 ft-lbs   | 23.1-25.8 N-m |
| Rear battery tray screw  | 132-156 in-lbs | 14.9-17.6 N-m |

## Prepare

### NOTE

This system has separate brake lines to each front caliper. Replacement is similar for both.

1. Remove right saddlebag. See SADDLEBAGS (Page 3-161).
2. Remove right side cover.
3. Remove fuel tank. See FUEL TANK (Page 6-10).
4. Remove top caddy. See TOP CADDY (Page 8-107).
5. **Road King models:** Remove headlamp nacelle. See HEADLAMP NACELLE (Page 3-87).
6. **Fairing models, fork-mounted:** Remove outer fairing and dash panel. See FAIRING: FORK MOUNTED (Page 3-89).

7. **Fairing models, frame-mounted:FAIRING: FRAME MOUNTED** (Page 3-100).

8. **NOTE**

For best results, use **BASIC VACUUM BRAKE BLEEDER (PART NUMBER: BB200A)** or equivalent to drain the brake systems.

Drain front brake lines.

- f. Remove brake line.
- a. Remove master cylinder reservoir cover.
- b. Attach vacuum brake bleeder to caliper bleeder screw. Loosen screw 3/4 turn.
- c. Operate vacuum bleeder to evacuate all fluid from master cylinder and line.
- d. Wipe out any remaining fluid inside master cylinder reservoir with a clean, lint-free cloth.
- a. Route brake line rearward along right side of steering

**Remove**

1. See Figure 3-51. Release brake line from brake line retainer (1 ).
  - a. Release upper latch.
  - b. Rotate top of retainer out and lift from pocket in caddy.
  - c. Remove line from retainer.
2. See Figure 3-53. Release brake line.
  - a. Remove retainer (5). Release brake line from wire trough.
  - b. Release brake line from retainer (2) on lower fork bracket.
  - c. **Right line:** Release brake line from three conduit clips near front of steering head.
  - d. **Left line:** Cut three cable straps securing front wheel speed sensor cable and front fender tip lamp wires (if equipped) to left caliper brake hose.
  - e. See Figure 3-52. Install alignment clip (7) onto lines at

3.

**NOTE**

Loosen and tighten banjo bolts while ABS module is secured.

See Figure 3-52. Remove brake line.

- a. Loosen banjo bolt (3 or 4).
  - b. Remove alignment clip (7) from lines at ABS module.
  - c. Remove two rear battery tray screws to allow battery tray to lower.
  - d. Remove banjo bolt securing brake line to ABS module. Discard sealing washers.
  - e. Remove banjo bleeder bolt securing brake line to caliper. Discard sealing washers.
4. Install rear battery tray screws. Tighten.

**Install**

**NOTE**

Loosen and tighten banjo bolts while ABS module is secured.

1. Install brake line.
  - b. Start banjo bleeder bolt with new sealing washers to secure brake line to caliper.
  - c. Secure brake line in lower fork bracket retainer. Latch retainer closed. Install cable strap.
  - d. Start banjo bolt with new sealing washers to secure brake line to ABS module.

ABS module.

**NOTE**

See Figure 3-53. The order in which lines are arranged is important. Arrange as the insets show.

2. Secure brake lines to wire trough including central anchor block.
  - a. Secure lines at rear within retainer (4) and under the tab.
  - b. Secure lines in retaining features (6) at front of wire trough.
  - c. Install retainer (5).
3. See Figure 3-51. Secure brake line to right side steering head caddy.
  - a. Install line in retainer (1).
  - b. Insert retainer into pocket in caddy.
  - c. Rotate top of retainer in until latched.

Torque: 132-156 **in-lbs** (14.9-17.6 N-m) *Rear battery tray screw*

5. Tighten ABS module banjo bolt.  
Torque: 17-19 ft-lbs (23.1-25.8 N-m) *ABS module banjo bolt*
6. Tighten caliper banjo bleeder bolt.  
Torque: 17-19 ft-lbs (23.1-25.8 N-m) *Front caliper banjo bolt*
7. **Left line:** Secure the WSS cable and fender tip lamp wires using three new cable straps:
  - a. On the brake hose lower crimp capturing cable and brake hose.

| PART NUMBER | CONSUMABLE  |
|-------------|---|
| 99642-97    | LOCTITE 243 MEDIUM STRENGTH<br>THREADLOCKER AND SEALANT<br>(BLUE) |

| PART NUMBER | TOOL NAME                  |
|-------------|----------------------------|
| BB200A      | BASIC VACUUM BRAKE BLEEDER |

| FASTENER                           | TORQUE VALUE  |             |
|------------------------------------|---------------|-------------|
| Banjo bolt to ABS module, 12 mm    | 28-30 ft-lbs  | 38-40.6 N-m |
| Banjo bolt to rear master cylinder | 17 ft-lbs     | 23.1 N-m    |
| Brake line, rear, P-clamp screw    | 80-100 in-lbs | 9-11.3 N-m  |
| Enginemount end cap screws, front  | 42-48 ft-lbs  | 56.9-65 N-m |
| Hydraulic line multi-clamp screw   | 10-15 in-lbs  | 1.1-1.7 N-m |

b. Midway between the upper and lower brake hose crimps capturing cable, brake hose and front fender tip lamp wires, if equipped.

c. On upper crimp capturing sensor cable, brake hose and front fender tip lamp wires, if equipped.

8. Right line: Secure WSS cable to line with three conduit clips near front of steering head.

## Complete

### A WARNING

When any hydraulic brake component, line or connection is loosened or replaced on an ABS motorcycle, Digital Technician II must be used during the brake bleeding procedure to verify all air is removed from the system. Failure to properly bleed the brake system could adversely affect braking, which could result in death or serious injury. (00585c)

1. Bleed brake system. See BLEED BRAKES (Page 3-60).
2. Road King models: Install headlamp nacelle. See HEADLAMP NACELLE (Page 3-87).
3. Fairing models, fork-mounted: Install outer fairing and dash panel. See FAIRING: FORK MOUNTED (Page 3-89).
4. Fairing models, frame-mounted: Install outer fairing and dash panel. See FAIRING: FRAME MOUNTED (Page 3-100).
5. Install top caddy. See TOP CADDY (Page 8-107).
6. Install fuel tank. See FUEL TANK (Page 6-10).
7. Install right side cover.
8. Install right saddlebag. See SADDLEBAGS (Page 3-161).

## **BRAKE LINE: REAR MASTER CYLINDER TO ABS MODULE**

## Prepare

1. Remove right saddlebag. See SADDLEBAGS (Page 3-161).
2. Remove right side cover.
3. Remove right passenger footboard/footpeg. See PASSENGER FOOTRESTS (Page 3-144).
4. Stand motorcycle upright (not leaning on jiffy stand) on a level surface.

### NOTE

- Clean master cylinder reservoir cover before removal.
- For best results, use BASIC VACUUM BRAKE BLEEDER (PART NUMBER: BB200A) or equivalent to drain the brake systems.

Drain rear brake line.

- a. Remove master cylinder reservoir cover.
- b. Attach vacuum brake bleeder to rear caliper bleeder screw. Loosen screw 3/4 turn.
- c. Operate vacuum bleeder to evacuate all fluid from master cylinder and line.
- d. Wipe out any remaining fluid inside master cylinder reservoir with a clean, lint-free cloth.

## Remove

1. Remove right footboard/rear brake master cylinder.
  - a. See Figure 3-57. Remove banjo bolt (13) from master cylinder reservoir. Discard sealing washers.
  - b. Support front of engine.
  - c. Remove three screws securing front right engine mount end cap.
  - d. Pull off end cap mount with footboard, master cylinder and brake pedal attached.
2. See Figure 3-56. Remove brake line from multi-clamp.
  - a. Remove HO2 sensor wires from clip on clamp.
  - b. Remove screw (4).
  - c. Open clamp to release brake line.

### NOTE

Loosen and tighten banjo bolts while ABS module is secured.

Remove brake line.

- a. See Figure 3-58. Remove banjo bolt (1) securing brake line to ABS module. Discard sealing washers.
- b. Remove alignment clip (7) from lines at ABS module.
- c. See Figure 3-57. Free brake line from electrical harness conduit clips (6).
- d. Remove terminals from rear stop lamp switch (11 ).
- e. Remove fastener (5) securing P-clamp (4).
- f. Release line from retainers (14) securing line to frame.
- g. Cut cable straps as needed. Record their locations for assembly.
- h. Remove brake line.

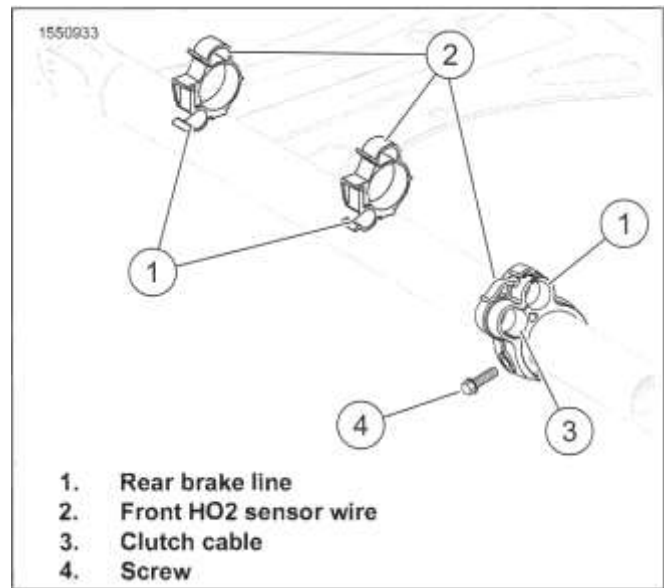
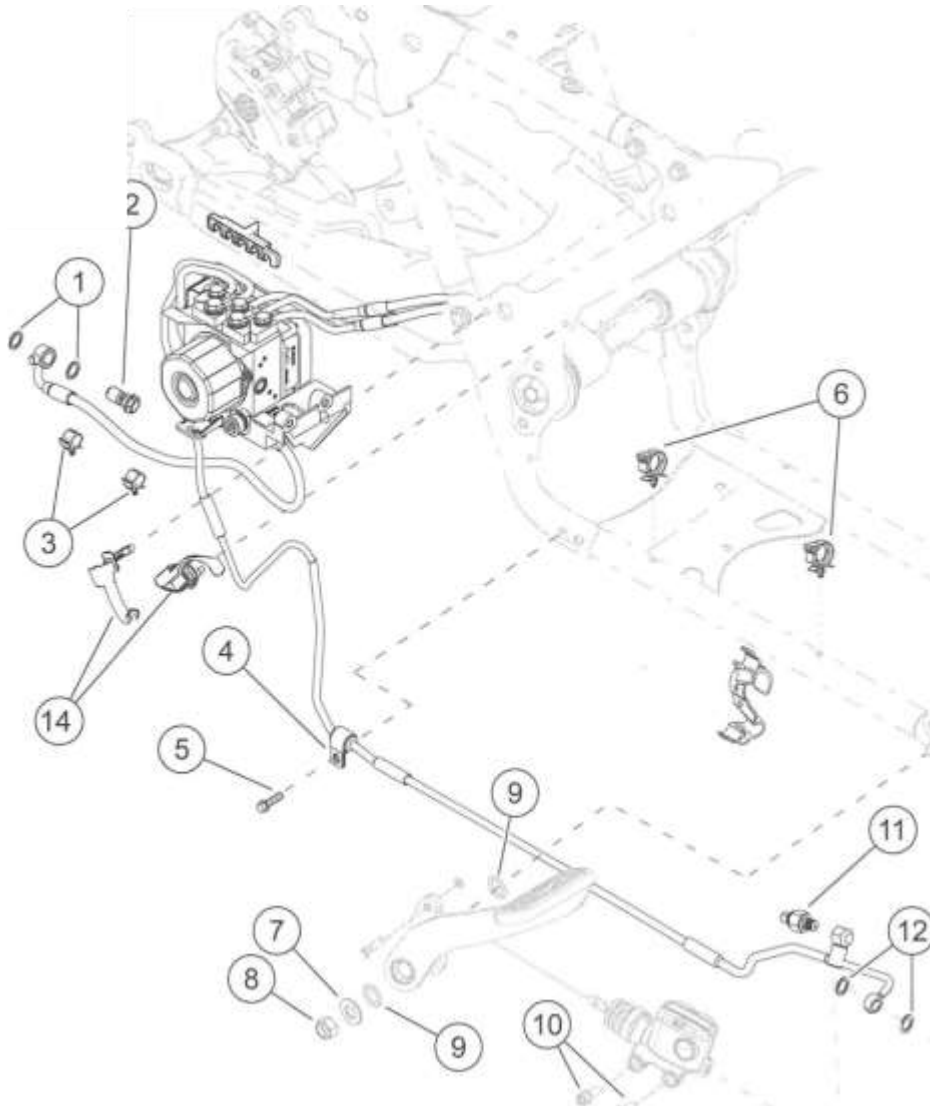


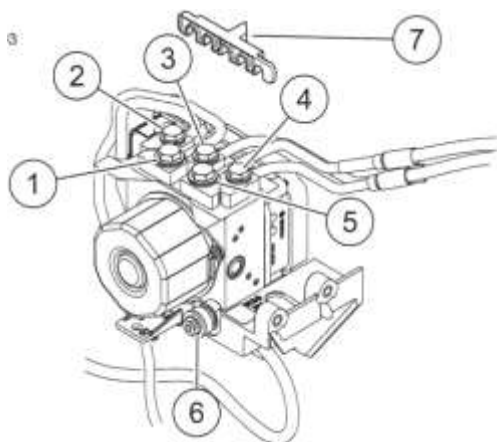
Figure 3-56. Lower Frame Rail Line and Harness Retainers



-CI

- |  |                           |
|--|---------------------------|
| 2. Banjo bolt                          | 9. O-ring                 |
| 3. Brake hose clips                    | 10. Fastener              |
| 4. P-clamp                             | 11. Rear stop lamp switch |
| 5. Fastener                            | 12. Sealing washers       |
| 6. Electrical harness/brake line clips | 13. Banjo bolt            |
| 7. Flat washer                         | 14. Brake line retainers  |

Figure 3-57. Rear ABS Brake Line Assembly



1. Rear master cylinder, 12 mm
  2. ABS module to rear caliper, 10 mm
  3. ABS module to front-right caliper, 10 mm
  4. ABS module to front-left caliper, 10 mm
  5. Front master cylinder, 12 mm
  6. Mount locknut (2)
  7. Alignment clip
- Figure 3-58. ABS Module Connections**

## Install

1. **NOTE**  
*Loosen and tighten banjo bolts while ABS module is secured.*

If installing new rear stop lamp switch, apply LOCTITE 565 THREAD SEALANT. Install switch into rear brake line. Tighten.

2. Install brake line.
  - a. Place rear brake line into approximate position. Route over passenger footboard boss and upward to ABS module.
  - b. See Figure 3-58. Install alignment clip (7) onto lines at ABS module.
  - c. Install line, banjo bolt (1) and new sealing washers to ABS module. Tighten.  
Torque: 28-30 ft-lbs (38-40.6 N-m) *Banjo bolt to ABS module, 12 mm*
  - d. See Figure 3-57. Secure P-clamp (4) with screw (5). Tighten.  
Torque: 80-100 **in-lbs** (9-11.3 N-m) *Brake line, rear, P-clamp screw*
  - e. Secure retaining clips (14).
  - f. Install cable new straps in previously recorded positions.
3. Secure brake line in clamps.
  - a. See Figure 3-56. Capture rear brake line in lower clip of electrical harness retainers and upper passage of multi-clamp.

- b. Close multi-clamp to secure brake line and clutch line.
- c. Apply threadlocker to the threads of used screw (4).  
LOCTITE 243 MEDIUM STRENGTH  
THREADLOCKER AND SEALANT (BLUE) (99642-97)
- d. Install screw (4). Tighten.  
Torque: 10-15 **in-lbs** (1.1-1.7 N-m) *Hydraulic line multi-clamp screw*
- e. Install front HO2 sensor wire in clip on clamp.

4. Install right side front engine mount cap with rider footboard and master cylinder attached:
  - a. Connect terminals onto rear stop lamp switch (11).

### NOTE

*Confirm oil switch/sender wires are inboard of rubber mount.*

- b. Install engine mount end cap. Tighten.  
Torque: 42-48 ft-lbs (56.9-65 N-m) *Enginemount end cap screws, front*
- c. Remove support under front of engine.
- d. Install cable **new** straps in previously recorded positions.
- e. Install brake line, banjo bolt (13) and **new** sealing washers (12) to master cylinder. Tighten.  
Torque: 17 ft-lbs (23.1 N-m) *Banjo bolt to rear master cylinder*

## Complete

### A WARNING

**When any hydraulic brake component, line or connection is loosened or replaced on an ABS motorcycle, Digital Technician II must be used during the brake bleeding procedure to verify all air is removed from the system. Failure to properly bleed the brake system could adversely affect braking, which could result in death or serious injury. (00585c)**

1. Bleed brake system. See BLEED BRAKES (Page 3-60).
2. Install right passenger footboard/footpeg. See PASSENGER FOOTRESTS (Page 3-144).
3. Install right side cover.
4. Install right saddlebag. See SADDLEBAGS (Page 3-161).

## BRAKE LINE: REAR CALIPER TO ABS MODULE

| PART NUMBER | TOOL NAME                  |
|-------------|----------------------------|
| BB200A      | BASIC VACUUM BRAKE BLEEDER |

| FASTENER                     | TORQUE VALUE     |               |
|------------------------------|------------------|---------------|
| Banjo bolt to ABS module, mm | 17.0--19.0ft-lbs | 23.1-25.8 N-m |
| Banjo bolt to rear caliper   | 17.0-19.0ft-lbs  | 23.1-25.8 N-m |

## Prepare

1. Remove right saddlebag. See SADDLEBAGS (Page 3-161).
2. Remove right side cover.
3. 

*NOTE*

*For best results, use BASIC VACUUM BRAKE BLEEDER (PART NUMBER: BB200A) or equivalent to drain the brake systems.*

Drain rear brake line.

- a. Remove master cylinder reservoir cover.
- b. Attach vacuum brake bleeder to rear caliper bleeder screw. Loosen screw 3/4 turn.
- c. Operate vacuum bleeder to evacuate all fluid from master cylinder and line.
- d. Wipe out any remaining fluid inside master cylinder reservoir with a clean, lint-free cloth.

## Remove

1. See Figure 3-57. Remove brake line.
  - a. Free rear brake hose from brake hose clips (3) on rear fork.
  - b. Remove conduit clip securing rear wheel speed sensor cable to brake hose.
  - c. See Figure 3-58. Remove banjo bolt (2) to release brake line from ABS module. Discard sealing washers.

- d. Remove alignment clip (7) from lines at ABS module.
- e. Remove banjo bolt (2) from rear brake caliper. Discard sealing washers (1).
- f. Release brake line from retainer on right caddy.
- g. Remove brake line.

## Install

1. Install brake line.
  - a. Place brake line in approximate position. Secure to retainer on right caddy.
  - b. See Figure 3-58. Install alignment clip (7) onto lines at ABS module.
  - c. See Figure 3-57. Install line, banjo bolt (2) and new sealing washers to ABS module. Tighten.  
Torque: 17.0-19.0 ft-lbs (23.1-25.8 N-m) *Banjo bolt to ABS module, mm*
  - d. Install line, banjo bolt (2) and new sealing washers to rear caliper. Tighten.  
Torque: 17.0-19.0 ft-lbs (23.1-25.8 N-m) *Banjo bolt to rear caliper*
  - e. Capture brake hose and wheel speed sensor cable in two brake hose clips (3) on rear fork.

## Complete

1. Bleed brake system. See BLEED BRAKES (Page 3-60).
2. Install right side cover.
3. Install right side saddlebag. See SADDLEBAGS (Page 3-161).



**GENERAL**

The ABS module consists of the HCU (Hydraulic control unit) and the ECU (Electronic control unit). The two are not serviced separately.

**Reflex™ Linked Brakes With ABS Operation**

This ABS braking system is an electronically linked brake system. Front and rear brakes are dynamically linked through the electronic ABS module. "Linked" means that both front and rear brakes are applied at the same time. Electronic linking provides maximum braking for all riders while allowing the more experienced rider flexibility. Braking is more responsive and allows more balanced braking under a wider range of conditions.

- Reflex™ Linked Brakes is designed and tuned to provide a seamless and predictable braking response.
- Linking is electronically controlled to achieve an optimized brake balance based on the amount of brake applied and vehicle speed. The amount of linking is dynamically adjusted to provide maximum benefit in heavier braking and is reduced or eliminated for light braking and low speed.
- Linking can occur in any braking situation above 32--40 km/h (20-25 mph) whether only the front brake, rear brake or both brakes are applied. When applying both brakes, the rider may detect slight feedback in the front brake lever or rear brake pedal while the dynamic balancing occurs.
- The amount of linking is programmed to provide a good balance of stopping and rider feel.
- Front and rear brake systems are still hydraulically independent.
- If an ABS event occurs, the ABS unit will pulse the brakes to help prevent wheel lockup.

**PREPARE**

| PART NUMBER | TOOL NAME                  |
|-------------|----------------------------|
| BB200A      | BASIC VACUUM BRAKE BLEEDER |

1. Remove right saddlebag. See SADDLEBAGS (Page 3-161) .
2. Remove right side cover.

3. **NOTE**

*For best results, use the BASIC VACUUM BRAKE BLEEDER (PART NUMBER: BB200A) or equivalent tool to drain the brake systems.*

Drain fluid from system.

- a. Remove both master cylinder reservoir covers.
- b. Attach vacuum brake bleeder to a caliper bleeder screw. Loosen screw 3/4 turn.
- c. Operate vacuum bleeder to evacuate all fluid from master cylinder and line. Repeat with remaining calipers.

- d. Wipe out any remaining fluid inside master cylinder reservoir with a clean, lint-free cloth.

**REMOVE**

**NOTICE**

This device is sensitive to electrostatic discharge (ESD). To prevent damage to the device, always touch the motorcycle frame or a grounded surface before handling. (00588c)

**NOTE**

*Loosen and tighten banjo bolts while ABS module is secured.*

1. Disconnect ABS module.
  - a. Disconnect ABS module electrical connector.
  - b. Loosen five banjo bolts (metric). Do not remove.
  - c. See Figure 3-59. Remove alignment clip (7) from lines at ABS module.
  - d. Remove two rear battery tray screws to allow battery tray to lower.
  - e. Remove five banjo bolts to release brake lines from ABS module. Discard sealing washers.

**NOTE**

*Pry between the bottom of the ABS module and the right caddy to release stud on bottom of module from grommet.*

2. Remove module.
  - a. See Figure 3-59. Loosen two locknuts (6) at rubber mounts.
  - b. Separate ABS module from caddy.
3. Inspect rubber mounts and grommet for damage or deterioration. Replace parts if necessary.

**INSTALL**

| PART NUMBER | TOOL NAME             |
|-------------|-----------------------|
| HD-48650    | DIGITAL TECHNICIAN II |

| FASTENER                        | TORQUE VALUE   |               |
|---------------------------------|----------------|---------------|
| ABS module locknuts             | 53-89 in-lbs   | 6-10 N-m      |
| Banjo bolt to ABS module, 10 mm | 17-19 ft-lbs   | 23.1-25.8 N-m |
| Banjo bolt to ABS module, 12 mm | 28-30 ft-lbs   | 38--40.6 N-m  |
| Battery tray screws             | 132-156 in-lbs | 14.9-17.6 N-m |

## NOTICE

This device is sensitive to electrostatic discharge (ESD). To prevent damage to the device, always touch the motorcycle frame or a grounded surface before handling. (00588c)

### 1. Install ABS module.

- a. Apply glass cleaner to ease installation of stud into grommet. Install ABS module on right caddy.
- b. See Figure 3-59. Tighten locknuts (6).

Torque: 53-89 in-lbs (6-10 N-m) *ABS module locknuts*

#### NOTE

*The order in which lines are arranged is important. Arrange as the insets show in Figure 3-53.*

### 2. Connect lines.

- a. Route rear caliper line under rear master cylinder line.
- b. Install banjo fittings to their respective ports with banjo bolts and new sealing washers. Do not tighten.
- c. Install alignment clip (7) onto lines at ABS module.
- d. Install rear battery tray screws. Tighten.

Torque: 132-156 in-lbs (14.9-17.6 N-m) *Battery tray screws*

### 3. Tighten banjo bolts.

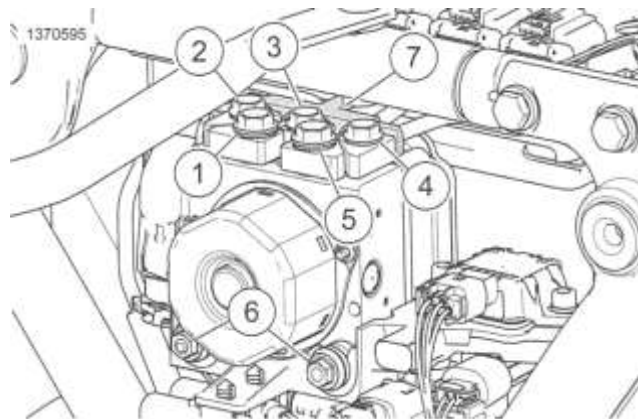
Torque: 17-19 ft-lbs (23.1-25.8 N-m) *Banjo bolt to ABS module, 10 mm*

Torque: 28-30 ft-lbs (38-40.6 N-m) *Banjo bolt to ABS module, 12 mm*

### 4. Connect ABS module electrical connector.

### 5. If installing a new ABS module, it must be set up using:

Special Tool: DIGITAL TECHNICIAN II (HD-48650)



1. Rear master cylinder, 12 mm
2. ABS module to rear caliper, 10 mm
3. ABS module to front-right caliper, 10 mm
4. ABS module to front-left caliper, 10 mm
5. Front master cylinder, 12 mm
6. Mount locknut (2)
7. Alignment clip

Figure 3-59. ABS Module Connections

## COMPLETE

### A WARNING

When any hydraulic brake component, line or connection is loosened or replaced on an ABS motorcycle, Digital Technician II must be used during the brake bleeding procedure to verify all air is removed from the system. Failure to properly bleed the brake system could adversely affect braking, which could result in death or serious injury. (00585c)

1. Bleed brake system. See BLEED BRAKES (Page 3-60).
2. Install right side cover.
3. Install right saddlebag. See SADDLEBAGS (Page 3-161).

### A WARNING

After repairing the brake system, test brakes at low speed. If brakes are not operating properly, testing at high speeds can cause loss of control, which could result in death or serious injury. (00289a)

4. Operate motorcycle at low speeds to verify that braking systems operate properly.

DOT 4 brake fluid will damage painted and body panel surfaces it

| PART NUMBER | TOOL NAME                  |
|-------------|----------------------------|
| BB200A      | BASIC VACUUM BRAKE BLEEDER |

**NOTICE**

comes in contact with. Always use caution and protect surfaces from spills whenever brake work is performed. Failure to comply can result in cosmetic damage. (00239c)

**NOTE**

- Procedure for draining brake fluid is the same for both the front and the rear brake systems.
- Both front and rear brake systems are affected when removing ABS module.

1. Remove master cylinder reservoir cap of the affected system.

2. See Figure 3-60. Remove cap (1) from bleeder screw (2).

3. Using vacuum brake bleeder to drain system.

Special Tool: BASIC VACUUM BRAKE BLEEDER (BB200A)

a. Attach vacuum brake bleeder to a caliper bleeder screw. Loosen screw 3/4 turn.

b. Operate vacuum bleeder to evacuate all fluid from master cylinder and line.

c. If needed: Repeat with remaining calipers.

4. Using brake lever or pedal to drain system.

a. Install a length of clear plastic tubing over bleeder screw.

b. Place free end of tubing in a suitable container.

c. Open bleeder screw one-half turn.

d. Pump brake lever or pedal repeatedly to drain brake fluid.

5. Close bleeder screw. Tighten. Refer to Table 3-8..

6. Wipe out any remaining fluid inside master cylinder reservoir with a clean, lint-free cloth.

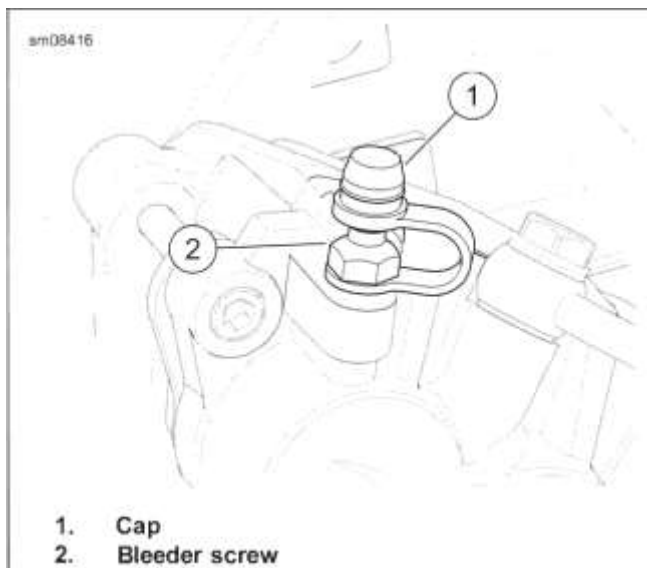


Figure 3-60. Bleeder Screw (Typical)

**FILL AND BLEED**

| PART NUMBER | TOOL NAME                  |
|-------------|----------------------------|
| BB200A      | BASIC VACUUM BRAKE BLEEDER |
| HD-48650    | DIGITAL TECHNICIAN II      |

| FASTENER   | TORQUE VALUE  |              |
|--|---------------|--------------|
| Brake bleeder screw, front                           | 72-108 in-lbs | 8.1-12.2 N-m |
| Brake bleeder screw, rear                            | 75-102 in-lbs | 8.5-11.5 N-m |
| Brake master cylinder, front, reservoir cover screws | 12-15 in-lbs  | 1.4—1.7 N-m  |
| Brake master cylinder, rear, reservoir cover screws  | 12-15 in-lbs  | 1.4-1.7 N-m  |

| PART NUMBER | CONSUMABLE                                       |
|-------------|--|
| 418007xx    | Harley-Davidson Platinum Label DOT 4 Brake Fluid |

**A WARNING**

A plugged or covered relief port can cause brake drag or lock-up, which could lead to loss of control, resulting in death or serious injury. (00288a)

**A WARNING**

When any hydraulic brake component, line or connection is loosened or replaced on an ABS motorcycle, Digital Technician II must be used during the brake bleeding procedure to verify all air is removed from the system. Failure to properly bleed the brake system could adversely affect braking, which could result in death or serious injury. (00585c)

**NOTICE**

DOT 4 brake fluid will damage painted and body panel surfaces it comes in contact with. Always use caution and protect surfaces from spills whenever brake work is performed. Failure to comply can result in cosmetic damage. (00239c)

- If DOT 4 brake fluid contacts painted surfaces, IMMEDIATELY flush area with clear water.

3-8. Install bleeder screw cap.

### NOTICE

**Do not allow dirt or debris to enter the master cylinder reservoir. Dirt or debris in the reservoir can cause improper operation and equipment damage. (00205c)**

### NOTE

- *Procedure for filling and bleeding brake fluid is the same for both front and rear brake systems.*
- *For best results use BASIC VACUUM BRAKE BLEEDER (PART NUMBER: BB200A). If a vacuum brake bleeder is not available, use the following procedure.*

1. Verify brake system operation.
  - a. Verify master cylinder is level.
  - b. Remove cover from master cylinder reservoir.
  - c. Fill reservoir with brake fluid. Refer to Table 3-7.  
Harley-Davidson Platinum Label DOT 4 Brake Fluid (418007xx)
  - d. Verify proper operation of the master cylinder relief port by actuating brake pedal or lever. Fluid will break the fluid surface in the reservoir if internal components are working properly.

### NOTE

- *Monitor fluid level in the master cylinder reservoir. Add fluid before it empties to avoid drawing air into the brake lines.*
- **Dual caliper front brake system:** *Bleed both calipers.*

2. Bleed brake system.
  - a. Remove cap from bleeder screw.
  - b. Install end of clear plastic tubing over bleeder screw.
  - c. Place opposite end of clear plastic tubing in a clear container.
  - d. Operate brake lever or pedal to build hydraulic pressure.
  - e. Hold pressure with brake lever or pedal.
  - f. Open bleeder screw three-quarters of a turn.
  - g. Close bleeder screw as soon as brake lever or pedal has moved full range of travel.
  - h. Allow brake lever or pedal to return slowly to its released position.
  - i. Repeat until all air bubbles are purged and a solid column of fluid is observed in the bleeder tube.
  - j. Tighten bleeder screw to specification. Refer to Table

- k. Fill reservoir with brake fluid. Refer to Table 3-7.  
Harley-Davidson Platinum Label DOT 4 Brake Fluid  
(418007xx)

3. Refer to Table 3-8. Install master cylinder reservoir cover:

- a. Verify master cylinder cover gasket bellows is not extended.
- b. Verify gasket and sealing surfaces are free of debris.
- c. **Front master cylinder reservoir:** Install cover with vent holes facing rear. Install cover screws. Tighten.

Torque: 12-15 **in-lbs** (1.4-1.7 N-m) *Brake master cylinder, front, reservoir cover screws*

- d. **Rear master cylinder reservoir:** Install cover screws. Tighten.

Torque: 12-15 **in-lbs** (1.4-1.7 N-m) *Brake master cylinder, rear, reservoir cover screws*

4. ABS models: Connect DT II and perform "ABS Service" procedure.

Special Tool: DIGITAL TECHNICIAN II (HD-48650)

**A WARNING**

**Be sure that all lights and switches operate properly before operating motorcycle. Low visibility of rider can result in death or serious injury. (00316a)**

5. Check operation of brake lamp.

**A WARNING**

**After servicing brakes and before moving motorcycle, pump brakes to build brake system pressure. Insufficient pressure can adversely affect brake performance, which could result in death or serious injury. (00279a)**

**A WARNING**

**After repairing the brake system, test brakes at low speed. If brakes are not operating properly, testing at high speeds can cause loss of control, which could result in death or serious injury. (00289a)**

6. Test ride motorcycle. Repeat the bleeding procedure if brakes feel spongy.

**Table 3-7. Fluid Level**

| ITEM            | SPECIFICATION                   |
|-----------------|---------------------------------|
| Front reservoir | Boss or ridge with range window |
| Rear reservoir  | Ledge or range window           |

**Table 3-8. Torque Specifications**

| COMPONENT            | TORQUE                              |
|----------------------|-------------------------------------|
| Bleeder screw, front | 72-108 <b>in-lbs</b> (8.1-12.2 N-m) |
| Bleeder screw, rear  | 75-102 <b>in-lbs</b> (8.5-11.5 N-m) |
| Front cover          | 12-15 <b>in-lbs</b> (1.4-1.7 N-m)   |
| Rear cover           | 12-15 <b>in-lbs</b> (1.4-1.7 N-m)   |

**PREPARE**

1. Remove left saddlebag. See SADDLEBAGS (Page 3-161).

**REMOVE**

1. See Figure 3-61. Pull side cover away to release mounting studs from grommets (1).

**INSTALL**

1. Install side cover.
  - a. Align side cover with grommets (1).
  - b. Press side cover until fully seated.

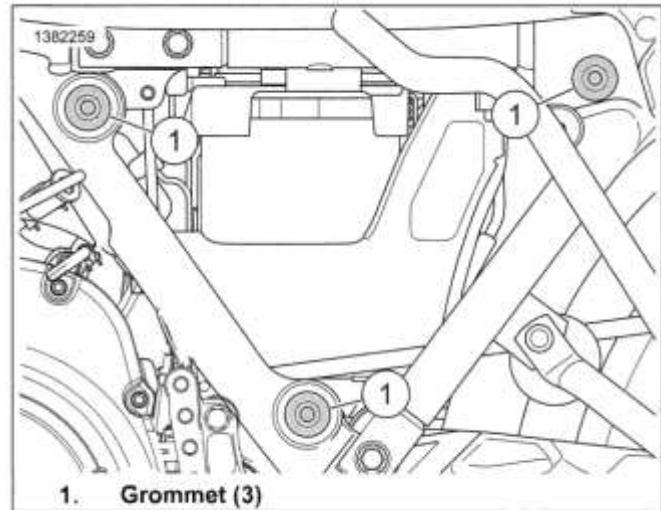


Figure 3-61. Left Side Cover

**COMPLETE**

1. Install left saddlebag. See SADDLEBAGS (Page 3-161).

## PREPARE

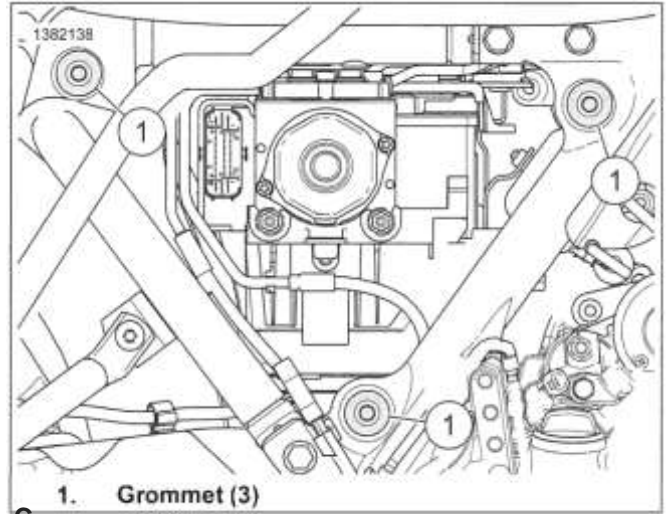
1. Remove right saddlebag. See SADDLEBAGS (Page 3-161)

## REMOVE

1. See Figure 3-62. Pull side cover away to release mounting studs from grommets (1).

## INSTALL

1. Install side cover.
  - a. Align side cover with grommets (1).
  - b. Press side cover until fully seated.



C  
O

Figure 3-62. Right Side Cover

**COMPLETE** 1. Install right saddlebag. See SADDLEBAGS (Page 3-161).

**CHECK FOR OIL LEAK****Fork Oil Seals**

The fork oil seal allows a fine film of oil to lubricate the fork sliding surface.

- The oil film is more visible after continuous high-speed compression and rebound movement.
- Due to greater lubrication needs, larger forks have a greater amount of oil film than smaller forks.

**Check Oil Leak**

1. Observe oil ring.
2. Wipe fork clean.
3. Ride motorcycle over bumpy road or complete six braking events.
4. See Figure 3-63. Check fork slider tube for oil.
  - a. If a normal oil/dust film (1,2) is present, there is no leak.
  - b. If an oil run or drip (3) is present, perform procedure two or three more times to confirm oil leak.

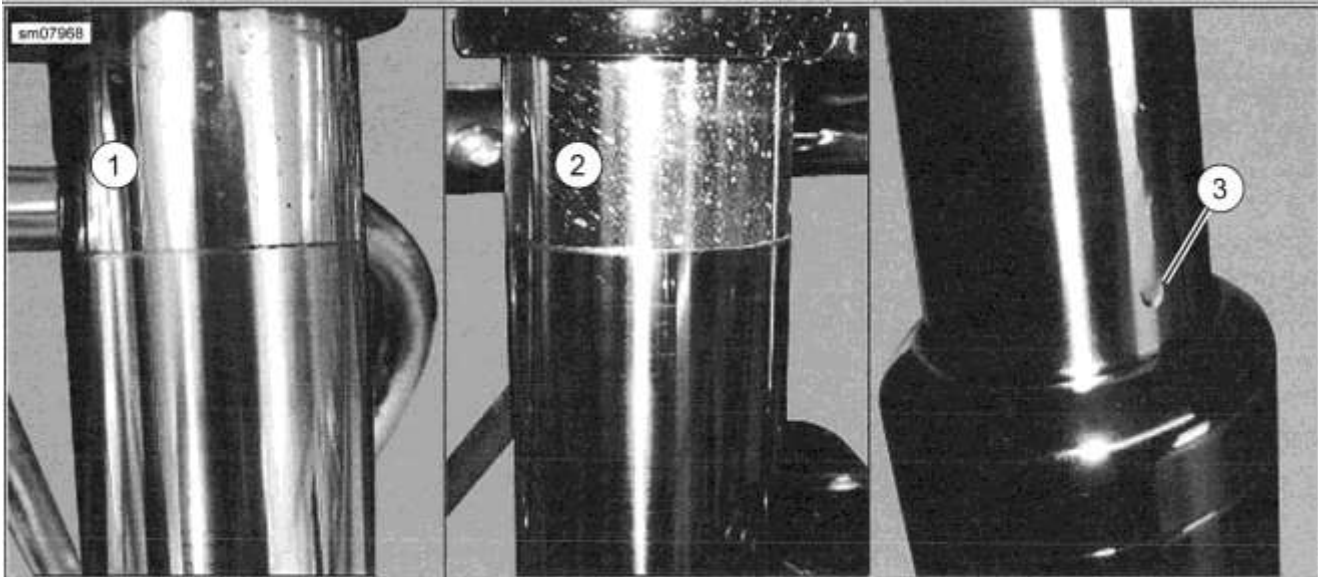


Figure 3-63. Front Forks

1. Normal oil/dust film
2. Normal oil/dust film

**3. Drip****PREPARE****NOTICE**

**When lifting a motorcycle using a jack, be sure jack contacts both lower frame tubes where down tubes and lower frame tubes converge. Never lift by jacking on cross-members, oil pan, mounting brackets, components or housings. Failure to comply can cause serious damage resulting in the need to perform major repair work. (00586d)**

1. Raise the front wheel.
  2. Remove front wheel. See FRONT WHEEL (Page 3-12).
  3. Remove front fender. See FRONT FENDER (Page 3-134).
  4. Remove brake caliper. See FRONT BRAKE CALIPER (Page 3-40).
    - a. Leave brake hose attached.
    - b. Support from engine guard.

5. **Road King models:** Remove headlamp nacelle. See HEADLAMP NACELLE (Page 3-87).

6. **Fairing models, fork-mounted:** Remove dash panel. See FAIRING: FORK MOUNTED (Page 3-89).
7. **Fairing models, frame-mounted:** Remove instrument bezel. See FAIRING: FRAME MOUNTED (Page 3-100).

**REMOVE**

1. See Figure 3-64. Loosen upper pinch screw (1) but do not remove.
2. Remove fork.
  - a. Hold fork slider to prevent fork from dropping.
  - b. Loosen lower pinch screws (2).
  - c. Slide fork tube down to remove.
3. If necessary, remove screws (3). Remove slider covers.



## INSTALL

| FASTENER                          | TORQUE VALUE |             |
|-----------------------------------|--------------|-------------|
| Fork bracket to fork pinch screws | 14-18 ft-lbs | 19-24.4 N-m |
| Fork slider cover screws          | 24-48 in-lbs | 2.7-5.4 N-m |

| PART NUMBER | CONSUMABLE   |
|-------------|--|
| Loctite 246 | LOCTITE 246 HIGH TEMPERATURE MEDIUM STRENGTH BLUE THREADLOCKER |

1. See Figure 3-64. If removed, install fork covers.

- a. Apply threadlocker to threads of screws (3).  
LOCTITE 246 HIGH TEMPERATURE MEDIUM STRENGTH BLUE THREADLOCKER (Loctite 246)
- b. Tighten.  
Torque: 24-48 in-lbs (2.7-5.4 N-m) *Fork slider cover screws*
- c. HDI, JPN, ENG, AUS: See Figure 3-65. If removed, install rubber bumper flush with the end and centered on the outboard surface of the fork cover.

2. Slide fork tube into place.

3. Set fork height:

- a. Visual method: See Figure 3-66. Set fork height so top rear surface (1) of upper fork bracket is midway of the tapered area (2) at top of fork.
- b. Measurement method: See Figure 3-67. Set top of fork to a dimension (A) from the top rear of the lower fork bracket.  
8.635-8.755 in (219.33-222.37 mm)

4. See Figure 3-64. Tighten lower fork bracket pinch screws (2) in sequence:

- a. Tighten upper screw:  
Torque: 14-18 ft-lbs (19-24.4 N-m) *Fork bracket to fork pinch screws*
- b. Tighten lower screw:  
Torque: 14-18 ft-lbs (19-24.4 N-m) *Fork bracket to fork pinch screws*
- c. Repeat previous steps one time.

5. Tighten upper pinch screw.

- a. Verify that upper fork bracket is seated against the upper dust shield.
- b. Verify that upper fork bracket is evenly positioned on both fork tubes.
- c. Tighten upper pinch screw (1):  
Torque: 14-18 ft-lbs (19-24.4 N-m) *Fork bracket to fork pinch screws*

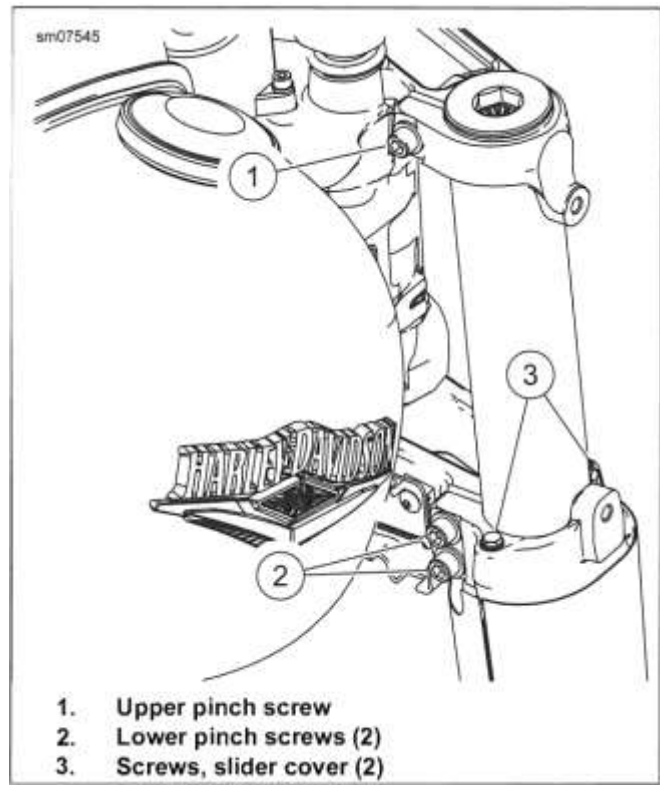


Figure 3-64. Front Fork Attachment

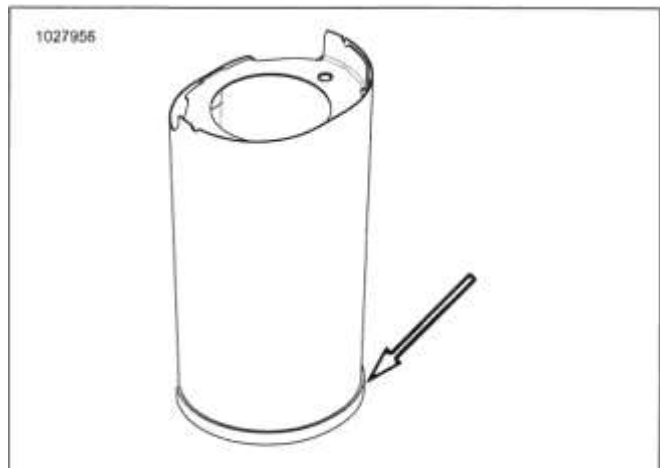
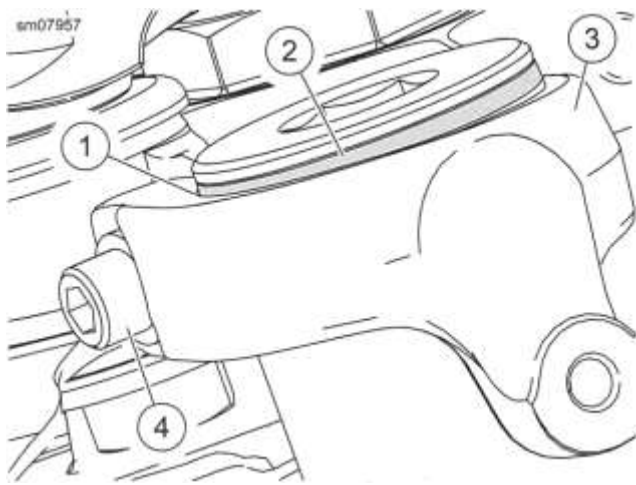


Figure 3-65. Fork Cover Bumper



1. Top rear surface
2. Tapered area
3. Upper fork bracket
4. Upper pinch screw

- a. Fork tube plug is under spring pressure. Have a firm grasp on plug as it is removed.
  - b. Remove and discard O-ring (2).
4. Remove sleeve (3), spacer (4) and spring (5) from fork assembly.

Figure 3-66. Fork Height

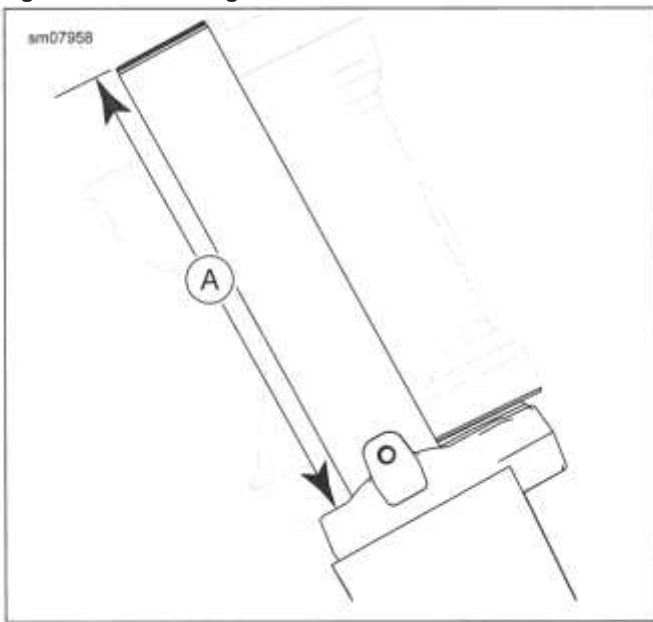


Figure 3-67. Measured Fork Height

**DISASSEMBLE**

| PART NUMBER | TOOL NAME        |
|-------------|------------------|
| HD-41177    | FORK TUBE HOLDER |

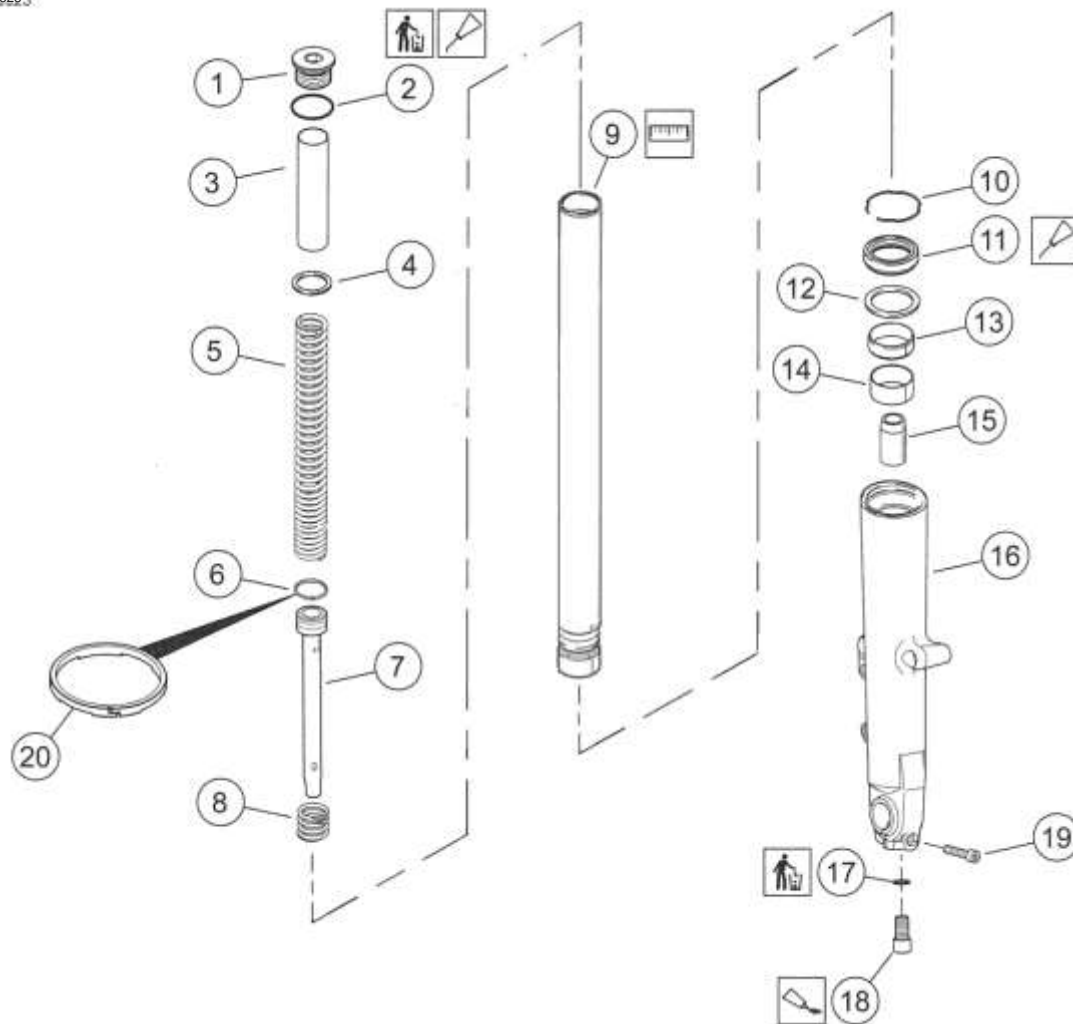
**Initial Disassembly**

*NOTE*

Always use soft jaws when placing any fork components into vise.

1. See Figure 3-68. If performing complete disassembly, clamp lower end of fork slider in a soft-jawed vise. Loosen lower screw (18). Do not remove now.
2. Install fork tube in fork tube holder with fork vertical. Special Tool: FORK TUBE HOLDER (HD-41177)
3. Remove fork tube plug (1).





1. Fork tube plug
2. O-ring
3. Sleeve
4. Spacer
5. Spring
6. Wear ring, damper tube
7. Damper tube
8. Rebound spring
9. Fork tube
10. Retaining clip

11. Seal
12. Slider spacer
13. Slider bushing
14. Fork tube bushing
15. Lower stop
16. Fork slider
17. Copper washer
18. Screw (metric)
19. Pinch screw
20. Reliefs in wear ring

Figure 3-68. Fork Assembly

### Fork Drain

1. **NOTE**  
*Drain fork oil into a suitable container.*

*If only performing a fork oil change, go to Assemble (Page 3-68), Final Fill.*

Drain fork oil.

- a. Slowly pump fork tube and slider at least ten times.
- b. Allow 10-15 minutes for fork to drain completely.

### Complete Disassembly

1. Remove screw (18).
  - a. Position fork horizontal.
  - b. Temporarily install spring, spacer and sleeve.
  - c. Apply pressure to spring to prevent damper from rotating and remove screw (18).
  - d. Remove copper washer (17). Discard washer.
  - e. Remove sleeve, spacer and spring.



2. Remove fork tube.
  - a. Remove retaining clip (10).
  - b. Expand fork slider and tube against each other repeatedly (in a slide-hammer effect) to remove fork tube.
  - c. Remove fork tube bushing (14), slider bushing (13), spacer (12), seal (11) and retaining clip (10) from fork tube.
  - d. Remove lower stop (15) from end of fork tube.
3. Tip fork tube upside down to remove damper tube (7) with rebound spring (8).
4. Remove rebound spring (8) and wear ring (6) from damper tube.

## CLEAN AND INSPECT

1. Clean all parts.
2. Inspect parts for wear or damage. Replace parts if necessary.
3. Inspect OD of slider bushing and ID of fork tube bushing.
  - a. If coating is worn through (metallic substrate showing), replace bushing.
  - b. Inspect for distortion.
  - c. If deep scratches or scoring are found, replace bushing. Also inspect mating components for similar wear. Replace or repair as necessary.
4. Check fork tube and slider for scoring, scratches and abnormal wear.
5. Inspect fork tube for nicks from stones and road debris, especially in area where seal contacts it. Replace if necessary.
6. See Figure 3-69. Check runout with a dial indicator.
  - a. Set fork tube on V-blocks.
  - b. Replace fork if runout exceeds:  
0.008 in (0.2 mm)

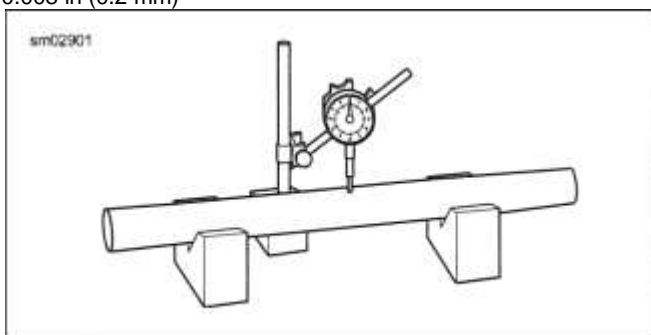


Figure 3-69. Measure Fork Tube Runout

## Initial Assembly

### NOTE

Lubricate all seal lips, quad rings and O-rings with HARLEY-DAVIDSON SEAL GREASE during assembly.

## ASSEMBLE

| PART NUMBER | TOOL NAME            |
|-------------|----------------------|
| HD-41177    | FORK TUBE HOLDER     |
| HD-59000B   | FORK OIL LEVEL GAUGE |

| FASTENER                   | TORQUE VALUE |           |
|----------------------------|--------------|-----------|
| Fork slider assembly screw | 30-37 ft-lbs | 40-50 N-m |

| PART NUMBER | CONSUMABLE                  |
|-------------|-----------------------------|
| 62600026    | TYPE "E" HYDRAULIC FORK OIL |
| 99818-97    | LOCTITE 565 THREAD SEALANT  |

1. See Figure 3-68. Assemble fork tube.
  - a. Coat OD of slider bushing (13) and fork tube bushing (14) with clean fork oil.
  - b. Expand slider bushing only enough to slip into groove of fork tube (9).
  - c. Install fork tube bushing and slider spacer (12) onto fork tube. Slide down until they contact slider bushing (13).
  - d. Wrap masking tape over edge of fork tube to protect fork oil seal during installation.
  - e. With the garter spring side toward the fork slider (16), slide new fork oil seal (11) down fork tube until it contacts slider spacer (12).
  - f. Remove masking tape from fork tube.

### NOTE

Screw (18) can be reused unless damaged.

2. Install damper tube (7).
  - a. Install fork tube horizontally in fork tube holder.  
Special Tool: FORK TUBE HOLDER (HD-41177)
  - b. Install new wear ring (6) in groove of damper tube (7). Install with reliefs (23) down.
  - c. Install rebound spring (8) on opposite end.
  - d. Slide damper tube into fork tube, small end first, until it passes through hole at bottom of fork tube. Install lower stop (15) at end of damper tube.
  - e. Install fork spring (5) with the tightly wound coils toward the bottom.
  - f. Install spacer (4) and sleeve (3).
  - g. Slide fork slider onto fork tube.
  - h. Apply threadlocker to screw (18). Loosely install screw and new copper washer (17).

LOCTITE 565 THREAD SEALANT (99818-97)

- i. Remove from fork holder.
- j. While compressing spring, tighten screw (18).  
Torque: 30-37 ft-lbs (40-50 N-m) *Fork slider assembly screw*

3. See Figure 3-70. Install fork oil seal.

- a. Clamp lower end of fork slider in a soft-jawed vise.
- b. Using FORK SEAL DRIVER (PART NUMBER: HD-45305) like a slide hammer, drive fork oil seal down until installer contacts fork slider.
- c. Remove tool.
- d. See Figure 3-68. Install retaining clip (10) in the fork slider groove.

4. Loosely install axle holder (22) with flat washers (21), lockwashers (20) and nuts (19) on right fork slider.

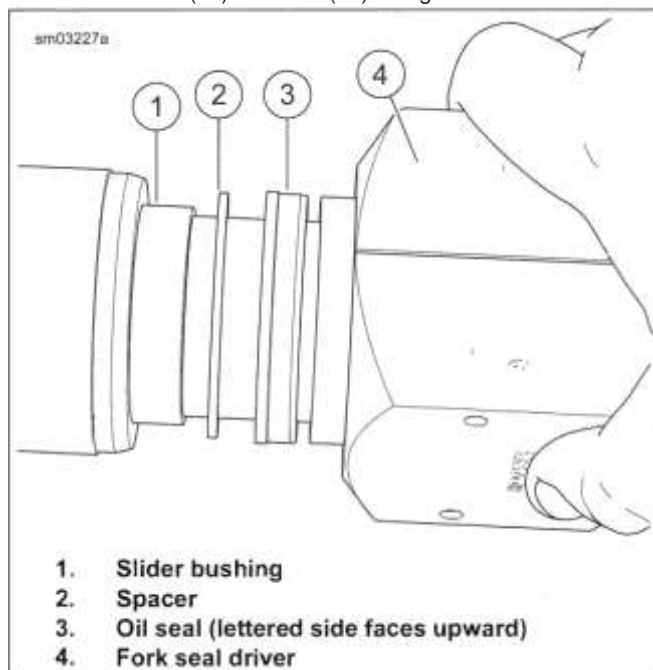


Figure 3-70. Assembled Fork Seal Driver

### Final Fill

1. Clamp fork slider vertically in fork tube holder.  
Special Tool: FORK TUBE HOLDER (HD-41177)
2. See Figure 3-68. Remove fork sleeve (3), spacer (4) and spring (5) from fork tube.
3. Pour hydraulic fork oil directly into fork tube.  
Volume: 24 fl oz (710 ml)  
Consumable: TYPE "E" HYDRAULIC FORK OIL (62600026)
4. Slowly pump fork tube until some resistance is felt. Then pump a few more times.
5. See Figure 3-71. Adjust fork oil level.
  - a. Adjust collar (3) of fork oil level gauge to: **Standard models:** Dimension: 3.70 in (94 mm). **Low models:** Dimension: 3.54 in (90 mm).

Special Tool: FORK OIL LEVEL GAUGE (HD-

59000B)

- b. With the fork tube bottomed in the fork slider, insert tube (2) of gauge until collar (3) rests flat on top of fork tube.
- c. Draw excess oil from fork with plunger. If no oil is drawn out, add a small amount to the fork tube and repeat.

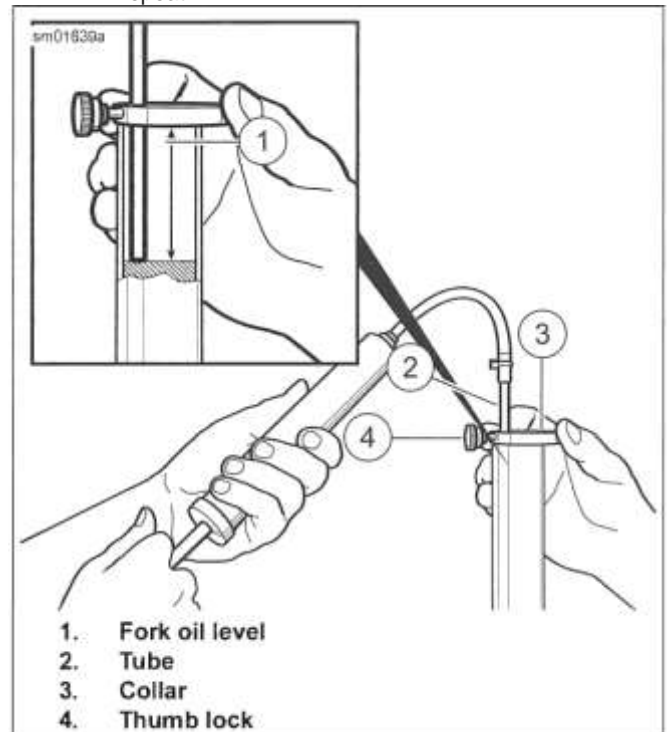


Figure 3-71. Oil Level Gauge

### Complete Assembly

1. See Figure 3-68. Extend the fork. Install fork spring (5), spacer (4) and sleeve (3) into fork tube with the tighter wound coils at the bottom.
2. Remove fork slider from fork holding tool. Clamp fork tube into fork holding tool.
3. Install new O-ring (2) onto fork tube plug (1). Install fork tube plug. Tighten to 30-80 N-m (22-59 ft-lbs).
4. Install fork and assemble motorcycle. See Install (Page 3-65).

### COMPLETE

1. Install front fender. See FRONT FENDER (Page 3-134).
2. Install front wheel. See FRONT WHEEL (Page 3-12).
3. Install front caliper. See FRONT BRAKE CALIPER (Page 3-40).

4. **Road King models:** Install headlamp nacelle. See 6. **Fairing models, frame-mounted:** Install instrument bezel.  
HEADLAMP NACELLE (Page 3-87). See FAIRING: FRAME MOUNTED (Page 3-100).
5. **Fairing models, fork-mounted:** Install dash panel. See FAIRING: FORK MOUNTED (Page 3-89).



**PREPARE**

1. Disassemble motorcycle.
  - a. **Road King models:** Remove headlamp nacelle. See HEADLAMP NACELLE (Page 3-87).
  - b. **Fairing models, fork-mounted:** Remove inner fairing assembly. See FAIRING: FORK MOUNTED (Page 3-89).
  - c. **Fairing models, frame-mounted:** Remove instrument nacelle. See FAIRING: FRAME MOUNTED (Page 3-100).

**REMOVE****Upper Fork Bracket**

1. Disconnect wiring:
  - a. Left and right handlebar switch connectors.
  - b. **FLHRXS:** Front turn signal lamp connectors.
  - c. Ignition switch connector.
  - d. TGS connector.
  - e. Upper fork bracket ground connector.
  - f. Heated hand grip connectors, if equipped.
  - g. Cut cable straps securing hydraulic lines, clutch cable and wiring to handlebar risers.
2. *NOTE*  
Leave hand controls and switches installed on handlebar.  
  
If necessary, separate handlebar from upper fork bracket
  - a. Separate handlebar from handlebar risers. See HANDLEBAR (Page 3-125).
  - b. Carefully lay on protected fuel tank.
3. See Figure 3-72. Remove upper fork bracket.
  - a. Loosen pinch screw (3).
  - b. Loosen pinch screws (2).
  - c. Do not loosen pinch screws (12).
  - d. Lift off upper fork bracket and handlebar as an assembly. Carefully lay on protected fuel tank.
4. If necessary, disassemble upper fork bracket.
  - a. Remove handlebar risers and handlebar. See HANDLEBAR (Page 3-125).

- b. Remove ignition switch or fork lock. See IGNITION SWITCH (Page 8-16).

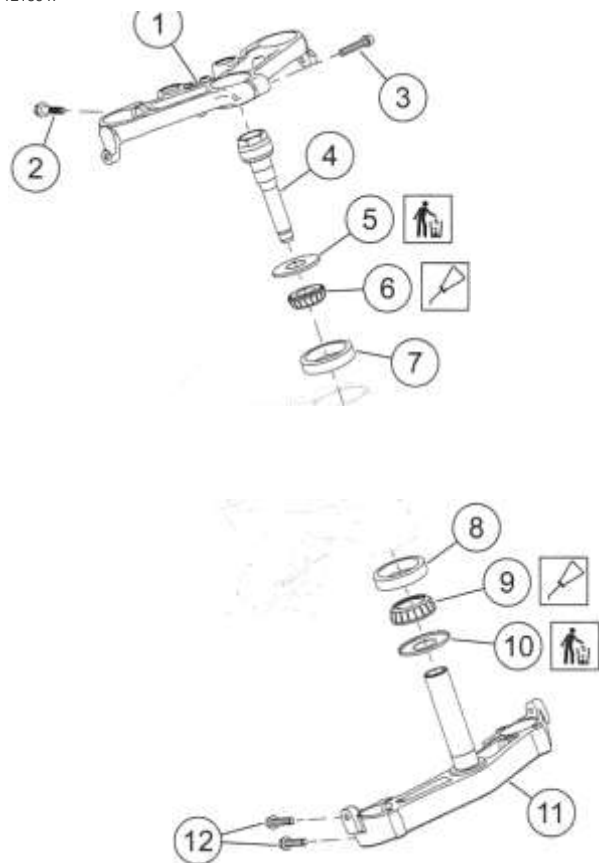
**Lower Fork Bracket**

1. Remove front forks. See FRONT FORK (Page 3-64).
2. Release brake lines from lower fork bracket.
3. **ABS models:** Disconnect WSS connector. Remove WSS.
4. *NOTE*  
Leave hand controls and switches assembled to handlebar.  
  
Remove upper fork bracket with handlebar attached. Secure assembly with elastic cords on a well-padded fuel tank. See **Upper Fork Bracket** in this section.
5. See Figure 3-72. Remove upper steering stem (4).
6. Remove lower steering stem/fork bracket (11).

**Steering Head Bearings**

*NOTE*  
Removing bearings destroys them. Always install new bearings upon assembly

1. See Figure 3-72. Remove bearing cones (6, 9) from upper stem and lower stems.
2. *NOTE*  
Internal reliefs in steering head allow punch access to the bearing cups.  
  
Drive both bearing cups (7, 8) out of steering head.
3. If necessary, remove screws securing brake line bracket. Remove bracket.



- 1. Upper fork stem bracket
- 2. Pinch screw, upper fork bracket (2)
- 3. Pinch screw, fork stem nut
- 4. Upper steering stem
- 5. Dust shield, upper
- 6. Bearing cone, upper
- 7. Bearing cup, upper
- 8. Bearing cup, lower
- 9. Bearing cone, lower
- 10. Dust shield, lower
- 11. Lower steering stem/fork bracket
- 12. Pinch screw, lower fork bracket (4)

Figure 3-72. Fork Stem and Brackets

**INSTALL**

| PART NUMBER | TOOL NAME                       |
|-------------|---------------------------------|
| HD-51727    | STEERING HEAD BEARING INSTALLER |

| FASTENER   | TORQUE VALUE |               |
|--|--------------|---------------|
| Brake line bracket to lower fork bracket screws                | 12-18 in-lbs | 1.4-2 N-m     |
| Fork bracket to fork pinch screws                              | 14-18 ft-lbs | 19-24.4 N-m   |
| Fork bracket to steer stem pinch screw                         | 22-26 ft-lbs | 29.8-35.2 N-m |
| Upper steering stem, 1st torque                                | 35 ft-lbs    | 47.5 N-m      |
| Upper steering stem, final torque: Fork mounted fairing models | 63 in-lbs    | 7.1 N-m       |

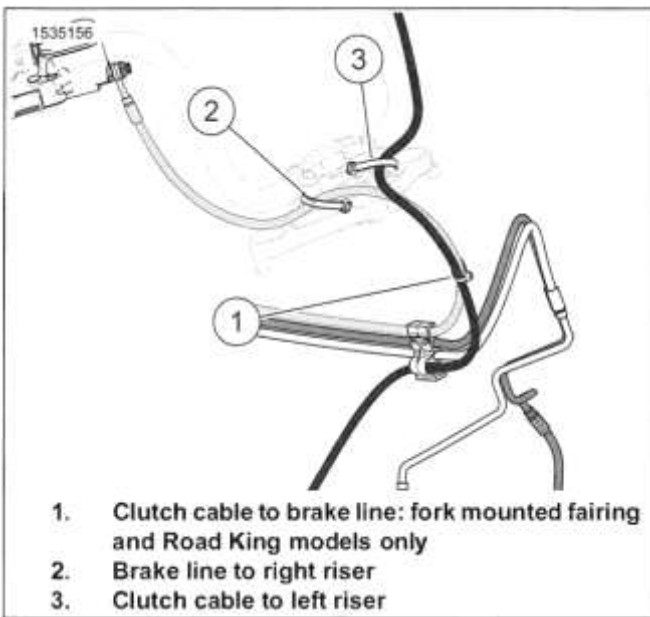
| FASTENER  | TORQUE VALUE |          |
|---|--------------|----------|
| Upper steering stem, final torque: Frame mounted fairing models | 192 in-lbs   | 21.7 N-m |
| Upper steering stem, final torque: Road King models             | 108 in-lbs   | 12.2 N-m |
| Upper steering stem, final torque: Trike models                 | 108 in-lbs   | 12.2 N-m |

| PART NUMBER | CONSUMABLE             |
|-------------|------------------------|
| 99857-97A   | SPECIAL PURPOSE GREASE |

**Upper Fork Bracket**

1. If necessary, assemble upper fork bracket. (3-125).
  - a. Install ignition switch or fork lock. See HANDLEBAR (Page 3-125).
2. Check front fork height. Use the measurement method. See FRONT FORK (Page 3-64).
3. If wheel is installed, raise vehicle to remove weight from front wheel.
4. See Figure 3-72. Install fork upper bracket.
  - a. Place upper fork bracket with handlebar over ends of forks and onto upper steering stem. If necessary, use a plastic deadblow hammer to tap the fork bracket onto the upper steering stem.
  - b. Hold upper fork bracket down tight against upper dust shield. Tighten pinch screw (3).  
Torque: 22-26 ft-lbs (29.8-35.2 N-m) *Fork bracket to steer stem pinch screw*
  - c. Verify that upper fork bracket is evenly positioned on both forks. Tighten upper fork pinch screws (2).  
Torque: 14-18 ft-lbs (19-24.4 N-m) *Fork bracket to fork pinch screws*
  - d. If handlebar was removed: Install handlebar. See HANDLEBAR (Page 3-125).
5. Connect wiring.
  - a. Connect left and right handlebar switch connectors.
  - b. FLHRXS: Connect front turn signal lamp connectors.
  - c. Connect ignition switch connector.
  - d. Connect TGS connector.
  - e. Connect upper fork bracket groundconnector.
  - f. Connect heated hand grip connectors, if equipped.
  - g. See Figure 3-73. Secure lines and wiring to handlebar risers with new cable straps.

- a. Install handlebar and risers. See HANDLEBAR (Page



**Figure 3-73. Capture Clutch and Brake Fluid Lines Lower Fork Bracket**

1. See Figure 3-72. Lubricate upper steering stem threads with special purpose grease. Apply grease on bearing rollers and cups.  
Consumable: SPECIAL PURPOSE GREASE (99857-97A)
2. Install lower steering stem/fork bracket (11) into steering head.
3. Install upper stem.
  - a. Hold lower steering stem/fork bracket up against lower cup (8).
  - b. Install upper stem (4) hand-tight.
  - c. Place wooden block between lower fork bracket and frame.
  - d. Tighten upper steering stem (4).  
Torque: 35 ft-lbs (47.5 N-m) *Upper steering stem, 1st torque*
  - e. Loosen upper steering stem 90-100 degrees. Tighten to specification. Refer to Table 3-9.
4. Install front forks. See FRONT FORK (Page 3-64).

**Table 3-9. Steering Stem Torque**

| MODEL                         | TORQUE                       |
|-------------------------------|------------------------------|
| Fairing models: fork mounted  | 63 <b>in-lbs</b> (7.1 N-m)   |
| Fairing models: frame mounted | 192 <b>in-lbs</b> (21.7 N-m) |
| Road King                     | 108 <b>in-lbs</b> (12.2 N-m) |
| Trike                         | 108 <b>in-lbs</b> (12.2 N-m) |

### Steering Head Bearings

*NOTE*

- Always install new bearings. Replace both bearings anytime either requires replacement.

*Install both bearing cups at the same time.*

1. Inspect the bores in the steering head. Remove any paint, rust or burrs.
2. See Figure 3-74. Install new bearing cups.  
  
Special Tool: STEERING HEAD BEARING INSTALLER (HD-51727)
3. *NOTE*  
*Upper dust shield has a larger OD than the lower dust shield.*  
  
See Figure 3-72. Assemble upper steer stem.
  - a. Install upper dust shield (5).
  - b. Press bearing cone (6) onto upper stem.
4. Assemble lower steer stem.
  - a. Install lower dust shield (10).
  - b. Press bearing cone (9) onto lower stem.
5. If removed, install brake line bracket with two screws. Tighten.  
Torque: 12-18 **in-lbs** (1.4-2 N-m) *Brake line bracket to lower fork bracket screws*



**Figure 3-74. Install Steering Head Bearing Cups**  
**COMPLETE**

1. Install front forks in lower fork bracket. Use measurement method to adjust height. See FRONT FORK (Page 3-64).
2. **ABS models:** Connect WSS cable. Secure to right steering head caddy. See FRONT WHEEL SPEED SENSOR (WSS) (Page 8-100).
3. Install upper fork bracket and handlebar. Do not tighten fork stem pinch screw. See STEERING HEAD (Page 3-71).

4. Assemble motorcycle.

- a. instrument nacelle. See FAIRING: FRAME
- a. **Road King models:** Install headlamp nacelle. See HEADLAMP NACELLE (Page 3-87).
- b. **Fairing models, fork-mounted:** Install inner fairing assembly. See FAIRING: FORK MOUNTED (Page 3-89).

- c. **Fairing models, frame-mounted:** Install the

MOUNTED (Page 3-100).

- 5. Adjust swing-back. See ADJUST AND LUBRICATE STEERING HEAD BEARINGS (Page 2-31).

## PREPARE

1. Remove rear wheel. See REAR WHEEL (Page 3-14).
2. Remove debris deflector from bottom of left side fork.
3. Loosen both lower shock absorber mounting bolts. Do not remove now.

## REMOVE

1. See Figure 3-75. Remove two screws (12) to free left rear fork bracket (11) with footrest attached.
2. Release rear brake hose and rear wheel speed sensor cable (ABS models) from rear fork.
3. Remove plug (1) from right side.

## 4. NOTE

- For best results, use an air impact wrench to remove the right side screw. Applying heat to the right side screw also improves removal.
- A 6-point socket is recommended to remove the pivot shaft screws.

Remove pivot shaft.

- a. Hold left side hex cup (9) and remove right side screw (2) from pivot shaft (6).
- b. Remove right hex cup (3).
- c. Remove pivot shaft, screw (10), left hex cup (9), rubber mount (8) and outer spacer (7) from the left side as an assembly.

5. Remove lower shock absorber bolts. Work rear fork free of transmission mount and rubber mount (4).

6. Remove right outer spacer (5) from fork tube.

7. Remove right rubber mount (4).

1. Plug
2. Right side screw
3. Right hex cup
4. Right rubber mount
5. Right outer spacer
6. Pivot shaft

7. Left outer spacer
8. Left rubber mount
9. Left hex cup
10. Left side screw
11. Fork bracket
12. Screw (2)

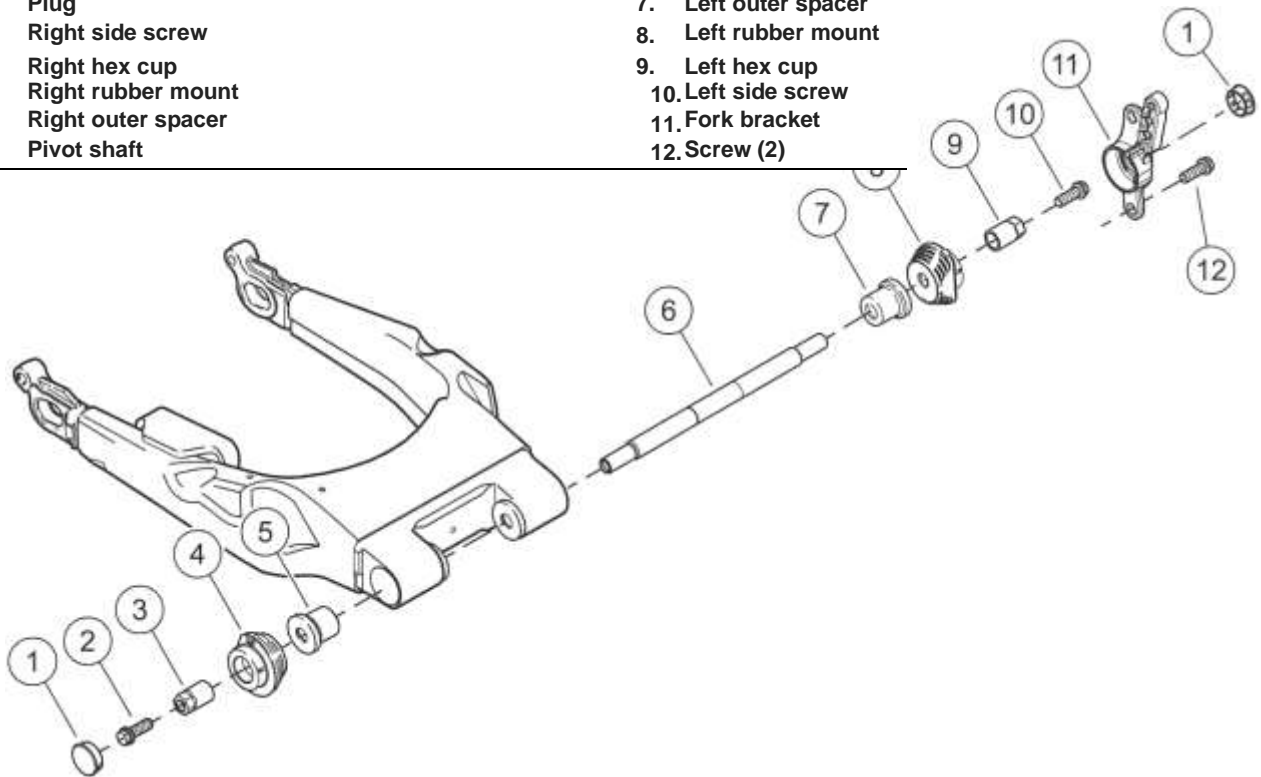


Figure 3-75. Rear Fork Mounting

## INSTALL

4.

| FASTENER                     | TORQUE VALUE |               |
|------------------------------|--------------|---------------|
| Rear fork bracket screws     | 55-65 ft-lbs | 74.6-88.1 N-m |
| Rear fork pivot shaft screws | 55-65 ft-lbs | 74.6-88.1 N-m |

| PART NUMBER | CONSUMABLE  |
|-------------|---|
| 98960-97    | ANTI-SEIZE LUBRICANT  |
| 99642-97    | LOCTITE 243 MEDIUM STRENGTH<br>THREADLOCKER AND SEALANT<br>(BLUE) |

- See Figure 3-76 . Install right side rubber mount.
  - With the slot on the outboard side between the 12 o'clock and 1 o'clock positions, install rubber mount on inner-right side of frame.
  - Make sure that index tab in mount cavity fully engages slot in rubber mount.
- Install fork.
  - Hold outer spacer in right side fork tube and move the fork into position.
  - Loosely attach shock absorbers.
  - Work the rear fork into final position between the transmission mount and the right rubber mount.
  - Coat pivot shaft with anti-seize. Avoid getting anti-seize in threads of pivot shaft.  
ANTI-SEIZE LUBRICANT (98960-97)
  - See Figure 3-75. Install pivot shaft from left side through fork and transmission mount. Guide end of pivot shaft through right rubber mount.
- Install left side components.
  - Install outer spacer (7) until seated against shoulder of pivot shaft.
  - Install left rubber mount (8) with the flat side inboard.
  - Install hex cup (9).
  - Rotate the left rubber mount (8) so the slot is between the 11 and 12 o'clock positions.
  - Install left side fork bracket (11) fitting index tab into slot of rubber mount.
  - Apply threadlocker to fork bracket screws (12). Secure left side fork bracket with footrest. Tighten.  
Torque: 55-65 ft-lbs (74.6-88.1 N-m) *Rear fork bracket screws*  
LOCTITE 243 MEDIUM STRENGTH  
THREADLOCKER AND SEALANT (BLUE) (99642-97)

Install pivot shaft screws (2, 10).

- Remove plugs (1).
- Apply threadlocker to pivot shaft screws (2, 10).  
LOCTITE 243 MEDIUM STRENGTH  
THREADLOCKER AND SEALANT (BLUE) (99642-97)
- Install screws. Tighten.  
Torque: 55-65 ft-lbs (74.6-88.1 N-m) *Rear fork pivot shaft screws*

5. Verify that rear fork assembly moves freely.

6. Install plugs (1).

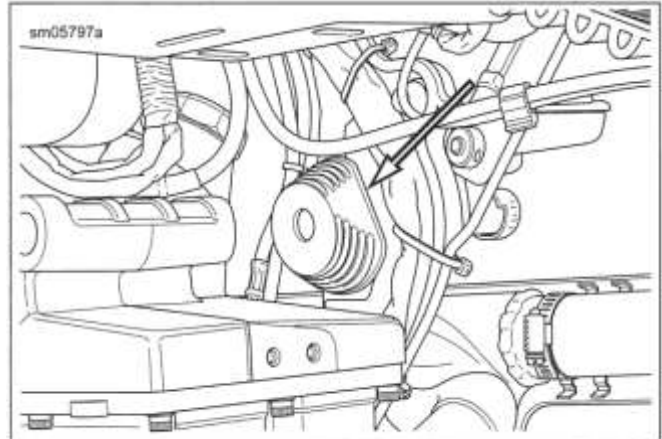
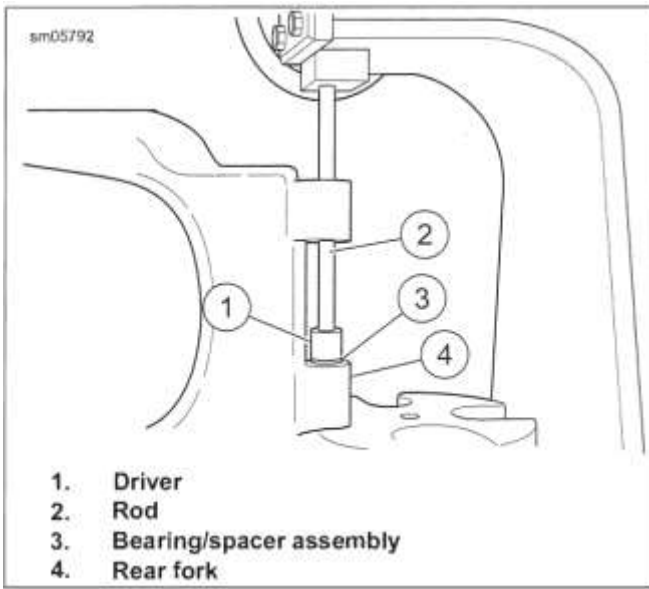


Figure 3-76. Right Side Mount

## DISASSEMBLE

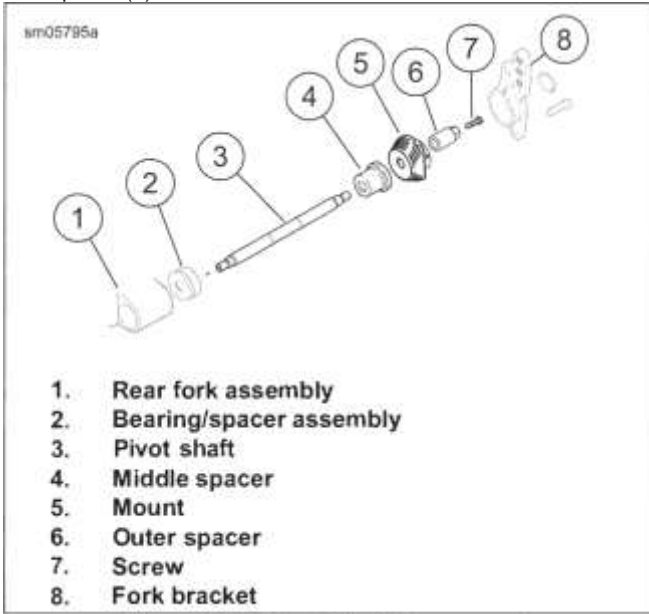
### Remove Bearings

- See Figure 3-77. Select a driver (1) slightly smaller than bearing spacer collar and a rod (2) long enough to allow pressing through upper bearing.
- Support fork (4) in a press with brake anchor weldment on top. Slide rod through the brake side bearing against driver. Verify that assembly is square and bearing bore is vertical.
- Press bearing/spacer assembly (3) from rear fork.
- Turn over fork. Press out brake side bearing in same manner.
- If bearings are replaced with new, press spacers out and retain for later use.



**Figure 3-77. Remove Rear Fork Bearing Disassemble Pivot Shaft/Mount**

1. See Figure 3-78. Remove screw (7).
2. Remove outer spacer (6), rubber mount (5) and middle spacer (4).



**Figure 3-78. Pivot Shaft Components**

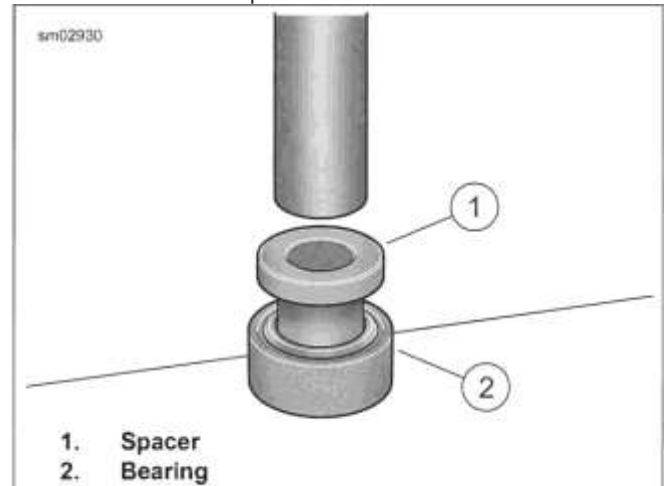
**ASSEMBLE**

| PART NUMBER | TOOL NAME                       |
|-------------|---------------------------------|
| HD-45327    | REAR SWINGARM BEARING INSTALLER |

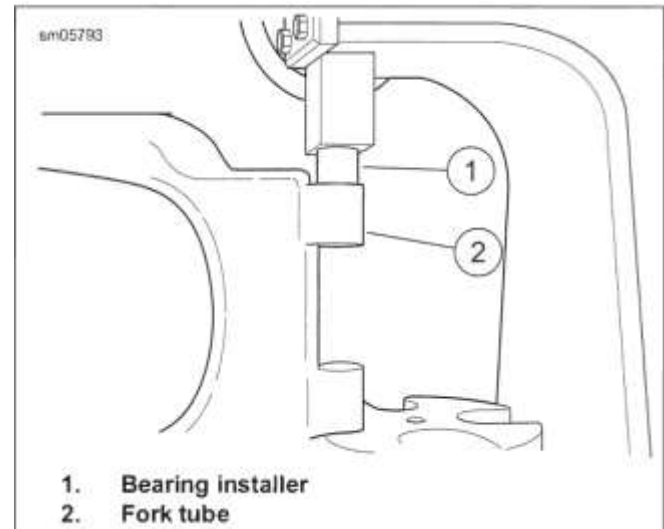
| PART NUMBER | CONSUMABLE             |
|-------------|------------------------|
| 99857-97A   | SPECIAL PURPOSE GREASE |

1. Assemble **new** rear fork bearings and spacers.
  - a. Place bearing on press plate.
  - b. See Figure 3-79. With collar topside, start spacer (1) into bearing (2).

- c. Press spacer until it bottoms against press plate.
2. Coat bearing bores in rear fork with grease.  
Consumable: SPECIAL PURPOSE GREASE (99857-97A)
  3. See Figure 3-80. Install bearings.
    - a. Support fork squarely on press bed with the brake anchor weldment on top.
    - b. Insert bearing into fork assembly with spacer down.
    - c. Use bearing installer (1) stamped **Brake Side**. Press bearing until shoulder on tool contacts fork tube (2).  
Special Tool: REAR SWINGARM BEARING INSTALLER (HD-45327)
    - d. Turn rear fork over.
    - e. Repeat process with remaining bearing using tool stamped **Drive Side**. Press bearing until it bottoms. Shoulder on press tool should **not** contact fork tube.



**Figure 3-79. Press Spacer into Bearing**



**Figure 3-80. Install Rear Fork Bearing (typical)**

**COMPLETE**

| FASTENER                     | TORQUE VALUE |             |
|------------------------------|--------------|-------------|
| Debris deflector screw       | 65-85 in-lbs | 7.3-9.6 N-m |
| Shock absorber mounting bolt | 63-70 ft-lbs | 85.4-95 N-m |





| PART NUMBER | CONSUMABLE  |
|-------------|---|
| 99642-97    | LOCTITE 243 MEDIUM STRENGTH<br>THREADLOCKER AND SEALANT<br>(BLUE) |

1. Remove lower shock absorber mounting bolts. Apply threadlocker to threads of bolts. Install and tighten.  
Torque: 63-70 ft-lbs (85.4-95 N-m) *Shock absorber mounting bolt*  
Consumable: LOCTITE 243 MEDIUM STRENGTH  
THREADLOCKER AND SEALANT (BLUE) (99642-97)
2. Install debris deflector. Tighten.  
Torque: 65-85 **in-lbs** (7.3-9.6 N-m) *Debris deflector screw*
3. Seat caliper bracket on anchor weldment of rear fork.
4. Capture rear brake line hose in two cable clips at top of right side fork. Rear cable clip also captures rear wheel speed sensor cable on ABS equipped motorcycles.
5. Install rear wheel. See REAR WHEEL (Page 3-14).

## PREPARE \_\_\_\_\_

1. Remove left saddlebag. See SADDLEBAGS (Page 3-161).

## REMOVE \_\_\_\_\_

### **Debris Deflector**

1. Loosen front screw.
2. Remove remaining screws.
3. Slide debris deflector forward and remove.

## INSTALL

| FASTENER               | TORQUE VALUE        |             |
|------------------------|---------------------|-------------|
| Debris deflector screw | 65-85 <b>in-lbs</b> | 7.3-9.6 N-m |

### **Debris Deflector**

1. Install debris deflector.
2. Install screws and tighten.

Torque: 65-85 **in-lbs** (7.3-9.6 N-m) *Debris deflector screw*

## COMPLETE \_\_\_\_\_

1. Install left saddlebag. See SADDLEBAGS (Page 3-161).

## PREPARE

**NOTE**

Remove and install one shock absorber at a time.

1. Remove saddlebags. See SADDLEBAGS (Page 3-161).
2. Raise rear of motorcycle.

## REMOVE

1. Remove upper and lower shock absorber mounting bolts, lockwashers and flat washers.
2. Remove shock absorber.

## CLEAN AND INSPECT

1. Inspect shock absorber for signs of leakage. Replace both shock absorbers if leak is found.
2. Inspect bushings for cracks and wear. Replace as necessary.

## INSTALL

| FASTENER                          | TORQUE VALUE |             |
|-----------------------------------|--------------|-------------|
| Rear shock absorber mounting bolt | 63-70 ft-lbs | 85.4-95 N-m |

| PART NUMBER | CONSUMABLE  |
|-------------|---|
| 99642-97    | LOCTITE 243 MEDIUM STRENGTH THREADLOCKER AND SEALANT (BLUE) |

**NOTE**

- See Figure 3-81. Install right shock absorber (1) with the rod end up.
  - Install right shock absorber with thicker end (3) of bushings facing frame.
  - Install left shock absorber (2) with the knob topside and facing forward.
1. Apply threadlocker to each mounting bolt.  
Consumable: LOCTITE 243 MEDIUM STRENGTH THREADLOCKER AND SEALANT (BLUE) (99642-97)
  2. Install shock absorber with mounting bolts, lockwashers and flat washers. Tighten.  
Torque: 63-70 ft-lbs (85.4-95 N-m) *Rear shock absorber mounting bolt*

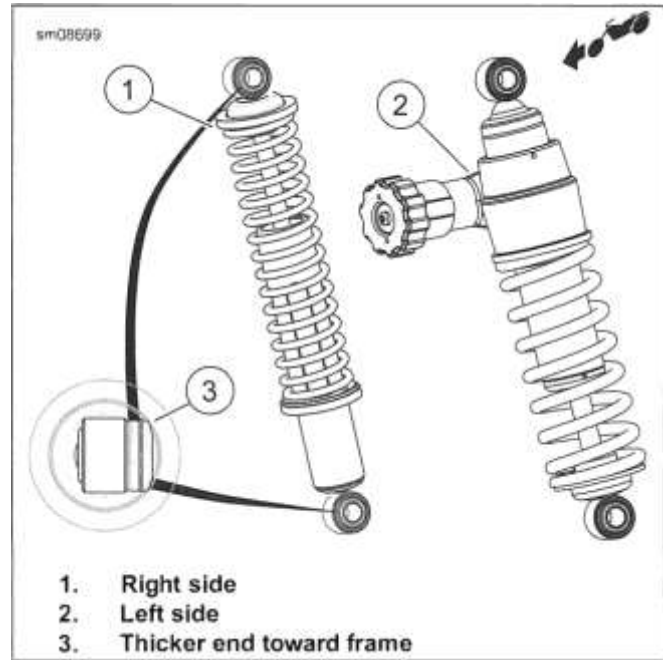


Figure 3-81. Manual Adjust Shock Absorber

## DISASSEMBLE AND ASSEMBLE: REAR SHOCK ADJUSTER

### Remove Shock Absorber Knob

1. Remove shock adjuster knob.
  - a. Remove screw and washer.
  - b. Hold a rag wrapped around the adjuster housing and knob to prevent loss of the detent ball and spring. Carefully remove the knob.
  - c. Remove detent ball and spring.

### Install Shock Absorber Knob

1. Install shock adjuster knob.
  - a. Press and hold detent ball onto end of spring. Install knob on adjuster housing.
  - b. Install washer and screw. Tighten securely.
  - c. Rotate knob to verify that the detent is properly assembled. Clicks are heard every half rotation.

## COMPLETE

1. Install saddlebags. See SADDLEBAGS (Page 3-161).
2. Lower rear wheel.

## PREPARE

1. Remove main fuse. See POWER DISCONNECT (Page 8-8).

## REMOVE

### Clutch Cable Disconnect

*NOTE*

*The two cable halves should only be taken apart if replacing the upper clutch cable or housing. Otherwise disconnect at clutch lever and leave two halves assembled.*

1. See Figure 3-82. Access two piece clutch cable.
  - a. Remove spring clip (3).
  - b. Remove clutch cable from upper clip (1).
  - c. Remove clip above cover.
  - d. Slide cover (2) up.
2. See Figure 3-83. Identify upper clutch cable (1) and red lock button (2).
3. *NOTE*  
*Inspect lock button (2). Replace if damaged.*  
  
See Figure 3-84. Unlock upper clutch cable (1).
  - a. Push lock button tabs (2) slightly inboard and then down to disengage.
4. Fully collapse cable (spring compressed) and push button in.
5. See Figure 3-85. Lift locking tab (1) from swaged ball end (2).
6. See Figure 3-86. Push swaged ball end (2) out from coupler (1) opposite side and slightly pull clutch lever in until locking tab is at top of window. Remove swaged ball end from coupler.
7. See Figure 3-87. Pry flex fingers (3) open and slide lower clutch cable (2) from housing (1).

### Clutch Cable: Lower End

1. Remove clutch cable.
  - a. Disconnect clutch cable at release cover. See CLUTCH RELEASE COVER (Page 5-9).
  - b. Disconnect clutch cable. See Clutch Cable Disconnect in this section.

### Clutch Cable: Upper End

1. Disconnect clutch cable. See Clutch Cable Disconnect in this section.
2. See Figure 3-88. Remove clutch cable routing.
  - a. Remove upper clutch cable (4) from brake line retainer (5).
  - b. Discard cable strap (3).
  - c. **Fork mounted fairings:** Discard cable strap (2) and remove clutch cable guide (1).
3. See Figure 3-89. Remove clutch cable.
  - a. Remove retaining ring (7).
  - b. Remove pivot pin (2).
  - c. Remove clutch hand lever (8).
  - d. Remove pin (3).
  - e. Remove clutch cable (4).

### Clutch Hand Control

1. Remove clutch hand control assembly.
  - a. Remove screws (5) and washers (4).
  - b. Remove lever bracket clamp (3).
  - c. Remove clutch lever bracket (1).

## CLEAN.ANDINSPECT

1. Inspect clutch lever and cable for wear or damage. Replace or repair as necessary.
2. Inspect clutch cable. Replace as necessary.

**NOTICE**

**The clutch control cable must be oiled and adjusted periodically to compensate for lining wear. Failure to oil and adjust the clutch control cable can result in equipment damage. (00203c)**

3. Lubricate clutch cable and hand lever pivot pin hole with HARLEY LUBE.

## INSTALL

| FASTENER                | TORQUE VALUE |           |
|-------------------------|--------------|-----------|
| Clutch hand lever screw | 60-80 in-lbs | 6.8-9 N-m |

### Clutch Hand Control

1. See Figure 3-89. Install clutch hand control assembly.
  - a. Install clutch lever bracket (1).
  - b. Install lever bracket clamp (3).
  - c. Install washers (4) and screws (5). Tighten.  
Torque: 60-80 **in-lbs** (6.8-9 N'm) *Clutch hand lever screw*

### Clutch Cable: Lower End

1. Install clutch cable.
  - a. Connect clutch cable at release cover. See CLUTCH RELEASE COVER (Page 5-9).
  - b. Connect clutch cable. See Clutch Cable Connect in this section.

### Clutch Cable: Upper End

1. See Figure 3-89. Install clutch cable.
  - a. Install clutch cable (9).
  - b. Install pin (10).
  - c. Install clutch hand lever (8).
  - d. Align lever return spring (11) and pivot bushing (12) into hole on clutch lever bracket (1).
  - e. Install pivot pin (2)
  - f. Install retaining ring (7).
2. See Figure 3-88. Secure clutch cable in position.
  - a. **Fork mounted fairings:** Align clutch cable guide with hole in handlebar.
  - b. Attach clutch cable guide (1) to handlebar and secure with cable strap (2).
  - c. Install cable strap (3) around upper clutch cable (4) and left handlebar lower clamp.
  - d. Install upper clutch cable in brake line retainer (5).
3. Connect clutch cable. See Clutch Cable Connect in this section.

### Clutch Cable Connect

1. See Figure 3-87. Install lower clutch cable (2) into housing (1).
2. See Figure 3-86. Pull clutch cable swaged ball end (2) out slightly from window and manipulate clutch lever to align coupler (1) with swaged ball end, then release.

#### NOTE

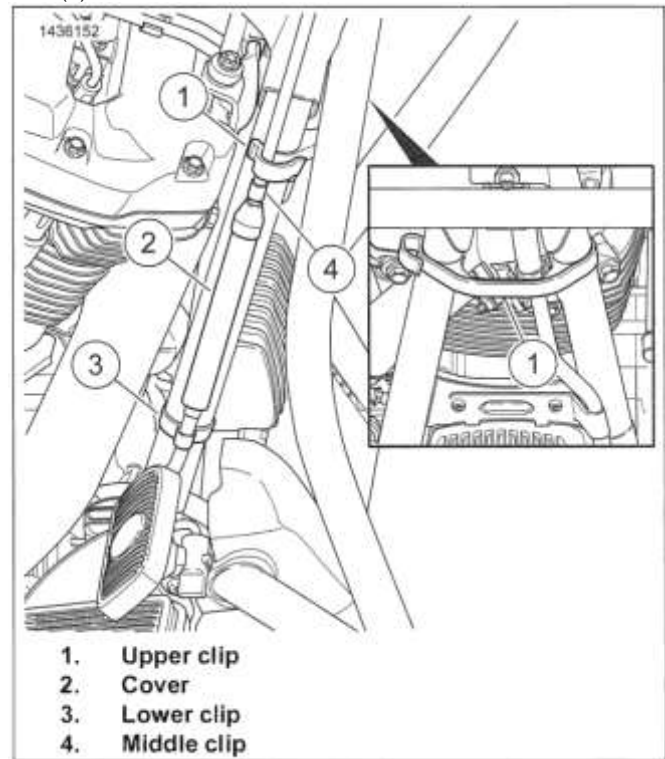
*Replace upper clutch cable if locking tab is damaged or missing.*

3. See Figure 3-85. Secure locking tab (1) over swaged ball end (2).
4. See Figure 3-89. Ensure clutch hand lever (8) is in full open position and ferrule is correctly seated in clutch lever bracket (1).

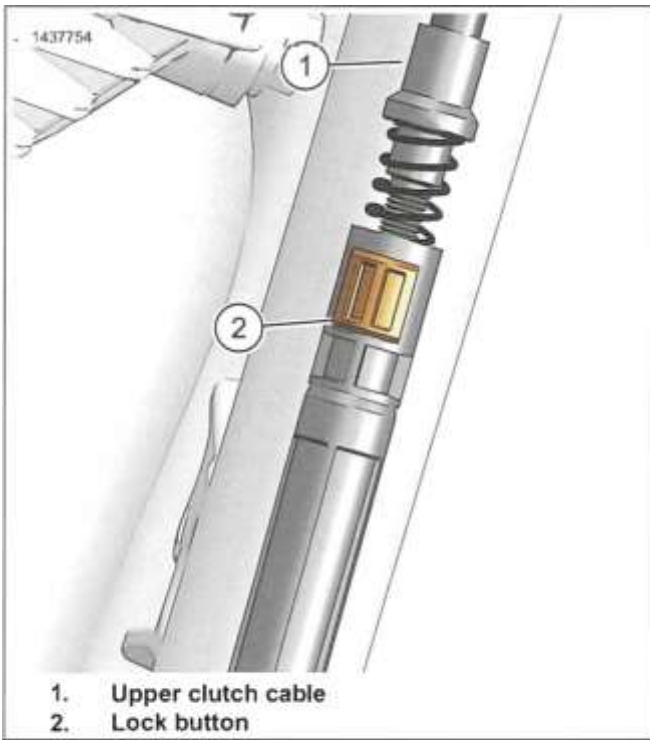
#### NOTE

*See Figure 3-84. **Inspect lock button** (2). Replace if damaged.*

5. Disengage lock button allowing upper clutch cable spring to set free-play at clutch lever.
6. See Figure 3-83. Push in lock button (2).
7. Check clutch operation.
8. See Figure 3-82. Slide cover (2) down and install spring clips (1).

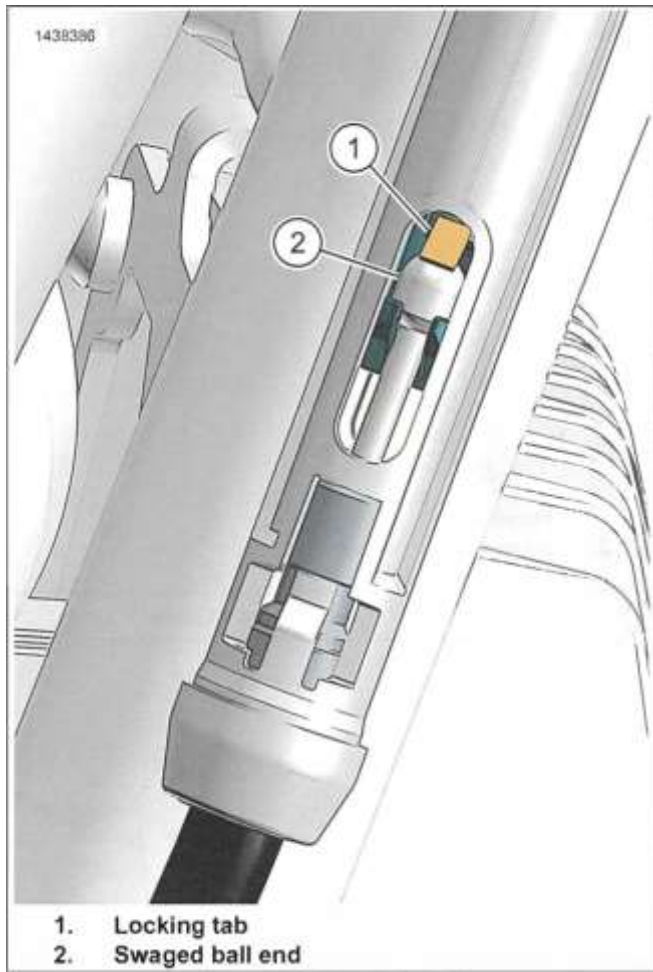


**Figure 3-82. Clutch Adjuster Location**



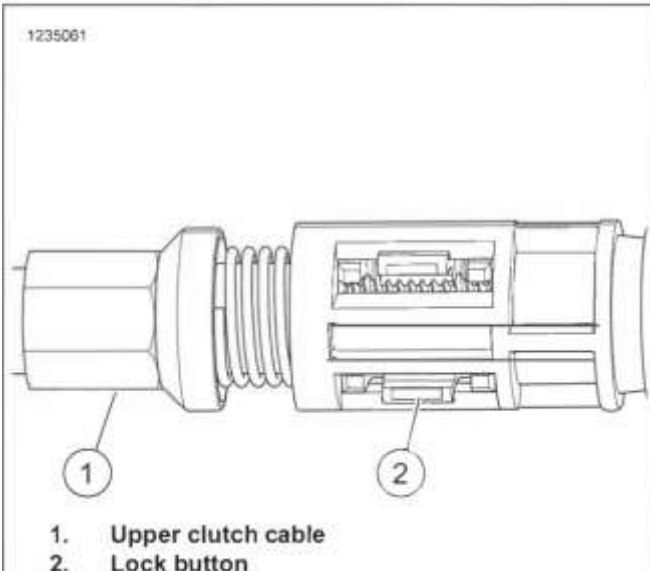
- 1. Upper clutch cable
- 2. Lock button

Figure 3-83. Lock Button



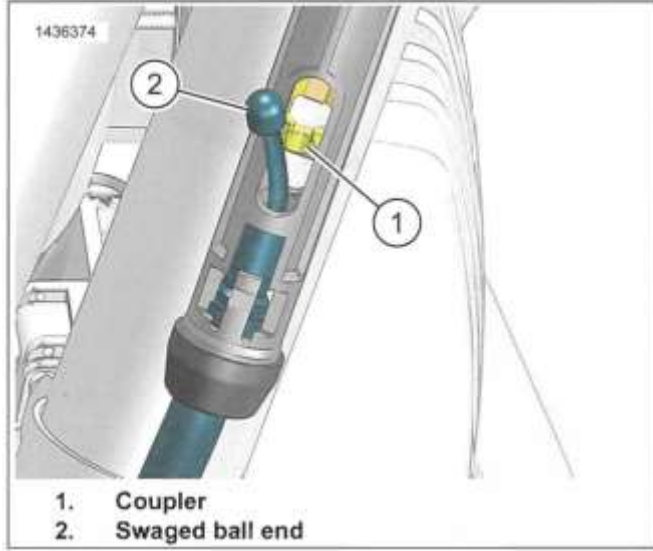
- 1. Locking tab
- 2. Swaged ball end

Figure 3-85. Locking Tab



- 1. Upper clutch cable
- 2. Lock button

Figure 3-84. Compressed Upper Clutch Cable



- 1. Coupler
- 2. Swaged ball end

Figure 3-86. Coupler Disengagement

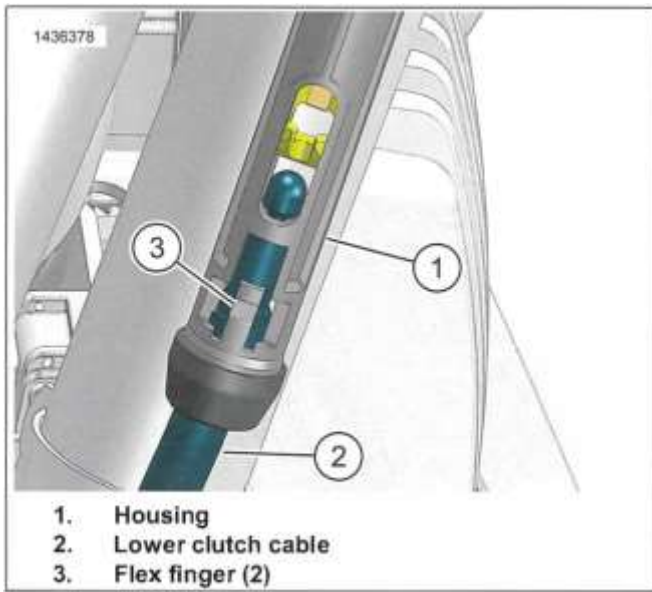
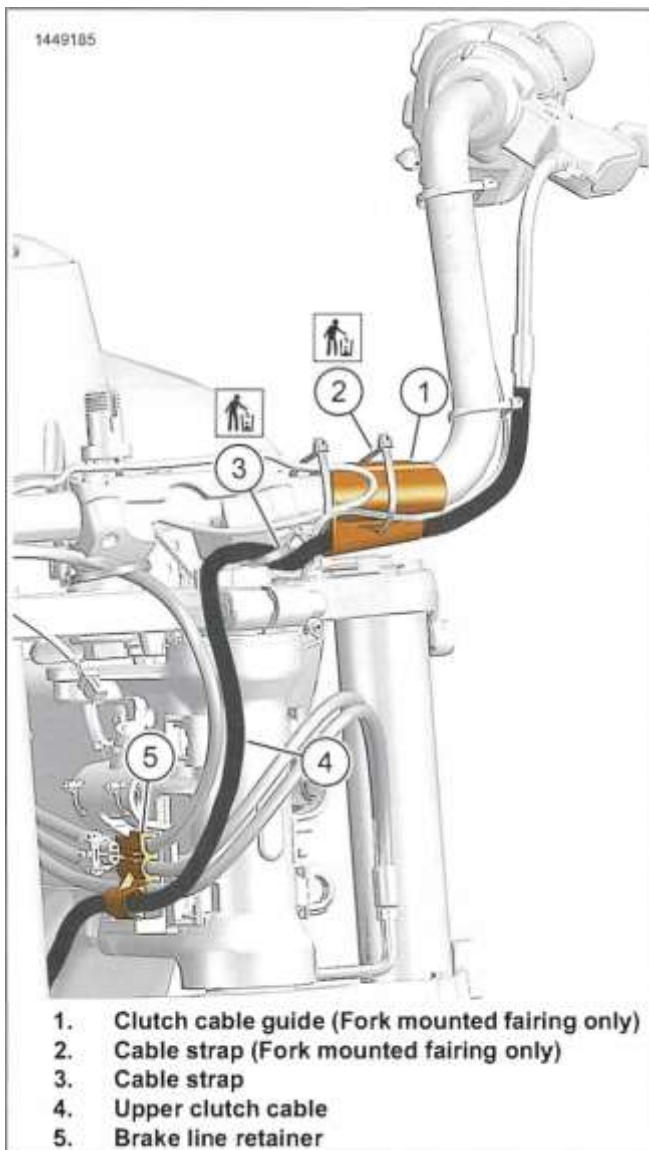


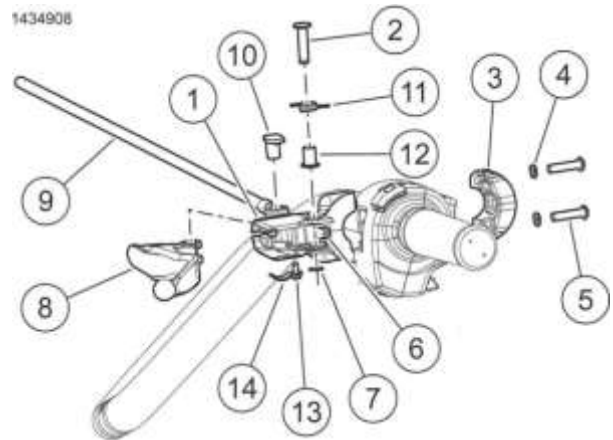
Figure 3-87. Lower Clutch Cable



1. Clutch cable guide (Fork mounted fairing only)
2. Cable strap (Fork mounted fairing only)
3. Cable strap
4. Upper clutch cable
5. Brake line retainer

Figure 3-88. Upper Clutch Cable Routing (Typical)

1. Clutch lever bracket
2. Pivot pin



3. Lever bracket clamp
4. Washer (2)
5. Screw (2)
6. Clutch switch
7. Retaining ring
8. Clutch hand lever
9. Clutch cable
10. Pin
11. Spring
12. Pivot bushing
13. Screw
14. Anti-rattle spring

Figure 3-89. Clutch Lever Mount

## DISASSEMBLE

### Lock Button

1. See Figure 3-82. Access two piece clutch cable.

#### NOTE

See Figure 3-92. Upper clutch cable (1) spring must be **uncompressed**.

- a. Remove spring clip (3).
- b. Remove clutch cable from upper clip (1).
- c. Remove small clip above cover.
- d. Slide cover (2) up.
2. Unlock upper clutch cable (1).
  - a. Push lock button tabs (2) slightly inboard and then down to disengage.
3. Remove lock button.

### Housing

1. Disconnect clutch cable. See Clutch Cable Disconnect in the this section.
2. Remove housing (4) from upper housing (3).

## Clutch Lever

1. See Figure 3-90. Disassemble clutch lever.
  - a. Push out pivot bushing (5).
  - b. Remove spring (1).
  - c. Remove screw (4).
  - d. Remove anti-rattle (3).

## ASSEMBLE

| FASTENER                       | TORQUE VALUE        |             |
|--------------------------------|---------------------|-------------|
| Clutch lever anti-rattle screw | 19-23 <b>in-lbs</b> | 2.1-2.6 N-m |

## Clutch Lever

1. See Figure 3-90. Assemble clutch lever.
  - a. Install anti-rattle (3).
  - b. Install screw (4). Tighten.  
Torque: 19-23 **in-lbs** (2.1-2.6 N-m) *Clutch lever anti-rattle screw*
  - c. Install spring (1) in hole in clutch lever (2).
  - d. Install pivot bushing (5) flush with bottom of clutch lever.

## Housing

1. See Figure 3-91. Align coupler guide (2) with the guide in housing.
2. See Figure 3-92. Install housing (4) to upper housing (3).
3. Connect clutch cable. See Clutch Cable Connect in this section.

## Lock Button

### NOTE

*Upper clutch cable (1) spring must be **uncompressed**.*

1. See Figure 3-92. Install lock button (2).
2. See Figure 3-82. Install cover.
  - a. Slide cover (2) down.
  - b. Install clutch cable in upper clip (1).
  - c. Install small clip above cover.
  - d. Install spring clip (3).

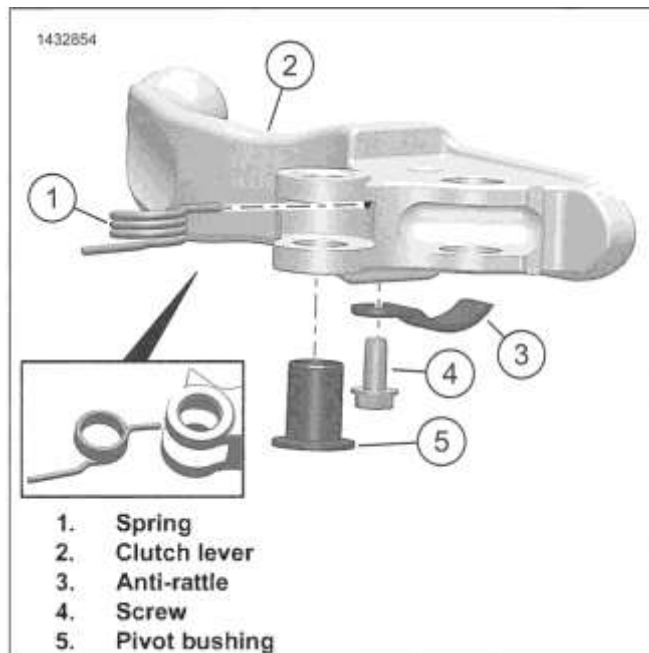


Figure 3-90. Clutch Components

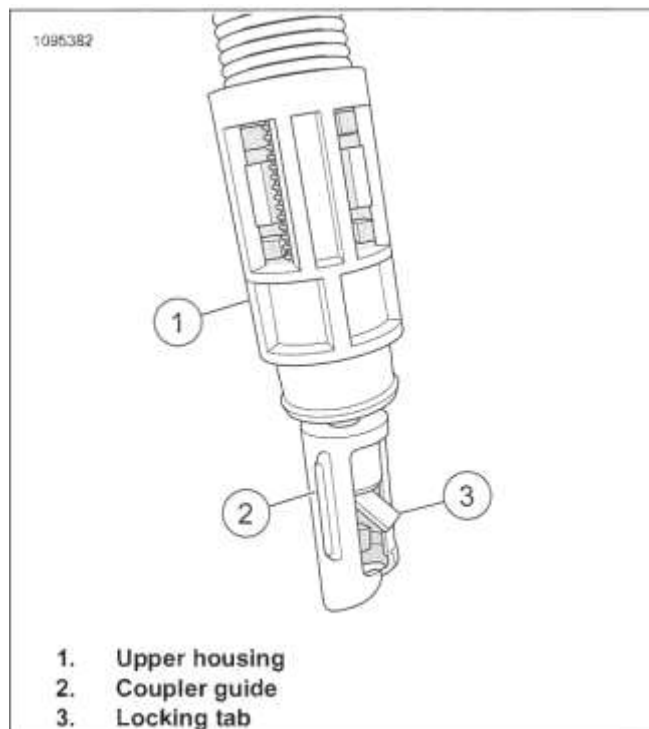
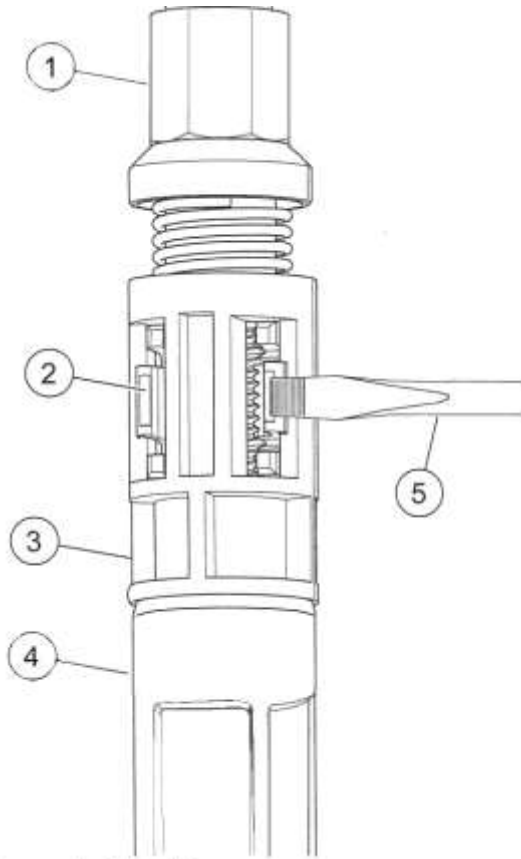


Figure 3-91. Upper Housing



**COMPLETE**

1. Install main fuse. See (Page 8-8). POWER DISCONNECT



1. Upper clutch cable
2. Lock button Upper housing Housing Screwdriver
- 3.
- 4.
- 5.

Figure 3-92. Upper Clutch Cable Compressed



## PREPARE

1. Remove windshield. See WINDSHIELD (Page 3-121).
2. Loosen acorn nuts. Do not remove acorn nuts now. Remove the auxiliary/fog lamp bracket. See
3. FLHP:
  - a. Remove acorn nuts securing speedometer bracket.  
Remove speedometer and hang over handlebar.
  - b. Remove nut securing audio jack (left side).
4. Remove screw securing the headlamp door (chrome ring). Remove the headlamp door.

| PART NUMBER | CONSUMABLE  |
|-------------|---|
| 99642-97    | LOCTITE 243 MEDIUM STRENGTH<br>THREADLOCKER AND SEALANT<br>(BLUE) |

**NOTE**

See Figure 3-93. Verify that trim strips (12) are installed to prevent chafing of the brake hose and/or handlebar switch wires.

<sup>1</sup> Install headlamp nacelle (8) housings on fork brackets. Install grommets. Start acorn nuts. Also secure clutch cable P-clamp on upper-left stud. If studs were removed:

- a. Install acorn nut on the stud end without locking agent. Install until stud is bottomed in nut.
- b. Install grommet on stud.
- c. Apply threadlocker to the threads of stud.

LOCTITE 243 MEDIUM STRENGTH  
THREADLOCKER AND SEALANT (BLUE) (99642-97)

- d. While holding nacelle housing in place, start stud/nut/grommet assembly in each hole.
- e. Install auxiliary/fog lamp bracket. Tighten.  
Torque: 96-132 in-lbs (10.8-14.9 N-m) *Headlamp nacelle stud/nut/grommet assembly FLHR/C*

## REMOVE

1. See Figure 3-93. Remove eight screws (10) to free the headlamp assembly (9).
2. Carefully pry off the fork lock plate (1). Remove two screws (2).
3. Loosen screw (3) until nut (5) and flat washer are near the end of screw.
4. Lift the handlebar clamp shroud (4). Pull rearward through the gap to remove shroud.
5. Remove acorn nuts, grommets and clutch cable P-clamp from the fork bracket studs.
6. See Figure 3-94. Disconnect accessory switch (1) and auxiliary/fog lamp switch (2) connectors.

**NOTE**

See ACCESSORY SWITCHES (Page 8-28) for nacelle switch replacement.

Remove the headlamp nacelle (8) housings.

**NOTE**

See Figure 3-93. If disassembled, install screw (3), flat washer and nut (5) on the handlebar clamp shroud (4).

Connect accessory switch and auxiliary/fog lamp switch connectors.

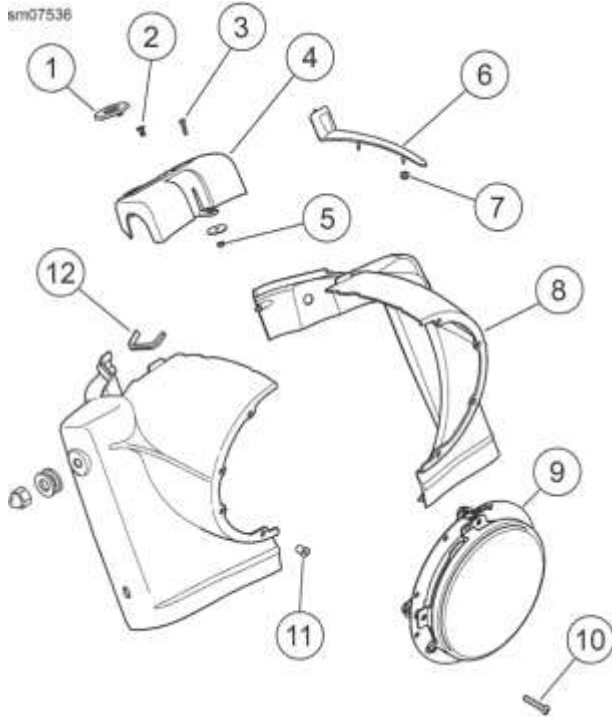
3. See Figure 3-93. Install the handlebar clamp shroud (4):
  - a. Slide the handlebar clamp shroud screw forward into the gap.
  - b. Position the shroud over the flange at the top of the nacelle.
  - c. Install screws (2).

## INSTALL

| FASTENER  | TORQUE VALUE  |               |
|---|---------------|---------------|
| Handlebar clamp shroud screw                      | 10-20 in-lbs  | 1.1-2.3 N-m   |
| Headlamp door screw                               | 9-18 in-lbs   | 1-2 N-m       |
| Headlamp mount to nacelle screw                   | 9-18 in-lbs   | 1-2 N-m       |
| Headlamp nacelle acorn nut FLHR/C                 | 96-132 in-lbs | 10.8-14.9 N-m |
| Headlamp nacelle chrome strip flange nut          | 15-20 in-lbs  | 1.7-2.3 N-m   |
| Headlamp nacelle stud/nut/grommet assembly FLHR/C | 96-132 in-lbs | 10.8-14.9 N-m |

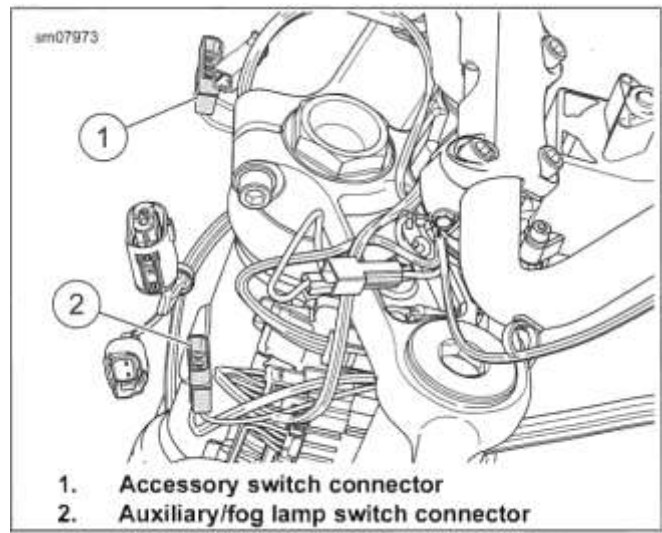
4. Tighten screws (2, 3).  
Torque: 10-20 in-lbs (1.1-2.3 N-m) *Handlebar clamp shroud screw*
5. Install fork lock plate (1).
6. Install chrome strip (6). Secure with flange nut (7). Tighten.  
Torque: 15-20 in-lbs (1.7-2.3 N-m) *Headlamp nacelle chrome strip flange nut*
7. Tighten acorn nuts.  
Torque: 96-132 in-lbs (10.8-14.9 N-m) *Headlamp nacelle acorn nut FLHR/C*

8. Connect headlamp connector.
9. Install headlamp assembly. Secure with eight screws (10).  
Tighten.  
Torque: 9-18 in-lbs (1-2 N-m) *Headlamp mount to nacelle screw*
10. Install headlamp door. Secure with screw and tighten.



Torque: 9-18 in-lbs (1-2 N-m) *Headlamp door screw*

1. Fork lock plate
  2. Screw (2)
  3. Screw
  4. Handlebar clamp shroud
  5. Nut
  6. Chrome strip
  7. Flange nut
  8. Nacelle
  9. Headlamp assembly
  10. Screw (8)
  11. Well nut (8)
  12. Trim strip
- Figure 3-93. Headlamp Nacelle Assembly



1. Accessory switch connector
2. Auxiliary/fog lamp switch connector

Figure 3-94. Nacelle Switch Connectors

### **COMPLETE**

| FASTENER                             | TORQUE VALUE  |              |
|--------------------------------------|---------------|--------------|
| Speedometer bracket acorn nuts: FLHP | 72-108 in-lbs | 8.1-12.2 N-m |

1. FLHP:
  - a. Install speedometer and bracket with acorn nuts. Tighten.  
Torque: 72-108 in-lbs (8.1-12.2 N-m) *Speedometer bracket acorn nuts: FLHP*
  - b. Install audio jack. Tighten securely.
2. Install the auxiliary/fog lamp bracket. Capture the clutch cable P-clamp on the upper left stud. See AUXILIARY LAMPS (Page 8-46).
3. Install windshield. See WINDSHIELD (Page 3-121).

## REMOVE AND INSTALL: WINDSHIELD

| FASTENER  | TORQUE VALUE        |             |
|---|---------------------|-------------|
| Outer fairing screws: Fork-mounted fairing models | 20-30 <b>in-lbs</b> | 2.3-3.4 N-m |
| Windshield screws: Fork-mounted fairing models    | 25-30 <b>in-lbs</b> | 2.8-3.4 N-m |

### Prepare

Remove main fuse. See POWER DISCONNECT (Page 8-8).

### Remove

- See Figure 3-95. Remove three screws (1,2) securing the windshield.
- Loosen two screws (3).
- Spread inner and outer fairing while removing windshield.

### Install

- Place windshield into position:
  - Spread inner and outer fairings at windshield opening.
  - Fit keyhole on one end of windshield over raised boss on inner fairing.
  - Fit center keyhole over center raised inner fairing boss.
  - Fit keyhole on opposite end of windshield over inner fairing raised boss.
- Tighten two screws (3).  
Torque: 20-30 **in-lbs** (2.3-3.4 N-m) *Outer fairing screws: Fork-mounted fairing models*
- See Figure 3-95. Install three screws (1,2). Tighten.  
Torque: 25-30 **in-lbs** (2.8-3.4 N-m) *Windshield screws: Fork-mounted fairing models*

### Complete

Install main fuse. See POWER DISCONNECT (Page 8-8).

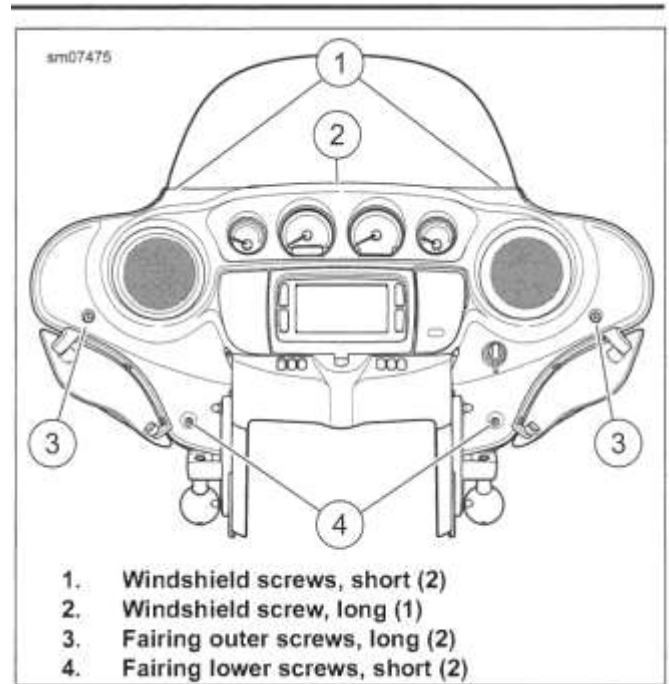


Figure 3-95. Outer Fairing Screws

## REMOVE AND INSTALL: OUTER FAIRING SHELL

| FASTENER                      | TORQUE VALUE        |             |
|-------------------------------|---------------------|-------------|
| Fork mounted fairing screw    | 20-30 <b>in-lbs</b> | 2.3-3.4 N-m |
| Fork mounted windshield screw | 25-30 <b>in-lbs</b> | 2.8-3.4 N-m |

### Prepare

Remove main fuse. See POWER DISCONNECT (Page 8-8).

### Remove

- Remove windshield. See Remove and Install: Windshield (Page 3-89).
- Loosely install center windshield screw to prevent fairing from unexpectedly falling.
- See Figure 3-96. Remove two screws (3).
- Remove two screws (4).
- Remove center windshield screw.
- Pull the outer fairing forward and separate headlamp connector [38].
- Remove outer fairing.

### Install

- Verify seals between outer and inner fairing are in good shape and in place.

#### NOTE

- Confirm that the correct screws are installed in each location.

- See Figure 3-96. Screws (4) are similar to the center screw that secures the windshield. Use care to avoid mixing them during installation. Screws (4) have a smooth shank, captive washer and unthreaded tip.

- Mate headlamp connector [38]. Install outer fairing.
- See Figure 3-96. Start two long screws (3).
- Start two short screws (4).
- Place windshield into position:
  - Spread inner and outer fairings at windshield opening.
  - Fit keyhole on one end of the windshield over raised boss on inner fairing.
  - Fit center keyhole over center raised inner fairing boss.
  - Fit keyhole on opposite end of windshield over inner fairing raised boss.
- Start three screws (1,2). Tighten.  
Torque: 25-30 **in-lbs** (2.8-3.4 N-m) *Fork mounted windshield screw*
- Tighten screws (3, 4).  
Torque: 20-30 **in-lbs** (2.3-3.4 N-m) *Fork mounted fairing screw*

### Complete

Install main fuse.

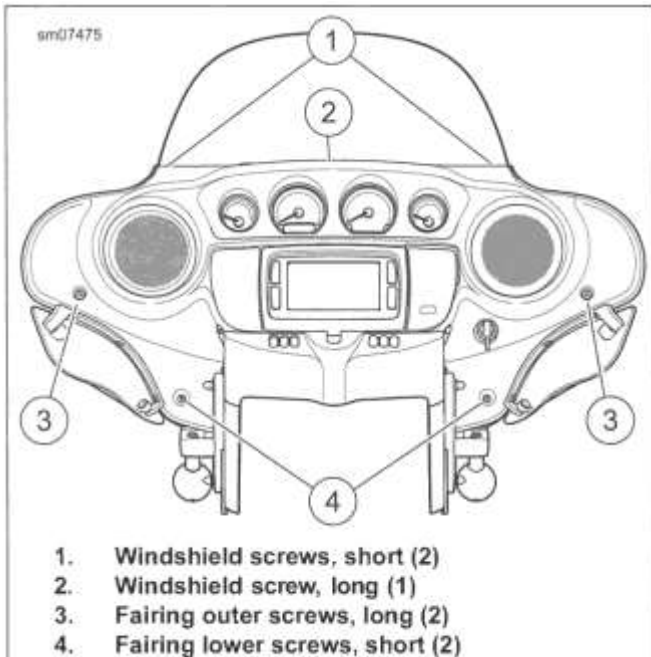


Figure 3-96. Outer Fairing Screws

### Install

- Install **new** trim. Use masking tape at the ends to hold in place on inner fairing during assembly.

### Complete

- Install outer fairing. See Remove and Install: Outer Fairing

## REMOVE AND INSTALL: PERIMETER TRIM

### Prepare

- Remove outer fairing. See Remove and Install: Outer Fairing Shell (Page 3-89).

### Remove

- Remove damaged trim.

Shell (Page 3-89).

## REMOVE AND INSTALL: GLOVEBOX

### Remove

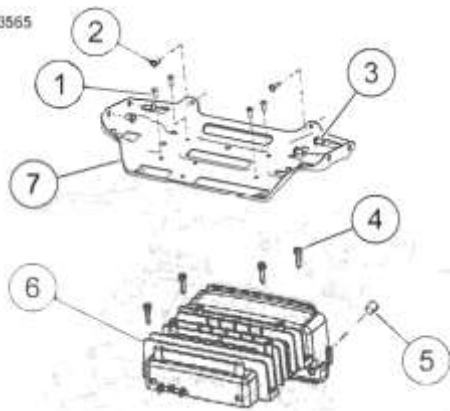
- Remove outer fairing. See Remove and Install: Outer Fairing Shell (Page 3-89).
- Remove dash panel. See Remove and Install: Dash Panel

| FASTENER   | TORQUE VALUE        |             |
|--|---------------------|-------------|
| Glovebox screw                                   | 60-84 <b>in-lbs</b> | 6.8-9.5 N-m |
| Upper support bracket to glovebox screw          | 2.0-3.0 ft-lbs      | 2.7-4 N-m   |
| Upper support bracket to inner fairing screw     | 0.8-1.6 ft-lbs      | 1.1-2.2 N-m |
| Upper support bracket to speaker enclosure screw | 4.0-5.0 ft-lbs      | 5.4-6.8 N-m |

(Page 3-92).

- Remove fairing vent bezel. See Remove and Install: Vent Bezel (Page 3-91).
- See Figure 3-97. Remove upper support bracket (7).
  - Remove four screws (3).
  - Remove two screws (2).
  - Remove four screws (1).
  - Remove upper support bracket (7).
- Remove glovebox (6).
  - Remove four screws (4).
  - Remove glovebox (6).
  - Remove plug (5).

1273565



1. Upper support-to-glovebox screw (4)
2. Upper support-to-inner fairing screw (2)
3. Upper support-to-speaker enclosure screw (4)
4. Screw, glovebox (4)
5. Plug
6. Glovebox
7. Upper support bracket

Figure 3-97. Glovebox

### Install

1. See Figure 3-97. Install glovebox (6).
  - a. Install plug (5).
  - b. Install glovebox (6).
  - c. Install four screws (4). Tighten.  
Torque: 60-84 in-lbs (6.8-9.5 N-m) *Glovebox screw*
2. Place upper support bracket (7) into position.
3. Loosely install screws (1-3).
4. Tighten screws in the following sequence for proper alignment:
  - a. Tighten screws (2).  
Torque: 0.8-1.6 ft-lbs (1.1-2.2 N-m) *Upper support bracket to inner fairing screw*
  - b. Tighten screws (3).  
Torque: 4.0-5.0 ft-lbs (5.4-6.8 N-m) *Upper support bracket to speaker enclosure screw*
  - c. Tighten screws (1).  
Torque: 2.0-3.0 ft-lbs (2.7-4 N-m) *Upper support bracket to glovebox screw*
5. Install vent bezel. See Remove and Install: Vent Bezel (Page 3-91).
6. Install dash panel. See Remove and Install: Dash Panel (Page 3-92).
7. Install outer fairing. See Remove and Install: Outer Fairing Shell (Page 3-89).

## REMOVE AND INSTALL: HEADLAMP ASSEMBLY

| FASTENER                         | TORQUE VALUE |             |
|----------------------------------|--------------|-------------|
| Fork mounted headlamp door screw | 9-18 in-lbs  | 1-2 N-m     |
| Fork mounted headlamp screw      | 22-32 in-lbs | 2.5-3.6 N-m |

### Remove

1. See Figure 3-98. Remove headlamp door (4). If needed, remove headlamp from mount (2). See HEADLAMP (Page 8-41).
2. Remove screws (3).
3. Hold headlamp and mount (2) away from fairing and disconnect wiring harness.
4. Remove headlamp trim (1).

### Install

1. Connect wiring harness to headlamp.
2. See Figure 3-98. Install headlamp trim and mount with four screws (3). Tighten.  
Torque: 22-32 in-lbs (2.5-3.6 N-m) *Fork mounted headlamp screw*
3. Install headlamp door (4) with screw (5). Tighten.  
Torque: 9-18 in-lbs (1-2 N-m) *Fork mounted headlamp door screw*

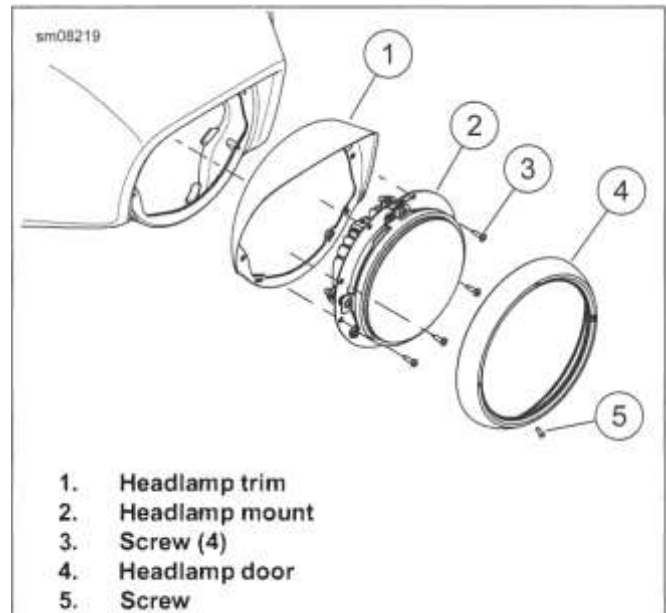


Figure 3-98. Headlamp Mount

## REMOVE AND INSTALL: VENT BEZEL

### Prepare

1. Remove outer fairing. See Remove and Install: Outer Fairing Shell (Page 3-89).

## Remove

- See Figure 3-99. From inside fairing, use a putty knife to release adhesive (2).
- Release latches (1). Remove bezel.
- Remove old adhesive from fairing.
  - Clean areas with rubbing alcohol.
  - Allow to dry completely.

## Install

- Install **new** bezel. Apply pressure to adhesive areas for 10 seconds.

## Complete

- Install outer fairing. See Remove and Install: Outer Fairing Shell (Page 3-89).

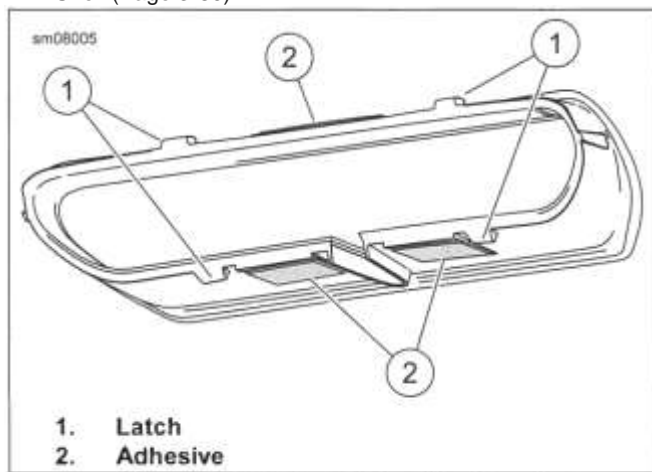


Figure 3-99. Outer Fairing Vent Bezel

## REMOVE AND INSTALL: DASH PANEL

| FASTENER                      | TORQUE VALUE        |             |
|-------------------------------|---------------------|-------------|
| Fork mounted dash panel screw | 25-30 <b>in-lbs</b> | 2.8-3.4 N-m |

## Prepare

- Remove ignition switch knob and spring. Remove nut and collar from ignition switch. See IGNITION SWITCH (Page 8-16).

## Remove

- See Figure 3-100. Remove two screws (1) (with flat washers) to release dash panel.
- Lift dash panel and disconnect dash panel switch connectors (2).
- Remove dash panel.
- See ACCESSORY SWITCHES (Page 8-28) for switch service.

## Install

- See Figure 3-100. Mate switch connectors (2).
- Install dash panel over ignition switch housing.
- Install two screws (1) (with flat washers) to secure dash panel. Tighten.
 

Torque: 25-30 **in-lbs** (2.8-3.4 N-m) *Fork mounted dash panel screw*

## Complete

- Install nut and collar to ignition switch. Install ignition switch knob and spring. See IGNITION SWITCH (Page 8-16).

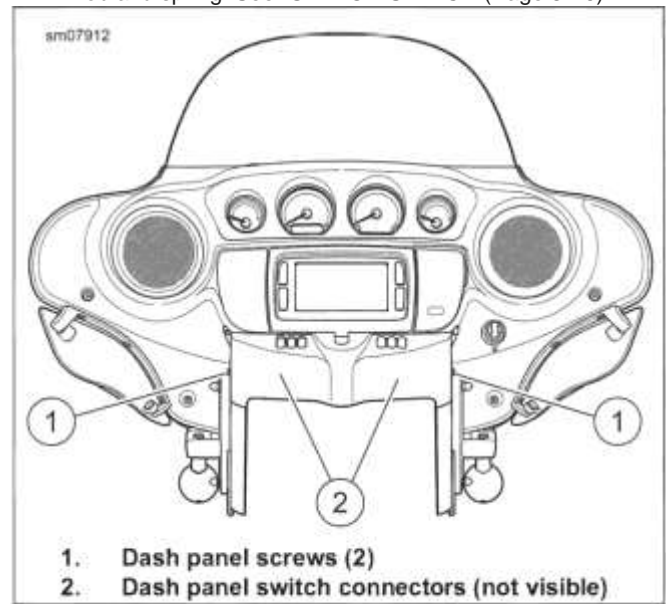


Figure 3-100. Dash Panel Screws

## DETACH FAIRING FOR SERVICE

| FASTENER                               | TORQUE VALUE          |               |
|--|-----------------------|---------------|
| Fork mounted inner fairing double stud | 120-180 <b>in-lbs</b> | 13.6-20.3 N-m |

## Prepare

- Remove auxiliary/fog lamp brackets or turn signal brackets. See AUXILIARY LAMPS (Page 8-46).
- Remove outer fairing. See Remove and Install: Outer Fairing Shell (Page 3-89).
- See Figure 3-143. Disconnect TGS connector (14).
- Remove dash panel. See Remove and Install: Dash Panel (Page 3-92).

## Detach

- NOTE**

Rotate inner fairing to perform repairs such as ignition switch replacement, handlebar replacement or to access harnesses and lines that are attached to the handlebar. Rotate only as far as needed to make repair. Over-rotation can result in cosmetic damage.



The area below radio opening may contact the ignition switch stem. Use care to avoid cosmetic damage. Place a rag or other protection between stem and inner fairing.

See Figure 3-101. Remove double studs (2).

2. Remove chrome skirt (3).

3. **NOTE**

- Disconnection of other electrical components is not necessary
- Over rotation of fairing can result in cosmetic damage. Rotate fairing only enough to access the components needing service.

Lift inner fairing assembly slightly and rotate upper portion forward until it is approximately vertical.

### Attach

1. Lift inner fairing slightly and rotate back into position.

2. See Figure 3-143. Connect TGS connector (14).

3. Install chrome skirt.

4. Install double studs. Tighten.

Torque: 120-180 in-lbs (13.6-20.3 N-m) *Fork mounted inner fairing double stud*

### Complete

1. Install dash panel. See Remove and Install: Dash Panel (Page 3-92).

2. Install outer fairing and auxiliary/fog lamp brackets or turn signal brackets. See Remove and Install: Outer Fairing Shell (Page 3-89).

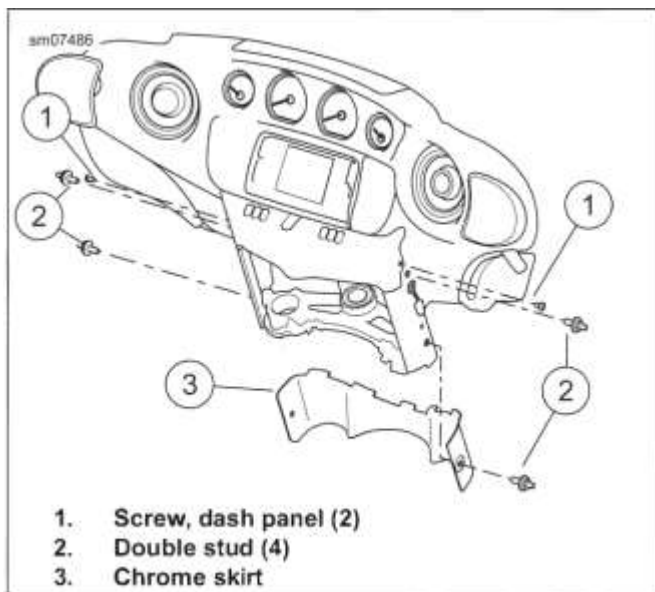


Figure 3-101. Inner Fairing Fasteners

| FASTENER                                      | TORQUE VALUE |             |
|---|--------------|-------------|
| Fairing speaker enclosure to fairing screws   | 48-60 in-lbs | 5.4-6.8 N-m |
| Fairing speaker grille screws                 | 9-13 in-lbs  | 1-1.5 N-m   |
| Gauges, 2-inch diameter gauge screws          | 8-15 in-lbs  | 0.9-1.7 N-m |
| Gauges, instrument cluster screws             | 10-20 in-lbs | 1.1-2.3 N-m |
| Media compartment screw, lower                | 8-12 in-lbs  | 0.9-1.3 N-m |
| Power outlet, front                           | 13-17 in-lbs | 1.5-1.9 N-m |
| Upper support bracket to inner fairing screws | 10-19 in-lbs | 1.1-2.2 N-m |

### REMOVE AND INSTALL: FAIRING

#### Prepare

#### NOTE

Cover painted parts to protect finish.

1. Remove air deflectors. See AIR DEFLECTORS (Page 3-119).
2. Remove outer fairing. See Remove and Install: Outer Fairing Shell (Page 3-89).
3. Remove inner fairing assembly. See Remove and Install: Inner Fairing Shell (Page 3-95).
4. Remove fairing vent. See Remove and Install: Vent (Page 3-96).

#### Remove

#### NOTE

Never lift the fairing assembly by the radio face.

1. Disconnect harness connectors from gauges and instrument cluster.
2. Pull harness anchors from 2-inch gauges.
3. See Figure 3-102. Remove two upper support screws (2).
4. Remove four enclosure screws (1).
5. Disconnect connectors (4, 5).
6. See Figure 3-105. Remove two lower enclosure screws (2).
7. See Figure 3-102. Remove media compartment screw (6).

#### NOTE

Use caution when lifting fairing from support structure assembly to prevent speaker damage.

Lift inner fairing shell off support structure assembly.

9. See Figure 3-103. Remove screws to release 2-inch gauges (1) and instrument cluster (2).

10. Remove screws to release speaker grilles (3).

11. **NOTE**

*Media compartment door must be open to remove or install media compartment.*

Remove screw (4) to release media compartment.

12. Remove power outlet (5).

13. Remove left and right edge seals.

14. **FLHX, FLHXS:** Remove mirrors. See MIRRORS (Page 3-132).

**Install**

1. **FLHX, FLHXS:** Install mirrors. See MIRRORS (Page 3-132).

2. See Figure 3-103. Install power outlet (5). Tighten. Torque: 13-17 **in-lbs** (1.5-1.9 N-m) *Power outlet, front*

3. Verify that media compartment door is open. Install media compartment. Tighten screw (4).

Torque: 8-12 **in-lbs** (0.9-1.3 N-m) *Media compartment screw, lower*

4. Install speaker grilles (3) with arrows aligned with those on the inner fairing. Tighten.

Torque: 9-13 **in-lbs** (1-1.5 N-m) *Fairing speaker grille screws*

5. Install 2-inch gauges (1). Tighten.

Torque: 8-15 **in-lbs** (0.9-1.7 N-m) *Gauges, 2-inch diameter gauge screws*

6. Install instrument cluster (2) using single screw at top. Tighten.

Torque: 10-20 **in-lbs** (1.1-2.3 N-m) *Gauges, instrument cluster screws*

7. See Figure 3-104. Place support structure assembly on the work surface with the tops of the speaker enclosures (2) near the edge of the work surface (1).

8. See Figure 3-105. Place inner fairing onto structure assembly. Adjust position so the protrusions at the top of the fairing hang off the edge of the work surface. Start lower speaker enclosure screws (2).

9. See Figure 3-102. Install two screws (2). Tighten.

Torque: 10-19 **in-lbs** (1.1-2.2 N-m) *Upper support bracket to inner fairing screws*

10. Install four screws (1). Tighten screws (1,3).

Torque: 48-60 **in-lbs** (5.4-6.8 N-m) *Fairing speaker enclosure to fairing screws*

11. Install media compartment screw (6).

12. Install connectors (4, 5).

13. Install harness connectors to the gauges and instrument cluster. Install harness anchors to the 2-inch gauges.

14. Install left and right edge seals.

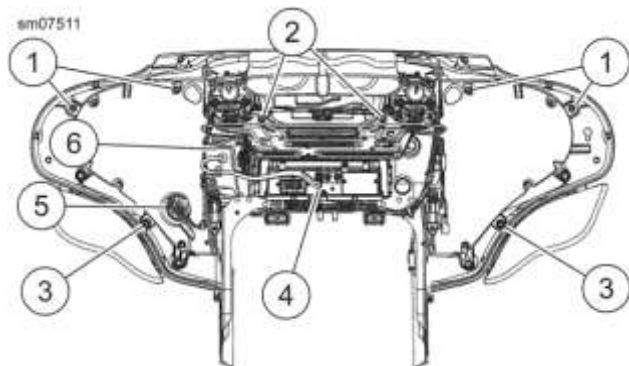
**Complete**

1. Install fairing vent. See Remove and Install: Vent (Page 3-96).

2. Install inner fairing assembly. See Remove and Install: Inner Fairing Shell (Page 3-95).

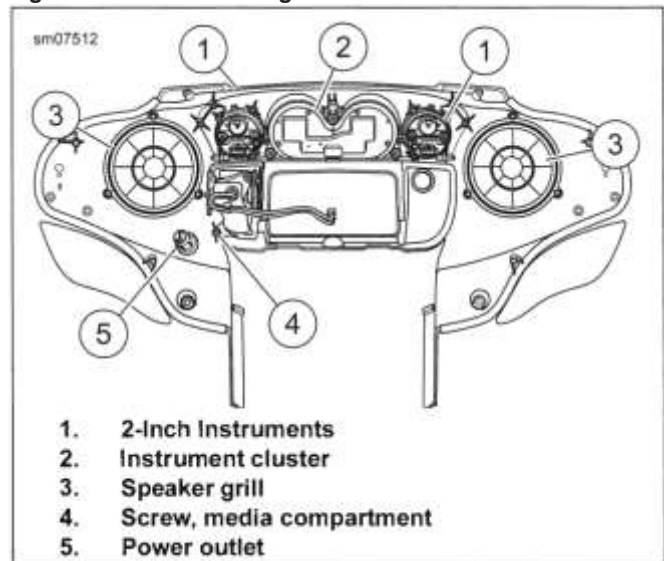
3. Install outer fairing. See Remove and Install: Outer Fairing Shell (Page 3-89).

4. Install air deflectors. See AIR DEFLECTORS (Page 3-119).



- 1. **Screw, speaker enclosure**
- 2. **Screw, upper support**
- 3. **Screw, enclosure, lower**
- 4. **Media cable connector**
- 5. **Power outlet connector**
- 6. **Screw, media compartment**

**Figure 3-102. Inner Fairing**



- 1. **2-Inch Instruments**
- 2. **Instrument cluster**
- 3. **Speaker grille**
- 4. **Screw, media compartment**
- 5. **Power outlet**

**Figure 3-103. Support Structure Removed**

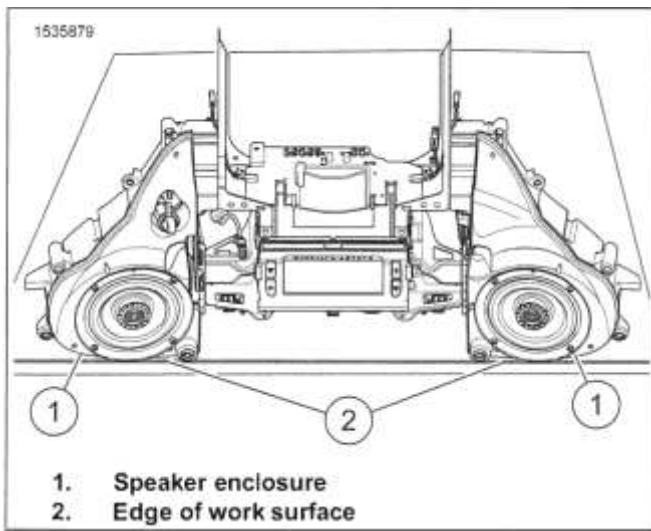
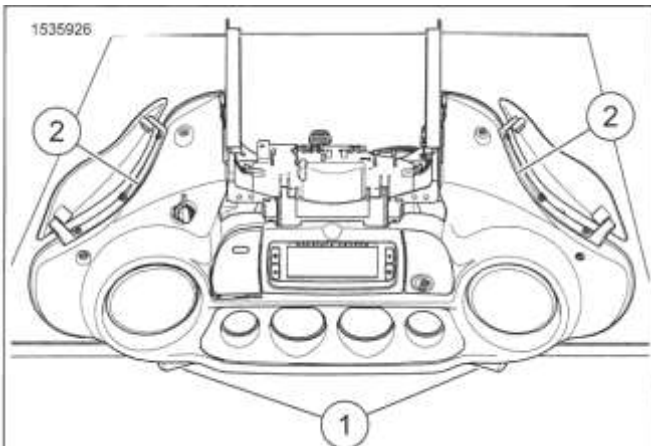


Figure 3-104. Support Structure Assembly



1. Protrusions at top of fairing
2. Lower speaker enclosure screws (not visible)

Figure 3-105. Inner Fairing Assembly

**REMOVE AND INSTALL: INNER FAIRING SHELL**

| FASTENER                               | TORQUE VALUE                  |
|--|-------------------------------|
| Fork mounted inner fairing double stud | 120-180 in-lbs 113.6-20.3 N-m |

**Prepare**

1. Remove outer fairing. See Remove and Install: Outer Fairing Shell (Page 3-89).

**Remove**

**NOTE**

Remove the inner fairing as an assembly to perform repairs such as handlebar replacement, fork bracket

repair/replacement, steering head bearing adjustment/replacement and so forth.

1. See Figure 3-106. Separate connectors (1-15, 18).
2. Release connector anchors on connectors (1, 2, 8, 14, 18).
3. Remove dash panel. See Remove and Install: Dash Panel (Page 3-92).
4. See Figure 3-101. Remove double studs (2).
5. Remove chrome skirt (3).
6. **NOTE**

The lower radio bezel may contact the ignition switch stem. Use care to avoid cosmetic damage. Place a rag or other protection between stem and radio bezel.

Pull both auxiliary/fog lamp connectors through the openings and into area of the inner fairing.

7. Roll top of fairing assembly forward while lifting to remove.

**Install**

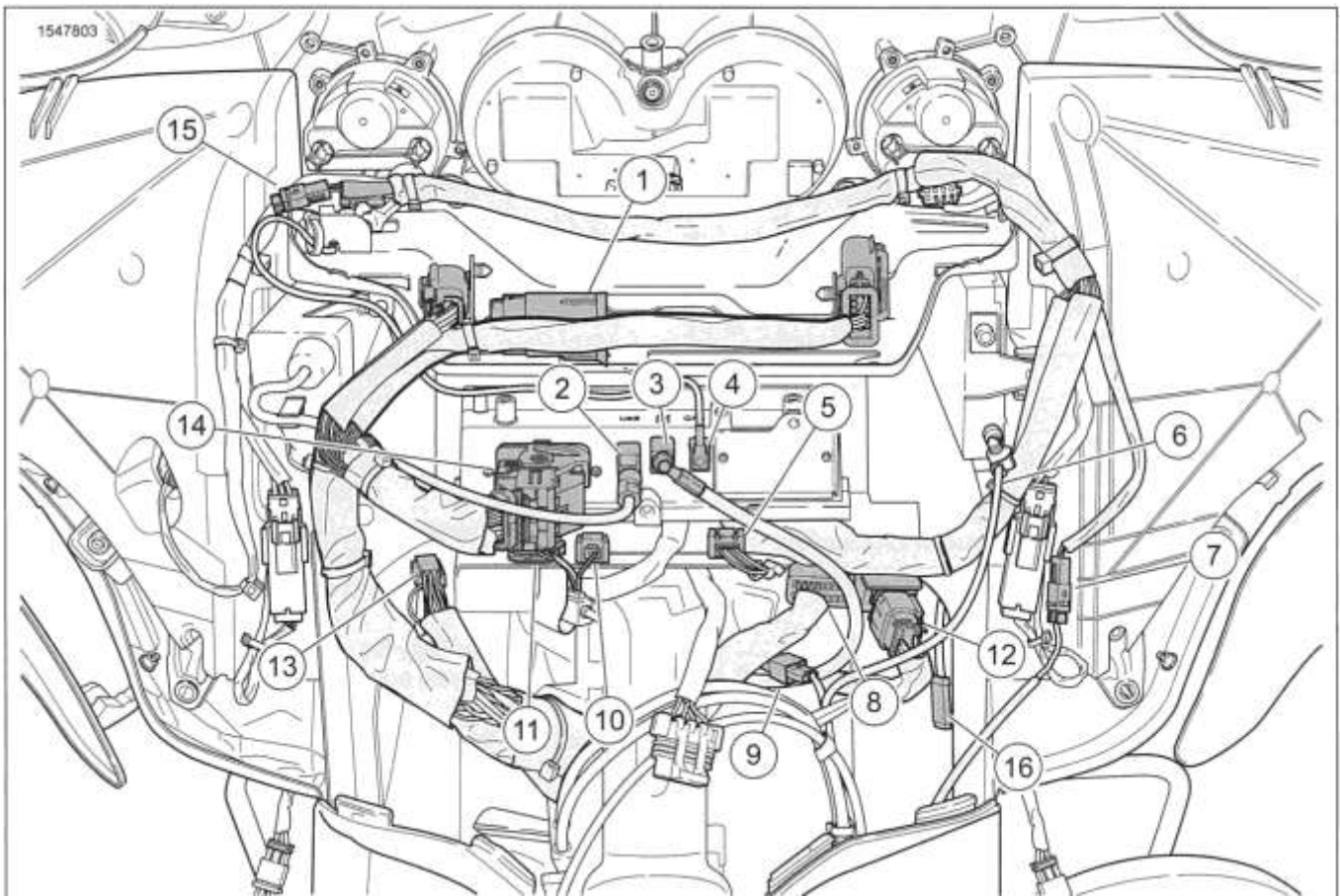
**NOTE**

Before installation, confirm that dash panel switch harnesses are routed back between handlebar and upper fork bracket.

1. Slide lower fairing support brackets over bosses on upper fork bracket. Roll top of fairing assembly rearward while lowering into position.
2. See Figure 3-101. Install chrome skirt (3).
3. Install double studs (2). Tighten.  
Torque: 120-180 in-lbs (13.6-20.3 N-m) Fork mounted inner fairing double stud
4. Install dash panel. See Remove and Install: Dash Panel (Page 3-92).
5. See Figure 3-106. Mate connectors (1-15, 18).
6. Secure connector anchors on connectors (1,2, 8, 14, 18).

**Complete**

1. Install outer fairing. See Remove and Install: Outer Fairing Shell (Page 3-89).



- |   |  |
|---|--|
| <ol style="list-style-type: none"> <li>1. P&amp;A audio</li> <li>2. USB cable</li> <li>3. AM/FM radio antenna</li> <li>4. GPS antenna</li> <li>5. Left handlebar switch harness</li> <li>6. CB antenna, if equipped</li> <li>7. Front fender tip lamp, if equipped</li> <li>8. Main-to-fairing harness, left</li> </ol> | <ol style="list-style-type: none"> <li>9. Ground</li> <li>10. Run/stop switch</li> <li>11. Right handlebar switch harness</li> <li>12. Main-to-fairing harness, right</li> <li>13. TGS</li> <li>14. Radio</li> <li>15. Accessory power</li> <li>16. Heated hand grip power, if equipped</li> </ol> |
|---|--|

Figure 3-106. Inner Fairing Harness Connectors: Fork Mounted Fairing

**REMOVE AND INSTALL: VENT**

Remove

**NOTE**

Never use cleaners containing chlorine or ammonia on plastic parts.

- Chlorine causes parts to become distorted and brittle resulting in cracks.
- Ammonia causes cloudiness and brittleness in windshields and forms a white haze on non-painted plastic parts.

1. Using mild soapy water and a soft brush, remove dirt, leaves and bugs from vent duct.

**Prepare**

1. Remove outer fairing. See Remove and Install: Outer Fairing Shell (Page 3-89)

| FASTENER   | TORQUE VALUE |             |
|--|--------------|-------------|
| Fairing vent to inner fairing:<br>fork mounted fairing | 20-30 in-lbs | 2.3-3.4 N-m |

**Cleaning**

1. Remove screws from either end of vent.
2. Remove vent.

**Install**

1. Install vent.
2. Install screws to each end of vent. Tighten.

Torque: 20-30 **in-lbs** (2.3-3.4 N-m) *Fairing vent to inner fairing: fork mounted fairing*

**Complete**

1. Install outer fairing. See Remove and Install: Outer Fairing Shell (Page 3-89).

**DISASSEMBLE AND ASSEMBLE: VENT**

| FASTENER                             | TORQUE VALUE        |             |
|--------------------------------------|---------------------|-------------|
| Vent assembly to inner fairing screw | 20-30 <b>in-lbs</b> | 2.3-3.4 N-m |

## Prepare

1. Remove vent assembly from inner fairing. See Remove and Install: Vent (Page 3-96).

## Disassemble

1. See Figure 3-107. Carefully pry between housing (3) and bezel (1) at each of the ten retainer clip (2) locations. Remove bezel.
2. Replace damaged or missing clips (2).
3. Remove all gasket material and adhesive.

## Assemble

1. See Figure 3-107. Install gasket.
  - a. Clean contact area with rubbing alcohol.
  - b. Install **new** foam gasket (4) along raised area of housing.
2. Install bezel (1). Verify all clips (2) are engaged.

## Complete

1. Install vent assembly to inner fairing. Tighten.

Torque: 20-30 **in-lbs** (2.3-3.4 N-m) *Vent assembly to inner fairing screw*



Figure 3-107. Fairing Vent Assembly

## REMOVE AND INSTALL: UPPER SUPPORT BRACKET

| FASTENER  | TORQUE VALUE        |             |
|---|---------------------|-------------|
| Media compartment screw, upper                      | 25-35 <b>in-lbs</b> | 2.8-4 N-m   |
| Upper support bracket to inner fairing screws       | 10-19 <b>in-lbs</b> | 1.1-2.2 N-m |
| Upper support bracket to radio (storage box) screws | 25-35 <b>in-lbs</b> | 2.8-4 N-m   |

| FASTENER  | TORQUE VALUE        |             |
|---|---------------------|-------------|
| Upper support bracket to speaker enclosure screws | 48-60 <b>in-lbs</b> | 5.4-6.8 N-m |

## Prepare

1. Remove outer fairing. See Remove and Install: Outer Fairing Shell (Page 3-89).
2. Remove fairing vent. See Remove and Install: Vent (Page 3-96).
3. Remove electrical connector anchors from support bracket.
4. If equipped, disconnect GPS antenna connector from radio.

## Remove

### NOTE

*Never operate vehicle with the radio or upper support bracket removed. These components provide important structural support to the fairing. Temporarily install the Police glove box assembly if the vehicle must be operated while the radio is removed. Damage to the fairing assembly can result if operated without either of these components installed.*

1. See Figure 3-108. Remove four screws (1).
2. Remove two screws (2).
3. Remove four screws (3).
4. Remove screw (6) securing media compartment.
5. Remove upper support bracket (4).

## Install

1. See Figure 3-108. Place upper support bracket (4) into position.
2. Loosely install screws (1-3).
3. Tighten screws in the following sequence for proper alignment:
  - a. Tighten screws (2).  
Torque: 10-19 **in-lbs** (1.1-2.2 N-m) *Upper support bracket to inner fairing screws*
  - b. Tighten screws (1).  
Torque: 48-60 **in-lbs** (5.4-6.8 N-m) *Upper support bracket to speaker enclosure screws*
  - c. Install four screws (3). Tighten.  
Torque: 25-35 **in-lbs** (2.8-4 N-m) *Upper support bracket to radio (storage box) screws*
4. Install screw (6). Tighten.  
Torque: 25-35 **in-lbs** (2.8-4 N-m) *Media compartment screw, upper*

## Complete

1. Secure electrical connector anchors to upper support.
2. Mate GPS antenna connector, if removed.
3. Install fairing vent. See Remove and Install: Vent (Page 3-96).
4. Install outer fairing. See Remove and Install: Outer Fairing Shell (Page 3-89).

## REMOVE AND INSTALL: MEDIA COMPARTMENT

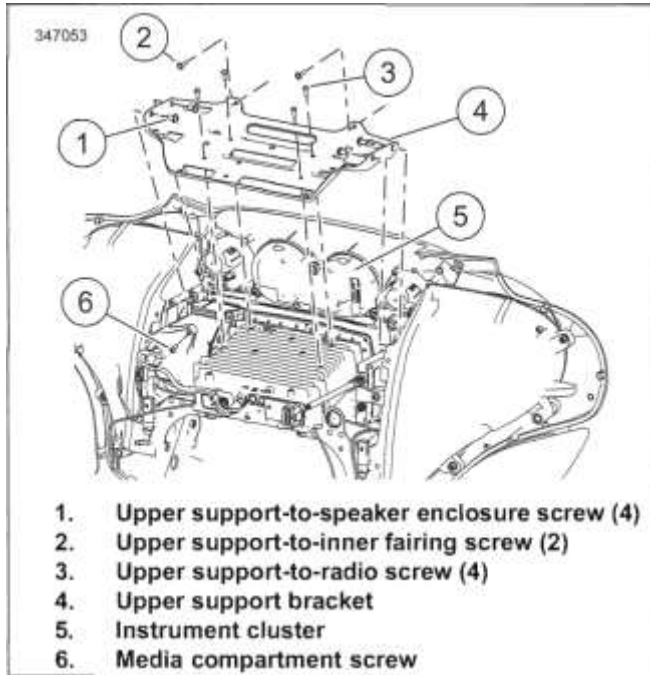


Figure 3-108. Upper Support Bracket

| FASTENER                       | TORQUE VALUE |           |
|--------------------------------|--------------|-----------|
| Media compartment screw, lower | 8-12in-lbs   | 0.9-1.3Nm |

## Prepare

1. Remove outer fairing. See Remove and Install: Outer Fairing Shell (Page 3-89).
2. Remove fairing vent. See Remove and Install: Vent (Page 3-96).
3. Remove upper support bracket. See Remove and Install: Upper Support Bracket (Page 3-97).

## Remove

*Never operate vehicle with the radio or upper support bracket removed. These components provide important structural support to the fairing. Temporarily install the Police glove box assembly if the vehicle must be operated while the radio is removed. Damage to the fairing assembly can result if operated without either of these components installed.*

## Replace Cable

### NOTE

1. Separate media cable connector from radio.
2. See Figure 3-109. Remove screw (4).
3. Open compartment door and remove media compartment.

## Install

1. See Figure 3-109. Place media compartment into position.
2. Install screw (4). Tighten.  
Torque: 8-12 **in-lbs** (0.9-1.3 N-m) *Media compartment screw, lower*
3. Mate media cable connector to radio.

## Complete

1. Install upper support bracket. See Remove and Install: Upper Support Bracket (Page 3-97).
2. Install fairing vent. See Remove and Install: Vent (Page 3-96).
3. Install outer fairing. See Remove and Install: Outer Fairing Shell (Page 3-89).

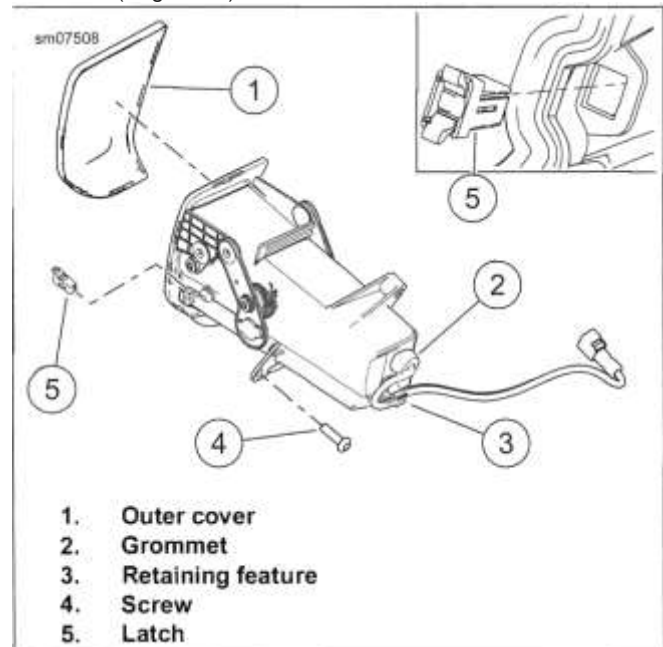


Figure 3-109. Media Compartment

## DISASSEMBLE AND ASSEMBLE: MEDIA COMPARTMENT

### NOTE

*This procedure can be performed with media compartment installed.*

1. Remove outer fairing. See Remove and Install: Outer Fairing Shell (Page 3-89).
2. See Figure 3-110. Separate media cable connector from radio.

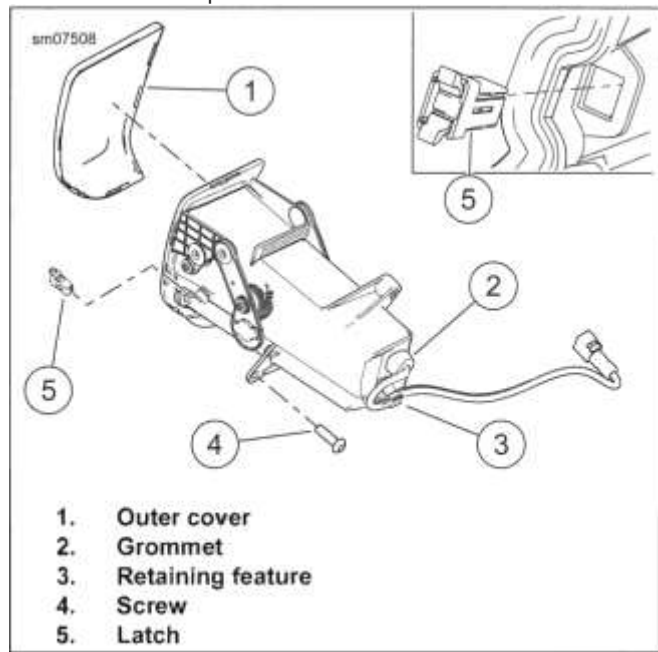
3. Remove cable from retaining feature (3).
4. Remove foam insert.
5. Push cable grommet (2) into media compartment to remove.
6. *NOTE*

*Apply small amount of window cleaner to aid installation.*

Route cable through mounting hole from inside compartment.

7. Pull grommet into hole until seated. Secure cable to retaining feature (3).
8. Install foam insert.
9. Connect media cable connector to radio.
10. Install outer fairing. See Remove and Install: Outer Fairing Shell (Page 3-89).

6. Install media compartment.



**Figure 3-110. Media Compartment**

### Replace Cover

#### *NOTE*

*This procedure can be performed with media compartment installed. Use care to avoid cosmetic damage.*

1. See Figure 3-110. Use a thin putty knife between the inner and outer (1) covers. Carefully pry outer cover off.
2. Align outer cover and install to inner cover.

### Replace Latch

1. Remove media compartment.
2. See Figure 3-110. Release upper and lower catches on latch (5).
3. Push latch out of housing.
4. Install **new** latch (5). Verify that catches are securely hooked.
5. Close and open door to verify operation.



## REMOVE AND INSTALL: WINDSHIELD

| FASTENER  | TORQUE VALUE |             |
|---|--------------|-------------|
| Windshield screws: Frame mounted fairing models | 8-12 in-lbs  | 0.9-1.4 N-m |

### Remove

1. Remove four screws securing windshield.
2. Remove windshield.

### Install

1. Verify windshield seal is in place on air duct assembly and not damaged.
2. Install windshield with four screws. Tighten.  
Torque: 8-12 in-lbs (0.9-1.4 N-m) *Windshield screws: Frame mounted fairing models*

4. Install vent assembly by engaging tabs in inner fairing. Align retainers and push down to secure.

## REMOVE AND INSTALL: UPPER VENT

### NOTE

| FASTENER                       | TORQUE VALUE |             |
|--------------------------------|--------------|-------------|
| Top vent door mechanism screws | 6-8 in-lbs   | 0.7-0.9 N-m |

*The vent housing, door and pins are not serviced. Replace assembly upon failure.*

### Remove

1. Remove windshield. See Remove and Install: Windshield in this section.
2. Pull up sharply on front edge of air vent housing to release two retainers.
3. Pull forward to remove air vent.
4. Windshield seal replacement:
  - a. Remove old windshield seal.  
  
Install new windshield seal, pulling each retaining tab through vent housing until each snap engages.
  - b.

### Install

1. See Figure 3-112. Replace damaged or missing retainers (2).
2. Verify windshield seal is in place on duct assembly and not damaged.
3. Verify foam strip is in place on upper flange of outer fairing.

5. Install windshield. See Remove and Install: Windshield in this section.

## Cleaning Air Vent

Occasional cleaning of air vent, door and button provides trouble-free operation.

### NOTE

*Never use cleaners containing chlorine or ammonia on plastic parts.*

- *Chlorine causes parts to become distorted and brittle resulting in cracks.*
  - *Ammonia causes cloudiness and brittleness in windshields and forms a white haze on unpainted plastic parts.*
1. With button in UP position (vent door closed), spray clean water into area under button.
  2. Spray low-pressure air in the same direction.
  3. Using mild soapy water and a soft brush, remove dirt and bugs from air duct and vent door.
  4. Operate vent and repeat cleaning as necessary.

## Repair Button Mechanism

1. Remove vent assembly.
2. See Figure 3-112. With latch released, remove screws (4). Remove button mechanism (6) as an assembly.
3. Inspect spring (3) and other components for damage. Clean residue from gear teeth.

### 4. NOTE

*Latch (5) is not symmetrical. A raised feature (arrow) on the housing prevents improper installation.*

Latch replacement:

- a. Release catches on latch (5).
  - b. Push latch out of housing.
  - c. See inset. Install new latch. Verify catches are securely hooked.
5. Install mechanism:
    - a. Disconnect spring (3).
    - b. See inset. With latch released, align the first tooth of button gear between first two teeth of vent door gear while lowering button mechanism into place.
    - c. Install screws (4) to hold mechanism in place.
    - d. Connect spring (3).

6. Install screws. Tighten.

Torque: 6-8 **in-lbs** (0.7-0.9 N-m) *Top vent door mechanism screws*

7. Verify mechanism operates correctly.

8. Install vent assembly.

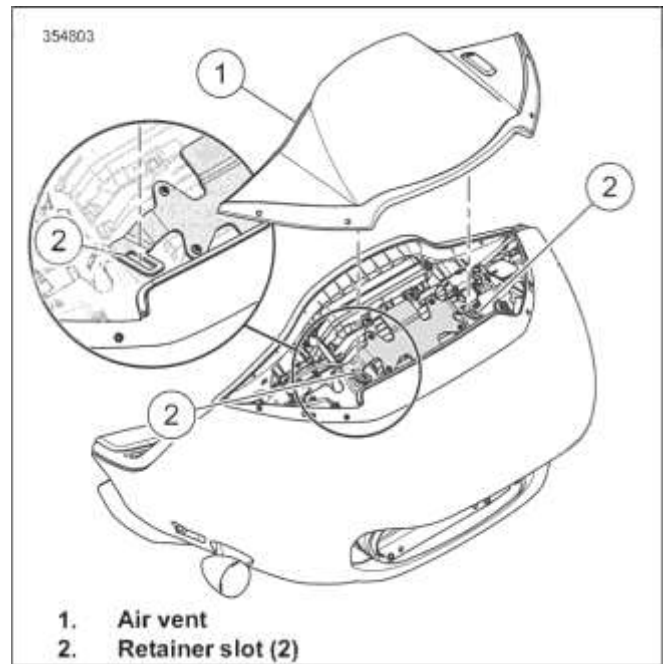


Figure 3-111. Top Air Vent

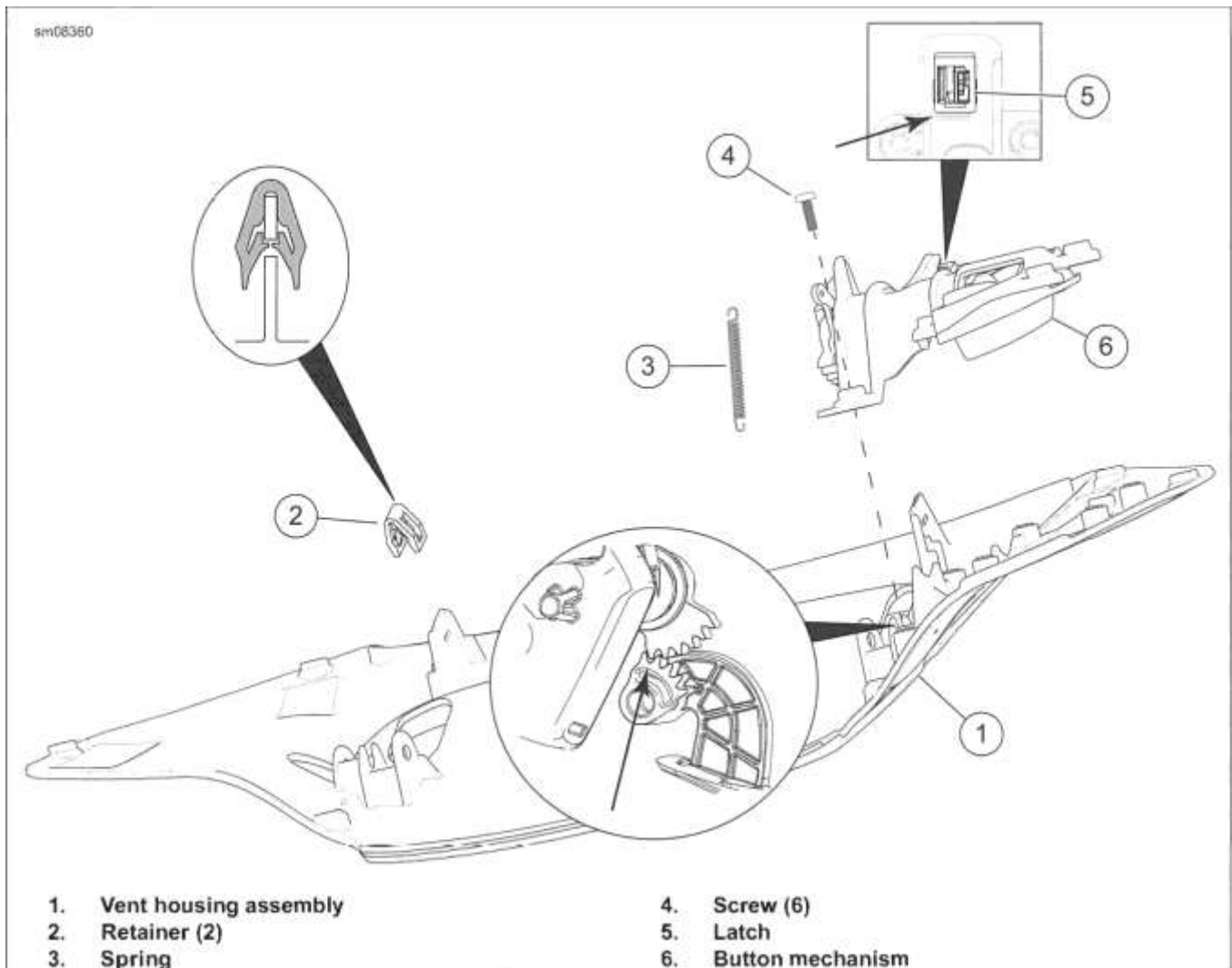


Figure 3-112. Top Air Vent Assembly

## REMOVE AND INSTALL: OUTER FAIRING SHELL

| FASTENER   | TORQUE VALUE |             |
|--|--------------|-------------|
| Outer fairing lower screws (also air deflector): frame mounted fairing | 8-15 in-lbs  | 0.9-1.7 N-m |
| Outer fairing upper screws (near speakers): frame mounted fairing      | 20-30 in-lbs | 2.3-3.4 N-m |
| Turn signal lamp mounting screw, front: frame mounted fairing          | 48-60 in-lbs | 5.4-6.8 N-m |
| Windshield screws: frame mounted fairing                               | 8-12 in-lbs  | 0.9-1.4 N-m |

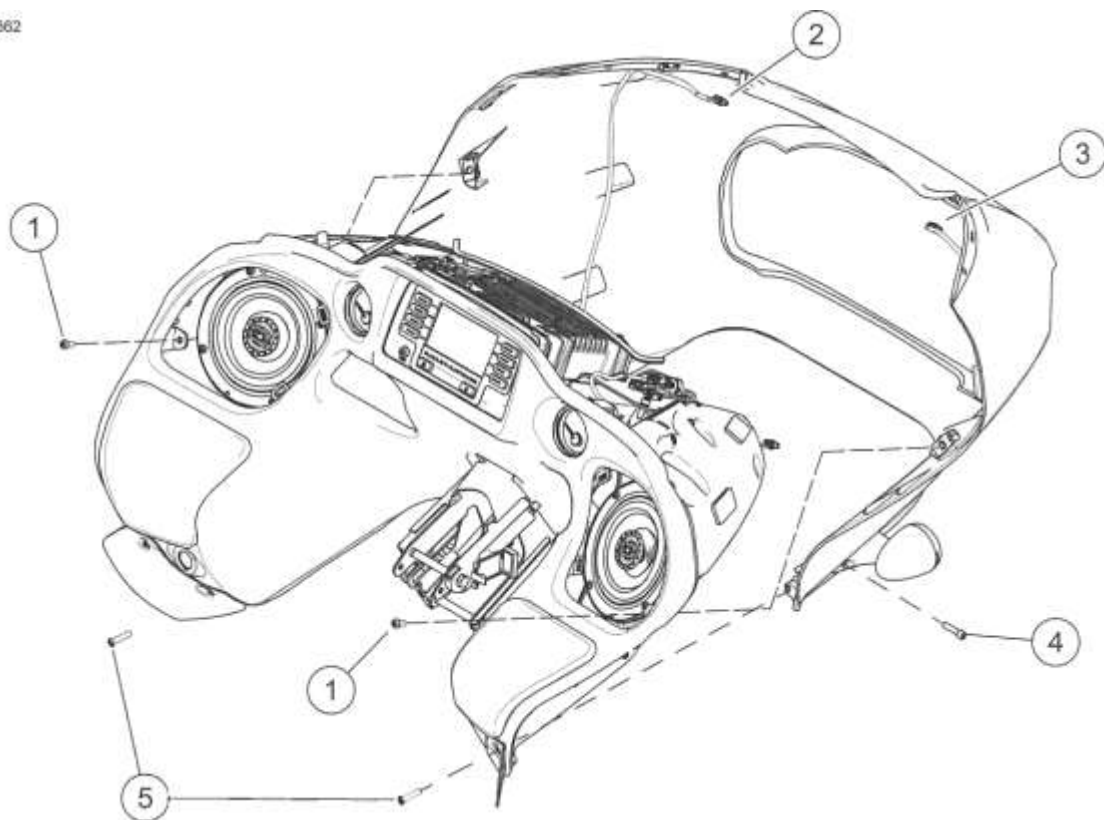
### Remove

1. Remove main fuse. POWER DISCONNECT (Page 8-8)
2. Remove windshield. See Remove and Install: Windshield in this section.
3. Remove air vent. Loosely install two windshield screws to keep fairing from falling in later steps.
4. Remove left and right speaker grilles. See FRONT SPEAKERS (Page 8-70).
5. See Figure 3-113. Separate lamp connectors (2, 3).
6. Remove two upper screws (1).
7. Remove two lamp screws (4).
8. Remove two lower screws (5).
9. Remove windshield screws loosely installed earlier.
10. Pull outer fairing forward to remove.

### Install

1. If damaged, replace the foam strip on upper flange of outer fairing:
  - a. Remove existing foam strip. Remove all residual adhesive.
  - b. Clean mounting area with rubbing alcohol. Allow to dry completely.

- a. Install new foam strip centered within Dimension: 14 in (13 mm)
2. Engage alignment features while sliding outer fairing back into position. Loosely install two windshield screws to prevent fairing from falling.
  3. See Figure 3-113. Start two lamp screws (4).
  4. Start two screws (5).
  5. Start two screws (1).
  6. Install upper screws (1). Tighten.  
Torque: 20-30 in-lbs (2.3-3.4 N-m) *Outer fairing upper screws (near speakers): frame mounted fairing*
  7. Install lower screws (5). Tighten.  
Torque: 8-15 in-lbs (0.9-1.7 N-m) *Outer fairing lower screws (also air deflector): frame mounted fairing*
  8. **NOTE**  
*See Figure 3-114. Do not allow any wiring or connectors to encroach in the darkened area. Interference of the top air duct latch mechanism results.*  
  
Install lamp screws (4). Tighten.  
Torque: 48-60 in-lbs (5.4-6.8 N-m) *Turn signal lamp mounting screw, front: frame mounted fairing*
  9. Mate left (2) and right (3) lamp connectors. Verify that left connector and harness are positioned so they do not interfere with the top air duct latch mechanism.
  10. Install the speaker grilles.
  11. Verify windshield seal is in place on air vent assembly and not damaged.
  12. Verify foam strip is in place on upper flange of outer fairing.
  13. Install the air vent.
  14. Install windshield with four screws. Tighten.  
Torque: 8-12 in-lbs (0.9-1.4 N-m) *Windshield screws: frame mounted fairing*
  15. Install main fuse. See POWER DISCONNECT (Page 8-8).



1. Upper screws, short (2)
2. Left lamp connector
3. Right lamp connector

4. Lamp screws, long (2)
5. Lower screws (2)

Figure 3-113. Outer Fairing Screws

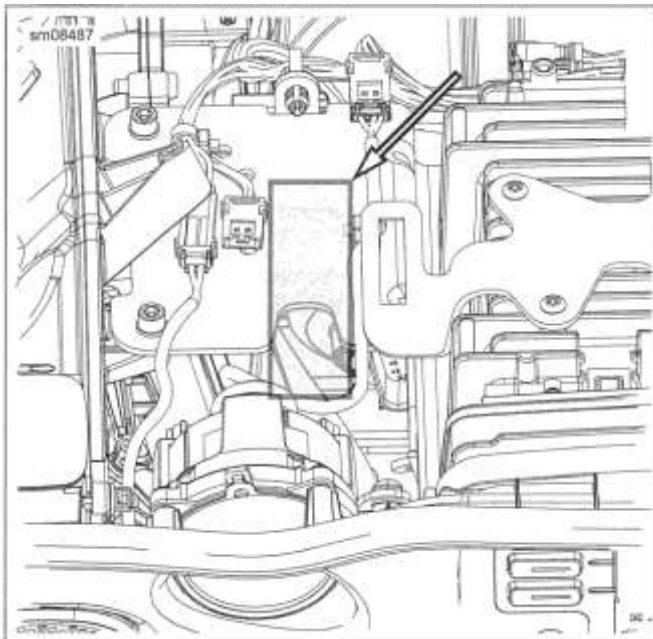


Figure 3-114. Inner Fairing No-Harness Area

**REMOVE AND INSTALL: LOWER VENTS**

| FASTENER                        | TORQUE VALUE |             |
|---------------------------------|--------------|-------------|
| Lower air vent halves           | 9-13 in-lbs  | 1-1.5 N-m   |
| Lower air vent to inner fairing | 8-15 in-lbs  | 0.9-1.7 N-m |

**Remove**

1. Remove outer fairing. See Remove and Install: Outer Fairing Shell in this section.

2. Remove headlamp. See HEADLAMP (Page 8-41).

3. See Figure 3-115. Release main harness connector anchor from hole (1) in radio mount bracket.

4. Remove two screws (3).

5. Remove air vent assembly (2).

6. If necessary: Remove screws holding vent halves together.

**Install**

1. If necessary: Assemble vent halves.

- a. Install new screws securing vent halves together.

- b. Tighten.

Torque: 9-13 in-lbs (1-1.5 N-m) *Lower air vent halves*

2. **NOTE**

See Figure 3-115. Hole in tab must engage pin on inner fairing (see arrow).

Install air duct assembly (2). Secure with two screws (3). Tighten.

Torque: 8-15 in-lbs (0.9-1.7 N-m) *Lower air vent to inner fairing*

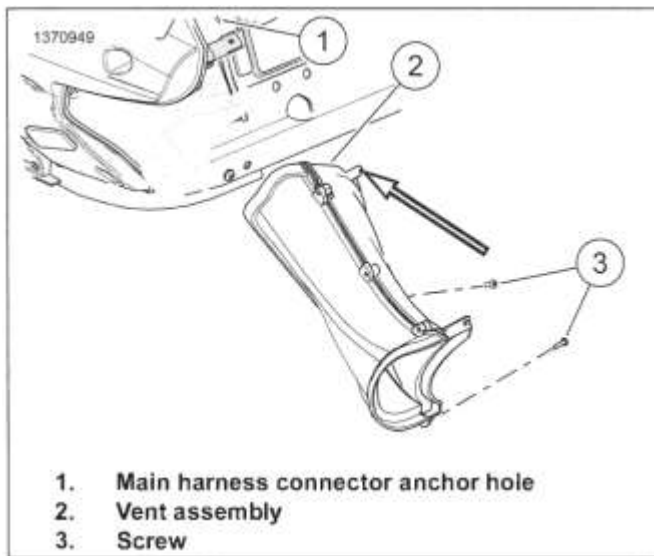


Figure 3-115. Lower Air Vent Assembly (right side shown)

**REMOVE AND INSTALL: INSTRUMENT BEZEL** \_\_\_\_\_  
**REMOVE AND INSTALL: INSTRUMENT NACELLE** \_\_\_\_\_

### Remove

1. See Figure 3-116. Lift rear of ignition switch cover (3). Remove cover.

| FASTENER                | TORQUE VALUE |             |
|-------------------------|--------------|-------------|
| Instrument bezel screws | 10-15 in-lbs | 1.1-1.7 N-m |

2. Rotate ignition switch knob counterclockwise.
3. Remove screws (1) on each side of bezel (2).
4. Lift bezel to access connectors.
5. Disconnect instrument module connector and accessory switch connectors. Remove bezel assembly.

### Install

1. Mate accessory switch connectors.
2. Mate instrument module connector.
3. Lower bezel (2) assembly into place.
4. See Figure 3-116. Install screws (1) on each side of bezel. Tighten  
 Torque: 10-15 **in-lbs** (1.1-1.7 N-m) *Instrument bezel screws*
5. Engage tabs of switch cover (3). Press down on rear to secure.

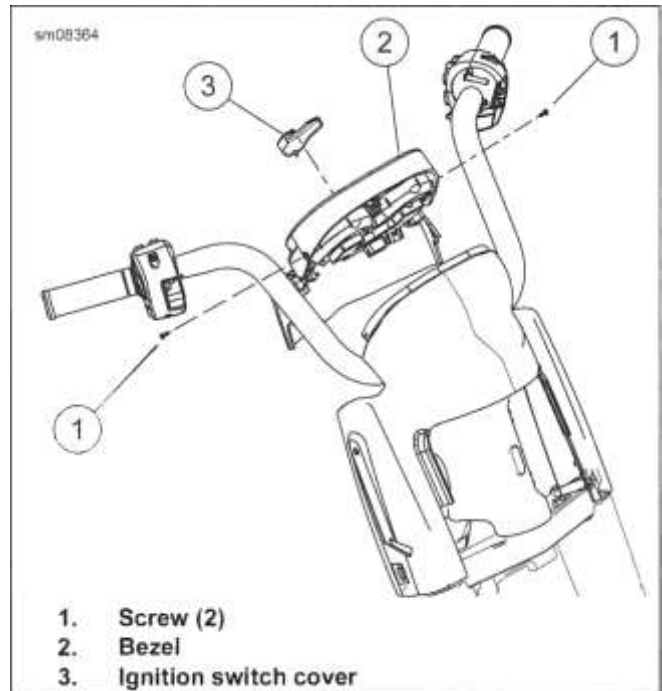


Figure 3-116. Remove Instrument Bezel

### Remove

| FASTENER                                  | TORQUE VALUE |          |
|---|--------------|----------|
| Instrument nacelle to fork bracket screws | 96 in-lbs    | 10.8 N-m |

#### NOTE

*To remove instrument nacelle with inner fairing installed, handlebars must be able to turn.*

1. See Figure 3-117. Remove instrument bezel (1). See Remove and Install: Instrument Bezel in this section.
2. Turn the handlebar until screws (2) can be accessed. Remove screws and flat washers (3). Repeat with opposite side.
3. Remove fairing skirt (4).
4. Pull nacelle halves (5) apart to release two retainers (6).

### Install

1. See Figure 3-117. Verify two retainers (6) are in place.
2. Place nacelle halves into position.
3. While holding nacelle halves in approximate position, install fairing skirt (4).
4. Turn handlebars until screws (2) can be installed.
5. Install screws and flat washers (3). Tighten.  
 Torque: 96 **in-lbs** (10.8 N-m) *Instrument nacelle to fork bracket screws*

6. Repeat with opposite side.

7. Install instrument bezel (1). See Remove and Install: Instrument Bezel in this section.

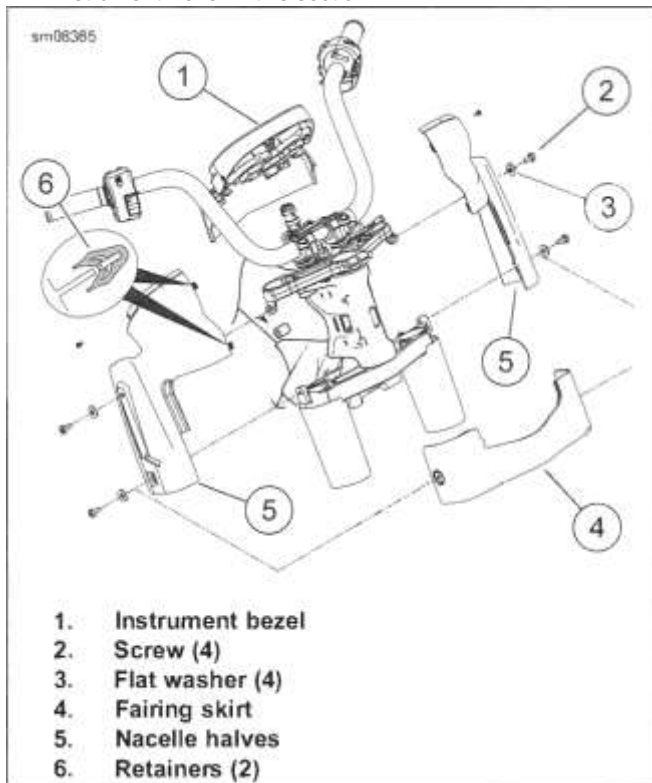


Figure 3-117. Instrument Nacelle

## REMOVE AND INSTALL: INNER FAIRING SHELL

### Remove

| FASTENER   | TORQUE VALUE |             |
|--|--------------|-------------|
| Fairing support bracket-to-engine guard screws                         | 40-50 in-lbs | 4.5-5.7 N-m |
| Fairing support bracket-to-inner fairing screws: Frame-mounted fairing | 48-60 in-lbs | 5.4-6.8 N-m |
| Inner fairing-to-mount screws: Frame-mounted fairing                   | 96 in-lbs    | 10.9 N-m    |

| PART NUMBER | CONSUMABLE  |
|-------------|---|
| 99642-97    | LOCTITE 243 MEDIUM STRENGTH THREADLOCKER AND SEALANT (BLUE) |

- Place protective material on top of front fender to protect paint.
- Remove outer fairing. See Remove and Install: Outer Fairing Shell in this section.
- Remove headlamp. See HEADLAMP (Page 8-41) .
- See Figure 3-118. Separate radio harness connector (1) and antenna cable connector (2) from radio.

5. Release left (3) and right (4) main harness connector anchors. Separate connectors. Release antenna lead retainer located near left main harness retainer.

6. Draw branches of main harness to front of inner fairing through openings in fairing bracket.

7. See Figure 3-119. Remove screws (1) securing left and right fairing support brackets (4) to engine guard (6).

8. Remove screws (7) and washers securing fairing support brackets to inner fairing. Remove support brackets.

9. Remove four screws (3).

### NOTE

*Tabs on inner fairing are engaged in slots (5) on fairing mount.*

10. Lift inner fairing from fairing mount and move to bench area.

### Install

1. Place protective material on top of front fender to protect paint. Rest inner fairing on front fender.

2. See Figure 3-119. Move inner fairing into place while feeding end of harnesses through opening. Engage tabs on bottom of inner fairing with slots (5) in fairing mount.

3. Install fairing support brackets (4) to fairing with screws (7) and washers. Do not tighten.

4. Start four screws (3). Adjust inner fairing until level. Tighten.

Torque: 96 in-lbs (10.9 N-m) *Inner fairing-to-mount screws: Frame-mounted fairing*

5. Secure fairing support brackets:

a. Apply threadlocker to threads of screws (1). Start screws.

LOCTITE 243 MEDIUM STRENGTH

THREADLOCKER AND SEALANT (BLUE) (99642-97)

b. Locate support brackets on engine guard approximately Distance: 6.126 in (155.6 mm) from center of engine guard. Tighten.

6. Tighten fairing support bracket screws.

Torque: 48-60 in-lbs (5.4-6.8 N-m) *Fairing support bracket-to-inner fairing screws: Frame-mounted fairing*

7. See Figure 3-118. Locate radio connector branch of main harness.

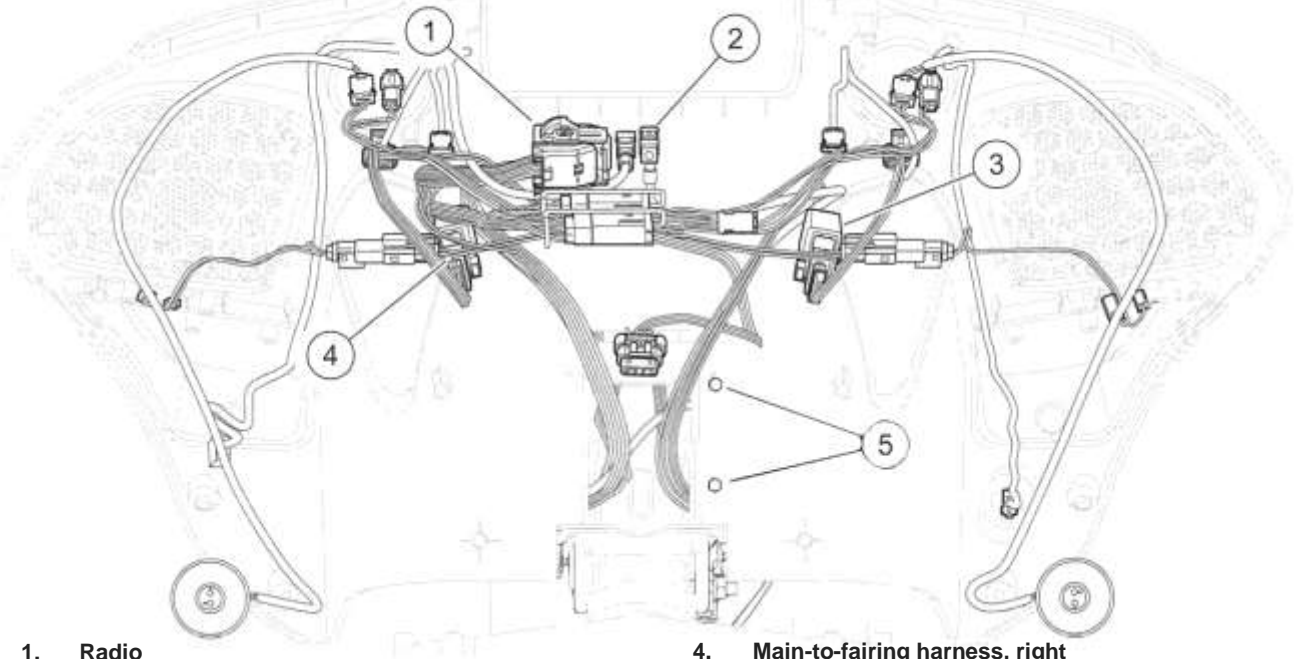
a. Route branch through opening on right side of fairing mount.

b. Mate connectors (1, 4, 6). Secure connector (4) to anchor.

8. Route remaining main harness through left opening of 9. Install headlamp. See HEADLAMP (Page 8-41). fairing mount.
  10. Install outer fairing. See Remove and Install: Outer Fairing a. Shell in this section.
- Mate connectors (2, 3).
- b. Secure connector (3) to anchor.

1535954

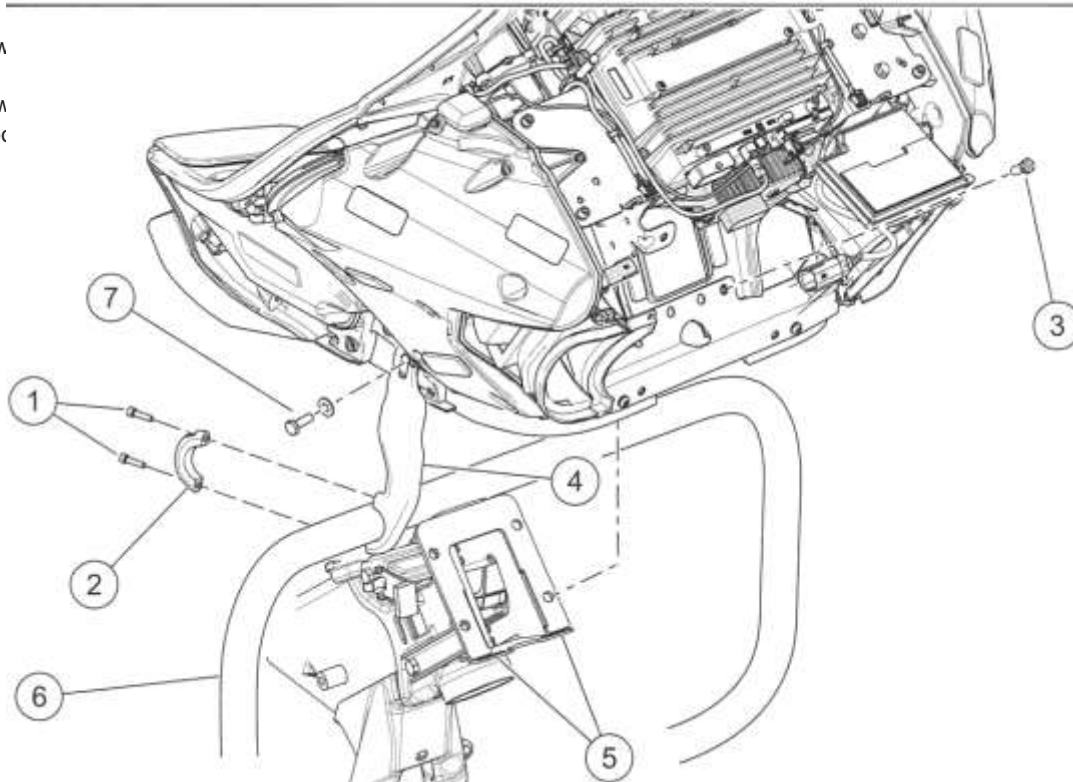
**Figure 3-118. Inner Fairing Harness Connectors**



- |  |  |
|--|--|
| <ol style="list-style-type: none"> <li>1. Radio</li> <li>2. AM/FM radio antenna</li> <li>3. Main-to-fairing harness, left</li> </ol> | <ol style="list-style-type: none"> <li>4. Main-to-fairing harness, right</li> <li>5. Screws (4)</li> </ol> |
|--|--|



1. Screw
2. Cap
3. Screw
4. Suppr



5. Slots in inner fairing mount
6. Engine guard
7. Screw (2)

Figure 3-119. Inner Fairing Mounting

### **DISASSEMBLE AND ASSEMBLE: INNER FAIRING SHELL**

4. See Figure 3-120. Remove radio support bracket upper screws (4).

| FASTENER   | TORQUE VALUE |         |
|--|--------------|---------|
|  | in-lbs       | N-m     |
| Fairing gauge screw  | 8-15         | 0.9-1.7 |
| Fairing speaker enclosure to fairing screws                          | 48-60        | 5.4-6.8 |
| Lower vent to inner fairing: frame-mounted fairing                   | 8-15         | 0.9-1.7 |
| Radio support bracket to inner fairing screws: frame-mounted fairing | 48-60        | 5.4-6.8 |
| Storage compartment screws   | 48-60        | 5.4-6.8 |

#### **Disassemble**

##### *NOTE*

*Never lift fairing assembly by radio face.*

1. Prepare a protective work surface large enough for inner fairing assembly.
2. Remove inner fairing shell. See Remove and Install: Inner Fairing Shell in this section. Lay on protective surface with gauge faces down.
3. *NOTE*  
*Graphic shows only right side screws. Remove same screws from left side.*

Separate gauge jumper connectors (5, 6) from the fairing harness.

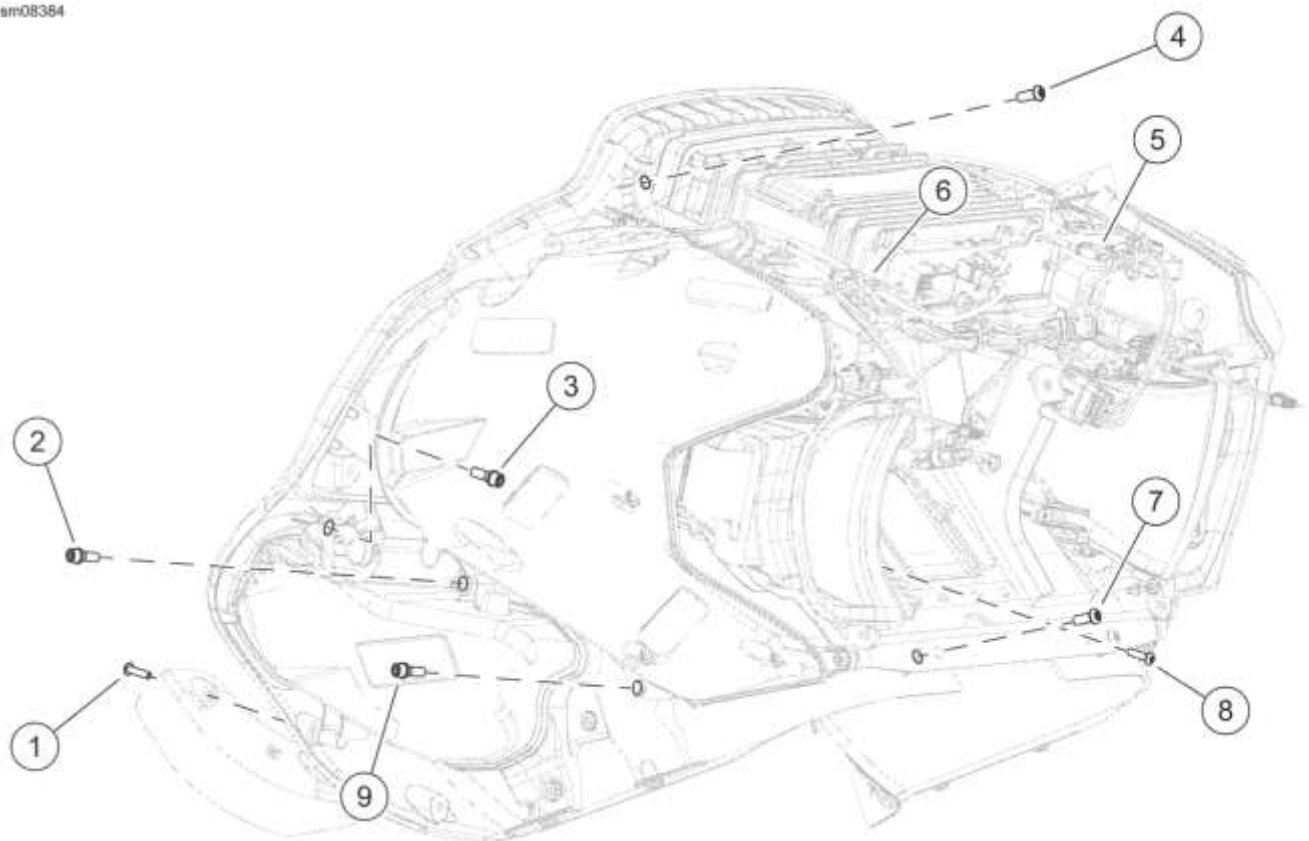
5. Remove speaker enclosure screws (2, 9).
6. Remove radio support bracket lower screws (7).
7. Remove fairing air duct screws (8).
8. *NOTE*  
*Use caution when lifting fairing from support structure assembly to prevent speaker damage.*
- Lift inner fairing support structure assembly off from the fairing shell. Carefully set aside.
9. Remove storage compartment screws (3). Remove storage compartments.
10. Remove fairing power outlet.
11. Remove 2-inch gauges.
12. Remove storage compartment doors and hinges. See Remove and Install: Storage Compartment Doors and Hinges in this section.

#### **Assemble**

1. Place new inner fairing shell face-down on a protective surface.

2. Install storage compartment doors and hinges. See Remove and Install: Storage Compartment Doors and Hinges in this section.
3. Secure 2-inch gauges with screws. Tighten.  
Torque: 8-15 **in-lbs** (0.9-1.7 N-m) *Fairing gauge screw*
4. Install fairing power outlet. Tighten securely.
5. See Figure 3-120. Install storage compartments with screws (3). Tighten.  
Torque: 48-60 **in-lbs** (5.4-6.8 N-m) *Storage compartment screws*
6. Place support structure onto fairing shell. Engage pins on fairing vents into fairing shell.
7. Install radio support bracket upper screws (4). Tighten.  
Torque: 48-60 **in-lbs** (5.4-6.8 N-m) *Radio support bracket to inner fairing screws: frame-mounted fairing*
8. Install speaker enclosure screws (2, 9). Tighten.  
Torque: 48-60 **in-lbs** (5.4-6.8 N-m) *Fairing speaker enclosure to fairing screws*
9. Install radio support bracket lower screws (5). Tighten.  
Torque: 48-60 **in-lbs** (5.4-6.8 N-m) *Radio support bracket to inner fairing screws: frame-mounted fairing*
10. Install fairing air duct screws (8). Tighten.  
Torque: 8-15 **in-lbs** (0.9-1.7 N-m) *Lower vent to inner fairing: frame-mounted fairing*
11. Mate gauge jumper connectors (5, 6).

am08384



- |  |  |
|--|--|
| <ol style="list-style-type: none"> <li>1. Air deflector upper screw</li> <li>2. Speaker enclosure screw (socket head)</li> <li>3. Storage compartment screw (socket head)</li> <li>4. Radio support bracket upper screw (Torx head)</li> <li>5. Fuel gauge jumper connector</li> </ol> | <ol style="list-style-type: none"> <li>6. Voltmeter jumper connector</li> <li>7. Radio support bracket lower screw (Torx head)</li> <li>8. Fairing air duct screw</li> <li>9. Speaker enclosure screw (socket head)</li> </ol> |
|--|--|

Figure 3-120. Inner Fairing Shell Fasteners (right side shown)

**REMOVE AND INSTALL: MOUNTING BRACKET**

**Remove**

| FASTENER   | TORQUE VALUE |                |
|--|--------------|----------------|
| Fairing mount to steering head locknuts: Frame-mounted fairing | 20-30 ft-lbs | 27.1--40.7 N-m |

1. Remove inner fairing assembly.
2. Remove instrument nacelle. See Remove and Install Instrument Nacelle in this section.
3. See Figure 3-121. Remove locknuts (3) and screws (1).

4. Remove fairing mounting bracket.

**Install**

*NOTE*

‘ Pull main harness branches through center of fairing mounting bracket as it is moved into place.

- Route **WSS** cable between the upper and lower legs of inner fairing mounting bracket to the right steering head caddy.

1. See Figure 3-121. Position fairing mounting bracket (5).
2. Position left (4) and right (2) main harness guides. Install screws (1) from right side. Install flange locknuts (3). Tighten.

Torque: 20-30 ft-lbs (27.1-40.7 N-m) *Fairing mount to steering head locknuts: Frame-mounted fairing*

3. Install the instrument nacelle. See Remove and Install: Instrument Nacelle in this section.
4. Install inner fairing assembly.

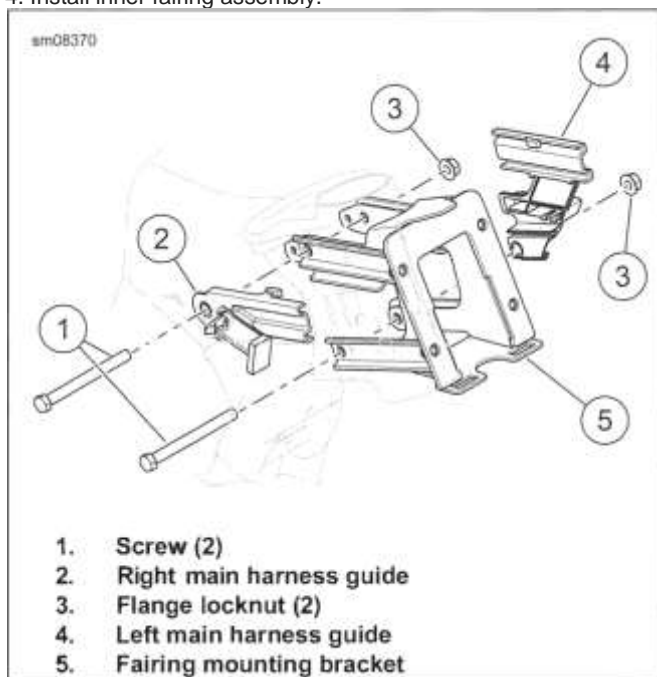


Figure 3-121. Fairing Mounting Bracket

**REMOVE AND INSTALL: RADIO SUPPORT BRACKET**

| FASTENER   | TORQUE VALUE         |               |
|--|----------------------|---------------|
| Inner fairing to mount screws: frame-mounted fairing                 | 96-144 <b>in-lbs</b> | 10.9-16.3 N-m |
| Radio support bracket to inner fairing screws: frame-mounted fairing | 48-60 <b>in-lbs</b>  | 5.4-6.8 N-m   |

**Prepare**

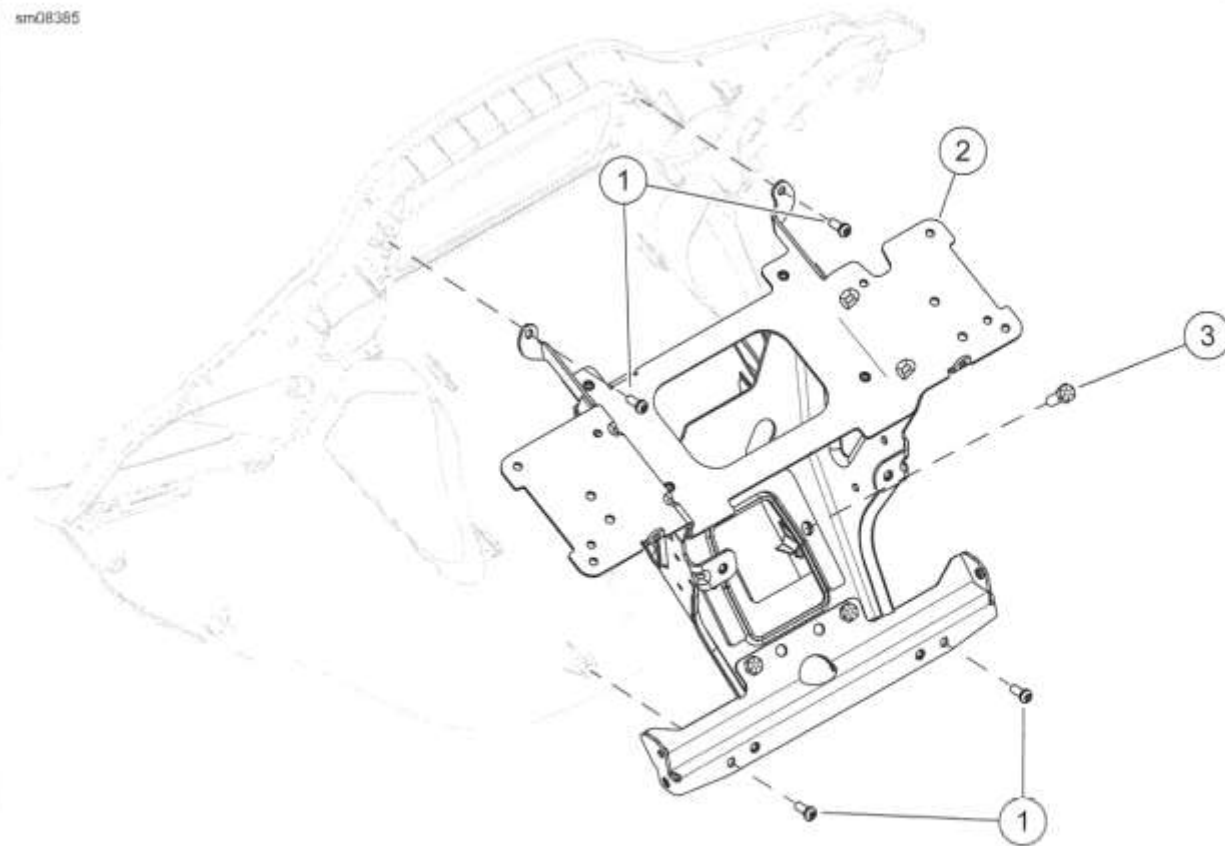
1. Place protective material on front fender.
2. Remove outer fairing. See Remove and Install: Outer Fairing Shell in this section.
3. Remove upper vent. See Remove and Install: Upper Vent in this section.
4. Remove headlamp. See HEADLAMP (Page 8-41).
5. Remove radio. See RADIO (Page 8-67).
6. Remove speaker enclosures. See FRONT SPEAKERS (Page 8-70).
7. Remove lower vents. See Remove and Install: Lower Vents in this section.
8. Release connector retainers and wire retainers from top of radio support bracket. Move harnesses out of the way.
9. Release left and right main harness connector anchors. Separate connectors.
10. Draw branches of main harness to front of inner fairing through openings in fairing bracket.

**Remove**

1. See Figure 3-122. Remove four screws (1).
2. Remove four screws (3).
3. Lift bracket (2) following angle of fairing mount. Remove radio support bracket while feeding harnesses through center opening.

**Install**

1. Set the radio support bracket in place on the inner fairing. Verify the two tabs on the bottom of the bracket engage the slots in the fairing mount.
2. See Figure 3-122. Install four screws (3) finger-tight.
3. Install four screws (1). Tighten.  
Torque: 48-60 **in-lbs** (5.4-6.8 N-m) *Radio support bracket to inner fairing screws: frame-mounted fairing*
4. Tighten screws (3).  
Torque: 96-144 **in-lbs** (10.9-16.3 N-m) *Inner fairing to mount screws: frame-mounted fairing*



1. Radio support bracket upper screws (4)  
2. Radio support bracket

3. Fairing mounting screws (4)

Figure 3-122. Radio Support Bracket

### Complete

1. Install lower vents. See Remove and Install: Lower Vents in this section.
2. Install speaker enclosures. See FRONT SPEAKERS (Page 8-70).
3. Install radio. See RADIO (Page 8-67).
4. Secure connector anchors and wire anchors to top of radio support bracket. See FAIRING WIRE HARNESS (Page 8-116).
5. See Figure 3-118. Locate radio connector branch of main harness.
  - a. Route branch through opening on right side of fairing mount.
  - b. Mate connectors (1, 4). Secure connector (4) to anchor.
6. Route remaining main harness through left opening of fairing mount.
  - a. Mate connectors (2, 3).
  - b. Secure connector (3) to anchor.

7. Install headlamp. See HEADLAMP (Page 8-41).

8. Install upper vent. See Remove and Install: Upper Vent in this section.
9. Install outer fairing. See Remove and Install: Outer Fairing Shell in this section.

### REMOVE AND INSTALL: STORAGE COMPARTMENT DOORS AND HINGES

| FASTENER                              | TORQUE VALUE |             |
|---------------------------------------|--------------|-------------|
| Storage compartment door hinge screws | 8-15 in-lbs  | 0.9-1.7 N-m |
| Storage compartment door screws       | 8-15 in-lbs  | 0.9-1.7 N-m |

| PART NUMBER | CONSUMABLE  |
|-------------|---|
| 99642-97    | LOCTITE 243 MEDIUM STRENGTH THREADLOCKER AND SEALANT (BLUE) |

### Replace Storage Compartment Door

1. See Figure 3-123. Hold door (1) open. Remove four screws (4) .

## Replace Storage Compartment Door

- See Figure 3-123. Apply threadlocker to threads of screws (4).  
Consumable: LOCTITE 243 MEDIUM STRENGTH THREADLOCKER AND SEALANT (BLUE) (99642-97)
- Install new door with four screws (4).
- Align door. Tighten.  
Torque: 8-15 in-lbs (0.9-1.7 N-m) *Storage compartment door screws*

## Remove Storage Compartment Door/Hinge

- Remove storage compartment. See Remove and Install: Storage Compartments in this section.
- See Figure 3-123. Remove screws (4) and door (1).
- Remove screws (3). Remove hinge assembly (2).

### NOTE

Hinge cannot be repaired. Replace assembly upon failure.

## Install Storage Compartment Door/Hinge

- NOTE**  
See Figure 3-123. If removed, install new storage compartment door bumpers (5) in door.

Install hinge with four screws (3). Tighten.

Torque: 8-15 in-lbs (0.9-1.7 N-m) *Storage compartment door hinge screws*

- Apply threadlocker to threads of screws (4).  
Consumable: LOCTITE 243 MEDIUM STRENGTH THREADLOCKER AND SEALANT (BLUE) (99642-97)
- Place storage compartment door into position. Secure with four screws (4). Tighten.  
Torque: 8-15 in-lbs (0.9-1.7 N-m) *Storage compartment door screws*
- Install storage compartment. See Remove and Install: Storage Compartments in this section.

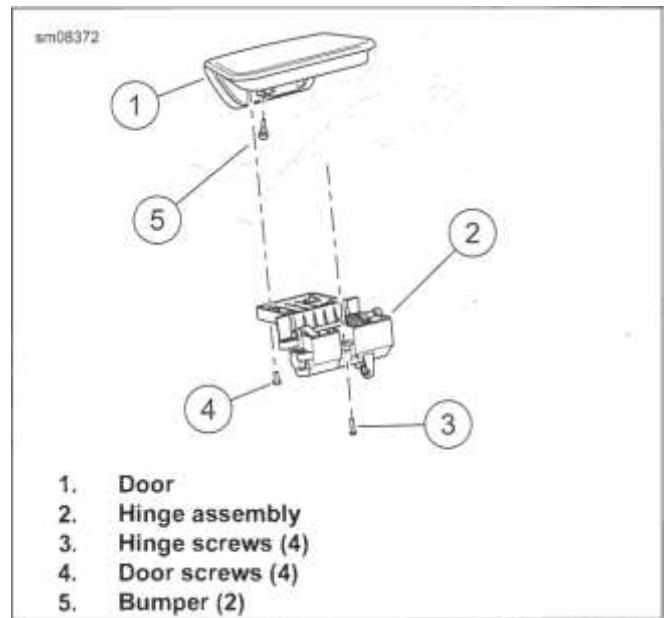


Figure 3-123. Glove Box Door and Hinge

## REMOVE AND INSTALL: STORAGE COMPARTMENTS

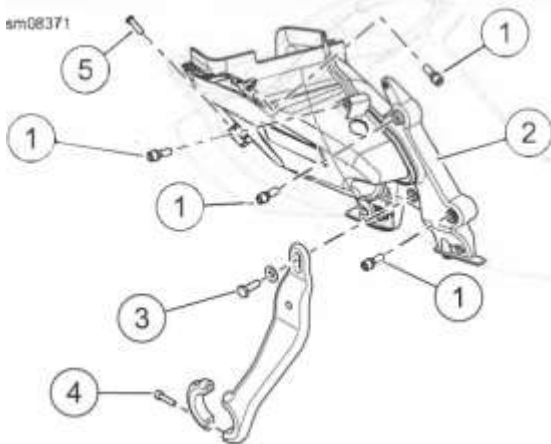
| FASTENER   | TORQUE VALUE |             |
|--|--------------|-------------|
| Fairing air deflector screws:<br>Frame-mounted fairing                 | 8-15 in-lbs  | 0.9-1.7 N-m |
| Fairing support bracket-to-engine guard screws                         | 40-50 in-lbs | 4.5-5.7 N-m |
| Fairing support bracket-to-inner fairing screws: Frame-mounted fairing | 48-60 in-lbs | 5.4-6.8 N-m |
| Storage compartment screws   | 48-60 in-lbs | 5.4-6.8 N-m |

### Remove

- Remove outer fairing. See Remove and Install: Outer Fairing Shell in this section.
- Release harness:
  - Left side: Release accessory power connector harness from features on storage compartment.
  - Right side: Release media cable retainer from upper speaker enclosure. Disconnect from radio.
- See Figure 3-124. Remove fairing support bracket:
  - Loosen two screws (4) securing fairing support bracket to engine guard.
  - Remove screw (3) and washer securing fairing support bracket to inner fairing.
- Remove air deflector upper screw (5).
- Remove four screws (1). Remove media storage compartment.

## Install

1. See Figure 3-124. Route harness into position as storage compartment is moved into place.
2. Position storage compartment. Start four screws (1).
3. Install air deflector with air deflector upper screw (5). Tighten.  
  
Torque: 8-15 **in-lbs** (0.9-1.7 N-m) *Fairing air deflector screws: Frame-mounted fairing*
4. Tighten screws (1).  
  
Torque: 48-60 **in-lbs** (5.4-6.8 N-m) *Storage compartment screws*
5. Secure and connect harness.
6. Install fairing support bracket:
  - a. Secure fairing support bracket to inner fairing with screw (3) and washer. Tighten.  
  
Torque: 48-60 **in-lbs** (5.4-6.8 N-m) *Fairing support bracket-to-inner fairing screws: Frame-mounted fairing*
  - b. Tighten fairing support bracket screws (4).  
  
Torque: 40-50 **in-lbs** (4.5-5.7 N-m) *Fairing support bracket-to-engine guard screws*
7. Install outer fairing. See Remove and Install: Outer Fairing Shell in this section.



1. Socket head screws (4)
2. Glove box
3. Screw, support bracket
4. Screw, support bracket clamp (2)
5. Air deflector upper screw

Figure 3-124. Media Storage Compartment

## REMOVE AND INSTALL: MEDIA CABLE

### Remove

1. See Figure 3-125. Disconnect connector (1) from radio.

2. Remove and discard anchored cable strap (2) from upper speaker enclosure.
3. Remove right storage compartment. See Remove and Install: Storage Compartments in this section.
4. Remove and discard anchored cable strap (2) from media storage compartment.
5. Compress grommet (3) and push into storage compartment.

### Install

1. See Figure 3-125. Route media cable from inside through right storage compartment.
2. Adjust length of cable and install grommet (3).
3. Install **new** anchored cable strap (2) to media storage compartment.
4. Install storage compartment. See Remove and Install: Storage Compartments in this section.
5. Route media cable to radio.
6. Install **new** anchored cable strap (2) to upper speaker enclosure.
7. Connect connector (1) to radio.

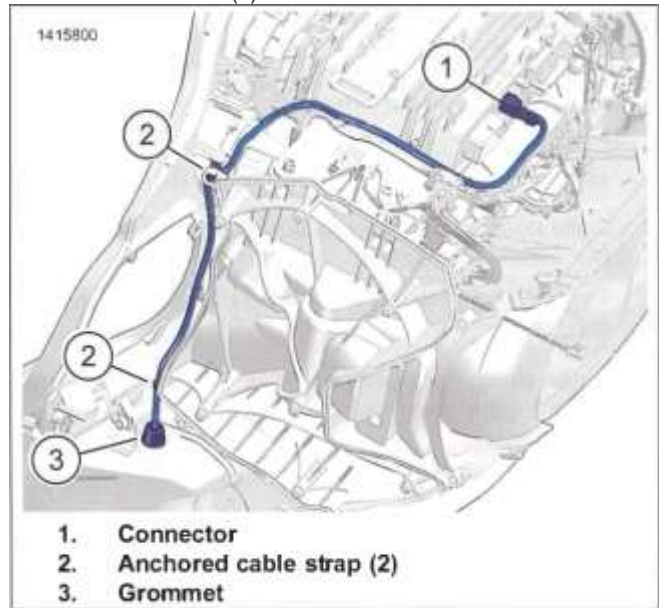


Figure 3-125. Fix Fairing USB Cable

| FASTENER                        | TORQUE VALUE         |             |
|---------------------------------|----------------------|-------------|
| Lower fairing cap flange nut    | 30-35 <b>in-lbs</b>  | 3.4-3.9 N-m |
| Lower fairing, lower clamp      | 90-100 <b>in-lbs</b> | 10.2-11.3Nm |
| Lower fairing, upper clamp nuts | 30-35 <b>in-lbs</b>  | 3.4-3.9 N-m |

**Remove**

1. Open glove box door.
2. See Figure 3-126. Remove fairing cap.
  - a. Remove flange nut (1) securing fairing cap (3).
  - b. Remove fairing cap and flat washer (10).
3. Remove lower fairing clamp screw (9) and nut (6). Discard rubber washer (8).
4. Remove flange nuts (4) and upper clamp (2).
5. Remove lower fairing assembly.

**Install**

1. Place fairing lower into position.
2. See Figure 3-126. Loosely install upper clamp (2) with two flange nuts (4).
3. Loosely install **new** rubber washer (8), clamp (7), screw (9) and nut (6).
4. See Figure 3-127. Align upper clamp to dimension (1).
5. See Figure 3-126. Tighten flange nuts (4).  
 Torque: 30-35 **in-lbs** (3.4-3.9 N m) *Lower fairing, upper clamp nuts*

**NOTE**

See Figure 3-127. Clearance from vent openings to shift lever (2) and brake pedal (3) should approximately match the distance shown.

6. See Figure 3-126. Verify that fairing lower is aligned. Tighten lower screw (9).  
 Torque: 90-100 **in-lbs** (10.2-11.3 N-m) *Lower fairing, lower clamp*

7. Place flat washer (10) on fairing cap stud.
8. Install fairing cap (3) with flange nut (1). Tighten.  
 Torque: 30-35 **in-lbs** (3.4-3.9 N-m) *Lower fairing cap flange nut*
9. Close glove box door.



Figure 3-126. Lower Fairing: Air Cooled

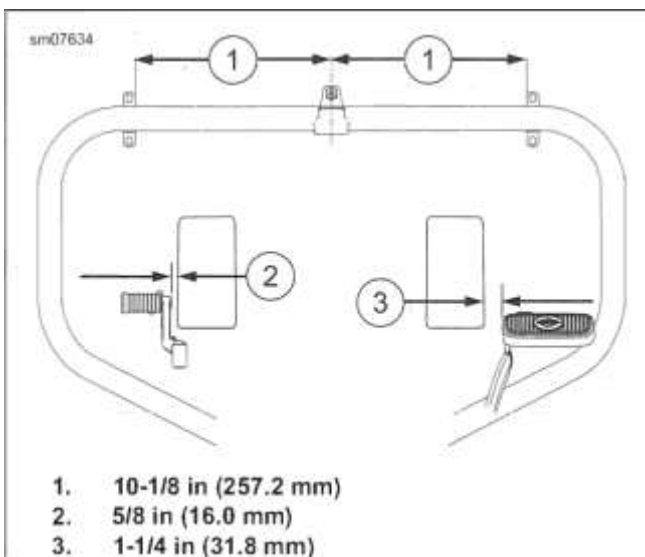


Figure 3-127. Lower Fairing Mounting Dimensions

**REMOVE AND INSTALL: TWIN-COOLED**

| FASTENER                        | TORQUE VALUE         |               |
|---------------------------------|----------------------|---------------|
| Lower fairing cap flange nut    | 30-35 <b>in-lbs</b>  | 3.4-3.9 N-m   |
| Lower fairing, lower clamp      | 90-100 <b>in-lbs</b> | 10.2-11.3 N-m |
| Lower fairing, upper clamp nuts | 30-35 <b>in-lbs</b>  | 3.4-3.9 N-m   |

## Remove

1. Remove main fuse. See POWER DISCONNECT (Page 8-8).
2. Remove fairing lower access panel. Pry at center top and near each lower corner to release retainers.

### 3. NOTE

*Fairing lower shell may be removed without opening cooling system.*

#### Fairing lower shell only:

- a. Remove fan. See COOLING FAN (Page 8-91).
  - b. Allow radiator to hang by hoses.
4. Drain coolant system. See INSPECT RADIATOR AND COOLANT (Page 2-34).
  5. See Figure 3-128. Disconnect upper hose (2) from the upper cross tube. Disconnect lower hose (6) from pump assembly.
  6. Disconnect fan power connector (7) located near pump.
  7. Remove flange nut (1) securing fairing cap (4). Remove fairing cap and flat washer (12).
  8. Remove fairing lower clamp screw (11) and nut (8). Discard rubber washer (10).
  9. Remove flange nuts (5) securing upper clamp (3).
  10. Remove fairing lower assembly.

## Install

1. Place fairing lower into position.
2. See Figure 3-128. Install upper clamp (3) and two flange nuts (5). Leave fasteners loose.
3. Install **new** rubber washer (10), clamp (9), screw (11) and nut (8). Leave fasteners loose.
4. See Figure 3-129. Align upper clamp to dimension (1).
5. See Figure 3-128. Tighten flange nuts (5) to:  
Torque: 30-35 **in-lbs** (3.4-3.9 N-m) *Lower fairing, upper clamp nuts*

### NOTE

*See Figure 3-129. Verify shift lever and brake pedal do not contact fairing lower vent. Clearance from the vent openings to the shift lever (2) and brake pedal (3) should approximately match the distance shown.*

6. See Figure 3-128. Verify that fairing lower is aligned. Tighten lower screw (11) to:  
Torque: 90-100 **in-lbs** (10.2-11.3 N-m) *Lower fairing, lower clamp*

7. Place flat washer (12) on stud of fairing cap. Install fairing cap (4) with flange nut (1). Tighten to:  
Torque: 30-35 **in-lbs** (3.4-3.9 N-m) *Lower fairing cap flange nut*
8. Verify shift lever and brake pedal do not contact fairing lower vent.
9. Connect fan power connector (7) located near pump.
10. Connect upper (2) and lower (6) radiator hoses.
11. Install main fuse.
12. Fill coolant system. See INSPECT RADIATOR AND COOLANT (Page 2-34).
13. Install fairing lower access panel.
14. Install coolant pump cover.

1. Flange nut, fairing cap
2. Upper radiator hose

351058



3. Upper clamp
4. Lower fairing cap
5. Flange nuts, upper clamp (2)
6. Lower radiator hose
7. Connector
8. Nut, lower clamp
9. Lower clamp
10. Rubber washer
11. Screw, lower clamp
12. Flat washer

**Figure 3-128. Lower Fairing: Twin-Cooled**



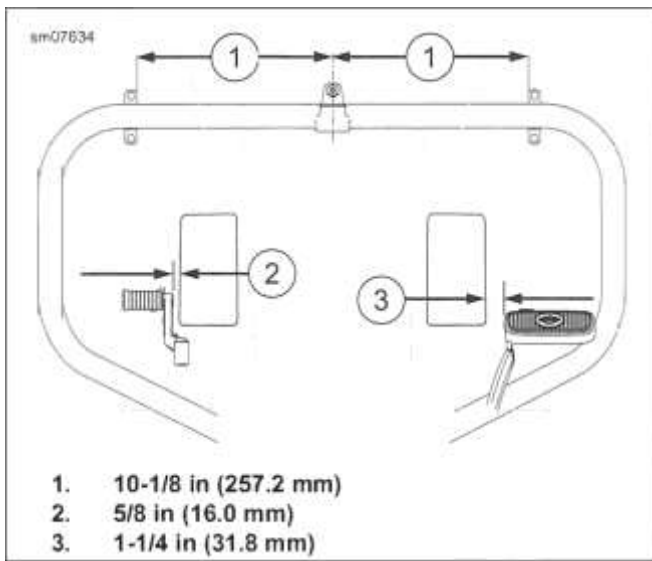


Figure 3-129. Lower Fairing Mounting Dimensions

### DISASSEMBLE AND ASSEMBLE: AIR-COOLED

| FASTENER                            | TORQUE VALUE |             |
|-------------------------------------|--------------|-------------|
| Fairing lower inner panel screws    | 65-75 in-lbs | 7.3-8.5 N-m |
| Lower fairing glove box screws      | 12-17 in-lbs | 1.4-1.9 N-m |
| Lower fairing glove box tray screws | 12-18 in-lbs | 1.4-2 N-m   |
| Lower fairing vent knob screw       | 12-18 in-lbs | 1.4-2 N-m   |

#### Disassembly

1. Remove grille panel.
  - a. See Figure 3-126. Carefully pry on curved edge of grille plate (5) to release retainers.
  - b. Remove from fascia.
2. See Figure 3-130. Remove two screws (9) securing inner panel (8).
3. Remove three screws securing glove box frame to fairing lower.
4. Pull glove box frame away and pull vent link (4) down to disconnect from vent door lever.
5. See Figure 3-131. Remove three screws (7) to release glove box tray (8).
6. Remove screw (5) to disassemble knob from link.
7. Squeeze tabs to release latch (2).
8. Remove glove box door.
  - a. Disengage spring (12).
  - b. Remove push nuts (14) from pins (11).
  - c. Remove pins. Remove door.

- d. If necessary, remove damper (13).

9. Remove vent door.
  - a. See Figure 3-130. Rotate lever (5) to position shown.
  - b. Lift lever assembly to remove. Remove door (6).
  - c. Push up on lower pivot pin (7) to remove.

10. **NOTE**  
*The fascia can be removed and installed without removing the lower fairing.*

**NOTE**  
*Do not damage the painted area next to the fascia.*

Remove fascia.

- a. See Figure 3-132. The fascia is retained by double-faced adhesive at locations shown.
- b. Starting around the opening, push the fascia outward to loosen the medium (2) and small (1) tape strips.
- c. Using a Length: <sup>3</sup>A in (19 mm) flexible putty knife, push between the fascia and fairing housing to cut the large tape strips (3). A small amount of dish soap or liquid lubricant on the knife blade eases this process.
- d. Separate fascia from fairing lower housing. Remove all remaining adhesive. Wash thoroughly with isopropyl alcohol. Allow to dry completely.

#### Assembly

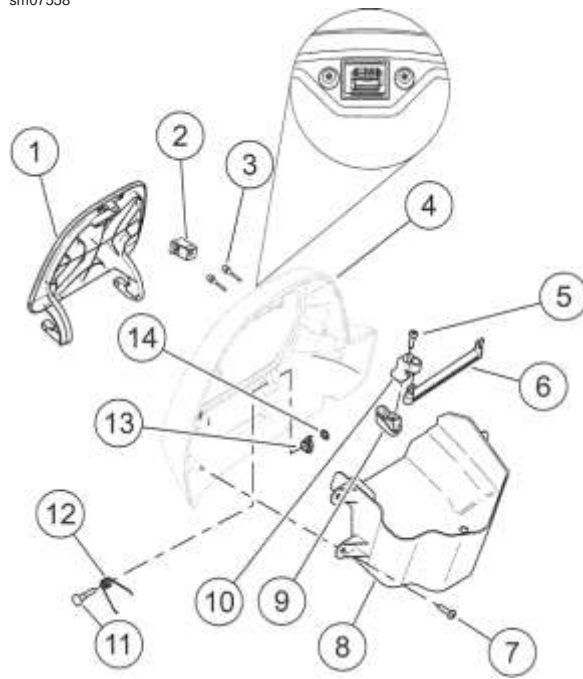
1. Install fascia.
  - a. See Figure 3-132. Verify tape locations are clean and dry.

**NOTE**  
*Replacement fascia has adhesive strips installed.*

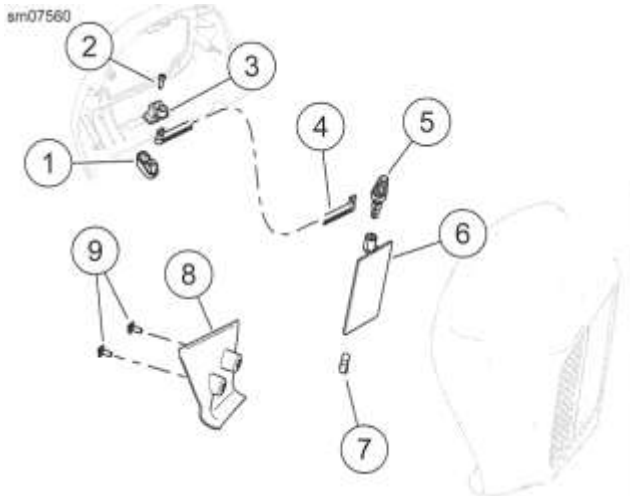
- b. If installing original fascia, place **new** adhesive strips on fascia in locations shown.
- c. Align fascia and press into place. Apply pressure at each tape location for 10-15 seconds.
2. Install vent door.
  - a. See Figure 3-130. Install lower pivot pin (7) in fairing housing.
  - b. Rotate lever (5) to position shown.
  - c. Place door on lower pivot pin (7). Hold door (6) at approximate 45 degree angle as shown and install lever (5). Rotate door to verify operation.
3. Install glove box door.
  - a. See Figure 3-131. If removed, install damper (13).

- b. Fit spring (12) on pin opposite damper. Install pins to secure door.
  - c. Install **new** push nuts (14).
  - d. Engage spring.
4. Install latch oriented as shown in inset. Note that latch and latch opening are not symmetrical.
  5. Apply a film of ELECTRICAL CONTACT LUBRICANT to the upper area along the slot where the slider runs.
  6. Install screw (5) to secure knob to slider. Tighten.  
Torque: 12-18 **in-lbs** (1.4-2 N-m) *Lower fairing vent knob screw*
  7. Install three screws (7) to secure glove box tray to glove box. Tighten.  
Torque: 12-18 **in-lbs** (1.4-2 N-m) *Lower fairing glove box tray screws*
  8. Engage linkage to vent door arm.
  9. See Figure 3-130. Install inner panel (8) with screws (9). Tighten.  
Torque: 65-75 **in-lbs** (7.3-8.5 N-m) *Fairing lower inner panel screws*
  10. Secure glove box assembly to fairing lower with three screws. Tighten.  
Torque: 12-17 **in-lbs** (1.4-1.9 N-m) *Lower fairing glove box screws*
  11. Install grille plate.

sm07558



1. Door
2. Latch
3. Bumpers
4. Frame, glove box
5. Screw, link to knob
6. Link
7. Screw, glove box
8. Glove box tray
9. Knob, vent
10. Slider
11. Hinge pin
12. Spring
13. Damper
14. Push nut



1. Knob
2. Screw
3. Slider
4. Link
5. Lever
6. Vent door
7. Lower pivot pin
8. Inner panel
9. Screws, inner panel

Figure 3-130. Lower Fairing Components

Figure 3-131. Glove Box

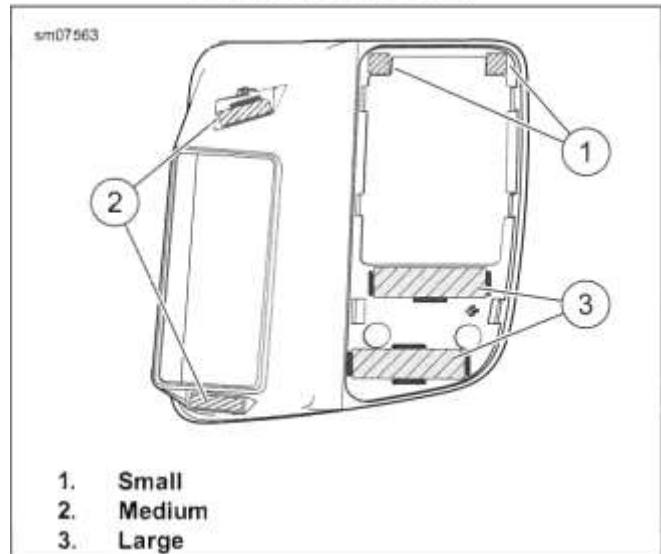


Figure 3-132. Fascia Adhesive Locations

**DISASSEMBLE AND ASSEMBLE: TWIN-COOLED**

1. For removal and installation of cooling system components, see Cooling System (Page 7-1).

2. For fairing disassembly and assembly, see DISASSEMBLE AND ASSEMBLE: AIR-COOLED in this section.

## PREPARE \_\_\_\_\_

1. Remove lower fairings, if present. See FAIRING LOWERS (Page 3-113).
2. Remove lower fairing clamps from engine guard.

## REMOVE \_\_\_\_\_

1. See Figure 3-133. Remove two screws (1) to release ends of engine guard from frame weldments.
2. Remove screws (2) and flat washer (3) and remove engine guard.

## INSTALL \_\_\_\_\_

| FASTENER                           | TORQUE VALUE  |               |
|------------------------------------|---------------|---------------|
| Coolant down tube upper screws (2) | 90-110 in-lbs | 10.2-12.4 N-m |
| Engine guard lower screws          | 15-20 ft-lbs  | 20.3-27.1 N-m |
| Engine guard upper screws          | 22-28 ft-lbs  | 29.8-37.9 N-m |

1. See Figure 3-133. Insert tab at top of engine guard into slot at base of steering head. Start screw (2) with flat washer (3).
2. Secure lower ends of engine guard to frame weldments with screws (1). Tighten.  
Torque: 15-20 ft-lbs (20.3-27.1 N-m) *Engine guard lower screws*
3. Tighten upper screw (2).

**a. Except FLHRXS, FLHXS, FLTRXS:**

Torque: 22-28 ft-lbs (29.8-37.9 N-m) *Engine guard upper screws*

**b. On FLHRXS, FLHXS, FLTRXS:**

Torque: 90-110 in-lbs (10.2-12.4 N-m) *Coolant down tube upper screws (2)*

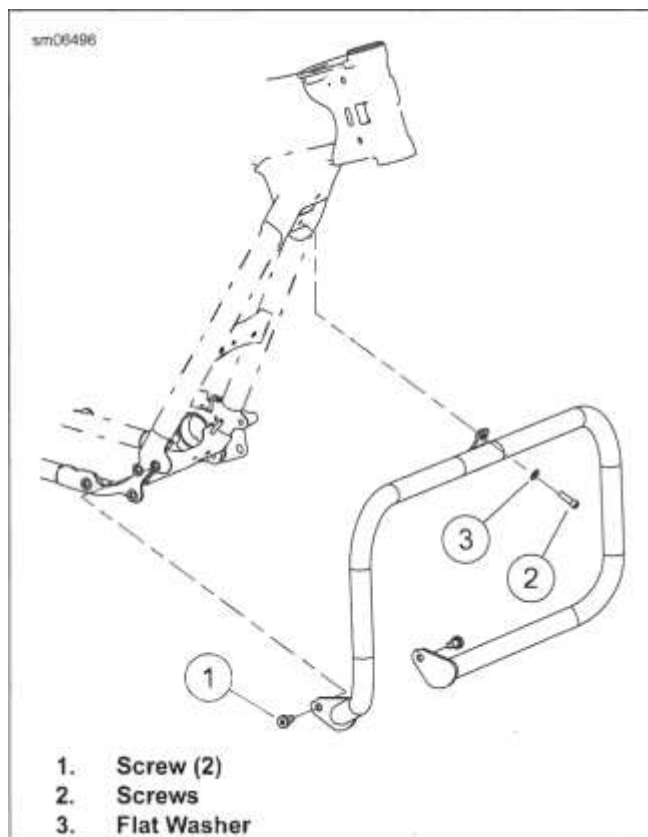


Figure 3-133. Engine Guard

### COMPLETE

1. Install lower fairing clamps on each side of engine guard. Install lower fairings, if present. See FAIRING LOWERS (Page 3-113).

**REMOVE AND INSTALL: FORK MOUNTED FAIRING**

| FASTENER   | TORQUE VALUE |             |
|--|--------------|-------------|
| Fairing air deflector screws<br>fork-mounted fairing | 15-25 in-lbs | 1.7-2.8 N-m |

**Remove**

1. See Figure 3-134. Remove three screws to release air deflector at side of inner fairing.
2. Repeat previous step on opposite side.

**Install**

1. See Figure 3-134. Install three screws to fasten air deflector at side of inner fairing. Alternately tighten screws.  
Torque: 15-25 in-lbs (1.7-2.8 N-m) *Fairing air deflector screws fork-mounted fairing*
2. Repeat previous step on opposite side.

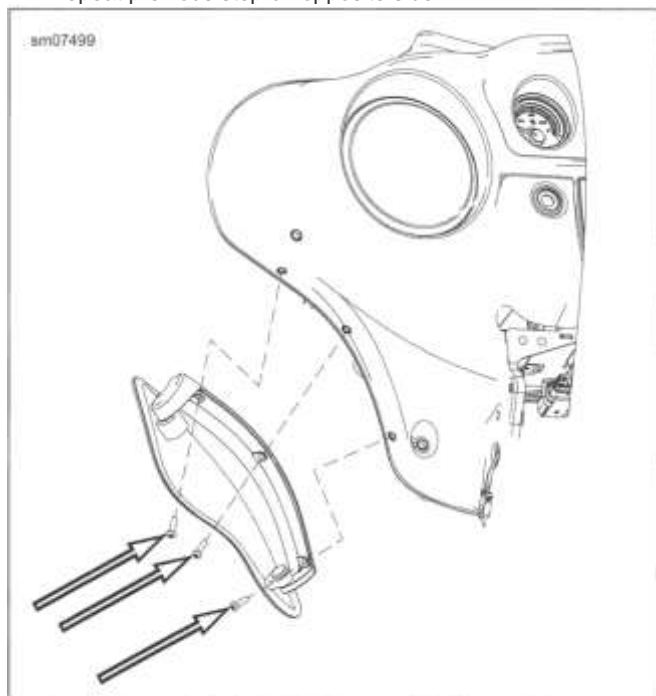


Figure 3-134. Air Deflector (Adjustable)

**REMOVE AND INSTALL: FRAME MOUNTED FAIRING**

| FASTENER  | TORQUE VALUE |             |
|---|--------------|-------------|
| Fairing air deflector screws<br>frame-mounted fairing | 8-15 in-lbs  | 0.9-1.7 N-m |

**Remove**

1. See Figure 3-135. Remove two screws.
2. Repeat previous step on opposite side.

**Install**

1. See Figure 3-135. Install two screws to fasten air deflector at side of inner fairing. Alternately tighten screws.  
Torque: 8-15 in-lbs (0.9-1.7 N-m) *Fairing air deflector screws frame-mounted fairing*
2. Repeat previous step on opposite side.

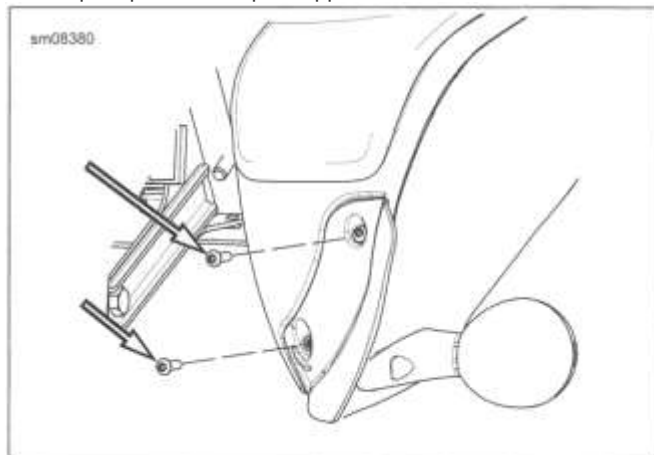


Figure 3-135. Air Deflector (right side shown)

**REMOVE AND INSTALL: MID FRAME DEFLECTORS**

| FASTENER                  | TORQUE VALUE |           |
|---------------------------|--------------|-----------|
| Mid-Frame deflector screw | 25-35 in-lbs | 2.8-4 N-m |

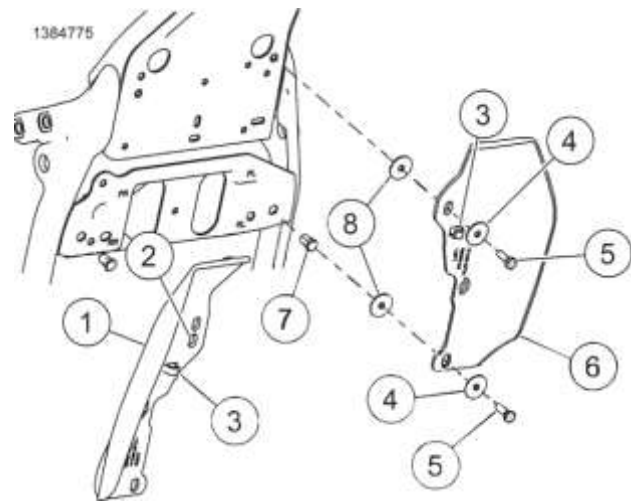
**Remove**

1. See Figure 3-136. Release rear spark plug wire from retainer (3).
2. **NOTE**  
*Models using smoke tinted air deflectors have washers between deflector and frame.*  
Remove deflector.
  - a. Loosen screws (5).
  - b. Remove screws, washers (4), air deflector (1 or 6) and if equipped, washers (8) from frame.

**Install**

1. See Figure 3-136. Install deflectors.
  - a. If removed: Install upper-right screw (5) through washer (4), hole (2) and washer (8) if equipped.
  - b. Install washers (8) if equipped, air deflector (1 or 6), washers (4) and screws (5).
  - c. Tighten screws.  
Torque: 25-35 in-lbs (2.8-4 N-m) *Mid-Frame deflector screw*

2. Secure rear spark plug wire in retainer (3).



1. Right air deflector
  2. Upper-right mount hole
  3. Spark plug cable retainer
  4. Washer (4)
  5. Screw (4)
  6. Left air deflector
  7. Clinch nut (2)
  8. Washer (4) (With smoke tinted air deflectors)
- Figure 3-136. Mid-Frame Air Deflector

**REMOVE**

1. Raise both wireform latch springs.
2. Move top of windshield forward to disengage from upper grommets.
3. Raise windshield to disengage from lower grommets.

**INSTALL**

1. Firmly seat bottom of windshield bracket to engage lower grommets.
2. Push top of windshield rearward to engage top grommets.
3. Push down on the wireform latch springs so that they overhang the rubber grommets.

**DISASSEMBLE**

| PART NUMBER | TOOL NAME         |
|-------------|-------------------|
| HD-25070    | ROBINAIR HEAT GUN |

| PART NUMBER | CONSUMABLE                          |
|-------------|-------------------------------------|
|             | 3M GENERAL PURPOSE ADHESIVE REMOVER |

1. Remove windshield. See WINDSHIELD (Page 3-121).
2. Place windshield front side up on clean padded surface.
3. See Figure 3-137. Remove acorn nuts (3) and discard screws (1,2) from each vertical brace to release mounting bracket.
4. Remove three remaining screws from horizontal brace.
5. Carefully pry braces (4, 6, 7) from windshield. Discard windshield.
6. Remove adhesive strip from braces:
  - a. Liberally apply adhesive remover. Allow to soak.

3M GENERAL PURPOSE ADHESIVE REMOVER ()

**A WARNING**

Be sure to follow manufacturer's instructions when using the Robinair Heat Gun or any other radiant heating device. Failure to follow manufacturer's instructions can cause a fire, which could result in death or serious injury. (00379a)

- b. Apply heat with heat gun.  
Special Tool: ROBINAIR HEAT GUN (HD-25070)
- c. Peel adhesive strip from braces.

- d. Remove any remaining adhesive with adhesive remover.

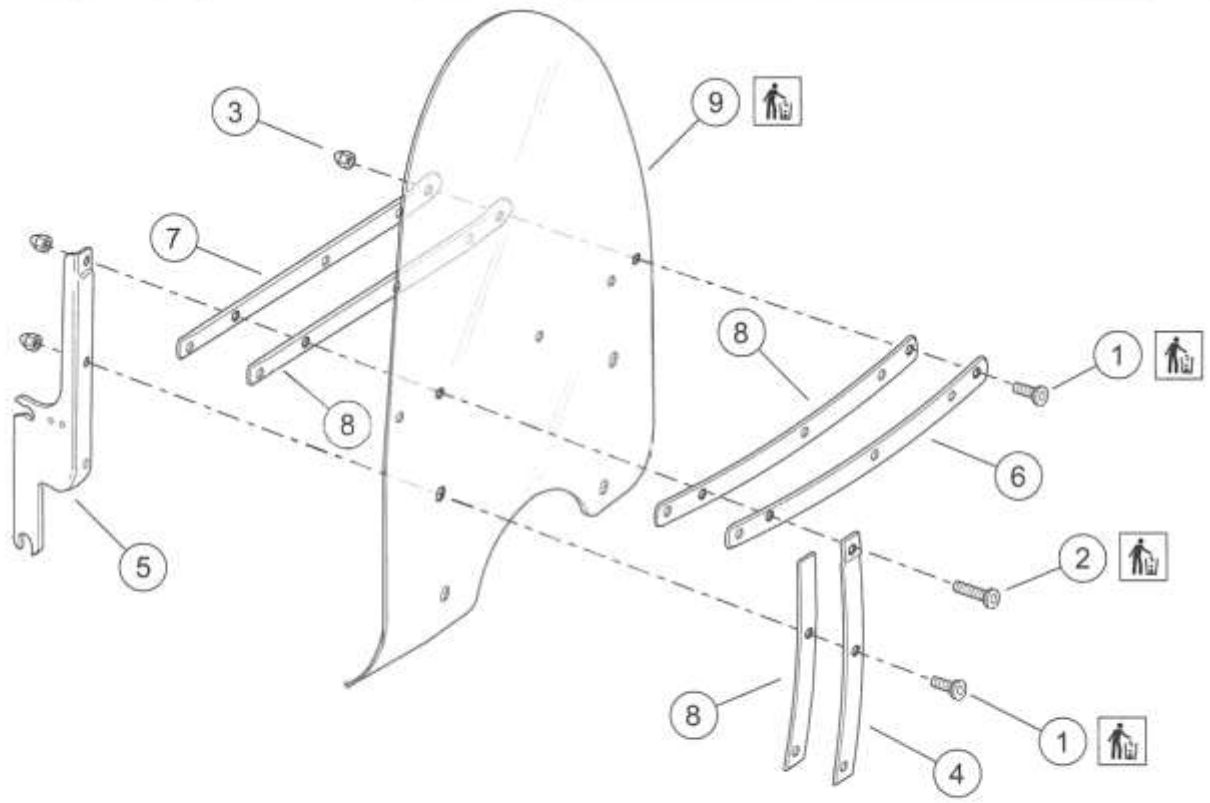
3M GENERAL PURPOSE ADHESIVE REMOVER ()

**ASSEMBLE**

1. See Figure 3-137. Remove paper backing from one side of

| FASTENER                                 | TORQUE VALUE |             |
|--|--------------|-------------|
| Windshield window screw Road King models | 20-25 in-lbs | 2.3-2.8 N-m |

- each adhesive strip (8) and apply to windshield side of each brace (4, 6, 7).
2. Place new windshield with front side down on clean padded surface.
3. Remove paper backing from adhesive strip on thicker horizontal brace (7). Align holes in brace with holes in windshield and press brace into position.
4. Turn windshield over (front side up).
5. Remove paper backing from adhesive strip on thinner horizontal brace (6). Align holes in brace with holes in windshield. Edges of inner and outer braces must be even. Press into position.
6. Install new screws (1) through the middle and outer holes of the horizontal braces. Loosely install acorn nuts (3) on rear side.
7. Remove paper backing from adhesive strip on vertical brace. With the stepped end overlapping the horizontal brace (6) and the slight bend angled outward, align holes in brace with holes in windshield. Press into position.
8. Position mounting bracket (5) on rear side of windshield with the wireform facing inboard.
9. Secure vertical brace:
  - a. Install new long screw (2) at the stepped end where the vertical brace overlaps the horizontal brace.
  - b. Install new short screws (1) in the remaining holes.
  - c. Loosely install acorn nuts.
10. Install second vertical brace and mounting bracket in a similar manner.
11. See Figure 3-138. Tighten screws in sequence.  
Torque: 20-25 in-lbs (2.3-2.8 N-m) *Windshield window screw Road King models*
12. Install windshield. See WINDSHIELD (Page 3-121).



- |                                  |                             |
|----------------------------------|-----------------------------|
| 1. Screws, short (7)             | 6. Horizontal brace (front) |
| 2. Screws, long (2)              | 7. Horizontal brace (rear)  |
| 3. Acorn nuts (9)                | 8. Two-sided adhesive strip |
| 4. Vertical brace (right side)   | 9. Windshield               |
| 5. Mounting bracket (right side) |                             |

Figure 3-137. Windshield Assembly

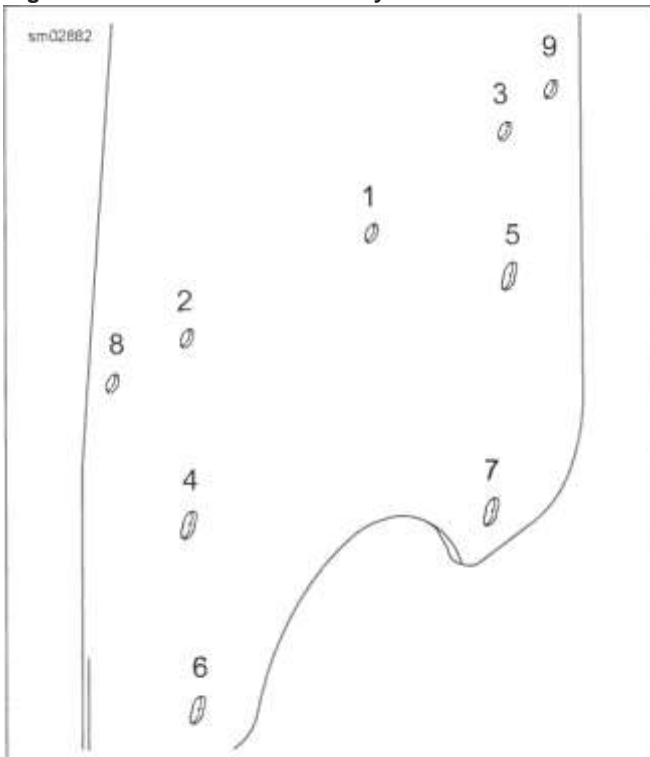


Figure 3-138. Windshield Torque Sequence



## PREPARE

1. Remove main fuse. See POWER DISCONNECT (Page 8-8).

## REMOVE AND INSTALL: STANDARD

| PART NUMBER | CONSUMABLE                          |
|-------------|-------------------------------------|
| 99839-95    | HARLEY-DAVIDSON ADHESIVE (GRIPLOCK) |

### Left Grip Removal

1. Remove left hand control module and clutch control. See LEFT HAND CONTROL MODULE (LHCM) (Page 8-22).
2. Remove left hand grip.
  - a. Cut hand grip open with a sharp knife.
  - b. Peel hand grip open.
  - c. Remove from handlebar.

### Install

1. Install left hand grip.
  - a.
  - b. Prepare left grip end of handlebar with emery cloth.  
Clean left grip end of handlebar with acetone.
    - a. A  
pply adhesive to the inside of the new hand grip.  
HARLEY-DAVIDSON ADHESIVE (GRIPLOCK) (99839-95)
    - b. Install the new hand grip with a twisting motion, ending with cosmetic features properly positioned.
2. Install left hand control module and clutch control. See LEFT HAND CONTROL MODULE (LHCM) (Page 8-22).

### Right Grip Removal

1. Remove right hand control module and front brake control. See RIGHT HAND CONTROL MODULE (RHCM) (Page 8-25).
2. Remove right hand grip.

### Install

1. Install hand grip with cosmetic features properly positioned.
  - a. Rotate to verify that internal splines are engaged with the twist grip sensor.

2. Install right hand control module and brake control. See RIGHT HAND CONTROL MODULE (RHCM) (Page 8-25).

## REMOVE AND INSTALL: HEATED

### Remove Left Grip

1. Remove outer fairing. See FAIRING: FORK MOUNTED (Page 3-89) or FAIRING: FRAME MOUNTED (Page 3-100).
2. Rotate inner fairing. See FAIRING: FORK MOUNTED (Page 3-89).
3. See Figure 3-139. Disconnect and remove terminals from heated hand grip power connector (4).
4. See Figure 3-140. Disconnect and remove terminals from heated hand grip interconnect connector (2).

#### 5. *NOTE*

*For connector service, see the electrical diagnostic manual.*

Fabricate a chaser wire approximately 91.4 cm (3 ft) long. Secure to terminals and wire leads of harness. Wrap with electrical tape.

6. Bend last few inches of free end of chaser wire into a "L" shape to prevent pulling it too far into the handlebar.

Remove left handlebar switch housing and clutch lever. Allow to hang. See LEFT HAND CONTROL MODULE (LHCM) (Page 8-22).

8. Lubricate wire harness conduits with glass cleaner.
9. Slide hand grip off end of handlebar. Grasp harnesses and pull from handlebar. Detach from chaser wire.

#### *NOTE*

*When pulling, feed opposite end of harnesses and mechanic's wire into handlebar.*

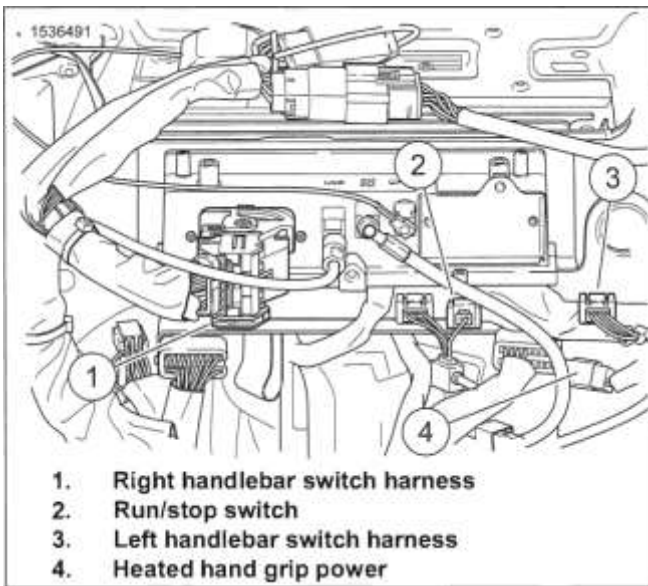


Figure 3-139. Handlebar Harness Connectors

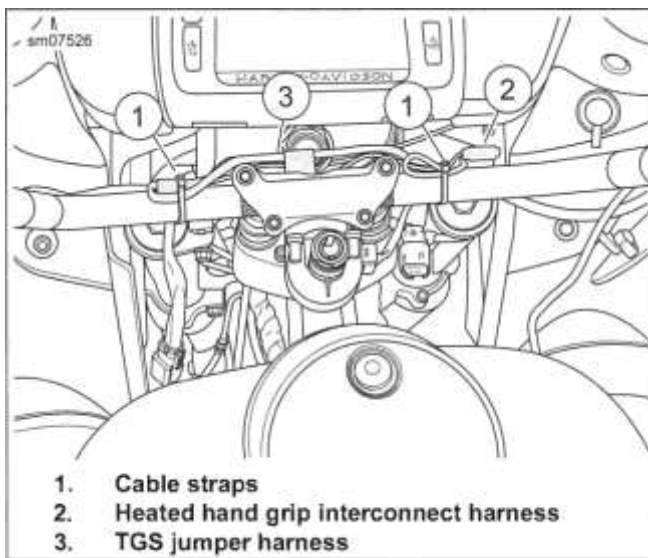


Figure 3-140. Secure Harness to Handlebar

### Install Left Grip

1. Attach chaser wire to harnesses. Wrap with electrical tape.
2. Lubricate wire harness conduits with glass cleaner.
3. Carefully feed harnesses into handlebar with one hand as they are pulled with the other.
4. Slide hand grip onto end of handlebar. Pull slack from wiring harnesses. Remove chaser wire.
5. Install terminals into connector housing cavities. See electrical diagnostic manual.
6. Mate connectors. Secure harnesses with new cable straps.

7. Install left handlebar switch housing and clutch lever. See LEFT HAND CONTROL MODULE (LHCM) (Page 8-22). Make sure rim of hand grip fits into grooves in switch housings.
8. Rotate inner fairing into position and secure. See FAIRING: FORK MOUNTED (Page 3-89).
9. Install outer fairing. See FAIRING: FORK MOUNTED (Page 3-89) or FAIRING: FRAME MOUNTED (Page 3-100).

### Remove Right Grip

#### NOTE

*This procedure covers only removal and installation of the hand grip. For service of Twist Grip Sensor (TGS), see TWIST GRIP SENSOR (TGS) (Page 6-22).*

1. Remove right switch housing and brake control. See RIGHT HAND CONTROL MODULE (RHCM) (Page 8-25).
2. Pry end cap from hand grip. Pull connector out through end of hand grip.
3. Pull hand grip off end of handlebar.

#### NOTE

*To remove the throttle hand grip, a slight tug may be necessary.*

### Install Right Grip

1. Verify twist grip sensor is properly installed in end of handlebar.
2. Seat hand grip onto twist grip sensor.
3. Using needle nose pliers, insert prongs of connector into connector holes located in end of twist grip sensor.
4. Pull hand grip off until it disengages TGS.
  - a. Rotate hand grip to allow wires to wrap around connector.
  - b. Orient hand grip to match left side and engage hand grip on TGS.
  - c. Rotate hand grip to verify proper engagement.
  - d. Install end cap.
5. Install right switch control housing and front brake master cylinder. See RIGHT HAND CONTROL MODULE (RHCM) (Page 8-25).

### COMPLETE

1. Install main fuse. See POWER DISCONNECT (Page 8-8).

**PREPARE**

1. Remove main fuse.

**REMOVE AND INSTALL: WITHOUT FAIRING**

| FASTENER                                  | TORQUE VALUE        |               |
|---|---------------------|---------------|
| Brake master cylinder, front, clamp screw | 60-80 <b>in-lbs</b> | 6.8-9 N-m     |
| Clutch lever bracket clamp screw          | 60-80 <b>in-lbs</b> | 6.8-9 N-m     |
| Handlebar upper clamp screws              | 16-20 ft-lbs        | 21.7-27.1 N-m |

**Remove***NOTE*

Cover painted surfaces to prevent scratches or other damage.

1. **FLHRXS:** Remove front turn signal lamps and mirrors. Support turn signal out of the way. See MIRRORS (Page 3-132).
2. See Figure 3-141. Separate left handlebar switch (1) and TGS (2) connectors.
3. See Figure 3-142. Separate right handlebar switch connectors (1).
4. Remove master cylinder/brake lever assembly from handlebar.
5. Remove clutch hand lever and bracket assembly from handlebar.
6. Remove handlebar clamp shroud. See HEADLAMP NACELLE (Page 3-87).
7. Remove handlebar assembly.
  - a. Remove upper handlebar clamp screws.
  - b. Remove upper handlebar clamp.
  - c. Remove handlebar assembly.

**Install**

1. Install handlebar assembly.
  - a. Install handlebar and upper clamp. Install screws finger-tight.
  - b. Center handlebars.
  - c. Snug clamp screws.
  - d. Carefully turn handlebars to full right and full left fork stops. Verify that there is no contact with the fuel tank. Adjust as necessary.

2. Tighten forward clamp screws until upper and lower handlebar clamps make contact.

3. *NOTE*

*A slight gap will exist between the upper and lower clamps at the rear of the handlebars after tightening.*

Tighten screws.

a. **Rear:**

Torque: 16-20 ft-lbs (21.7-27.1 N-m) *Handlebar upper clamp screws*

b. **Front:**

Torque: 16-20 ft-lbs (21.7-27.1 N-m) *Handlebar upper clamp screws*

4. Secure harnesses as necessary with new cable straps.
5. Install handlebar clamp shroud. See HEADLAMP NACELLE (Page 3-87).
6. Install hand brake bracket and clamp.
  - a. Engage ear in recess and rotate into position.
  - b. Install clamp and screws.
  - c. Begin with upper screw, tighten.  
Torque: 60-80 **in-lbs** (6.8-9 N-m) *Brake master cylinder, front, clamp screw*
7. Install clutch lever bracket and clamp.
  - a. Engage ear in recess and rotate into position.
  - b. Install clamp and screws.
  - c. Begin with upper screw, tighten.  
Torque: 60-80 **in-lbs** (6.8-9 N-m) *Clutch lever bracket clamp screw*
8. See Figure 3-141. Connect left handlebar switch (1) and TGS (2) connectors.
9. See Figure 3-142. Connect right handlebar switch connectors (1).
10. **FLHRXS:** Install front turn signal lamps and mirrors. See MIRRORS (Page 3-132).

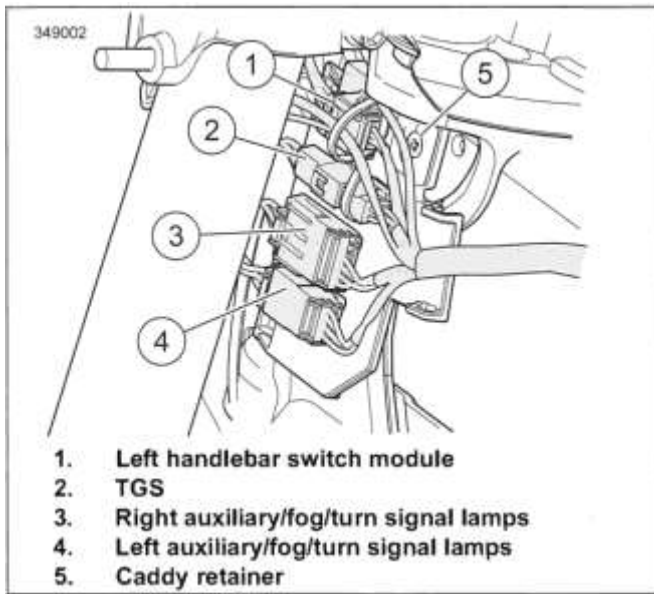


Figure 3-141. Left Side Connectors: Road King Models

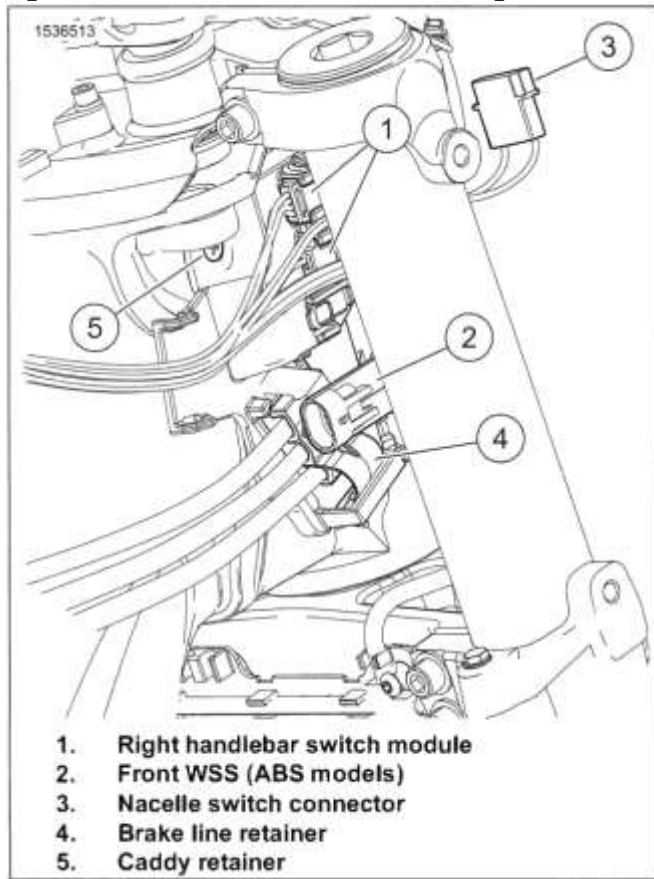


Figure 3-142. Right Side Connectors: Road King

**REMOVE AND INSTALL: FORK MOUNTED FAIRING**

| FASTENER                                  | TORQUE VALUE |               |
|---|--------------|---------------|
| Brake master cylinder, front, clamp screw | 60-80 in-lbs | 6.8-9 N-m     |
| Clutch lever bracket clamp screw          | 60-80 in-lbs | 6.8-9 N-m     |
| Handlebar upper clamp screws              | 16-20 ft-lbs | 21.7-27.1 N-m |

**Remove**

*NOTE*

*Cover painted surfaces to prevent scratches or other damage.*

1. Remove outer fairing. See FAIRING: FORK MOUNTED (Page 3-89).
2. See Figure 3-143. Separate TGS connector (14).
3. Disconnect heated hand grip power connector (17) if equipped. The hand grip interconnect harness does not require disconnection.
4. Disconnect handlebar switch connectors (6, 11, 12).
5. Remove master cylinder/brake lever assembly from handlebar.
6. Remove clutch hand lever and bracket assembly from handlebar.
7. Detach inner fairing. See FAIRING: FORK MOUNTED (Page 3-89).
8. Remove handlebar assembly.
  - a. Remove upper handlebar clamp screws.
  - b. Remove upper handlebar clamp.
  - c. Remove handlebar assembly.

**Install**

1. Install handlebar assembly.
  - a. Install handlebar and upper clamp. Install screws finger-tight.
  - b. Center handlebars.
  - c. Snug clamp screws.
  - d. Carefully turn handlebars to full right and full left fork stops. Verify that there is no contact with the fuel tank. Adjust as necessary.
2. Tighten forward clamp screws until upper and lower handlebar clamps make contact.

3. *NOTE*

*A slight gap will exist between the upper and lower clamps at the rear of the handlebars after tightening.*

Tighten screws.

- a. **Rear:**  
Torque: 16-20 ft-lbs (21.7-27.1 N-m) *Handlebar upper clamp screws*
- b. **Front:**  
Torque: 16-20 ft-lbs (21.7-27.1 N-m) *Handlebar upper clamp screws*

4. Secure harnesses as necessary with new cable straps.

5. **NOTE**

Some models use a small hand control bracket clamp while others use the large one. Make sure to install the correct one for the model being serviced. The large clamp incorporates an alignment pin that must engage a slot in the handlebar.

Secure inner fairing. See FAIRING: FORK MOUNTED (Page 3-89).

6. Install hand brake bracket and clamp.

a. Engage ear in recess and rotate into position.

b. Install clamp and screws.

c. Begin with upper screw, tighten.

Torque: 60-80 **in-lbs** (6.8-9 N-m) *Brake master cylinder, front, clamp screw*

1. **P&A audio**

2. **USB cable**

3. **AM/FM radio antenna**

4. **GPS antenna**

5. **Left handlebar switch harness**

6. **CB antenna, if equipped**

7. **Front fender tip lamp, if equipped**

8. **Main-to-fairing harness, left**

7. Install clutch lever bracket and clamp.

a. Engage ear in recess and rotate into position.

b. Install clamp and screws.

c. Begin with upper screw, tighten.

Torque: 60-80 **in-lbs** (6.8-9 N-m) *Clutch lever bracket clamp screw*

8. See Figure 3-143. Connect TGS harness (14).

9. Connect handlebar switch harness connectors (6, 11, 12).

10. Connect heated hand grip power connector (17), if equipped.

11. Install outer fairing. See FAIRING: FORK MOUNTED (Page 3-89).

9. **Ground**

10. **Run/stop switch**

11. **Right handlebar switch harness**

12. **Main-to-fairing harness, right**

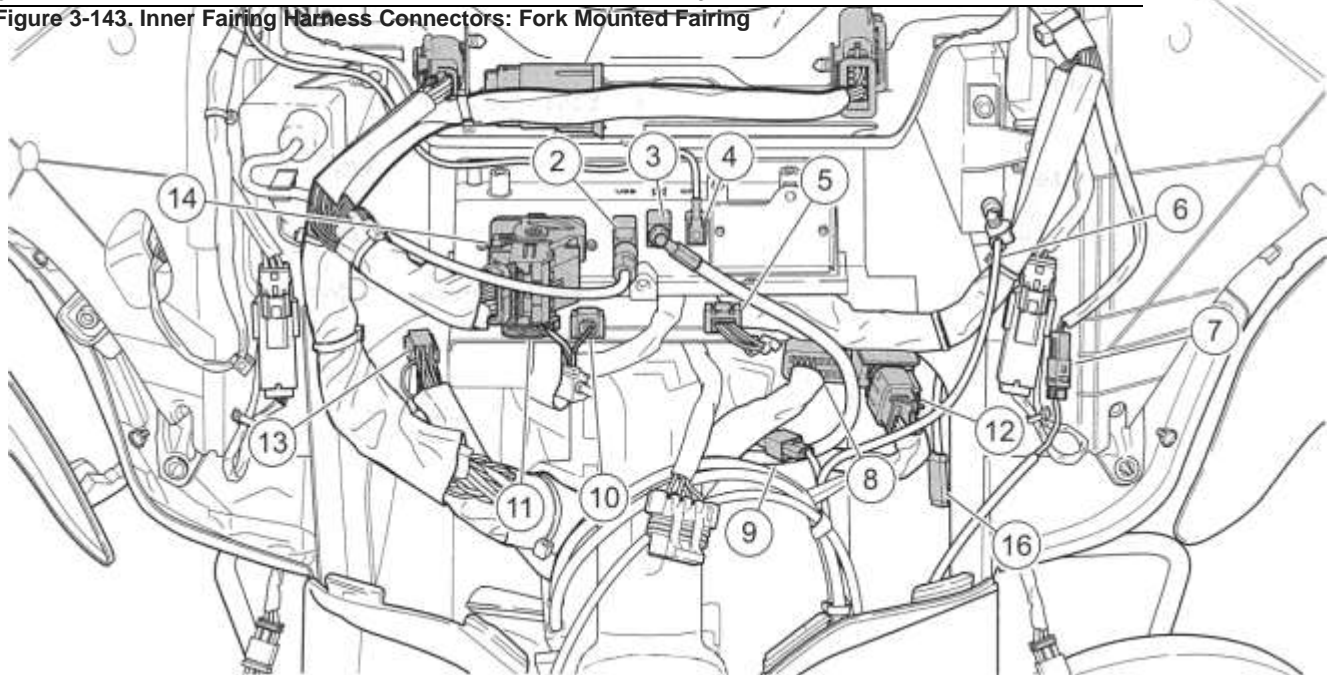
13. **TGS**

14. **Radio**

15. **Accessory power**

16. **Heated hand grip power, if equipped**

Figure 3-143. Inner Fairing Harness Connectors: Fork Mounted Fairing



A slight gap will exist between the upper and lower clamps at the rear of the handlebars after tightening.

| FASTENER                                  | TORQUE VALUE        |               |
|---|---------------------|---------------|
| Brake master cylinder, front, clamp screw | 60-80 <b>in-lbs</b> | 6.8-9 N-m     |
| Clutch lever bracket clamp screw          | 60-80 <b>in-lbs</b> | 6.8-9 N-m     |
| Handlebar upper clamp screws              | 16-20 ft-lbs        | 21.7-27.1 N-m |

## **REMOVE AND INSTALL: FRAME MOUNTED FAIRING**

### **Remove**

#### *NOTE*

Cover painted surfaces to prevent scratches or other damage.

1. Remove instrument bezel. See FAIRING: FRAME MOUNTED (Page 3-100).
2. See Figure 3-144. Separate TGS connector (1).
3. Disconnect heated hand grip power connector, if equipped. The hand grip interconnect harness does not require disconnection.
4. Disconnect handlebar switch connectors (2, 3, 4).
5. Remove master cylinder/brake lever assembly from handlebar.
6. Remove clutch hand lever and bracket assembly from handlebar.
7. Remove handlebar assembly.
  - a. Remove upper handlebar clamp screws.
  - b. Remove upper handlebar clamp.
  - c. Remove handlebar assembly.

### **Install**

1. Install handlebar assembly.
  - a. Install handlebar and upper clamp. Install screws finger-tight.
  - b. Center handlebars.
  - c. Snug clamp screws.
  - d. Carefully turn handlebars to full right and full left fork stops. Verify that there is no contact with the fuel tank. Adjust as necessary.
2. Tighten forward clamp screws until upper and lower handlebar clamps make contact.
3. *NOTE*

Tighten screws.

a. **Rear:**

Torque: 16-20 ft-lbs (21.7-27.1 N-m) *Handlebar upper clamp screws*

b. **Front:**

Torque: 16-20 ft-lbs (21.7-27.1 N-m) *Handlebar upper clamp screws*

4. Secure harnesses as necessary with new cable straps.

5. Install hand brake bracket and clamp.

a. Engage ear in recess and rotate into position.

b. Install clamp and screws.

c. Begin with upper screw, tighten.

Torque: 60-80 **in-lbs** (6.8-9 N-m) *Brake master cylinder, front, clamp screw*

6. Install clutch lever bracket and clamp.

a. Engage ear in recess and rotate into position.

b. Install clamp and screws.

c. Begin with upper screw, tighten.

Torque: 60-80 **in-lbs** (6.8-9 N-m) *Clutch lever bracket clamp screw*

7. See Figure 3-144. Connect TGS harness (1).

8. Connect handlebar switch harness connectors (2, 3, 4).

9. Connect heated hand grip power connector, if equipped.

10. Install instrument bezel. See FAIRING: FRAME MOUNTED (Page 3-100).

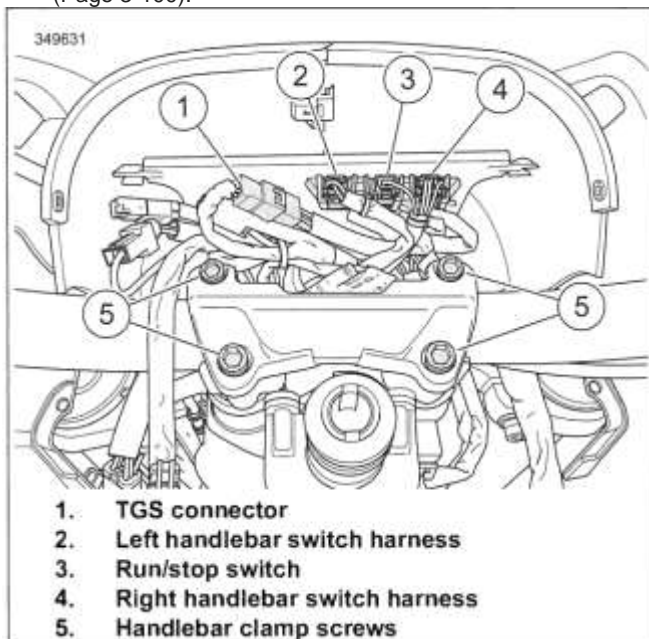


Figure 3-144. Handlebar Harness Connectors: Frame-Mounted Fairing Models

# DISASSEMBLE AND ASSEMBLE

| FASTENER | TORQUE VALUE |
|----------|--------------|
|----------|--------------|

| PART NUMBER | CONSUMABLE  |
|-------------|---|
| 99642-97    | LOCTITE 243 MEDIUM STRENGTH<br>THREADLOCKER AND SEALANT<br>(BLUE) |

## Disassemble

### NOTE

- Due to room constraints, remove harnesses one side at a time.
- Harnesses can be replaced with handlebar installed or removed. If only one side requires service, perform the appropriate steps.

1. Remove instrument bezel. See FAIRING: FRAME MOUNTED (Page 3-100).
2. Disconnect TGS connector [204] and all handlebar switch harness connectors [22, 24].
3. **FLHRXS:** Disconnect front turn signal lamp connectors.
4. Disconnect heated grip power connector [189] and interconnect [206] connector, if equipped.
5. Remove cable straps and note location for installation.
6. **NOTE**  
*Removal of the handlebar switch module connector terminals is not required however, doing so makes removal and installation easier*  
  
Attach chaser wires.
  - a. Cut a length of chaser wire for each harness.
  - b. Attach chaser wire to the end of each harness.
  - c. Wrap end of each wiring harness and chaser wire tightly with electrical tape.
7. Remove handlebar switch packs. Do not disconnect switch pack harnesses unless they require replacement. See LEFT HAND CONTROL MODULE (LHCM) (Page 8-22) or RIGHT HAND CONTROL MODULE (RHCM) (Page 8-25).
8. Remove right grip.
9. Lightly lubricate conduits and tape with glass cleaner.
10. Pull TGS harness out of handlebar, along with the right switch control harness.
11. Pull left switch control harness out of handlebar.
12. Remove chaser wires from harnesses. Leave the chaser wire in the handlebar for installation.

- Lower Risers  
13. See Figure 3-146. Remove bolts (9) and riser components.

## Assemble

### Lower Risers

1. See Figure 3-146. Install handlebar risers.

- a. Install riser components.
- b. Apply threadlocker to threads of bolts (9).

LOCTITE 243 MEDIUM STRENGTH  
THREADLOCKER AND SEALANT (BLUE) (99642-97)

- c. Install bolts (9). Tighten.

Torque: 30.0-40.0 ft-lbs (40.7-54.2 N-m)

### NOTE

- Install harnesses one side at a time.
  - Feed harnesses into handlebar as chaser wire is pulled.
2. If installing **new** handlebar, cut length of chaser wire for each harness.
    - a. Feed one chaser wire through hole near left end of handlebar.
    - b. Feed one chaser wire through hole near right end of handlebar and one through right end of handlebar tube.
    - c. Extract ends of all chaser wires through center hole.
  3. Attach chaser wires:
    - a. **Left side:** Attach chaser wire extending from hole to left switch control harness.
    - b. **Right side:** Attach chaser wire extending from right end of handlebar tube to TGS harness. Attach chaser wire extending from hole to right switch control harness.
    - c. Wrap chaser wires and terminals of each harness tightly with electrical tape.
  4. Install harnesses.
    - a. Lubricate harnesses with glass cleaner.
    - b. Pull harnesses to the handlebar center hole until TGS is fully seated. Pull switch harnesses until no slack exists.
    - c. Install switch control housings and grip. See LEFT HAND CONTROL MODULE (LHCM) (Page 8-22) or RIGHT HAND CONTROL MODULE (RHCM) (Page 8-25).
    - d. Remove slack in harnesses. Remove tape and chaser wires.



5. See Figure 3-145. Secure TGS harness.
  - a. Fold TGS harness onto itself.
  - b. Install **new** cable strap (2).
6. Connect heated grip power connector and interconnect connector, if equipped.
7. Connect TGS connector [204] and all handlebar switch harness connectors [22, 24].
8. **FLHRXS:** Connect front turn signal lamp connectors.
9. Install instrument bezel. See FAIRING: FRAME MOUNTED (Page 3-100).

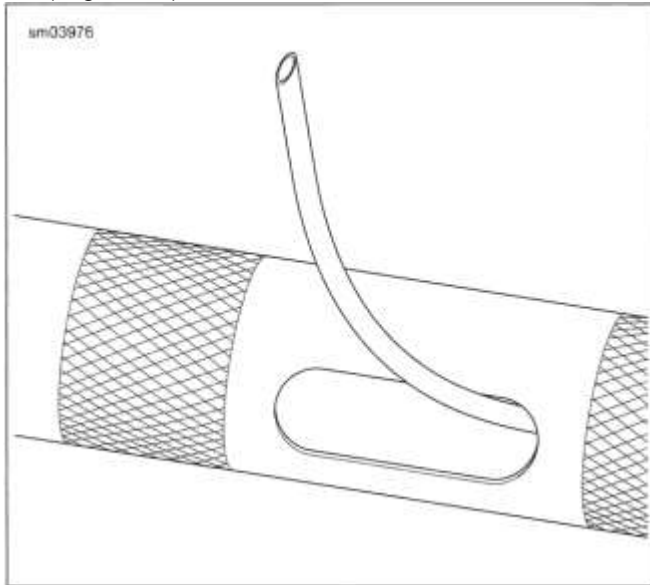
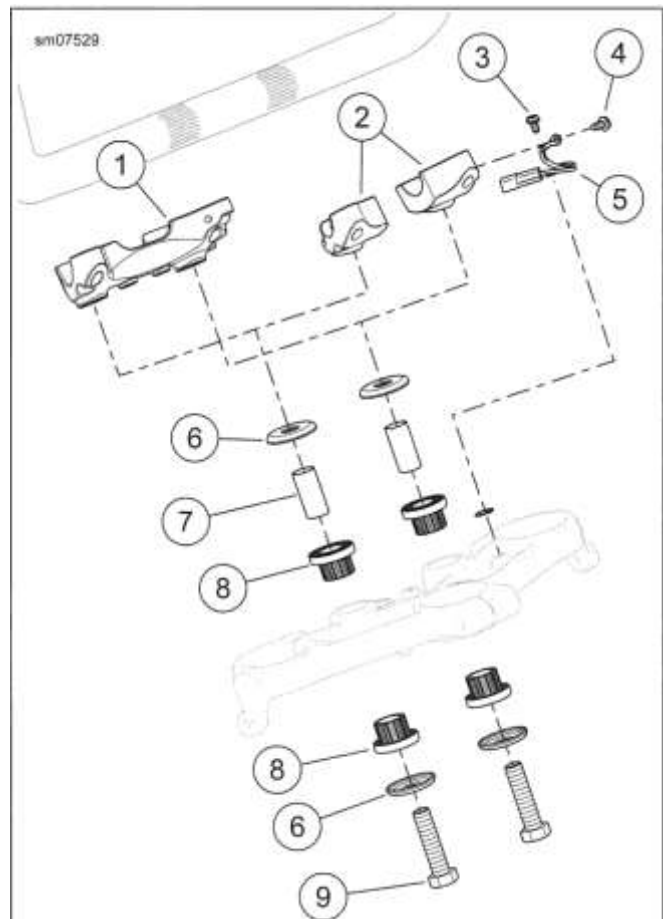


Figure 3-145. Wire Leader through Center of Handlebar



1. Handlebar lower clamp (frame mounted fairing)
2. Handlebar lower clamp (2) (all except frame mounted fairing)
3. Fork bracket ground screw
4. Lower clamp ground screw
5. Ground jumper wire assembly
6. Cup washer (4)
7. Spacer (2)
8. Rubber bushing (4)
9. Bolt (2)

Figure 3-146. Handlebar Mounts

### ADJUST

| APPLICABILITY                |                                   |               |
|------------------------------|-----------------------------------|---------------|
| 0                            | • 2021 ROAD KING SPECIAL (FLHRXS) |               |
| FASTENER                     | TORQUE VALUE                      |               |
| Handlebar upper clamp screws | 16-20 ft-lbs                      | 21.7-27.1 N-m |

### Road King Special (FLHRXS)

1. See Figure 3-147. Check handlebar angle to verify that the height above the seat is 15 in (38.1 cm) or less.
  - a. Place a straightedge parallel to the fork.
  - b. Check that angle (A) is 17 degrees or greater. Adjust as necessary.

## NOTICE

Using excessive force to adjust handlebar can result in damage to handlebar or clamp. (00444b)

2. Adjust handlebar angle.
  - a. See Figure 3-148. Remove decorative plate.
  - b. See Figure 3-149. Loosen handlebar upper clamp screws.
  - c. Rotate handlebar to specification.
3. Tighten upper handlebar clamp screws.

Torque: 16-20 ft-lbs (21.7-27.1 N-m) *Handlebar upper clamp screws*
4. Install decorative plate.
5. Slowly rotate handlebar from stop to stop to verify there is no contact with fuel tank.

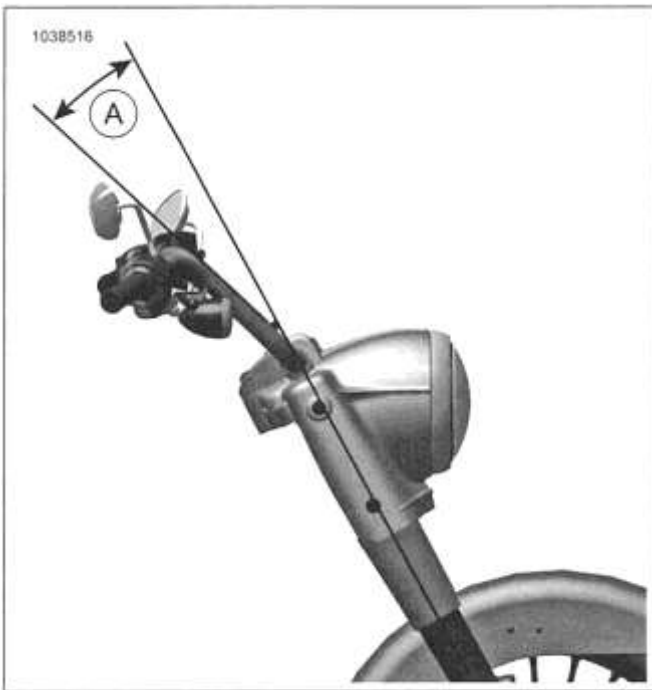


Figure 3-147. Handlebar Angle: FLHRXS

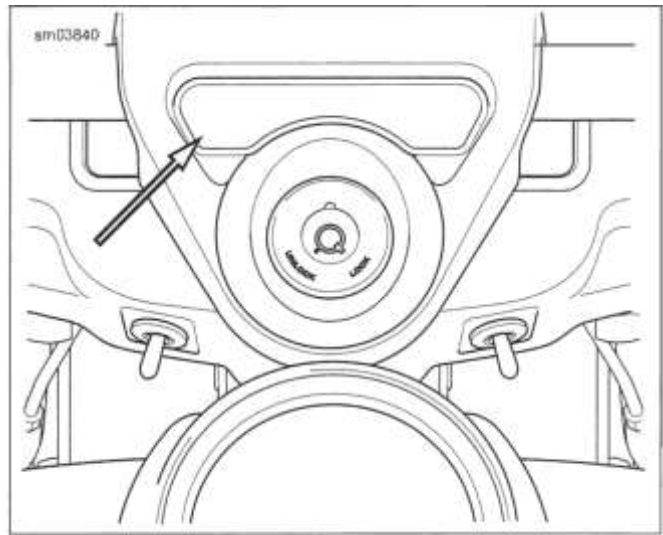


Figure 3-148. Decorative Plate: Road King

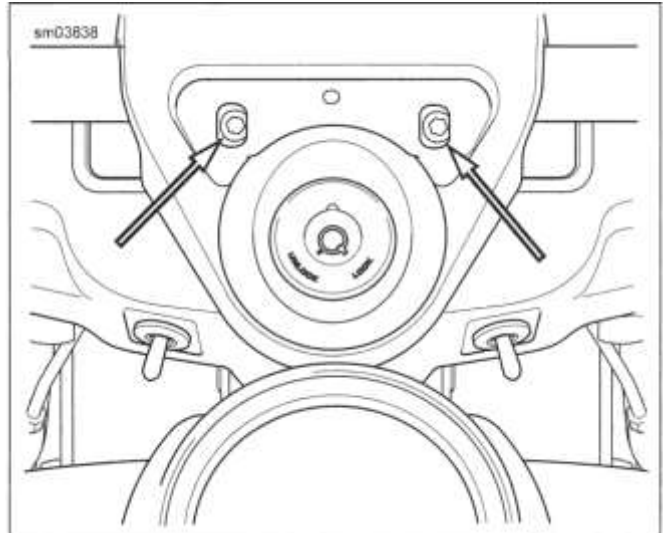


Figure 3-149. Loosen Upper Handlebar Clamp Screws:  
Road King

## COMPLETE

1. Install main fuse.

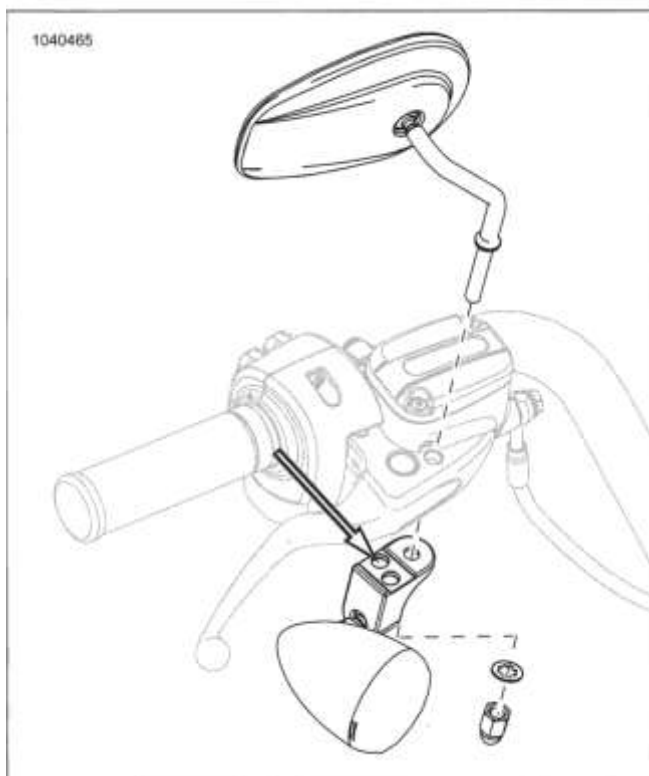
| FASTENER              | TORQUE VALUE   |               |
|-----------------------|----------------|---------------|
| Mirror stem acorn nut | 120-144 in-lbs | 13.6-16.3 N-m |

**Remove**

1. See Figure 3-150. Remove acorn nut (1) and lockwasher (2).
2. Remove mirror (3).
3. **FLHRXS:** Support turn signal lamp out of the way.

**Install**

1. Insert threaded stem of mirror into hole in clutch or brake lever bracket.
2. **FLHRXS:** See Figure 3-151. Install turn signal lamp.
  - a. Position turn signal lamp on mirror stem.
  - b. Verify that hand lever pivot pin is in recess in lamp mount.
3. Install lockwasher and acorn nut.
4. Adjust mirror as necessary and tighten acorn nut.  
 Torque: 120-144 **in-lbs** (13.6-16.3 N-m) *Mirror stem acorn nut*
5. **FLHRXS:** Verify that turn signal lamp is aligned straight forward.



**Figure 3-151. Mirror and Turn Signal Lamp: FLHRXS**

**REMOVE AND INSTALL: FAIRING MOUNT**

| FASTENER                       | TORQUE VALUE |             |
|--------------------------------|--------------|-------------|
| Fork-mounted mirror flange nut | 20-30 in-lbs | 2.3-3.4 N-m |

**Prepare**

1. Remove outer fairing. See FAIRING: FORK MOUNTED (Page 3-89).

**Remove**

1. See Figure 3-153. Remove flange nut (4) and backing plate (3). Remove mirror.

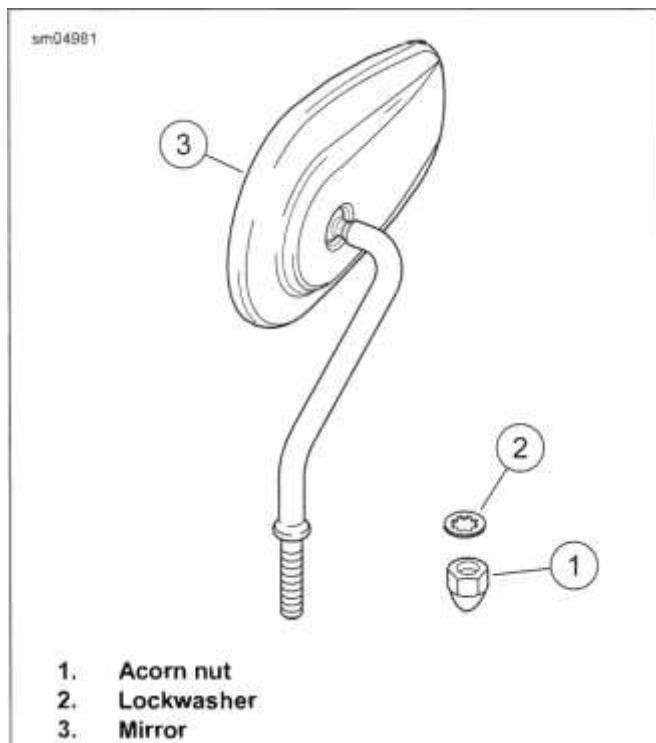
**Install**

**NOTE**

See Figure 3-152 and Figure 3-153. The letters "L" or "R" are stamped on the backing plate and inner fairing to identify location.

1. See Figure 3-153. With the bar and shield logo on mirror right-side-up, insert threaded stud and align index pin (2) with hole in inner fairing.
2. Install the backing plate (3) engaging the hole with index pin (2).
3. Install flange nut (4). Tighten.

Torque: 20-30 **in-lbs** (2.3-3.4 N-m) *Fork-mounted mirror flange nut*



**Figure 3-150. Mirror Assembly (All Models Except FLHX)**

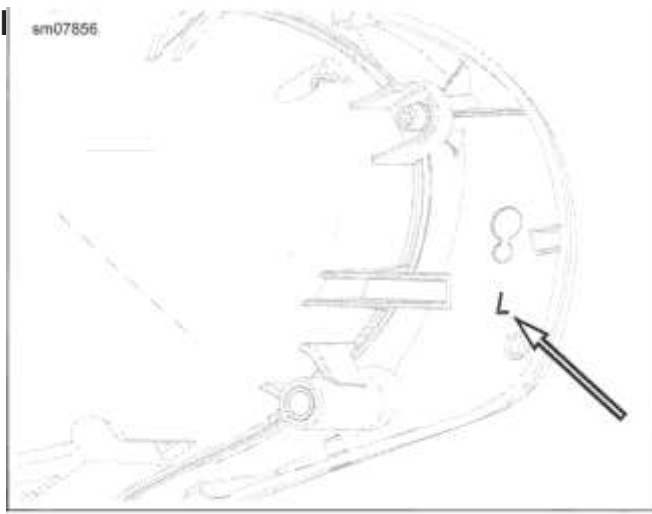
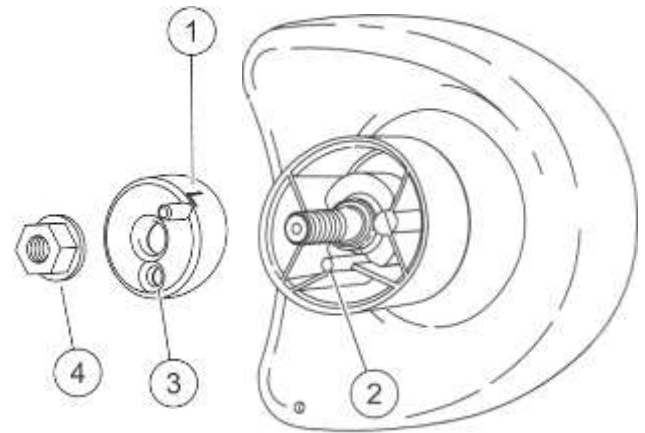


Figure 3-152. Mirror Location Mark



1. Identification
2. Index pin
3. Backing plate
4. Flange nut

Figure 3-153. Mirror Assembly, typical (FLHX/S)

### Complete

1. Install outer fairing. See FAIRING: FORK MOUNTED (Page 3-89).

## REMOVE

1. See Figure 3-154. Remove outer fairing and disconnect fender tip lamp connector, if equipped. See FAIRING: FORK MOUNTED (Page 3-89) or FAIRING: FRAME MOUNTED (Page 3-100).
2. Remove cable straps as necessary.
3. Draw connector housing down to fender area.
4. See Figure 3-155. Remove screws (1). Remove fender.

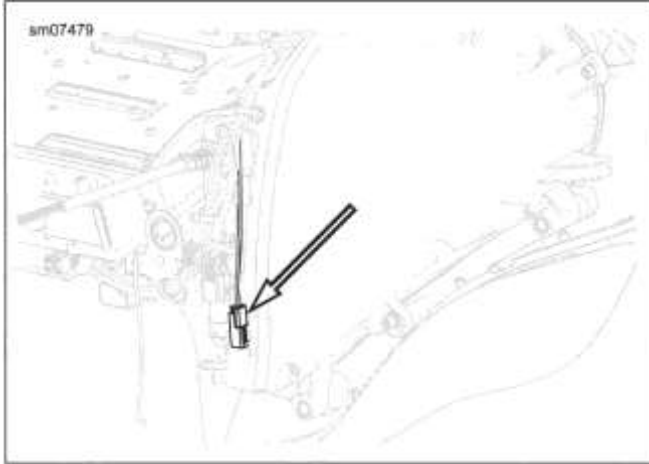


Figure 3-154. Front Fender Tip Lamp Connector  
**INSTALL** <sup>7 8</sup>

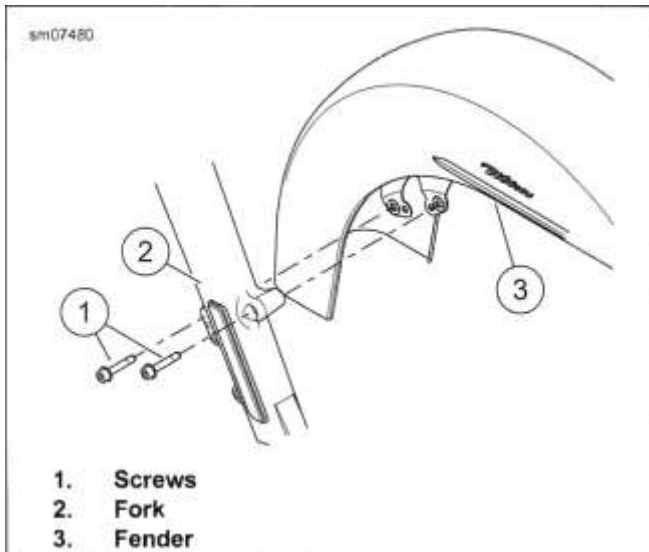


Figure 3-155. Front Fender Fasteners

| FASTENER                    | TORQUE VALUE                |
|-----------------------------|-----------------------------|
| Front fender mounting screw | 16-20 ft-lbs 121.7-27.1 N-m |

### NOTE

8 The contact area of the fork and fender mounting surfaces must be free from any paint or foreign substance. It must be metal-to-metal contact. Paint or debris in this area can result in loosening of fastener torque.

- If reusing the screws, apply **LOCTITE 243 MEDIUM STRENGTH THREADLOCKER AND SEALANT (blue)** to properly cleaned screws.
- If fender is being installed as part of a fork or wheel installation, tighten fender screws after all other components are installed.
- If fender appears twisted or misaligned, loosen screws and retighten.

1. Install fender on fork sliders and start screws. Tighten.

Torque: 16-20 ft-lbs (21.7-27.1 N-m) *Front fender mounting screw*

2. See Figure 3-156. If equipped with fender tip lamp:
  - a. Mate connector. Secure harness with two new cable straps (1).
  - b. Install outer fairing. See FAIRING: FORK MOUNTED (Page 3-89) or FAIRING: FRAME MOUNTED (Page 3-100).

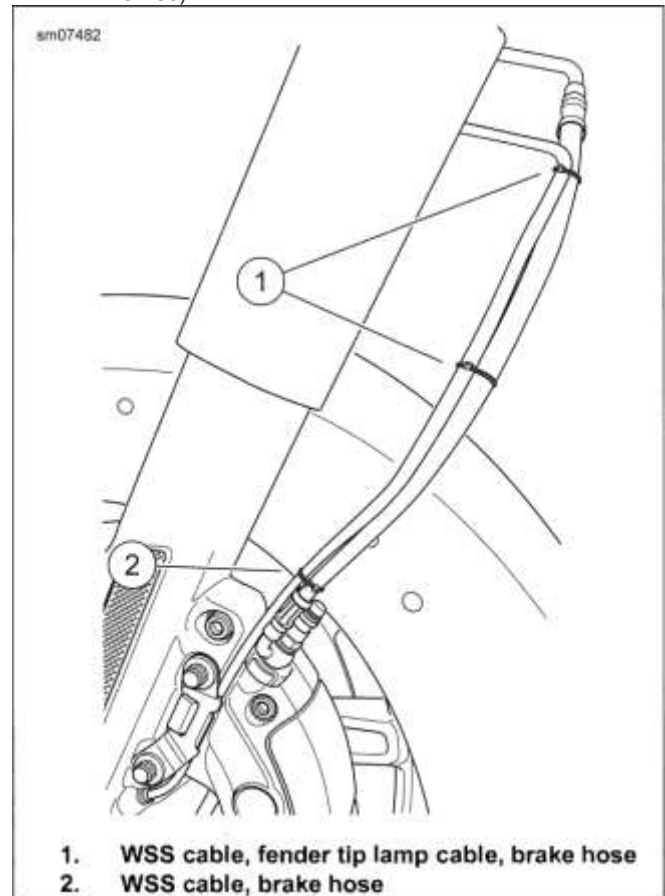


Figure 3-156. Secure Cables and Brake Hose

## DISASSEMBLE

1. See Figure 3-158. Remove fender tip (8).
  - a. Remove screws (7).
  - b. **If equipped:** Fender tip lamp (5). See FRONT FENDER TIP LAMP (Page 8-52).

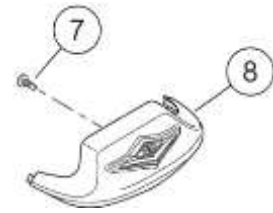
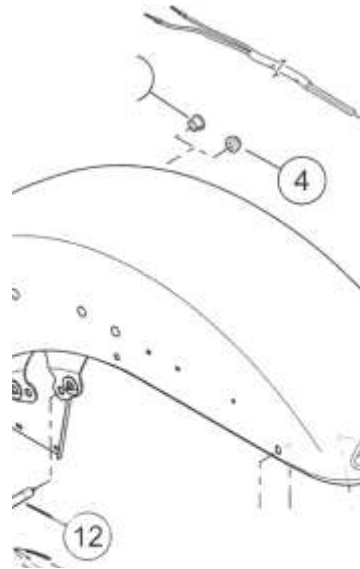
2. Remove trim (11).
  - a. Remove locknuts (9) and T-bolts (10).
3. Remove trim skirt (14).
  - a. Remove nuts (13) and screws (15).
4. Remove nameplate (1).
  - a. **With retaining clips:** Remove retaining clips (2).
  - b. **With adhesive backing:** See MEDALLIONS, BADGES, TANK EMBLEMS AND ADHESIVE STRIPS (Page 3-167).
5. Remove plug (3) and grommet (4).

**ASSEMBLE** \_\_\_\_\_

| FASTENER                    | TORQUE VALUE        |             |
|-----------------------------|---------------------|-------------|
| Front fender tip screw      | 20-25 <b>in-lbs</b> | 2.3-2.8 N-m |
| Front fender trim nut       | 10-15 <b>in-lbs</b> | 1.1-1.7 N-m |
| Front fender trim skirt nut | 10-15 <b>in-lbs</b> | 1.1-1.7 N-m |

1. See Figure 3-157. Install plug (3) and grommet (4).

2. Install nameplate (1).
  - a. **With retaining clips:** Install retaining clips (2).
  - b. **With adhesive backing:** See Figure 3-158 and MEDALLIONS, BADGES, TANK EMBLEMS AND ADHESIVE STRIPS (Page 3-167).
3. Install trim skirt (14).
  - a. Install nuts (13) and screws (15).  
Torque: 10-15 **in-lbs** (1.1-1.7 N-m) *Front fender trim skirt nut*
4. Install trim (11).
  - a. Install locknuts (9) and T-bolts (10).  
Torque: 10-15 **in-lbs** (1.1-1.7 N-m) *Front fender trim nut*
5. Install fender tip (8).
  - a. Install screws (7).  
Torque: 20-25 **in-lbs** (2.3-2.8 N-m) *Front fender tip screw*
  - b. **If equipped:** Fender tip lamp (5). See FRONT FENDER TIP LAMP (Page 8-52).



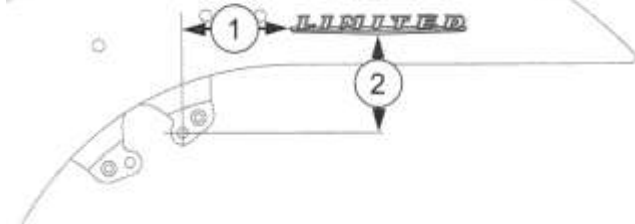
- |                       |                |
|-----------------------|----------------|
| 1. Nameplate          | 9. Locknut (4) |
| 2. Retaining clip (6) | 10. T-bolt (4) |
| 3. Plug               | 11. Trim (2)   |
| 4. Grommet            | 12. Screw (4)  |
| 5. Fender tip lamp    | 13. Nut(6)     |
| 6. Nut (2)            | 14. Trim skirt |
| 7. Screw (2)          | 15. Screw (6)  |
| 8. Fender tip         |                |

Figure 3-157. Front Fender

1383273

1. Distance: 3.29 in(83.57 mm)
2. Distance: 3.03 in (76.96 mm)

Figure 3-158. Nameplate Placement



## PREPARE

1. Remove seat. See SEAT (Page 3-148).
2. Remove saddlebags. See SADDLEBAGS (Page 3-161).
3. **All except FLHX, FLHXS, FLTRX, FLTRXS, FLHRXS:**  
See Figure 3-159. Disconnect rear lighting connector from front of fender. Release connector from fender.
4. **FLHX, FLHXS, FLTRX, FLTRXS, FLHRXS:** See Figure 3-160 and Figure 3-161. Remove shield and disconnect lights harness from rear fascia lamp. Release lights harness from retainers on left fascia and left saddlebag support casting.
5. If equipped, remove Tour-Pak and Tour-Pak support. See TOUR-PAK (Page 3-153).
6. Remove saddlebag supports and support castings. See SADDLEBAG SUPPORTS (Page 3-165).

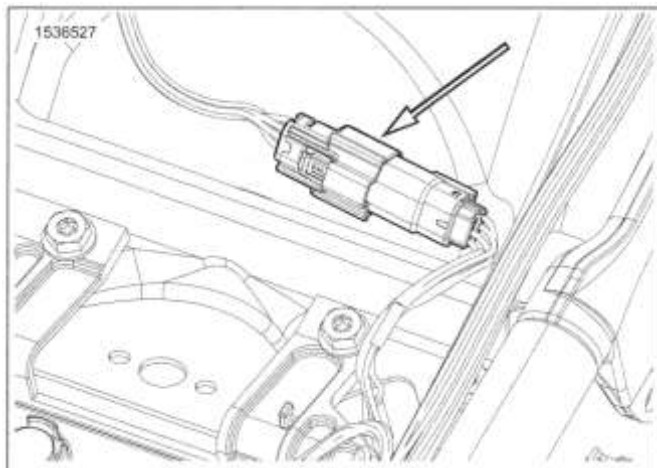


Figure 3-159. Rear Fender Lights Connector (models with under fender wiring)

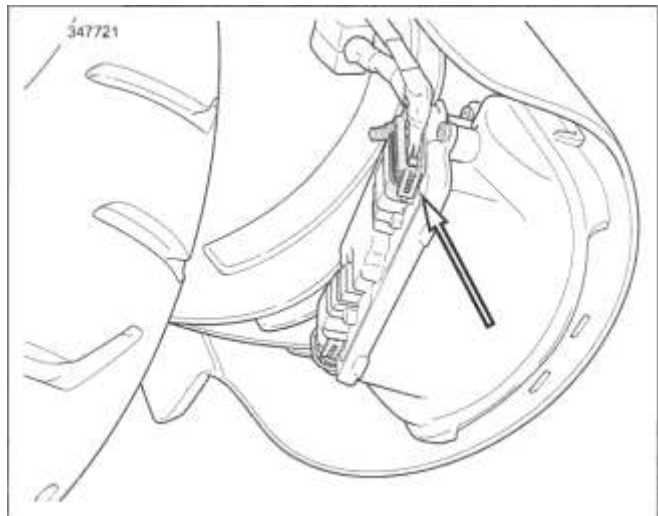


Figure 3-160. Rear Fender Lights Connector: FLHX, FLHXS, FLTRX, FLTRXS

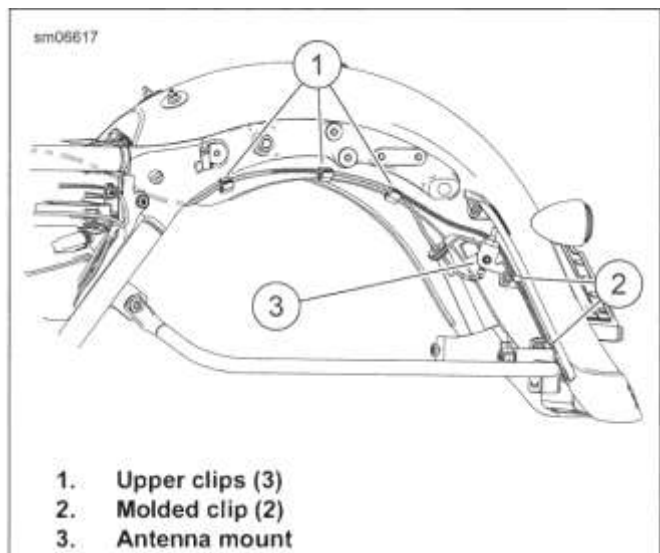


Figure 3-161. Rear Fender Lamps Harness and Antenna Cable: FLHX, FLHXS, FLTRX, FLTRXS

## REMOVE

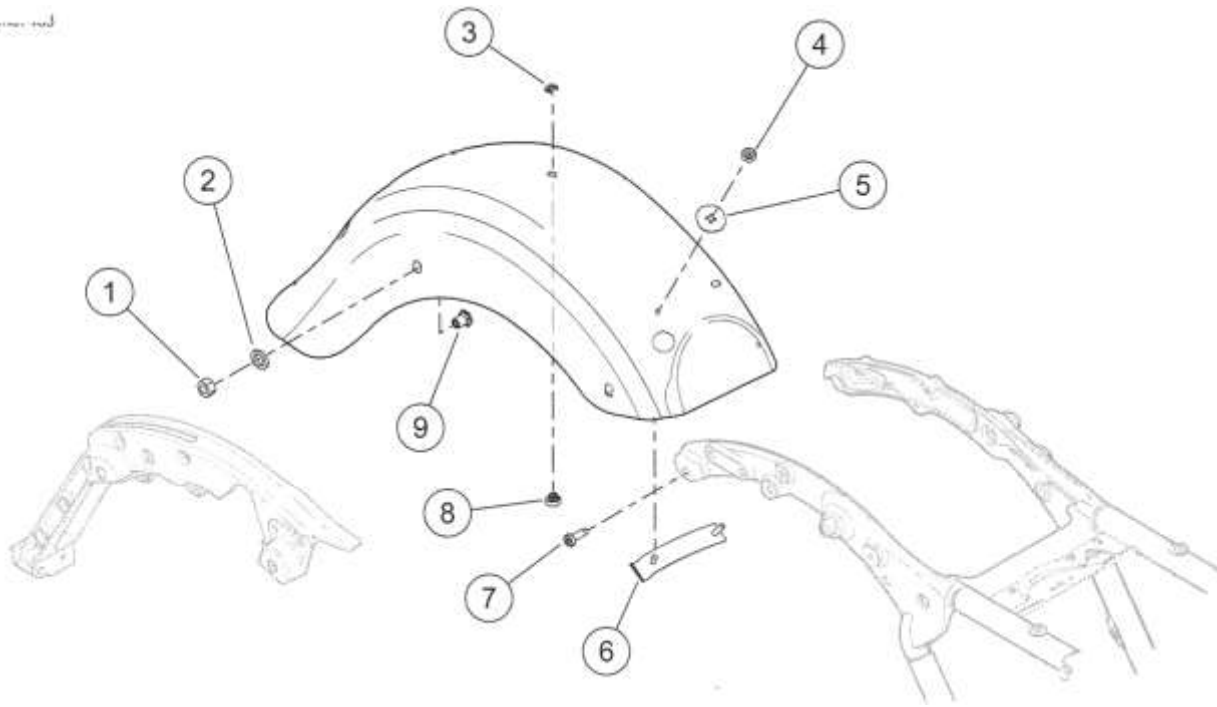
1. See Figure 3-162. Remove fender mounting screws (7) from both sides. Fender drops when screws are removed.
2. Carefully roll fender back and out of frame.

## INSTALL

| FASTENER                   | TORQUE VALUE               |
|----------------------------|----------------------------|
| Rear fender mounting screw | 15-20 ft-lbs 1 20.3-27 N-m |

1. Carefully install fender into frame.
2. See Figure 3-162. Install screws (7) on both sides.  
Torque: 15-20 ft-lbs (20.3-27 N-m) *Rear fender mounting screw*





- 1. Nut(4)
- 2. Washer (4)
- 3. Retaining ring
- 4. Flange nut
- 5. Nylon washer

- 6. Stud plate
- 7. Screw, fender to rear frame (4)
- 8. Seat retention nut
- 9. Mounting boss (4)

Figure 3-162. Rear Fender

**DISASSEMBLE**

**Mounting Hardware**

1. See Figure 3-162. Remove nut (1), washer (2) and mounting boss (9).

**Stud Plate**

1. See Figure 3-162. Remove flange nuts (4).
2. Remove nylon washers (5) and stud plate (6).

**Lights and Harnesses**

1. **All except FLHX, FLHXS, FLTRX, FLTRXS, FLHRXS:**  
For service of the tail lamps or harness, see TAIL LAMP (Page 8-59) and REAR TURN SIGNAL LAMPS (Page 8-54).
2. **FLHX, FLHXS, FLTRX, FLTRXS, FLHRXS:** For service of the rear fascia or fascia lamp, see REAR FENDER TIP LAMP (Page 8-61). For service of the tail lamps or harness, see TAIL LAMP (Page 8-59) and REAR TURN SIGNAL LAMPS (Page 8-54).

**ASSEMBLE**

**Mounting Hardware**

1. See Figure 3-162. Install nut (1), washer (2) and mounting boss (9).  
  
Torque: 15-20 ft-lbs (20.3-27.1 N-m) *Rear fender mounting nut*

**Stud Plate**

1. See Figure 3-162. Install nylon washers (5) and stud plate (6).
2. Install flange nuts (4).  
  
Torque: 60-96 in-lbs (6.8-10.8 N-m) *Rear fender stud plate nut*

**Lights and Harnesses**

1. **All except FLHX, FLHXS, FLTRX, FLTRXS, FLHRXS:**  
For service of the tail lamps or harness, see TAIL LAMP (Page 8-59) and REAR TURN SIGNAL LAMPS (Page 8-54).
2. **FLHX, FLHXS, FLTRX, FLTRXS, FLHRXS:** For service of the rear fascia or fascia lamp, see REAR FENDER TIP LAMP (Page 8-61). For service of the tail lamps or harness, see TAIL LAMP (Page 8-59) and REAR TURN SIGNAL LAMPS (Page 8-54).

| FASTENER                   | TORQUE VALUE |               |
|----------------------------|--------------|---------------|
| Rear fender mounting nut   | 15-20 ft-lbs | 20.3-27.1 N-m |
| Rear fender stud plate nut | 60-96 in-lbs | 6.8-10.8 N-m  |

**COMPLETE**

1. Install saddlebag supports and support castings. See SADDLEBAG SUPPORTS (Page 3-165).

## REAR FENDER WIRE CONDUIT

2. If equipped, install Tour-Pak and Tour-Pak support. See TOUR-PAK (Page 3-153).

3.41

3. FLHX, FLHXS, FLTRX, FLTRXS, FLHRXS: See Figure 3-160 and Figure 3-161. Route light harness through retainers on left fascia and left saddlebag support casting. Install shield and connect lights harness to rear fascia lamp.
4. All except FLHX, FLHXS, FLTRX, FLTRXS, FLHRXS: See Figure 3-159. Route connector through fender. Connect rear lighting connector to front fender.
5. Install saddlebags. See SADDLEBAGS (Page 3-161).
6. Install seat. See SEAT (Page 3-148).

## PREPARE

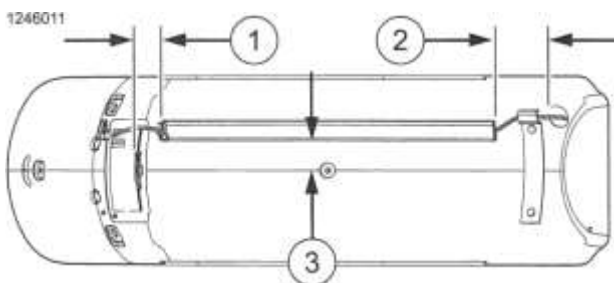
1. Remove rear fender. See REAR FENDER (Page 3-137)..
2. Remove rear fender wire harness. See electrical diagnostic manual.
  - a. Remove wire terminals from harness connectors.
  - b. Remove wire harness from conduit.

## REMOVE

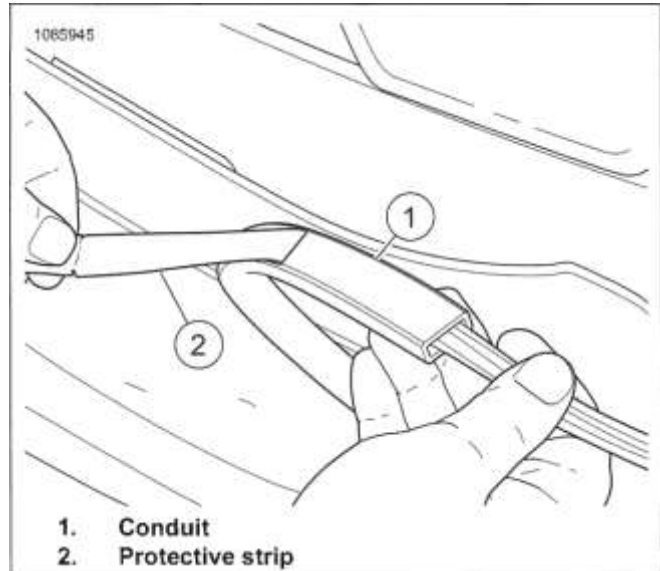
1. Remove conduit.
  - a. Pull conduit from fender.
  - b. Thoroughly clean inside surface of fender with soap and water until it is free of dirt, oil or other debris.

## INSTALL

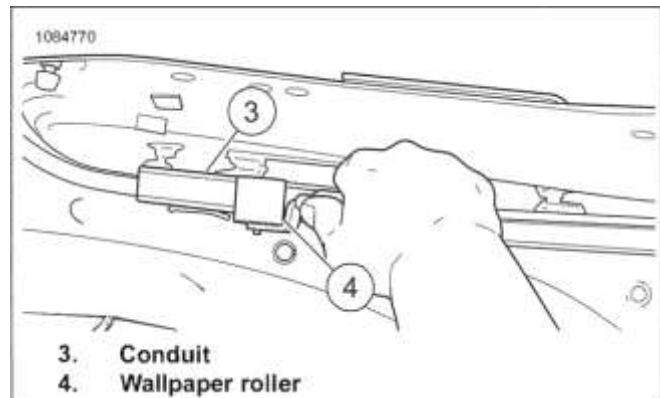
1. See Figure 3-163. Install wiring conduit.
  - a. Clean mounting surface. See MEDALLIONS, BADGES, TANK EMBLEMS AND ADHESIVE STRIPS (Page 3-167).
  - b. With adhesive backing still in place, test fit conduit.
  - c. See Figure 3-164 and Figure 3-165. Remove the adhesive backing (2).
  - d. Lightly position the conduit (1) in place.
  - e. Using a wallpaper roller (4), roll along conduit (3) to purge the air from between adhesive and fender.



1. Distance 0.88 in (22 mm)
  2. Distance 2.00 in (51 mm)
  3. Distance 1.43 in (36 mm)
- Figure 3-163. Fender Conduit Placement**



**Figure 3-164. Removing Protective Strip From Conduit**



**Figure 3-165. Purging Air Between Adhesive and Fender**

## COMPLETE

1. Install wiring harness.
  - a. Slide wiring harness through new conduit.
  - b. Install wire terminals into connector housings. See the electrical diagnostic manual.
2. Install connectors to proper component and install rear fender. See REAR FENDER (Page 3-137)

# REAR FENDER WIRE CONDUIT REAR LICENSE PLATE BRACKET

3.41  
3.42

## PREPARE

1. Remove left saddlebag. See SADDLEBAGS (Page 3-161).
2. Remove left side cover. See LEFT SIDE COVER (Page 3-62).
3. Remove main fuse. See POWER DISCONNECT (Page 8-8).

## REMOVE

1. **Turn signal bracket mounted:** See REAR TURN SIGNAL LAMPS (Page 8-54)
2. **Tour-Pak support mounted:** See TOUR-PAK (Page 3-153).

## INSTALL

1. **Turn signal bracket mounted:** See REAR TURN SIGNAL LAMPS (Page 8-54).

2. **Tour-Pak support mounted:** See TOUR-PAK (Page 3-153).

## DISASSEMBLE

1. See REAR TURN SIGNAL LAMPS (Page 8-54).

## ASSEMBLE

1. See REAR TURN SIGNAL LAMPS (Page 8-54).

## COMPLETE

1. Install main fuse. See POWER DISCONNECT (Page 8-8).
2. Install left side cover. See LEFT SIDE COVER (Page 3-62).
3. Install left saddlebag. See SADDLEBAGS (Page 3-161).

**PREPARE**

1. Set motorcycle upright. See *Secure the Motorcycle for Service* (Page 2-3).

**REMOVE**

3.

Remove footboard and bracket assembly.

**NOTICE**

When lifting a motorcycle using a jack, be sure jack contacts both lower frame tubes where down tubes and lower frame tubes converge. Never lift by jacking on cross-members, oil pan, mounting brackets, components or housings. Failure to comply can cause serious damage resulting in the need to perform major repair work. (00586d)

**NOTE**

Left side footboard fasteners also secure jiffy stand bracket.

1. See Figure 3-166. Remove screw (5) and lockwasher (6).
2. Remove screw (8), lockwasher (9) and flange nut (11).

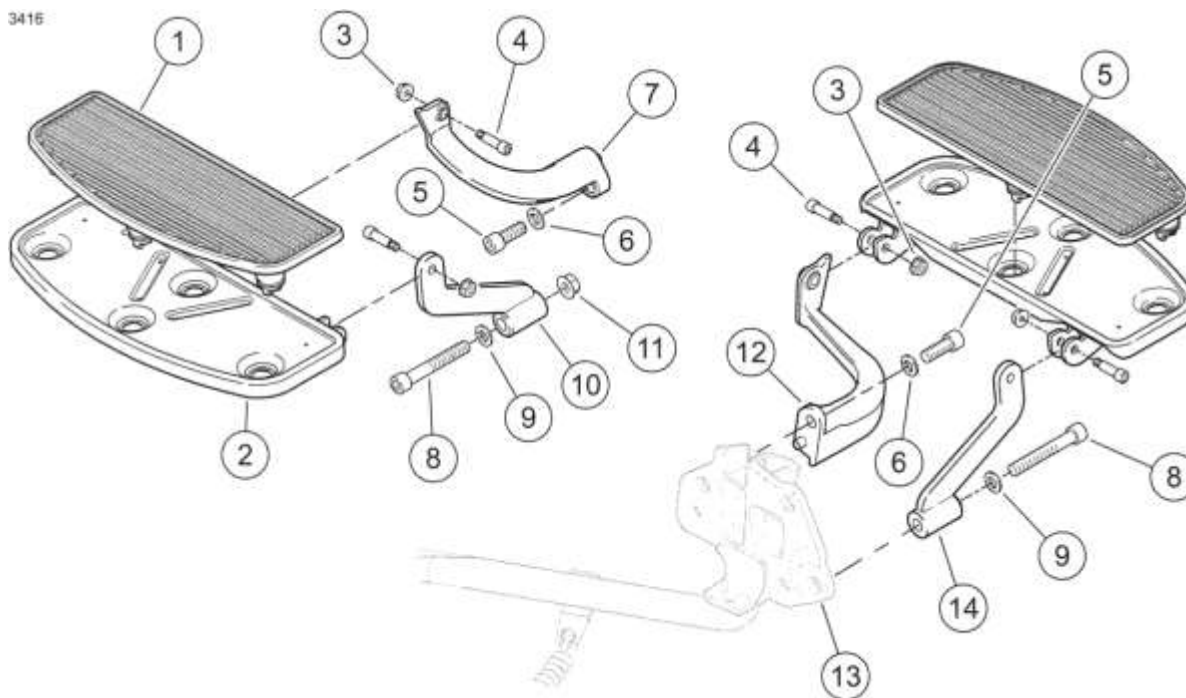
| FASTENER                        | TORQUE VALUE |               |
|---------------------------------|--------------|---------------|
| Footboard bracket screws, rider | 36-42 ft-lbs | 48.8-56.9 N-m |

1. See Figure 3-166. Install footboard and bracket assembly.

**INSTALL**

2. Secure screws (5, 8), lockwashers (6, 9), and flange nut (11). Tighten.

Torque: 36-42 ft-lbs (48.8-56.9 N-m) Footboard bracket screws, rider



- |  |  |
|--|--|
| <ol style="list-style-type: none"> <li>1. Rubber pad</li> <li>2. Footboard</li> <li>3. Pivot screw nut (2)</li> <li>4. Pivot screw (2)</li> <li>5. Socket head screw, short</li> <li>6. Lockwasher</li> <li>7. Right rear bracket</li> </ol> | <ol style="list-style-type: none"> <li>8. Socket head screw, long</li> <li>9. Lockwasher</li> <li>10. Right forward bracket</li> <li>11. Flange nut</li> <li>12. Left rear bracket</li> <li>13. Jiffy stand bracket</li> <li>14. Left forward bracket</li> </ol> |
|--|--|

Figure 3-166. Rider Footboards (Typical) (Quantities shown are for each footboard)

**DISASSEMBLE**

**NOTE**

If only replacing rubber pad, refer to steps 1 and 2, then step 5. See *ASSEMBLE* in this section.

1. Remove rubber pad.
  - a. Remove the four rubber anchors from footboard.

See Figure 3-166. Remove pivot screw nuts (3) and pivot screws (4) from underside of footboard.

3. Remove footboard from brackets.

# PASSENGER FOOTRESTS

3.44

| FASTENER                         | TORQUE VALUE |             |
|----------------------------------|--------------|-------------|
| Footboard pivot screw nut, rider | 60-80 in-lbs | 6.8-9 N'Iri |

## ASSEMBLE

### NOTE

The bottoms of FLHX/FLTRX footboards are stamped L (left) or R (right) to aid proper installation.

1. See Figure 3-166. Hold footboard into position between brackets.
2. Install pivot screws (4) as shown.

3. Install pivot screw nuts (3) onto pivot screws (4). Tighten  
Torque: 60-80 in-lbs (6.8-9 N-m) *Footboard pivot screw nut, rider*
4. Install new pad (1).
  - a. Moisten the four rubber anchors on bottom of pad (1) with soapy water.
  - b. Position pad (1) on footboard (2).
  - c. Pull rubber anchors through holes on footboard.

## COMPLETE

1. Remove motorcycle from upright. See Secure the Motorcycle for Service (Page 2-3).

## REMOVE

### Passenger Footboard

- See Figure 3-167. Remove screw (2), lockwasher (3), screw (7) and footboard/bracket assembly from frame.

### Passenger Footpeg: Standard

- See Figure 3-168. Remove screw (9), lockwasher (10) and shoulder screw (11) to remove footrest bracket (8) from frame.

### Replace Pad and Adjust Footpeg

- Remove socket screw (1).
- Remove footpeg (3) with pad from footrest mount (6).
- Remove rubber pad (2).

## INSTALL

| FASTENER  | TORQUE VALUE |               |
|---|--------------|---------------|
| Footboard/footpeg lower fastener, passenger: FLHX, FLHXS, FLTRX, FLTRXS, FLHRXS | 48-72 in-lbs | 5.4-8.1 N-m   |
| Footboard/footpeg upper fastener, passenger: FLHX, FLHXS, FLTRX, FLTRXS, FLHRXS | 36-42 ft-lbs | 48.8-56.9 N-m |
| Footpeg pad screw: FLHX, FLHXS, FLTRX, FLTRXS, FLHRXS                           | 15-20 ft-lbs | 20.3-27.1 N-m |
| Lower screw (7)   | 48-72 in-lbs | 5.4-8.1 Nm    |
| Upper screw (2)   | 36-42 ft-lbs | 48.8-56.9 N-m |

| PART NUMBER | CONSUMABLE  |
|-------------|---|
| 99642-97    | LOCTITE 243 MEDIUM STRENGTH THREADLOCKER AND SEALANT (BLUE) |

#### NOTE

Passenger footboards and footrests can be installed to one of three positions. To install footboards in a new position, remove plastic plugs from holes in frame.

### Passenger Footboard

- If reusing screws, apply a drop of loctite to threads of screws.  
Consumable: LOCTITE 243 MEDIUM STRENGTH THREADLOCKER AND SEALANT (BLUE) (99642-97)
- See Figure 3-167. Secure bracket (6) with screw (2), lockwasher (3) and screw (7). Tighten.  
Torque: 36-42 ft-lbs (48.8-56.9 N-m) *Upper screw (2)*  
Torque: 48-72 in-lbs (5.4-8.1 N-m) *Lower screw (7)*

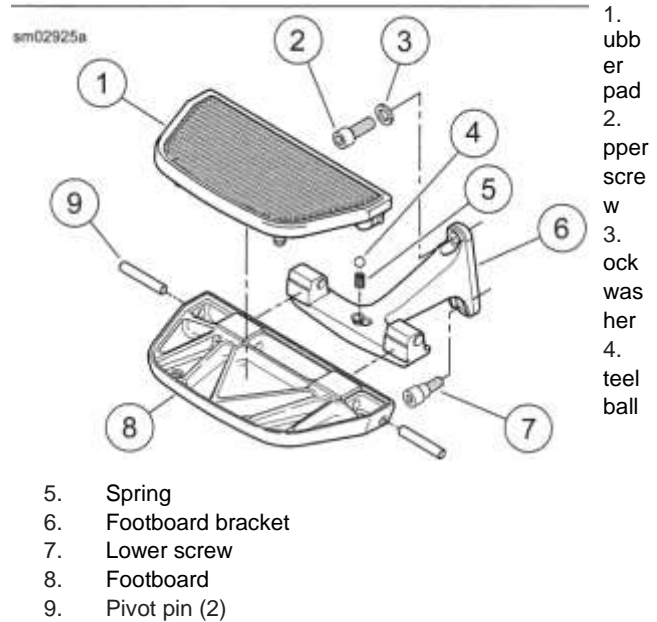


Figure 3-167. Passenger Footboard

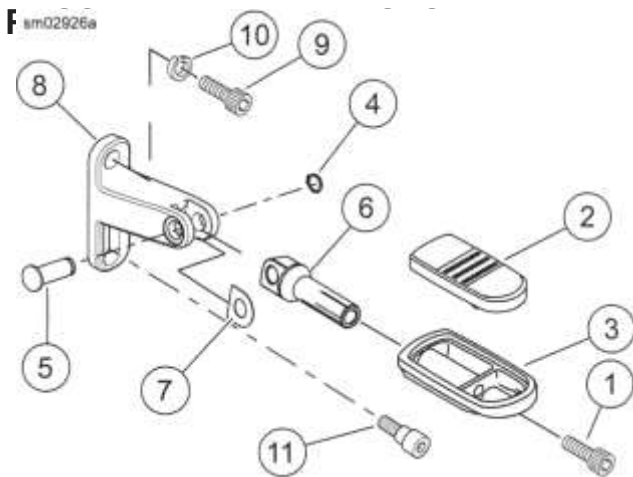
### Passenger Footpeg: Standard

- Locate pivot pin (5).
- See Figure 3-168. Secure bracket (8) with screw (9), lockwasher (10) and shoulder screw (11). Tighten.

Torque: 36-42 ft-lbs (48.8-56.9 Nm) *Footboard/footpeg upper fastener, passenger: FLHX, FLHXS, FLTRX, FLTRXS, FLHRXS*

Torque: 48-72 in-lbs (5.4-8.1 N-m) *Footboard/footpeg lower fastener, passenger: FLHX, FLHXS, FLTRX, FLTRXS, FLHRXS*

1. Rubber pad  
2. Upper screw  
3. Lockwasher  
4. Steel ball  
5. Spring  
6. Footboard bracket  
7. Lower screw  
8. Footboard  
9. Pivot pin (2)



1. Socket screw
2. Rubber pad
3. Footpeg
4. Retaining ring
5. Pivot pin
6. Footpeg mount
7. Wave spring
8. Footpeg bracket
9. Socket screw
10. Lockwasher
11. Shoulder screw

Figure 3-168. Passenger Footpeg: Standard models

### Replace Pad and Adjust Footpeg

1. See Figure 3-168. Install rubber pad (2) onto footpeg (3).
2. Slide assembly onto footpeg mount (6).
3. Apply a drop of loctite to threads of socket screw (1) and install. Tighten.

Torque: 15-20 ft-lbs (20.3-27.1 N-m) *Footpeg pad screw: FLHX,FLHXHXS, FLTRX,FLTRXS,FLHRXS*

### DISASSEMBLE

#### Passenger Footboard

1. See Figure 3-167. Remove rubber pad (1).
2. Tap two pivot pins (9) toward center of footboard (8) and remove.
3. Remove footboard (8) from footboard bracket (6).
4. Remove steel ball (4) and spring (5).

#### Passenger Footpeg: Standard

1. See Figure 3-168. Remove socket screw (1). and rubber pad (2) from footpeg (3).

2. Remove footpeg (3) from footpeg mount (6).
3. Remove retaining ring (4) and pivot pin (5).
4. Remove footpeg mount (6) and wave spring (7).

### ASSEMBLE

| FASTENER   | TORQUE VALUE |               |
|--|--------------|---------------|
| Footpeg pad screw: FLHX,FLHXHXS, FLTRX, FLHRXS, FLHRXS | 15-20 ft-lbs | 20.3-27.1 N-m |

| PART NUMBER | CONSUMABLE  |
|-------------|---|
| 99642-97    | LOCTITE 243 MEDIUM STRENGTH THREADLOCKER AND SEALANT (BLUE) |

### Passenger Footboard

1. See Figure 3-167. Place spring (5) and steel ball (4) into hole in footboard bracket (6).
2. Position footboard (8) on footboard bracket (6) and install pivot pin (9) as shown.
3. Install **new** rubber pad (1).
  - a. Moisten rubber beads on rubber pad (1) with soapy water.
  - b. Position rubber pad (1) on footboard (8).
  - c. Pull rubber beads on inboard corners of rubber pad (1) through holes in footboard (8).

### Passenger Footpeg: Standard

1. See Figure 3-168. Position wave spring (7) with concave side against bracket (8).
2. Install footpeg (3) as shown.
3. Install pivot pin (5). Secure with **new** retaining ring (4).
4. Install footpeg (3) onto footrest mount (6).
5. Install rubber pad (2) into footpeg (3). Rotate footpeg (3) so that rubber pad (2) is topside.
6. Apply a drop of loctite to threads of socket screw (1) and install. Tighten.

Torque: 15-20 ft-lbs (20.3-27.1 N-m) *Footpeg pad screw: FLHXFLHXHXS, FLTRX, FLHRXS, FLHRXS* Consumable: LOCTITE 243 MEDIUM STRENGTH THREADLOCKER AND SEALANT (BLUE) (99642-97)



## PREPARE

1. Set motorcycle upright. See Secure the Motorcycle for Service (Page 2-3).

## REMOVE

### Jiffy Stand Leg

1. See Figure 3-171. Remove jiffy stand leg (7).
  - a. Extend jiffy stand leg (7) to down position.
  - b. Remove hex bolt (3), flat washer (2) and leg stop (4).
  - c. Hold jiffy stand leg (7) forward beyond normal position.
  - d. Remove end of spring (8) from jiffy stand leg (7).
  - e. Remove jiffy stand leg (7) from bracket (1).
  - f. Remove other end of spring (8) from frame weldment.
2. Inspect parts for wear or damage. Replace if necessary.

### Jiffy Stand Bracket

1. Remove left foot control and support brackets. See RIDER FOOTRESTS (Page 3-142).
2. See Figure 3-171. Remove jiffy stand leg (7). See Remove Jiffy Stand Leg in this section.
3. Remove jiffy stand bracket (1).
  - a. Remove two fasteners (5) and lockwashers (6).

## INSTALL

### Jiffy Stand Leg

NOTE

| FASTENER                       | TORQUE VALUE |               |
|--------------------------------|--------------|---------------|
| Jiffy stand bracket fasteners  | 36-42 ft-lbs | 48.8-57 N-m   |
| Jiffy stand leg stop hex screw | 15-20 ft-lbs | 20.3-27.1 N-m |

| PART NUMBER | CONSUMABLE           |
|-------------|----------------------|
| 98960-97    | ANTI-SEIZE LUBRICANT |

See Figure 3-170. Verify that end of spring enters hole from front of leg weldment. If end of spring enters hole from rear of weldment, spring coil will rub on leg when extended.

1. Apply lubricant to area of leg that rotates with bracket.  
Consumable: ANTI-SEIZE LUBRICANT (98960-97)

2. Install spring.
  - a. Insert one end of spring into hole in frame weldment.
  - b. Insert leg up through bracket.
  - c. Hold leg forward beyond normal down position.
  - d. Insert other end of spring into hole on leg weldment.

### A WARNING

**If leg stop is incorrectly installed, excessive wear can allow vehicle to fall when rested on jiffy stand, which could result in death or serious injury. (00479b)**

3. See Figure 3-169. Install leg stop (1).
  - a. Hold leg normal forward (down) position and install leg stop (1) with stamped side down.
  - b. Verify that longer side of leg stop (1) faces rear.
4. Install flat washer and hex screw (2). Tighten.  
Torque: 15-20 ft-lbs (20.3-27.1 N-m) *Jiffy stand leg stop hex screw*

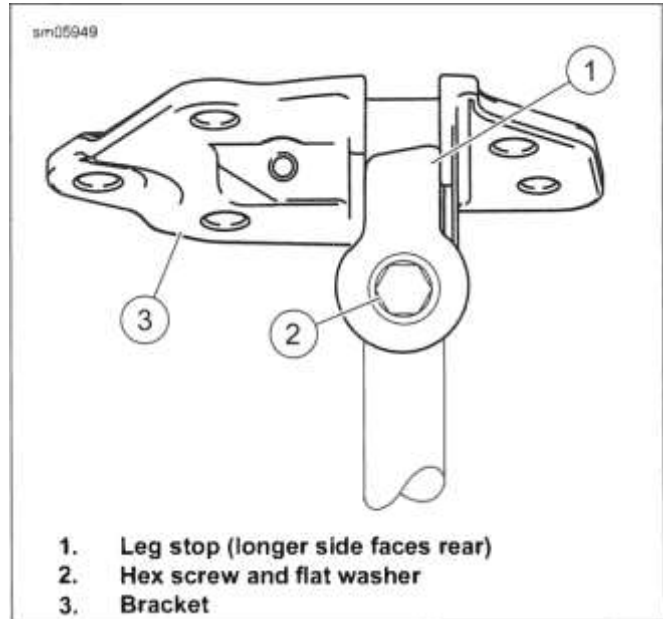
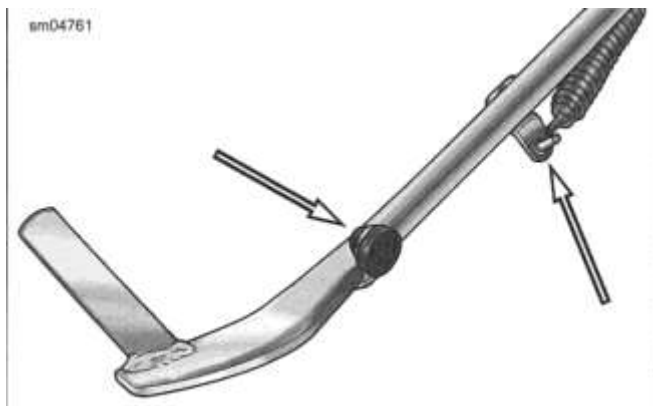


Figure 3-169. Leg Stop Orientation in Full Forward (Down) Position



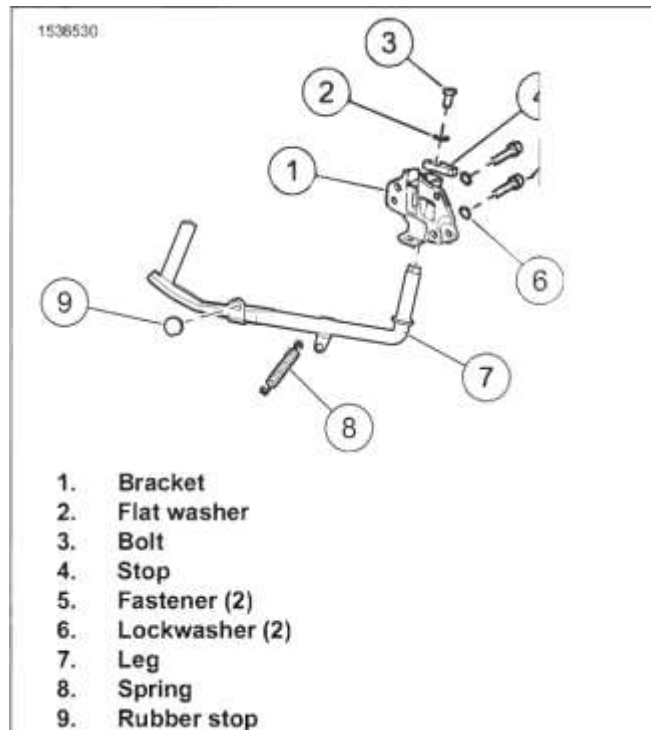
**Figure 3-170. Rubber Stop and Spring Orientation Jiffy**

**Stand Bracket**

1. See Figure 3-171. Install two fasteners (5) and lockwashers (6) to secure front bracket (1) to frame weldment.
2. Temporarily install left foot control rear fastener to align rear of jiffy stand bracket (1) but do not tighten.
3. Secure front fasteners (5). Tighten.

Torque: 36-42 ft-lbs (48.8-57 N-m) *Jiffy stand bracket fasteners*

4. Install left foot control and passenger footrest. See RIDER FOOTRESTS (Page 3-142).
5. Install jiffy stand leg. See Install Jiffy Stand Leg in this section.



**Figure 3-171. Jiffy Stand Assembly**

**COMPLETE**

1. Verify that jiffy stand swings freely to fully extended and retracted positions.
2. Remove motorcycle from upright. See Secure the Motorcycle for Service (Page 2-3).

**NOTE**

See Figure 3-170. Verify that rubber stop is installed in hole of jiffy stand weldment to prevent damage to painted finish.

**REMOVE****Solo Seat (Spring mount)****Remove Seat**

1. See Figure 3-172. Remove seat.
  - a. Remove acorn nuts (4) and washers (3).
  - b. Remove acorn nut (6).
  - c. Remove pivot bolt (5). Remove seat.
2. **If necessary:** Remove seat fairing.
  - a. Remove flange nuts (2) and washers (1).
  - b. Remove seat fairing.

**Disassemble Seat**

1. See Figure 3-173. Remove seat bracket.
  - a. Remove seat nuts (6).
  - b. Remove screw (3) and washer (4).
2. Remove bumper nuts (5), seat rail (8) and bumpers (7).

**Seat Spring****Remove Seat Spring****A WARNING**

**Disconnect negative (-) battery cable first. If positive (+) cable should contact ground with negative (■) cable connected, the resulting sparks can cause a battery explosion, which could result in death or serious injury. (00049a)**

1. Remove seat and seat fairing. See Solo Seat (Spring mount) in this section.
2. Remove battery. See INSPECT BATTERY (Page 2-49).
3. See Figure 3-174. Remove two screws (4) under frame weldment. Remove seat spring (1) from motorcycle.

**Disassemble Seat Spring**

1. **NOTE**  
*Only the upper studs are serviceable. All other components are available only as part of the spring assembly.*

See Figure 3-172. Remove studs (7).

**Seat Mounting Bracket**

1. See Figure 3-174. Remove two fasteners (2) to release seat bracket mount from frame backbone.

**Solo Seat (Frame mount)**

1. See Figure 3-176. Remove seat.
  - a. Remove seat nuts (1).

**Two-Up One-Piece Seat**

1. Open either saddlebag.
2. See Figure 3-177. Remove seat strap screw (1).
3. Open Tour-Pak if equipped.

4.

**NOTE**

- *Access to seat screw requires compression of the rear of seat cushion. Use care to not damage fabric during removal or installation.*
- *If Tour-Pak is located in its forward-most position, the seat screw is difficult to access. Loosen Tour-Pak and slide fully rearward. See TOUR-PAK (Page 3-155).*
- **APC models:** *Remove four Tour-Pak mounting screws. Move Tour-Pak to access seat screw.*

Remove seat screw (3) to release seat.

- a. Raise rear of seat.
  - b. See Figure 3-178 and Figure 3-179. Push seat rearward to free slot from tongue.
5. Remove seat.

**Seat Retention Nut**

1. See See Figure 3-180.. Remove seat retention nut (2).
  - a. Remove retention washer (4).
  - b. Remove retention nut (2).

**Seat Bumper****NOTE**

*FLHX, FLHXS and FLTRX, FLTRXS, FLHRXS models utilize a seat bumper to minimize seat movement.*

1. See See Figure 3-181.. Remove seat bumper (2). a. Remove fastener (3).

**INSTALL**

| PART NUMBER  | TOOL NAME      |
|--------------|----------------|
| HD-94820-75A | SPANNER WRENCH |

| FASTENER                        | TORQUE VALUE |               |
|---------------------------------|--------------|---------------|
| Seat bracket assembly acorn nut | 48-84 in-lbs | 5.4-9.5 N-m   |
| Seat bracket mount screws       | 15-20 ft-lbs | 20.3-27.1 N-m |

| FASTENER  | TORQUE VALUE  |               |
|---|---------------|---------------|
| Seat bracket-to-bumper nuts                                 | 2, ^; z15^    | 300-370 N-m   |
| Seat bumper fastener: FLHX, FLHXS and FLTRX, FLTRXS, FLHRXS | 32-36 ft-lbs  | 43.4-48.8 N-m |
| Seat fairing flange nuts                                    | 60-96 in-lbs  | 6.8-10.8 N-m  |
| Seat mounting screw   | 48-72 in-lbs  | 5.4-8.1 N-m   |
| Seat spring lower screws                                    | 36-60 in-lbs  | 4.1-6.8 N-m   |
| Seat strap screw  | 48-72 in-lbs  | 5.4-8.1 N-m   |
| Seat suspension acorn nuts                                  | 60-96 in-lbs  | 6.8-10.8 N-m  |
| Seat-to-bracket flange nuts                                 | 850-1,274 in- | 96-144 N-m    |
| Seat-to-bracket hex screw                                   | 60-120 in-lbs | 6.8-13.6 N-m  |

| PART NUMBER | CONSUMABLE   |
|-------------|--|
| 94759-99    | LOCTITE 262 HIGH STRENGTH THREADLOCKER AND SEALANT (RED) |

### Solo Seat (Spring mount)

1. See Figure 3-172. If removed, install seat fairing, washers (1) and flange nuts (2). Tighten.  
Torque: 60-96 in-lbs (6.8-10.8 N-m) *Seat fairing flange nuts*
2. Place seat and bracket assembly on motorcycle and install front pivot bolt (5) and acorn nut (6). Tighten.  
Torque: 48-84 in-lbs (5.4-9.5 N-m) *Seat bracket assembly acorn nut*
3. Rotate top spring plate so upper studs (7) are offset to the rear.
4. Align bracket with studs and install washers (4) and acorn nuts (3). Tighten.  
Torque: 60-96 in-lbs (6.8-10.8 N-m) *Seat suspension acorn nuts*

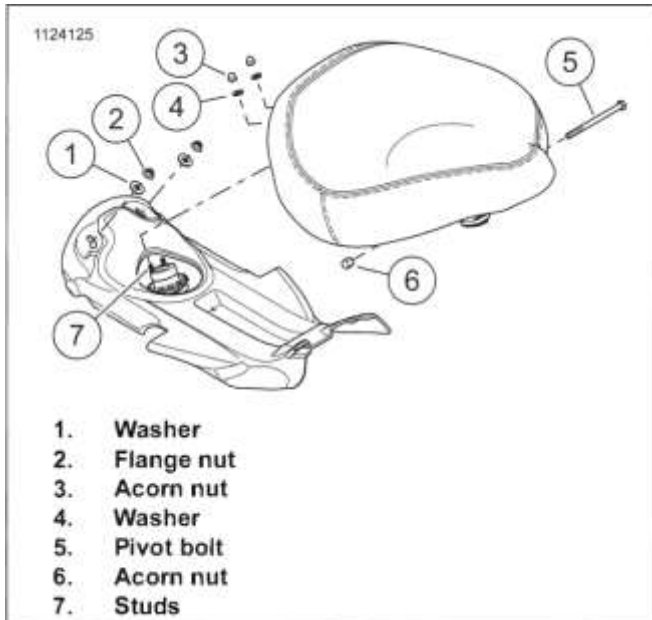


Figure 3-172. Seat Attachment

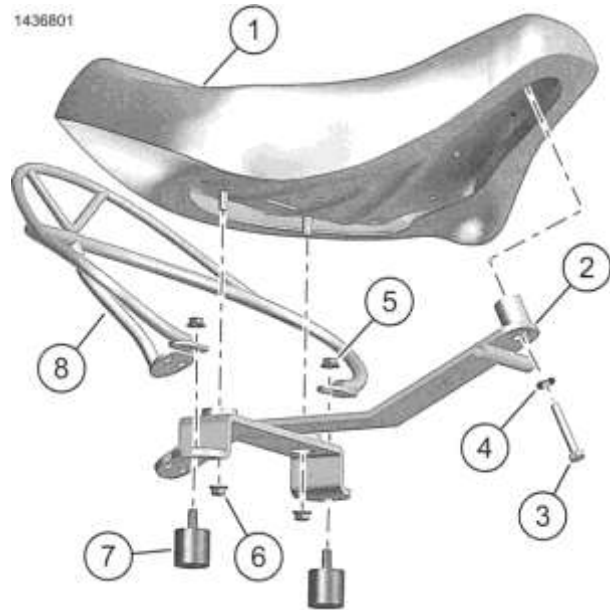
### Assemble Seat

1. See Figure 3-173. Install seat bracket.
  - a. Install washer (4) on screw (3).
  - b. Install screw finger tight.

- c. Install seat nuts (6). Tighten.  
Torque: 850-1,274 in-lbs (96-144 N-m) *Seat-to-bracket flange nuts*
- d. Tighten screw (3).  
Torque: 60-120 in-lbs (6.8-13.6 N-m) *Seat-to-bracket hex screw*

### 2. Install seat rail (8).

- a. Install bumpers (7).
  - b. Install seat rail (8).
  - c. Install bumper nuts (5). Tighten.  
Torque: 2,655-3,275 in-lbs (300-370 N-m) *Seat bracket-to-bumper nuts*
1. Seat
  2. Seat bracket
  3. Screw
  4. Washer
  5. Bumper nut (2)
  6. Seat nut (2)
  7. Bumper (2)



8. Seat rail

Figure 3-173. Seat Assembly

### Seat Spring

#### A WARNING

Connect positive (+) battery cable first. If positive (+) cable should contact ground with negative (-) cable connected, the resulting sparks can cause a battery explosion, which could result in death or serious injury. (00068a)

1. See Figure 3-174. Place seat spring on frame weldment and align holes.

2. Install two new screws (4). Tighten.

Torque: 36-60 in-lbs (4.1-6.8 N-m) *Seat spring lower screws*

3. Install battery. See INSPECT BATTERY (Page 2-49).

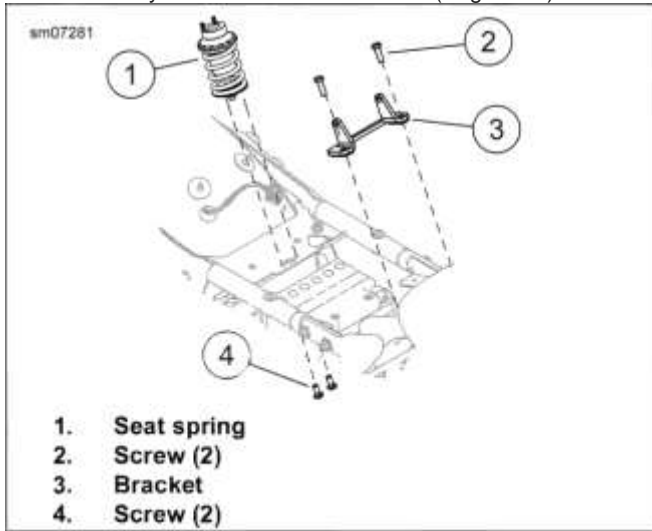


Figure 3-174. Seat Spring Assembly

### Assemble Seat Spring

1. If using original studs, apply a drop of threadlocker to studs.

Consumable: LOCTITE 262 HIGH STRENGTH THREADLOCKER AND SEALANT (RED) (94759-99)

2. Install upper studs until bottomed in threaded hole.
3. Allow threadlocker to cure before installing spring assembly.
4. If removed, push upper rubber cap into place.

### Adjust Seat Suspension

#### NOTE

Use a drift and hammer or SPANNER WRENCH (PART NUMBER: HD-94820-75A) to loosen and tighten nuts.

1. NOTE
  - Range of adjustment (3) must be kept within 0.7-1.1 in (17.7-27.7 mm) as measured from the top of the shock absorber to the top of the jamnut. Settings outside this range may result in failure of the suspension components.
  - Factory preset is approximately 0.9 in (21.7 mm) which is suitable for a 200.0 lb (90.7 kg) person.

See Figure 3-175. Loosen jamnut (1).

2. Rotate adjustment nut (2) clockwise to compensate for a heavier rider. Each full rotation equals the specified amount of rider weight.

12.6 lb (5.7 kg)

3. Tighten jamnut.

#### NOTE

Seat bracket bumpers provide cushioning under certain riding conditions. If seat system is modified ride comfort may be affected.

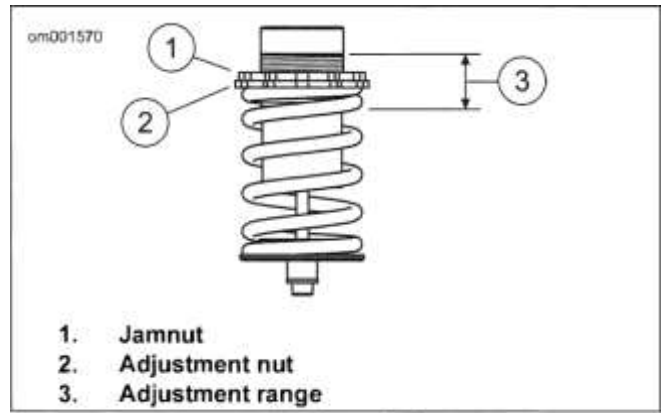


Figure 3-175. Seat Adjustment

### Seat Mounting Bracket

1. See Figure 3-175. Install seat bracket mount using two screws (2). Tighten.

Torque: 15-20 ft-lbs (20.3-27.1 N-m) *Seat bracket mount screws*

### Solo Seat (Frame mount)

1. See Figure 3-176. Install seat.
  - a. Push front of seat downward and forward until slot engages tongue.

- b. Install seat nuts (1).

2. Pull up on seat to verify that it is secure.

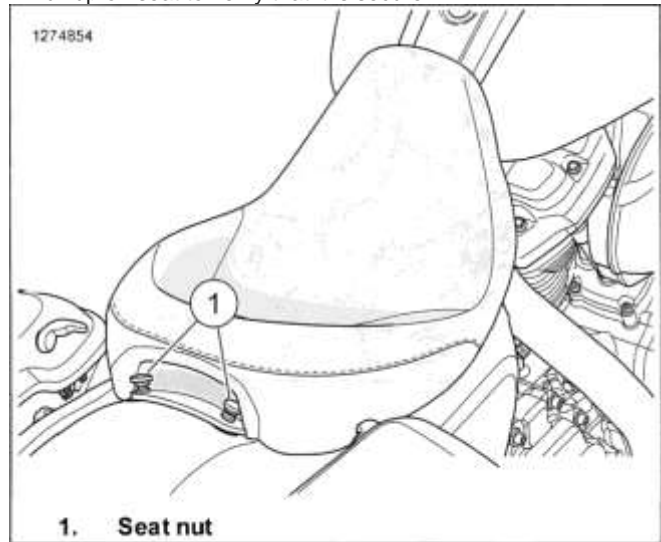


Figure 3-176. Solo Seat

### Two-Up One-Piece Seat

#### NOTE

To protect finish of Tour-Pak if equipped, cover rear seat mounting bracket with palm of hand.

#### NOTE

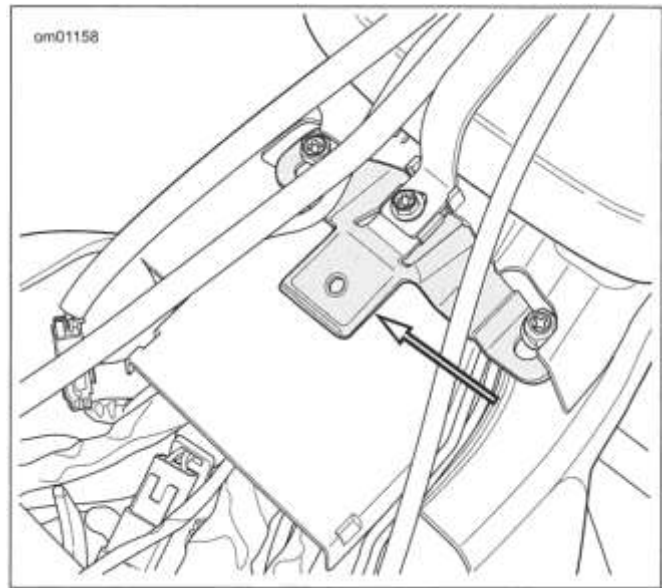
- Access to seat screw requires compression of the rear of seat cushion. Use care not to damage fabric during removal or installation.
- If Tour-Pak was relocated to access seat screw, secure it in the original position. See TOUR-PAK (Page 3-155).

1. See Figure 3-178 and Figure 3-179. Place seat in position.

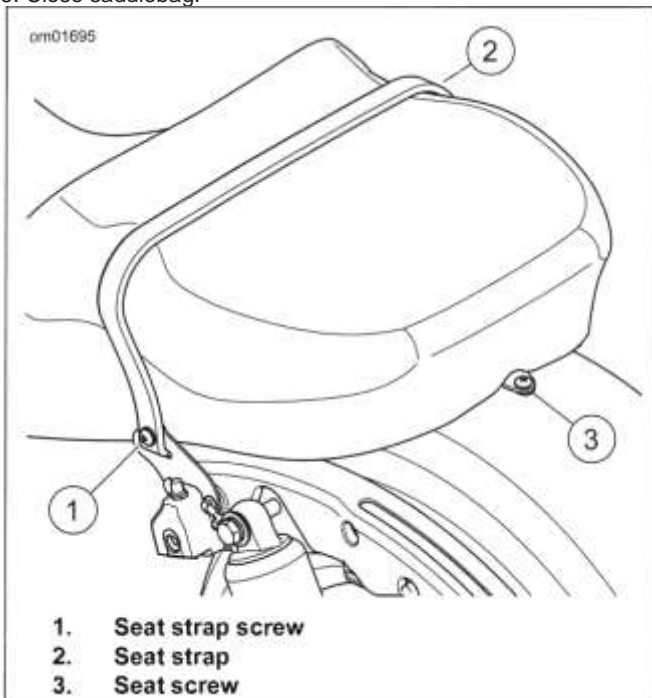
2. Hold rear of seat approximately 76.2 mm (3 in) above fender.
  - a. Push front of seat downward and forward until slot engages tongue.
3. Secure seat to fender with seat screw. Tighten.
 

Torque: 48-72 in-lbs (5.4-8.1 N-m) *Seat mounting screw*
4. See Figure 3-177. Tuck end of seat strap (2) into slot.
  - a. Secure seat strap screw (1) and washer. Tighten. Torque:
 

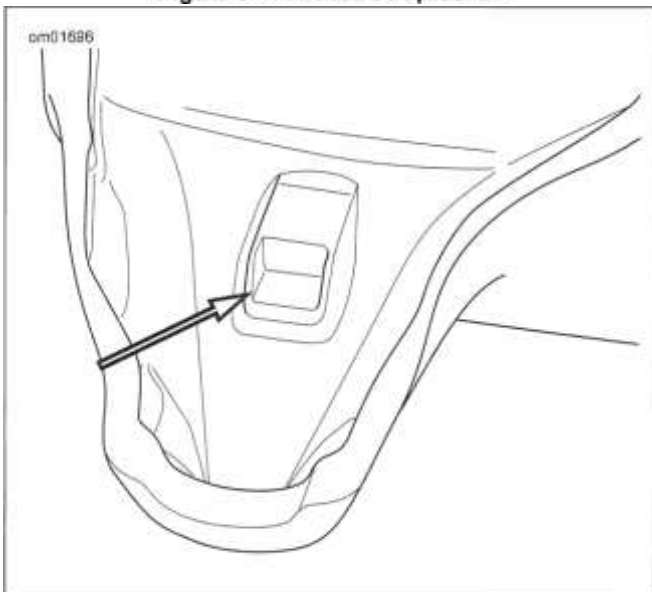
48-72 in-lbs (5.4-8.1 N-m) *Seat strap screw*
5. Pull up on seat to verify that it is secure.
6. Close saddlebag.



**Figure 3-179. Seat Tongue**



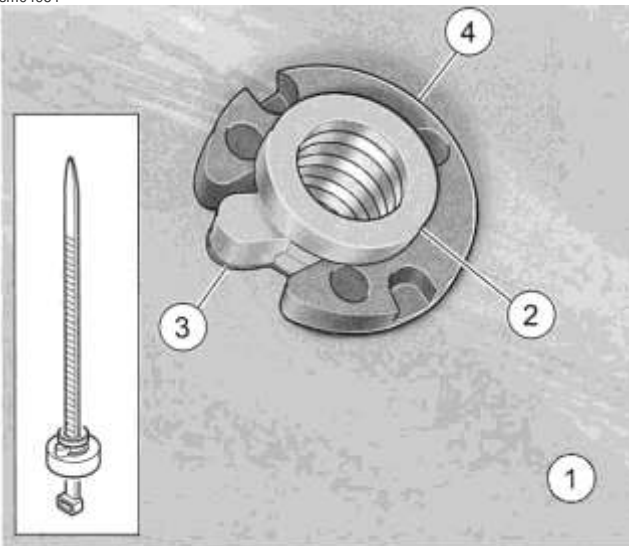
**Figure 3-177. Seat Strap Screw**



**Figure 3-178. Seat Mounting Slot**

### Seat Retention Nut

1. See Figure 3-180. Slide new retention nut (2) onto cable strap.
2. Insert into fender hole and hold with cable strap.
3. Align tab (3) on retention nut and hold nut snug against underside of rear fender. Align and install retention washer (4).
4. Remove cable strap.



1. Rear fender
2. Retention nut
3. Tab
4. Retention washer

Figure 3-180. Install Seat Retention Nut

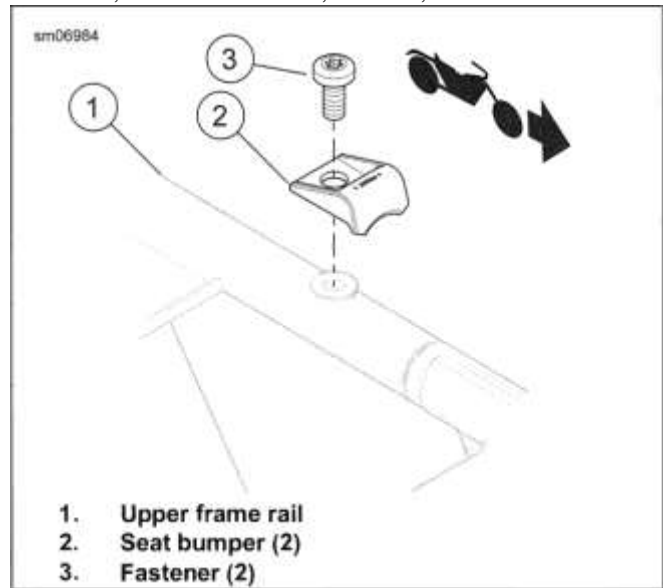
### Seat Bumper

#### NOTE

*FLHX, FLHXS and FLTRX, FLTRXS, FLHRXS models utilize a seat bumper to minimize seat movement.*

1. See Figure 3-181. Install a seat bumper (2) to each upper frame rail (1).
2. Secure with fastener (3). Tighten.

Torque: 32-36 ft-lbs (43.4-48.8 N-m) *Seat bumper fastener: FLHX, FLHXS and FLTRX, FLTRXS, FLHRXS*



1. Upper frame rail
2. Seat bumper (2)
3. Fastener (2)

Figure 3-181. Seat Bumper Installation

# REAR FRAME

3.47

## PREPARE

### NOTICE

When lifting a motorcycle using a jack, be sure jack contacts both lower frame tubes where down tubes and lower frame tubes converge. Never lift by jacking on cross-members, oil pan, mounting brackets, components or housings. Failure to comply can cause serious damage resulting in the need to perform major repair work. (00586d)

1. Remove saddlebags. See SADDLEBAGS (Page 3-161).
2. Remove left side cover. See LEFT SIDE COVER (Page 3-62).
3. Remove main fuse. See POWER DISCONNECT (Page 8-8).
4. Remove right side cover. See RIGHT SIDE COVER (Page 3-63).
5. Raise rear of motorcycle.
6. Remove seat. See SEAT (Page 3-148).
7. Remove top caddy. See TOP CADDY (Page 8-107).
8. Remove battery. See INSPECT BATTERY (Page 2-48).
9. 

*NOTE Record*

*cable strap locations for assembly.*

Cut cable straps securing harnesses to rear frame. Move harnesses aside.
10. Remove Tour-Pak, if equipped. See TOUR-PAK (Page 3-153).
11. Remove luggage rack, Tour-Pak support or spacers as equipped. See TOUR-PAK SUPPORT (Page 3-159).
12. Remove saddlebag supports. See SADDLEBAG SUPPORTS (Page 3-165).
13. Remove rear fender. See REAR FENDER (Page 3-137).
14. Remove shock absorbers. See REAR SHOCK ABSORBERS (Page 3-80).
15. Remove two rear battery tray fasteners. See BATTERY TRAY (Page 8-113).
16. Remove fastener securing left electrical caddy to rear frame.

## REMOVE

1. See Figure 3-178. Remove six fasteners (2) and washers (3) securing rear frame (1).
2. Remove rear frame.

## Thread Repair

### NOTE

- Never re-tap the threaded holes in the rear frame to repair damaged threads. Always use the following procedure to provide repair-.
  - If more than one threaded hole is damaged on a given side, or if a thread repair has previously been done, replace the rear frame. Never repair more than one hole per side.
1. Remove damaged fastener.
  2. Drill out damaged threads. Install appropriate size thread repair insert.
  3. Install **new** fastener with hardened washer. Tighten to specified torque.

## INSTALL

1. See Figure 3-178. Hold rear frame in place. Start two lower fasteners (2) with hardened washers (3). Install four

| FASTENER                          | TORQUE VALUE               |
|-----------------------------------|----------------------------|
| Rear frame to main frame fastener | 40-45 ft-lbs   54.2-61 N-m |

remaining upper fasteners with hardened washers.

2. See Figure 3-179. Tighten rear frame fasteners in sequence shown.  
  
Torque: 40-45 ft-lbs (54.2-61 N-m) *Rear frame to main frame fastener*



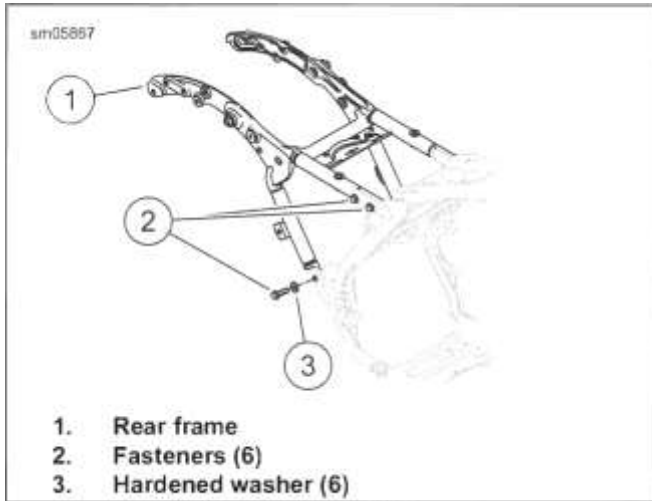
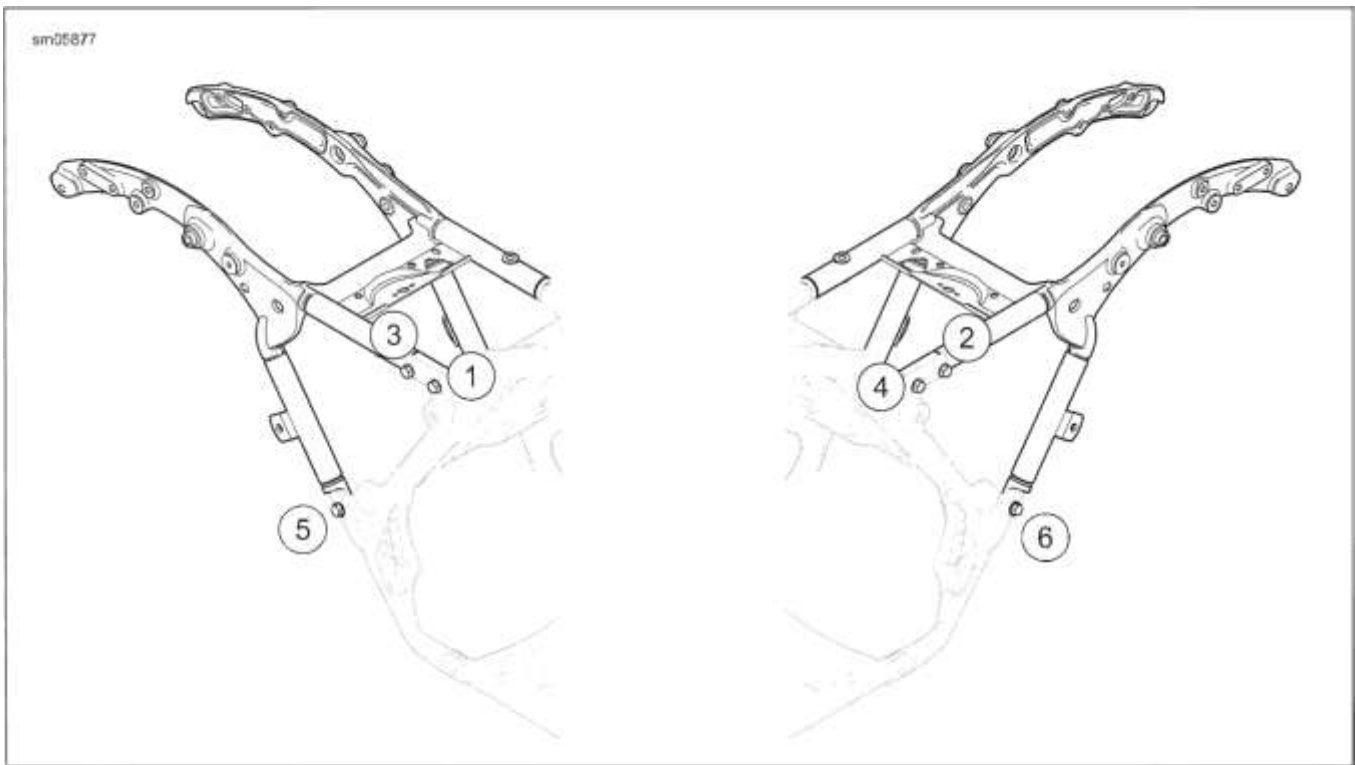


Figure 3-178. Subframe



**Figure 3-179. Rear Frame Torque Sequence**

### **COMPLETE**

1. Secure left side caddy to rear frame. See LEFT SIDE CADDY (Page 8-108).
2. Secure upper battery tray to rear frame. See BATTERY TRAY (Page 8-113).
3. Install shock absorbers. See REAR SHOCK ABSORBERS (Page 3-80).
4. Install rear fender. See REAR FENDER (Page 3-137).
5. Install saddlebag supports. See SADDLEBAG SUPPORTS (Page 3-165).
6. Install luggage rack, Tour-Pak support or spacers as equipped. See TOUR-PAK SUPPORT (Page 3-159).
7. Install Tour-Pak, if equipped. See TOUR-PAK (Page 3-153).
8. Install battery. See INSPECT BATTERY (Page 2-48).
9. Install top caddy. See TOP CADDY (Page 8-107).
10. *NOTE*  
Locate straps as noted during disassembly.  
  
Secure harnesses to rear frame with new cable straps.
11. Install seat. See SEAT (Page 3-148).
12. Install right side cover. See RIGHT SIDE COVER (Page 3-63).
13. Install main fuse. See POWER DISCONNECT (Page 8-8).
14. Install left side cover. See LEFT SIDE COVER (Page 3-62).
15. Install saddlebags. See SADDLEBAGS (Page 3-161 ).
16. Lower motorcycle.

**PREPARE** \_\_\_\_\_

1. Remove main fuse. See POWER DISCONNECT (Page 8-8).

**REMOVE** \_\_\_\_\_

**TOUR-PAK**

*NOTE*

*Slot in Tour-Pak support allow position adjustment. Record position before removal.*

*NOTE*

*APC models offer no adjustment. The adapter plate locates Tour-Pak to meet market regulations.*

1. See Figure 3-180. Separate electrical connectors.
2. Remove four flange nuts securing Tour-Pak to support rack.
3. APC models: See Figure 3-182. Remove four screws and flat washers adapter plate from support rack. Slid forward to release L-hooks.
4. Remove assembly.
5. APC models: Remove four flange nuts to release adapter plate from Tour-Pak.

**TOUR-PAK BACKREST**

**Passenger Backrest**

1. Remove three flange nuts and flat washers.
2. Remove backrest from Tour-Pak.

**Rubber Isolators**

1. remove passenger backrest. See Passenger Backrest in this section.
2. See Figure 3-183. Remove hair pin (1).
3. Remove pin (4) and washers(2).
4. Remove backrest support bracket (5) with rubber isolators (3).
5. Remove rubber isolators (3) from backrest support bracket (5) .

**Passenger Backrest Flap**

1. Remove molded liner from Tour-Pak. See TOUR-PAK SUPPORT (Page 3-159).
2. Remove two acorn nuts and screws with flat washers.

3. Remove backrest flap.

**INSTALL** \_\_\_\_\_

| FASTENER                         | TORQUE VALUE   |               |
|----------------------------------|----------------|---------------|
| Passenger backrest flange nuts.  | 108-132 in-lbs | 12.2-14.9 N-m |
| Passenger backrest flap screws   | 21-24 in-lbs   | 2.4-2.7 N-m   |
| Tour-Pak adapter mounting screws | 60-72 in-lbs   | 6.8-8.1 N-m   |
| Tour-Pak mounting nuts           | 60-72 in-lbs   | 6.8-8.1 N-m   |

**TOURPAK**

*NOTE*

*Make sure connectors do not get trapped between Tour-Pak and mount.*

1. APC models: Attach adapter to Tour-Pak. Secure with four flange nuts (4). Tighten.  
Torque: 60-72 in-lbs (6.8-8.1 N-m) *Tour-Pak mounting nuts*
2. Set Tour-Pak in place.
3. Install four flange nuts (4). Tighten.  
Torque: 60-72 in-lbs (6.8-8.1 N-m) *Tour-Pak mounting nuts*
4. APC models: See Figure 3-181.
  - a. Engage L-hooks (5) in support rack (4).
  - b. Align rear holes with rear slots in support rack (4).
  - c. See Figure 3-182. Loosely install rear washers and screws.
  - d. Align front holes with front slots in support rack.
  - e. Install front washers and screws. Tighten.  
Torque: 60-72 in-lbs (6.8-8.1 N-m) *Tour-Pak adapter mounting screws*
5. See Figure 3-180. Mate Tour-Pak electrical connectors. Secure with anchors.

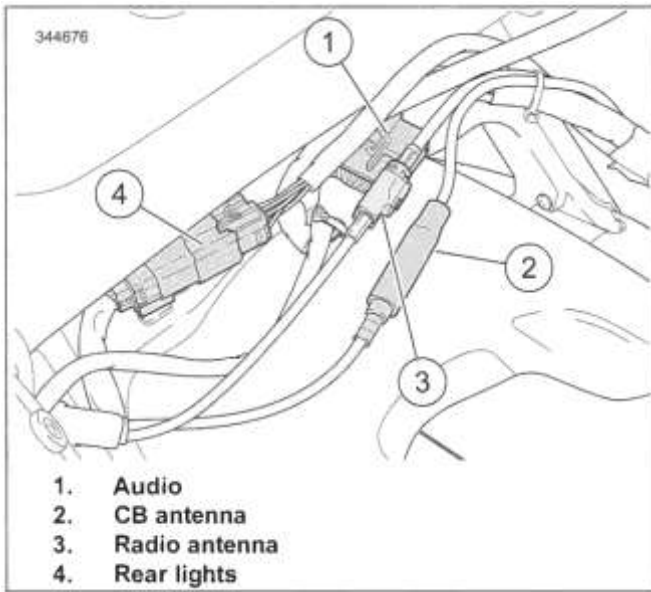


Figure 3-180. Tour-Pak Connectors

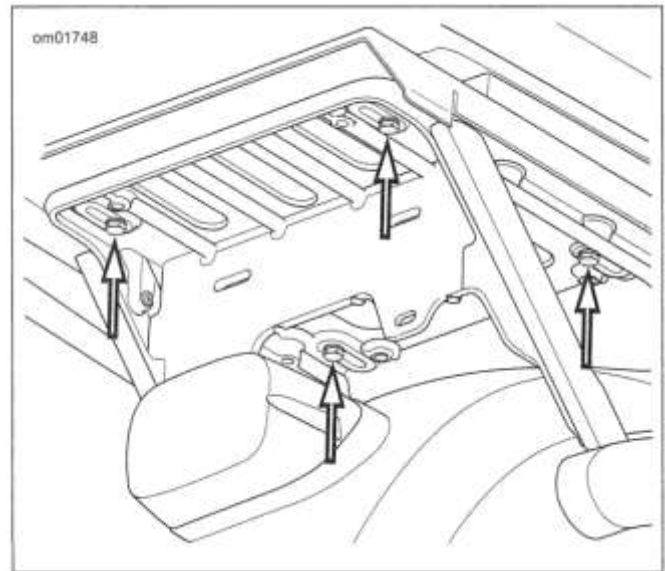


Figure 3-182. Tour-Pak Bracket Screws (APC Models) flange nuts.

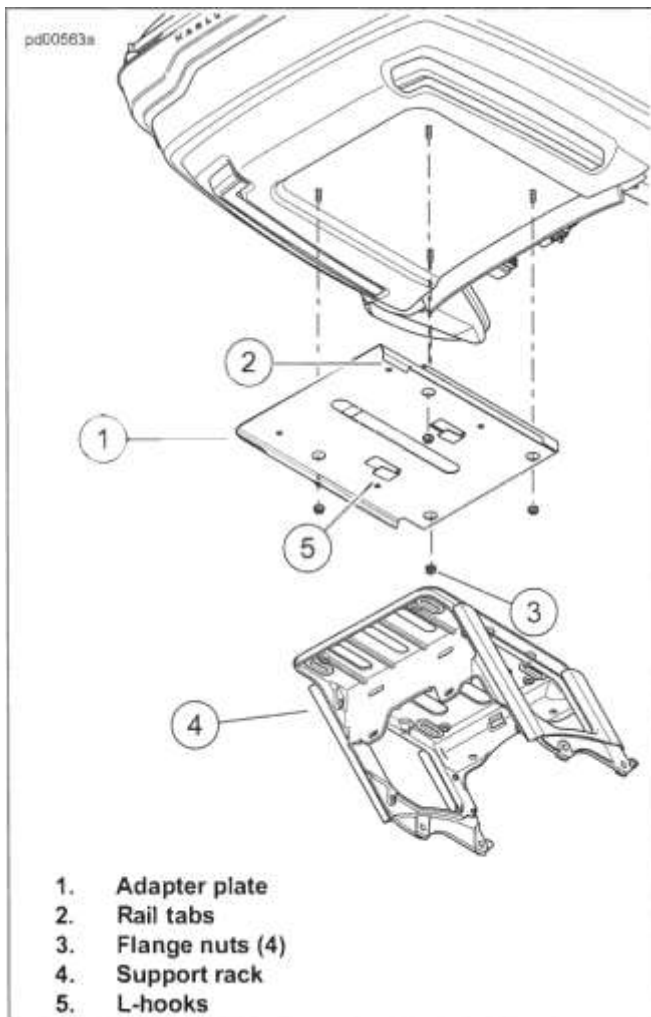


Figure 3-181. Tour-Pak Adapter Plate

### Rubber Isolators

**NOTE**

Left and right backrest support brackets are identified with "L" and "R" respectively. Center backrest support bracket has no identification.

1. See Figure 3-183. Place rubber isolators (3) in backrest support bracket (5).
2. Locate backrest support bracket assembly in backrest. Install washers (2) and pin (4).
3. Secure assembly with hair pin (1).

**NOTE**

Washers (2) have a shoulder that fits into bores of backrest mounting area.

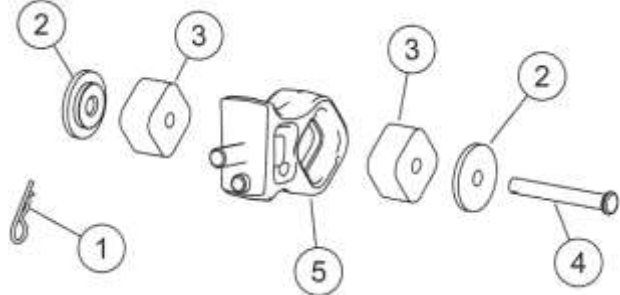
4. Install passenger backrest. See Passenger backrest in this section.

## TOUR-PAK BACKREST

### Passenger Backrest

1. Hold backrest on Tour-Pak lid.
2. Secure with flange nuts and flat washers. Tighten.  
Torque: 108-132 in-lbs (12.2-14.9 N-m) *Passenger backrest*

sm07458



1. Hair pin
2. Washer
3. Rubber isolator
4. Pin
5. Backrest support bracket

Figure 3-183. Mount and Isolator (typical)

### Passenger Backrest Flap

1. Secure backrest flap with two screws (with flat washers) and acorn nuts. Tighten.  
Torque: 21-24 in-lbs (2.4-2.7 N-m) *Passenger backrest flap screws*
2. Tuck flap between seat and Tour-Pak to hide wires.
3. Install molded liner in Tour-Pak. See TOUR-PAK SUPPORT (Page 3-159).

### DISASSEMBLE AND ASSEMBLE

| PART NUMBER | TOOL NAME         |
|-------------|-------------------|
| HD-25070    | ROBINAIR HEAT GUN |

| FASTENER                         | TORQUE VALUE |             |
|----------------------------------|--------------|-------------|
| Tour-Pak catch screws            | 25-35 in-lbs | 2.8-3.9 N-m |
| Tour-Pak hinge screw             | 25-35 in-lbs | 2.8-3.9 N-m |
| Tour-Pak latch handle screws     | 25-35 in-lbs | 2.8-3.9 N-m |
| Tour-Pak lockset screws          | 25-35 in-lbs | 2.8-3.9 N-m |
| Tour-Pak luggage rack fastener   | 40-48 in-lbs | 4.5-5.4 N-m |
| Tour-Pak mounting nuts           | 60-72 in-lbs | 6.8-8.1 N-m |
| Tour-Pak side marker lamp screws | 20-25 in-lbs | 2.3-2.8 N-m |
| Tour-Pak tether anchor screws    | 16-22 in-lbs | 1.8-2.5 N-m |
| Tour-Pak tether reel screws      | 16-22 in-lbs | 1.8-2.5 N-m |

| PART NUMBER | CONSUMABLE                          |
|-------------|-------------------------------------|
|             | 3M GENERAL PURPOSE ADHESIVE REMOVER |

### TOUR-PAK LINER

#### Disassemble

**NOTE**

For service of wrap-around lamp, marker lamps/trim strips and harness, see TOUR-PAK LIGHTING (Page 8-62).

1. Support lid partly open.

2. Remove screws securing tether anchor.
3. Remove liner.
4. Loosely install tether anchor.

#### Assemble

1. Remove tether anchor.
2. Install liner.
3. Secure tether anchor with screws. Tighten.  
Torque: 16-22 in-lbs (1.8-2.5 N-m) *Tour-Pak tether anchor screws*

### TOUR-PAK SEAL Disassemble

**NOTE**

Use ROB/NAIR HEAT GUN (PART NUMBER: HD-25070) to improve seal removal.

1. Remove old seal and all residual adhesive using the following adhesive remover or equivalent.  
Consumable: 3M GENERAL PURPOSE ADHESIVE REMOVER()

#### Inspect

1. Inspect for accumulation of dirt, grime or debris. Clean with warm soapy water, if necessary.
2. Inspect parts for wear or damage. Replace if brittle, cracked, torn or shredded.
3. Verify that seal is adhered securely. Replace if seal is not securely adhered at any point.

#### Assemble

**NOTE**

Do not touch cleaned area after cleaning.

1. Thoroughly clean seal mounting surface around cover using a clean cloth and isopropyl alcohol.
2. Peel back a few inches of backing material. Beginning at front middle, adhere end of seal. Work only a few inches at a time.

**NOTE**

To prevent possibility of water intrusion, be careful seal does not bunch or kink at corners.

3. Continue around opening until seal returns to point of beginning.

**NOTE**

Do not cut seal long. Doing so may cause seal to bunch allowing a path of water intrusion.

4. Cut seal squarely so end mate tightly together. A gap of up to 1.6 mm (0.062 in) is allowed.
5. After entire seal is initially installed, go back and verify seal is securely adhered by pressing firmly around entire seal.

## HINGES

### Disassemble

*NOTE*

Carefully compress seal when removing and installing screws nearest the edge of the lid.

1. Remove eight screws securing hinge to Tour-Pak and lid.
2. Remove hinge.

### Assemble

*NOTE*

- Hinges are identified by having letter "F"ront or "R"ear cast into them.
- Two screws securing nearest edge of lid are washerless and shorter than remaining six. Install shorter screws first.

1. Hold hinge in place.
2. Install screws securing hinge to Tour-Pak and lid. Tighten.  
Torque: 25-35 in-lbs (2.8-3.9 N-m) *Tour-Pak hinge screw*

## TOUR-PAK LOCK Disassemble

1. See Figure 3-184. Open latch handle (1) completely.
2. Remove two screws (2).
3. Remove Lock.

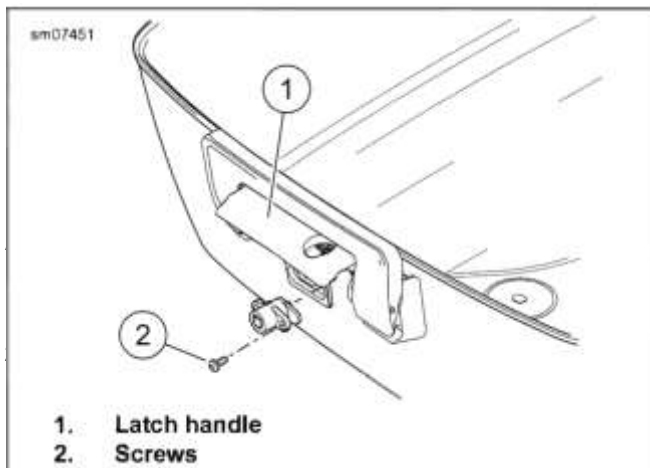


Figure 3-184. Latch Handle and Lockset Assembly

## LATCH HANDLE AND CATCH Disassemble

1. Remove lockset. See Tour-Pak Lock in this section.
2. See Figure 3-185. Remove screws (4).
3. Remove latch handle assembly (3) with lock.

4. Remove screws (2).
5. Remove catch (1).

## Assemble

1. See Figure 3-185. Secure catch (1) to lid with screws (2). Tighten.  
Torque: 25-35 in-lbs (2.8-3.9 N-m) *Tour-Pak catch screws*
2. Hold latch handle assembly (3) in place and secure with screws (4). Tighten.  
Torque: 25-35 in-lbs (2.8-3.9 N-m) *Tour-Pak latch handle screws*

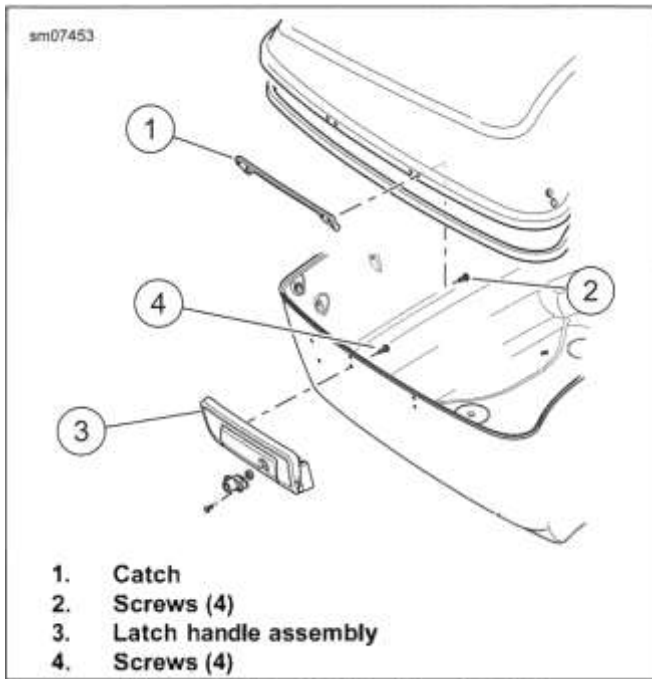


Figure 3-185. Latch Handle and Catch

## TETHER

### Disassemble

#### NOTE

Support Tour-Pak lid to keep it from opening beyond normal travel.

1. Remove passenger backrest. See Tour-Pak Backrest in this section.
2. See Figure 3-186. Remove tether anchor screws (2).
3. Remove tether reel screws (1) securing tether reel.

### Assemble

1. See Figure 3-186. Secure tether reel with tether reel screws (1). Tighten.

Torque: 16-22 in-lbs (1.8-2.5 N-m) *Tour-Pak tether reel screws*

#### NOTE

Do not allow tether ribbon to twist during installation.

2. Secure tether anchor with tether anchor screws (2). Tighten.  
Torque: 16-22 in-lbs (1.8-2.5 N-m) *Tour-Pak tether anchor screws*
3. Install passenger backrest. See Tour-Pak Backrest in this section.

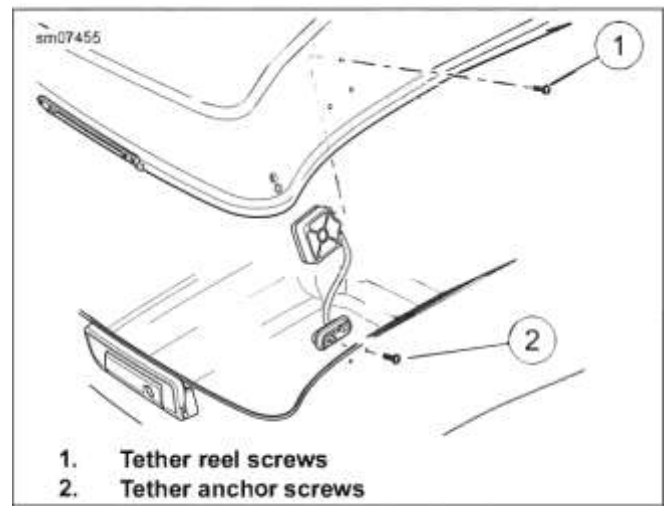


Figure 3-186. Tether Mechanism Screws

## LUGGAGE RACK

### Disassemble

1. See Figure 3-187. Hold luggage rack while removing screws (4), nylon washers (2) and flat washers (3).
2. Remove luggage rack.

### Assemble

1. Hold luggage rack in place with mounting pads (1) between luggage rack and lid.
2. Secure with one nylon washer (2), one flat washer (3) and screw (4) on each stud.
3. Tighten in a crosswise pattern.

Torque: 40-48 in-lbs (4.5-5.4 N-m) *Tour-Pak luggage rack fastener*

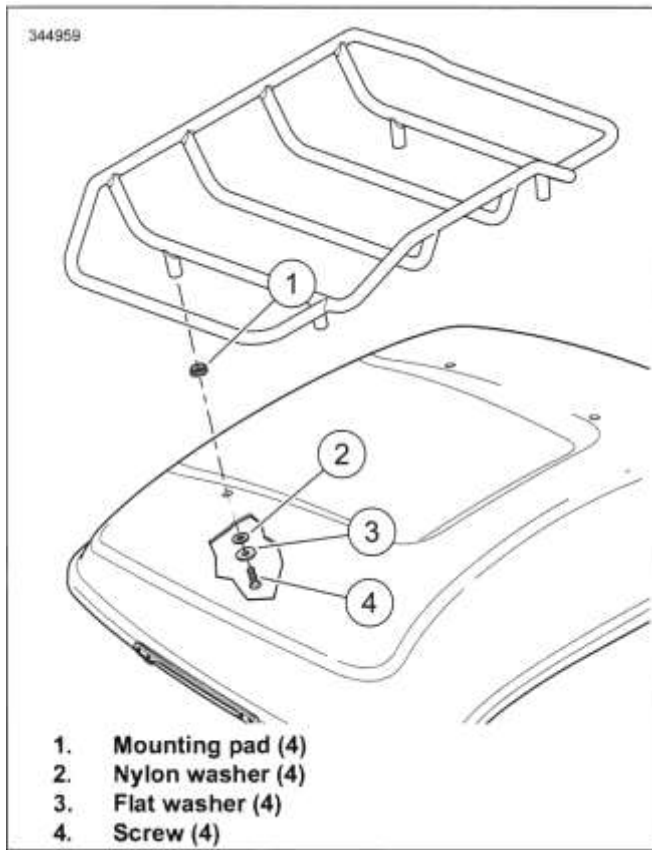


Figure 3-187. Luggage Rack

1. Mounting pad (4)
2. Nylon washer (4)
3. Flat washer (4)
4. Screw (4)

### GROUND PLATE Disassemble

1. Remove Tour-Pak liner. See Tour-Pak Liner in this section.
2. Disconnect ground wire connectors.

#### NOTE

See Figure 3-188. Screws (2) secure both ground plate (1) and marker lamps/trim strips.

3. Remove screws (2).

#### NOTE

Slots in Tour-Pak support allow position adjustment. Record position before removal.

4. Hold Tour-Pak from tipping and remove four flange nuts (3).
5. Remove ground plate (1).
6. Install a temporary screw and nut to prevent Tour-Pak from tipping until assembly.

### Assemble

1. Hold Tour-Pak from tipping while removing temporary screw and nut.

#### NOTE

Screws (2) secure both ground plate and marker lamps/trim strips.

2. See Figure 3-188. Install ground plate (1).
3. Install four flange nuts (3). Tighten.  
Torque: 60-72 in-lbs (6.8-8.1 N-m) *Tour-Pak mounting nuts*
4. While holding lamps in position, install screws (2). Tighten.  
Torque: 20-25 in-lbs (2.3-2.8 N-m) *Tour-Pak side marker lamp screws*
5. Mate two ground connectors to ground plate (1).
6. Install Tour-Pak liner. See Tour-Pak Liner in this section.

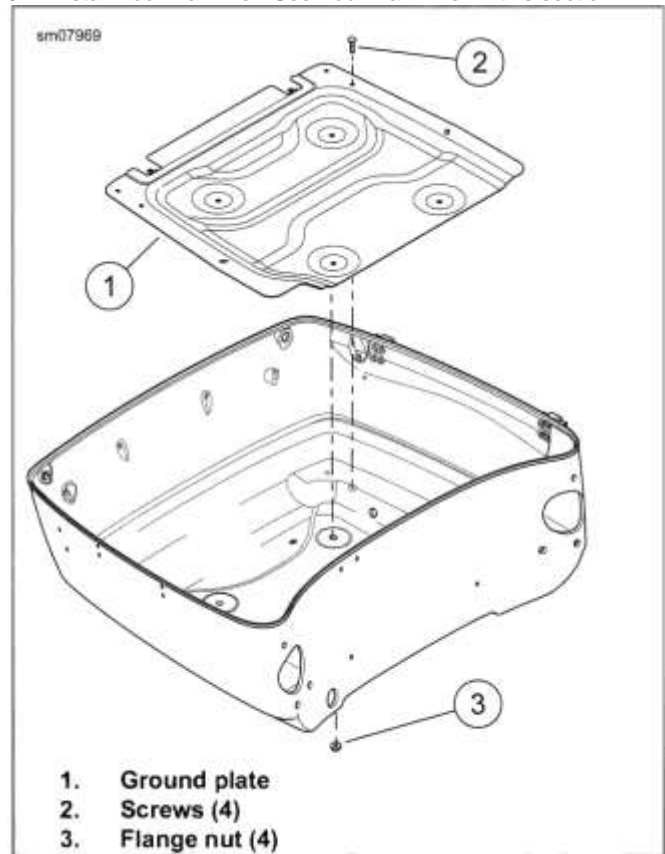


Figure 3-188. Ground Plate

1. Ground plate
2. Screws (4)
3. Flange nut (4)

### COMPLETE

1. Install main fuse. See POWER DISCONNECT (Page 8-8).



**PREPARE**

1. Remove main fuse. See POWER DISCONNECT (Page 8-8).

**REMOVE**

*NOTE*

*Models without Tour-Pak have inserts in place where Tour-Pak supports mounts.*

1. See Figure 3-189. Remove harness connectors from anchors on support.
2. Remove two screws (3) from each side.
3. Remove Tour-Pak support.

**INSTALL**

| FASTENER                | TORQUE VALUE |               |
|-------------------------|--------------|---------------|
| Tour-Pak support screws | 15-20 ft-lbs | 20.3-27.1 N-m |

1. See Figure 3-189. Install Tour-pak support (1).

2. Install screws (3). Tighten.  
Torque: 15-20 ft-lbs (20.3-27.1 N-m) *Tour-Pak support screws*
3. Secure harness connectors to anchors on support (4).
4. Install Tour-Pak if removed.

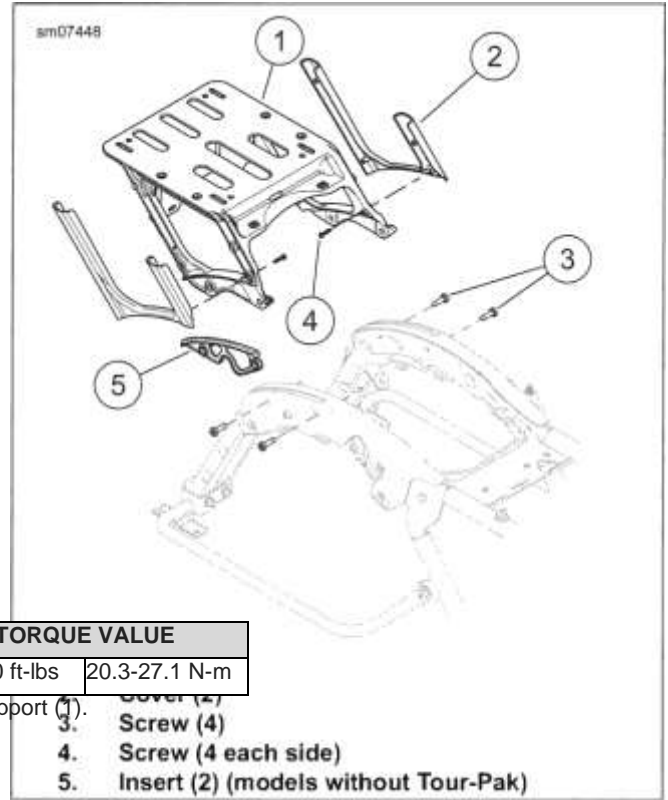


Figure 3-189. Tour-Pak Support

**DISASSEMBLE**

1. See Figure 3-190. Remove four screws (4).
2. Remove cover (2).

| FASTENER                      | TORQUE VALUE |           |
|-------------------------------|--------------|-----------|
| Tour-Pak support cover screws | 8-18 in-lbs  | 0.9-2 N-m |

1. Install cover. Secure with screws (4). Tighten.  
Torque: 8-18 in-lbs (0.9-2 N-m) *Tour-Pak support cover screws*

**COMPLETE**

1. Install main fuse. See POWER DISCONNECT (Page 8-8).

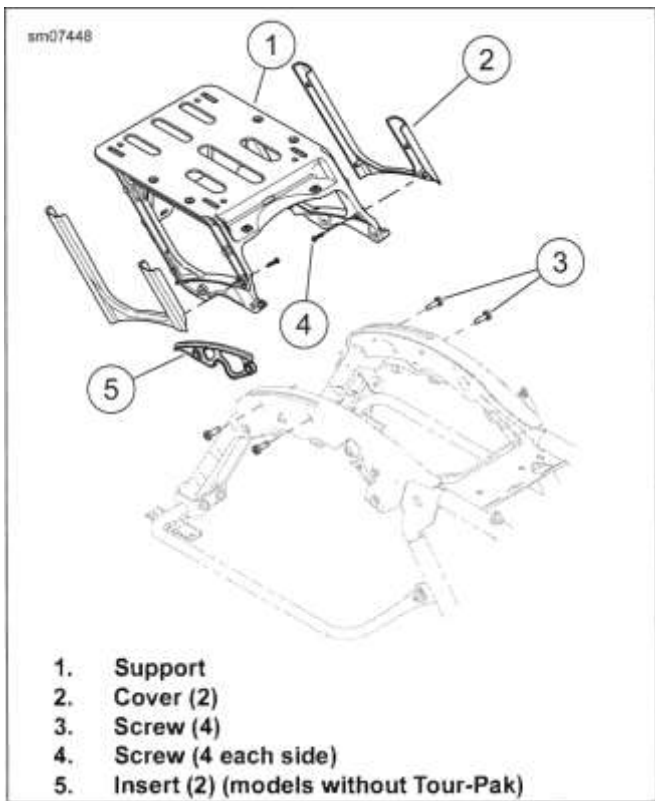


Figure 3-190. Tour-Pak Support

**REMOVE**

1. Open saddlebag lid.
2. See Figure 3-191. Turn mounting screw levers counterclockwise to remove.
3. Remove saddlebag.

**INSTALL****NOTE**

Replace grommets if torn or deteriorated.

1. See Figure 3-191. Place saddlebag in position on saddlebag rail (2).

2. **NOTE**

The rear mounting screw lever will interfere with the saddlebag cover unless positioned with lever pointed downward.

Install mounting screws through grommets into support bracket.

- a. Tighten mounting screws until lever is pointed downward as shown.
3. Check that saddlebag is securely fastened.
  - a. Verify that saddlebag bottom isolators properly engage the lower support tube.
  - b. Pull on saddlebag to confirm that it is securely fastened.
4. Close saddlebag lid.

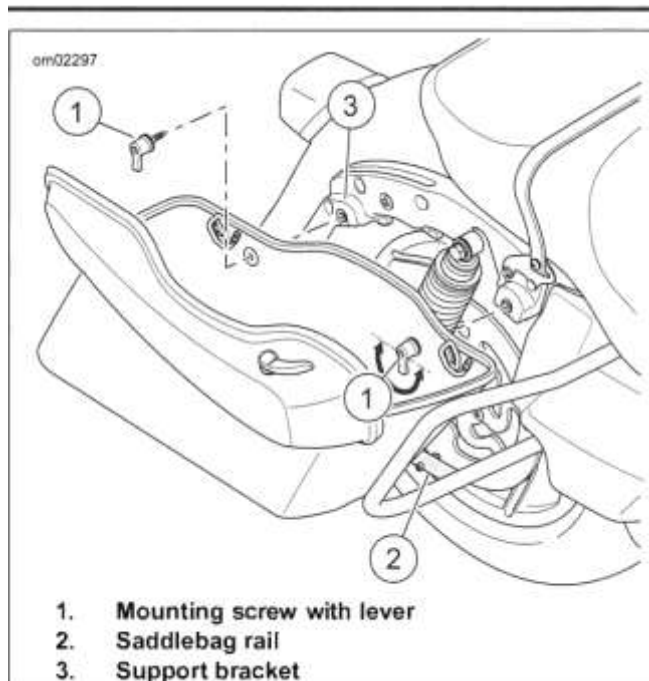


Figure 3-191. Saddlebag Removal/Installation

**DISASSEMBLE****NOTE**

The saddlebag can remain installed when servicing most of the following components.

**Lock**

1. See Figure 3-192. Hold face plate (1) while removing screws (2). Remove face plate.
2. Remove nut (3). Remove lock lever (5).
3. Remove two screws (4).
4. Remove lock (6).

**Strikes**

1. See Figure 3-193. Remove four screws (5).
2. Remove strike (6).

**Cover**

1. If removed from vehicle, place saddlebag on protected surface with cover open.
2. Carefully peel seal away from hinge area.

3. **NOTE**

Latch assembly remains secured to hinge.

See Figure 3-194. Remove screw (6) and latch lever (3). Do not lose grommet (2).

4. Optional: To ease access to screws (8), remove screws securing tether to latch assembly.
5. Hold face plate (9) while removing three hinge screws (7).
6. Remove four screws (5). Remove cover from latch assembly.

### Cover Seal

1. Remove old seal.
2. Remove all residual adhesive using 3M GENERAL PURPOSE ADHESIVE REMOVER.

### Hinge

1. Remove the saddlebag.
2. Place on a protected surface with cover open.
3. See Figure 3-193. Remove screws (4) securing tether to saddlebag.
4. Remove two remaining screws (2). Separate cover with latch assembly from saddlebag.
5. Remove nut and lever from lock.
6. Carefully peel seal away from hinge area.
7. See Figure 3-194. Remove three screws (7).
8. Remove two screws (8). Remove hinge.

### Latch Assembly

**NOTE**

The latch assembly has no serviceable parts. Replace assembly upon failure.

1. Remove screws securing tether to latch assembly.
2. Remove nut and lever from lock.
3. **NOTE**  
Hinge can remain secured to saddlebag.

Remove cover. See procedure elsewhere in this section.

4. See Figure 3-194. Remove two screws (7) securing hinge to latch assembly. Remove latch assembly.

### Skid Plate, FLHRXS

1. Mark skid plate location using masking tape.
2. Carefully pry off old skid plate.
3. Remove all adhesive residue.

## ASSEMBLE

| FASTENER                                 | TORQUE VALUE |             |
|--|--------------|-------------|
| Saddlebag face plate/hinge screw         | 40-45 in-lbs | 4.5-5.1 N-m |
| Saddlebag face plate/hinge screws        | 40-45 in-lbs | 4.5-5.1 N-m |
| Saddlebag hinge to latch assembly screws | 30-35 in-lbs | 3.4-3.9 N-m |
| Saddlebag hinge to saddlebag screws      | 40-45 in-lbs | 4.5-5.1 N-m |
| Saddlebag latch assembly screws          | 40-45 in-lbs | 4.5-5.1 N-m |
| Saddlebag latch handle screw             | 40-45 in-lbs | 4.5-5.1 N-m |
| Saddlebag lock lever nut                 | 25-35 in-lbs | 2.8-3.9 N-m |
| Saddlebag lock screw                     | 20-30 in-lbs | 2.3-3.4 N-m |
| Saddlebag strike screw                   | 15-20 in-lbs | 1.7-2.3 N-m |
| Saddlebag tether screws                  | 40-45 in-lbs | 4.5-5.1 N-m |

### Lock

1. See Figure 3-192. Install lock assembly with tab nearest to cover.
2. Secure with two screws (4). Tighten.  
Torque: 20-30 in-lbs (2.3-3.4 N-m) *Saddlebag lock screw*
3. Install lock lever. Secure with nut (3). Tighten.  
Torque: 25-35 in-lbs (2.8-3.9 N-m) *Saddlebag lock lever nut*
4. Secure face plate with screws (2). Tighten.  
Torque: 40-45 in-lbs (4.5-5.1 N-m) *Saddlebag face plate/hinge screw*

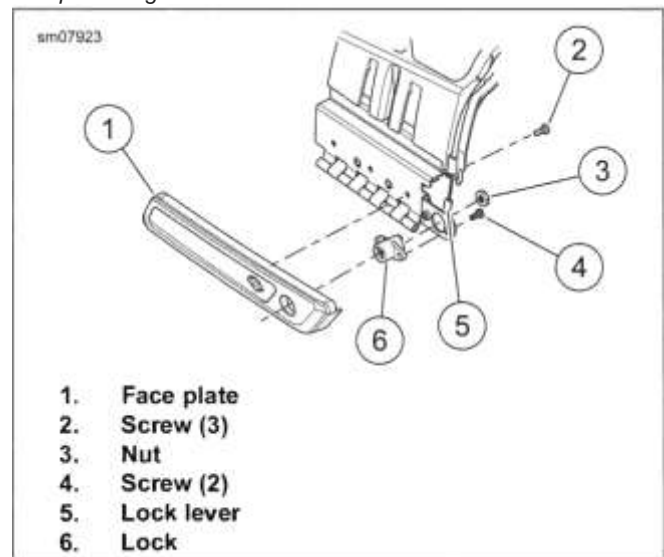


Figure 3-192. Saddlebag Lock

### Strikes

1. See Figure 3-193. Install strike. Secure with screws (5). Tighten.  
Torque: 15-20 in-lbs (1.7-2.3 N-m) *Saddlebag strike screw*

## Cover

### NOTE

If installing a new cover, install new seal included. See procedure later in this section.

1. See Figure 3-194. Inspect condition of foam seal (4).
3. Install seal onto hinge. If adhesive does not hold, use
  2. While holding cover in place, loosely install four screws (5).
3. Hold face plate (9) in place and install screws (7). Tighten.  
Torque: 40-45 in-lbs (4.5-5.1 N-m) *Saddlebag face plate/hinge screws*
4. Tighten screws (5).  
Torque: 40-45 in-lbs (4.5-5.1 N-m) *Saddlebag latch assembly screws*
5. Install foam seal onto hinge. If adhesive does not hold, use automotive weatherstrip adhesive following manufacturer's directions.
6. Inspect condition of grommet (2) on handle shaft.
7. Install latch lever (3). Secure with screw (6). Tighten.  
Torque: 40-45 in-lbs (4.5-5.1 N-m) *Saddlebag latch handle screw*

## Cover Seal

1. **NOTE**  
*Do not touch the cleaned area with fingers after cleaning.*

Thoroughly clean seal mounting area with isopropyl alcohol. Allow to dry completely.

2. Peel back a few inches of backing and place end of seal at midpoint of hinge area. Work only a few inches at a time.
3. Install seal without stretching.
4. Cut squarely to length so no gap exists.
5. After entire seal is initially installed, go back around entire seal and press firmly in place to verify it is securely adhered.

## Hinge

### NOTE

If tether is removed completely, install with top of logo facing saddlebag.

1. See Figure 3-194. Align hinge. Secure with screws (8). Tighten.  
Torque: 30-35 in-lbs (3.4-3.9 N-m) *Saddlebag hinge to latch assembly screws*
2. Hold face plate (9) in place and install screws (7). Tighten.  
Torque: 40-45 in-lbs (4.5-5.1 N-m) *Saddlebag face plate/hinge screws*
5. Install screws (2). Tighten.

automotive weatherstrip adhesive following manufacturers directions.

4. **NOTE**  
*See Figure 3-193. Screws (2, 4) are easily cross-threaded. Use extreme care when installing.*

Align hinge with saddlebag and loosely install screws (4) without the tether to maintain alignment.

Torque: 40-45 in-lbs (4.5-5.1 N-m) *Saddlebag hinge to saddlebag screws*

6. Remove screws (4), install tether and secure. Tighten.  
Torque: 40-45 in-lbs (4.5-5.1 N-m) *Saddlebag tether screws*
7. Install lock lever. Secure with nut. Tighten.  
Torque: 25-35 in-lbs (2.8-3.9 N-m) *Saddlebag lock lever nut*

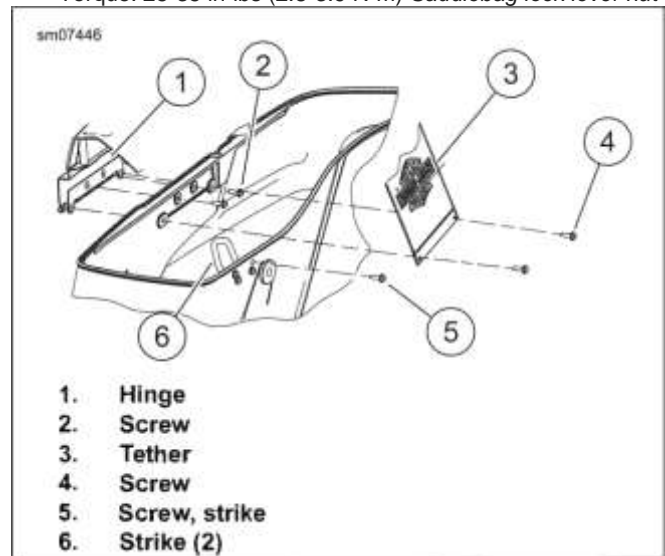


Figure 3-193. Saddlebag Hinge

## Latch Assembly

1. See Figure 3-194. Secure hinge to latch assembly with two screws (7).

2. **NOTE**  
*Verify foam seal (4) is in place on latch assembly*

Install cover and latch lever (3). See procedure elsewhere in this section.

3. Secure tether to latch assembly. Tighten.  
Torque: 40-45 in-lbs (4.5-5.1 N-m) *Saddlebag tether screws*
4. Install lock lever. Secure with nut. Tighten.  
Torque: 25-35 in-lbs (2.8-3.9 N-m) *Saddlebag lock lever nut*

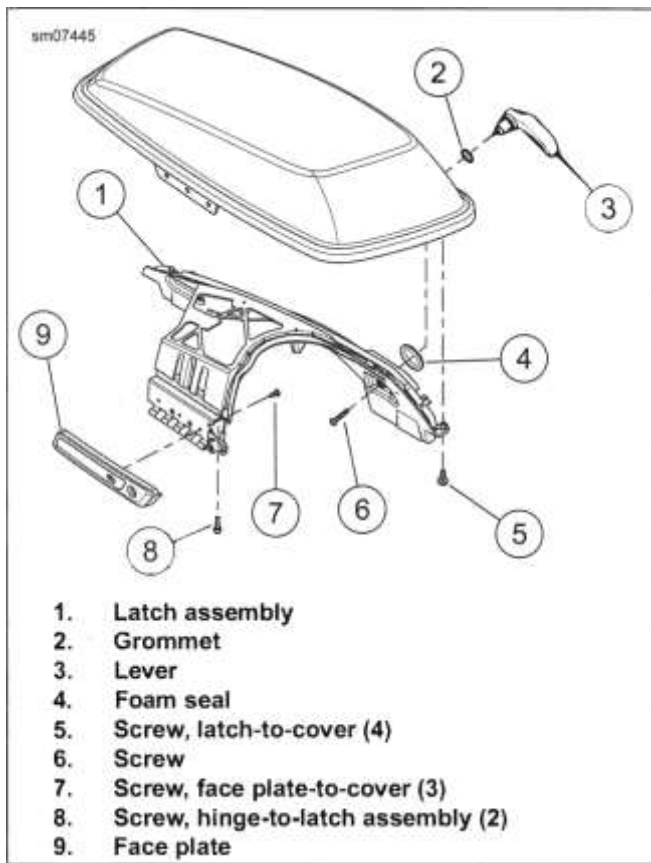


Figure 3-194. Saddlebag Latch Assembly

b. Keep dry for 24 hours.

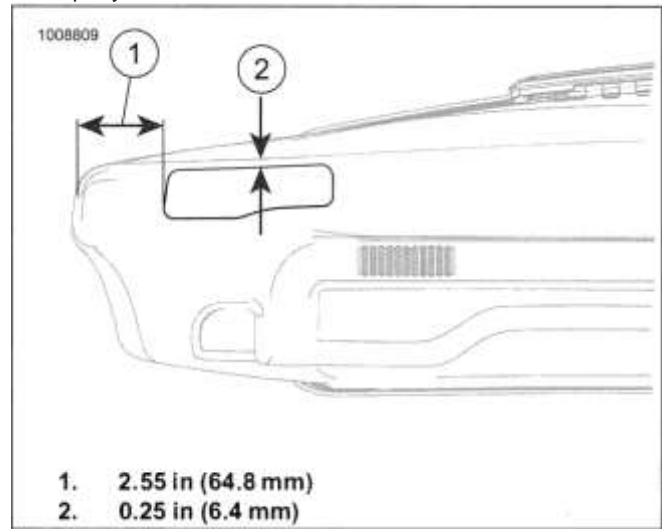


Figure 3-195.

## Skid Plate

1. *NOTE*  
 If skid plate location could not be marked earlier, locate as shown in Figure 3-195.

Clean mounting area with isopropyl alcohol. Allow to dry completely.

2. Install new skid plate.
- a. Press into place for 15 seconds.

## PREPARE

1. Remove left and right saddlebags. See SADDLEBAGS (Page 3-163).
2. Remove left side cover. See LEFT (Page 3-62).
3. Remove main fuse. See POWER DISCONNECT (Page 8-8).
4. Remove seat. See SEAT (Page 3-148).
5. Remove fasteners and lockwashers securing muffler to saddlebag support.

## REMOVE

### Support

1. See Figure 3-200. Remove screw (4) and flange nut.
2. Remove screws (5, 6).
3. Remove screws (1, 8) to release support casting (10).
4. Remove saddlebag support assembly with support casting.
5. Disassemble as needed.

### Guard Rails

1. See Figure 3-202. Remove screws (9), lockwashers (8) and clamp (7).
2. Remove nuts (5, 6).
3. Remove screw (3) and lockwasher (4).
4. Remove screw (2).
5. Remove guard rail (1).

## INSTALL

| FASTENER  | TORQUE VALUE  |               |
|---|---------------|---------------|
| Front Clamp Screw   | 65 in-lbs     | 7.3 N-m       |
| Rear Inboard Screw  | 15-20 ft-lbs  | 20.3-27.1 N-m |
| Rear Outboard Screw                                       | 30-37 ft-lbs  | 40.7-50.2 N-m |
| Saddlebag guard to frame screw, lower                     | 32-36 ft-lbs  | 43.4-48.8 N-m |
| Saddlebag guard to frame screw, upper                     | 32-36 ft-lbs  | 43.4-48.8 N-m |
| Saddlebag support casting to frame screw                  | 15-20 ft-lbs  | 20.3-27.1 N-m |
| Saddlebag support tube screw                              | 70-100 in-lbs | 7.9-11.3 N-m  |
| Saddlebag support tube to support casting fastener, large | 30-37 ft-lbs  | 40.7-50.2 N-m |

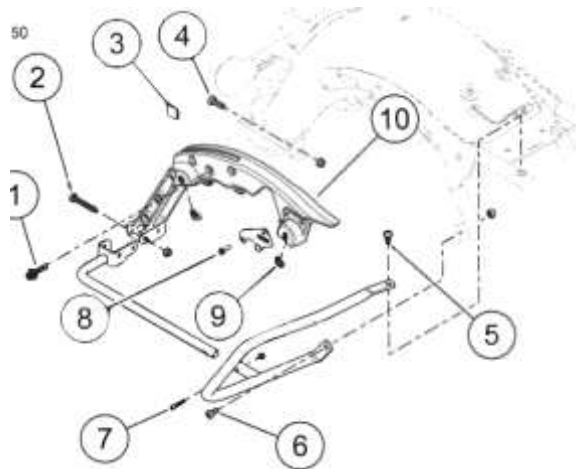
| FASTENER  | TORQUE VALUE   |               |
|---|----------------|---------------|
| Saddlebag support tube to support casting fastener, small | 15-20 ft-lbs   | 20.3-27.1 N-m |
| Seat strap bracket screw                                  | 120-144 in-lbs | 13.6-16.3 N-m |

### NOTE

- For fastener torque specifications Refer to Table 3-10.
  - See Figure 3-200. Support tube screw (2) is installed from rear to front on all models except FLHX, FLHXS, FLTRX, FLTRXS.
1. Assemble saddlebag support along with support casting. For tightening specifications Refer to Table 3-10.
  2. See Figure 3-201. Verify that rubber cushion is in place and not damaged.
  3. See Figure 3-200. If removed, install saddlebag mounting clips (9).
  4. Install saddlebag support assembly with support casting.

Table 3-10. Saddlebag Support Fastener Torque Specifications

| ITEM | TORQUE                         |
|------|--------------------------------|
| 1    | 15-20 ft-lbs (20.3-27.1 N-m)   |
| 2    | 30-37 ft-lbs (40.7-50.2 N-m)   |
| 4    | 15-20 ft-lbs (20.3-27.1 N-m)   |
| 5    | 32-36 ft-lbs (43.4-48.8 N-m)   |
| 6    | 32-36 ft-lbs (43.4-48.8 N-m)   |
| 7    | 70-100 in-lbs (7.9-11.3 N-m)   |
| 8    | 120-144 in-lbs (13.6-16.3 N-m) |



1. Screw, support casting
2. Screw, support tube-to-support casting
3. Cushion
4. Screw, support casting/support-to-fender
5. Screw, saddlebag guard, upper
6. Screw, saddlebag guard, lower
7. Screw, saddlebag support tube
8. Screw, seat strap bracket
9. Mounting clip (2)
10. Support casting

Figure 3-200. Saddlebag Supports

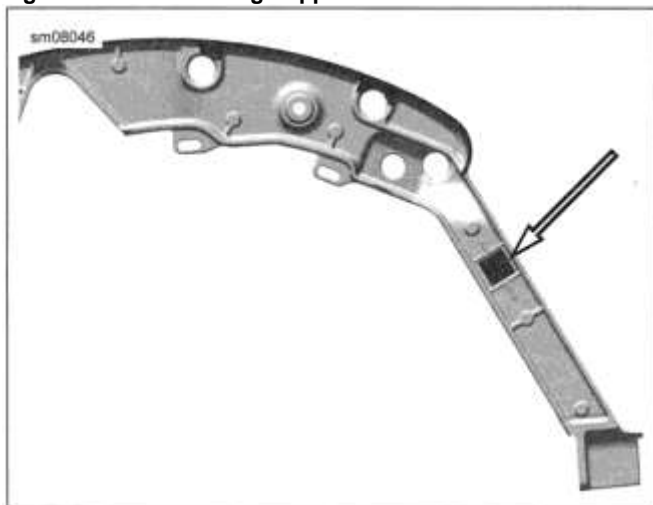


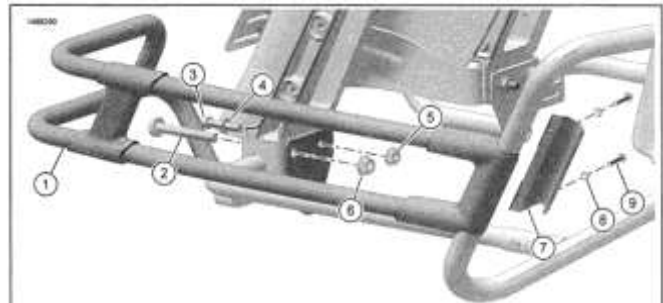
Figure 3-201. Saddlebag Supports Cushion Guard Rail

1. See Figure 3-202. Install rear guard rail to saddlebag support.
  - a. Secure saddlebag guard rail (1) with short screw (3), large lockwasher (4) and nut (5). Leave fasteners loose.
  - b. Install original equipment (OE) long screw (2) and nut (6). Leave fasteners loose.
2. Install front guard rail to saddlebag support.
  - a. Position front of saddlebag guard rail (1) onto support assembly.

- b. Secure with clamp (7), small lockwashers (8) and screws (9).
- c. Tighten screws (9).

Torque: 65 in-lbs (7.3 N-m) *Front Clamp Screw*

3. Tighten screw (2) and nut (6).  
Torque: 30-37 ft-lbs (40.7-50.2 N-m) *Rear Outboard Screw*
4. Tighten screw (3) and nut (5).  
Torque: 15-20 ft-lbs (20.3-27.1 N-m) *Rear Inboard Screw*
5. Repeat installation for opposite side.



1. Saddlebag guard rail
2. Long screw
3. Short screw
4. Large lockwasher
5. Small nut
6. Large nut
7. Clamp
8. Small lockwasher (2)
9. Screw (2)

Figure 3-202. Saddlebag Guard Rail

### COMPLETE

1. Secure muffler to bracket with fasteners and lockwashers. Tighten.

| FASTENER                            | TORQUE VALUE |             |
|-------------------------------------|--------------|-------------|
| Muffler to saddlebag support screws | 14-18 ft-lbs | 19-24.4 N-m |

Torque: 14-18 ft-lbs (19-24.4 N-m) *Muffler to saddlebag support screws*

2. Install seat. See SEAT (Page 3-148).
3. Install main fuse. See POWER DISCONNECT (Page 8-8).
4. Install left side cover. See LEFT SIDE COVER (Page 3-62).
5. Install left and right saddlebags. See SADDLEBAGS (Page 3-163).





°C).

| PART NUMBER | CONSUMABLE                          |
|-------------|-------------------------------------|
|             | 3M GENERAL PURPOSE ADHESIVE REMOVER |

1. Mark location of emblem with masking tape.

## **REMOVE**

2. Remove emblem using fishing line or waxed dental floss.

### *NOTE*

*Wear protective gloves.*

3. Remove remaining foam backing tape and adhesive from mounting surface.

Consumable: 3M GENERAL PURPOSE ADHESIVE REMOVER()

### *NOTE*

- *Do not clean with denatured alcohol, mineral spirits or other solvents. Damage to components may occur.*
  - *For maximum bond, surface must be clean and dry*
4. Clean with a mixture of 50 percent isopropyl alcohol and 50 percent distilled water.

## **INSTALL**

---

### *NOTE*

- *Apply in ambient temperatures between 70-100 °F (21-38*

- *Parts cannot be repositioned after initial installation. Do not remove protective film from adhesive until ready to apply*
- *Do not bend emblem to fit contour of mounting surface.*
- *Allow at least 24 hours after application before exposing the area to vigorous washing, strong water spray or extreme weather.*
- *The adhesive bond will increase to maximum strength after about 72 hours at normal room temperature.*

1. Test fit medallion.

- a. Check medallion against curve of mounting surface.
- b. Match left and right sides of fuel tank or top cover, as applicable.

2. Remove protective film from back of medallion.

*NOTE*

- *Protect adhesive from grease, oil, dust, dirt and fingerprints.*
  - *Once applied, do not shift medallion.*
3. Apply even pressure across entire surface. Hold in place for 15 seconds.
  4. Wait 20 minutes before touching medallion.

## NOTES

| SUBJECT                                   | PAGE NO. |
|---|----------|
| 4.1 FASTENER TORQUE VALUES .....          | 4-1      |
| 4.2 SPECIFICATIONS .....                  | 4-3      |
| 4.3 ENGINE OIL FLOW .....                 | 4-6      |
| 4.4 OIL PUMP OPERATION .....              | 4-9      |
| 4.5 BREATHER OPERATION .....              | 4-10     |
| 4.6 OIL PRESSURE .....                    | 4-11     |
| 4.7 TROUBLESHOOTING .....                 | 4-12     |
| 4.8 CRIMP CLAMPS.....                     | 4-16     |
| 4.9 OIL COOLER.....                       | 4-17     |
| 4.10 OIL CHECK VALVE .....                | 4-19     |
| 4.11 OIL COOLANT LINES .....              | 4-20     |
| 4.12 FRONT ENGINE MOUNT.....              | 4-22     |
| 4.13 UPPER ROCKER COVERS .....            | 4-24     |
| 4.14 BREATHERS.....                       | 4-26     |
| 4.15 LOWER ROCKER COVERS .....            | 4-28     |
| 4.16 ROCKER ARMS .....                    | 4-30     |
| 4.17 PUSHRODS, LIFTERS AND COVERS .....   | 4-32     |
| 4.18 CYLINDER HEADS .....                 | 4-36     |
| 4.19 CYLINDERS .....                      | 4-42     |
| 4.20 PISTONS .....                        | 4-46     |
| 4.21 CAM COMPARTMENT AND COMPONENTS ..... | 4-52     |
| 4.22 OIL PUMP.....                        | 4-58     |
| 4.23 REPLACE ENGINE .....                 | 4-61     |
| 4.24 CRANKCASE .....                      | 4-63     |
| 4.25 FLYWHEEL AND CONNECTING RODS.....    | 4-73     |
| 4.26 OIL PAN .....                        | 4-75     |

## NOTES

## FASTENER TORQUE VALUES IN THIS CHAPTER

| FASTENER  | TORQUE VALUE   |               | NOTES  |
|---|----------------|---------------|--|
|   |                |               |  |
| Balancer bearing screw                            | 80-110 in-lbs  | 9-12.4 N-m    | 4.24 CRANKCASE, Repair Right Crankcase Half  |
| Balancer bearing screw                            | 80-110 in-lbs  | 9-12.4 N-m    | 4.24 CRANKCASE, Repair Left Crankcase Half   |
| Breather screw                                    | 90-120 in-lbs  | 10.2-13.6 N-m | 4.14 BREATHERS, Install  |
| Cam chain tensioner fasteners                     | 90-120 in-lbs  | 10.2-13.6 N-m | 4.21 CAM COMPARTMENT AND COMPONENTS, Install   |
| Cam needle bearing installation maximum torque    | 25 ft-lbs      | 33.9 N-m      | 4.21 CAM COMPARTMENT AND COMPONENTS, Camshaft Needle Bearings  |
| Camshaft cover screws                             | 90-120 in-lbs  | 10.2-13.6 N-m | 4.21 CAM COMPARTMENT AND COMPONENTS, Remove and Install: Camshaft Cover  |
| Camshaft sprocket screw, 1st torque               | 15.0 ft-lbs    | 20.3 N-m      | 4.21 CAM COMPARTMENT AND COMPONENTS, Install<br>See procedure to verify alignment specification before tightening. Apply LOCTITE 262 HIGH STRENGTH THREADLOCKER AND SEALANT (red). |
| Camshaft sprocket screw, alignment check torque   | 15.0 ft-lbs    | 20.3 N-m      | 4.21 CAM COMPARTMENT AND COMPONENTS, Install<br>See procedure to verify alignment specification before tightening.   |
| Camshaft sprocket screw, final torque             | 34 ft-lbs      | 46.1 N-m      | 4.21 CAM COMPARTMENT AND COMPONENTS, Install   |
| Camshaft timer cover screws                       | 25-35 in-lbs   | 2.8-4 N-m     | 4.21 CAM COMPARTMENT AND COMPONENTS, Remove and Install: Camshaft Cover  |
| Cam support plate screws                          | 90-120 in-lbs  | 10.2-13.6 N-m | 4.21 CAM COMPARTMENT AND COMPONENTS, Install   |
| Coolant downtube lower screws                     | 20-22 ft-lbs   | 27.1-29.8 N-m | 4.9 OIL COOLER, Install  |
| Coolant downtube upper screws                     | 90-110 in-lbs  | 10.2-12.4 N-m | 4.9 OIL COOLER, Install  |
| Crankcase oil check valve or plug with O-ring     | 18-22 ft-lbs   | 24.4-29.8 N-m | 4.10 OIL CHECK VALVE, Install  |
| Crankcase oil check valve or plug with O-ring     | 18-22 ft-lbs   | 24.4-29.8 N-m | 4.24 CRANKCASE, Plugs and Oil Fittings   |
| Crankcase screws, 1st torque                      | 120 in-lbs     | 13.6 N-m      | 4.24 CRANKCASE, Assemble   |
| Crankcase screws, final torque                    | 15-19 ft-lbs   | 20.3-25.8 N-m | 4.24 CRANKCASE, Assemble   |
| Crankcase tapered plugs                           | 120-144 in-lbs | 13.6-16.3 N-m | 4.24 CRANKCASE, Plugs and Oil Fittings   |
| Crankshaft sprocket screw, 1st torque             | 15.0 ft-lbs    | 20.3 N-m      | 4.21 CAM COMPARTMENT AND COMPONENTS, Install<br>Apply LOCTITE 262 HIGH STRENGTH THREADLOCKER AND SEALANT (red)   |
| Crankshaft sprocket screw, alignment check torque | 15.0 ft-lbs    | 20.3 N-m      | 4.21 CAM COMPARTMENT AND COMPONENTS, Install<br>See procedure to verify alignment specification before tightening.   |
| Crankshaft sprocket screw, final torque           | 24 ft-lbs      | 32.5 N-m      | 4.21 CAM COMPARTMENT AND COMPONENTS, Install   |
| Cylinder head nut torque step 1.                  | 20-30 ft-lbs   | 27.1-40.7 N-m | 4.18 CYLINDER HEADS, Install<br>Apply ENGINE OIL to cylinder head bolt washers and threaded portion of the new cylinder head bolts. See procedure for torque sequence.             |
| Cylinder head nut torque step 2. Loosen one turn. | -360°          | -360°         | 4.18 CYLINDER HEADS, Install   |

| FASTENER  | TORQUE VALUE     |               | NOTES  |
|---|------------------|---------------|--|
| Cylinder head nut torque step 3.                                  | 9-11 ft-lbs      | 12.2-14.9 N-m | 4.18 CYLINDER HEADS, Install   |
| Cylinder head nut torque step 4.                                  | 25-27 ft-lbs     | 33.9-36.6 N-m | 4.18 CYLINDER HEADS, Install   |
| Cylinder head nut torque step 5. Tighten additional degree value. | 90°              | 90°           | 4.18 CYLINDER HEADS, Install   |
| Cylinder stud   | 120-240 in-lbs   | 13.6-27.1 N-m | 4.24 CRANKCASE, Cylinder Studs   |
| Engine mount, lower front, end cap screws                         | 42-48 ft-lbs     | 56.9-65 N-m   | 4.12 FRONT ENGINE MOUNT, Remove and Install: Lower Front Engine Mount  |
| Engine mount, lower front, flange nut                             | 50-55 ft-lbs     | 67.8-74.6 N-m | 4.12 FRONT ENGINE MOUNT, Remove and Install: Lower Front Engine Mount  |
| Engine mount, upper front, stabilizer link screws                 | 30.0-35.0 ft-lbs | 40.7-47.5 N-m | 4.12 FRONT ENGINE MOUNT, Remove and Install: Upper Front Engine Mount  |
| Engine oil drain plug   | 14-21 ft-lbs     | 19-28.5 N-m   | 4.26 OIL PAN, Install  |
| Engine stabilizer bracket screws                                  | 45.0-50.0 ft-lbs | 61-67.8 N-m   | 4.12 FRONT ENGINE MOUNT, Remove and Install: Upper Front Engine Mount  |
| Lifter anti-rotation device screw                                 | 90-120 in-lbs    | 10.2-13.6 N-m | 4.17 PUSHRODS, LIFTERS AND COVERS, Install   |
| Lifter cover screws   | 132-156 in-lbs   | 14.9-17.6 N-m | 4.17 PUSHRODS, LIFTERS AND COVERS, Install   |
| Oil cooler screws   | 96-120 in-lbs    | 10.8-13.6 N-m | 4.9 OIL COOLER, Assemble   |
| Oil line manifold screws  | 90-120 in-lbs    | 10.2-13.6 N-m | 4.11 OIL COOLANT LINES, Install  |
| Oil pan fasteners   | 132-156 in-lbs   | 14.9-17.6 N-m | 4.26 OIL PAN, Install  |
| Oil pan tapered plug  | 30-36 ft-lbs     | 40.7-48.8 N-m | 4.26 OIL PAN, Install  |
| Oil pump screws, 1st torque                                       | 12-60 in-lbs     | 1.4-6.8 N-m   | 4.21 CAM COMPARTMENT AND COMPONENTS, Install   |
| Oil pump screws, final torque                                     | 90-120 in-lbs    | 10.2-13.6 N-m | sm08548<br><br><br><br>Figure 4-54. Cam Support Plate Tightening Sequence |
| Piston jet screws   | 25-35 in-lbs     | 2.8-3.9 N-m   | 4.24 CRANKCASE, Repair Right Crankcase Half  |
| Rocker cover, lower, screws                                       | 90-120 in-lbs    | 10.2-13.6 N-m | 4.15 LOWER ROCKER COVERS, Install  |
| Rocker cover, lower, stud   | 90-120 in-lbs    | 10.2-13.6 N-m | 4.13 UPPER ROCKER COVERS, Install  |
| Rocker cover, lower, stud   | 90-120 in-lbs    | 10.2-13.6 N-m | 4.15 LOWER ROCKER COVERS, Install  |
| Rocker cover, upper, screws                                       | 120-140 in-lbs   | 13.6-15.8 N-m | 4.13 UPPER ROCKER COVERS, Install  |
| Rocker shaft screw  | 23-27 ft-lbs     | 31.2-36.6 N-m | 4.16 ROCKER ARMS, Install  |
| Spark plug  | 89-133 in-lbs    | 10-15 N-m     | 4.7 TROUBLESHOOTING, Compression Test  |
| Transmission drain plug   | 14-21 ft-lbs     | 19-28.5 N-m   | 4.26 OIL PAN, Install  |



**ENGINE**

**Table 4-1. Engine: Oil-Cooled Milwaukee-Eight™ 107 Engine**

| ITEM                | SPECIFICATION  |                      |
|---------------------|--|----------------------|
| Number of cylinders | 2  |                      |
| Type                | 4-cycle, 45 degree V-type Oil-cooled, Single camshaft Single balance shaft |                      |
| Compression ratio   | 10.0:1   |                      |
| Bore                | 3.937 in   | 100 mm               |
| Stroke              | 4.375 in   | 111.1 mm             |
| Displacement        | 107 in <sup>3</sup>  | 1745 cm <sup>3</sup> |
| Fuel requirement    | Premium unleaded   |                      |
| Lubrication system  | Pressurized, dry sump with oil cooler                                      |                      |

**Table 4-2. Engine: Oil-Cooled Milwaukee-Eight™ 114 Engine**

| ITEM                | SPECIFICATION  |                      |
|---------------------|--|----------------------|
| Number of cylinders | 2  |                      |
| Type                | 4-cycle, 45 degree V-type Oil-cooled, Single camshaft Single balance shaft |                      |
| Compression ratio   | 10.5:1   |                      |
| Bore                | 4.016 in   | 102 mm               |
| Stroke              | 4.500 in   | 114.3 mm             |
| Displacement        | 114 in <sup>3</sup>  | 1868 cm <sup>3</sup> |
| Fuel requirement    | Premium unleaded   |                      |
| Lubrication system  | Pressurized, dry sump with oil cooler                                      |                      |

**Table 4-3. Engine: Twin-Cooled™ Milwaukee-Eight™ 114 Engine**

| ITEM                | SPECIFICATION   |                      |
|---------------------|---|----------------------|
| Number of cylinders | 2   |                      |
| Type                | 4-cycle, 45 degree V-type Twin-cooled, Single camshaft Single balance shaft         |                      |
| Compression ratio   | 10.5:1  |                      |
| Bore                | 4.016 in  | 102 mm               |
| Stroke              | 4.500 in  | 114.3 mm             |
| Displacement        | 114 in <sup>3</sup>   | 1868 cm <sup>3</sup> |
| Fuel requirement    | Premium unleaded  |                      |
| Lubrication system  | Pressurized, dry sump   |                      |
| Cooling system      | Liquid-cooled cylinder heads with lower fairing-mounted radiators and electric pump |                      |

**Table 4-4. Engine Idle Characteristics**

| CONDITION               | DOM*                         | ALL OTHERS * |
|-------------------------|------------------------------|--------------|
| Cold start              | 1450 rpm                     | 1700 rpm     |
| Hot idle (107ci)        | 850 rpm                      | 850 rpm      |
| Hot idle (114ci)        | 950 rpm                      | 950 rpm      |
| Hot idle; EITMS engaged | 950 rpm                      | 950 rpm      |
| Low voltage             | 200 rpm increase from normal |              |
| Trike in reverse        | 1100 rpm                     | 1100 rpm     |

\* All values are approximate

**Table 4-5. Oiling System**

| ITEM                 | SPECIFICATION  |  |
|----------------------|--|--|
| Capacity with filter | Twin-cooled (new system): 5.0 qt (4.7 L)   |  |
|                      | Oil-cooled (new system): 5.2 qt (4.9 L)  |  |
|                      | Service oil change (all): 4.8 qt (4.5 L)   |  |
| Recommended oil      | Genuine Harley-Davidson H-D 360 Motorcycle Oil or SCREAMIN' EAGLE SYN3 FULL SYNTHETIC MOTORCYCLE LUBRICANT 20W50 |  |
| Pump                 | Twin gerotor, dual scavenge, crank mounted and driven, internal oil pump, dry sump                               |  |
| Pressure             | 35-45 psi (241-310 kPa) at 2000 RPM and normal operating temperature of 230 °F (110 °C)                          |  |
| Filtration           | 5 micron media, filtered between pump and engine   |  |
| Cooling              | Oil cooler (Oil-cooled models only)  |  |

**Table 4-6. Rocker Arms Specifications**

| ROCKER ARMS                  | IN            | MM          |
|------------------------------|---------------|-------------|
| Shaft fit in bushing (loose) | 0.0005-0.0022 | 0.013-0.056 |
| End clearance                | 0.004-0.015   | 0.10-0.38   |

**Table 4-7. Rocker Arm Shaft Specifications**

| ROCKER ARM SHAFTS | IN            | MM            |
|-------------------|---------------|---------------|
| Diameter          | 0.5538-0.5543 | 14.067-14.079 |

**Table 4-8. Hydraulic Lifter Specifications**

| HYDRAULIC LIFTERS        | IN            | MM          |
|--------------------------|---------------|-------------|
| Fit in crankcase (loose) | 0.0009-0.0026 | 0.023-0.066 |

**Table 4-9. Cylinder Head Specifications**

| CYLINDER HEAD                  | IN      | MM     |
|--------------------------------|---------|--------|
| Head gasket surface (flatness) | 0-0.003 | 0-0.08 |

**Table 4-10. Valve Specifications**

| VALVES                                  | IN          | MM            |
|---|-------------|---------------|
| Exhaust: fit in guide                   | 0.001-0.003 | 0.0254-0.0762 |
| Intake: fit in guide                    | 0.001-0.003 | 0.0254-0.0762 |
| Seat width                              | 0.040-0.080 | 1.02-2.03     |
| Stem protrusion from cylinder head boss | 1.714-1.721 | 43.54-43.71   |
| Valve lash *                            | 0.000-0.003 | 0.00-0.08     |

\* Variation between valve pairs operated by a common rocker arm.

**Table 4-11. Valve Spring Specifications**

| VALVE SPRINGS | IN                  | MM              |
|---------------|---------------------|-----------------|
| Closed        | 63 lbs @ 1.535 in.  | 280 N @ 39.0 mm |
| Open          | 165 lbs @ 1.154 in. | 735 N @ 29.3 mm |
| Free length   | 1.838 in.           | 46.69 mm        |

**Table 4-12. Piston**

| PISTON                 |                   | IN            | MM          |
|------------------------|-------------------|---------------|-------------|
| Fit in cylinder        |                   | 0.0025-0.0036 | 0.064-0.091 |
| Piston pin fit (loose) |                   | 0.0002-0.0005 | 0.005-0.013 |
| Ring end gap           | Top compression   | 0.010-0.016   | 0.25-0.40   |
|                        | 2nd compression   | 0.016-0.024   | 0.40-0.60   |
|                        | Oil control ring  | 0.008-0.028   | 0.20-0.70   |
| Ring side clearance    | Top compression   | 0.0012-0.0027 | 0.030-0.068 |
|                        | 2nd compression   | 0.0012-0.0027 | 0.030-0.068 |
|                        | Oil control rails | 0.001-0.007   | 0.025-0.178 |

**Table 4-13. Connecting Rod Specifications**

| CONNECTING ROD               | IN                 | MM                |
|------------------------------|--------------------|-------------------|
| Piston pin fit (loose)       | 0.0007-0.0012      | 0.018-0.030       |
| Side play between fly-wheels | greater than 0.005 | greater than 0.13 |

**Table 4-14. Flywheel Specifications**

| FLYWHEELS                         | IN          | MM          |
|-----------------------------------|-------------|-------------|
| Runout (shaft measured in case)   | 0.000-0.010 | 0.0-0.254   |
| Runout (measured in truing stand) | 0.000-0.004 | 0.0-0.102   |
| End play                          | 0.003-0.013 | 0.076-0.330 |

**Table 4-15. Crankshaft/Sprocket Shaft Bearing Specifications**

| CRANKSHAFT/SPROCKET SHAFT BEARINGS       | IN            | MM          |
|--|---------------|-------------|
| Roller bearing fit (loose)               | 0.0002-0.0015 | 0.005-0.038 |
| Bearing fit in crankcase (tight)         | 0.0038-0.0054 | 0.097-0.137 |
| Bearing inner race on crankshaft (tight) | 0.0004-0.0014 | 0.010-0.036 |

**SERVICE WEAR LIMITS**

Wear limits are given here as a guideline for measuring used engine components. Replace components when they exceed these values.

**Table 4-16. Rocker Arm/Rocker Arm Shaft**

| ROCKER ARM/ROCKER ARM SHAFT | REPLACE IF WEAR EXCEEDS |       |
|-----------------------------|-------------------------|-------|
|                             | IN                      | MM    |
| Shaft fit in bushing        | 0.006                   | 0.152 |
| End clearance               | 0.025                   | 0.635 |

**Table 4-17. Hydraulic Lifter**

| HYDRAULIC LIFTER     | REPLACE IF WEAR EXCEEDS |       |
|----------------------|-------------------------|-------|
|                      | IN                      | MM    |
| Fit in crankcase     | 0.006                   | 0.152 |
| Roller fit           | 0.0015                  | 0.038 |
| Roller end clearance | 0.022                   | 0.559 |

**Table 4-18. Cam Support Plate**

| ITEM                               | REPLACE IF WEAR EXCEEDS |           |
|------------------------------------|-------------------------|-----------|
|                                    | IN                      | MM        |
| Cam chain tensioner shoe thickness | 0.060 min.              | 1.52 min. |
| Crankshaft bore maximum ID         | 0.8545                  | 21.704    |
| Camshaft bore                      | 1.1023                  | 27.998    |
| Flatness                           | 0.010                   | 0.25      |

**Table 4-19. Oil Pump**

| OIL PUMP                  | REPLACE IF WEAR EXCEEDS |       |
|---------------------------|-------------------------|-------|
|                           | IN                      | MM    |
| Rotor tip clearance       | 0.004                   | 0.10  |
| Rotor thickness variation | 0.001                   | 0.025 |

**Table 4-20. Cylinder Head**

| CYLINDER HEAD               | REPLACE IF |       |
|-----------------------------|------------|-------|
|                             | IN         | MM    |
| Valve seat width (max)      | 0.080      | 2.03  |
| Valve margin (min)          | 0.031      | 0.80  |
| Valve stem protrusion (max) | 1.752      | 44.50 |
| Cylinder head warpage (max) | 0.006      | 0.152 |
| Valve lash (max)*           | 0.008      | 0.20  |

\* Variation between valve pairs operated by a common rocker arm.

**Table 4-21. Valve Stem to Guide**

| VALVE STEM TO GUIDE | REPLACE IF WEAR EXCEEDS |        |
|---------------------|-------------------------|--------|
|                     | IN                      | MM     |
| Intake              | 0.0038                  | 0.0965 |
| Exhaust             | 0.0038                  | 0.0965 |

**Table 4-22. Valve Springs**

| VALVE SPRINGS | IN                         | MM                  |
|---------------|----------------------------|---------------------|
| Closed        | 56.8-66.1 lbs @1.154 in    | 253-294 N @29.3 mm  |
| Open          | 150.0-172.7 lbs @ 1.091 in | 667-768 N @27.70 mm |
| Free length   | 1.838 in                   | 46.70 mm            |

**Table 4-23. Cylinder**

| CYLINDER                        | REPLACE IF WEAR EXCEEDS |       |
|---------------------------------|-------------------------|-------|
|                                 | IN                      | MM    |
| Warpage of gasket surface: top  | 0.006                   | 0.152 |
| Warpage of gasket surface: base | 0.004                   | 0.102 |

**Table 4-24. Piston**

| PISTON                  | REPLACE IF WEAR EXCEEDS |       |       |
|-------------------------|-------------------------|-------|-------|
|                         | IN                      | MM    |       |
| Fit in cylinder (loose) | 0.0041                  | 0.104 |       |
| Piston pin fit (loose)  | 0.0008                  | 0.020 |       |
| Ring end gap            | Top compression         | 0.020 | 0.508 |
|                         | Second compression      | 0.030 | 0.762 |
|                         | Oil control rails       | 0.050 | 1.27  |
| Ring side clearance     | Top compression         | 0.004 | 0.102 |
|                         | Second compression      | 0.004 | 0.102 |
|                         | Oil control rails       | 0.010 | 0.254 |

**Table 4-25. Connecting Rod**

| CONNECTING ROD         | REPLACE IF WEAR EXCEEDS |       |
|------------------------|-------------------------|-------|
|                        | IN                      | MM    |
| Piston pin fit (loose) | 0.002                   | 0.051 |

**Table 4-26. Flywheel**

| FLYWHEEL                          | REPLACE IF WEAR EXCEEDS |       |
|-----------------------------------|-------------------------|-------|
|                                   | IN                      | MM    |
| Runout (shaft measured in case)   | 0.012                   | 0.305 |
| Runout (measured in truing stand) | 0.005                   | 0.127 |
| End play                          | 0.013                   | 0.330 |

**Table 4-27. Crankshaft Roller Bearing**

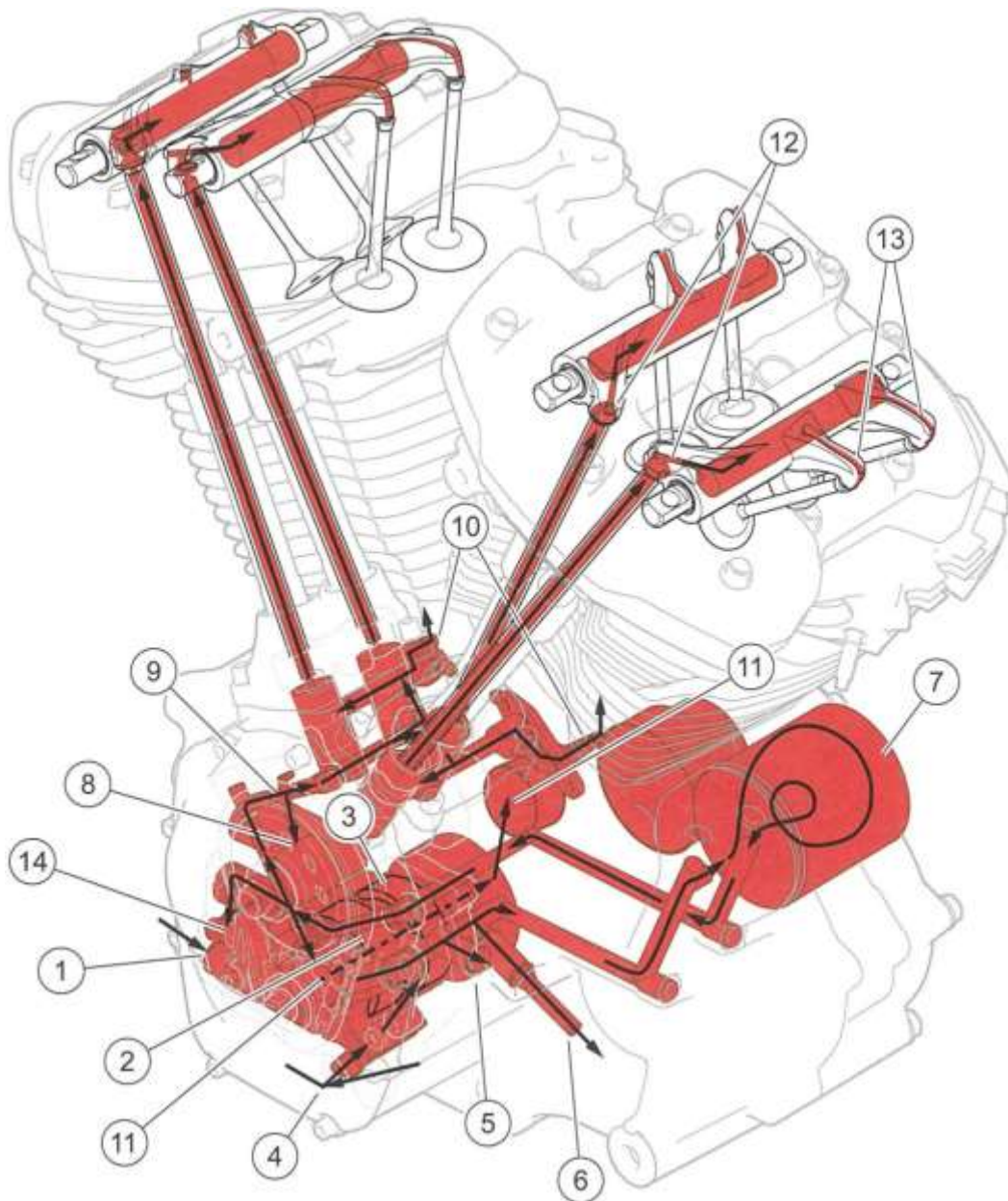
| CRANKSHAFT ROLLER BEARING        | REPLACE IF       |                 |
|----------------------------------|------------------|-----------------|
|                                  | IN               | MM              |
| Roller bearing fit (loose)       | More than 0.0015 | More than 0.038 |
| Bearing fit in crankcase (tight) | Less than 0.0038 | Less than 0.097 |
| Inner race on crankshaft (tight) | Less than 0.0004 | Less than 0.010 |

## OPERATION

Milwaukee-Eight engines are dry sump engines meaning they have external oil reservoirs. Oil-cooled engines have an oil cooler and circulate oil between exhaust ports for additional heat control.

### **Internal Oil Distribution: All**

1. See Figure 4-1.
  - a. Oil from the oil pan (1) is pulled through ports in the oil pan (not shown), transmission housing and crankcase
  - b. Oil enters oil pump feed gerotors.
  - c. Oil exits pump and passes oil pressure switch (5) and oil cooler port (6) headed to oil filter (7). Oil cooler port is plugged on Twin-cooled engines.
  - d. Oil exits filter and is directed back into cam support plate where its split between crankshaft, hydraulic chain tensioner (14), and lifters (9).
  - e. Crankshaft oil travels through crankshaft to crankpin and rod bearings (11).
  - f. Flow toward lifters splits to cam plain bearing (8), lifters and to piston jets (10).
  - g. Oil flows from lifters up through pushrods to rocker arms (12).
  - h. Oil exits rocker arms to lubricate valve stems via spillover (13).
  - i. Oil drains through passages in heads to cylinders, back to camchest cavity. Residual oil in camchest cavity and crankcase cavity is picked up through scavenge port (4) in pump. Return oil is fed through scavenge gerotors and case passages back to oil pan.
  - j. Main bearings, balancer bearing and left cam bearing are lubricated by oil splash.

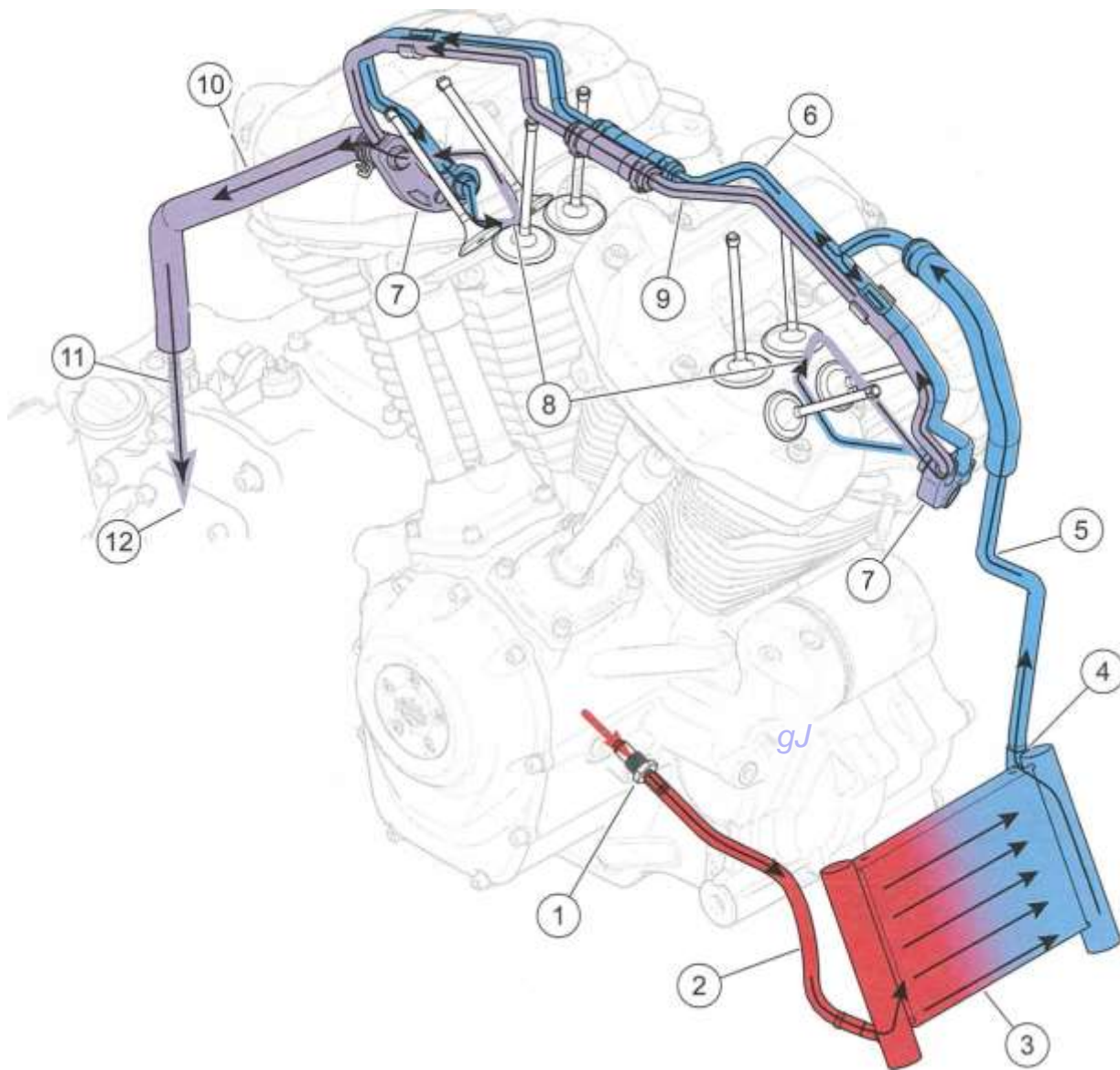


- |  |   |
|--|---|
| <ol style="list-style-type: none"> <li>1. Oil in from oil pan</li> <li>2. Oil pump feed rotors</li> <li>3. Oil pump scavenge rotors</li> <li>4. Scavenge oil in from cam chest</li> <li>5. Oil pressure switch</li> <li>6. Oil out to oil cooler (oil cooled only)</li> <li>7. Oil filter</li> </ol> | <ol style="list-style-type: none"> <li>8. Cam plain bearing</li> <li>9. Oil to camshaft, lifters and piston jets</li> <li>10. Piston jets</li> <li>11. Oil through crankshaft to crankpin and rod bearings</li> <li>12. Oil through pushrods to rocker arms</li> <li>13. Oil spillover to lubricate valve stems</li> <li>14. Hydraulic chain tensioner</li> </ol> |
|--|---|

**Figure 4-1. Internal Engine Oil Flow**

**External Oil Distribution: Oil-Cooled Only**

1. See Figure 4-2.
  - a. Pressurized oil exits crankcase and flows through check valve (1), hose (2) to oil cooler (3).
  - b. Oil flows through oil cooler, hose (4) to downtube (5).
  - c. Oil flow splits at oil supply line (6) and flows to manifolds (7).
  - d. Oil flows through passages between exhaust ports (8) in cylinder heads and back to manifolds.
  - e. Oil flows through return line (9) to rear hose (10).
  - f. Rear hose connects to passage (11) in transmission then returns to oil pan (12).



- |                                 |                                  |
|---------------------------------|----------------------------------|
| 1. Oil out check valve          | 7. Manifold                      |
| 2. Hose, engine to oil cooler   | 8. Passages around exhaust ports |
| 3. Oil cooler                   | 9. Return oil line               |
| 4. Hose, oil cooler to downtube | 10. Rear oil hose                |
| 5. Downtube                     | 11. Passage through transmission |
| 6. Supply oil line              | 12. Return oil to oil pan        |

Figure 4-2. External Engine Oil Flow: Air Cooled

## GENERAL

See Figure 4-3. The oil pump has two crankshaft driven gerotor gear sets.

- The feed gerotor set distributes engine oil.
- The scavenge gerotor set draws oil from the cam and flywheel compartments and returns it to the oil pan.

Each gerotor gear set has an inner and outer gerotor. The inner and outer gerotors have fixed centers that are slightly offset to one another. The inner gerotor has one less tooth.

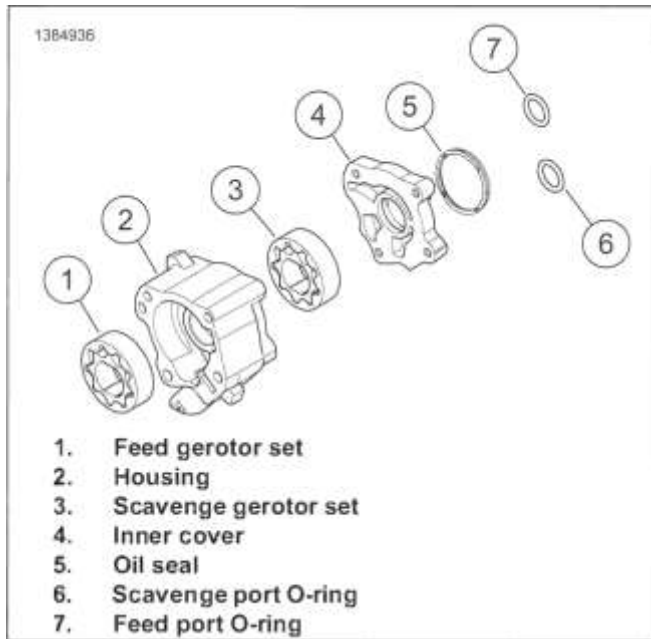


Figure 4-3. Oil Pump OPERATION

The oil pump is crankshaft driven. Pump inlet and outlet sides are sealed by tips and lobes of inner and outer gerotors, preventing outlet side (high pressure) oil from being transferred to the inlet side.

See Figure 4-4. As gerotors rotate, cavity volume increases between inner and outer gerotors on pump inlet side. A vacuum is created causing oil to be drawn in. The cavity increases until the volume is equivalent to that of missing tooth on inner gerotor.

See Figure 4-5. As oil moves to pump outlet side, the cavity decreases in volume. Pressurized oil is forced out the discharge port. In operation, gerotors provide continuous oil flow.

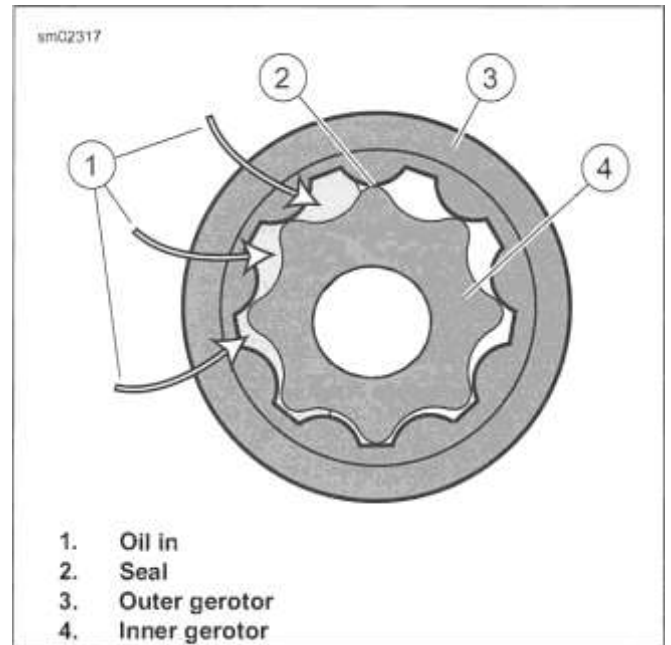


Figure 4-4. Inlet Side Oil Flow

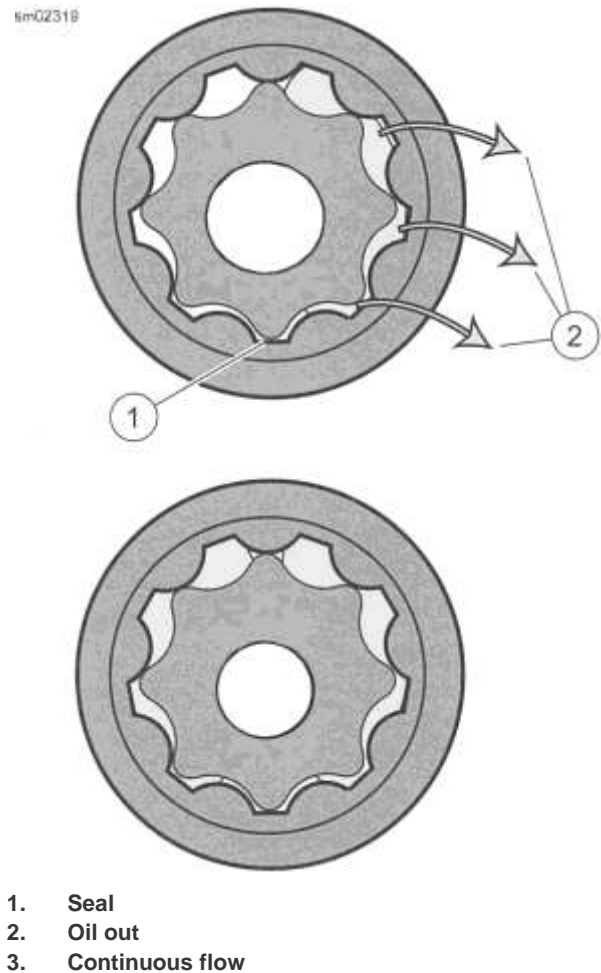


Figure 4-5. Outlet Side Oil Flow

## GENERAL

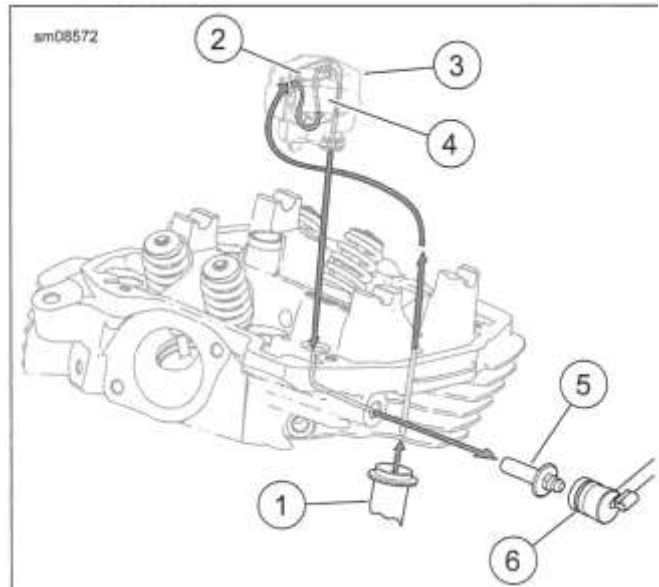
A breather assembly is mounted to each cylinder head to prevent a buildup of pressure caused by the downward force of the pistons. Burning crankcase vapor eliminates the pollutants normally discharged from the crankcase.

See Figure 4-6. As pistons push downward, displaced air in the crankcase is vented through the crankshaft roller bearing into the cam compartment. The air flows up the pushrod covers (1) into the rocker housing. The moving air absorbs a small amount of oil vapor as it travels through the engine.

The oil/air vapor passes through an opening in the breather assembly (3).

In the breather assembly, the flow of air passes downward through a labyrinth where most of the oil is separated from the air. It then moves upward through the breather element (4) where the remaining oil is removed. Two small holes in the bottom of the breather housing allow the separated oil to drain back into the crankcase.

Passing through the breather element, the vapor passes through the umbrella valve (2). Vapor passes down into the cylinder head passageway and through the breather bolt (5). It passes through a breather tube (6) into the air filter element where it combines with the intake air stream and is burned during normal combustion.



1. Pushrod cover
2. Umbrella valve
3. Breather assembly
4. Breather element
5. Breather bolt
6. Breather tube

Figure 4-6. Breather Air Flow



## OPERATION

See Figure 4-7. The red OIL PRESSURE indicator lamp illuminates to warn of improper engine oil pressure. The lamp illuminates when the ignition is initially turned on (before engine is started), but should extinguish once engine is running.

### NOTICE

If the oil pressure indicator lamp remains lit, always check the oil supply first. If the oil supply is normal and the lamp is still lit, stop the engine at once and do not ride further until the trouble is located and the necessary repairs are made. Failure to do so may result in engine damage. (00157a)

If indicator lamp does not extinguish, it may be caused by low oil level or diluted oil supply. In freezing weather, the oil feed and return lines can clog with ice or sludge. Other conditions that may cause lamp to remain lit are:

- Faulty lamp wiring
- Faulty oil pressure sending unit
- Damaged oil pump
- Plugged oil filter element
- Incorrect oil viscosity for the operating temperature
- Fractured or weak spring in the oil pressure relief valve

- Incorrectly installed O-rings in the engine

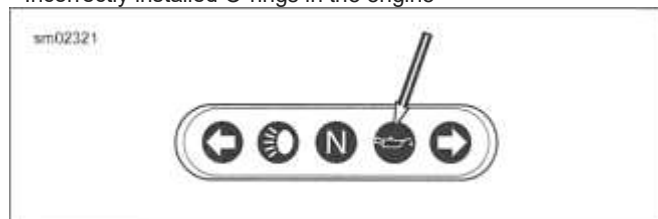


Figure 4-7. Oil Pressure Indicator Lamp

## OIL PRESSURE CHECK

1. Verify that engine oil is at the proper level. See REPLACE

| PART NUMBER  | TOOL NAME                   |
|--------------|-----------------------------|
| HD-96921-52D | OIL PRESSURE TEST GAUGE KIT |

ENGINE OIL AND FILTER (Page 2-9).

2. Run motorcycle until engine oil reaches specification.  
Temperature: 230 °F (110 °C)
3. Stop Engine.
4. Remove oil pressure switch from crankcase. See OIL PRESSURE SWITCH (Page 8-36).

5. See Figure 4-8. Install test kit.

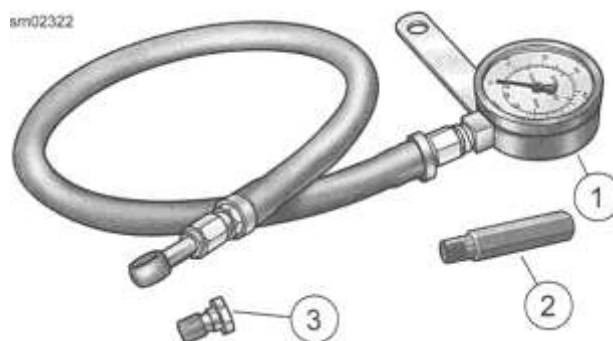
Special Tool: OIL PRESSURE TEST GAUGE KIT (HD-96921-52D)

- a. Hand-tighten adapter HD-96921-106 (2) in oil pressure switch mounting hole.
- b. Assemble banjo bolt (3), washer (4), oil pressure gauge (1), banjo fitting and second washer onto adapter. Hand-tighten.
6. Check oil pressure.
  - a. Operate engine at various speeds.
  - b. Record results.
  - c. Stop engine.
7. Verify that oil pressure is within specifications. Refer to Table 4-28.
8. Remove oil pressure gauge assembly.
9. Install oil pressure switch. See OIL PRESSURE SWITCH

Table 4-28. Oil Pressure

| CHECK                             | SPECIFICATION * |             |
|-----------------------------------|-----------------|-------------|
|                                   | SAE             | METRIC      |
| Oil pressure - min at idle        | 5 psi           | 34.5 kPa    |
| Oil pressure - normal at 2000 rpm | 35-45 psi       | 242-310 kPa |
| Oil pressure - max                | 50 psi          | 345 kPa     |

\* With oil at normal operating temperature of 230 °F (110 °C)



(Page 8-36).

1. Gauge
2. Adapter
3. Banjo bolt
4. Washer (2)

Figure 4-8. Oil Pressure Gauge Set

**TYPICAL SYMPTOMS**

**Typical Symptoms**

Symptoms indicating a need for engine repair are often misleading. If more than one symptom is present, possible causes can be narrowed to make at least a partial diagnosis.

For example, an above normal consumption of oil could be caused by several mechanical faults. However when accompanied by blue-gray smoke from the exhaust and low compression, it indicates piston rings need replacing. Low compression by itself is more likely to be caused by improperly seated or burned valves, not worn rings.

Certain knocking noises may occur because of loose bearings, others by piston slap. Piston slap is a condition where piston or cylinder or both are out of tolerance. This excessive clearance allows the piston to slap the cylinder as it moves up and down.

Most frequently, valves, rings, pins, bushings and bearings need attention at about the same time. If symptoms indicate any mentioned components are worn, service all related parts.

**COMPRESSION TEST**

| PART NUMBER | TOOL NAME                  |
|-------------|----------------------------|
| HD-33223-1  | CYLINDER COMPRESSION GAUGE |
| HD-50549    | BORESCOPE                  |

| FASTENER   | TORQUE VALUE  |           |
|------------|---------------|-----------|
| Spark plug | 89-133 in-lbs | 10-15 N-m |

1. Remove all spark plug cables.
2. Remove one spark plug from each cylinder.
 

*NOTE*

*Never use a metal object to hold throttle plate open.*
3. Open throttle plate.
  - a. Remove air cleaner cover and filter. See INSPECT AIR FILTER (Page 2-46).
  - b. Disconnect TCA connector [211] from induction module.
  - c. Mechanically hold throttle plate open.
4. Test compression.
  - a. Connect compression tester to front cylinder.  
Special Tool: CYLINDER COMPRESSION GAUGE (HD-33223-1)
  - b. Crank engine continuously through 5-7 full compression strokes.
  - c. Note gauge readings at end of first and last compression strokes. Record test results.
  - d. Disconnect ACR and repeat test.

- e. Connect ACR.
5. Repeat test on rear cylinder.
6. Compare with specifications. Refer to Table 4-29
  - a. If compression is within specifications and variance between cylinders is less than 10%, compression is normal.
  - b. If readings do not meet specifications, inject engine oil into each cylinder and repeat test on both cylinders. Readings that are considerably higher during second test indicate worn piston rings.  
  
Volume: 0.5 fl oz (15 ml)
  - c. Refer to Table 4-30 for possible causes of low compression.
7. Inspect cylinder using borescope. See Clean and Inspect (Page 4-44) for more detail.  
  
Special Tool: BORESCOPE (HD-50549)
8. Release throttle plate.
9. Connect TCA connector.
10. Assemble air cleaner. See INSPECT AIR FILTER (Page 2-46).
11. Install spark plugs. Connect spark plug wires.  
  
Torque: 89-133 in-lbs (10-15 N-m) *Spark plug*

**CYLINDER LEAKDOWN TEST**

**Table 4-29. Compression Specifications**

| ACR STATUS       | PSI       | kPa        |
|------------------|-----------|------------|
| ACR connected    | 90 (min)  | 621 (min)  |
| ACR disconnected | 175 (min) | 1207 (min) |

**Table 4-30. Compression Test Results**

| TEST RESULTS  | DIAGNOSIS   |
|---|---|
| <ul style="list-style-type: none"> <li>• Compression low on first stroke.</li> <li>• Compression builds on the following strokes, but does not reach normal.</li> <li>• Improves considerably when oil is added to cylinder.</li> </ul> | - Ring trouble  |
| <ul style="list-style-type: none"> <li>• Compression low on first stroke.</li> <li>• Compression does not build much on following strokes.</li> <li>• Does not improve considerably with the addition of oil.</li> </ul>                | - Head gasket leak<br>- Incorrect valve lash<br>- Valve trouble |

| PART NUMBER | TOOL NAME                |
|-------------|--------------------------|
| HD-35667-A  | CYLINDER LEAKDOWN TESTER |
| HD-50549    | BORESCOPE                |
| HD-52252    | CRANKSHAFT LOCKING TOOL  |

1. Verify that leakdown tester is free from leakage.  
Special Tool: CYLINDER LEAKDOWN TESTER (HD-35667-A)
  - a. Connect cylinder leakdown tester to compressed air source.
  - b. Apply a soap/water solution around all tester fittings.
  - c. Inspect connections for bubbles indicating leaks.

2. **NOTE**

*Perform test with ignition switch turned OFF*

Remove one spark plug per cylinder.

3. Set piston in cylinder being tested at top dead center (TDC) of compression stroke (all valves closed).
4. Lock the crankshaft.
  - a. Remove CKP. See CRANKSHAFT POSITION SENSOR (CKP) (Page 8-95).
  - b. Install crankshaft locking tool.

Special Tool: CRANKSHAFT LOCKING TOOL (HD-52252)

5. Perform leakdown test.
  - a. Record percent of leakage.
  - b. Listen for air leaks at throttle body, exhaust pipe, oil fill spout and head gasket.

6. Verify that piston is still at TDC. Repeat test if moved.

7. Results:

- a. Leakage greater than 25 percent indicates further diagnosis is warranted.
- b. Air escaping through throttle body indicates leaking past intake valves.
- c. Air escaping through exhaust pipe indicates leaking past exhaust valves.
- d. Air sound from oil fill spout indicates leaking past piston rings.
- e. Inspect cylinder using borescope. Refer to Clean and Inspect (Page 4-44) for more detail.

Special Tool: BORESCOPE (HD-50549)

8. Remove crankshaft locking tool.

**MEASURE CRANKSHAFTRUNOUT**

**Flywheel Assembly Installed**

*NOTE*

- Perform the following checks during engine disassembly as a method to determine flywheel assembly suitability for reuse.
- The checks can be done with engine either installed or removed.
- Dial indicators must be 90 degrees when viewed from the end and from the side.
- For a reliable reading, only measure on the cam support plate bushing machined surface of the crankshaft, never on a shaft adapter.
- Never secure dial indicator base to vehicle frame. Movement within engine mounts will result in false readings.
- While rotating crankshaft, indicator needle may move to both minus and plus sides of zero. Total indicator reading is the value to record.

**Right Side**

1. Remove one spark plug from each cylinder.
2. Remove cam support plate. See CAM COMPARTMENT AND COMPONENTS (Page 4-52).
3. Secure a dial indicator base with dial indicator to a stable location (crankcase, engine stand, etc.).
4. See Figure 4-9. Adjust dial indicator position to measure runout at cam plate bearing contact area (4).
5. Adjust indicator to zero.
6. Slowly rotate flywheel assembly one complete revolution. Record total needle movement.
7. Refer to Table 4-31. If total indicator reading exceeds service wear limit, remove flywheel assembly to check on truing stand.

**Left Side**

1. Remove one spark plug from each cylinder.
2. Remove primary cover and compensating sprocket. See DRIVE COMPONENTS (Page 5-16).
3. Secure a dial indicator base with dial indicator to a stable location (crankcase, engine stand, etc.).
4. See Figure 4-9. Adjust dial indicator position to measure "high" part of splines (5) on shaft.
5. Adjust indicator to zero.
6. Slowly rotate crankshaft one complete revolution. Record total difference of raised spline measurements.
7. Refer to Table 4-31. If total indicator reading exceeds service wear limit, remove flywheel assembly to check on truing stand.

**Flywheel Assembly Removed**

*NOTE*

- Verify bearing races are in good condition before performing

*this inspection.*

1. See Figure 4-9. Mount flywheel assembly in truing stand with bearing races (1) on roller supports (2).
2. Secure dial indicator (3) and mount near each end of flywheel assembly.
3. Set up each indicator (3) to measure the machined surface (4) on one end and splines (5) on the other.
4. Adjust both indicators to zero.
5. Slowly rotate flywheel assembly while observing total indicator reading.
6. Refer to Table 4-31. Compare measurements.
  - a. If total indicator reading exceeds service wear limit, replace flywheel assembly.
  - b. If total indicator reading does not exceed service wear limit, examine left and right main bearings. See CRANKCASE (Page 4-63).

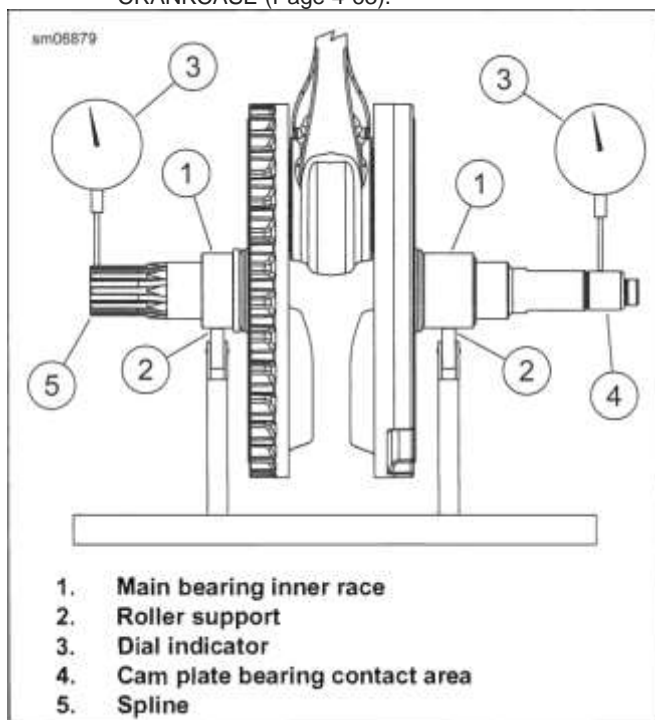


Figure 4-9. Checking Crankshaft Runout

Table 4-31. Flywheel

| FLYWHEEL                          | REPLACE IF WEAR EXCEEDS |       |
|-----------------------------------|-------------------------|-------|
|                                   | IN                      | MM    |
| Runout (shaft measured in case)   | 0.012                   | 0.305 |
| Runout (measured in truing stand) | 0.005                   | 0.127 |
| End play                          | 0.013                   | 0.330 |

## DIAGNOSE VALVE TRAIN NOISE

1. **NOTE**  
Some valve train noise at start-up is normal until lifters fill with oil. Continuous noise requires diagnosis.

With engine and oil at normal operating temperature, check oil pressure at 2000 rpm.

2. Check oil pressure. See Oil Pressure Check (Page 4-11).
3. If oil pressure is outside of range, inspect following:
  - a. Oil pump wear
  - b. Crankcase passages for blockages
  - c. Oil hoses for blockages
4. If oil-starved hydraulic lifters are suspected, remove lifters and inspect. See Inspect Lifters (Page 4-33).
  - a. Clean lifter bore of all foreign material.
5. Inspect pushrod, lifter and lifter bore for improper fit and unusual wear.
6. Visually inspect camshaft lobes for abnormal wear.
7. Check top end components.
  - a. Check for excess rocker arm end play or binding.
  - b. Inspect valve stems for scuffing. Check stem to guide clearance.
  - c. Check for loose valve seats or signs of shifting.
8. Grind valves and valve seats. See Valve and Seat Repair (Page 4-39).

## DIAGNOSE SMOKING ENGINE OR HIGH OIL CONSUMPTION

### Initial Tests

1. Perform compression test and cylinder leakage test. See Compression Test (Page 4-12) and Cylinder Leakdown Test (Page 4-12).

### Check Before Cylinder Head Removal

1. Oil level too high
2. Oil carryover
3. Restricted breather hose
4. Restricted oil filter

### Check After Cylinder Head Removal

1. Clogged oil return passages
2. Valve guide seals
3. Valve guide to valve stem clearance
4. Gasket surfaces of head and cylinder

5. Cylinder head casting porosity allowing oil to drain into combustion chamber
6. O-ring damaged or missing from oil pump/crankcase junction
7. If above checks do not reveal cause:
  - a. Remove cylinder.
  - b. Verify piston ring gaps are properly staggered
  - c. Inspect for excess piston ring wear.

## REMOVE

### Removal

*NOTE*

*Pry overlap to release crimp clamps. If clamps must be cut, use a sharp high-quality wire cutter. To prevent breaking plastic fittings, do not twist clamp while cutting.*

1. See Figure 4-10. Push tip of small screwdriver under end of tang (2).

2. *NOTE*

*Plastic fittings are fragile. Use care when removing clamp.*

Pry until tang is free of tab (1).

3. Remove clamp.

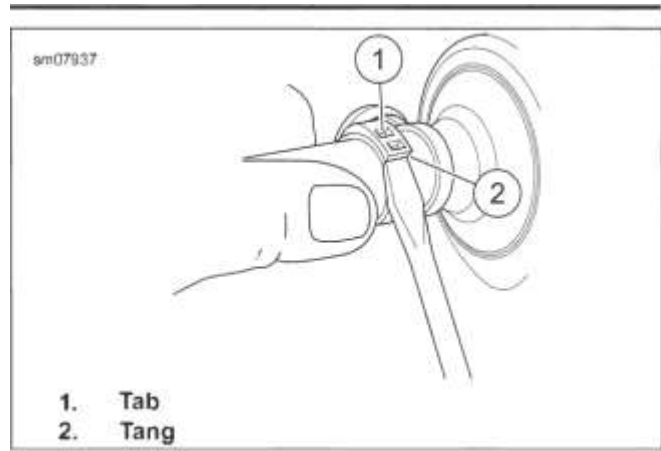


Figure 4-10. Removing Crimp Clamp

### INSTALL

| PART NUMBER | TOOL NAME         |
|-------------|-------------------|
| HD-41137    | HOSE CLAMP PLIERS |

### Installation

1. Install **new** clamp.
2. Tighten clamp using hose clamp pliers.

Special Tool: HOSE CLAMP PLIERS (HD-41137)

## PREPARE

1. Remove main fuse. See POWER DISCONNECT (Page 8-8).
2. Remove lower engine guard. See ENGINE GUARD (Page 3-118).

## REMOVE

### Downtube Assembly with Components

1. Remove oil cooler cover.
  - a. Pull forward at bottom to free posts from grommets.
  - b. Rotate up and lift off upper retainer.
2. Remove and discard clamp (5). See CRIMP CLAMPS (Page 4-16).
3. Remove spring clamp at top of downtube.
4. See Figure 4-11. Disconnect hoses from oil cooler (4) and upper end of downtube (1).
5. Remove screws (2, 3).
6. Pull assembly away from frame and disconnect voltage regulator connectors.
7. Remove downtube assembly with components.

## INSTALL

| FASTENER                      | TORQUE VALUE  |               |
|-------------------------------|---------------|---------------|
| Coolant downtube lower screws | 20-22 ft-lbs  | 27.1-29.8 N-m |
| Coolant downtube upper screws | 90-110 in-lbs | 10.2-12.4 N-m |

| PART NUMBER | CONSUMABLE  |
|-------------|---|
| 99642-97    | LOCTITE 243 MEDIUM STRENGTH THREADLOCKER AND SEALANT (BLUE) |

### Install Downtube Assembly

1. Apply silicone-based dielectric grease to both voltage regulator connectors.
2. Install new clamp (5) on hose.
3. See Figure 4-11. Install downtube assembly.
  - a. Connect voltage regulator connectors as downtube assembly is moved into place.
  - b. Apply threadlocker to threads of screws (2, 3).

LOCTITE 243 MEDIUM STRENGTH  
THREADLOCKER AND SEALANT (BLUE) (99642-97)

- c. Install screws (2, 3).
- d. Tighten screws (2).  
Torque: 90-110 in-lbs (10.2-12.4 N-m) *Coolant downtube upper screws*
- e. Install screws (3). Tighten.  
Torque: 20-22 ft-lbs (27.1-29.8 N-m) *Coolant downtube lower screws*
4. Connect hose to fitting (4).
  - a. Secure with hose clamp. See CRIMP CLAMPS (Page 4-16).
5. Connect downtube to forward oil hose with spring clamp.
6. Install oil cooler cover.
  - a. Engage upper retainer.
- b. Rotate down and back to engage posts to grommets.

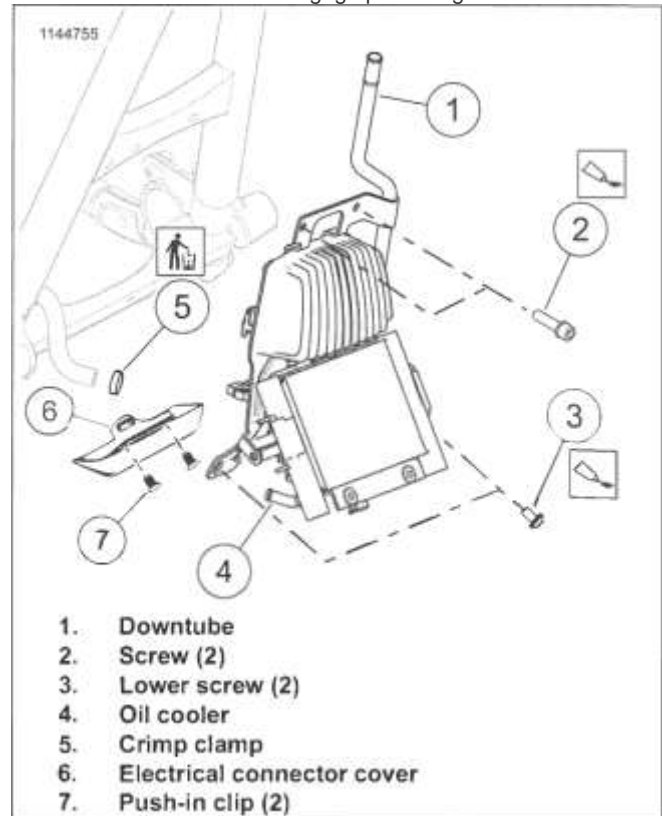


Figure 4-11. Oil Downtube Assembly

## DISASSEMBLE

1. Remove voltage regulator. See VOLTAGE REGULATOR (Page 8-14).
2. Remove grommets (9).



# OIL CHECK VALVE

3. See Figure 4-12. Remove hose (6).
  - a. Remove crimp clamps. See CRIMP CLAMPS (Page 4-16).
  - b. Remove hose.
4. Separate oil cooler from downtube.
  - a. Remove screws (2).
  - b. Disengage tab (5) from T-slot (3).

1. See Figure 4-12. Install oil cooler to downtube.
  - a. Engage tab (7) into T-slot (3).
  - b. Install two screws (1).
  - c. Tighten.  
Torque: 96-120 in-lbs (10.8-13.6 N-m) *Oil cooler screws*
2. Install hose (6).
  - a. Install hose between oil cooler (8) and downtube (4).
  - b. Secure with crimp clamps. CRIMP CLAMPS (Page 4-16)
3. Install grommets (9).

## ASSEMBLE

| FASTENER          | TORQUE VALUE  |               |
|-------------------|---------------|---------------|
| Oil cooler screws | 96-120 in-lbs | 10.8-13.6 N-m |

4. Install voltage regulator. See VOLTAGE REGULATOR (Page 8-14).

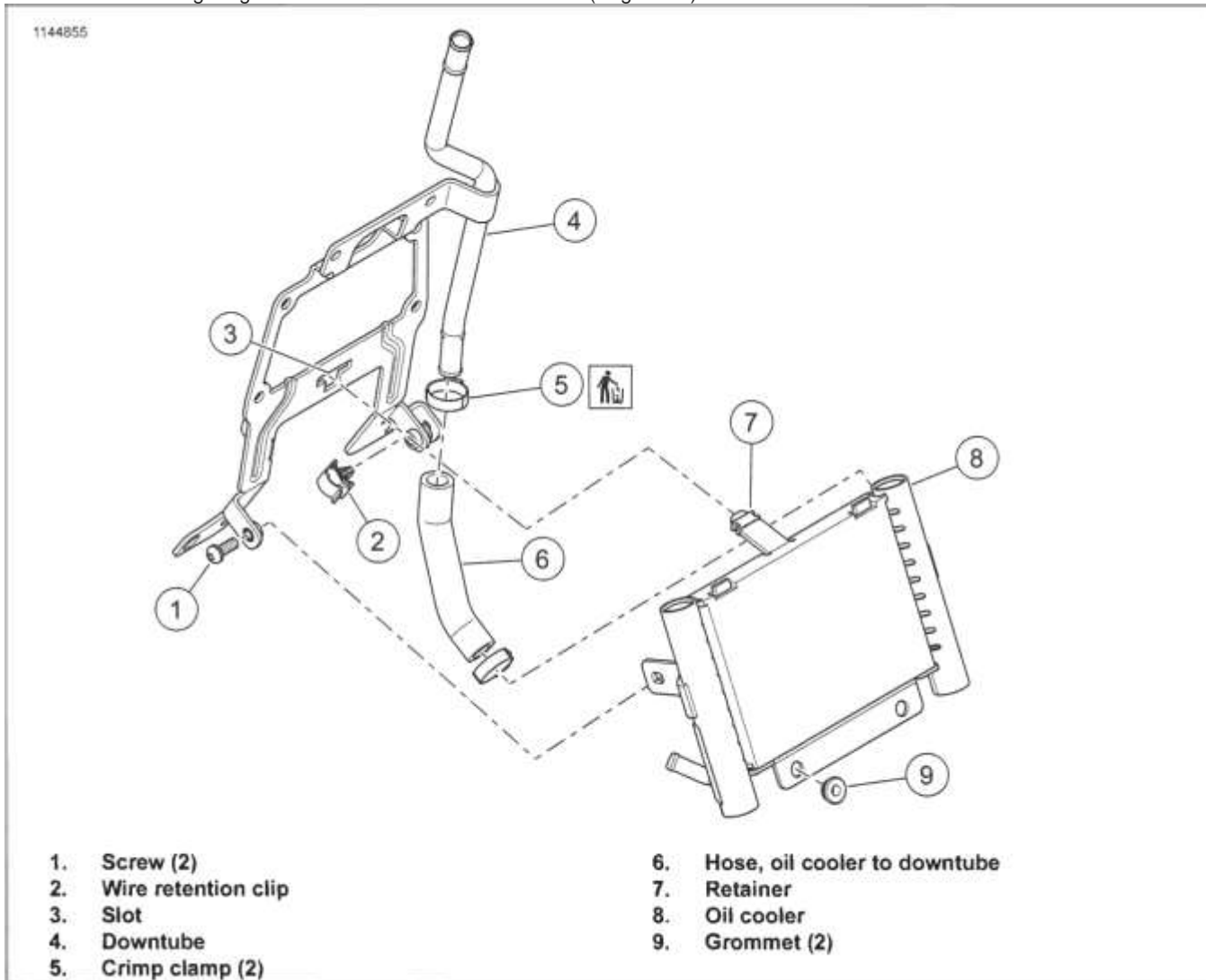


Figure 4-12. Oil Cooling Components

## COMPLETE

(Page 3-118).

1. Check engine oil level. See REPLACE ENGINE OIL AND FILTER (Page 2-9).
2. Install lower engine guard. See ENGINE GUARD (Page 3-118).
3. Install main fuse. See POWER DISCONNECT (Page 8-8).

## PREPARE

1. Remove main fuse. See POWER DISCONNECT (Page 8-8).

## REMOVE

1. See Figure 4-13. Disconnect hose from oil check valve (2) . See CRIMP CLAMPS (Page 4-16).
2. Remove oil check valve.
3. Discard O-ring (3).

## INSTALL

2. Install oil check valve (2) with O-ring. Tighten.

| FASTENER                                      | TORQUE VALUE |               |
|---|--------------|---------------|
| Crankcase oil check valve or plug with O-ring | 18-22 ft-lbs | 24.4-29.8 N-m |

1. See Figure 4-13. Lubricate **new** O-ring (3) with fresh oil.  
Torque: 18-22 ft-lbs (24.4-29.8 N-m) *Crankcase oil check valve or plug with O-ring*
3. Install lower hose.
  - a. Place **new** clamp on lower hose.

- b. Connect hose to check valve (2).

- c. Install clamp. See CRIMP CLAMPS (Page 4-16).

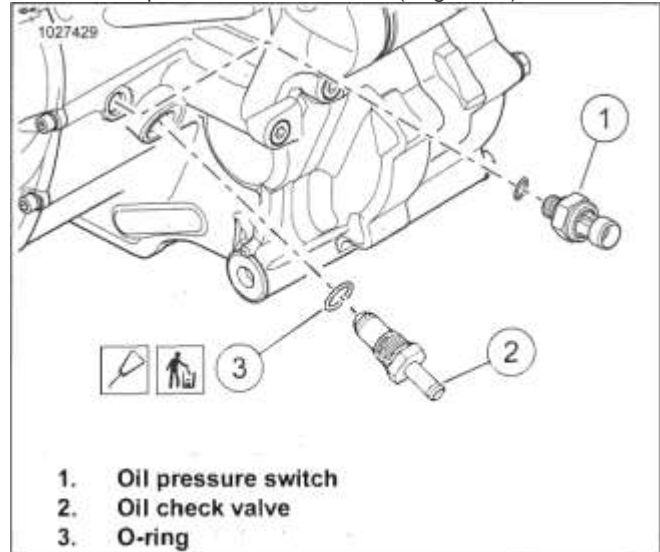


Figure 4-13. Oil Check Valve

## COMPLETE

1. Check engine oil level. See REPLACE ENGINE OIL AND FILTER (Page 2-9).
2. Install main fuse. See POWER DISCONNECT (Page 8-8).

**PREPARE**

1. Remove left and right side covers. See LEFT SIDE COVER (Page 3-62) and RIGHT SIDE COVER (Page 3-63).
2. Remove main fuse. See POWER DISCONNECT (Page 8-8).
3. Remove seat. See SEAT (Page 3-148).
4. Remove fuel tank. See FUEL TANK (Page 6-10).
5. Remove upper engine mount. See FRONT ENGINE MOUNT (Page 4-22).
6. Disconnect:
  - a. Fuel injector connectors. See FUEL INJECTORS (Page 6-25).
  - b. KS connectors. See KNOCK SENSOR (KS) (Page 8-97).
  - c. ACR connectors. See AUTOMATIC COMPRESSION RELEASE (ACR) (Page 8-98).
  - d. Left spark plug cables. See SPARK PLUG CABLES (Page 8-19)
  - e. Horn connectors. Release harness from clamp and cable strap. See HORN (Page 8-38).

**REMOVE** \_\_\_\_\_

| PART NUMBER | TOOL NAME         |
|-------------|-------------------|
| HD-41137    | HOSE CLAMP PLIERS |

1. **NOTE**  
Use clamp tool to reach rotated or difficult to reach spring clamps. HOSE CLAMP PLIERS (PART NUMBER: HD-41137)  
  
See Figure 4-14. Disconnect hose (6) from downtube.
2. Use low-pressure compressed air to blow oil out of line assembly.
  - a. Remove engine oil filler cap.
  - b. Blow into the hose (6) where disconnected from downtube.
3. Disconnect hose from transmission fitting (1).
4. Remove screws (7) from each manifold port (3).
5. Remove line assembly (5).
6. If necessary, remove rear oil hose (2) from line assembly (5).

**INSTALL**

| FASTENER                 | TORQUE VALUE  |               |
|--------------------------|---------------|---------------|
| Oil line manifold screws | 90-120 in-lbs | 10.2-13.6 N-m |

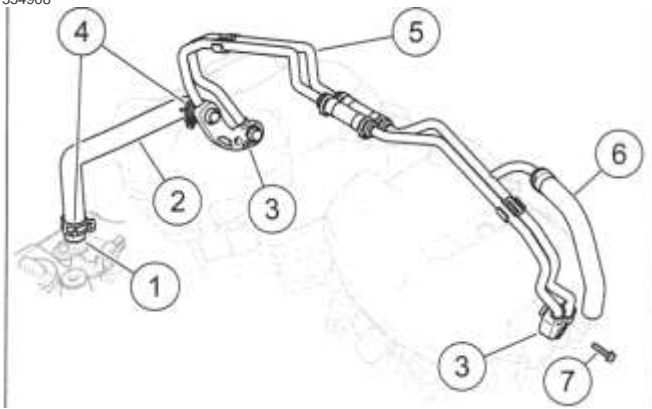
| PART NUMBER | CONSUMABLE  |
|-------------|---|
| 99642-97    | LOCTITE 243 MEDIUM STRENGTH THREADLOCKER AND SEALANT (BLUE) |

**NOTE**

Verify that all components and mating surfaces are free of all debris before assembling.

1. Clean components.
  - a. Remove all residual thread locking material from screws and manifolds.
  - b. Clean all debris from mating surfaces and threaded holes.
  - c. Clean all debris from coolant ports in heads and manifolds.
  - d. Thoroughly clean interior of all lines, especially if an engine failure occurred.
2. See Figure 4-14. If removed, install hose (2) to line assembly. Secure with spring clamp (4).
3. **NOTE**  
Make sure a-rings are not rolled after assembly.  
  
Install new O-rings on the ports of each manifold (3).
4. Install line assembly (5) with screws (7).
  - a. Apply threadlocker to threads of screws.  
LOCTITE 243 MEDIUM STRENGTH THREADLOCKER AND SEALANT (BLUE) (99642-97)
  - b. Tighten.  
Torque: 90-120 in-lbs (10.2-13.6 N-m) Oil line manifold screws
5. Install hose (2) to transmission fitting (1) with spring clamp (4).
6. Connect right spark plug cables.

354908



1. Transmission fitting
2. Rear oil hose
3. Manifold
4. Spring clamp (2)
5. Line assembly
6. Forward oil hose
7. Screw (4)

Figure 4-14. Oil Coolant Lines

**COMPLETE**

1. Connect:
  - a. Fuel injector connectors. FUEL INJECTORS (Page 6-25).
  - b. Knock sensor connectors. See KNOCK SENSOR (KS) (Page 8-97).
  - c. ACR connectors. See AUTOMATIC COMPRESSION RELEASE (ACR) (Page 8-98).
  - d. Left spark plug cables. See SPARK PLUG CABLES (Page 8-19).
  - e. Horn connectors. Secure harness in clamp and new cable strap. See HORN (Page 8-38).
2. Install stabilizer link and bracket. See FRONT ENGINE MOUNT (Page 4-22).
3. Install fuel tank. See FUEL TANK (Page 6-10).
4. Install seat. See SEAT (Page 3-148).
5. Install main fuse. See POWER DISCONNECT (Page 8-8).
6. Install side covers. See LEFT SIDE COVER (Page 3-62).
7. Check engine oil level. See REPLACE ENGINE OIL AND FILTER (Page 2-9).

## PREPARE

1. Remove right side rider footboard. See RIDER FOOTRESTS (Page 3-142).
2. Remove rear brake master cylinder and pedal. See REAR BRAKE MASTER CYLINDER (Page 3-42).
3. Remove voltage regulator. See VOLTAGE REGULATOR (Page 8-14).

## REMOVE AND INSTALL: LOWER FRONT ENGINE MOUNT

| FASTENER                                  | TORQUE VALUE |               |
|---|--------------|---------------|
| Engine mount, lower front, end cap screws | 42-48 ft-lbs | 56.9-65 N-m   |
| Engine mount, lower front, flange nut     | 50-55 ft-lbs | 67.8-74.6 N-m |

### Remove

1. Support engine with a jack under the crankcase. Use a wooden block to distribute pressure.
2. See Figure 4-15. Remove engine mount assembly.
  - a. Remove end cap fasteners (1).
  - b. Remove flange nut (5).
  - c. Remove engine mount bolt (2) with end cap (3).
3. Remove right engine mount (4).
4. Remove left engine mount (4).
  - a. Disconnect upper stabilizer link.
  - b. Raise engine. Hold engine toward right side of frame.
  - c. Remove left engine mount.

### Install

1. Disconnect stabilizer link. See Remove and Install: Upper Front Engine Mount in this section.
2. See Figure 4-15. Install left mount (4).
  - a. Hold engine toward right side of frame.
  - b. Install left engine mount.
  - c. Align notch in engine mount with tab on frame.
3. Install right engine mount (4).
  - a. Assemble engine mount bolt (2), end cap (3) and engine mount (4).
  - b. Align notch in engine mount with tab on end cap.

- c. Install assembly until engine mount bolt exits the left side.
- d. Verify the notches and tabs of engine mounts are aligned.
- e. Start fasteners (1).
- f. Install flange nut (5). Tighten.

Torque: 50-55 ft-lbs (67.8-74.6 N-m) *Engine mount, lower front, flange nut*

4. Tighten end cap fasteners (1).

Torque: 42-48 ft-lbs (56.9-65 N-m) *Engine mount, lower front, end cap screws*

5. ' Connect stabilizer link. See Remove and Install: Upper Front Engine Mount in this section.

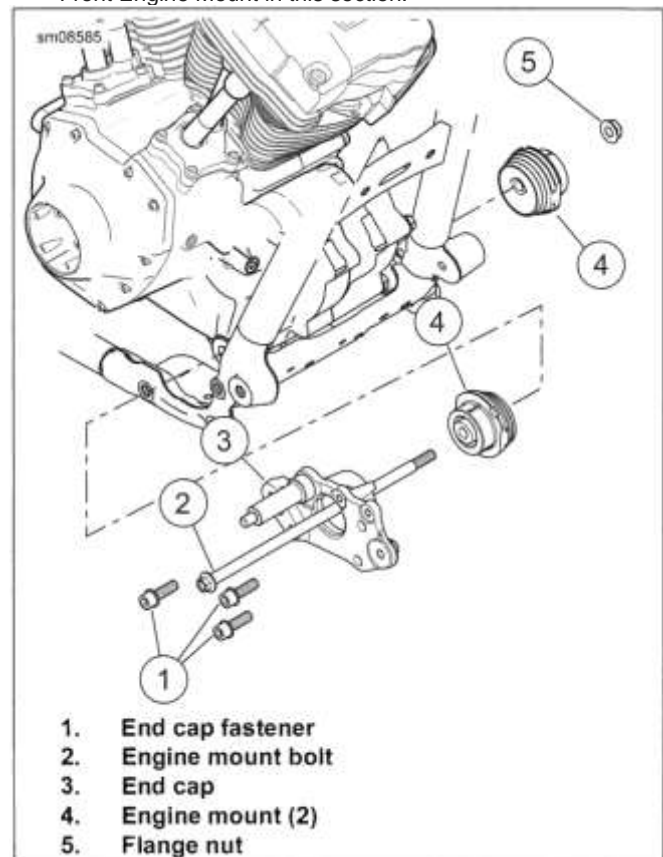


Figure 4-15. Front Engine Mount

## REMOVE AND INSTALL: UPPER FRONT ENGINE MOUNT

| FASTENER  | TORQUE VALUE      |               |
|---|-------------------|---------------|
| Engine mount, upper front, stabilizer link screws | 30.0--35.0 ft-lbs | 40.7-47.5 N-m |
| Engine stabilizer bracket screws                  | 45.0-50.0 ft-lbs  | 61-67.8 N-m   |

### Remove

1. See Figure 4-16. Remove screws (1,2) and washer (6).

- Remove stabilizer link (3).

### Inspect

- Check each end of the stabilizer link for excessive wear.
  - The spherical ball end may rotate freely, but should not have any lateral movement.
  - Replace the link if lateral movement exists.

### Install

- See Figure 4-16. Install washer (6).
- Install stabilizer link with screws (1, 2). Tighten.  
Torque: 30.0-35.0 ft-lbs (40.7-47.5 N-m) *Engine mount, upper front, stabilizer link screws*

### Stabilizer Link Bracket

- See Figure 4-16. Remove screws (5).
- Remove bracket (4).
- Install bracket (4).
- Install screws (5). Tighten.  
Torque: 45.0-50.0 ft-lbs (61-67.8 N-m) *Engine stabilizer bracket screws*

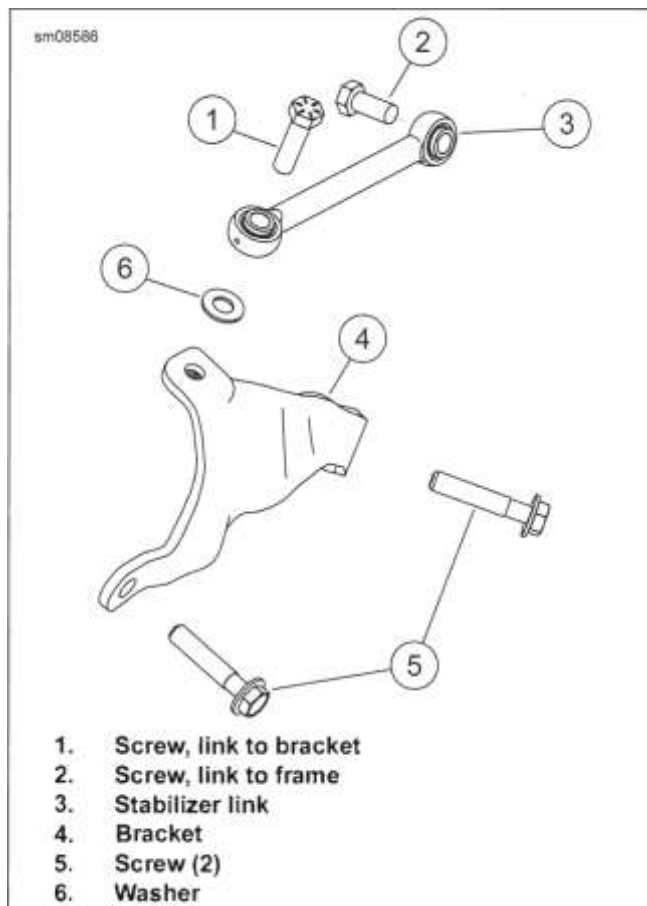


Figure 4-16. Engine Stabilizer

### COMPLETE

- Install voltage regulator. See VOLTAGE REGULATOR (Page 8-14).
- Install brake pedal and rear master cylinder. See REAR BRAKE MASTER CYLINDER (Page 3-42).
- Install right side rider footboard. See RIDER FOOTRESTS (Page 3-142).

## PREPARE

### NOTE

*Abrasive particles can damage machined surfaces or plug oil passageways. Clean parts before disassembly to prevent component damage.*

1. Use low-pressure compressed air to clean exterior surfaces of engine.
2. Remove seat. See SEAT (Page 3-148).
3. Disconnect negative battery cable. See POWER DISCONNECT (Page 8-8).
4. Remove fuel tank. See FUEL TANK (Page 6-10).
5. Remove mid-frame air deflectors, if equipped. See AIR DEFLECTORS (Page 3-119).
6. Disconnect spark plug cables from spark plugs. See SPARK PLUG CABLES (Page 8-19).
7. Disconnect ACR connectors. See AUTOMATIC COMPRESSION RELEASE (ACR) (Page 8-98).
8. Disconnect fuel injector connectors. See FUEL INJECTORS (Page 6-25).
9. Disconnect KS connectors. See KNOCK SENSOR (KS) (Page 8-97).
10. Disconnect horn connector. See HORN (Page 8-38).
11. Remove upper front engine mount. See FRONT ENGINE MOUNT (Page 4-22).
12. Remove upper cooling lines.
  - a. Twin-Cooled Engines: See COOLANT HOSES (Page 7-13).
  - b. Oil Cooled Engines: See OIL COOLANT LINES (Page 4-20).

## REMOVE

1. See Figure 4-17. Remove screws (3).
  - a. Secure stud (4) while removing center screw.
2. Remove upper rocker cover (2).
3. Discard gasket (1).
4. Clean threadlocker from threads and threaded Holes. See Cleaning (Page II).

## INSTALL

| FASTENER                    | TORQUE VALUE   |               |
|-----------------------------|----------------|---------------|
| Rocker cover, lower, stud   | 90-120 in-lbs  | 10.2-13.6 N-m |
| Rocker cover, upper, screws | 120-140 in-lbs | 13.6-15.8 N-m |

| PART NUMBER | CONSUMABLE  |
|-------------|---|
| 99642-97    | LOCTITE 243 MEDIUM STRENGTH THREADLOCKER AND SEALANT (BLUE) |

1. See Figure 4-17. Tighten stud (4).  
Torque: 90-120 in-lbs (10.2-13.6 N-m) *Rocker cover, lower, stud*
2. Install new gasket (1).
3. Install upper rocker cover (2).
  - a. Apply threadlocker to 5-7 screw threads.  
LOCTITE 243 MEDIUM STRENGTH THREADLOCKER AND SEALANT (BLUE) (99642-97)
  - b. Start all screws.
  - c. Secure stud (4) to prevent rotation when tightening center screw.
  - d. See Figure 4-18. Tighten in sequence shown.  
Torque: 120-140 in-lbs (13.6-15.8 N-m) *Rocker cover, upper, screws*

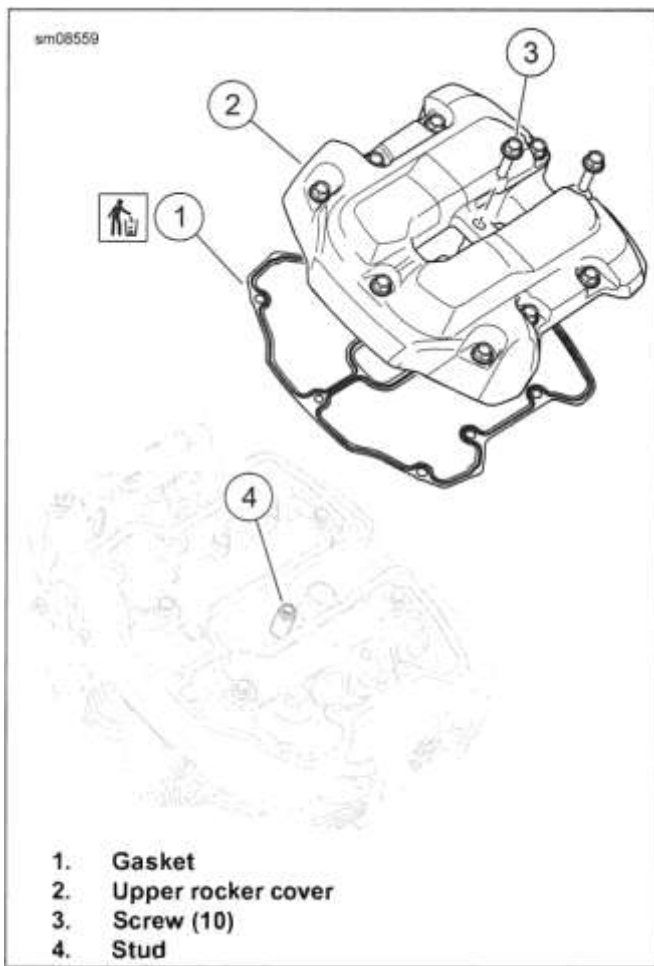


Figure 4-17. Rocker Cover Screws

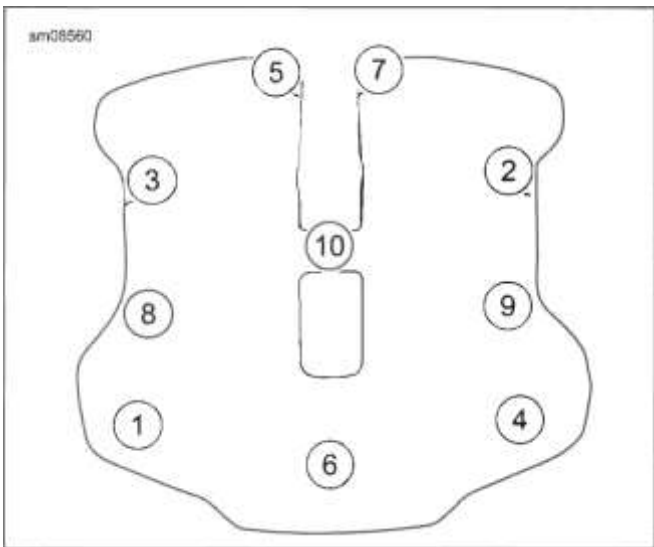


Figure 4-18. Rocker Cover Tightening Sequence

MOUNT (Page 4-22).

3. Connect horn connector. Secure harness. See HORN (Page 8-38).
4. Connect KS connectors. See KNOCK SENSOR (KS) (Page 8-97).
5. Connect fuel injector connectors. See FUEL INJECTORS (Page 6-25).
6. Connect ACR connectors. See AUTOMATIC COMPRESSION RELEASE (ACR) (Page 8-98).
7. Connect spark plug cables. See SPARK PLUG CABLES (Page 8-19).
8. Install mid-frame air deflectors, if equipped. See AIR DEFLECTORS (Page 3-119).
9. Install fuel tank. See FUEL TANK (Page 6-10).
10. Connect negative battery cable. See POWER DISCONNECT (Page 8-8).
11. Install seat. See SEAT (Page 3-148).

## **COMPLETE**

1. Install upper cooling lines.
  - a. **Twin-cooled engines:** See COOLANT HOSES (Page 7-13).
  - b. **Oil cooled engines:** See OIL COOLANT LINES (Page 4-20).
2. Install upper front engine mount. See FRONT ENGINE



## PREPARE

### NOTE

Abrasive particles can damage machined surfaces or plug oil passageways. Clean parts before disassembly to prevent component damage.

1. Use low-pressure compressed air to clean exterior surfaces of engine.
2. Remove seat. See SEAT (Page 3-148).
3. Disconnect negative battery cable. See POWER DISCONNECT (Page 8-8).
4. Remove fuel tank. See FUEL TANK (Page 6-10).
5. Remove mid-frame air deflectors, if equipped. See AIR DEFLECTORS (Page 3-119).
6. Disconnect spark plug cables from spark plugs. See SPARK PLUG CABLES (Page 8-19).
7. Disconnect ACR connectors. See AUTOMATIC COMPRESSION RELEASE (ACR) (Page 8-98).
8. Disconnect fuel injector connectors. See ■ FUEL INJECTORS (Page 6-25).
9. Disconnect KS connectors. See KNOCK SENSOR (KS) (Page 8-97).
10. Disconnect horn connector. See HORN (Page 8-38).
11. Remove upper front engine mount. See FRONT ENGINE MOUNT (Page 4-22).
12. Remove upper cooling lines.
  - a. **Twin-Cooled Engines:** See COOLANT HOSES (Page 7-13).
  - b. **Oil Cooled Engines:** See OIL COOLANT LINES (Page 4-20).
13. Remove upper rocker covers. See UPPER ROCKER COVERS (Page 4-24).

## REMOVE

1. See Figure 4-19. Remove screw (1).
2. Remove breather (2).
3. See Figure 4-20. Discard O-ring.

## INSTALL

| FASTENER       | TORQUE VALUE  |               |
|----------------|---------------|---------------|
| Breather screw | 90-120 in-lbs | 10.2-13.6 N-m |

1. See Figure 4-20. Lubricate **new** O-ring.
2. Install **new** O-ring.
3. See Figure 4-19. Install breather (2).
4. Install screw (1). Tighten.

Torque: 90-120 **in-lbs** (10.2-13.6 N-m) *Breather screw*

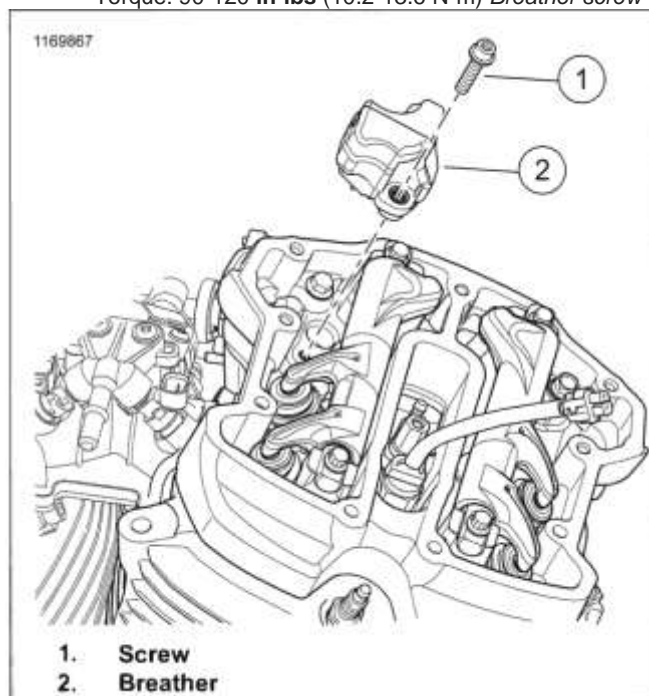


Figure 4-19. Breather

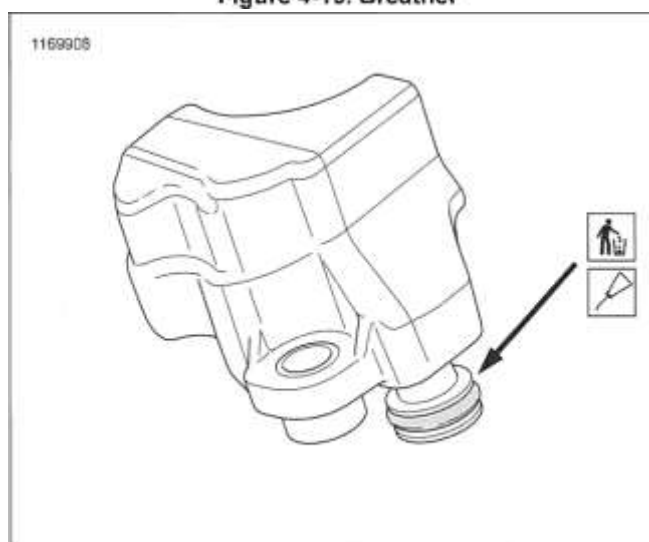


Figure 4-20. Breather O-ring

## COMPLETE

1. Install upper rocker covers. See UPPER ROCKER COVERS (Page 4-24).

- |   |     |
|---|-----|
| 2. Install upper cooling lines.   | 6.  |
| a. <b>Twin-cooled engines:</b> See COOLANT HOSES<br>(Page 7-13).            | 7.  |
| b. <b>Oil cooled engines:</b> See OIL COOLANT LINES<br>(Page 4-20).         | 8.  |
| 3. Install upper front engine mount. See FRONT ENGINE<br>MOUNT (Page 4-22). | 9.  |
| 4. Connect horn connector. Secure harness. See HORN<br>(Page 8-38).         | 10. |
| 5. Connect KS connectors. See KNOCK SENSOR (KS)<br>(Page 8-97).             | n   |
|   | 12. |

Connect fuel injector connectors. See FUEL INJECTORS (Page 6-25).

Connect ACR connectors. See AUTOMATIC COMPRESSION RELEASE (ACR) (Page 8-98).

Connect spark plug cables. See SPARK PLUG CABLES (Page 8-19).

Install mid-frame air deflectors, if equipped. See AIR DEFLECTORS (Page 3-119).

Install fuel tank. See FUEL TANK (Page 6-10).

Connect negative battery cable. See POWER DISCONNECT (Page 8-8).

Install seat. See SEAT (Page 3-148).

## PREPARE

**NOTE**

Abrasive particles can damage machined surfaces or plug oil passageways. Clean parts before disassembly to prevent component damage.

1. Use low-pressure compressed air to clean exterior surfaces of engine.
2. Remove seat. See SEAT (Page 3-148).
3. Disconnect negative battery cable. See POWER DISCONNECT (Page 8-8).
4. Remove fuel tank. See FUEL TANK (Page 6-10).
5. Remove mid-frame air deflectors, if equipped. See AIR DEFLECTORS (Page 3-119).
6. Disconnect spark plug cables from spark plugs. See SPARK PLUG CABLES (Page 8-19).
7. Disconnect ACR connectors. See AUTOMATIC COMPRESSION RELEASE (ACR) (Page 8-98).
8. Disconnect fuel injector connectors. See FUEL INJECTORS (Page 6-25).
9. Disconnect KS connectors. See KNOCK SENSOR (KS) (Page 8-97).
10. Disconnect horn connector. See HORN (Page 8-38).
11. Remove upper front engine mount. See FRONT ENGINE MOUNT (Page 4-22).
12. Remove upper cooling lines.
  - a. Twin-Cooled Engines: See COOLANT HOSES (Page 7-13).
  - b. Oil Cooled Engines: See OIL COOLANT LINES (Page 4-20).
13. Remove upper rocker covers. See UPPER ROCKER COVERS (Page 4-24).
14. Remove breathers. See BREATHERS (Page 4-26).

## REMOVE

1. See Figure 4-21. Remove screws (3) and stud (4).

**NOTE**

Engine may need to be rotated to provide clearance.

Remove lower rocker cover (2).

3. Discard gasket (1).

## INSTALL

| FASTENER                    | TORQUE VALUE  |               |
|-----------------------------|---------------|---------------|
| Rocker cover, lower, screws | 90-120 in-lbs | 10.2-13.6 N-m |
| Rocker cover, lower, stud   | 90-120 in-lbs | 10.2-13.6 N-m |

| PART NUMBER | CONSUMABLE  |
|-------------|---|
| 99642-97    | LOCTITE 243 MEDIUM STRENGTH THREADLOCKER AND SEALANT (BLUE) |

1. See Figure 4-21. Install new gasket (1).
2. Install lower rocker cover (2).
3. Apply threadlocker to screws (3) and stud (4).  
Consumable: LOCTITE 243 MEDIUM STRENGTH THREADLOCKER AND SEALANT (BLUE) (99642-97)
4. Figure 4-22. Install screws (3) and stud (4). Tighten in sequence shown.  
Torque: 90-120 in-lbs (10.2-13.6 N-m) *Rocker cover, lower, screws*  
Torque: 90-120 in-lbs (10.2-13.6 N-m) *Rocker cover, lower, stud*

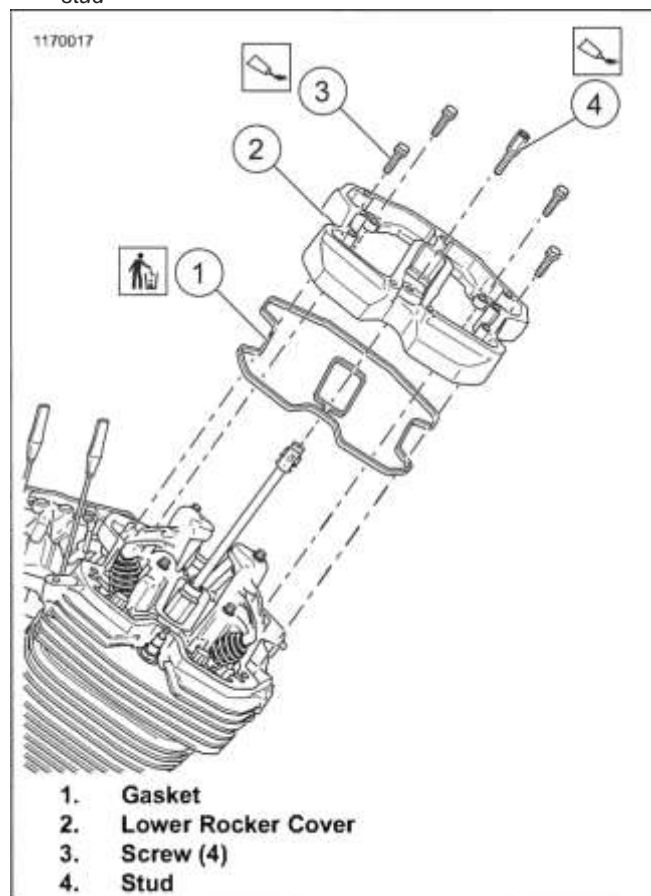


Figure 4-21. Lower Rocker Cover

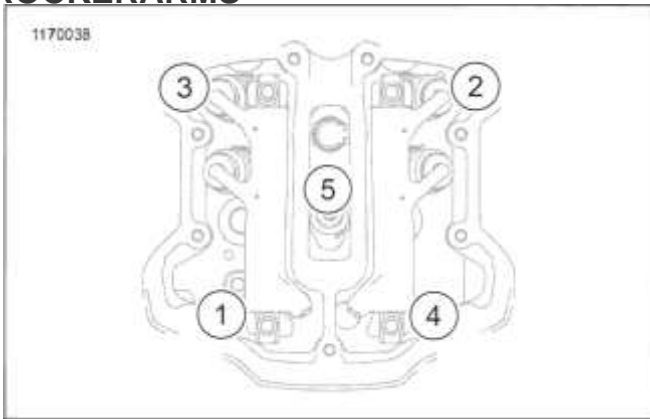


Figure 4-22. Lower Rocker Cover Torque Sequence

### COMPLETE

1. Install breathers. See BREATHERS (Page 4-26).
2. Install upper rocker covers. See UPPER ROCKER COVERS (Page 4-24).
3. Install upper cooling lines.
  - a. **Twin-cooled engines:** See COOLANT HOSES (Page 7-13).
  - b. **Oil cooled engines:** See OIL COOLANT LINES (Page 4-20).
4. Install upper front engine mount. See FRONT ENGINE MOUNT (Page 4-22).
5. Connect horn connector. Secure harness. See HORN (Page 8-38).
6. Connect KS connectors. See KNOCK SENSOR (KS) (Page 8-97).
7. Connect fuel injector connectors. See FUEL INJECTORS (Page 6-25).
8. Connect ACR connectors. See AUTOMATIC COMPRESSION RELEASE (ACR) (Page 8-98).
9. Connect spark plug cables. See SPARK PLUG CABLES (Page 8-19).
10. Install mid-frame air deflectors, if equipped. See AIR DEFLECTORS (Page 3-119).
11. Install fuel tank. See FUEL TANK (Page 6-10).
12. Connect negative battery cable. See POWER DISCONNECT (Page 8-8).
13. Install seat. See SEAT (Page 3-148).

## PREPARE

### NOTE

*Abrasive particles can damage machined surfaces or plug oil passageways. Clean parts before disassembly to prevent component damage.*

1. Use low-pressure compressed air to clean exterior surfaces of engine.
2. Remove seat. See SEAT (Page 3-148).
3. Disconnect negative battery cable. See POWER DISCONNECT (Page 8-8).
4. Remove fuel tank. See FUEL TANK (Page 6-10).
5. Remove mid-frame air deflectors, if equipped. See AIR DEFLECTORS (Page 3-119).
6. Disconnect spark plug cables from spark plugs. See SPARK PLUG CABLES (Page 8-19).
7. Disconnect ACR connectors. See AUTOMATIC COMPRESSION RELEASE (ACR) (Page 8-98).
8. Disconnect fuel injector connectors. See FUEL INJECTORS (Page 6-25).
9. Disconnect KS connectors. See KNOCK SENSOR (KS) (Page 8-97).
10. Disconnect horn connector. See HORN (Page 8-38).
11. Remove upper front engine mount. See FRONT ENGINE MOUNT (Page 4-22). ~
12. Remove upper cooling lines.
  - a. **Twin-Cooled Engines:** See COOLANT HOSES (Page 7-13).
  - b. **Oil Cooled Engines:** See OIL COOLANT LINES (Page 4-20).
13. Remove upper rocker covers. See UPPER ROCKER COVERS (Page 4-24).
14. Remove breathers. See BREATHERS (Page 4-26).
15. Remove lower rocker covers. See LOWER ROCKER COVERS (Page 4-28).

## REMOVE

1. Remove rocker arms.
  - a. Set piston at TDC on the compression stroke.

- b. See Figure 4-23. Alternately loosen screws (3) until screws can be turned by hand.
- c. Remove screws.
- d. Remove rocker shaft (1) and rocker arm (4).

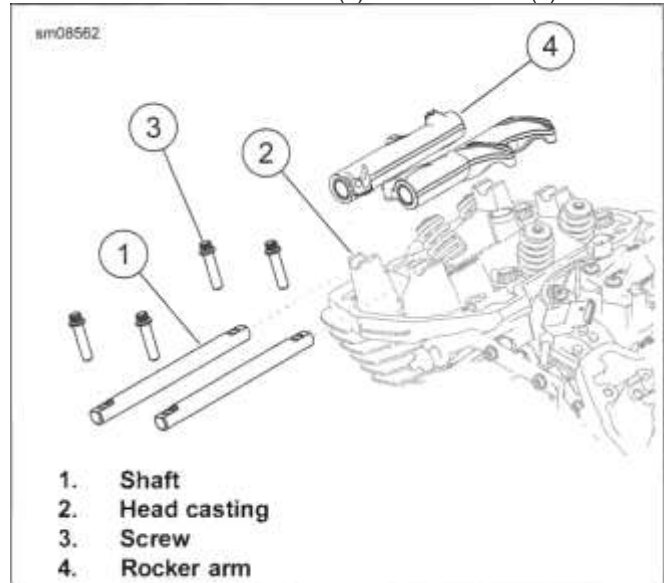


Figure 4-23. Remove Rocker Arms

## CLEAN AND INSPECT

1. Clean all parts.
2. Inspect for wear. Replace or repair as necessary.
  - a. Measure rocker arm bore.
  - b. Measure rocker arm shaft for excessive wear.
  - c. Inspect valve contact areas for excessive wear.
  - d. Inspect pushrod pocket for excessive wear.
  - e. Verify that oil holes in rocker arms are clean and open.

## INSTALL

| FASTENER           | TORQUE VALUE |               |
|--------------------|--------------|---------------|
| Rocker shaft screw | 23-27 ft-lbs | 31.2-36.6 N-m |

1. Set piston at approximate BDC of power stroke.
  2. Install rocker arms.
    - a. Verify lifters are on base circle of camshaft lobe.
    - b. See Figure 4-23. Install rocker arm (4) and rocker shaft (1).
    - c. Verify rocker shaft is seated in both towers.
    - d. Install screws (3).
    - e. Alternately tighten screws to pull rocker shaft down evenly.
- Torque: 23-27 ft-lbs (31.2-36.6 N-m) *Rocker shaft screw*

- f. Repeat with remaining rocker arms.

3. **NOTE**

*Do not rotate crankshaft until lifters have bled down. Rotating crankshaft sooner could result in valve-to-piston contact resulting in damage.*

Allow lifters to bleed down. When lifters have bled down, pushrods can be rotated by hand.

4. Check valve lash.
  - a. Position crankshaft at TDC of compression stroke. All valves will be closed.
  - b. While holding rocker arm against valves, attempt to slide a feeler gauge between each valve stem tip and the rocker arm.
  - c. A measurement in excess of maximum requires disassembly and repair of cylinder head assembly. Maximum allowable lash on a common rocker arm.
    0. 008 in (0.2 mm)

**COMPLETE**

---

1. Install lower rocker covers. See LOWER ROCKER COVERS (Page 4-28).
2. Install breathers. See BREATHERS (Page 4-26).
3. Install upper rocker covers. See UPPER ROCKER COVERS (Page 4-24).
4. Install upper cooling lines.
  - a. **Twin-cooled engines:** See COOLANT HOSES (Page 7-13).
  - b. **Oil cooled engines:** See OIL COOLANT LINES (Page 4-20).
5. Install upper front engine mount. See FRONT ENGINE MOUNT (Page 4-22).
6. Connect horn connector. Secure harness. See HORN (Page 8-38).
7. Connect KS connectors. See KNOCK SENSOR (KS) (Page 8-97).
8. Connect fuel injector connectors. See FUEL INJECTORS (Page 6-25).
9. Connect ACR connectors. See AUTOMATIC COMPRESSION RELEASE (ACR) (Page 8-98).
10. Connect spark plug cables. See SPARK PLUG CABLES (Page 8-19).
11. Install mid-frame air deflectors, if equipped. See AIR DEFLECTORS (Page 3-119).

12. Install fuel tank. See FUEL TANK (Page 6-10).
13. Connect negative battery cable. See POWER DISCONNECT (Page 8-8).
14. Install seat. See SEAT (Page 3-148).

**PREPARE**

*NOTE*

*Abrasive particles can damage machined surfaces or plug oil passageways. Clean parts before disassembly to prevent component damage.*

1. Use low-pressure compressed air to clean exterior surfaces of engine.
2. Remove seat. See SEAT (Page 3-148).
3. Disconnect negative battery cable. See POWER DISCONNECT (Page 8-8).
4. Remove fuel tank. See FUEL TANK (Page 6-10).
5. Remove air filter. See INSPECT AIR FILTER (Page 2-46).
6. Remove air filter backplate assembly. See AIR CLEANER BACKPLATE ASSEMBLY (Page 6-3).
7. Remove mid-frame air deflectors, if equipped. See AIR DEFLECTORS (Page 3-119).
8. Disconnect spark plug cables from spark plugs. See SPARK PLUG CABLES (Page 8-19).
9. Disconnect ACR connectors. See AUTOMATIC COMPRESSION RELEASE (ACR) (Page 8-98).
10. Disconnect fuel injector connectors. See FUEL INJECTORS (Page 6-25).
11. Disconnect KS connectors. See KNOCK SENSOR (KS) (Page 8-97).
12. Disconnect horn connector. See HORN (Page 8-38).
13. Remove upper front engine mount. See FRONT ENGINE MOUNT (Page 4-22).
14. Remove upper cooling lines.
  - a. **Twin-Cooled Engines:** See COOLANT HOSES (Page 7-13).
  - b. **Oil Cooled Engines:** See OIL COOLANT LINES (Page 4-20).
15. Remove upper rocker covers. See UPPER ROCKER COVERS (Page 4-24).
16. Remove rocker arms. See ROCKER ARMS (Page 4-30).

**REMOVE**

| PART NUMBER | TOOL NAME                               |
|-------------|---|
| 94086-09    | PUSHROD TUBE CLIP REMOVER AND INSTALLER |

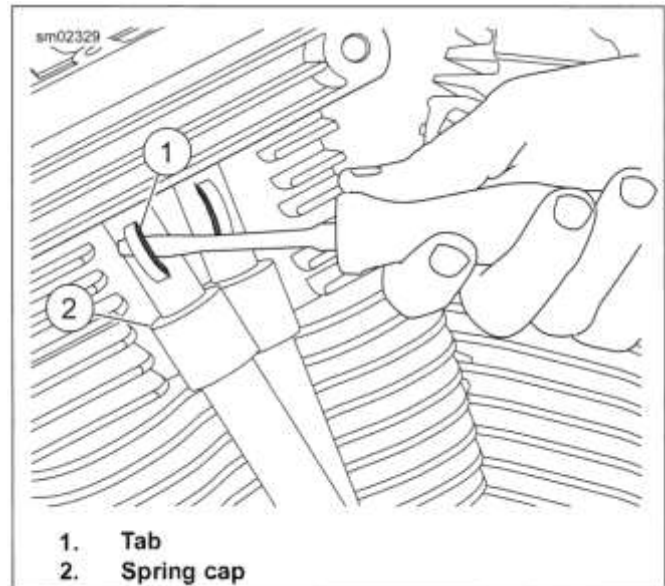
**Pushrods**

1. *NOTE*  
*Mark parts for location and orientation during removal.*

Remove pushrods.

**Pushrod Covers**

1. Remove pushrod covers.
  - a. See Figure 4-24. Insert the blade of a screwdriver in tab (1) of spring cap retainer.
  - b. While pushing down on spring cap (2) with special tool, rotate bottom of retainer outboard.  
  
Special Tool: PUSHROD TUBE CLIP REMOVER AND INSTALLER (94086-09)
2. Remove pushrod covers.
  - a. Collapse upper and lower pushrod covers.
3. Disassemble pushrod cover assemblies.
4. Discard O-rings.



**Figure 4-24. Removing Spring Cap Retainer**

**Lifters**

1. See Figure 4-25. Remove lifter covers. a.  
  
Remove four screws (1).

- b. Remove the lifter cover (2) and gasket (3). Discard gasket.

2. Remove lifters.

- a. Remove screw (4) securing anti-rotation device (5).
- b. Remove anti-rotation device.
- c. Remove the lifters (6) and place in clean plastic bags to prevent contamination.

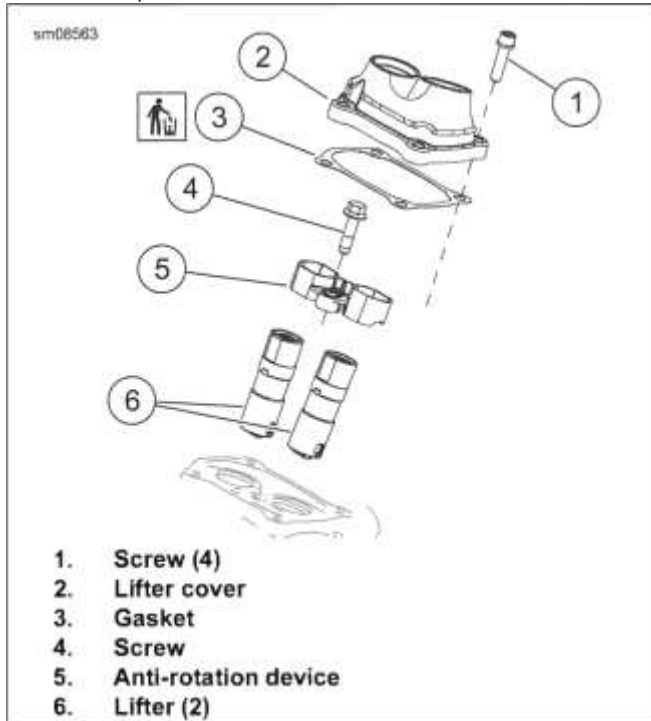


Figure 4-25. Lifter Cover

**CLEAN AND INSPECT**

1. Except for the hydraulic lifters, clean all parts in a non-volatile cleaning solution or solvent.

**A WARNING**

Compressed air can pierce the skin and flying debris from compressed air could cause serious eye injury. Wear safety glasses when working with compressed air. Never use your hand to check for air leaks or to determine air flow rates. (00061a)

2. Dry parts with low-pressure, compressed air.
3. Verify that O-ring seats and contact surfaces of pushrod covers are completely clean.
4. Verify that all oil holes are clean and open.
5. Replace any pushrods that are bent, dented, damaged, discolored, or have excessively worn or damaged ends.
6. Cover all parts to protect them from dust and dirt.

**INSPECT LIFTERS**

1. Measure lifter outer diameter. Record measurement.
2. Measure lifter bore. Subtract this measurement from recorded lifter measurement to determine clearance.
  - a. Clearance when **new**.
    0. 0009-0.0026 in (0.023-0.066 mm)
  - b. Install **new** lifters and/or replace crankcases if clearance exceeds service wear limit.
    0. 006 in (0.152 mm)
3. Check lifter roller end clearance.
  - a. Allowable end clearance.
    0. 008-0.022 in (0.203-0.559 mm)
  - b. Replace lifters if end clearance exceeds service wear limit.
    0. 022 in (0.559 mm)
4. Soak lifters in clean engine oil. Keep covered until assembly.
5. Examine lifter rollers. If damaged, examine the associated cam lobe.
  - a. Verify hydraulic lifter rollers turn freely.
  - b. Check for flat spots, scuff marks and pitting.
  - c. See Figure 4-26. A dull lifter roller surface is called frosting (2). Frosting is a cosmetic condition and does not affect function.
6. Inspect lifter for signs of wear.
  - a. Verify plunger is fully extended against C-clip.
  - b. Pump plunger to verify operation.

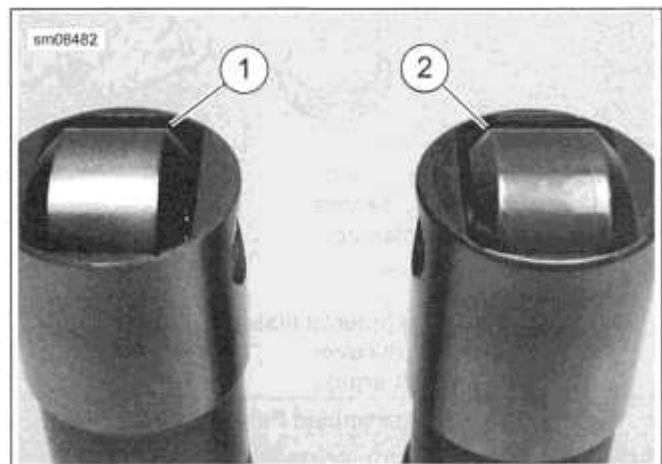


Figure 4-26. Roller Inspection



## ASSEMBLE PUSHROD COVER

1. See Figure 4-27. Apply clean engine oil to **new** O-rings (1,6 and 8).
2. Install upper O-ring (1) on upper pushrod cover (2).
3. Slide spring cap (4) and spring (5) onto body of upper pushrod cover. Move parts up until spring cap contacts upper O-ring seat.
4. Install middle O-ring (6) into groove on top of lower pushrod cover (7).
5. Apply clean engine oil on upper pushrod cover.
6. Slide straight end of upper pushrod cover into top end of lower pushrod cover.
7. Wipe pushrod covers clean.
8. Install lower O-ring (8) on lower pushrod cover.

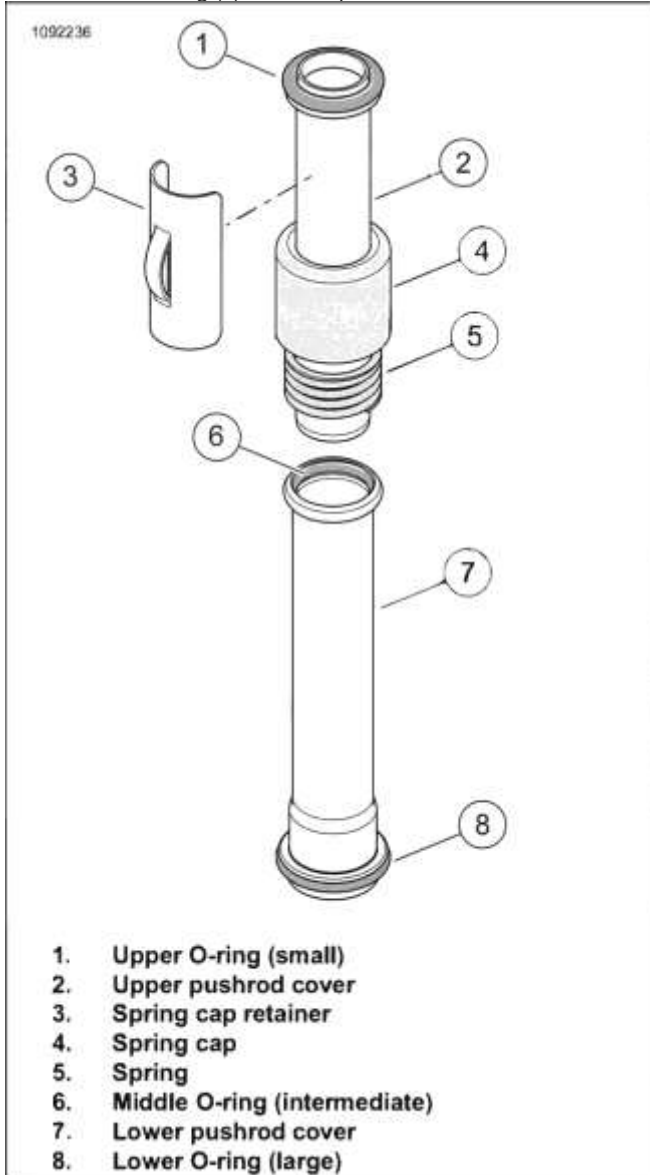


Figure 4-27. Assembled Pushrod Cover

## INSTALL

| PART NUMBER | TOOL NAME                               |
|-------------|---|
| 94086-09    | PUSHROD TUBE CLIP REMOVER AND INSTALLER |

| FASTENER                          | TORQUE VALUE   |               |
|-----------------------------------|----------------|---------------|
| Lifter anti-rotation device screw | 90-120 in-lbs  | 10.2-13.6 N-m |
| Lifter cover screws               | 132-156 in-lbs | 14.9-17.6 N-m |

| PART NUMBER | CONSUMABLE                    |
|-------------|-------------------------------|
| 11300002    | SCREAMIN' EAGLE ASSEMBLY LUBE |

## Lifters

### NOTE

Anti-rotation devices are marked "F" (front) and "R" (rear).

1. Install lifters.
  - a. Apply assembly lube to outer surface of each lifter. Pour a small amount onto each cam lobe.

### SCREAMIN' EAGLE ASSEMBLY LUBE (11300002)

- b. Rotate crankshaft until both cam lobes are visible in lifter bores.
- c. Carefully install lifters in lifter bores. **Do not** drop lifters onto cam lobes.
- d. See Figure 4-25. Install anti-rotation device.
- e. Install screw (4). Tighten.

Torque: 90-120 **in-lbs** (10.2-13.6 N-m) *Lifter anti-rotation device screw*

2. Install lifter cover (2), **new** gasket (3) and screws (1). Tighten in a cross-wise pattern.

Torque: 132-156 **in-lbs** (14.9-17.6 N-m) *Lifter cover screws*

## Pushrod Covers

1. Install pushrod covers.
  - a. Assemble pushrod covers with **new** O-rings.
  - b. Install **new** O-rings on each end of the pushrod cover.
  - c. Compress pushrod cover assembly and fit into lifter cover bore.
  - d. Extend assembly into cylinder head bore.
  - e. Verify that ends of pushrod cover fit snugly into cylinder head and lifter cover bores.
2. Install spring cap retainers.
  - a. Insert upper edge of spring cap retainer into cylinder head bore.
  - b. See Figure 4-28. Insert blade of small screwdriver between bottom edge of spring cap retainer and top of spring cap.
  - c. Press spring cap down with special tool and slide bottom edge of retainer toward tip of screwdriver.

Special Tool: PUSHROD TUBE CLIP REMOVER AND INSTALLER (94086-09)

- d. Verify that spring cap retainer seats tightly against upper pushrod cover.



Figure 4-28. Install Spring Cap Retainers

### Pushrods

1. Apply assembly lube to pushrod ends.

Consumable: SCREAMIN' EAGLE ASSEMBLY LUBE (11300002)

2.

#### NOTE

*If installing original pushrods, install in original location and orientation. Use 10.301 inch long (light blue stripes) as intake and 10.531 inch long (yellow stripes) as exhaust.*

Install pushrods.

### COMPLETE

2. Install upper rocker covers. See UPPER ROCKER COVERS
1. Install rocker arms. See ROCKER ARMS (Page 4-30).

(Page 4-24).

3. Install upper cooling lines.
- a. **Twin-cooled engines:** See COOLANT HOSES (Page 7-13).
- b. **Oil cooled engines:** See OIL COOLANT LINES (Page 4-20).
4. Install upper front engine mount. See FRONT ENGINE MOUNT (Page 4-22).
5. Connect horn connector. Secure harness. See HORN (Page 8-38).
6. Connect KS connectors. See KNOCK SENSOR (KS) (Page 8-97).
7. Connect fuel injector connectors. See FUEL INJECTORS (Page 6-25).
8. Connect ACR connectors. See AUTOMATIC COMPRESSION RELEASE (ACR) (Page 8-98).
9. Connect spark plug cables. See SPARK PLUG CABLES (Page 8-19).
10. Install mid-frame air deflectors, if equipped. See AIR DEFLECTORS (Page 3-119).
11. Install air filter backplate assembly. See AIR CLEANER BACKPLATE ASSEMBLY (Page 6-3).
12. Install air filter and cover. See INSPECT AIR FILTER (Page 2-46).
13. Install fuel tank. See FUEL TANK (Page 6-10).
14. Connect negative battery cable. See POWER DISCONNECT (Page 8-8).
15. Install seat. See SEAT (Page 3-148).

## PREPARE

### NOTE

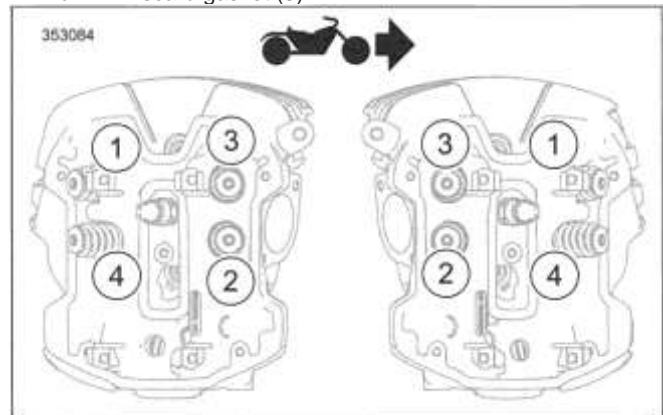
*Abrasive particles can damage machined surfaces or plug oil passageways. Clean parts before disassembly to prevent component damage.*

1. Use low-pressure compressed air to clean exterior surfaces of engine.
2. Remove seat. See SEAT (Page 3-148).
3. Disconnect negative battery cable. See POWER DISCONNECT (Page 8-8).
4. Remove fuel tank. See FUEL TANK (Page 6-10).
5. Remove air filter. See INSPECT AIR FILTER (Page 2-46).
6. Remove air filter backplate assembly. See AIR CLEANER BACKPLATE ASSEMBLY (Page 6-3).
7. Remove induction module. See INDUCTION MODULE (Page 6-26).
8. **Rear Cylinder:** Disconnect ET sensor. See ENGINE TEMPERATURE (ET) SENSOR (Page 8-96).
9. Remove mid-frame air deflectors, if equipped. See AIR DEFLECTORS (Page 3-119).
10. Remove right rider footboard. See RIDER FOOTRESTS (Page 3-142).
11. Remove exhaust system. See EXHAUST SYSTEM (Page 6-34).
12. Disconnect spark plug cables from spark plugs. See SPARK PLUG CABLES (Page 8-19).
13. Disconnect ACR connectors. See AUTOMATIC COMPRESSION RELEASE (ACR) (Page 8-98).
14. Disconnect KS connectors. See KNOCK SENSOR (KS) (Page 8-97).
15. Disconnect horn and mounting bracket. See HORN (Page 8-38).
16. Remove upper front engine mount. See FRONT ENGINE MOUNT (Page 4-22). ~
17. Remove upper cooling lines.
  - a. **Twin-Cooled Engines:** See COOLANT HOSES (Page 7-13).
  - b. **Oil Cooled Engines:** See OIL COOLANT LINES (Page 4-20).

18. Remove upper rocker covers. See UPPER ROCKER COVERS (Page 4-24).
19. Remove breathers. See BREATHERS (Page 4-26).
20. Remove lower rocker covers. See LOWER ROCKER COVERS (Page 4-28).
21. Remove rocker arms. See ROCKER ARMS (Page 4-30).
22. Remove pushrods. See PUSHRODS, LIFTERS AND COVERS (Page 4-32).

## REMOVE

1. See Figure 4-29. Discard cylinder head bolts.
  - a. Loosen each cylinder head bolt in sequence shown.
  - b. Discard head bolts.
2. See Figure 4-30. Remove cylinder head.
  - a. Lift cylinder head (2) from dowel pins.
  - b. Discard gasket (3).



**Figure 4-29. Head Bolt Tightening Sequence**

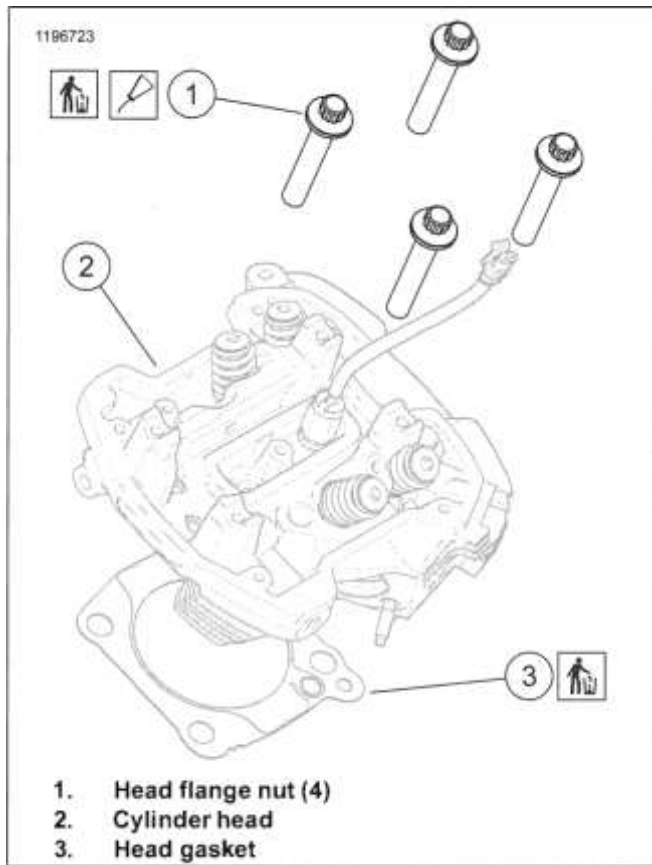


Figure 4-30. Cylinder Head

**CLEAN**

**NOTE**

Avoid getting debris in coolant and oil passages during gasket removal and cleaning.

1. Remove old gasket material from cylinder head. Do not cause scratches or nicks.

**NOTE**

Bead blasting materials could enter threaded holes, adversely affecting fastener engagement and torque indication. Cover all threaded holes before bead blasting.

**NOTICE**

**Do not use glass or sand to bead blast surfaces exposed to engine oil. Blasting materials can lodge in pores of the casting. Heat expansion releases this material which can contaminate oil resulting in engine damage. (00534b)**

2. Remove all carbon deposits from combustion chamber and machined surfaces of cylinder head. Do not remove any metal.
3. Soften stubborn deposits by soaking cylinder head in a carbon and gum dissolving agent.
4. Repeat as necessary.
5. Thoroughly clean cylinder head, spring retainers, tapered keepers, valves and valve springs in a non-volatile cleaning solution or solvent.

6. Wash in hot soapy water.

**.. WARNING**

7. Flush all passages to remove debris. **Compressed air can pierce the skin and flying debris from compressed air could cause serious eye injury. Wear safety glasses when working with compressed air. Never use your hand to check for air leaks or to determine air flow rates. (00061a)**

8. Dry parts with low-pressure, compressed air.

9. **NOTE**

Cover exposed internal engine area to prevent contamination.

Clean threadlocker from all screws and threaded holes. See Cleaning Fastener Threads.

**INSTALL**

2. Thoroughly flush all passages to remove loose debris.
3. See Figure 4-30. Install cylinder head.

| FASTENER  | TORQUE VALUE |               |
|---|--------------|---------------|
| Cylinder head nut torque step 1.                                  | 20-30 ft-lbs | 27.1-40.7 N-m |
| Cylinder head nut torque step 2. Loosen one turn.                 | -360°        | -360°         |
| Cylinder head nut torque step 3.                                  | 9-11 ft-lbs  | 12.2-14.9 N-m |
| Cylinder head nut torque step 4.                                  | 25-27 ft-lbs | 33.9-36.6 N-m |
| Cylinder head nut torque step 5. Tighten additional degree value. | 8°           | 8°            |

1. Clean all gasket surfaces.

- a. Install **new** gasket

with part number facing up.

- b. Install cylinder head on dowel pins.

4. Install **new** cylinder head flange nuts.

- a. Apply **new** engine oil to flanges of cylinder head nuts.
- b. Install cylinder head nuts.

5. See Figure 4-29. Tighten head nuts in five stages following sequence shown.

- a. Tighten.

Torque: 20-30 ft-lbs (27.1-40.7 N-m) *Cylinder head nut torque step 1.*

- b. Loosen one full turn.

Torque: -360° (-360°) *Cylinder head nut torque step 2. Loosen one turn.*

- c. Tighten.  
Torque: 9-11 ft-lbs (12.2-14.9 N-m) *Cylinder head nut torque step 3.*
- d. Tighten.  
Torque: 25-27 ft-lbs (33.9-36.6 N-m) *Cylinder head nut torque step 4.*
- e. Tighten to final torque.  
Torque: 90° (90°) *Cylinder head nut torque step 5. Tighten additional degree value.*

## DISASSEMBLE

| PART NUMBER | TOOLNAME                      |
|-------------|-------------------------------|
| B-49312     | CYLINDER HEAD HOLDING FIXTURE |
| HD-34736-B  | VALVE SPRING COMPRESSOR       |

1. See Figure 4-33. Secure cylinder head for service.
  - a. Remove spark plugs.
  - b. Turn 10 mm end of fixture (1) into cylinder head (2) spark plug hole.  
Special Tool: CYLINDER HEAD HOLDING FIXTURE (B-49312)
  - c. Clamp tool in vise.
2. Remove ACR. See AUTOMATIC COMPRESSION RELEASE (ACR) (Page 8-98).
3. Remove KS. See KNOCK SENSOR (KS) (Page 8-97).
4. Remove ET sensor. See ENGINE TEMPERATURE (ET) SENSOR (Page 8-96).
5. See Figure 4-34. Remove valves.
  - a. Use valve spring compressor to compress valve spring.  
Special Tool: VALVE SPRING COMPRESSOR (HD-34736-B)
  - b. Remove tapered keepers (1).
  - c. Slowly release valve spring compression.
  - d. Remove spring retainer (2) and valve spring (3).
  - e. Remove valve (11).
6. Remove and discard valve stem seal assembly (4).
7. Identify components.
  - a. Mark valve head for location.
  - b. Place tapered keepers, valve spring and spring retainer in a plastic bag with identification.
8. Remove remaining valves and components.

## CLEAN AND INSPECT

| PART NUMBER | TOOL NAME        |
|-------------|------------------|
| B-45525     | VALVE GUIDE HONE |
| HD-34751    | CLEANING BRUSH   |

### Cylinder Head

1. Check all gasket sealing surfaces for scratches and nicks.
2. Check head flatness with feeler gauge.
  - a. Using a straightedge, check gasket surface for warpage.
  - b. Replace head if warpage exceeds specification.
    0. 006 in (0.152 mm)
3. Verify all passages are clean and open.

### Valve Guides

1. Inspect external surfaces for cracks.
2. Prepare valve guides for inspection.
  - a. Lightly hone bore.  
Special Tool: VALVE GUIDE HONE (B-45525)
  - b. Scrub bore.  
Special Tool: CLEANING BRUSH (HD-34751)
  - c. Polish valve stem with fine emery cloth or steel wool to remove carbon buildup.
3. Check valve stem to guide clearance. See Table 4-21.
  - a. Measure valve guide **inside** diameter.
  - b. Measure valve stem **outside** diameter.
  - c. If stem to guide clearance exceeds service limits, repeat measurements with a **new** valve to determine worn components.
  - d. If stem to guide clearance exceeds service limits with a **new** valve, replace cylinder head.

### Valves and Valve Seats

1. With valves removed, inspect sealing surface of valve face and valve seat.
  - a. Sealing surfaces must be smooth and even around entire contact area.
  - b. If sealing contact area is uneven or shows evidence of pitting, carbon tracking, or other indications of combustion gas leakage, recondition valve and seat, or replace cylinder head assembly. See Valve and Seat Repair (Page 4-39).
2. Inspect valve for burning, cracking, carbon tracking, or other indications of combustion gas leakage.

3. Inspect top of valve stem for pitting or uneven wear.
4. Remove burrs around valve stem keeper groove with a fine tooth file.
5. To determine if valve stem is excessively worn, see valve guide inspection.

### Valve Springs

1. Inspect springs for cracked or discolored coils.
2. Check for squareness.
3. Check free length. See Table 4-22.
4. Load test using a commercially available valve spring tester.

### Tapered Keepers

Install **new** keepers any time valves are installed.

### Valve Seats

1. Inspect seats for cracking, chipping or burning, carbon tracking, or other indications of combustion gas leakage.
2. Check seat wear by measuring valve stem protrusion. See Valve and Seat Repair (Page 4-39).
3. Replace cylinder head if seats are damaged or worn excessively.

## VALVE AND SEAT REPAIR

#### NOTE

- Verify correct valve stem to valve guide clearance before refacing. Refer to Table 4-32.<sup>9</sup>

<sup>9</sup> The correct finished angles are 45 degree valve face and 46 degree valve seat eliminating the need to lap.

- Finish valve seat to an even width of 0.040-0.062 in (1.016-1.575 mm).
- See Figure 4-31. Replace the valve if margin (5) is less than 0.0313 in (0.795 mm).
- Refurbish valves and seats in pairs. Valve stem protrusion of a pair operated by the same rocker arm must be equal. Verify that valve lash is within specification. See Install (Page 4-30).
- If valve stem protrusion exceeds 1.752 in (44.5 mm), replace the valve or cylinder head as necessary.

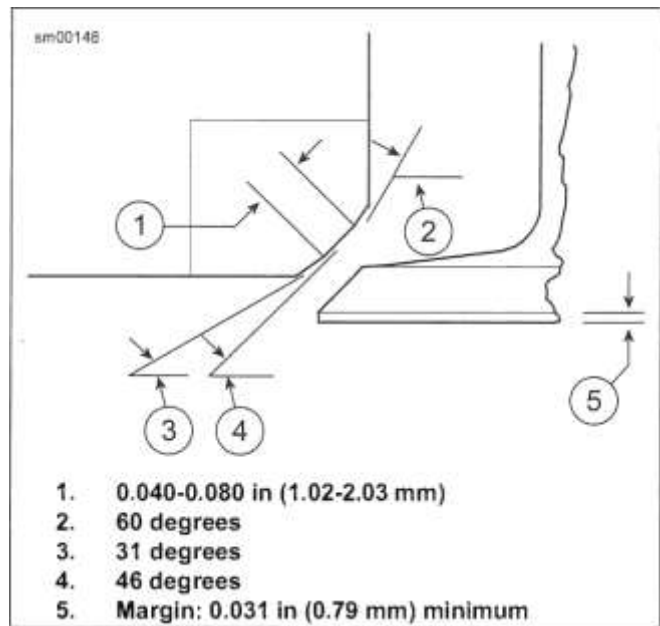


Figure 4-31. Valve and Seat Dimensions

Table 4-32. Valve Stem to Guide Clearance

| VALVE   | IN          | MM            |
|---------|-------------|---------------|
| Intake  | 0.001-0.003 | 0.0254-0.0762 |
| Exhaust | 0.001-0.003 | 0.0254-0.0762 |

| PART NUMBER | TOOLNAME                      |
|-------------|-------------------------------|
| B-49312     | CYLINDER HEAD HOLDING FIXTURE |
| HD-34736-B  | VALVE SPRING COMPRESSOR       |
| HD-34751    | CLEANING BRUSH                |
| HD-45322    | VALVE GUIDE SEAL INSTALLER    |

| PART NUMBER | CONSUMABLE                      |
|-------------|---------------------------------|
| 11300002    | j SCREAMIN' EAGLE ASSEMBLY LUBE |

1. See Figure 4-33. Secure cylinder head for service.

## ASSEMBLE

- a. Turn 10 mm end of head holding fixture into spark plug hole.  
Special Tool: CYLINDER HEAD HOLDING FIXTURE (B-49312)
- b. Clamp tool in vise.

#### NOTE

Install all parts in their original location.

2. See Figure 4-34. Install valve.

- a. Clean valve guide.  
Special Tool: CLEANING BRUSH (HD-34751)
- b. Generously apply assembly lube to valve stem.  
SCREAMIN' EAGLE ASSEMBLY LUBE (11300002)
- c. Install valve into cylinder head.
- d. Spin valve while installing to distribute lubricant.

- e. Remove valve and apply a second coat of SCREAMIN' EAGLE ASSEMBLY LUBE. Install valve.

3. See Figure 4-32. Install **new** valve stem seal.
  - a. Slide installer over valve stem tip.
 

Special Tool: VALVE GUIDE SEAL INSTALLER (HD-45322)
  - b. Generously apply assembly lube to installer.
 

SCREAMIN' EAGLE ASSEMBLY LUBE (11300002)
  - c. See Figure 4-32. Slide **new** valve stem seal assembly over installer and down valve stem until seated against cylinder head casting.
  - d. Remove installer from valve stem tip.

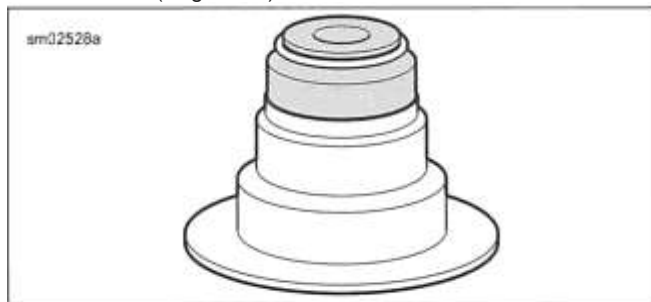
4. See Figure 4-34. Install valve spring.
  - a. Generously apply assembly lube to valve stem tip and keeper groove.
 

SCREAMIN' EAGLE ASSEMBLY LUBE (11300002)
  - b. Install valve spring (3) with smaller diameter coils topside.
  - c. Place spring retainer (2) on top of valve spring.

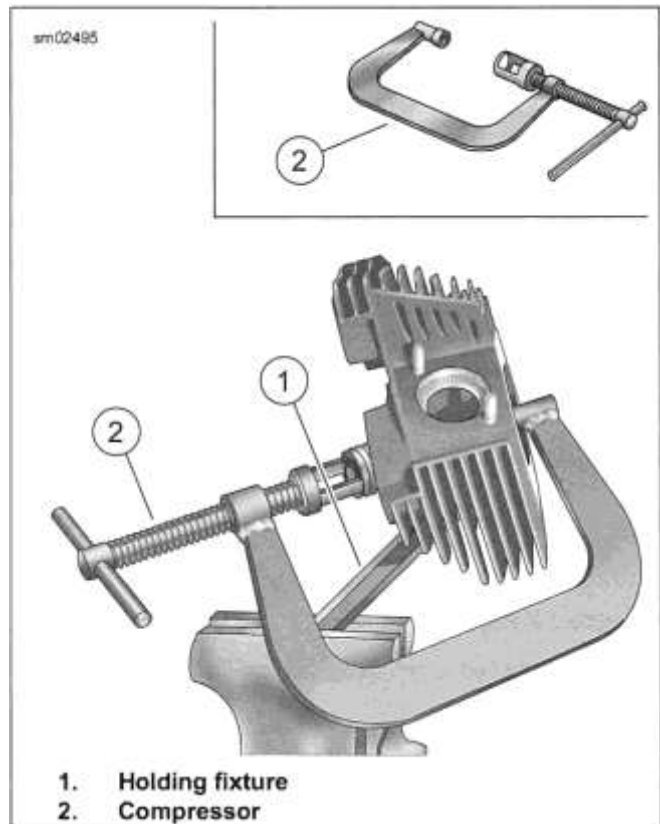
5. Install **new** keepers.
  - a. Compress valve spring.
 

Special Tool: VALVE SPRING COMPRESSOR (HD-34736-B)
  - b. Install keepers.
  - c. Slowly release valve spring compressor.
  - d. Tap end of valve stem twice with a soft mallet to make sure tapered keepers are tightly seated.

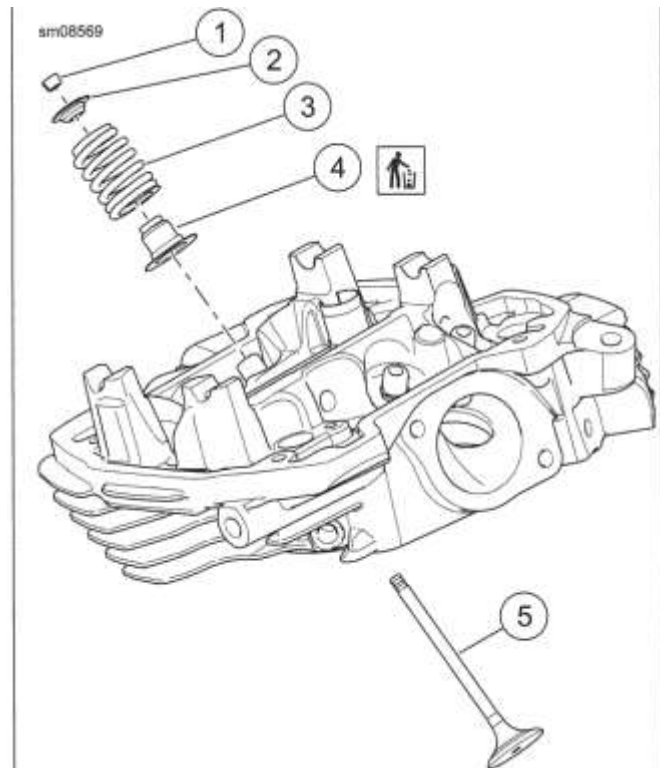
6. Install remaining valves.
7. Install KS. See KNOCK SENSOR (KS) (Page 8-97).
8. Install ACR. See AUTOMATIC COMPRESSION RELEASE (ACR) (Page 8-98).
9. Install ET sensor. See ENGINE TEMPERATURE (ET) SENSOR (Page 8-96).



**Figure 4-32. Valve Stem Seal Assembly**



**Figure 4-33. Valve Spring Compressor**



1. Keepers (2)
2. Retainer
3. Spring
4. Stem seal assembly
5. Valve

**Figure 4-34. Valve Components**



## **COMPLETE**

1. Install pushrods. See PUSHRODS, LIFTERS AND COVERS (Page 4-32).
2. Install rocker arms. See ROCKER ARMS (Page 4-30).
3. Install lower rocker covers. See LOWER ROCKER COVERS (Page 4-28).
4. Install breathers. See BREATHERS (Page 4-26).
5. Install upper rocker covers. See UPPER ROCKER COVERS (Page 4-24).
6. Install upper cooling lines.
  - a. **Twin-cooled engines:** See COOLANT HOSES (Page 7-13).
  - b. **Oil cooled engines:** See OIL COOLANT LINES (Page 4-20).
7. Install upper front engine mount. See FRONT ENGINE MOUNT (Page 4-22).
8. Connect horn and bracket. Secure harness. See HORN (Page 8-38).
9. Connect KS connectors. See KNOCK SENSOR (KS) (Page 8-97).
10. Connect ACR connectors. See AUTOMATIC COMPRESSION RELEASE (ACR) (Page 8-98).
11. Connect spark plug cables. See SPARK PLUG CABLES (Page 8-19).
12. Install exhaust system. See EXHAUST SYSTEM (Page 6-34).
13. Install rider right footboard. See RIDER FOOTRESTS (Page 3-142).
14. Install mid-frame air deflectors, if equipped. See AIR DEFLECTORS (Page 3-119).
15. Connect ET sensor. See ENGINE TEMPERATURE (ET) SENSOR (Page 8-96).
16. Install induction module. See INDUCTION MODULE (Page 6-26).
17. Install air filter backplate assembly. See AIR CLEANER BACKPLATE ASSEMBLY (Page 6-3).
18. Install air filter and cover. See INSPECT AIR FILTER (Page 2-46).
19. Install fuel tank. See FUEL TANK (Page 6-10).
20. Connect negative battery cable. See POWER DISCONNECT (Page 8-8).
21. Install seat. See SEAT (Page 3-148).

## PREPARE

### NOTE

*Abrasive particles can damage machined surfaces or plug oil passageways. Clean parts before disassembly to prevent component damage.*

1. Use low-pressure compressed air to clean exterior surfaces of engine.
2. Remove seat. See SEAT (Page 3-148).
3. Disconnect negative battery cable. See POWER DISCONNECT (Page 8-8).
4. Remove fuel tank. See FUEL TANK (Page 6-10).
5. Remove air filter. See INSPECT AIR FILTER (Page 2-46).
6. Remove air filter backplate assembly. See AIR CLEANER BACKPLATE ASSEMBLY (Page 6-3).
7. Remove induction module. See INDUCTION MODULE (Page 6-26).
8. **Rear Cylinder:** Disconnect ET sensor. See ENGINE TEMPERATURE (ET) SENSOR (Page 8-96).
9. Remove mid-frame air deflectors, if equipped. See AIR DEFLECTORS (Page 3-119).
10. Remove right rider footboard. See RIDER FOOTRESTS (Page 3-142).
11. Remove exhaust system. See EXHAUST SYSTEM (Page 6-34).
12. Disconnect spark plug cables from spark plugs. See SPARK PLUG CABLES (Page 8-19).
13. Disconnect ACR connectors. See AUTOMATIC COMPRESSION RELEASE (ACR) (Page 8-98).
14. Disconnect KS connectors. See KNOCK SENSOR (KS) (Page 8-97).
15. Disconnect horn and mounting bracket. See HORN (Page 8-38).
16. Remove upper front engine mount. See FRONT ENGINE MOUNT (Page 4-22).
17. Remove upper cooling lines.
  - a. **Twin-Cooled Engines:** See COOLANT HOSES (Page 7-13).
  - b. **Oil Cooled Engines:** See OIL COOLANT LINES (Page 4-20).

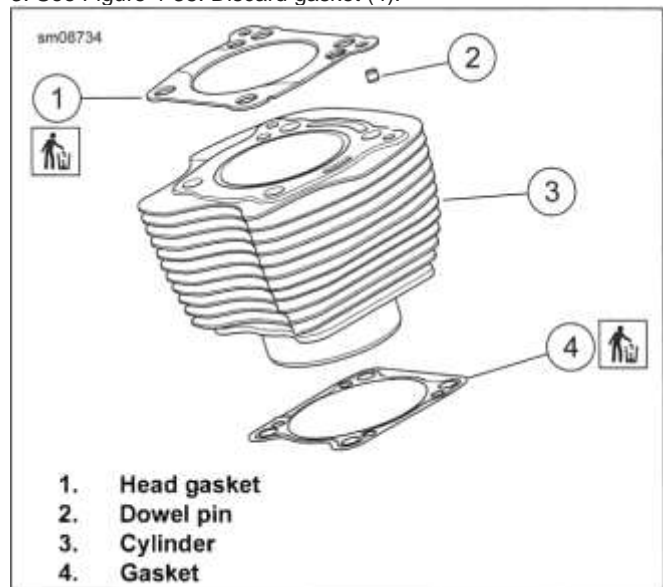
18. Remove upper rocker covers. See UPPER ROCKER COVERS (Page 4-24).
19. Remove breathers. See BREATHERS (Page 4-26).
20. Remove lower rocker covers. See LOWER ROCKER COVERS (Page 4-28).
21. Remove rocker arms. See ROCKER ARMS (Page 4-30).
22. Remove pushrods. See PUSHRODS, LIFTERS AND COVERS (Page 4-32).
23. Remove cylinder heads. See CYLINDER HEADS (Page 4-36).

## REMOVE

### NOTE

*Do not bend cylinder studs.*

1. Remove cylinder.
  - a. Raise cylinder and place clean shop towels under piston.
  - b. Hold piston to prevent touching studs as it exits cylinder.
  - c. Lift cylinder clear of piston.
2. Slide plastic tubing, rubber hose or conduit over each cylinder stud to protect cylinder studs and piston from damage.
3. See Figure 4-35. Discard gasket (4).



**Figure 4-35. Cylinder Assembly**

## INSTALL

| PART NUMBER  | TOOL NAME               |
|--------------|-------------------------|
| HD-52020     | CYLINDER HOLD-DOWN NUTS |
| HD-52185     | PISTON SUPPORT PLATE    |
| HD-96333-51F | PISTON RING COMPRESSOR  |

**NOTE**

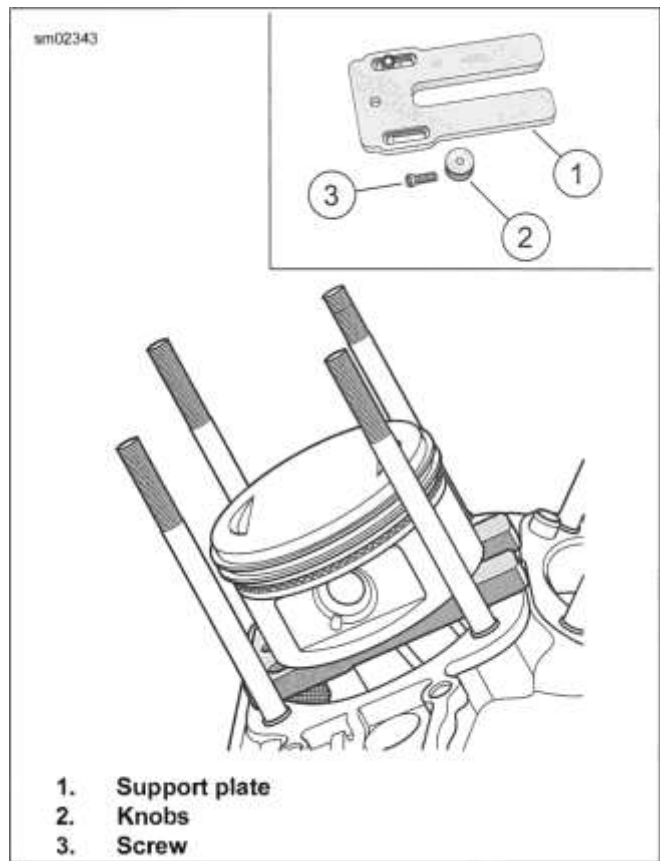
Front and rear cylinders are unique. Install in correct locations.

1. Prepare for cylinder installation.
  - a. Install **new** base gasket to crankcase.
  - b. See Figure 4-48. Verify piston ring alignment.
  - c. Apply clean engine oil to piston, piston rings and cylinder bore.
  - d. Rotate crankshaft until piston is at top dead center.
2. Remove protective covers from cylinder studs.
3. See Figure 4-36. Install support plate under piston. Special Tool: PISTON SUPPORT PLATE (HD-52185)
4. Rotate crankshaft until piston skirt is centered and firmly seated on top of support plate.
5. See Figure 4-37. Compress piston rings.

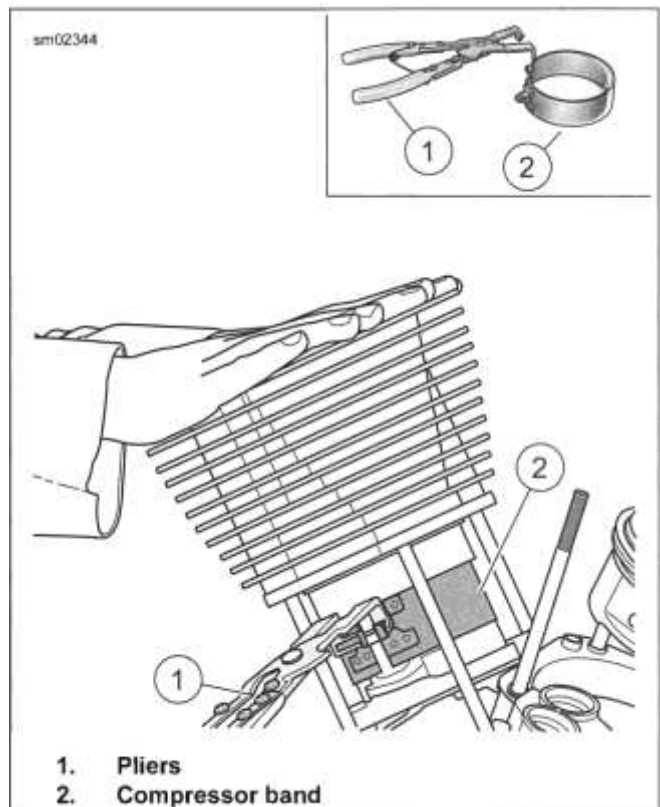
Special Tool: PISTON RING COMPRESSOR (HD-96333-51 F)

  - a. Align top of tool with center of piston ring land above top piston ring.
  - b. Compress piston rings.
6. Align cooling fin indents to right side of engine.
7. Slide cylinder over studs and piston until it rests on top of ring compressor.
8. Push down on cylinder with a sharp, quick motion using the palms of both hands.
9. Remove pliers and piston support plate.
10. Remove shop towels from around the crankcase bore.
11. Push down on the cylinder until it is fully seated in the crankcase bore.
12. See Figure 4-38. Install hold-down nuts onto cylinder studs.

Special Tool: CYLINDER HOLD-DOWN NUTS (HD-52020)



**Figure 4-36. Piston Support Plate**



**Figure 4-37. Piston Ring Compressor**

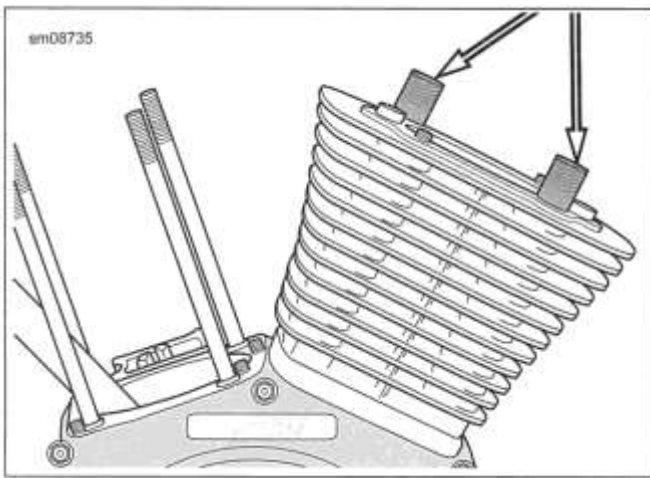


Figure 4-38. Install Threaded Cylinders to Studs

## CLEAN AND INSPECT

1. Clean all gasket material from cylinder.
2. Clean parts in a non-volatile cleaning solution. Dry parts with low-pressure, compressed air.
3. Inspect cylinder bore for defects or damage in ring travel area.
  - a. Light scratches less than piston travel length are considered normal. Hone pattern should travel through scratches. This cylinder is fit for operation.
  - b. Run a fingernail across scratches. If a scratch catches a fingernail, cylinder must be replaced.
  - c. Scoring or broad bands that are piston travel length, or evidence that material transferred between piston and cylinder, cylinder must be replaced.
4. Deglaze cylinders. See Deglaze Cylinder (Page 4-44).
5. Verify all oil holes are clean and open.
6. Remove any nicks or burrs from machined gasket surfaces.
7. Check gasket surfaces for flatness. Measure with a straightedge and feeler gauge.
  - a. Check cylinder-to-head gasket surface. Record measurements.
  - b. Check cylinder-to-lower gasket surface. Record measurements.
  - c. Discard cylinder if either gasket surface flatness is not within wear limits. See SPECIFICATIONS (Page 4-3)

## DEGLAZE CYLINDER

1. Lightly swab cylinder bore with a cloth dipped in clean engine oil.

### NOTE

*A precise 60 degree crosshatch pattern in the piston travel area is important.*

## NOTICE

The angular crosshatch pattern ensures an even flow of oil onto the cylinder walls and promotes longer cylinder, piston and ring life. An incorrect cross hatch pattern will result in insufficient oil retention and possible piston seizure and/or high oil consumption. (00536c)

2. Deglaze cylinder with a 240 grit flexible ball-type deglazing tool. Create a 60 degree crosshatch.

## NOTICE

Failure to remove all abrasive particles may result in premature cylinder, piston and ring wear and engine failure. (00537c)

3. Thoroughly wash cylinder bore with liquid dishwashing soap and hot water. Continue cleaning until a clean cloth shows no evidence of dirt or debris.
  - a. Hot rinse cylinder and dry with moisture free compressed air.
  - b. Immediately apply a thin film of clean engine oil to a clean white paper towel and thoroughly wipe inside of cylinder.
  - c. Repeat wiping process until a **new** towel remains white.

## COMPLETE

1. Install cylinder heads. See CYLINDER HEADS (Page 4-36).
2. Install pushrods. See PUSHRODS, LIFTERS AND COVERS (Page 4-32).
3. Install rocker arms. See ROCKER ARMS (Page 4-30).
4. Install lower rocker covers. See LOWER ROCKER COVERS (Page 4-28).
5. Install breathers. See BREATHERS (Page 4-26).
6. Install upper rocker covers. See UPPER ROCKER COVERS (Page 4-24).
7. Install upper cooling lines.
  - a. **Twin-cooled engines:** See COOLANT HOSES (Page 7-13).
  - b. **Oil cooled engines:** See OIL COOLANT LINES (Page 4-20).
8. Install upper front engine mount. See FRONT ENGINE MOUNT (Page 4-22).
9. Connect horn and bracket. Secure harness. See HORN (Page 8-38).

10. Connect KS connectors. See KNOCK SENSOR (KS) (Page 8-97).
11. Connect ACR connectors. See AUTOMATIC COMPRESSION RELEASE (ACR) (Page 8-98).
12. Connect spark plug cables. See SPARK PLUG CABLES (Page 8-19).
13. Install exhaust system. See EXHAUST SYSTEM (Page 6-34).
14. Install rider right footboard. See RIDER FOOTRESTS (Page 3-142).
15. Install mid-frame air deflectors, if equipped. See AIR DEFLECTORS (Page 3-119).
16. Connect ET sensor. See ENGINE TEMPERATURE (ET) SENSOR (Page 8-96).
17. Install induction module. See INDUCTION MODULE (Page 6-26).
18. Install air filter backplate assembly. See AIR CLEANER BACKPLATE ASSEMBLY (Page 6-3).
19. Install air filter and cover. See INSPECT AIR FILTER (Page 2-46).
20. Install fuel tank. See FUEL TANK (Page 6-10).
21. Connect negative battery cable. See POWER DISCONNECT (Page 8-8).
22. Install seat. See SEAT (Page 3-148).

**PREPARE**

*NOTE*

*Abrasive particles can damage machined surfaces or plug oil passageways. Clean parts before disassembly to prevent component damage.*

1. Use low-pressure compressed air to clean exterior surfaces of engine.
2. Remove seat. See SEAT (Page 3-148).
3. Disconnect negative battery cable. See POWER DISCONNECT (Page 8-8).
4. Remove fuel tank. See FUEL TANK (Page 6-10).
5. Remove air filter. See INSPECT AIR FILTER (Page 2-46).
6. Remove air filter backplate assembly. See AIR CLEANER BACKPLATE ASSEMBLY (Page 6-3).
7. Remove induction module. See INDUCTION MODULE (Page 6-26).
8. **Rear Cylinder:** Disconnect ET sensor. See ENGINE TEMPERATURE (ET) SENSOR (Page 8-96).
9. Remove mid-frame air deflectors, if equipped. See AIR DEFLECTORS (Page 3-119).
10. Remove right rider footboard. See RIDER FOOTRESTS (Page 3-142).
11. Remove exhaust system. See EXHAUST SYSTEM (Page 6-34).
12. Disconnect spark plug cables from spark plugs. See SPARK PLUG CABLES (Page 8-19).
13. Disconnect ACR connectors. See AUTOMATIC COMPRESSION RELEASE (ACR) (Page 8-98).
14. Disconnect KS connectors. See KNOCK SENSOR (KS) (Page 8-97).
15. Disconnect horn and mounting bracket. See HORN (Page 8-38).
16. Remove upper front engine mount. See FRONT ENGINE MOUNT (Page 4-22). ~
17. Remove upper cooling lines.
  - a. **Twin-Cooled Engines:** See COOLANT HOSES (Page 7-13).
  - b. **Oil Cooled Engines:** See OIL COOLANT LINES (Page 4-20).

18. Remove upper rocker covers. See UPPER ROCKER COVERS (Page 4-24).
19. Remove breathers. See BREATHERS (Page 4-26).
20. Remove lower rocker covers. See LOWER ROCKER COVERS (Page 4-28).
21. Remove rocker arms. See ROCKER ARMS (Page 4-30).
22. Remove pushrods. See PUSHRODS, LIFTERS AND COVERS (Page 4-32).
23. Remove cylinder heads. See CYLINDER HEADS (Page 4-36).
24. Remove cylinders. See CYLINDERS (Page 4-42).

**REMOVE**

| PART NUMBER | TOOLNAME                              |
|-------------|---------------------------------------|
| HD-42320-D  | PISTON PIN EXTRACTOR                  |
| HD-51069    | PISTON PIN CLIP REMOVER/INSTALLER KIT |

1. *NOTE*  
 It is not necessary to remove both piston pin retaining rings for piston removal.  
  
 Place clean shop towels over crankcase bore to prevent the piston pin retaining ring from falling into the crankcase.
2. See Figure 4-39. Remove and discard one piston pin retaining ring.  
 Special Tool: PISTON PIN CLIP REMOVER/INSTALLER KIT (HD-51069)
3. See Figure 4-40. Remove piston.
4. *NOTE*  
 Prevent connecting rod from striking crankcase.  
  
 Remove piston pin.  
 Special Tool: PISTON PIN EXTRACTOR (HD-42320-D)
5. Wrap connecting rod to prevent damage.
6. Mark piston location on piston underside.

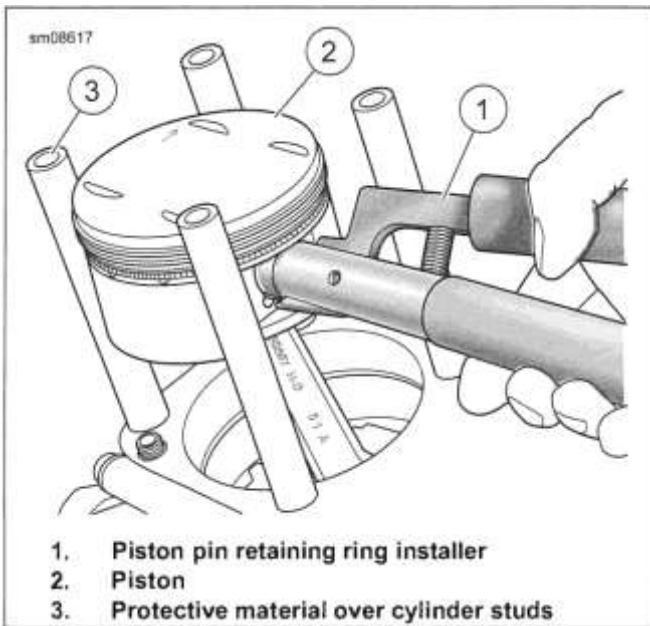


Figure 4-39. Piston Pin Retaining Ring Removal

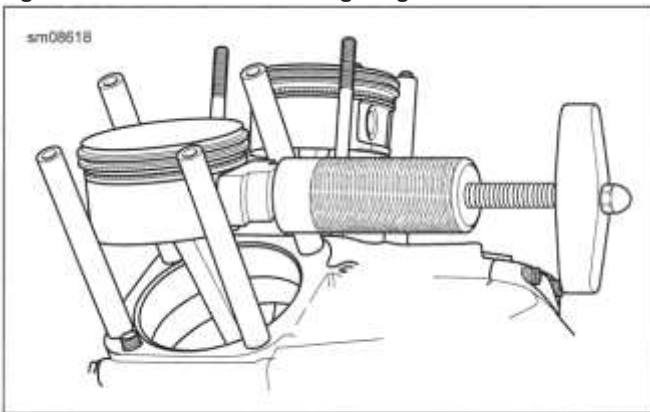


Figure 4-40. Remove Piston Pin

## INSTALL

| PART NUMBER | TOOL NAME                           |
|-------------|-------------------------------------|
| HD-51069-17 | NOSE ADAPTER                        |
| HD-51069-2  | PISTON PIN RETAINING RING INSTALLER |

| PART NUMBER | CONSUMABLE                    |
|-------------|-------------------------------|
| 11300002    | SCREAMIN' EAGLE ASSEMBLY LUBE |

### A WARNING

Failure to properly install and inspect piston pin retaining rings will result in engine failure and possible rear wheel lockup, which could result in death or serious injury. (03406a)

#### 1. *NOTE*

Do not reuse piston pin retaining rings.

See Figure 4-41. Install one **new** piston pin retaining ring.

Special Tool: PISTON PIN RETAINING RING INSTALLER (HD-51069-2)

Special Tool: NOSE ADAPTER (HD-51069-17)

- See Figure 4-43. Insert tool (2) into piston pin bore until claw is aligned with slot (3) in piston.

- See Figure 4-42. Verify retaining ring end gap (3) is opposite from opening (2).
- Verify retaining ring is fully seated in groove.

#### 2. Install piston.

- Apply assembly lube to piston pin, piston pin bores and upper connecting rod bore.

SCREAMIN' EAGLE ASSEMBLY LUBE (11300002)

- Remove protective wrap from connecting rod.
- See Figure 4-43. Place piston *over* rod end with arrow (1) pointing toward front of engine.
- Insert piston pin through piston and connecting rod until it contacts installed retaining ring.
- Cover crankcase openings.

#### 3. See Figure 4-41. Install **new** retaining ring.

Special Tool: PISTON PIN RETAINING RING INSTALLER (HD-51069-2)

Special Tool: NOSE ADAPTER (HD-51069-17)

- See Figure 4-42. Verify retaining ring end gap (3) is opposite from opening (2).
- Verify retaining ring is fully seated in groove.

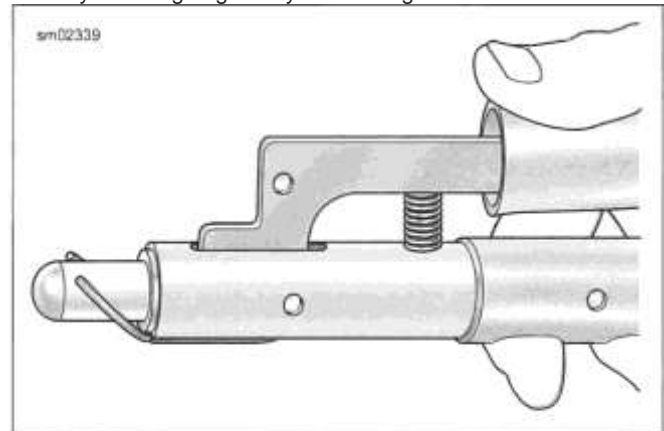
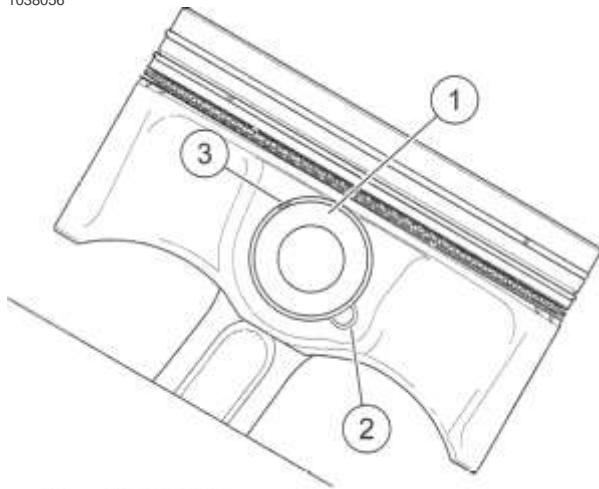
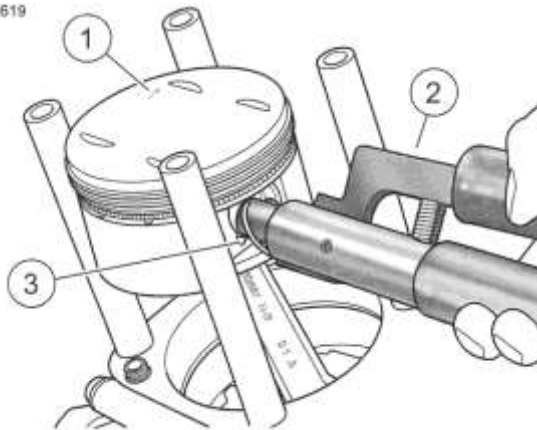


Figure 4-41. Aligning Retaining Ring



- 1. Piston pin
- 2. Retaining ring opening
- 3. End gap location

sm08619



- 1. Arrow
- 2. Piston pin retaining ring installer
- 3. Slot

Figure 4-43. Install Pin Retaining Ring

**DISASSEMBLE**

- 1. Remove piston rings.

**CLEAN AND INSPECT**

**Clean**

**A WARNING**

Compressed air can pierce the skin and flying debris from compressed air could cause serious eye injury. Wear safety glasses when working with compressed air. Never use your hand to check for air leaks or to determine air flow rates. (00061a)

- 1. *NOTE*
  - Do not sandblast or glass bead blast pistons. Bead blasting rounds off ring lands.
  - Do not damage or enlarge holes.
  - Do not use a wire brush to clean oil holes.

- Avoid scratching sides of the piston ring grooves.

Remove all combustion deposits.

- a. Soak pistons in hot water with dishwashing liquid or a cleaner designed to remove carbon and does not corrode aluminum.
  - b. Thoroughly rinse pistons.
  - c. Clean oil drain holes in oil control ring groove with a small bristle brush.
  - d. Dry parts with low-pressure, compressed air.
- 2. Verify that all oil holes are clean and open.

3. *NOTE*  
A portion of a compression ring properly ground to a sharp chisel-like edge works well to clean piston ring grooves.

Figure 4-42. Pre-Installed Retaining Ring deposits.

**Inspect**

- 1. Check piston running clearance.
  - a. Insert a lightly oiled good piston pin into piston pin bore to feel for proper fit. The pin should slide in and out without binding, pivoting or rocking.
  - b. Measure pin and pin bore diameters to determine running clearance. Replace piston and/or pin if clearance exceeds specified dimension.

0. 0008 in (0.02 mm)

2. *NOTE*  
Pistons with superficial wear marks, minor scratching or mild scoring are acceptable for use.

Carefully inspect pistons for damage or excessive wear. Discard if any following conditions are found:

- a. Using dye penetrant, inspect pistons for surface cracks. Particularly examine area around pin bores, ring lands and oil drain holes beneath piston crown.

*NOTE*

Thoroughly wash usable pistons to remove traces of dye.

- b. Cracked, worn or bent ring lands.
  - c. Cracks, gouges, deep scratches or heavy scoring.
  - d. Evidence of burning, etching or melting.
  - e. Marks or imprints caused by contact with valves.
- 3. Lightly file to remove any dings, nicks or burrs around edge of piston crown.



4. See Figure 4-44. Measure piston ring side clearance.

- a. Insert edge of a **new** ring into piston ring groove.
- b. Insert a feeler gauge between upper surface of ring and ring land.
- c. Repeat this check at several locations around piston.
- d. Discard piston if side clearance of either compression ring exceeds specified dimension.

0. 004 in (0.102 mm)

- e. Discard piston if oil control ring side clearance exceeds specified dimension.

0. 010 in (0.25 mm)

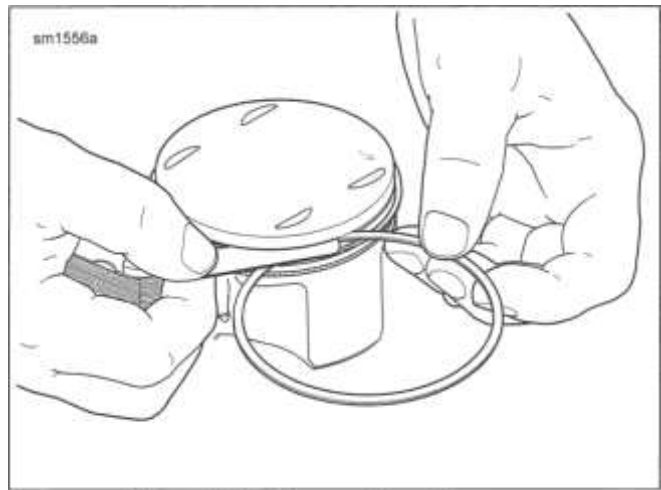


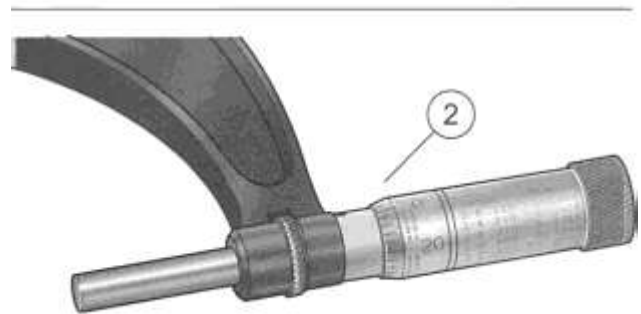
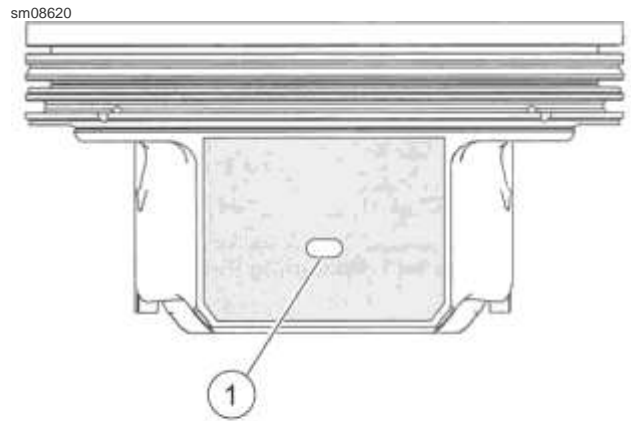
Figure 4-44. Measure Ring Clearance

5. **NOTE**

- Check piston clearance in the cylinder in which that piston will run. Cylinder must be deglazed. See *Deglaze Cylinder* in **CYLINDERS** (Page 4-42).
- This inspection is very heat-sensitive.
  - Both piston and cylinder must be at room temperature before proceeding.
  - Do not check piston running clearance immediately after honing or deglazing cylinder.
  - Even holding the piston for too long can cause measurements to vary by as much as Dimension:  
**0. 0002 in (0.0051 mm).**
- See upper frame of Figure 4-45. The coating has an oval-shaped opening (1) on each side of the piston for proper micrometer placement.
- See lower frame of Figure 4-45. Use a blade or ball anvil style micrometer to measure piston.

See Figure 4-45. Measure running clearance of pistons:

- a. Measure piston skirt at bare aluminum openings (1).
- b. Transfer measurement to dial bore gauge.
- c. Measure at top and middle of piston ring travel zone. Measure parallel and perpendicular to crankshaft.
- d. Replace piston and/or cylinder if running clearance exceeds service wear limit. See **SPECIFICATIONS** (Page 4-3).



1. Bare aluminum opening
2. Micrometer
3. Spherical anvil adapters

Figure 4-45. Measure Piston Running Clearance

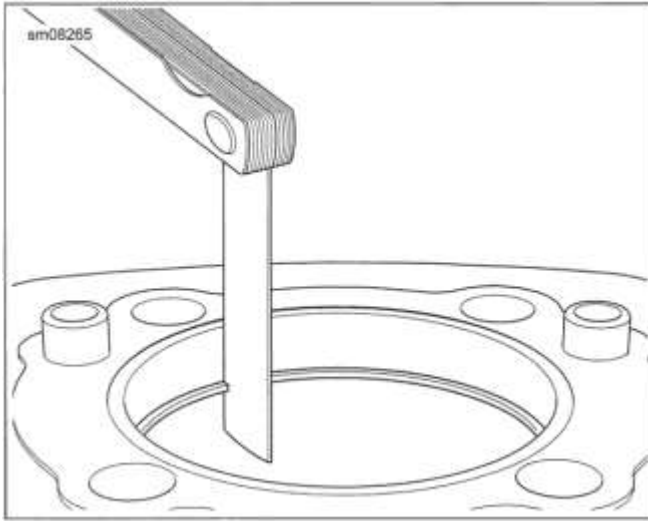
### CHECK PISTON RING GAP

1. **NOTE**

- Always install **new** piston rings.
- Always deglaze the cylinder before installing **new** rings.
- Insufficient ring gap may cause the ends to touch at operating temperatures. This causes ring breakage, cylinder scuffing and/or piston seizure.
- Excessive ring gap causes high oil consumption and blow-by of exhaust gases resulting in contaminated oil and reduced engine efficiency

See Figure 4-46. Check ring end gaps before installing on piston.

- a. Place ring in cylinder.
- b. Align piston ring in cylinder with upside down piston.
- c. Measure ring end gap with feeler gauge. Refer to Table 4-12.



**Figure 4-46. Measuring Ring Gap**

- 
1. **NOTE**  
*Piston ring position is identical for both pistons.*

See Figure 4-47. Install three-piece oil control ring.

- a. Install expander ring (1) with ends facing up (see inset).
- b. Install bottom oil rail (2).
- c. Install top oil rail (3).

2. **NOTE**
  - *Position "N" marking on compression rings up.*
  - 11 *Top ring face has chamfered corners. Second ring has a sharp upper corner and a groove cut around lower edge.*

Install second compression ring (4).

3. Install top compression ring (5).
4. Verify all piston rings rotate freely.
5. See Figure 4-48. Arrange gaps as shown.

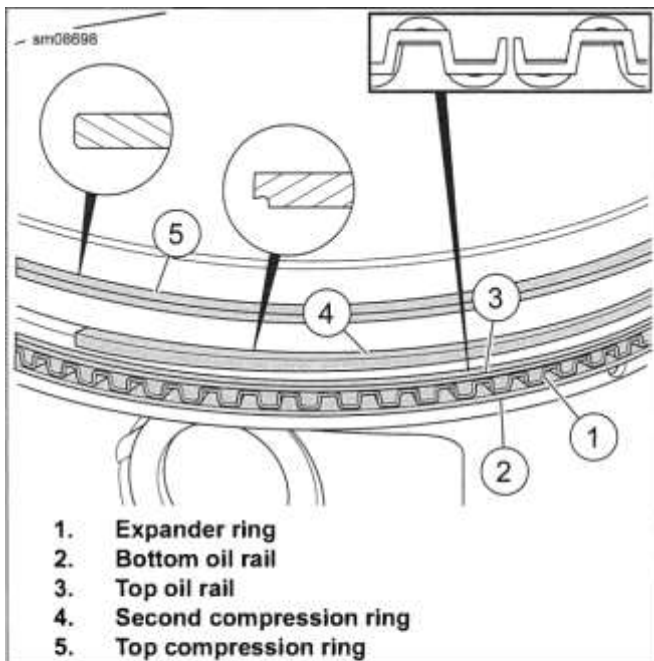


Figure 4-47. Piston Rings

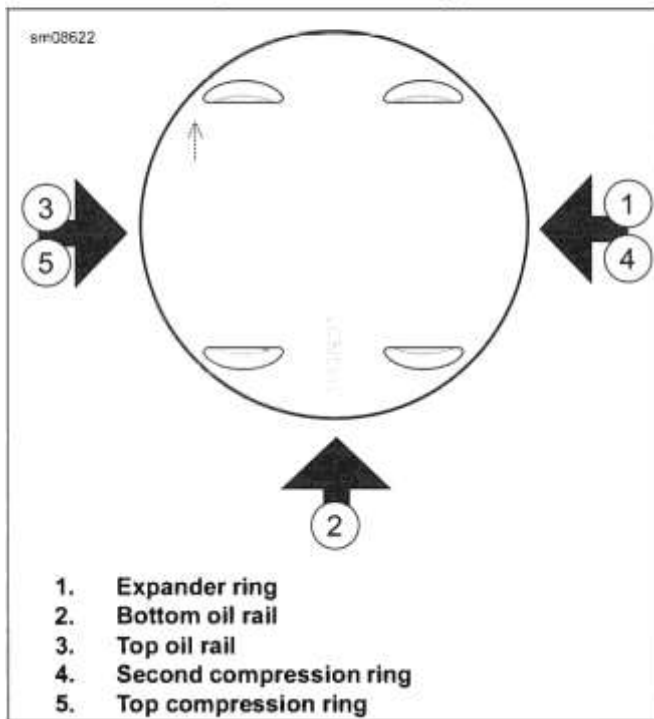


Figure 4-48. Piston Ring Order of Assembly and Gap Alignment

**COMPLETE** \_\_\_\_\_

1. Install cylinders. See CYLINDERS (Page 4-42).
2. Install cylinder heads. See CYLINDER HEADS (Page 4-36).
3. Install pushrods. See PUSHRODS, LIFTERS AND COVERS (Page 4-32).
4. Install rocker arms. See ROCKER ARMS (Page 4-30).
5. Install lower rocker covers. See LOWER ROCKER COVERS (Page 4-28).
6. Install breathers. See BREATHERS (Page 4-26).

7. Install upper rocker covers. See UPPER ROCKER COVERS (Page 4-24).
8. Install upper cooling lines.
  - a. **Twin-cooled engines:** See COOLANT HOSES (Page 7-13).
  - b. **Oil cooled engines:** See OIL COOLANT LINES (Page 4-20).
9. Install upper front engine mount. See FRONT ENGINE MOUNT (Page 4-22).
10. Connect horn and bracket. Secure harness. See HORN (Page 8-38).
11. Connect KS connectors. See KNOCK SENSOR (KS) (Page 8-97).
12. Connect ACR connectors. See AUTOMATIC COMPRESSION RELEASE (ACR) (Page 8-98).
13. Connect spark plug cables. See SPARK PLUG CABLES (Page 8-19).
14. Install exhaust system. See EXHAUST SYSTEM (Page 8-34).
15. Install rider right footboard. See RIDER FOOTRESTS (Page 3-142).
16. Install mid-frame air deflectors, if equipped. See AIR DEFLECTORS (Page 3-119).
17. Connect ET sensor. See ENGINE TEMPERATURE (ET) SENSOR (Page 8-96).
18. Install induction module. See INDUCTION MODULE (Page 6-26).
19. Install air filter backplate assembly. See AIR CLEANER BACKPLATE ASSEMBLY (Page 6-3).
20. Install air filter and cover. See INSPECT AIR FILTER (Page 2-46).
21. Install fuel tank. See FUEL TANK (Page 6-10).
22. Connect negative battery cable. See POWER DISCONNECT (Page 8-8).
23. Install seat. See SEAT (Page 3-148).

## CAM COMPARTMENT AND COMPONENTS

### PREPARE

#### REMOVE AND INSTALL: CAMSHAFT COVER

| FASTENER                    | TORQUE VALUE  |               |
|-----------------------------|---------------|---------------|
| Camshaft cover screws       | 90-120 in-lbs | 10.2-13.6 N-m |
| Camshaft timer cover screws | 25-35 in-lbs  | 2.8-4 N-m     |

#### NOTE

*Abrasive particles can damage machined surfaces or plug oil passageways. Clean parts before disassembly to prevent component damage.*

1. Use low-pressure compressed air to clean exterior surfaces of engine.
2. Remove seat. See SEAT (Page 3-148).
3. Disconnect negative battery cable. See POWER DISCONNECT (Page 8-8).
4. Remove fuel tank. See FUEL TANK (Page 6-10).
5. Remove air cleaner. See INSPECT AIR FILTER (Page 2-46).
6. Remove air cleaner backplate assembly. See AIR CLEANER BACKPLATE ASSEMBLY (Page 6-3).
7. Remove mid-frame air deflectors, if equipped. See AIR DEFLECTORS (Page 3-119).
8. Disconnect spark plug cables from spark plugs. See SPARK PLUG CABLES (Page 8-19).
9. Disconnect ACR connectors. See AUTOMATIC COMPRESSION RELEASE (ACR) (Page 8-98).
10. Disconnect fuel injector connectors. See FUEL INJECTORS (Page 6-25).
11. Disconnect KS connectors. See KNOCK SENSOR (KS) (Page 8-97).
12. Disconnect horn connector. See HORN (Page 8-38).
13. Remove upper front engine mount. See FRONT ENGINE MOUNT (Page 4-22).
14. Remove upper cooling lines.
  - a. **Twin-Cooled Engines:** See COOLANT HOSES (Page 7-13).
  - b. **Oil Cooled Engines:** See OIL COOLANT LINES (Page 4-20).
15. Remove upper rocker covers. See UPPER ROCKER COVERS (Page 4-24).
16. Loosen rocker arm screws to relieve tension on pushrods. See ROCKER ARMS (Page 4-30).

## Remove

1. See Figure 4-49. Remove camshaft cover.
  - a. Remove screws (3).
  - b. Remove camshaft cover (4).
  - c. Discard gasket (5).

## Install

1. See Figure 4-49. Install camshaft cover.
  - a. Install new gasket (5).
  - b. Install camshaft cover (4).
  - c. Install screws (3). Hand tighten.
  - d. See Figure 4-50. Tighten screws in sequence shown.  
Torque: 90-120 in-lbs (10.2-13.6 N-m) *Camshaft cover screws*
2. See Figure 4-49. Install timer cover, if removed.
  - a. Install timer cover (2).
  - b. Install screws (1). Tighten.  
Torque: 25-35 in-lbs (2.8-4 N-m) *Camshaft timer cover screws*

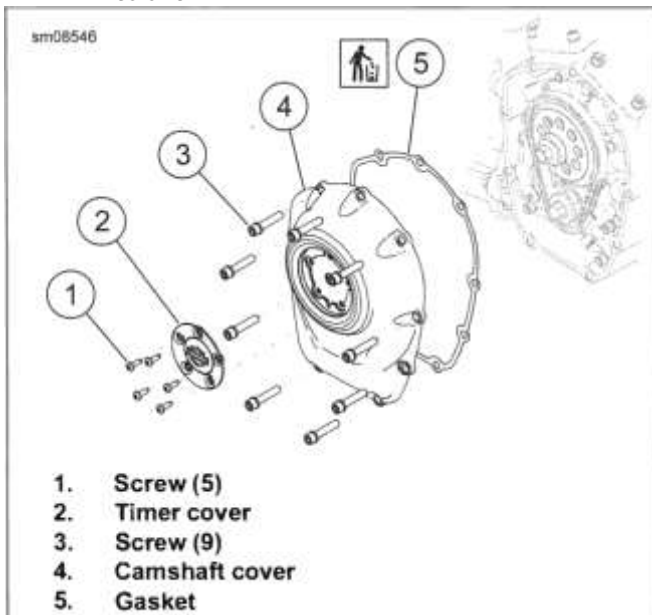


Figure 4-49. Camshaft Cover

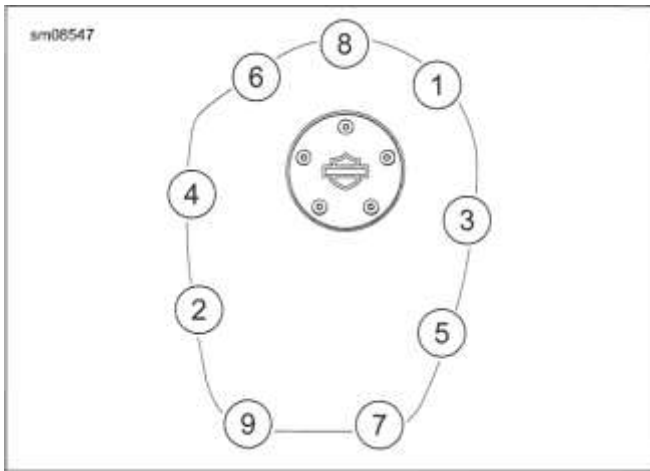


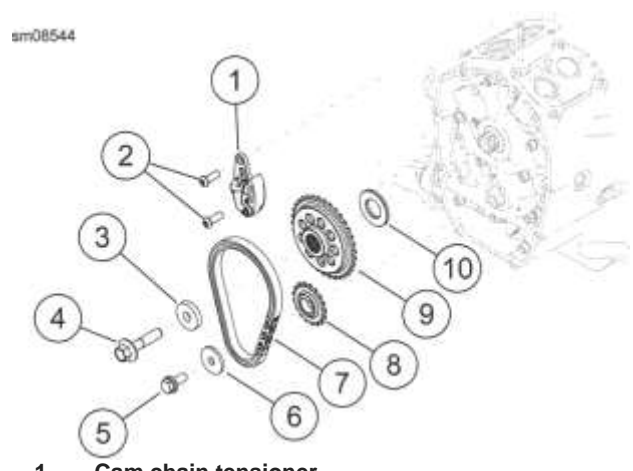
Figure 4-50. Cam Cover Tightening Sequence

**REMOVE**

| PART NUMBER | TOOLNAME                                  |
|-------------|---|
| 93979-10    | MAGNETIC LIFTER HOLDERS                   |
| HD-47941    | CRANKSHAFT/CAMSHAFT SPROCKET LOCKING TOOL |

**Camshaft Drive**

1. See Figure 4-51. Remove chain and sprockets.
  - a. Mark one chain link.
  - b. Remove screws (2) and cam chain tensioner (1).
  - c. Install sprocket locking tool between cam sprocket (9) and crank sprocket (8).  
Special Tool: CRANKSHAFT/CAMSHAFT SPROCKET LOCKING TOOL (HD-47941)
  - d. Remove cam sprocket screw (4) and washer (3).
  - e. Remove crank sprocket screw (5) and washer (6).
  - f. Remove sprocket locking tool.
  - g. Remove both sprockets and chain.
  - h. Remove spacer (10).



1. Cam chain tensioner
2. Screw (2)
3. Washer
4. Screw, cam sprocket
5. Screw, crank sprocket
6. Washer
7. Chain
8. Crank sprocket
9. Cam sprocket
10. Spacer

Figure 4-51. Camshaft Drive

**Camshaft**

1. Remove camshaft.
  - a. See Figure 4-52. Support lifters.  
Special Tool: MAGNETIC LIFTER HOLDERS (93979-10)
  - b. See Figure 4-53. Remove four screws (5).
  - c. Remove screws (1).
  - d. Remove cam support plate (2).
  - e. Remove camshaft (3).
  - f. Remove O-ring (4).

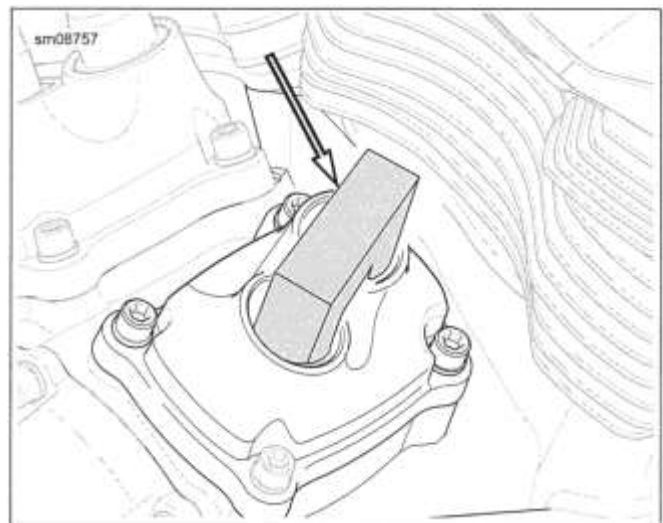


Figure 4-52. SCREAMIN' EAGLE Magnetic Lifter Holder

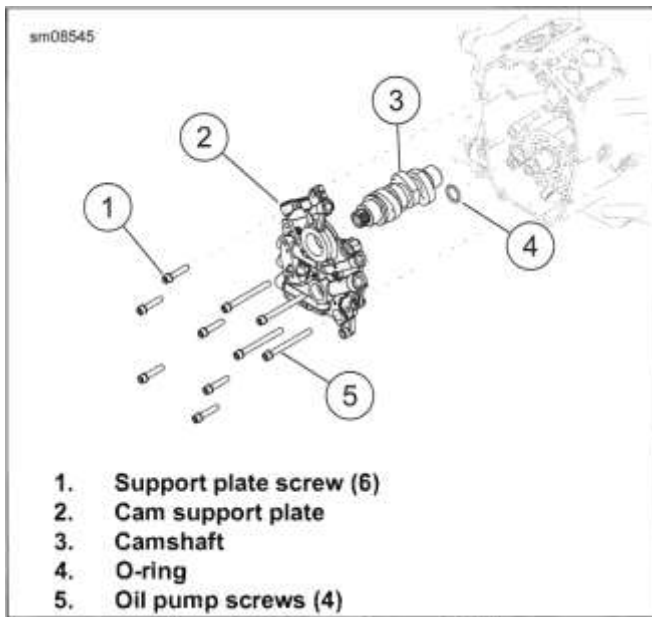


Figure 4-53. Cam Support Plate

## INSPECT CAM COMPONENT

### Camshaft

1. **NOTE**  
See *SPECIFICATIONS* (Page 4-3) for specifications.  
  
Inspect lobes for abnormal wear or discoloration.
2. Inspect bearing surfaces for scoring or discoloration.
3. Measure bearing journals.
4. If desired, remove and inspect lifters.
  - a. Mark lifters for installation in original location and orientation.
  - b. Remove lifters through camshaft cavity.
  - c. Measure lifters.

### Cam Support Plate

1. Measure camshaft and crankshaft bores.
2. Measure support plate flatness.
3. Inspect gerotor area for excessive wear or deep grooves.
4. Verify that all oil passages are clean and open.

### Cam Drive Components

1. Inspect sprockets and chain for wear.
2. Inspect cam chain tensioner for wear.

## INSTALL

| PART NUMBER | TOOL NAME                                 |
|-------------|---|
| HD-47941    | CRANKSHAFT/CAMSHAFT SPROCKET LOCKING TOOL |

| FASTENER  | TORQUE VALUE  |               |
|---|---------------|---------------|
| Cam chain tensioner fasteners                     | 90-120 in-lbs | 10.2-13.6 N-m |
| Cam support plate screws                          | 90-120 in-lbs | 10.2-13.6 N-m |
| Camshaft sprocket screw, 1st torque               | 15.0 ft-lbs   | 20.3 N-m      |
| Camshaft sprocket screw, alignment check torque   | 15.0 ft-lbs   | 20.3 N-m      |
| Camshaft sprocket screw, final torque             | 34 ft-lbs     | 46.1 N-m      |
| Crankshaft sprocket screw, 1st torque             | 15.0 ft-lbs   | 20.3 N-m      |
| Crankshaft sprocket screw, alignment check torque | 15.0 ft-lbs   | 20.3 N-m      |
| Crankshaft sprocket screw, final torque           | 24 ft-lbs     | 32.5 N-m      |
| Oil pump screws, 1st torque                       | 12-60 in-lbs  | 1.4-6.8 N-m   |
| Oil pump screws, final torque                     | 90-120 in-lbs | 10.2-13.6 N-m |

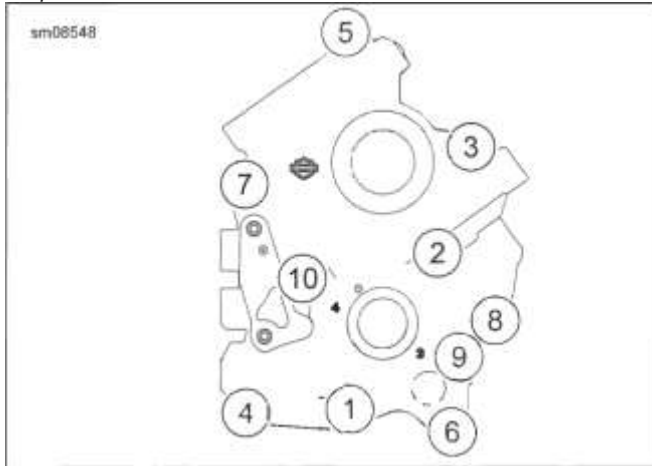
| PART NUMBER | CONSUMABLE   |
|-------------|--|
| 11300002    | SCREAMIN' EAGLE ASSEMBLY LUBE                            |
| 94759-99    | LOCTITE 262 HIGH STRENGTH THREADLOCKER AND SEALANT (RED) |

1. Apply assembly lube to all bearing surfaces and bearings.  
  
Consumable: SCREAMIN' EAGLE ASSEMBLY LUBE (11300002)
2. See Figure 4-53. Install cam and cam support plate.
  - a. Install camshaft in crankcase.
  - b. Install new O-ring (4) into crankcase feed oil port.
  - c. Apply assembly lube to cam support plate feed oil port.  
  
SCREAMIN' EAGLE ASSEMBLY LUBE (11300002)
  - d. Slide cam support plate over shafts and mate to crankcase.
  - e. Verify cam support plate is fully seated.
  - f. Start all screws.
3. See Figure 4-54. Tighten screws in sequence.
  - a. Tighten screws (1,2).  
Torque: 12-60 in-lbs (1.4-6.8 N-m) *Oil pump screws, 1st torque*
  - b. Rotate crankshaft one full revolution (360 degrees).
  - c. Tighten screws (3-8) in sequence shown.  
  
Torque: 90-120 in-lbs (10.2-13.6 N-m) *Cam support plate screws*

d. Final tighten four oil pump screws (1-2, 9-10) in same

j. Remove cam sprocket.

Torque: 90-120 **in-lbs** (10.2-13.6 N-m) *Oil pump screws, final torque*



**Figure 4-54. Cam Support Plate Tightening Sequence**  
sequence.

**Table 4-33. Cam Sprocket Spacers**

| PART NO. | IN    | MM   |
|----------|-------|------|
| 25729-06 | 0.100 | 2.54 |
| 25731-06 | 0.110 | 2.79 |
| 25734-06 | 0.120 | 3.05 |
| 25736-06 | 0.130 | 3.30 |
| 25737-06 | 0.140 | 3.56 |
| 25738-06 | 0.150 | 3.81 |

5. Install camshaft drive.

4. **NOTE**

Check sprocket alignment if any following parts are **new**:

- Cam sprocket
- Cam support plate
- Camshaft
- Crankshaft sprocket
- Flywheel assembly

Check sprocket alignment.

- See Figure 4-51. Install original cam sprocket spacer (10).
- Install cam sprocket without chain using screw (4) and washer (3).
- Install crankshaft sprocket without chain using screw (5) and a smaller diameter flat washer from bulk inventory.
- Install sprocket locking tool between sprockets.  
Special Tool: CRANKSHAFT/CAMSHAFT SPROCKET LOCKING TOOL (HD-47941)
- Tighten camshaft sprocket screw.  
Torque: 15.0 ft-lbs (20.3 N-m) *Camshaft sprocket screw, alignment check torque*
- Tighten crankshaft sprocket screw.  
Torque: 15.0 ft-lbs (20.3 N-m) *Crankshaft sprocket screw, alignment check torque*
- Remove sprocket locking tool.
- Push on crankshaft and camshaft to eliminate end play.
- Place a straightedge across sprocket faces. Alignment offset maximum.

Length/Dimension/Distance: 0.009 in (0.23 mm)



k. Install appropriate spacer (10) using Table 4-33 as a guide.

l. Check alignment with **new** spacer installed.

m. Remove both sprockets.

a. Apply assembly lube to camshaft and crankshaft.

SCREAMIN' EAGLE ASSEMBLY LUBE (11300002)

b. Install cam sprocket spacer (10).

c. See Figure 4-55. Assemble sprockets and chain with timing marks aligned. Verify marked chain link is on the same side as the timing marks.

d. Rotate camshaft until keyed spline is up.

e. Rotate crankshaft until flat is up.

f. Install sprockets and chain.

g. Verify that timing marks on sprockets are aligned.

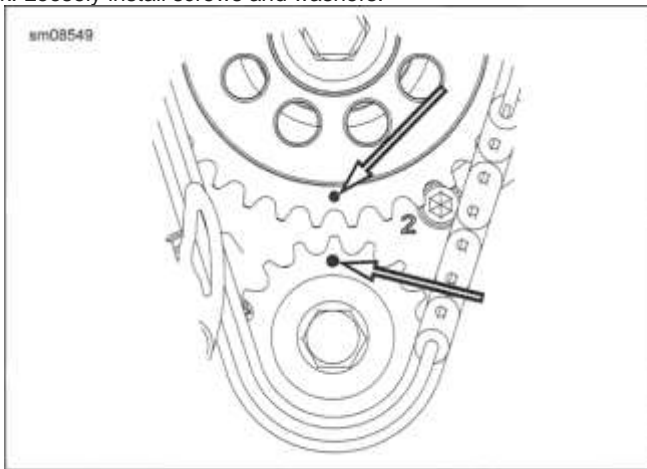
h. If reusing screws, clean old threadlocker from screws and mating components.

i. Apply threadlocker (red) to both screws.

LOCTITE 262 HIGH STRENGTH THREADLOCKER  
AND SEALANT (RED) (94759-99)

j. Apply a film of oil to bottom of both sprocket screw heads and washers.

k. Loosely install screws and washers.



**Figure 4-55. Timing Marks**

6. Tighten sprocket screws.
  - a. Position sprocket locking tool between sprockets.  
Special Tool: CRANKSHAFT/CAMSHAFT SPROCKET LOCKING TOOL (HD-47941)
  - b. Tighten camshaft sprocket screw.  
Torque: 15.0 ft-lbs (20.3 N-m) *Camshaft sprocket screw, 1st torque*
  - c. Tighten crankshaft sprocket screw.  
Torque: 15.0 ft-lbs (20.3 N-m) *Crankshaft sprocket screw, 1st torque*
  - d. Loosen both screws one revolution (360 degrees).
  - e. Final tighten camshaft sprocket screw.  
Torque: 34 ft-lbs (46.1 N-m) *Camshaft sprocket screw, final torque*
  - f. Final tighten crankshaft sprocket screw.  
Torque: 24 ft-lbs (32.5 N-m) *Crankshaft sprocket screw, final torque*
  - g. Remove sprocket locking tool.
7. Install primary cam chain tensioner. Tighten.  
Torque: 90-120 **in-lbs** (10.2-13.6 N-m) *Cam chain tensioner fasteners*
8. Apply SCREAMIN' EAGLE ASSEMBLY LUBE to chain and sprockets.

## COMPLETE

1. Install rocker arms. See **ROCKER ARMS** (Page 4-30).
2. Install upper rocker covers. See **UPPER ROCKER COVERS** (Page 4-24).
3. Install upper cooling lines.
  - a. **Twin-cooled engines:** See **COOLANT HOSES** (Page 7-13).
  - b. **Oil cooled engines:** See **OIL COOLANT LINES** (Page 4-20).
4. Install upper front engine mount. See **FRONT ENGINE MOUNT** (Page 4-22).
5. Connect horn connector. Secure harness. See **HORN** (Page 8-38).
6. Connect KS connectors. See **KNOCK SENSOR (KS)** (Page 8-97).
7. Connect fuel injector connectors. See **FUEL INJECTORS** (Page 6-25).
8. Connect ACR connectors. See **AUTOMATIC COMPRESSION RELEASE (ACR)** (Page 8-98).
9. Connect spark plug cables. See **SPARK PLUG CABLES** (Page 8-19).

10. Install mid-frame air deflectors, if equipped. See **AIR DEFLECTORS** (Page 3-119).
11. Install fuel tank. See **FUEL TANK** (Page 6-10).
12. Install air cleaner backplate assembly. See **AIR CLEANER BACKPLATE ASSEMBLY** (Page 6-3).
13. Install air cleaner. See **INSPECT AIR FILTER** (Page 2-46).
14. Connect negative battery cable. See **POWER DISCONNECT** (Page 8-8).
15. Install seat. See **SEAT** (Page 3-148).

| PART NUMBER | TOOL NAME                                 |
|-------------|---|
| HD-42325-C  | CAMSHAFT NEEDLE BEARING REMOVER/INSTALLER |

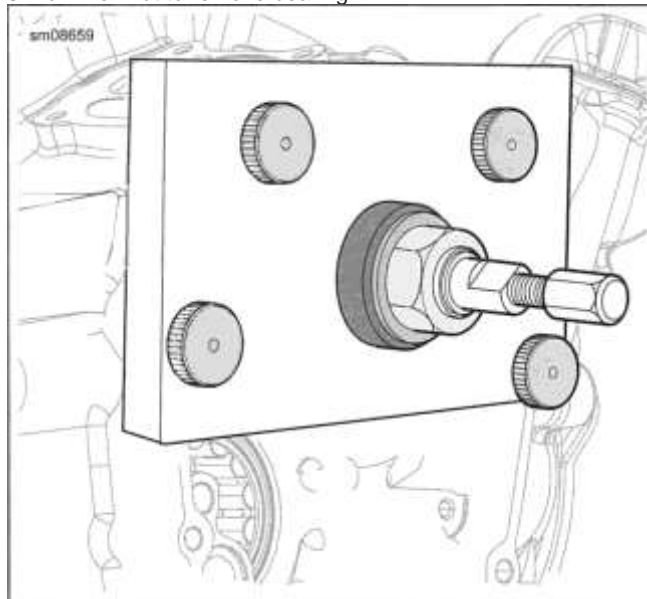
| FASTENER                                       | TORQUE VALUE |          |
|--|--------------|----------|
| Cam needle bearing installation maximum torque | 25 ft-lbs    | 33.9 N-m |

## CAMSHAFT NEEDLE BEARINGS

### Remove

1. See Figure 4-56. Remove camshaft bearing.  
Special Tool: CAMSHAFT NEEDLE BEARING REMOVER/INSTALLER (HD-42325-C)

3. Turn hex nut to remove bearing.



**Figure 4-56. Remove Camshaft Needle Bearing Install**

2. Hold flat on collet. Turn hex at end to expand collet.

1. Calculate bearing installed depth.
  - a. Measure support plate thickness.

- b. Add support plate thickness to 3.737 in (94.92 mm). Record this value.

- 2. See Figure 4-56. Install bearing.

Special Tool: CAMSHAFT NEEDLE BEARING REMOVER/INSTALLER (HD-42325-C)

- a. Place new needle bearing on installer with letters facing installer.
- b. Install support plate.

- 3. See Figure 4-57. Turn forcing screw to press needle bearing to depth calculated earlier  $\pm 0.020$  in (0.54 mm).

- a. Do not exceed torque specification during needle bearing installation or damage to crankcase will occur.

Torque: 25 ft-lbs (33.9 N-m) *Cam needle bearing installation maximum torque*

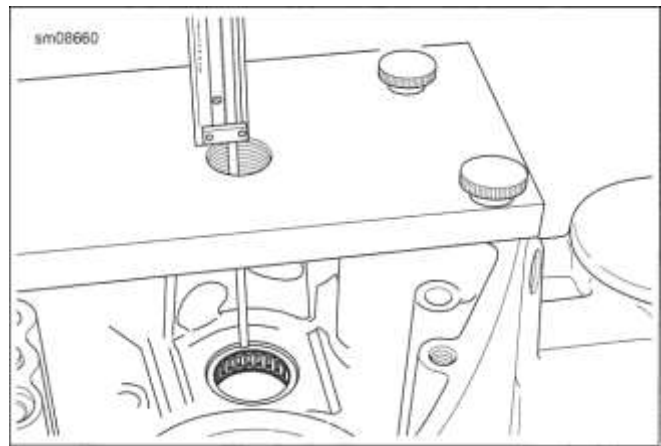


Figure 4-57. Measure from Top of Support Plate to Edge of Needle Bearing

**PREPARE***NOTE*

*Abrasive particles can damage machined surfaces or plug oil passageways. Clean parts before disassembly to prevent component damage.*

1. Use low-pressure compressed air to clean exterior surfaces of engine.
2. Remove seat. See SEAT (Page 3-148).
3. Disconnect negative battery cable. See POWER DISCONNECT (Page 8-8).

4. *NOTE*

*Detach right rider footrest only if necessary to remove exhaust.*

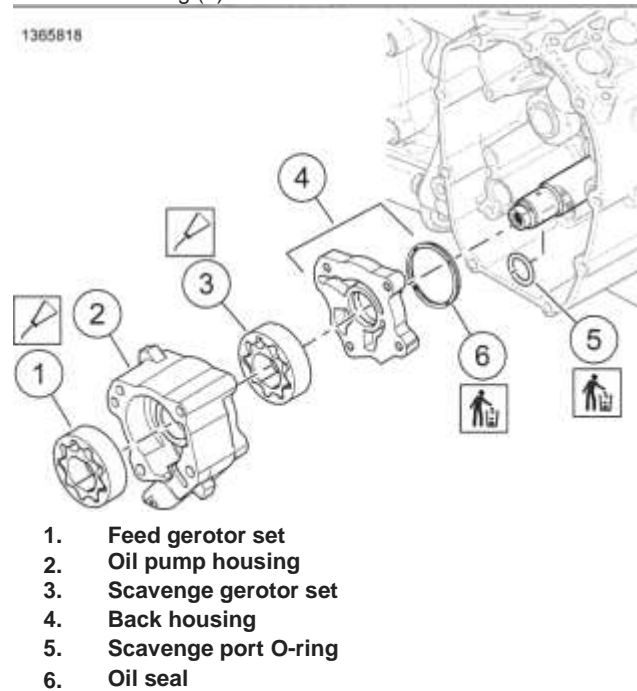
Detach right rider footrest. See RIDER FOOTRESTS (Page 3-142).

5. Remove exhaust header pipe. See EXHAUST SYSTEM (Page 6-34).
6. Remove fuel tank. See FUEL TANK (Page 6-10).
7. Remove air cleaner. See INSPECT AIR FILTER (Page 2-46).
8. Remove air cleaner backplate assembly. See AIR CLEANER BACKPLATE ASSEMBLY (Page 6-3).
9. Remove mid-frame air deflectors, if equipped. See AIR DEFLECTORS (Page 3-119).
10. Disconnect spark plug cables from spark plugs. See SPARK PLUG CABLES (Page 8-19).
11. Disconnect ACR connectors. See AUTOMATIC COMPRESSION RELEASE (ACR) (Page 8-98).
12. Disconnect fuel injector connectors. See FUEL INJECTORS (Page 6-25).
13. Disconnect KS connectors. See KNOCK SENSOR (KS) (Page 8-97).
14. Disconnect horn connector. See HORN (Page 8-38).
15. Remove upper front engine mount. See FRONT ENGINE MOUNT (Page 4-22).
16. Remove upper cooling lines.
  - a. **Twin-Cooled Engines:** See COOLANT HOSES (Page 7-13).
  - b. **Oil Cooled Engines:** See OIL COOLANT LINES (Page 4-20).

17. Remove upper rocker covers. See UPPER ROCKER COVERS (Page 4-24).
18. Loosen rocker arm screws to relieve tension on pushrods. See ROCKER ARMS (Page 4-30).
19. Remove camshaft cover and cam support plate. See CAM COMPARTMENT AND COMPONENTS (Page 4-52).

**REMOVE**

1. See Figure 4-58. Remove oil pump assembly from camshaft compartment.
2. Discard oil seal (6).
3. Discard O-ring (5).



**Figure 4-58. Oil Pump**

**DISASSEMBLE AND INSPECT**

1. See Figure 4-58. Remove gerotors (1,3).
2. See Figure 4-59. Remove pressure relief valve.
  - a. Hold spring (1) compressed.
  - b. Drive out roll pin (3).
  - c. Carefully release spring pressure.
  - d. Remove spring and piston (2).
3. Clean parts in a non-volatile cleaning solution.
4. Dry parts using low-pressure compressed air.

5. Inspect housing.
  - a. Verify oil holes are clean and open.
  - b. Inspect relief valve piston and seat for damage.
  - c. Inspect oil pump housing bores for scoring, gouging or cracking.
  - d. See Figure 4-58. Inspect for grooves or scratches on cam support plate and back housing (4).
6. See Figure 4-60. Check gerotor wear.
  - a. Check lobes of gerotors for damage.
  - b. Mesh gerotor sets together.
  - c. Measure distance between tips of lobes on inner and outer feed gerotor set.
  - d. Measure distance between tips of lobes on inner and outer scavenge gerotor set.
  - e. Refer to Table 4-34. Compare measurements to maximum specification.
  - f. Measure and compare thickness of each rotor in feed gerotor set.
  - g. Measure and compare thickness of each rotor in scavenge gerotor set.
  - h. Refer to Table 4-34. Compare measurements to maximum specification.

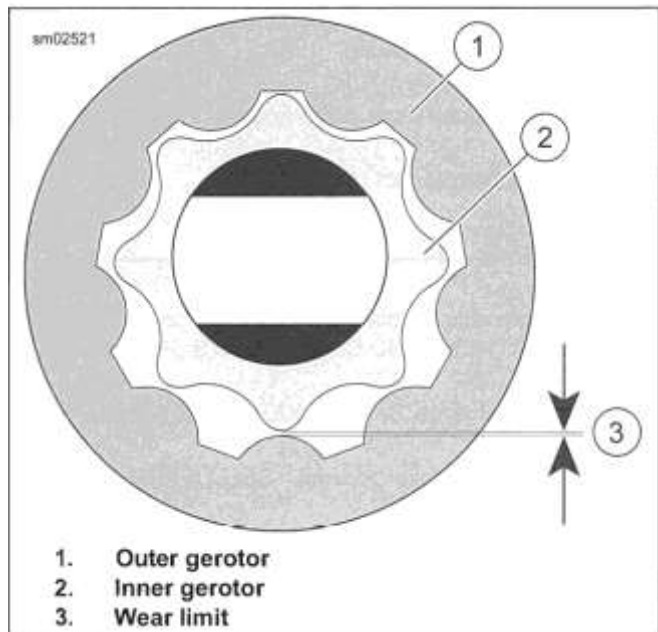


Figure 4-60. Measure Gerotor Sets for Wear

Table 4-34. Oil Pump Feed and Scavenge Gerotor Tolerances

| MAXIMUM LOBE CLEAR-ANCE | MAXIMUM THICKNESS DIF-FERENCE |
|-------------------------|-------------------------------|
| 0.004 in (0.1 mm)       | 0.001 in (0.025 mm)           |

#### ASSEMBLE

| PART NUMBER | CONSUMABLE                    |
|-------------|-------------------------------|
| 11300002    | SCREAMIN' EAGLE ASSEMBLY LUBE |

1. Install pressure relief valve.

- a. See Figure 4-59. Apply assembly lube to piston (2) and bore.

Consumable: SCREAMIN' EAGLE ASSEMBLY LUBE (11300002)

- b. Install piston and spring (1).
- c. Hold spring compressed and install roll pin (3).

#### INSTALL

| PART NUMBER | CONSUMABLE                    |
|-------------|-------------------------------|
| 11300002    | SCREAMIN' EAGLE ASSEMBLY LUBE |

1. Lubricate all parts with assembly lube during assembly.  
Consumable: SCREAMIN' EAGLE ASSEMBLY LUBE (11300002)
2. See Figure 4-58. Install **new** oil seal (6) on back housing (4).
3. Install back housing (4) and scavenge gerotor set (3) onto crankshaft.
4. Install **new** O-ring (5) in crankcase scavenge port.
5. Apply assembly lube to scavenge port spigot.  
Consumable: SCREAMIN' EAGLE ASSEMBLY LUBE (11300002)

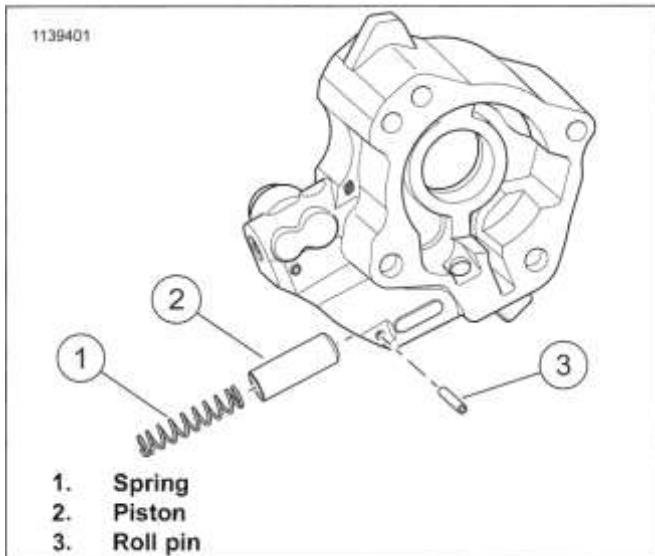


Figure 4-59. Oil Pressure Relief Valve

6. Slide oil pump housing (4) onto crankshaft while fitting scavenge port into O-ring.
  - a. Firmly push on oil pump housing to fully seat.
7. Install feed gerotor set (1).

## **COMPLETE**

---

1. Install cam support plate and camshaft cover. See CAM COMPARTMENT AND COMPONENTS (Page 4-52).
2. Install rocker arms. See ROCKER ARMS (Page 4-30).
3. Install upper rocker covers. See UPPER ROCKER COVERS (Page 4-24).
4. Install upper cooling lines.
  - a. **Twin-cooled engines:** See COOLANT HOSES (Page 7-13).
  - b. **Oil cooled engines:** See OIL COOLANT LINES (Page 4-20).
5. Install upper front engine mount. See FRONT ENGINE MOUNT (Page 4-22).
6. Connect horn connector. Secure harness. See HORN (Page 8-38).
7. Connect KS connectors. See KNOCK SENSOR (KS) (Page 8-97).
8. Connect fuel injector connectors. See FUEL INJECTORS (Page 6-25).
9. Connect ACR connectors. See AUTOMATIC COMPRESSION RELEASE (ACR) (Page 8-98).
10. Connect spark plug cables. See SPARK PLUG CABLES (Page 8-19).
11. Install mid-frame air deflectors, if equipped. See AIR DEFLECTORS (Page 3-119).
12. Install fuel tank. See FUEL TANK (Page 6-10).
13. Install air cleaner backplate assembly. See AIR CLEANER BACKPLATE ASSEMBLY (Page 6-3).
14. Install air cleaner. See INSPECT AIR FILTER (Page 2-46).
15. Install exhaust header pipe. See EXHAUST SYSTEM (Page 6-34).
16. Attach rider right footrest, if removed. See RIDER FOOTRESTS (Page 3-142).
17. Connect negative battery cable. See POWER DISCONNECT (Page 8-8).
18. Install seat. See SEAT (Page 3-148).

## PREPARE.

### Prepare

1. Secure motorcycle on lift. See GENERAL (Page 2-3).
2. Remove seat. See SEAT (Page 3-148).
3. Disconnect negative battery cable. See POWER DISCONNECT (Page 8-8).
4. Remove fuel tank. See FUEL TANK (Page 6-10).
5. Remove air filter. See INSPECT AIR FILTER (Page 2-46).
6. Remove air filter backplate assembly. See AIR CLEANER BACKPLATE ASSEMBLY (Page 6-3).
7. Remove induction module assembly. See INDUCTION MODULE (Page 6-26).
8. Remove mid-frame air deflectors, if equipped. See AIR DEFLECTORS (Page 3-119).
9. Remove rider right footboard. See RIDER FOOTRESTS (Page 3-142). "
10. Remove exhaust system. See EXHAUST SYSTEM (Page 6-34).
11. Remove upper cooling lines.
  - a. **Twin-Cooled Engines:** See COOLANT HOSES (Page 7-13).
  - b. **Oil Cooled Engines:** See OIL COOLANT LINES (Page 4-20).
12. Drain engine oil and discard filter. See REPLACE ENGINE OIL AND FILTER (Page 2-9).
13. Disconnect CKP sensor connector. See CRANKSHAFT POSITION SENSOR (CKP) (Page 8-95).
14. Remove voltage regulator. See VOLTAGE REGULATOR (Page 8-14).
  - a. Release stator harness anchor.
15. Disconnect oil pressure sender connector. See OIL PRESSURE SWITCH (Page 8-36).
16. Remove primary chaincase. See PRIMARY CHAINCASE HOUSING (Page 5-25).
17. Remove alternator rotor. See ALTERNATOR (Page 8-12).

18. Release main harness and brake line from lower frame rail.
  - a. Allow to hang below frame.
19. Disconnect ACR connectors. See AUTOMATIC COMPRESSION RELEASE (ACR) (Page 8-98).
20. Disconnect KS connectors. See KNOCK SENSOR (KS) (Page 8-97).
21. Disconnect ET sensor connector. See ENGINE TEMPERATURE (ET) SENSOR (Page 8-96).
22. Disconnect spark plug cables from spark plugs. See SPARK PLUG CABLES (Page 8-19).
23. Remove horn and bracket. See HORN (Page 8-38).

## REMOVE

| PART NUMBER | TOOL NAME |
|-------------|-----------|
| HD-45968    | FAT JACK  |

### Remove

1. Wrap rear master cylinder with protective padding.
2. Wrap rocker covers and lower frame rails with protective padding.
3. Support transmission.  
Special Tool: FAT JACK (HD-45968)
4. Remove four transmission to engine bolts.
5. Remove upper front engine mount and bracket. See FRONT ENGINE MOUNT (Page 4-22).
6. Remove lower front engine mount. See FRONT ENGINE MOUNT (Page 4-22).
7. Remove engine from chassis.
  - a. Move engine forward to clear dowels.
  - b. Remove engine from right side.

## INSTALL

### Install

1. Make sure motorcycle is secure on lift.
2. Install powertrain into chassis.
  - a. Install engine from right side.
  - b. Position in chassis.

- c. Move engine rearward to engage transmission 11. Connect CKP sensor connector. See CRANKSHAFT dowels. POSITION SENSOR (CKP) (Page 8-95).
- 3. Install lower front engine mount. See FRONT ENGINE 12. Fill engine oil and install new filter. See REPLACE ENGINE MOUNT OIL AND FILTER (Page 2-9).
- 4. Install four transmission to engine bolts. See TRANSMISSION CASE (Page 5-47).
  - a. **Twin-Cooled Engines:** See COOLANT HOSES (Page 7-13).
  - b. **Oil Cooled Engines:** See OIL COOLANT LINES (Page 4-20).
- 5. Remove transmission support.
- 6. Install upper front engine mount. See FRONT ENGINE MOUNT (Page 4-22).
- 7. Remove protective padding from rear master cylinder, rocker covers and lower frame rails.
- 14. Install exhaust system. See EXHAUST SYSTEM (Page 6-34).
- 15. Install rider right footboard. See RIDER FOOTRESTS (Page 3-142).

## **COMPLETE**

---

### **Complete**

- 1. Install horn and bracket. See HORN (Page 8-38).
- 2. Connect spark plug cables. See SPARK PLUG CABLES (Page 8-19).
- 3. Connect ET sensor connector. See ENGINE TEMPERATURE (ET) SENSOR (Page 8-96).
- 4. Connect KS connectors. See KNOCK SENSOR (KS) (Page 8-97).
- 5. Connect ACR connectors. See AUTOMATIC COMPRESSION RELEASE (ACR) (Page 8-98).
- 6. Secure main harness and brake line to lower frame rail.
- 7. Install alternator rotor and stator. See ALTERNATOR (Page 8-12).
- 8. Install primary chaincase. See PRIMARY CHAINCASE HOUSING (Page 5-25).
- 9. Connect oil pressure sender connector. See OIL PRESSURE SWITCH (Page 8-36).
- 10. Install voltage regulator. See VOLTAGE REGULATOR (Page 8-14).
- 13. Install upper cooling lines.
- 16. Install mid-frame air deflectors, if equipped. See AIR DEFLECTORS (Page 3-119).
- 17. Install induction module. See INDUCTION MODULE (Page 6-26).
- 18. Install air filter backplate assembly. AIR CLEANER BACKPLATE ASSEMBLY (Page 6-3).
- 19. Install air filter. See INSPECT AIR FILTER (Page 2-46).
- 20. Install fuel tank. See FUEL TANK (Page 6-10).
- 21. Connect negative battery cable. See POWER DISCONNECT (Page 8-8).
- 22. Install seat. See SEAT (Page 3-148).
- 23. Run motorcycle until engine is at normal operating temperature.
  - a. Check clutch operation. Adjust if needed.
  - b. Check instrument lamps.
  - c. Check for leaks.
  - d. Check engine oil level (hot).



**PREPARE**

1. Remove engine. See REPLACE ENGINE (Page 4-61).

2. **NOTE**  
*Abrasive particles can damage machined surfaces or plug oil passageways. Clean parts before disassembly to prevent component damage.*

Use low-pressure compressed air to clean exterior surfaces of engine.

3. Remove upper rocker covers. See UPPER ROCKER COVERS (Page 4-24).

4. Remove breathers. See BREATHERS (Page 4-26).

5. Remove lower rocker covers. See LOWER ROCKER COVERS (Page 4-28).

6. Remove rocker arms. See ROCKER ARMS (Page 4-30).

7. Remove pushrods. See PUSHRODS, LIFTERS AND COVERS (Page 4-32).

8. Remove cylinder heads. See CYLINDER HEADS (Page 4-36).

9. Remove cylinders. See CYLINDERS (Page 4-42).

10. Remove pistons. See PISTONS (Page 4-46).

c. See Figure 4-62. Lift left crankcase half (2) off end of crankshaft.

3. Remove two dowel pins in split line face of right case half.

4. Remove balancer (4).

Special Tool: BALANCER SCISSOR GEAR ALIGNMENT TOOL (HD-52065)

a. Install Balancer scissor gear alignment tool.

b. Lift balancer from crankcase.

5. Remove flywheel assembly (3).

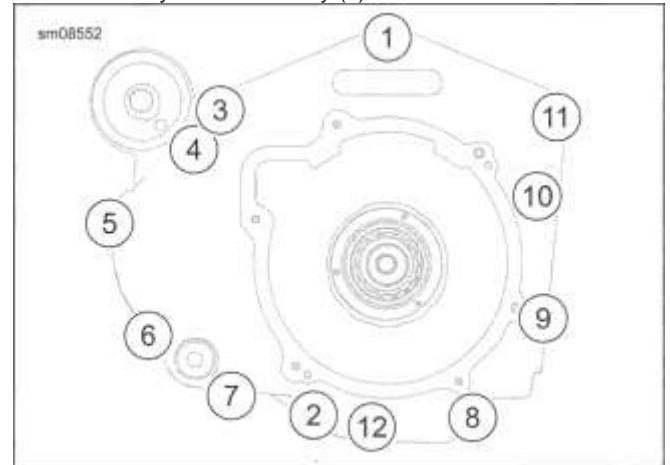


Figure 4-61. Crankcase Torque Sequence

**DISASSEMBLE**

| PART NUMBER | TOOLNAME                             |
|-------------|--------------------------------------|
| HD-52065    | BALANCER SCISSOR GEAR ALIGNMENT TOOL |

**A CAUTION**

**Do not rotate crankcase half in engine stand when flywheel is installed. The flywheel assembly can fall out, resulting in parts damage or moderate injury. (00552c)**

1. Position crankcase with cam compartment facing down.

**NOTE**  
*Never move or lift crankcase by grasping cylinder studs.*

2. **NOTE**  
*Prevent balancer gear from raising when lifting off left crankcase. Scissor gear may unload.*

Separate crankcase halves.

a. See Figure 4-61. Remove crankcase screws in sequence shown.

b. Separate case halves.

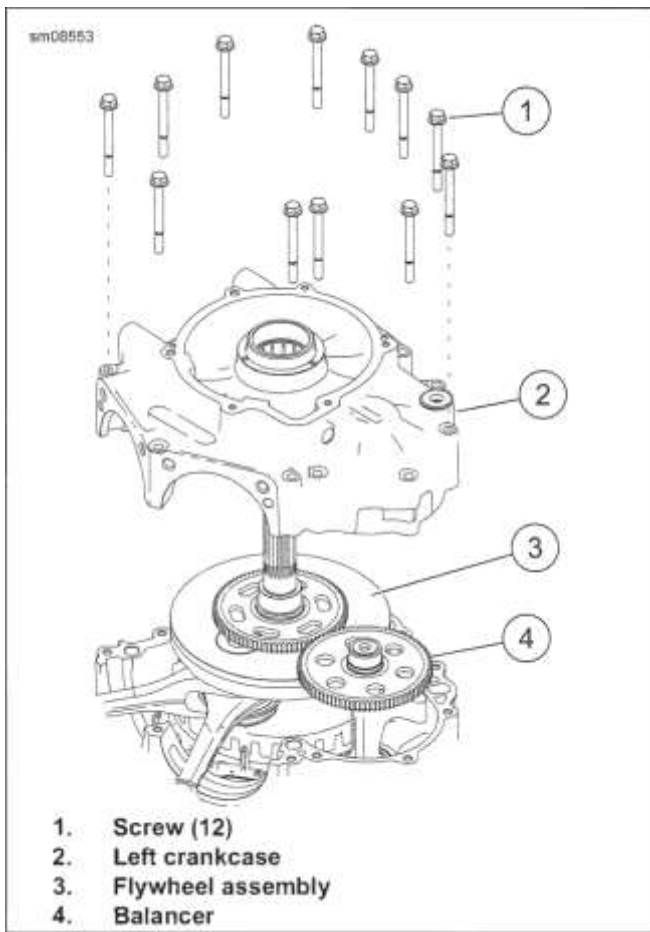


Figure 4-62. Separate Crankcase Halves

### CLEAN AND INSPECT

1. Remove all gasket material from crankcase flanges.
2. Clean all parts in a non-volatile cleaning solution or solvent.

### A WARNING

Compressed air can pierce the skin and flying debris from 3. compressed air could cause serious eye injury. Wear safety glasses when working with compressed air. Never use your hand to check for air leaks or to determine air flow rates. (00061 a)

3. Dry parts with moisture-free compressed air.
4. Verify oil holes are clean and open.
5. Check ring dowels for looseness, wear or damage. Replace if necessary.
6. Use file to carefully remove any nicks or burrs from machined surfaces.
7. Clean tapped holes and damaged threads.
8. Check top of crankcase for flatness with a straightedge and feeler gauge. Replace if warped.
9. Spray all machined surfaces with clean engine oil.

10. Inspect crankshaft/flywheel assembly. See FLYWHEEL AND CONNECTING RODS (Page 4-73).

### ASSEMBLE

| PART NUMBER  | TOOL NAME                                    |
|--------------|--|
| HD-42326-B   | CRANKSHAFT GUIDE                             |
| HD-52064     | LEFT MAIN BEARING OIL SEAL INSTALLATION TOOL |
| HD-52065     | BALANCER SCISSOR GEAR ALIGNMENT TOOL         |
| HD-97225-55C | SPROCKET SHAFT BEARING INSTALLER             |

| FASTENER                       | TORQUE VALUE |               |
|--------------------------------|--------------|---------------|
| Crankcase screws, 1st torque   | 120 in-lbs   | 13.6 N-m      |
| Crankcase screws, final torque | 15-19 ft-lbs | 20.3-25.8 N-m |

| PART NUMBER | CONSUMABLE                                      |
|-------------|---|
| 11300002    | SCREAMIN' EAGLE ASSEMBLY LUBE                   |
| 99650-02    | HARLEY-DAVIDSON HIGH PERFORMANCE SEALANT - GRAY |

1. Position right crankcase with cam compartment facing down.

2. Install flywheel assembly.

- a. Work generous amount of assembly lube into both main and balancer bearings.

SCREAMIN' EAGLE ASSEMBLY LUBE (11300002)

- b. Slide crankshaft guide onto flywheel sprocket shaft.  
Special Tool: CRANKSHAFT GUIDE (HD-42326-B)
- c. Slide flywheel assembly into right crankcase half.

d. Remove crankshaft guide tool.

### NOTE

See Figure 4-63. When aligning timing marks match dash to dash.

Timing marks may not align exactly. Align to closest tooth.

See Figure 4-63. Install balancers.

- a. Rotate flywheel so crankpin is at BDC.
- b. Install balancer while aligning timing marks (2).

4. Remove alignment tool.

Special Tool: BALANCER SCISSOR GEAR ALIGNMENT TOOL (HD-52065)

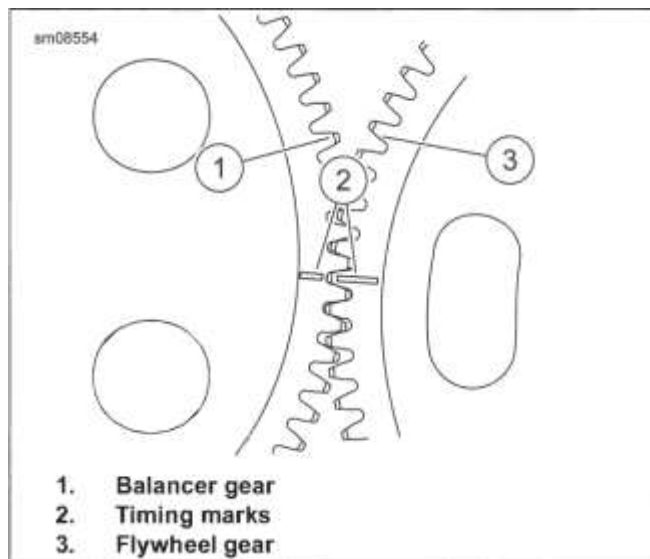
- a. Rotate gear teeth slightly with screwdriver to unload pressure on tool.
- b. Remove tool.

**NOTE**

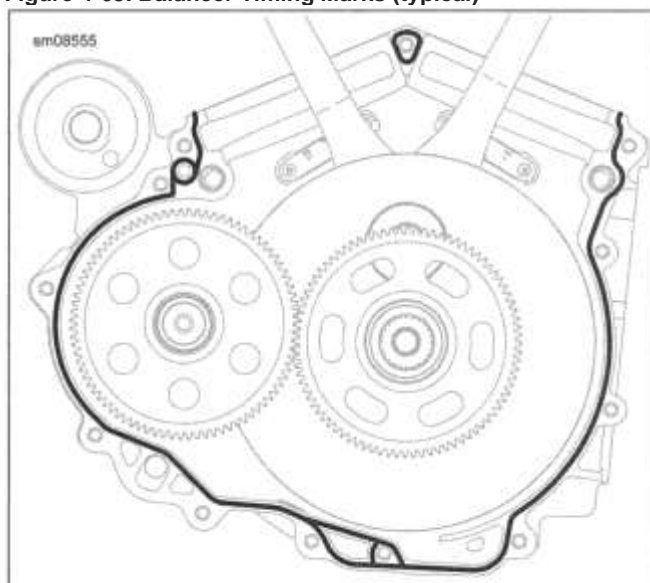
5. *The balancer shaft may splay away from crankshaft. Wiggle crankcase during installation to help fully seat balancer shaft in bearing.*

Mate crankcase halves.

- a. Verify that both dowel pins are installed in split line face of right case half.
  - b. See Figure 4-64. Apply specified bead of sealant to split line face of right crankcase half.  
0.06 in (1.52 mm) HARLEY-DAVIDSON HIGH PERFORMANCE SEALANT - GRAY (99650-02)
  - c. Place crankshaft guide over end of crankshaft until it contacts shoulder on shaft.  
Special Tool: CRANKSHAFT GUIDE (HD-42326-B)
  - d. Mate case halves. Keep crankcase splitline parallel as left crankcase is lowered into place.
  - e. Wiggle crankcase during installation to help fully seat balancer shafts in bearing.
  - f. Remove crankshaft guide.
6. See Figure 4-61. Install crankcase screws.
- a. Finger-tighten each screw.
  - b. Tighten screws in sequence shown.  
Torque: 120 **in-lbs** (13.6 N-m) *Crankcase screws, 1st torque*
  - c. Loosen, then following same sequence, final tighten.  
Torque: 15-19 **ft-lbs** (20.3-25.8 N-m) *Crankcase screws, final torque*
7. Rotate crankcase assembly so sprocket shaft is pointing straight up.
8. Install thrust washer on sprocket shaft with "THIS SIDE OUT" facing out (chamfer inboard). If using original part without markings, position to preserve existing wear pattern.
9. See Figure 4-65. Install **new** sprocket shaft oil seal using components from following tools.  
Special Tool: SPROCKET SHAFT BEARING INSTALLER (HD-97225-55C)  
Special Tool: LEFT MAIN BEARING OIL SEAL INSTALLATION TOOL (HD-52064)
- a. Verify lip garter spring is in place on both sides of oil seal.
  - b. Install sprocket shaft spacer.
  - c. Install oil seal.
10. Rotate crankcase so that cam compartment is facing up.
11. Apply generous amount of assembly lube to main bearing. Rotate flywheel assembly to distribute lube.



**Figure 4-63. Balancer Timing Marks (typical)**



**Figure 4-64. Sealant**

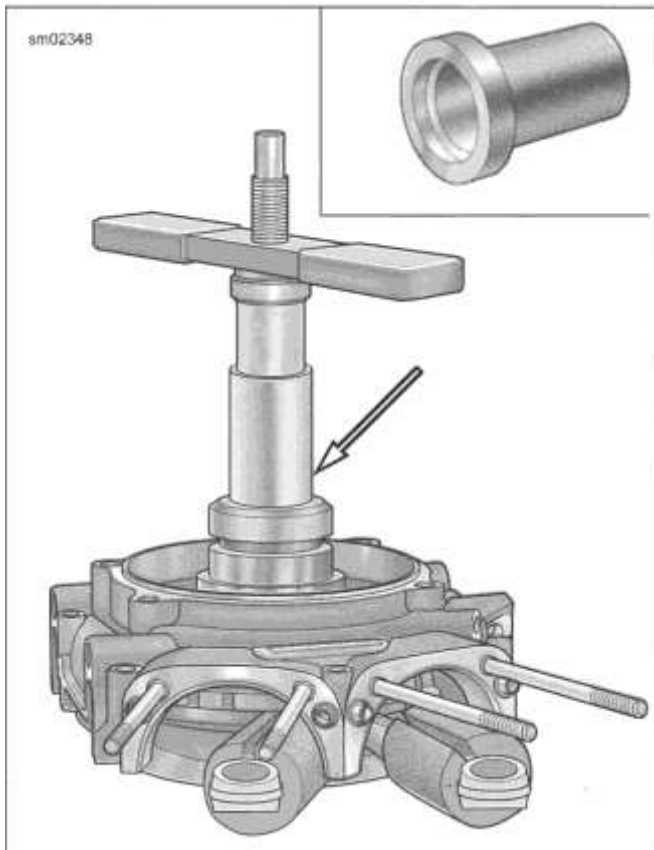


Figure 4-65. Sprocket Shaft Oil Seal Installer

**REPAIR\_RIGHTCRANKCASE\_HALF**

| PART NUMBER | TOOL NAME                          |
|-------------|------------------------------------|
| HD-52071    | MAIN BEARING REMOVER AND INSTALLER |

| FASTENER               | TORQUE VALUE  |             |
|------------------------|---------------|-------------|
| Balancer bearing screw | 80-110 in-lbs | 9-12.4 N-m  |
| Piston jet screws      | 25-35 in-lbs  | 2.8-3.9 N-m |

| PART NUMBER | CONSUMABLE                                    |
|-------------|---|
| 99811-97    | LOCTITE 222 LOW STRENGTH THREADLOCKER(PURPLE) |

**Remove Main Bearing**

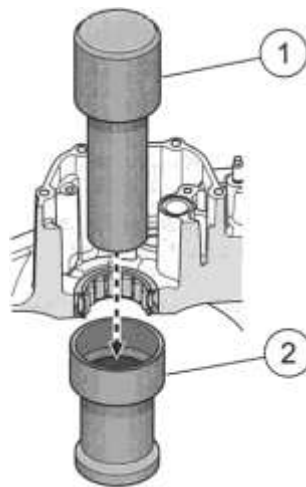
- NOTE  
Never move or lift crankcase by grasping cylinder studs.

See Figure 4-66. Remove bearing.  
Special Tool: MAIN BEARING REMOVER AND INSTALLER (HD-52071)

- Press bearing from cam side into flywheel side of crankcase.

- Discard bearing.

355319

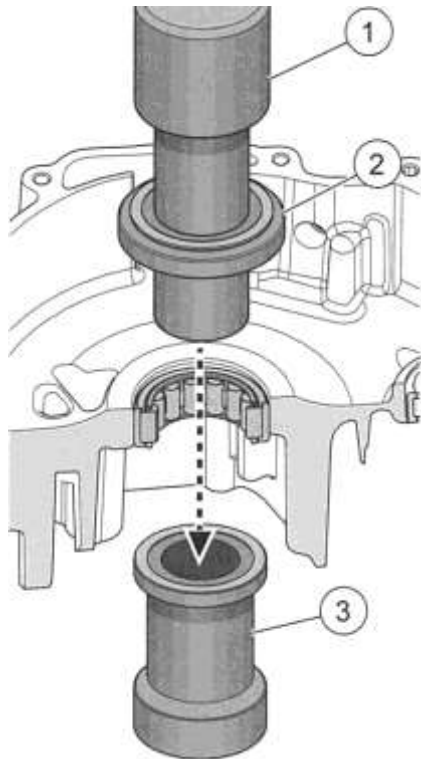


- Main bearing arbor
- Bearing support

Figure 4-66. Remove Right Main Bearing

**Install Main Bearing**

- See Figure 4-67. Install bearing.  
Special Tool: MAIN BEARING REMOVER AND INSTALLER (HD-52071)
  - Place crankcase with flywheel side facing up on main bearing support (3).
  - Spread clean engine oil on OD of new bearing (5).
  - Place bearing on bearing bore with lettering facing up.
  - Place main bearing installer (2) with side marked RIGHT against bearing.
  - Place main bearing arbor (1) through main bearing installer and bearing into bearing support.
  - Press until main bearing installer contacts machined surface.
- Check installed depth. Refer to Table 4-35.



1. Main bearing arbor
2. Main bearing installer
3. Bearing support
4. Press ram
5. Main bearing

Figure 4-67. Right Main Bearing Installation

Table 4-35. Right Crankcase Bearing Installed Depth

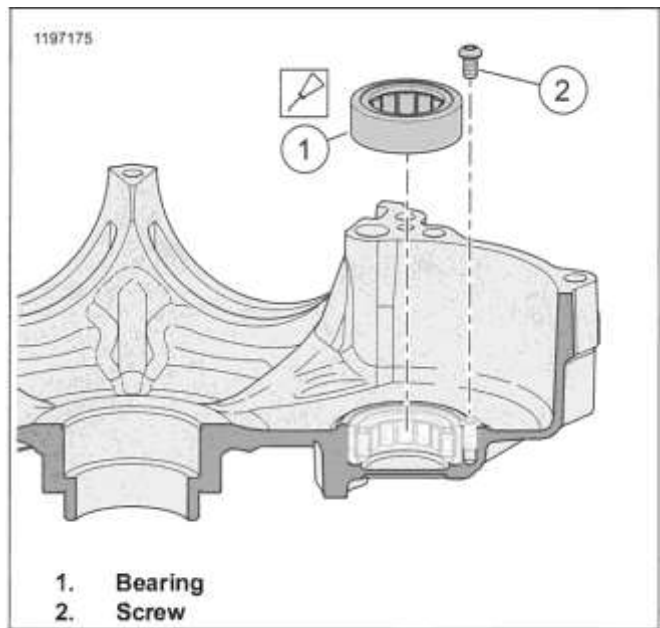
| BEARING LOCATION    | DEPTH from SPLIT LINE           |
|---------------------|---------------------------------|
| Right side main     | 2.160-2.180 in (54.86-55.37 mm) |
| Right side balancer | 2.070-2.090 in (52.58-53.09 mm) |

### Remove Balancer Bearing

1. See Figure 4-68. Remove retaining screw (2).
2. **NOTE**  
*Non-open flame heat may be applied to vicinity of bearing to assist in removal.*

Use appropriate puller to remove bearing (1) from bore.

3. Discard bearing.



1. Bearing
2. Screw

Figure 4-68. Balancer Bearing (typical)

### Install Balancer Bearing

1. Apply engine oil to OD of **new** bearing.
2. **NOTE** *Install bearings with lettering facing up.*  
*Properly support area of crankcase where bearing is being installed.*  
*Do not use screw to draw bearing in.*

Using a press, install **new** bearing until fully seated in bore.

3. Install retaining screw. Tighten.  
Torque: 80-110 **in-lbs** (9-12.4 N-m) *Balancer bearing screw*

### Remove Piston Jets

1. See Figure 4-69. Remove screws (3) to free piston jet (2) from crankcase.
2. Discard gasket (1).

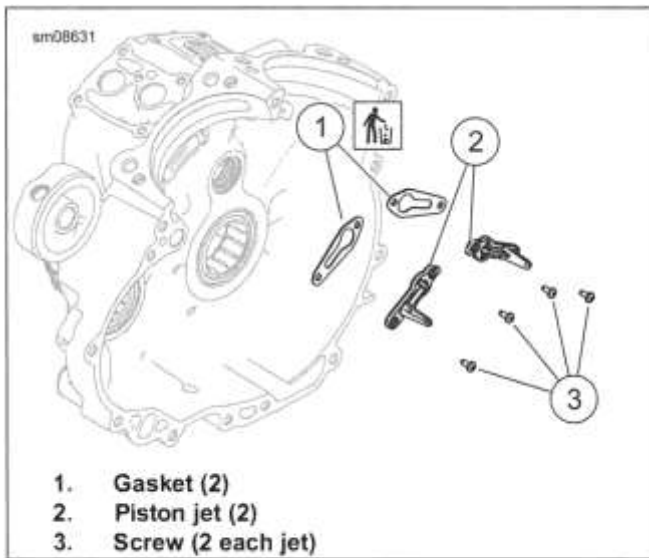


Figure 4-69. Piston Jets

### Install Piston Jets

- NOTE

If piston jet screws are being reused, apply threadlocker to screws. **LOCTITE 222 LOW STRENGTH THREADLOCKER (PURPLE) (99811-97)**

See Figure 4-69. Install piston jets.

- Install new gasket (1).
- With jet pointed up, secure piston jet (2) and gasket with screws (3).
- Tighten. 25-35 in-lbs (2.8-3.9 N-m).

### REPAIR LEFT CRANKCASE HALF

| PART NUMBER | TOOL NAME                          |
|-------------|------------------------------------|
| HD-52071    | MAIN BEARING REMOVER AND INSTALLER |

| FASTENER               | TORQUE VALUE  |            |
|------------------------|---------------|------------|
| Balancer bearing screw | 80-110 in-lbs | 9-12.4 N-m |

### Remove Main Bearing

#### A CAUTION

Do not rotate crankcase half in engine stand when flywheel is installed. The flywheel assembly can fall out, resulting in parts damage or moderate injury. (00552c)

- NOTE

• Never move or lift crankcase by grasping cylinder studs. Always replace sprocket shaft bearing inner race whenever left main bearing is replaced. See *Sprocket Shaft Bearing Inner Race (Page 4-69)*.

Remove thrust washer from outboard side of crankcase half by pulling it past oil seal. Set thrust washer aside for inspection or reuse.

- Remove oil seal.

- Remove bearing.

Special Tool: MAIN BEARING REMOVER AND INSTALLER (HD-52071)

- See Figure 4-70. Remove bearing retaining ring.
- See Figure 4-71. Press bearing from stator side into flywheel side of crankcase.

- Discard bearing.

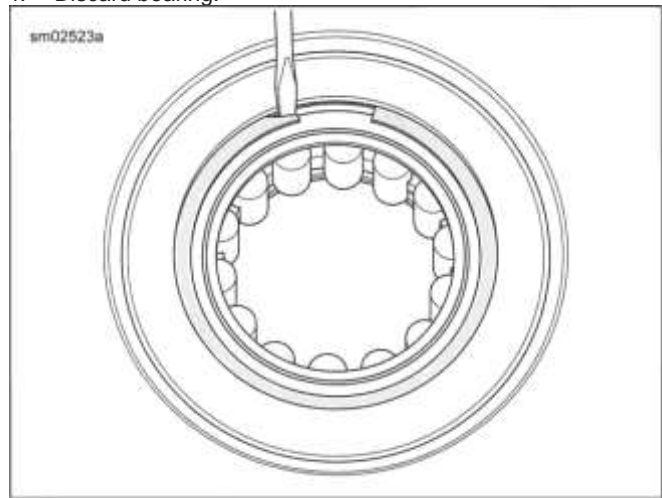


Figure 4-70. Remove Retaining Ring

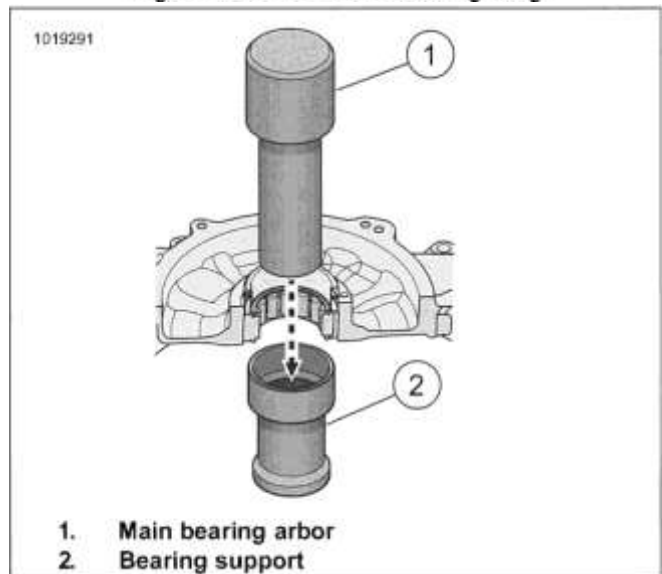


Figure 4-71. Remove Left Main Bearing **Install Main**

### Bearing

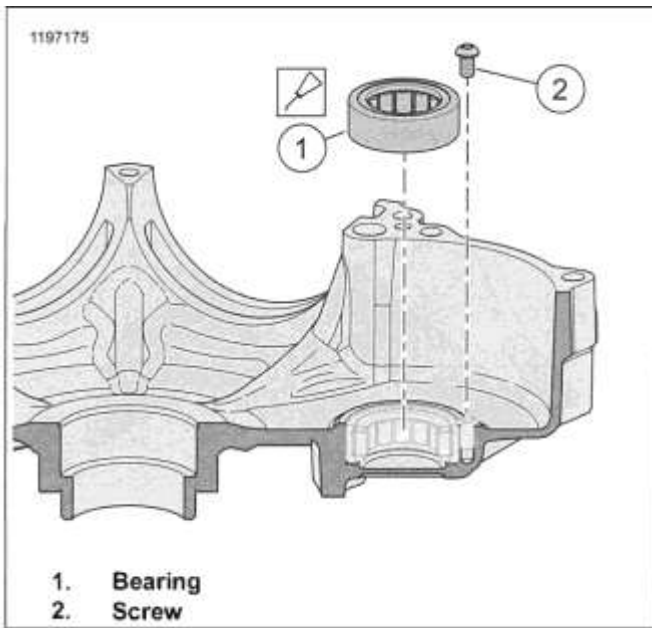
- NOTE

Alternator stator may be left installed when main bearing press adapter is used.

See Figure 4-72. Install bearing.

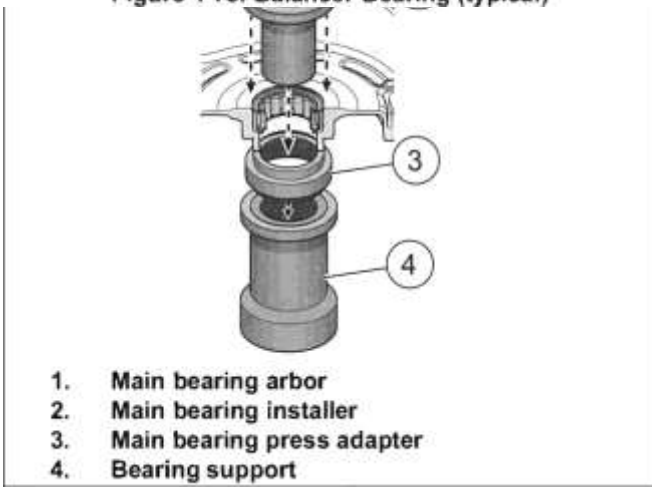
Special Tool: MAIN BEARING REMOVER AND INSTALLER (HD-52071)

- Place main bearing press adapter (3) on bearing support (4).
- Place crankcase on main bearing press adapter (3) with flywheel side facing up.



1. Bearing
2. Screw

Figure 4-73. Balancer Bearing (typical)



1. Main bearing arbor
2. Main bearing installer
3. Main bearing press adapter
4. Bearing support

Figure 4-72. Install Left Main Bearing

### Remove Balancer Bearing

1. See Figure 4-73. Remove retaining screw (2).
2. 

*NOTE*

*Non-open flame heat may be applied to vicinity of bearing to assist in removal.*  
  
Use appropriate puller to remove bearing (1) from bore.
3. Discard bearing.

### Install Balancer Bearing

1. Apply engine oil to OD of new bearing.
2. 

*NOTE*

*Install bearings with lettering facing up.*  
  
*Properly support area of crankcase where bearing is being installed.*

Using a press, install new bearing until fully seated in bore.

3. Install retaining screw. Tighten.  
Torque: 80-110 in-lbs (9-12.4 N-m) *Balancer bearing screw*

### SPROCKET SHAFT BEARING INNER RACE

| PART NUMBER   | TOOL NAME   |
|---------------|---|
| HD-25070      | ROB I NAIR HEAT GUN   |
| HD-34902-B    | BIG-TWIN MAINSHAFT PRIMARY BEARING RACE REMOVER AND INSTALLER |
| HD-44358      | FLYWHEEL SUPPORT FIXTURE                                      |
| H D-95637-46B | WEDGE ATTACHMENT  |
| HD-97225-55C  | SPROCKET SHAFT BEARING INSTALLER                              |

### Remove

1. 

*NOTE*

*For proper clamping force, hold-down clamp must not be tilted. Rotate hex on outboard stud until clamp is level.*

See Figure 4-74. Secure flywheel assembly.

Special Tool: FLYWHEEL SUPPORT FIXTURE (HD-44358)

- a. Secure fixture in vise.
- b. Insert crankshaft end through hole, resting flywheel assembly on fixture.

- c. Engage knurled locating pin in crank pin hole.
- d. Hand-tighten locating pin.

- e. Secure flywheel with hold-down clamps (2).

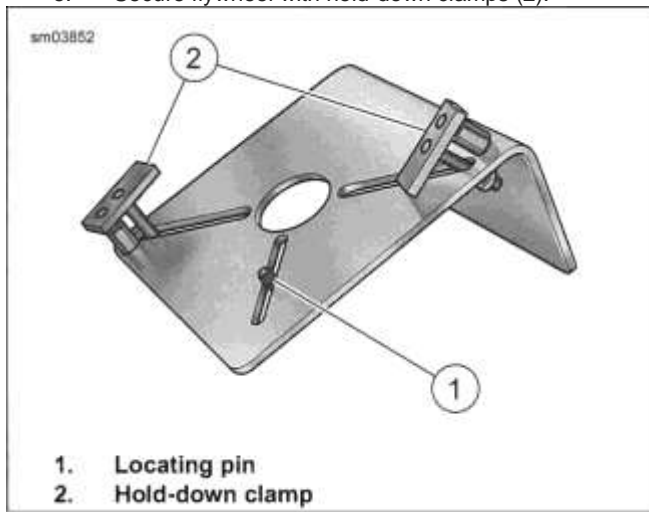


Figure 4-74. Flywheel Holding Fixture

**NOTICE**

Install wedge attachment only so far as necessary to ensure positive contact with bearing inner race. Installing tool with more contact than necessary will result in damage to the flywheel (00500b)

- 2. See Figure 4-75. Install pulling tool.
  - a. Position wedge attachment (5) on inboard side of thrust washer.
 

Special Tool: WEDGE ATTACHMENT (HD-95637-46B)
  - b. Draw wedge halves together evenly.
  - c. Secure bridge and forcing screw from bearing race remover and installer to wedge attachment with flat washers and two 3/8-16 x 7-1/2 in bolts.
 

Special Tool: BIG-TWIN MAINSHAFT PRIMARY BEARING RACE REMOVER AND INSTALLER (HD-34902-B)
  - d. Place hardened washer between end of sprocket shaft and forcing screw.

**A WARNING**

Do not use heating devices with penetrating oil. Penetrating oil is flammable which could result in death or serious injury. (00375a)

- 3. **NOTE**  
*To assist removal without heat, apply light penetrating oil to shaft and leading edge of bearing inner race.*

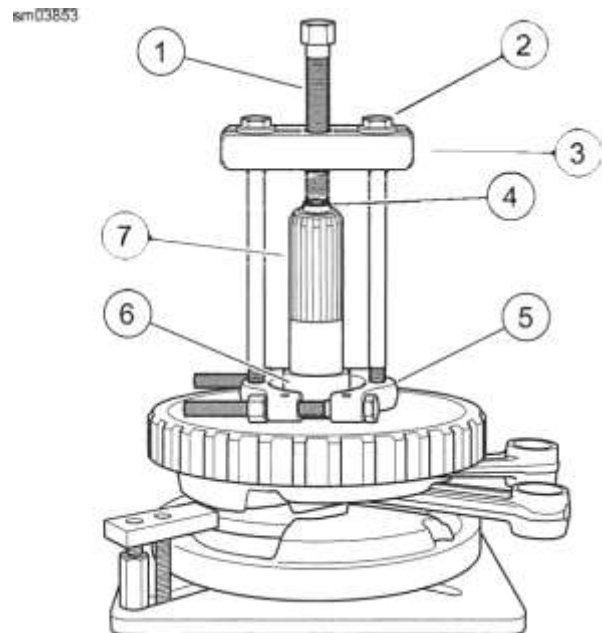
Uniformly heat bearing inner race for approximately 30 seconds using heat gun.

Special Tool: ROBINAIR HEAT GUN (HD-25070)

- 4. See Figure 4-75. Remove bearing race.
  - a. Turn forcing screw until thrust washer and bearing inner race move minimum distance.
    - o. 1/16 in (3.2 mm)
  - b. Reposition attachment to pull on bearing inner race only.
 

Special Tool: WEDGE ATTACHMENT (HD-95637-46B)
  - c. Verify tool assembly is square.
  - d. Heat bearing inner race for approximately 30 seconds.
  - e. Turn forcing screw until bearing inner race is loose.
  - f. Remove thrust washer from sprocket shaft.

Figure 4-75. Remove Inner Race from Sprocket Shaft



**Y**

- 1. Forcing screw
- 2. 3/8-16 bolt with flat washer
- 3. Bridge
- 4. Hardened washer
- 5. Wedge attachment
- 6. Bearing inner race
- 7. Sprocket shaft

**Install**

- 1. Place new thrust washer over sprocket shaft.

**A WARNING**

Do not use heating devices with penetrating oil. Penetrating oil is flammable which could result in death or serious injury. (00375a)

- 2. **NOTE**  
*To assist installation without heat, apply light penetrating oil to shaft and leading edge of bearing inner race.*



Uniformly heat new bearing for approximately 60 seconds using heat gun.

Special Tool: ROBINAIR HEAT GUN (HD-25070)

3. Place bearing inner race squarely over sprocket shaft.
4. See Figure 4-76. Seat bearing race using installer.

Special Tool: SPROCKET SHAFT BEARING INSTALLER (HD-97225-55C)

5. Verify thrust washer cannot be rotated by hand.



Figure 4-76. Press Inner Race onto Sprocket Shaft: Operation

## CYLINDER STUDS

| FASTENER      | TORQUE VALUE  |                |
|---------------|---------------|----------------|
| Cylinder stud | 120-240in-lbs | 13.6--27.1 N-m |

### Remove

1. Tighten two nuts together on threads of stud.
2. Place wrench on lower nut. Turn to remove stud.

### Install

1. Place a steel ball inside a cylinder head screw.
2. Put head screw on long end of cylinder stud.
3. Install stud using air gun until collar reaches crankcase.
4. Tighten.  
Torque: 120-240 in-lbs (13.6-27.1 N-m) *Cylinder stud*
5. Remove cylinder head screw using air gun.

## PLUGS AND OIL FITTINGS

| FASTENER                                      | TORQUE VALUE   |               |
|---|----------------|---------------|
| Crankcase oil check valve or plug with O-ring | 18-22 ft-lbs   | 24.4-29.8 N-m |
| Crankcase tapered plugs                       | 120-144 in-lbs | 13.6-16.3 N-m |

| PART NUMBER | CONSUMABLE                 |
|-------------|----------------------------|
| 99818-97    | LOCTITE 565 THREAD SEALANT |

### Remove

See Figure 4-77. Turn pipe plug or oil check valve counterclockwise to remove.

### Install

1. See Figure 4-77. Install tapered plug (1).
  - a. Apply thread sealant to threads.  
LOCTITE 565 THREAD SEALANT (99818-97)
  - b. Install and tighten.  
Torque: 120-144 in-lbs (13.6-16.3 N-m) *Crankcase tapered plugs*
2. Install oil check valve (2) or plug with O-ring (3). a. Install new O-ring.
  - b. Install and tighten.  
Torque: 18-22 ft-lbs (24.4-29.8 N-m) *Crankcase oil check valve or plug with O-ring*

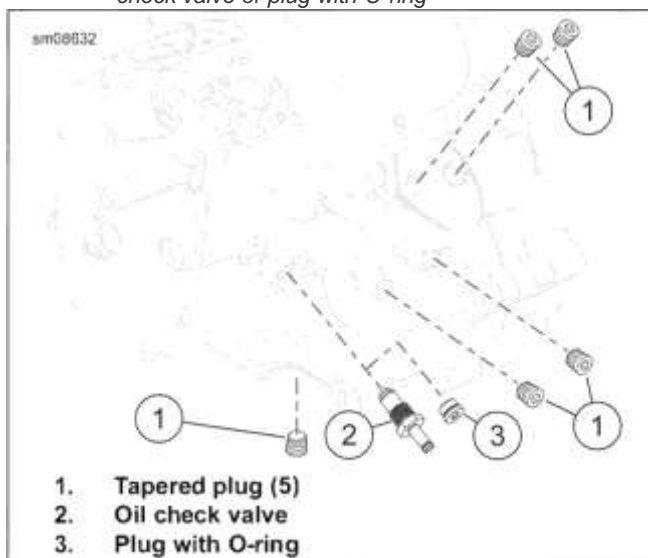


Figure 4-77. Crankcase Pipe Plugs

## COMPLETE

1. Install pistons. See PISTONS (Page 4-46).
2. Install cylinders. See CYLINDERS (Page 4-42).
3. Install cylinder heads. See CYLINDER HEADS (Page 4-36).
4. Install pushrods. See PUSHRODS, LIFTERS AND COVERS (Page 4-32).
5. Install rocker arms. See ROCKER ARMS (Page 4-30).
6. Install lower rocker covers. See LOWER ROCKER COVERS (Page 4-28).
7. Install breathers. See BREATHERS (Page 4-26).



8. Install upper rocker covers. See UPPER ROCKER COVERS (Page 4-24).

9. Install engine. See REPLACE ENGINE (Page 4-61).



**SYMPTOMS****Overview**

Flywheels that shift out of true at the crank pin generally exhibit one of two symptoms: no oil pressure or vibration. This condition is also known as scissored flywheels.

**No Oil Pressure**

Oil pump damage may occur when flywheels shift more than 0.015 in (0.381 mm).

If a low or no oil pressure condition is confirmed, inspect oil pump and cam support plate. Bound or damaged oil pump gerotors are likely from a contaminant running through the pump or a shifted/scissored flywheels. If this type of damage is found, always replace oil lines and clean all debris from entire lubrication system. For general diagnostics of low oil pressure, see TROUBLESHOOTING (Page 2-54).

**Vibration**

Vibration caused by flywheel/connecting rod assembly runout becomes noticeable to rider after runout exceeds 0.020 in (0.508 mm).

See TROUBLESHOOTING (Page 2-54).

When correct chassis set-up has been verified and other items have been eliminated, checking left crankshaft runout is appropriate. See TROUBLESHOOTING (Page 4-12).

**PREPARE**

1. Remove engine. See REPLACE ENGINE (Page 4-61).

2. **NOTE**  
*Abrasive particles can damage machined surfaces or plug oil passageways. Clean parts before disassembly to prevent component damage.*

Use low-pressure compressed air to clean exterior surfaces of engine.

3. Remove upper rocker covers. See UPPER ROCKER COVERS (Page 4-24).

4. Remove breathers. See BREATHERS (Page 4-26).

5. Remove lower rocker covers. See LOWER ROCKER COVERS (Page 4-28).

6. Remove rocker arms. See ROCKER ARMS (Page 4-30).

7. Remove pushrods. See PUSHRODS, LIFTERS AND COVERS (Page 4-32).

8. Remove cylinder heads. See CYLINDER HEADS (Page 4-36).

9. Remove cylinders. See CYLINDERS (Page 4-42).

10. Remove pistons. See PISTONS (Page 4-46).

11. Separate crankcase halves. See CRANKCASE (Page 4-63).

**INSPECT****NOTE**

- Do not attempt to straighten connecting rods. Damage to upper bushing and lower bearing will occur.
- Zones of resistance when connecting rods are rotated through their range of motion alone is not an indication of a performance or durability concern. Connecting rod bearing failures generally exhibit noise, visible clearance, piston to valve contact, and/or secondary damage in the form of a high level of steel debris circulating throughout the engine. Verify that one or more of these symptoms is present before attempting to qualify the rod bearing condition.
- Connecting rods when placed in limit conditions, defined as positions outside the normal rod operating position (pinched together or spread to the extent of separation), may exhibit areas of resistance.
- The induction heat treat operation on Milwaukee-Eight® connecting rods will "blue" the lower end of the rod. "Blueing" on the lower rod end only is normal.

1. Inspect flywheel/connecting rod assembly if any of the following are evident.

**NOTE**

Replace assembly if any of the following conditions are noted.

- a. Rod knock noise
  - b. Steel debris in oil filter
  - c. Piston skirt scoring/scuffing
  - d. Worn oil pump scavenge rotor and housing
  - e. Piston to valve contact
  - f. Damage to flywheel left or right main bearing inner races
  - g. Bent or twisted connecting rods
  - h. Sprocket teeth are worn in an irregular pattern or chipped
  - i. Main bearing inner races are brinelled, burnt, scored, blued or damaged
  - j. Flywheel, connecting rods or right side bearing inner race require replacement
2. Measure crankshaft runout if crankshaft is suspected of being out-of-true. See TROUBLESHOOTING (Page 4-12).

## **COMPLETE**

1. Install flywheel and connecting rods. Assemble crankcase. See CRANKCASE (Page 4-63).
2. Install pistons. See PISTONS (Page 4-46).
3. Install cylinders. See CYLINDERS (Page 4-42).
4. Install cylinder heads. See CYLINDER HEADS (Page 4-36).
5. Install pushrods. See PUSHRODS, LIFTERS AND COVERS (Page 4-32).
6. Install rocker arms. See ROCKER ARMS (Page 4-30).
7. Install lower rocker covers. See LOWER ROCKER COVERS (Page 4-28).
8. Install breathers. See BREATHERS (Page 4-26).
9. Install upper rocker covers. See UPPER ROCKER COVERS (Page 4-24).
10. Install engine. See REPLACE ENGINE (Page 4-61 ).

**PREPARE**

1. Position motorcycle on a lift.
2. Drain engine oil. See REPLACE ENGINE OIL AND FILTER (Page 2-9).
3. Drain transmission lubricant. See REPLACE TRANSMISSION LUBRICANT (Page 2-13).
4. Remove the left muffler, exhaust cross-over pipe and cross-over pipe clamp bracket from the transmission. See EXHAUST SYSTEM (Page 6-34).
5. Remove rear wheel. See REAR WHEEL (Page 3-14).

**REMOVE**

1. Remove engine oil fill plug/dipstick.
2. See Figure 4-78. Remove oil pan.
  - a. Remove 12 screws (4).
  - b. Slide oil pan (2) rearward to remove.
  - c. Discard oil pan gasket (1).
  - d. If necessary, remove tapered plug (3).
3. **NOTE**  
*Debris that remains in the pan can cause a repeat failure. Install a new oil pan if necessary.*  
  
 Thoroughly inspect and clean oil pan.
4. If debris is found, replace oil pan, inspect oil coolers, check valves and oil filter. Clean or replace as necessary.

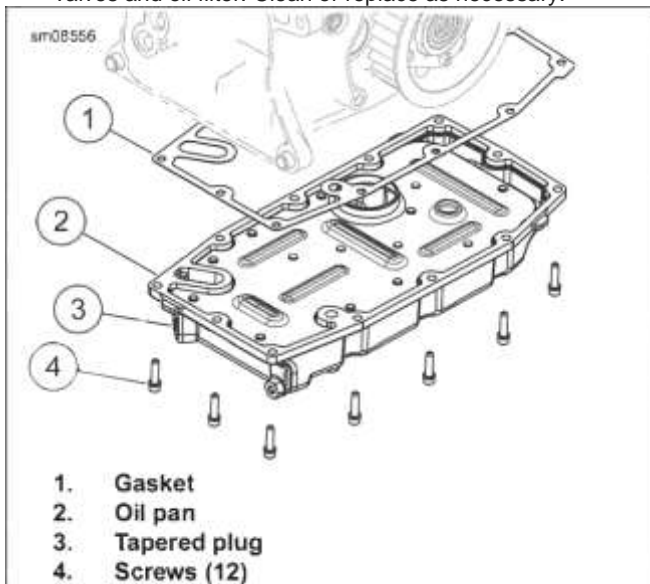


Figure 4-78. Oil Pan Assembly

2. Clean engine oil and transmission lubricant drain plugs. a. Replace O-rings as required.

**INSTALL**

| FASTENER                | TORQUE VALUE   |                |
|-------------------------|----------------|----------------|
| Engine oil drain plug   | 14-21 ft-lbs   | 19-28.5 N-m    |
| Oil pan fasteners       | 132-156 in-lbs | 14.9-17.6 N-m  |
| Oil pan tapered plug    | 30-36 ft-lbs   | 40.7--48.8 N-m |
| Transmission drain plug | 14-21 ft-lbs   | 19-28.5 N-m    |

| PART NUMBER | CONSUMABLE  |
|-------------|---|
| 99642-97    | LOCTITE 243 MEDIUM STRENGTH THREADLOCKER AND SEALANT (BLUE) |
| 99653-85    | HYLOMAR GASKET AND THREAD SEALANT                           |
| 99818-97    | LOCTITE 565 THREAD SEALANT                                  |

1. Clean and examine all flange surfaces.
3. Install transmission drain plug and O-ring. Tighten.  
 Torque: 14-21 ft-lbs (19-28.5 N-m) *Transmission drain plug*
4. Install engine oil drain plug and O-ring. Tighten.  
 Torque: 14-21 ft-lbs (19-28.5 N-m) *Engine oil drain plug*
5. See Figure 4-78. If removed, install tapered plug (3).
  - a. Apply thread sealant.  
 LOCTITE 565 THREAD SEALANT (99818-97)
  - b. Install and tighten.  
 Torque: 30-36 ft-lbs (40.7--48.8 N-m) *Oil pan tapered plug*
6. Install oil pan.
  - a. Apply thin coat of sealant to oil pan flange.  
 HYLOMAR GASKET AND THREAD SEALANT (99653-85)
  - b. Apply threadlocker to used oil pan screws.  
 LOCTITE 243 MEDIUM STRENGTH THREADLOCKER AND SEALANT (BLUE) (99642-97)
  - c. Place new gasket (1) on oil pan flange. Allow sealant to dry until tacky.
  - d. Position oil pan with gasket on bottom of transmission.
  - e. Loosely install fasteners (4).

- f. See Figure 4-79. Tighten fasteners in sequence shown.

Torque: 132-156 **in-lbs** (14.9-17.6 N-m) *Oil pan*

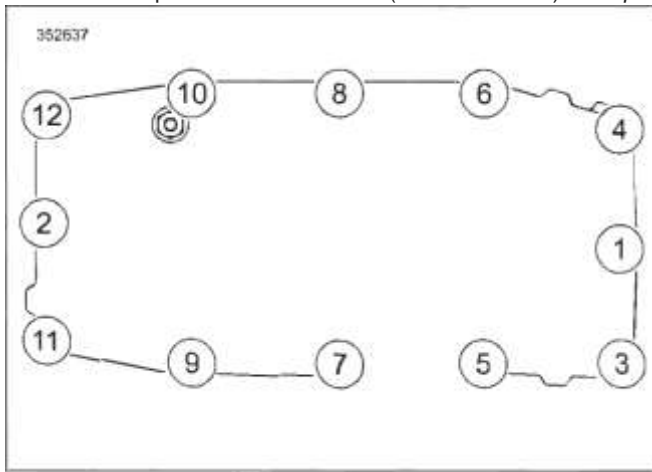


Figure 4-79. Oil Pan Tightening Sequence

*fasteners*

## **COMPLETE**

1. Install rear wheel. See REAR WHEEL (Page 3-14).
2. Install exhaust. See EXHAUST SYSTEM (Page 6-34).
3. Add fluids.
  - a. Add transmission lubricant. See REPLACE TRANSMISSION LUBRICANT (Page 2-13).
  - b. Install **new** engine oil filter.
  - c. Fill engine oil. See REPLACE ENGINE OIL AND FILTER (Page 2-9).





| SUBJECT                                      | PAGE NO. |
|--|----------|
| 5.1 FASTENER TORQUE VALUES .....             | 5-1      |
| 5.2 SPECIFICATIONS .....                     | 5-2      |
| 5.3 TRANSMISSION OPERATION .....             | 5-4      |
| 5.4 DRIVE BELT .....                         | 5-6      |
| 5.5 SHIFTER LINKAGE .....                    | 5-7      |
| 5.6 CLUTCH RELEASE COVER .....               | 5-9      |
| 5.7 CLUTCH RELEASE PUSH ROD COMPONENTS ..... | 5-12     |
| 5.8 PRIMARY CHAINCASE COVER .....            | 5-14     |
| 5.9 DRIVE COMPONENTS .....                   | 5-16     |
| 5.10 CLUTCH .....                            | 5-20     |
| 5.11 PRIMARY CHAINCASE HOUSING .....         | 5-25     |
| 5.12 TRANSMISSION SPROCKET .....             | 5-29     |
| 5.13 TRANSMISSION .....                      | 5-32     |
| 5.14 MAIN DRIVE GEAR AND BEARING .....       | 5-42     |
| 5.15 TRANSMISSION CASE .....                 | 5-47     |

## NOTES



**FASTENER TORQUE VALUES IN THIS CHAPTER**

| FASTENER                                     | TORQUE VALUE          |                 | NOTES   |
|--|-----------------------|-----------------|---|
|  |                       |                 |   |
| Battery ground cable to transmission         | 66-114 in-lbs         | 7.5-12.9 N-m    | 5.15 TRANSMISSION CASE, Install   |
| Clutch cable fitting                         | 90-120 in-lbs         | 10.2-13.6 N-m   | 5.6 CLUTCH RELEASE COVER, Install   |
| Clutch hub mainshaft nut                     | 70-80 ft-lbs          | 94.9-108.5 N-m  | 5.9 DRIVE COMPONENTS, Install   |
| Clutch release cover screws                  | 132-156 in-lbs        | 14.9-17.6 N-m   | 5.6 CLUTCH RELEASE COVER, Install   |
| Compensating sprocket bolt, 1st torque       | <b>100</b> ft-lbs     | 135.6 N-m       | 5.9 DRIVE COMPONENTS, Install<br>Loosen then final tighten                      |
| Compensating sprocket bolt, final torque     | 175 ft-lbs            | 237.3 N-m       | 5.9 DRIVE COMPONENTS, Install   |
| Oil return tube screw                        | <b>100-120</b> in-lbs | 11.3-13.6 N-m   | 5.15 TRANSMISSION CASE, Assemble  |
| Primary chaincase sealing screws             | 26-28 ft-lbs          | 35.3-38 N-m     | 5.11 PRIMARY CHAINCASE HOUSING, Install   |
| Primary chain tensioner fasteners            | 21-24 ft-lbs          | 28.5-32.6 N-m   | 5.9 DRIVE COMPONENTS, Install   |
| Primary cover screws                         | 144-156 in-lbs        | 16.3-17.6 N-m   | 5.8 PRIMARY CHAINCASE COVER, Install<br>See sequence in the procedure           |
| Shift drum detent screw                      | 120-150 in-lbs        | 13.6-17 N-m     | 5.13 TRANSMISSION, Assemble   |
| Shift drum lock plate screws                 | 57-63 in-lbs          | 6.4-7.1 N-m     | 5.13 TRANSMISSION, Assemble   |
| Shifter pawl centering screw                 | 18-23 ft-lbs          | 24.4-31.2 N-m   | 5.15 TRANSMISSION CASE, Assemble  |
| Shifter peg screw                            | 96-144 in-lbs         | 10.9-16.3 N-m   | 5.5 SHIFTER LINKAGE, Foot Shift Lever   |
| Shifter rod jamnut                           | 80-120 in-lbs         | 9-13.6 N-m      | 5.5 SHIFTER LINKAGE, Shifter Rod  |
| Shifter rod lever pinch screw                | 18-22 ft-lbs          | 24.4-29.8 N-m   | 5.15 TRANSMISSION CASE, Assemble  |
| Shifter rod lever pinch screw, front lever   | 132-156 in-lbs        | 14.9-17.6 N-m   | 5.5 SHIFTER LINKAGE, Shifter Rod Lever, Front                                   |
| Shifter rod nut                              | <b>8-12</b> ft-lbs    | 11-16 N-m       | 5.5 SHIFTER LINKAGE, Shifter Rod  |
| Shifter rod nut                              | <b>8-12</b> ft-lbs    | 11-16 N-m       | 5.5 SHIFTER LINKAGE, Shifter Rod  |
| Shifter rod nut                              | <b>8-12</b> ft-lbs    | 11-16 N-m       | 5.5 SHIFTER LINKAGE, Shifter Rod Lever, Front                                   |
| Shift lever pinch screw                      | 9.0-12.0 ft-lbs       | 12.2-16.3 N-m   | 5.5 SHIFTER LINKAGE, Foot Shift Lever   |
| Transmission bearing housing screw           | 22-25 ft-lbs          | 29.8-33.9 N-m   | 5.13 TRANSMISSION, Install  |
| Transmission mainshaft/countershaft locknuts | 85-95 ft-lbs          | 115.3-128.8 N-m | 5.13 TRANSMISSION, Assemble   |
| Transmission mounting bolts, 1st torque      | 15 ft-lbs             | 20.3 N-m        | 5.15 TRANSMISSION CASE, Install   |
| Transmission mounting bolts, final torque    | 34-39 ft-lbs          | 46.1-52.9 N-m   | 5.15 TRANSMISSION CASE, Install   |
| Transmission sprocket lockplate screws       | 90-120 in-lbs         | 10.2-13.6 N-m   | 5.12 TRANSMISSION SPROCKET, Install<br>Lock patch, use 3-5 times                |
| Transmission sprocket nut, 1st torque        | <b>100</b> ft-lbs     | 135.6 N-m       | 5.12 TRANSMISSION SPROCKET, Install   |
| Transmission sprocket nut, 2nd torque        | 35 ft-lbs             | 47.5 N-m        | 5.12 TRANSMISSION SPROCKET, Install plus 35-40 degrees                          |
| Transmission sprocket nut, final torque      |                       | 35-40°          | 5.12 TRANSMISSION SPROCKET, Install<br>Do not loosen to align lockplate screws. |
| Transmission top cover screw                 | 132-156 in-lbs        | 14.9-17.6 N-m   | 5.13 TRANSMISSION, Install  |

**DRIVE SPECIFICATIONS**

FORMULA+ TRANSMISSION AND PRIMARY CHAINCASE LUBRICANT and SCREAMIN' EAGLE SYN3 FULL SYNTHETIC MOTORCYCLE LUBRICANT 20W50 are both acceptable lubricants.

**Table 5-1. Primary Chaincase Lubricant**

| ITEM    | DRY FILL** |     | WET FILL*** |     |
|---------|------------|-----|-------------|-----|
|         | Oz         | L   | Oz          | L   |
| Amount* | 34         | 1.0 | 30          | 0.9 |

\* Amount is approximate. Fill to bottom of pressure plate OD with vehicle upright.

\*\* Cover was removed and installed.

\*\*\* Lubricant was drained through the drain plug only.

**Table 5-2. Sprocket Teeth**

| DRIVE   | ITEM         | NUMBER OF TEETH |
|---------|--------------|-----------------|
| Primary | Engine       | 34              |
|         | Clutch       | 46              |
| Final   | Transmission | 32              |
|         | Rear wheel   | 68              |

**Table 5-3. Overall Drive Ratios**

| GEAR   | RATIO |
|--------|-------|
| First  | 9.593 |
| Second | 6.650 |
| Third  | 4.938 |
| Fourth | 4.000 |
| Fifth  | 3.407 |
| Sixth  | 2.875 |

**NOTE**

Overall gear ratios indicate number of engine revolutions required to drive rear wheel one revolution.

**TRANSMISSION SPECIFICATIONS**

**Table 5-4. Transmission Specifications**

| TRANSMISSION  | DATA                          |
|---|-------------------------------|
| Type  | 6-speed forward constant mesh |
| FORMULA+ TRANSMISSION AND PRIMARY CHAINCASE LUBRICANT | Part No. 99851-05 (qt)        |
| SYN3 20W50 Oil  | Part No. 99824-03/00QT (qt)   |
| Capacity * ( approximate)                             | 28 fl oz (0.83 L)             |

\* Add additional fluid as necessary to bring level within specification.

**Table 5-5. Transmission Gear Ratios**

| GEAR         | GEAR RATIO |
|--------------|------------|
| First (low)  | 3.34       |
| Second       | 2.31       |
| Third        | 1.72       |
| Fourth       | 1.39       |
| Fifth        | 1.19       |
| Sixth (high) | 1.00       |

**NOTE**

Final gear ratios indicate the number of mainshaft revolutions required to drive the output sprocket one revolution.

**SERVICE WEAR LIMITS**

**Table 5-6. Main Drive Gear Specifications**

| MAIN DRIVE GEAR (sixth)                  | IN            | MM           |
|--|---------------|--------------|
| Bearing fit in transmission case (loose) | 0.0003-0.0017 | 0.0076-0.043 |
| Fit in bearing (press-fit)               | 0.001-0.003   | 0.025-0.076  |
| End play: Two row bearing                | none          | none         |
| End play: Single row bearing             | 0.000-0.012   | 0.000-0.305  |

**Table 5-7. Mainshaft Tolerance Specifications**

| MAINSHAFT TOLERANCE           | IN            | MM          |
|-------------------------------|---------------|-------------|
| Mainshaft runout              | 0.000-0.003   | 0.00-0.08   |
| Mainshaft end play            | none          | none        |
| Fifth gear end play (axial)   | 0.002-0.026   | 0.05-0.66   |
| Fifth gear clearance (radial) | 0.0004-0.0020 | 0.009-0.052 |
| Main drive gear (sixth) fit   | 0.0009-0.0022 | 0.023-0.056 |

**Table 5-8. Countershaft Tolerance Specifications**

| COUNTERSHAFT TOLERANCE         | IN            | MM          |
|--------------------------------|---------------|-------------|
| Countershaft runout            | 0.000-0.003   | 0.00-0.08   |
| Countershaft end play          | 0.001-0.003   | 0.025-0.08  |
| First gear end play (axial)    | 0.001-0.023   | 0.03-0.58   |
| First gear clearance (radial)  | 0.0004-0.0020 | 0.010-0.052 |
| Second gear end play (axial)   | 0.001-0.40    | 0.03-1.02   |
| Second gear clearance (radial) | 0.0004-0.0020 | 0.010-0.052 |
| Third gear end play (axial)    | 0.001-0.042   | 0.03-1.07   |
| Third gear clearance (radial)  | 0.0004-0.0020 | 0.010-0.052 |
| Fourth gear end play (axial)   | 0.001-0.028   | 0.03-0.71   |
| Fourth gear clearance (radial) | 0.0004-0.0020 | 0.010-0.052 |

**Table 5-9. Shifter Dog Clearance Specifications**

| SHIFTER DOG | IN          | MM        |
|-------------|-------------|-----------|
| First       | 0.013-0.121 | 0.33-3.07 |
| Second      | 0.016-0.138 | 0.41-3.51 |
| Third       | 0.010-0.125 | 0.25-3.17 |
| Fourth      | 0.018-0.129 | 0.46-3.28 |
| Fifth       | 0.007-0.117 | 0.18-2.97 |
| Sixth       | 0.022-0.131 | 0.56-3.33 |

**Table 5-10. Bearing Housing Bearing Specifications**

| BEARING HOUSING BEARING        | IN            | MM            |
|--------------------------------|---------------|---------------|
| Fit in bearing housing (tight) | 0.0001-0.0014 | 0.0025-0.0356 |
| Fit on countershaft (tight)    | -0.0004       | -0.010        |
| Fit on countershaft (loose)    | +0.0012       | +0.030        |
| Fit on mainshaft (tight)       | -0.0004       | -0.010        |
| Fit on mainshaft (loose)       | +0.0012       | +0.030        |

**Table 5-11. Shifter Fork Specifications**

**Table 5-11. Shifter Fork Specifications**

| <b>SHIFTER FORKS</b>                                      | <b>IN</b>   | <b>MM</b>    |
|---|-------------|--------------|
| Shifter fork to cam groove end play                       | 0.004-0.012 | 0.102-0.305  |
| Shifter fork to dog ring end play                         | 0.004-0.016 | 0.102-0.4060 |
| First and second gear shift fork pad thickness wear limit | 0.258       | 6.55         |

| <b>SHIFTER FORKS</b>                                      | <b>IN</b> | <b>MM</b> |
|---|-----------|-----------|
| Third and fourth gear shift fork pad thickness wear limit | 0.198     | 5.03      |
| Fifth and sixth gear shift fork pad thickness wear limit  | 0.258     | 6.55      |





## **POWER FLOW**

See Figure 5-1. The 6-speed transmission consists of two parallel shafts supporting six gears each. The longer, or mainshaft (7), also supports the clutch and serves as the input shaft. The shorter shaft is called the countershaft (8).

Each gear on the mainshaft is in constant mesh with a corresponding gear on the countershaft. Each of these six pairs of gears makes up a different speed in the transmission.

The transmission gears are divided into two types, gears that rotate with the shaft, and gears that spin freely on the shaft. A gear that rotates with the shaft always meshes with a freewheeling gear. Also, three dog rings are able to slide sideways on the shaft. These dog rings are used to change transmission speeds. The dogs on the sides of dog rings engage dogs on adjacent freewheeling gears, transmitting power through the transmission.

Gear shifting is accomplished by three forks which fit into grooves machined into the dog rings that slide on the guide hubs. The position of the shifter forks is controlled by a drum-shaped shifter cam located in the transmission bearing housing.

### **Neutral**

Power is introduced to the transmission through the clutch. In neutral, with the clutch engaged, the mainshaft first, second, third and fourth gears are rotating. No power is transferred to the countershaft since countershaft first, second, third and fourth gears are freewheeling gears.

### **First Gear**

When the transmission is shifted into first gear, the dog ring between countershaft first and second, which rotates with the countershaft, engages countershaft first, which has been spinning freely on the countershaft driven by mainshaft first.

Now countershaft first is no longer freewheeling, but locked to the countershaft causing the countershaft and countershaft sixth to turn. Countershaft sixth transmits the power to the main drive gear and the sprocket as shown (1).

### **Second Gear**

Second gear is engaged when the dog ring between countershaft first and second is shifted out of countershaft first and engages countershaft second. This locks countershaft second to the countershaft to complete the power flow as shown (2).

### **Third Gear**

Two shifter forks are used to make the shift from second to third. One fork moves the dog ring between countershaft first and second to its neutral position. At the same time another fork engages the dog ring between countershaft third and fourth with countershaft third. This locks countershaft third to the countershaft to complete the power flow as shown (3).

### **Fourth Gear**

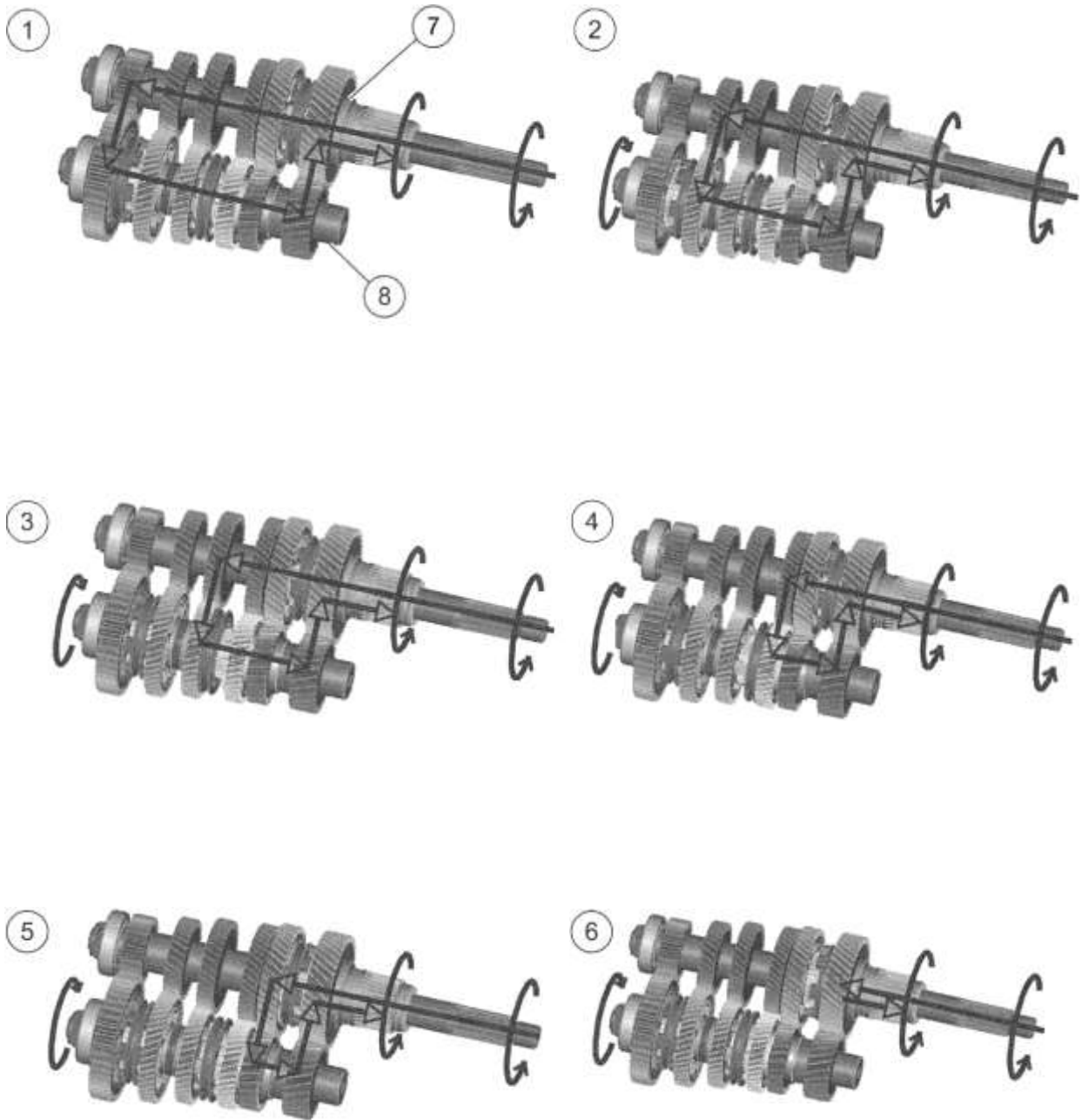
Fourth gear is engaged when the dog ring between countershaft third and fourth is shifted out of countershaft third and engages countershaft fourth. This locks countershaft fourth to the countershaft to complete the power flow as shown (4).

### **Fifth Gear**

Two shifter forks are used to make the shift from fourth to fifth. One fork moves the dog ring between countershaft third and fourth to its neutral position. At the same time another fork engages the dog ring between mainshaft fifth and sixth with mainshaft fifth. This locks mainshaft fifth to the mainshaft to complete the power flow as shown (5).

### **Sixth Gear**

The shift from fifth to sixth gear occurs when the dog ring between mainshaft fifth and sixth is shifted out of mainshaft fifth. It is shifted directly into the main drive gear (sixth gear). The main drive gear is locked to the mainshaft. This results in a direct one-to-one drive ratio from the clutch to the sprocket as shown (6).



- 1. First gear
- 2. Second gear
- 3. Third gear
- 4. Fourth gear

- 5. Fifth gear
- 6. Sixth gear
- 7. Mainshaft
- 8. Countershaft

Figure 5-1. Transmission Power Flow

## PREPARE

### A WARNING

To prevent accidental vehicle start-up, which could cause death or serious injury, disconnect negative (■) battery cable before proceeding. (00048a)

1. Disconnect negative battery cable. See POWER DISCONNECT (Page 8-8).
2. Remove saddlebags. See SADDLEBAGS (Page 3-161).
3. Remove rear wheel. See REAR WHEEL (Page 3-14).
4. Remove rear fork. See REAR FORK (Page 3-75).
5. Remove primary chain, clutch, engine compensating sprocket and chain adjuster. See DRIVE COMPONENTS (Page 5-16).
6. Remove primary chaincase housing. See PRIMARY CHAINCASE HOUSING (Page 5-25).

## REMOVE

1. Remove belt from transmission sprocket.

## INSTALL

### A WARNING

Never bend belt forward into a loop smaller than the drive sprocket diameter. Never bend belt into a reverse loop. Over bending can damage belt resulting in premature failure, which could cause loss of control and death or serious injury. (00339a)

1. Install belt over transmission sprocket.

## COMPLETE

1. Install primary chaincase housing. See PRIMARY CHAINCASE HOUSING (Page 5-25).
2. Install primary chain, clutch, engine compensating sprocket and chain adjuster. See DRIVE COMPONENTS (Page 5-16).
3. Install rear fork. See REAR FORK (Page 3-75).
4. Install rear wheel. See REAR WHEEL (Page 3-14).
5. Install saddlebags. See SADDLEBAGS (Page 3-161).
6. Connect negative battery cable. See POWER DISCONNECT (Page 8-8).

## SHIFTER ROD

| FASTENER           | TORQUE VALUE  |            |
|--------------------|---------------|------------|
| Shifter rod jamnut | 80-120 in-lbs | 9-13.6 N-m |
| Shifter rod nut    | 8-12 ft-lbs   | 11-16 N-m  |

### Remove

1. See Figure 5-2. Remove shifter rod.
  - a. Remove ball stud (14) from rear shifter rod lever.
  - b. Remove nut (11) and washer (12).
  - c. Remove shifter rod (2).

### Install

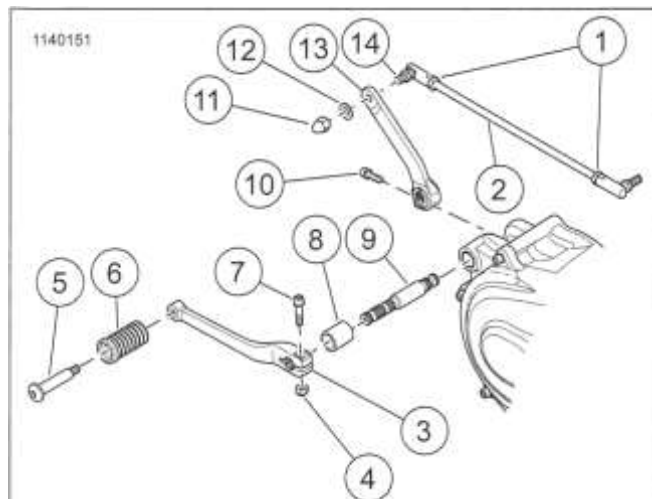
1. See Figure 5-2. Install shifter rod.
  - a. Install rear ball stud (14) to rear shifter rod lever.
  - b. Install front of shifter rod (2) through shifter rod lever (13).
  - c. Install washer (12) on ball stud.
  - d. Install nut (11). Tighten.  
Torque: 8-12 ft-lbs (11-16 N-m) *Shifter rod nut*

### Adjustment

1. **NOTE**
  - *The shifter rod should not require adjustment under normal circumstances. However, if full gear engagement or full lever travel is not achieved, adjust shifter rod.*
  - *Do not allow shift levers to contact footboard when shifting. This prevents proper gear engagement. Contact may also damage transmission.*

See Figure 5-2. Adjust shifter rod.

- a. Loosen jamnuts (1).
- b. Remove nut (11) and washer (12).
- c. Remove front of shifter rod (2).
- d. Adjust rod as necessary.
- e. Install front of shifter rod through shifter rod lever (13).
- f. Install washer on ball stud (14).
- g. Install nut (11). Tighten.  
Torque: 8-12 ft-lbs (11-16 N-m) *Shifter rod nut*
- h. Tighten jamnuts (1).  
Torque: 80-120 **in-lbs** (9-13.6 N-m) *Shifter rod jamnut*



1. Jamnut (2)
2. Shifter rod
3. Shift lever (2)
4. Nut (2)
5. Peg screw (2)
6. Peg (2)
7. Shift lever pinch screw (2)
8. Spacer
9. Shift lever shaft
10. Shift rod lever pinch screw
11. Nut
12. Washer
13. Shifter rod lever
14. Ball stud (2)

Figure 5-2. Shifter Linkage

## FOOT SHIFT LEVER

| FASTENER                | TORQUE VALUE    |               |
|-------------------------|-----------------|---------------|
| Shift lever pinch screw | 9.0-12.0 ft-lbs | 12.2-16.3 N-m |
| Shifter peg screw       | 96-144 in-lbs   | 10.9-16.3 N-m |

### Remove

1. See Figure 5-2 Remove shifter lever.
  - a. Mark position of lever (3) in relation to shaft (9).
  - b. Remove screw (7) and nut (4).
  - c. Remove lever from shaft.
  - d. Remove spacer (8).
2. Remove peg.
  - a. Remove screw (5).
  - b. Remove peg (6).

### Install

1. See Figure 5-2. Install pegs.
  - a. Install screw (5) through peg (6)

- b. Install screw to lever (3). Tighten.  
Torque: 96-144 in-lbs (10.9-16.3 N-m) *Shifter peg screw*

2. Install shifter lever.

- a. Install spacer (8) on shaft (9).
- b. Align and install lever (3) to mark made during removal.

**NOTE**

*Shift lever peg height is a customer preference. During installation, check operation of shift lever. To achieve proper gear engagement and to avoid damage to transmission, peg must not contact footboard when shifting.*

- c. Install screw (7) and nut (4). Tighten.  
Torque: 9.0-12.0 ft-lbs (12.2-16.3 N-m) *Shift lever pinch screw*

3. Verify shift lever operation.

**SHIFTER ROD LEVER. FRONT** \_\_\_\_\_

| FASTENER                                   | TORQUE VALUE   |               |
|--|----------------|---------------|
| Shifter rod lever pinch screw, front lever | 132-156 in-lbs | 14.9-17.6 N-m |
| Shifter rod nut                            | 8-12 ft-lbs    | 11-16 N-m     |

**Remove**

- 1. See Figure 5-2. Remove shifter rod.
  - a. Remove nut (11) and washer (12).

- b. Remove shifter rod (2).

2. Remove shifter rod lever.

- a. Mark position of shifter rod lever (13) in relation to shaft (9).
- b. Remove screw (10).
- c. Slide shaft (9) out enough to remove shift rod lever.

**Install**

1. See Figure 5-2. Install shifter rod lever.

- a. Align and install lever (13) to marks made on shifter shaft (9) during removal.
- b. Slide shifter shaft through lever.
- c. Install screw (10). Tighten.

Torque: 132-156 in-lbs (14.9-17.6 N-m) *Shifter rod lever pinch screw, front lever*

2. Install shifter rod.

- a. Install shifter rod (1) through shifter rod lever (13).
- b. Install washer (12) on shifter rod stud.
- c. Install nut (11). Tighten.  
Torque: 8-12 ft-lbs (11-16 N-m) *Shifter rod nut*

3. Verify shift lever operation.

## PREPARE

1. Remove main fuse. See POWER DISCONNECT (Page 8-8).
2. Remove exhaust system as needed. See EXHAUST SYSTEM (Page 6-34).
3. Drain transmission. See REPLACE TRANSMISSION LUBRICANT (Page 2-13).

## REMOVE

### NOTE

Actuating the clutch hand lever after removing the six screws will help break the cover free.

1. See Figure 5-3. Remove screws (1-6).
2. See Figure 5-4. Remove clutch release cover (5).
3. Discard gasket (7).

## INSTALL

| FASTENER                    | TORQUE VALUE   |               |
|-----------------------------|----------------|---------------|
| Clutch cable fitting        | 90-120 in-lbs  | 10.2-13.6 N-m |
| Clutch release cover screws | 132-156 in-lbs | 14.9-17.6 N-m |

1. Verify two dowel pins are in place on transmission bearing housing flange.
2. Install new gasket.
3. Install clutch release cover.
4. See Figure 5-3. Install screws. Tighten in sequence shown. Torque: 132-156 in-lbs (14.9-17.6 N-m) *Clutch release cover screws*
5. Tighten clutch cable fitting, if removed. Torque: 90-120 in-lbs (10.2-13.6 N-m) *Clutch cable fitting*

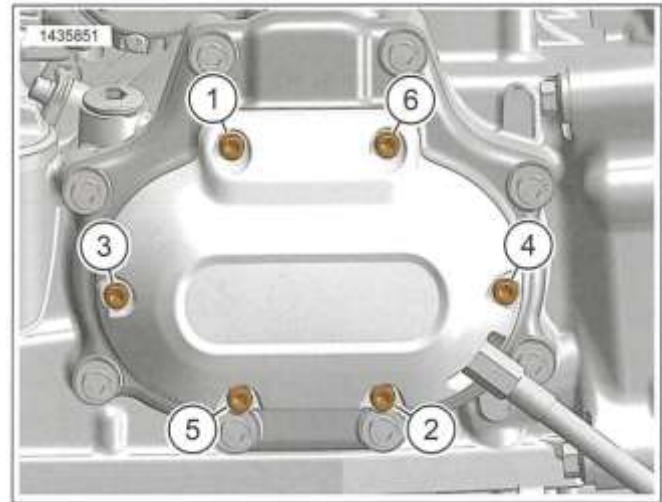


Figure 5-3. Clutch Release Cover Torque Sequence (Short Screws at Locations 1 and 6)

## DISASSEMBLE

### NOTE

Do not separate clutch cable halves.

1. Add free play to clutch cable. See CHECK AND ADJUST CLUTCH (Page 2-27).

### A WARNING

Wear safety glasses or goggles when removing or installing retaining rings. Retaining rings can slip from the pliers and could be propelled with enough force to cause serious eye injury. (00312a)

2. See Figure 5-5. Disconnect clutch cable.
  - a. Remove retaining ring (4).
  - b. Lift inner ramp (5) and ramp coupling (3) out of clutch release cover.
  - c. Disconnect clutch cable end (2) from ramp coupling (3).
3. Remove coupling (3) from inner ramp.
4. See Figure 5-6. Remove balls (4) and outer ramp (2).
5. See Figure 5-5. Remove cable fitting (1) from clutch release cover.

## CLEAN AND INSPECT

1. See Figure 5-4. Wash the ball and ramp mechanism components in cleaning solvent.
2. Inspect the three balls (2) and ball socket surfaces on ramps (1,3) for wear, pitting, surface breakdown and other damage. Replace as necessary.
3. Check fit of the ramp coupling (4) on inner ramp (1). Replace both parts if there is excessive wear.

4. Inspect the retaining ring (6) for damage or distortion.
5. Check clutch cable end for frayed or worn ends. Replace cable if damaged or worn. Check cable fitting O-ring for damage.
6. Check the bore in the clutch release cover (5) where the ramps (1, 3) are retained. There should be no wear that would cause the ramps to tilt, causing improper clutch adjustment.

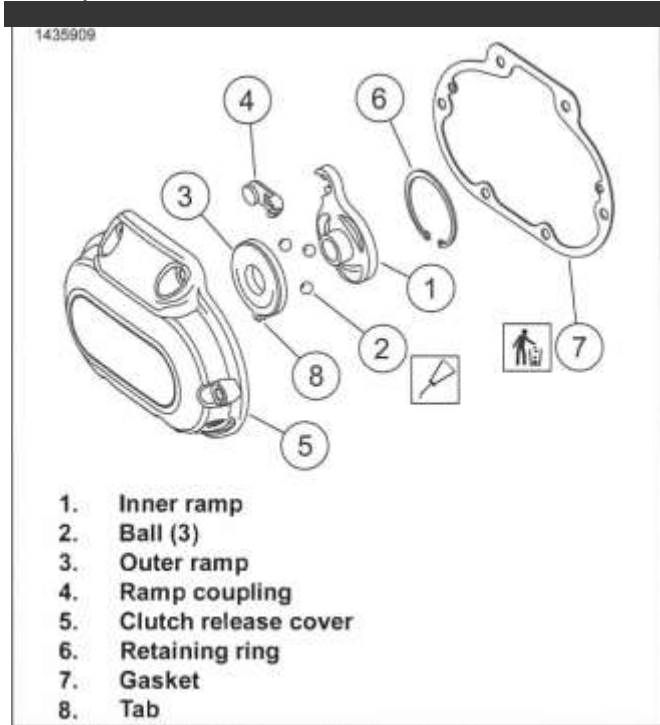


Figure 5-4. Release Mechanism Assembly

### ASSEMBLE

#### NOTE

Replace cable fitting O-ring if damaged.

1. See Figure 5-5. Apply a drop of LOCTITE 243 MEDIUM STRENGTH THREADLOCKER AND SEALANT (blue) to the clutch cable fitting (1).
2. Install clutch cable fitting in clutch release cover. Leave fasteners loose.
3. See Figure 5-6. Place outer ramp (2) with ball socket side up in clutch release cover. Confirm outer ramp tab (3) is in clutch release cover slot.
4. Apply a multi-purpose grease to the balls (4) and outer ramp sockets. Place a ball in each of the outer ramp sockets.
5. See Figure 5-5. Connect clutch cable.
  - a. Connect clutch cable end (2) to ramp coupling (3).
  - b. Install coupling on inner ramp (5).
  - c. Place inner ramp and coupling in position in clutch release cover.

### A WARNING

**Wear safety glasses or goggles when removing or installing retaining rings. Retaining rings can slip from the pliers and could be propelled with enough force to cause serious eye injury. (00312a)**

6. Install retaining ring.
  - a. Center retaining ring opening (6) above break in ribbing at bottom of clutch release cover.
- b. Install retaining ring (4).

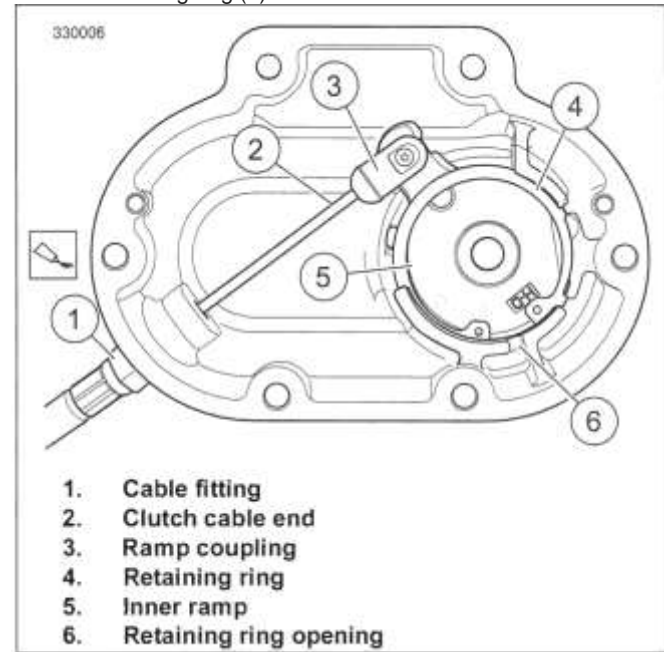


Figure 5-5. Clutch Cable Connection

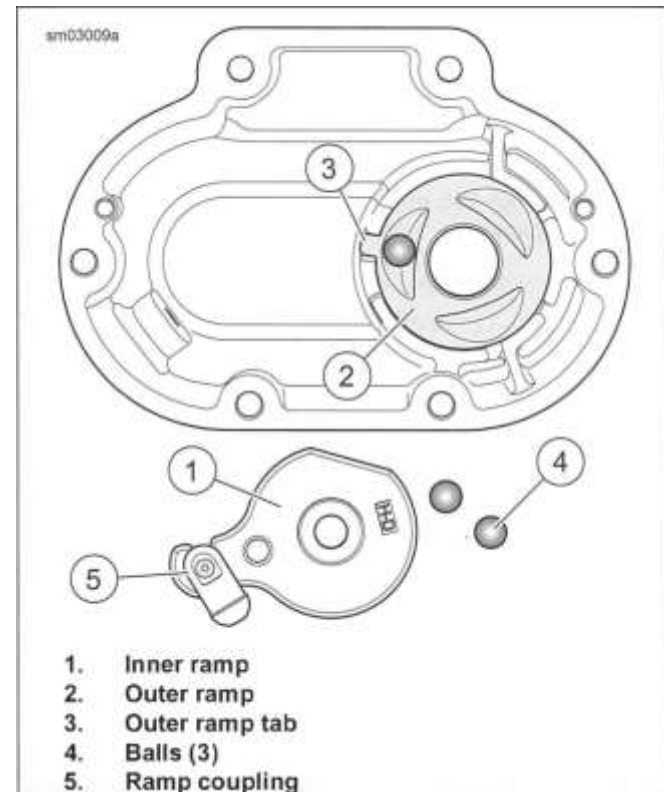


Figure 5-6. Coupling and Ramp Assembly

## **COMPLETE**

1. Fill transmission. See REPLACE TRANSMISSION LUBRICANT (Page 2-13).
2. Adjust clutch. See CHECK AND ADJUST CLUTCH (Page 2-27).
3. Install exhaust system if removed. See EXHAUST SYSTEM (Page 6-34).
4. Install main fuse. See POWER DISCONNECT (Page 8-8)



## PREPARE

1. Remove clutch inspection cover. See REPLACE PRIMARY CHAINCASE LUBRICANT (Page 2-11).
2. If necessary:
  - a. Drain transmission lubricant. See REPLACE TRANSMISSION LUBRICANT (Page 2-13).
  - b. Remove mufflers. See MUFFLERS (Page 6-33).
  - c. Remove exhaust system if needed. See EXHAUST SYSTEM (Page 6-34).
  - d. Remove clutch release cover. See CLUTCH RELEASE COVER (Page 5-9).

## REMOVE

### Right Side

1. See Figure 5-8. Remove oil slinger (4).
2. Disassemble oil slinger.
  - a. Remove retaining ring (1).
  - b. Remove throw out bearing (3) with thrust washers (2).
3. If necessary, remove push rod (5).

### Left Side

1. See Figure 5-7. Loosen jamnut (4).
2. Loosen adjuster screw (5).
3. Remove retaining ring (3).
4. Remove release plate (2).
5. If necessary, remove push rod (1).

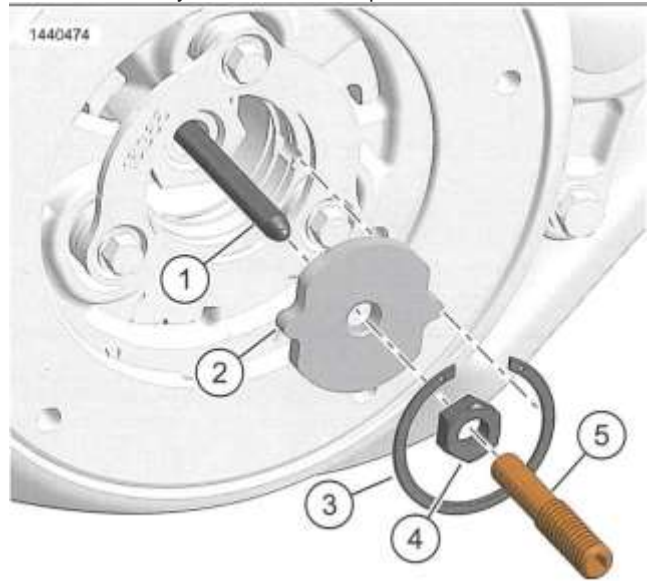
## INSTALL

### Left Side

1. See Figure 5-7. Verify push rod (1) is installed.
2. Install release plate (2).
3. Install retaining ring (3).
4. Install adjuster screw (5).
5. Install jam nut (4).

### Right Side

1. See Figure 5-8. Verify push rod (5) is installed.
2. Assemble bearing on oil slinger.
  - a. Install one thrust washer (2) on oil slinger (4).
  - b. Install throw out bearing (3) on oil slinger.
  - c. Install second thrust washer on oil slinger.
  - d. Install retaining ring (1) in groove.
3. Install assembly in transmission input shaft.



1. Push rod
2. Release plate
3. Retaining ring
4. Jamnut
5. Adjuster screw

Figure 5-7. Left Side Clutch Push Rod

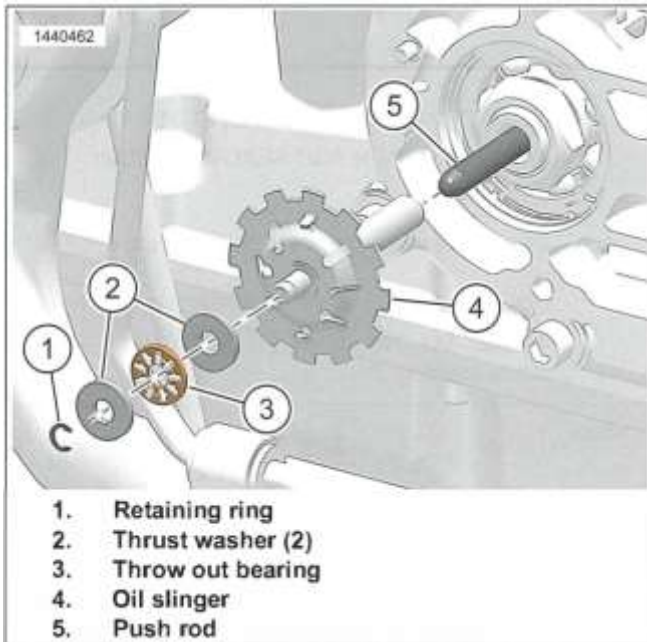


Figure 5-8. Right Side Clutch Push Rod

## COMPLETE

1. If necessary:
  - a. Install clutch release cover. See CLUTCH RELEASE COVER (Page 5-9).
  - b. Fill transmission. See REPLACE TRANSMISSION LUBRICANT (Page 2-13).
  - c. Install exhaust system if removed. See EXHAUST SYSTEM (Page 6-34).
  - d. Install mufflers. See MUFFLERS (Page 6-33).
2. Adjust clutch. See CHECK AND ADJUST CLUTCH (Page 2-27).
3. Install clutch inspection cover. See REPLACE PRIMARY CHAINCASE LUBRICANT (Page 2-11).

## PREPARE

### A WARNING

To prevent accidental vehicle start-up, which could cause death or serious injury, disconnect negative (-) battery cable before proceeding. (00048a)

1. Disconnect negative battery cable. See POWER DISCONNECT (Page 8-8)
2. Remove passenger left footboard and bracket if necessary. See FOOTBOARDS AND FOOTRESTS (Page 3-155). See RIDER FOOTRESTS (Page 3-142)
3. Remove rider left footboard and bracket. See RIDER FOOTRESTS (Page 3-142).
4. Remove screw securing jiffy stand interlock sensor, if equipped. See JIFFY STAND SENSOR (JSS) (Page 8-104).
5. Remove heel shift lever. See SHIFTER LINKAGE (Page 5-7).
6. Drain primary chaincase oil. See REPLACE PRIMARY CHAINCASE LUBRICANT (Page 2-11)

## REMOVE

1. See Figure 5-9. Remove primary chaincase cover.
  - a. Remove cover screws (4, 5).
  - b. Remove cover (3).
  - c. Remove and discard gasket (1).

## INSTALL

| FASTENER             | TORQUE VALUE  |               |
|----------------------|---------------|---------------|
| Primary cover screws | 144-156in-lbs | 16.3-17.6 N-m |

| PART NUMBER | CONSUMABLE  |
|-------------|---|
| 99642-97    | LOCTITE 243 MEDIUM STRENGTH THREADLOCKER AND SEALANT (BLUE) |

1. See Figure 5-9. Verify all debris is washed from inside ribs of cover.
2. Verify hollow dowels (2) are installed properly.
3. Install **new** cover gasket (1).
4. Install cover.
  - a. Apply a drop of threadlocker to threads of screws (4, 5).

LOCTITE 243 MEDIUM STRENGTH THREADLOCKER AND SEALANT (BLUE) (99642-97)

- b. Install cover with screws in positions shown.
- c. See Figure 5-10. Tighten in sequence shown.

Torque: 144-156 **in-lbs** (16.3-17.6 N-m) *Primary cover screws*

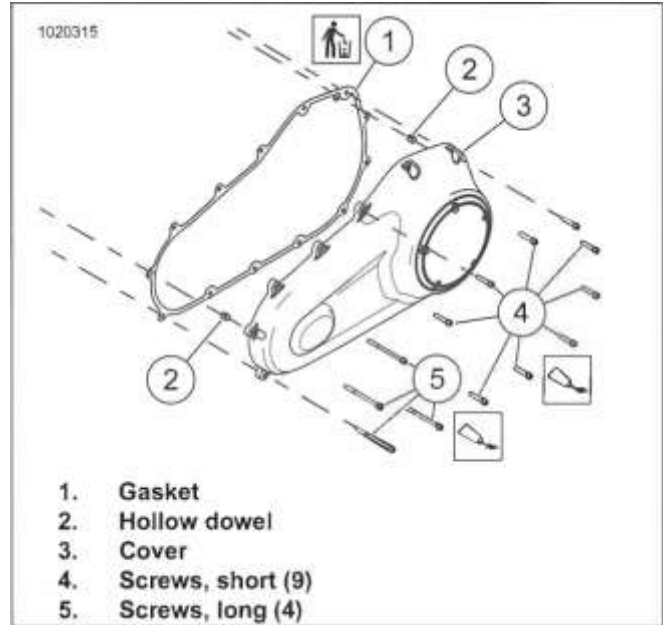


Figure 5-9. Primary Chaincase Cover

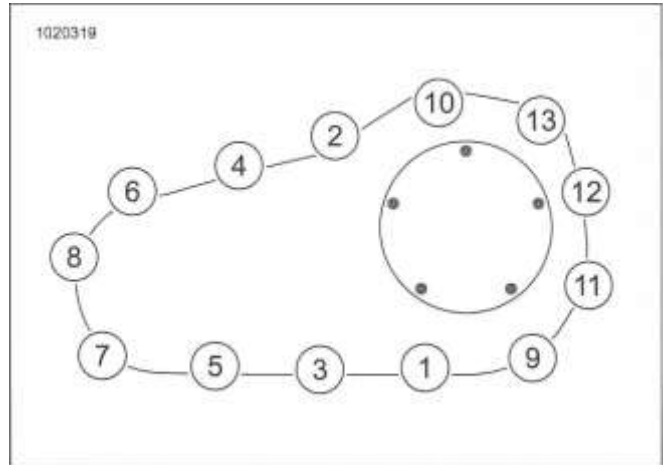


Figure 5-10. Primary Chaincase Cover Torque Sequence

## COMPLETE

1. Install heel shift lever. See SHIFTER LINKAGE (Page 5-7).
2. Install rider footboard and bracket, if removed. See RIDER FOOTRESTS (Page 3-142).
3. Install screw securing jiffy stand interlock sensor, if equipped. See JIFFY STAND SENSOR (JSS) (Page 8-104).

4. Fill primary chaincase with oil. See REPLACE PRIMARY CHAINCASE LUBRICANT (Page 2-11).
5. Install negative battery cable. See POWER DISCONNECT (Page 8-8).

## PREPARE

### A WARNING

**To prevent accidental vehicle start-up, which could cause death or serious injury, disconnect negative (-) battery cable before proceeding. (00048a)**

1. Disconnect negative battery cable. See POWER DISCONNECT (Page 8-8).
2. Remove rider left footboard and bracket, if necessary. See RIDER FOOTRESTS (Page 3-142).
3. Remove heel shifter lever. See SHIFTER LINKAGE (Page 5-7).
4. Drain primary chaincase oil. See REPLACE PRIMARY CHAINCASE LUBRICANT (Page 2-11).
5. Remove clutch release plate and pushrod. See CLUTCH RELEASE PUSH ROD COMPONENTS (Page 5-12).
6. Remove primary chaincase cover. See PRIMARY CHAINCASE COVER (Page 5-14).

## REMOVE

| PART NUMBER | TOOL NAME                  |
|-------------|----------------------------|
| HD-48219    | PRIMARY DRIVE LOCKING TOOL |

1. See Figure 5-11. Remove chain tensioner.
  - a. Install cable strap (2) as shown. Exposed portion of cable strap below cover indicates need for removal before cover installation.
  - b. See Figure 5-12. Remove chain tensioner fasteners (2).
  - c. Remove chain tensioner (1).
2. Mark one link on primary chain for reference during installation.

### NOTE

Release plate and clutch hub do not need to be removed if only removing compensating sprocket.

Remove release plate. See CLUTCH RELEASE PUSH ROD COMPONENTS (Page 5-12).

### NOTE

Mainshaft nut has left-hand threads.

See Figure 5-13. Remove mainshaft nut.

- a. Place special tool between sprockets as shown.  
Special Tool: PRIMARY DRIVE LOCKING TOOL (HD-48219)

- b. Rotate clutch hub mainshaft nut (4) clockwise to remove.
5. See Figure 5-14. Remove compensating sprocket bolt.
  - a. Place primary drive locking tool between sprockets as shown.
  - b. Rotate compensating sprocket bolt (1) counterclockwise to loosen.
  - c. See Figure 5-15. Remove bolt (9), retainer (8) and thrust washer (7).
6. Inspect thrust washers (7) for damage.
7. Remove clutch assembly, primary chain and compensating sprocket assembly as a single unit.
8. Clean sprocket retainer (8). Verify that oil holes are clear.

## INSTALL

| PART NUMBER | TOOL NAME                  |
|-------------|----------------------------|
| HD-48219    | PRIMARY DRIVE LOCKING TOOL |

| FASTENER                                 | TORQUE VALUE |                |
|--|--------------|----------------|
| Clutch hub mainshaft nut                 | 70-80 ft-lbs | 94.9-108.5 N-m |
| Compensating sprocket bolt, 1st torque   | 100 ft-lbs   | 135.6 N-m      |
| Compensating sprocket bolt, final torque | 175 ft-lbs   | 237.3 N-m      |
| Primary chain tensioner fasteners        | 21-24 ft-lbs | 28.5-32.6 N-m  |

| PART NUMBER | CONSUMABLE   |
|-------------|--|
| 94759-99    | LOCTITE 262 HIGH STRENGTH THREADLOCKER AND SEALANT (RED) |

### NOTE

O-ring inside shaft extension is for manufacturing assembly only and has no replacement part number.

1. See Figure 5-15 and Figure 5-16. Install spring washers.
  - a. Apply a thin layer of primary chaincase oil to inner diameter of compensating sprocket (6) and splines of shaft extension (1).
  - b. Install shaft extension.
  - c. Install large spring washers (2) and medium spring washers (3). Outer diameter of spring washers must contact each other.
  - d. Install small spring washer (4) so outer diameter contacts sliding cam (5).

Install primary chain, compensating sprocket and clutch as an assembly.

3. Lightly lubricate thrust washer (7). Install components (7, 8) and **new** bolt (9). Hand tighten.

**NOTE**

*Clutch hub mainshaft nut has left-hand threads.*

4. See Figure 5-17. Install mainshaft nut.
  - a. Clean and prime threads of clutch hub mainshaft nut (2).
  - b. Apply threadlocker to nut threads.  
LOCTITE 262 HIGH STRENGTH THREADLOCKER AND SEALANT (RED) (94759-99)
  - c. Install nut onto mainshaft. Hand-tighten.
5. See Figure 5-18. Tighten compensating sprocket bolt.
  - a. Place special tool between sprockets as shown.  
Special Tool: PRIMARY DRIVE LOCKING TOOL (HD-48219)
  - b. Tighten compensating sprocket bolt (1).  
Torque: 100 ft-lbs (135.6 N-m) *Compensating sprocket bolt, 1st torque*
  - c. Loosen one-half turn.
  - d. Final torque.  
Torque: 175 ft-lbs (237.3 N-m) *Compensating sprocket bolt, final torque*
6. See Figure 5-17. Tighten clutch hub mainshaft nut.
  - a. Place special tool between sprockets as shown.  
Special Tool: PRIMARY DRIVE LOCKING TOOL (HD-48219)
  - b. Tighten clutch hub mainshaft nut (2).  
Torque: 70-80 ft-lbs (94.9-108.5 N-m) *Clutch hub mainshaft nut*
7. Install release plate. See CLUTCH RELEASE PUSH ROD COMPONENTS (Page 5-12).
8. If primary chain tensioner becomes disassembled, assemble in order shown.

**NOTE**

- *Primary chain tensioner is non-repairable. If tensioner is worn or damaged, replace assembly*
- *Chain tensioner is not interchangeable with previous model year parts. Shoe color is black.*
  - a. See Figure 5-19. Locate end of spring rod (2) on roll pin (3).
  - b. See Figure 5-20. Slide wedge (2) of primary chain tensioner in direction of arrow until ' all travel is removed.
  - c. See Figure 5-11. Push shoe (1) down until it contacts wedge. Keep tension on shoe so wedge stays in place.
  - d. Attach cable strap (2) as shown to hold wedge in place. Verify that end of cable strap hangs below

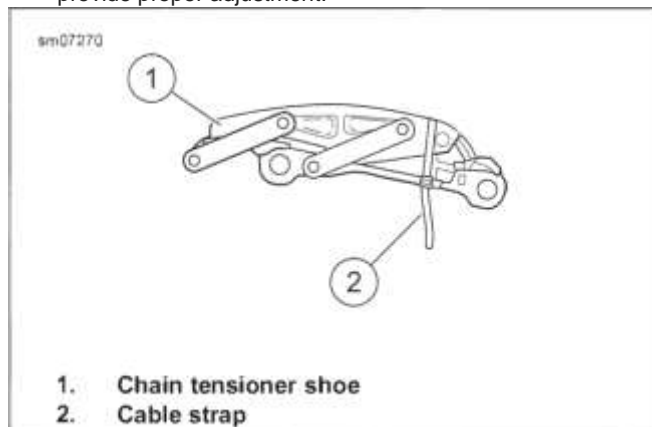
primary chain tensioner. Cable strap serves as a reminder to remove before installing primary cover.

9. See Figure 5-12. Install primary chain tensioner.
  - a. Install primary chain tensioner (1) with fasteners (2). Tighten.  
Torque: 21-24 ft-lbs (28.5-32.6 N-m) *Primary chain tensioner fasteners*
  - b. Remove cable strap.
10. Set preliminary chain tension.
  - a. Check tension at the top span while pulling down on chain midway between sprockets. Correct tension is  
**0. 500-0.625 in (12.7-15.88 mm)**
  - b. If chain is loose, move chain adjuster one notch. Check tension.
  - c. Repeat steps until tension is within specification.

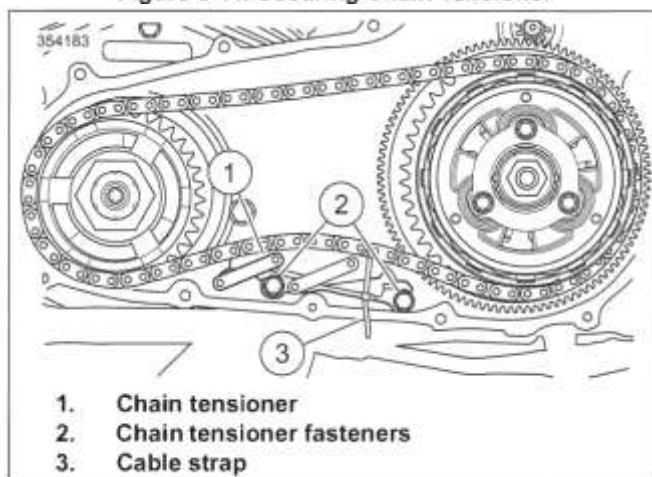
**NOTE**

*Primary chain tensioner will not complete chain adjustment until vehicle is ridden.*

11. Test ride vehicle after tensioner removal/installation to provide proper adjustment.



**Figure 5-11. Securing Chain Tensioner**



**Figure 5-12. Chain Tensioner**

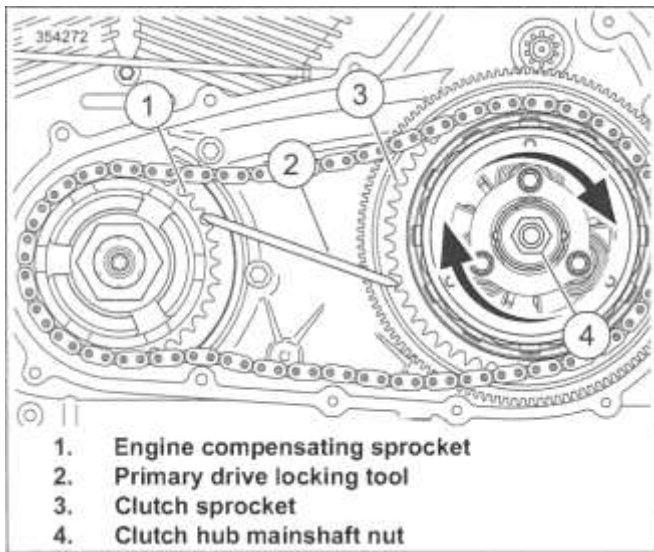


Figure 5-13. Removing Clutch Hub Mainshaft Nut

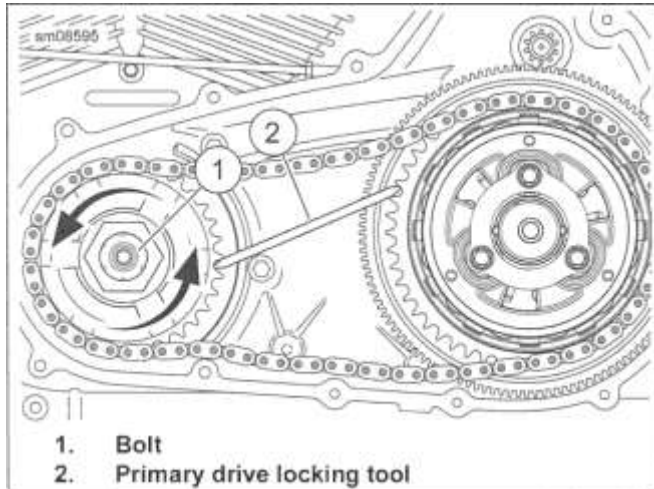


Figure 5-14. Removing Engine Compensating Sprocket Bolt

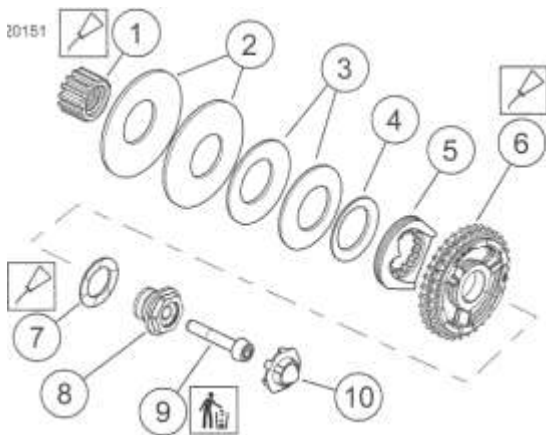


Figure 5-15 , Engine Compensating Sprocket Assembly

sm05990b



1. Large spring washer (2)
2. Medium spring washer (2)

Figure 5-16. Spring Washer Orientation

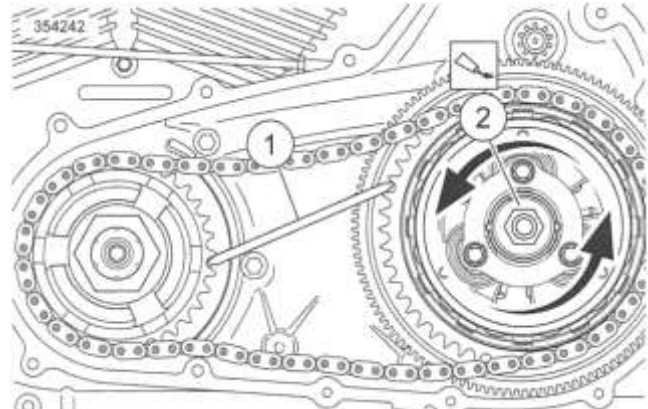


Figure 5-17. Installing Clutch Hub Mainshaft Nut

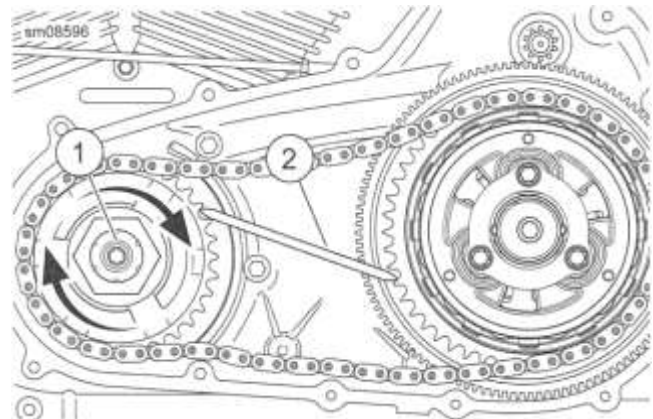


Figure 5-18. Installing Engine Compensating Sprocket Bolt

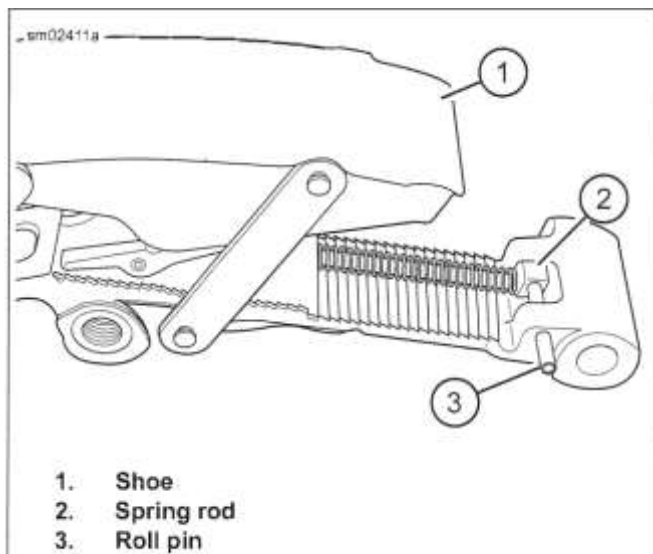


Figure 5-19. Spring Rod Location

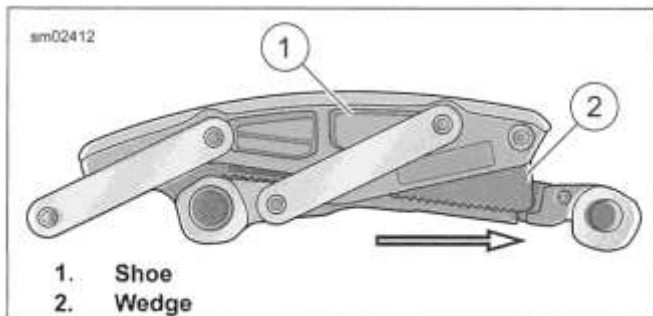


Figure 5-20. Primary Chain Tensioner

## **COMPLETE**

1. Install primary chaincase cover. See PRIMARY CHAINCASE COVER (Page 5-14).
2. Install clutch release plate and pushrod. See CLUTCH RELEASE PUSH ROD COMPONENTS (Page 5-12).
3. Fill primary chaincase with oil. See REPLACE PRIMARY CHAINCASE LUBRICANT (Page 2-11).
4. Install heel shifter lever. See RIDER FOOTRESTS (Page 3-142).
5. Install rider left footboard and bracket, if removed. See RIDER FOOTRESTS (Page 3-142).
6. Install negative battery cable. See POWER DISCONNECT (Page 8-8).



**PREPARE****A WARNING**

To prevent accidental vehicle start-up, which could cause death or serious injury, disconnect negative (-) battery cable before proceeding. (00048a)

1. Disconnect negative battery cable. See POWER DISCONNECT (Page 8-8).
2. Remove rider left footboard and bracket, if necessary. See RIDER FOOTRESTS (Page 3-142).
3. Remove foot shift lever. See SHIFTER LINKAGE (Page 5-7).
4. Drain primary chaincase oil. See REPLACE PRIMARY CHAINCASE LUBRICANT (Page 2-11).
5. Remove primary chaincase cover. See PRIMARY CHAINCASE COVER (Page 5-14).
6. Remove clutch release plate. See CLUTCH RELEASE PUSH ROD COMPONENTS (Page 5-12).

**DISASSEMBLE AND ASSEMBLE: CLUTCH PACK**

This procedure can be performed without removing clutch shell or hub. To replace entire clutch assembly, see DRIVE COMPONENTS (Page 5-16).

**Disassemble**

1. See Figure 5-21. Remove pressure plate.
  - a. Remove bolts (1) alternating each bolt 1-2 turn while removing.
  - b. Remove stopper plate (2).
  - c. Remove springs (4).
  - d. Remove spring seats (5).
  - e. Remove pressure plate (6).
2. Remove friction and steel plates.
  - a. Remove narrow friction plates (7) and narrow steel plate (8).
  - b. Remove wide steel plates (9) and wide friction plates (10).
  - c. Remove narrow friction plate (7).
3. Remove damper spring.
  - a. Remove damper spring (11).

- b. Remove damper spring seat (12).

**Clean and Inspect****A WARNING**

Compressed air can pierce the skin and flying debris from compressed air could cause serious eye injury. Wear safety glasses when working with compressed air. Never use your hand to check for air leaks or to determine air flow rates. (00061a)

**NOTE**

*Friction and steel plates are only sold as a set.*

1. **NOTE**

*Do not wash friction plates or hub bearing with cleaning solvent.*

Wash parts in cleaning solvent. Dry with low-pressure compressed air.

## 2. Check friction plates.

**NOTE**

*Do not use a rag to clean friction plates.*

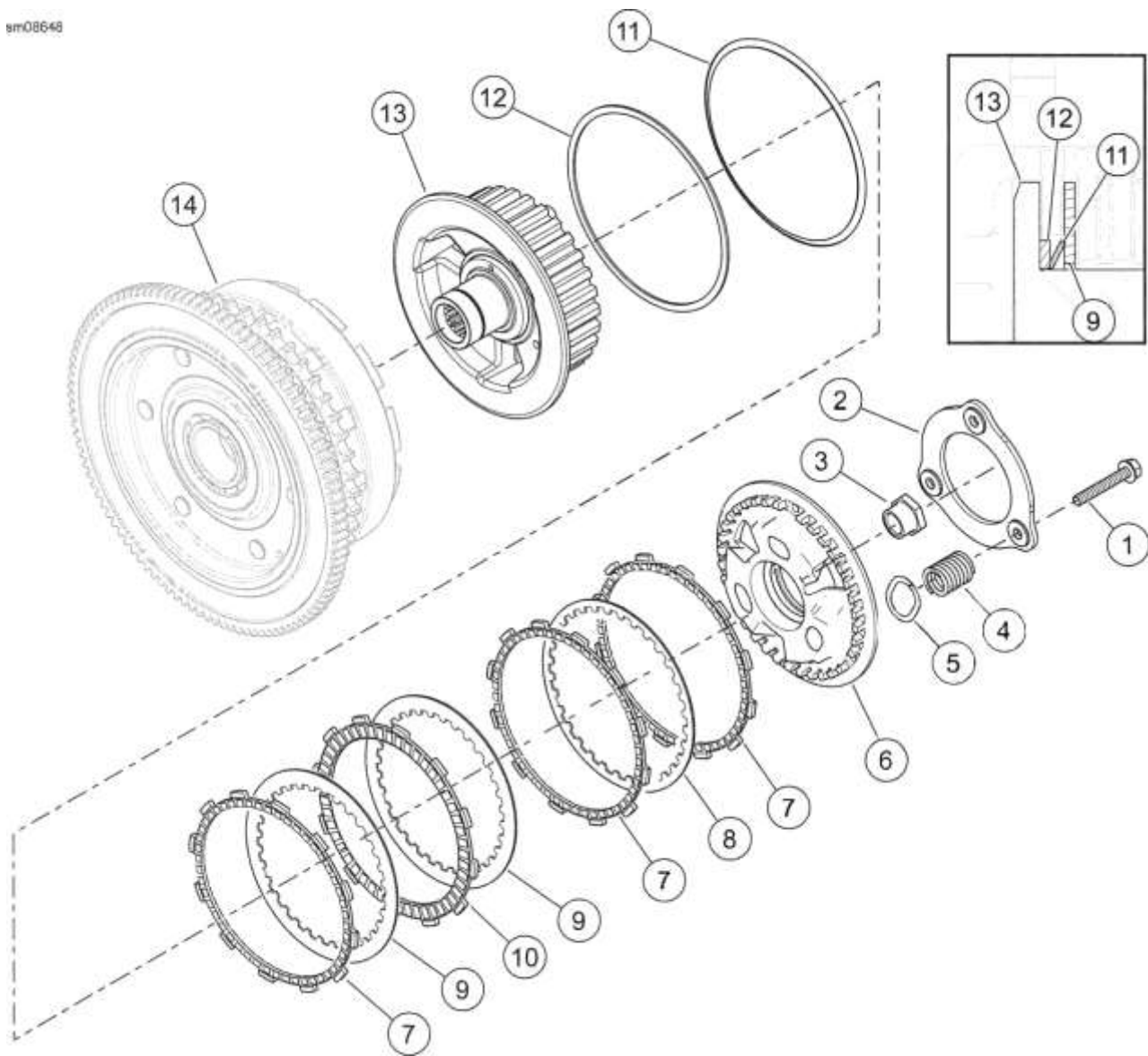
- a. Remove lubricant using compressed air.
  - b. Measure thickness of each plate.
  - c. If thickness of any plate is less than specification, replace entire clutch disc set. Refer to Table 5-12.
  - d. Look for worn or damaged fiber surface material (both sides).
3. Check steel plates for distortion.
    - a. Replace entire clutch disc set if any steel plates are grooved.
    - b. Lay plate on a precision flat surface.
    - c. Using a feeler gauge, check for distortion in several places.
    - d. If any steel plate is warped beyond specification, replace entire clutch disc set.
      0. 006 in (0.15 mm)
  4. Check clutch hub bearing for smooth operation. Replace if necessary. See Disassemble and Assemble: Hub in this section.
  5. Check clutch shell chain sprocket and starter ring gear. Replace if worn or damaged.
  6. Check clutch hub and shell steel plate slots for wear or damage. Replace if necessary.
  7. Check coil springs and stopper plate for wear or damage. Replace if necessary.

**Table 5-12. FRICTION PLATE MINIMUM THICKNESS**

| <b>FRICTION PLATE</b> | <b>MM</b> | <b>IN</b> |
|-----------------------|-----------|-----------|
| Wide Plate            | 2.82      | 0.111     |
| Narrow Plate          | 3.62      | 0.143     |

**Assemble**

1. Submerge and soak all friction plates in primary chaincase lubricant for at least five minutes.
2. See Figure 5-21. Install Damper spring.
  - a. Install damper spring seat (12) into clutch hub (13).
  - b. Install damper spring (11) onto damper spring seat.
3. Install friction and steel plates.
  - a. Install one narrow friction plate (7) into clutch hub.
  - b. Install one wide steel plate (9) onto narrow friction plate and damper spring (11).
4. Install pressure plate.
  - a. Install spring seats (5).
  - b. Align and install pressure plate (6) onto clutch hub (13).
  - c. Install springs (4).
  - d. Install stopper plate (2).
  - e. Install bolts (1). Alternate tightening bolts 1-2 turns to prevent damage to stopper plate.  
Torque: 70-100 **in-lbs** (7.9-11.3 N-m)
- c. Beginning with a wide friction plate (10), alternate remaining wide friction plates with wide steel plates.
- d. Install narrow friction plate (7), narrow steel plate (8) and remaining narrow friction plate.



- |   |  |
|---|--|
| <ul style="list-style-type: none"> <li>1. Bolt (3)</li> <li>2. Stopper plate</li> <li>3. Mainshaft nut</li> <li>4. Coil spring (3)</li> <li>5. Seat (3)</li> <li>6. Pressure plate</li> <li>7. Narrow friction plate (3)</li> </ul> | <ul style="list-style-type: none"> <li>8. Narrow steel plate (1)</li> <li>9. Wide steel plate (8)</li> <li>10. Wide friction plate (7)</li> <li>11. Damper spring</li> <li>12. Damper spring seat</li> <li>13. Clutch hub</li> <li>14. Clutch shell</li> </ul> |
|---|--|

Figure 5-21. Clutch Shell Assembly, 10-plate

### DISASSEMBLE AND ASSEMBLE: HUB

#### Disassemble

#### A WARNING

Wear safety glasses or goggles when removing or installing retaining rings. Retaining rings can slip from the pliers and could be propelled with enough force to cause serious eye injury. (00312a)

#### NOTE

Do not disassemble clutch shell and hub assembly unless bearing, hub or shell require replacement. Replace bearing if disassembled.

1. Press out clutch hub.
  - a. See Figure 5-22. Remove and discard clutch hub retaining ring (2).
  - b. See Figure 5-23. Support clutch shell in press with ring gear side up.

- c. Press hub from bearing in clutch shell.

2. Remove bearing.

- a. See Figure 5-22. Remove and discard bearing retaining ring (1).
- b. See Figure 5-24. Support clutch shell in press with ring gear side is down.
- c. Use a suitable press plug to remove bearing.

3. Clean and inspect components. See Disassemble and Assemble: Clutch Pack (Page 5-20).



Figure 5-22. Clutch Retaining Rings

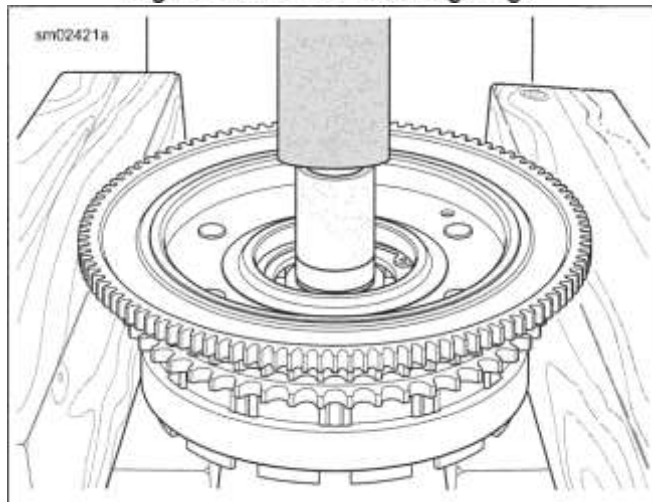


Figure 5-23. Pressing Clutch Hub From Bearing

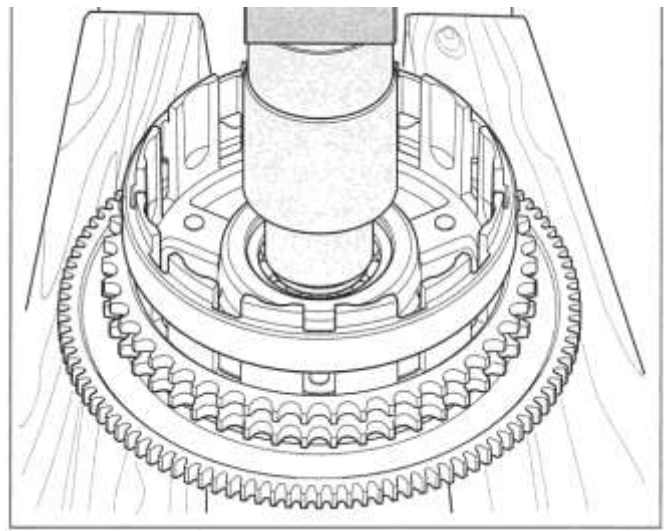


Figure 5-24. Pressing Bearing From Clutch Shell

**Assemble**

1. See Figure 5-23 Install **new** bearing.
  - a. Place clutch shell in press with ring gear side up.
  - b. Support clutch shell bore on sprocket side to avoid damage to ears on clutch basket.
  - c. Using a suitable press plug, press against outer race until bearing contacts shoulder in clutch shell bore.

**A WARNING**

**Wear safety glasses or goggles when removing or installing retaining rings. Retaining rings can slip from the pliers and could be propelled with enough force to cause serious eye injury. (00312a)**

- d. See Figure 5-22. Install **new** bearing retaining ring (1) with flat side toward bearing.
2. Install clutch hub.
  - a. Place clutch shell in press with sprocket side up.
  - b. Center hub in bearing.
  - c. Support bearing inner race with a sleeve on transmission side.
  - d. Press hub into bearing until shoulder contacts bearing inner race.
  - e. Install clutch hub retaining ring (2) in groove of clutch hub.

**COMPLETE**

1. Install clutch release plate. See CLUTCH RELEASE PUSH ROD COMPONENTS (Page 5-12).
2. Install primary chaincase cover. See PRIMARY CHAINCASE COVER (Page 5-14).

3. Fill primary chaincase with oil. See REPLACE PRIMARY CHAINCASE LUBRICANT (Page 2-11).
4. Install foot shift lever. See SHIFTER LINKAGE (Page 5-7).
5. Install rider footboard and bracket, if removed. See RIDER FOOTRESTS (Page 3-142).
6. Install negative battery cable. See POWER DISCONNECT (Page 8-8).

## PREPARE

### A WARNING

To prevent accidental vehicle start-up, which could cause death or serious injury, disconnect negative (-) battery cable before proceeding. (00048a)

1. Disconnect negative battery cable. See POWER DISCONNECT (Page 8-8).
2. Remove rider footboard and bracket, if needed. See RIDER FOOTRESTS (Page 3-142).
3. Drain primary chaincase oil. See REPLACE PRIMARY CHAINCASE LUBRICANT (Page 2-11).
4. Remove primary chaincase cover. See PRIMARY CHAINCASE COVER (Page 5-14).
5. Remove starter. See STARTER (Page 8-11).
6. Remove primary chain, clutch and compensating sprocket. See DRIVE COMPONENTS (Page 5-16).

## REMOVE

1. See Figure 5-25. Remove primary chaincase housing.
  - a. Remove and discard screws (5).
  - b. Remove primary chaincase housing (6).
- c. Discard gasket (7).

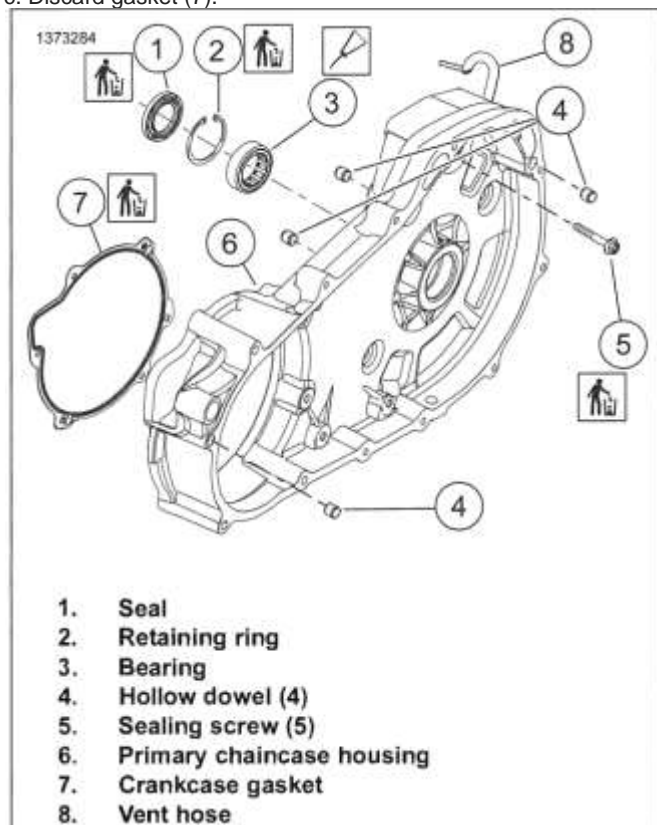


Figure 5-25. Primary Chaincase Housing

1. Inspect primary chaincase for cracks or damaged gasket

## INSPECT

surface.

2. Check mainshaft bearing. Replace if bearing does not rotate freely. See Mainshaft Bearing and Seal (Page 5-26).
3. Replace oil seal. See Mainshaft Bearing and Seal (Page 5-26).
4. Inspect shifter shaft bushing. Replace if necessary. See Shifter Shaft Bushing (Page 5-27).

## INSTALL

| FASTENER                         | TORQUE VALUE |             |
|----------------------------------|--------------|-------------|
| Primary chaincase sealing screws | 26-28 ft-lbs | 35.3-38 N-m |

### NOTE

Cover mainshaft clutch hub splines with tape to prevent splines from damaging primary housing inner oil seal.

1. See Figure 5-27.. Install primary chaincase housing.
  - a. Install gasket on surface (2). Verify dowels in gasket engage dowel holes (3).
  - b. Spread a film of oil on mainshaft oil seal lip and rubber portion of crankcase gasket.
  - c. See Figure 5-25 Install primary chaincase housing (6) .
  - d. See Figure 5-28. Install **new** sealing screws.
  - e. See Figure 5-29. Tighten in sequence shown.

Torque: 26-28 ft-lbs (35.3-38 N-m) *Primary chaincase sealing screws*

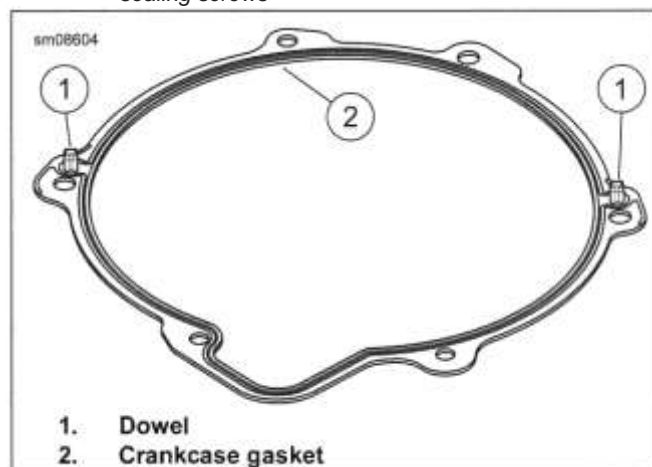
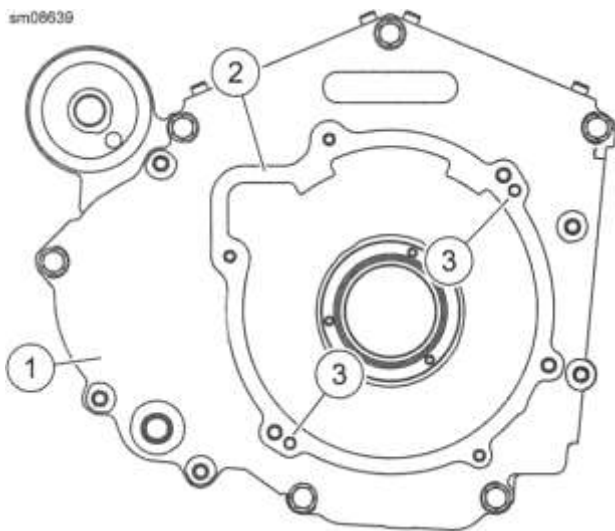


Figure 5-26. Crankcase Gasket

sm08639



1. Crankcase
  2. Gasket surface
  3. Dowel holes
- Figure 5-27. Crankcase

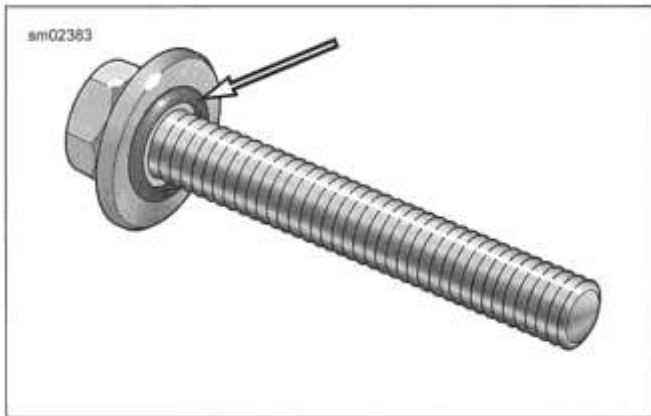


Figure 5-28. Primary Chaincase Sealing Screw

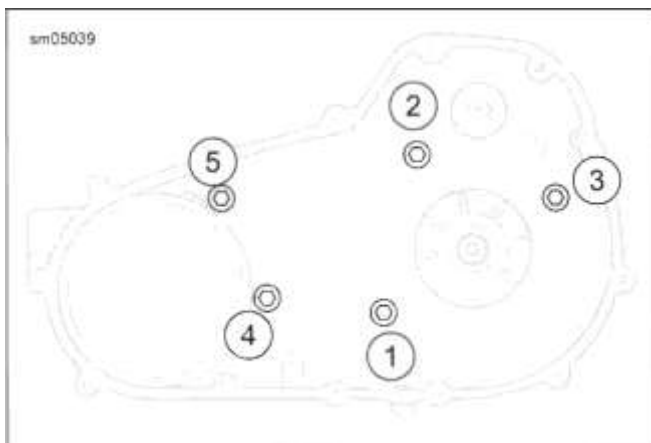


Figure 5-29. Sealing Screw Tightening Sequence

## MAINSHAFT BEARING AND SEAL

1. Remove seal with a seal remover or rolling head pry bar

### A WARNING

Wear safety glasses or goggles when removing or installing retaining rings. Retaining rings can slip from the pliers and could be propelled with enough force to cause serious eye injury. (00312a)

2. See Figure 5-30. Remove and discard retaining ring (1).

#### NOTE

Support the bearing support area on transmission side of primary chaincase while pressing out bearing.

3. Place inner primary chaincase in a press with clutch side up.
4. Press out bearing from clutch side.

### Install

1. Verify that bearing bore is clean and smooth.

#### NOTE

Support the bearing support area on clutch side of primary chaincase while pressing bearing.

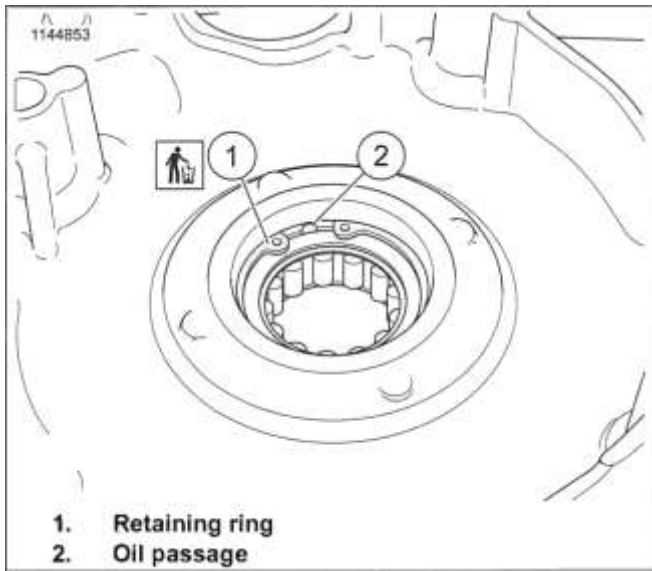
2. Place primary chaincase in a press with transmission side up.
3. Install **new** bearing with letter side up.
  - a. Apply a thin film of oil to outer diameter of bearing.
  - b. Press outer race until it makes solid contact with bearing support area.
4. See Figure 5-30. Install **new** retaining ring.

#### NOTE

Retaining ring (1) must not block oil passage (2).

- a. Install retaining ring on groove on chaincase.
- b. Verify that ring is fully seated in groove.
5. Install mainshaft oil seal.
  - a. Lubricate OD of **new** seal with SCREAMIN' EAGLE ASSEMBLY LUBE.
  - b. Place over bore with lip garter spring side (stamped "OIL SIDE") facing toward bearing.
  - c. Press against outer rim of oil seal until seal is flush with machined surface of inner primary housing.
6. Lubricate bearing and seal lip with multi-purpose grease or SCREAMIN' EAGLE ASSEMBLY LUBE.

for best results.



1. Retaining ring
2. Oil passage

Figure 5-30. Retaining Ring Orientation

### MAINSHAFT BEARING INNER RACE

| PART NUMBER | TOOLNAME                               |
|-------------|--|
| HD-34902-C  | BEARING RACE REMOVER AND INSTALLER KIT |

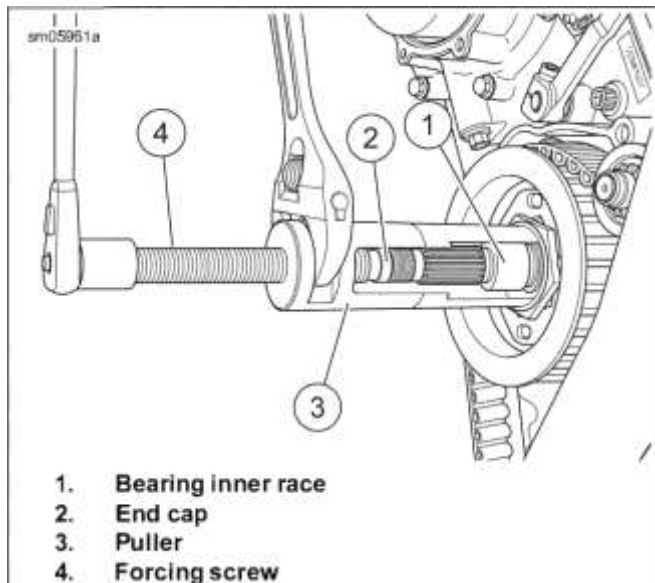
#### Remove

#### NOTE

Use only BEARING RACE REMOVER AND INSTALLER KIT (PART NUMBER: HD-34902-C).

1. See Figure 5-31. Remove bearing inner race.

Special Tool: BEARING RACE REMOVER AND INSTALLER KIT (HD-34902-C)



1. Bearing inner race
2. End cap
3. Puller
4. Forcing screw

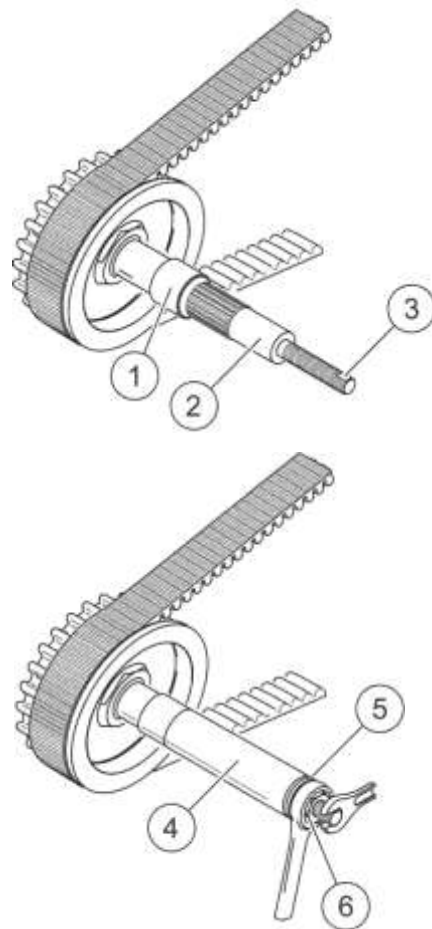
Figure 5-31. Pulling Mainshaft Inner Bearing Race Install

1. See Figure 5-32. Install bearing inner race (1) onto mainshaft.

Special Tool: BEARING RACE REMOVER AND INSTALLER KIT (HD-34902-C)

2. Lubricate race with SCREAMIN' EAGLE ASSEMBLY LUBE.

sm03455



1. Bearing inner race
2. Extension shaft
3. Wrench flat
4. Installer sleeve
5. Washer (2)
6. Nut

Figure 5-32. Installing Bearing Race SHIFTER SHAFT BUSHING

1. See Figure 5-33. Press out old bushing (1) from front to back.
2. Inspect the bushing bore to verify that it is clean and smooth.
3. Press **new** bushing from back of chaincase until it is flush to specification below edge of bore.

Length/Dimension/Distance: 0.020 in (0.51 mm)



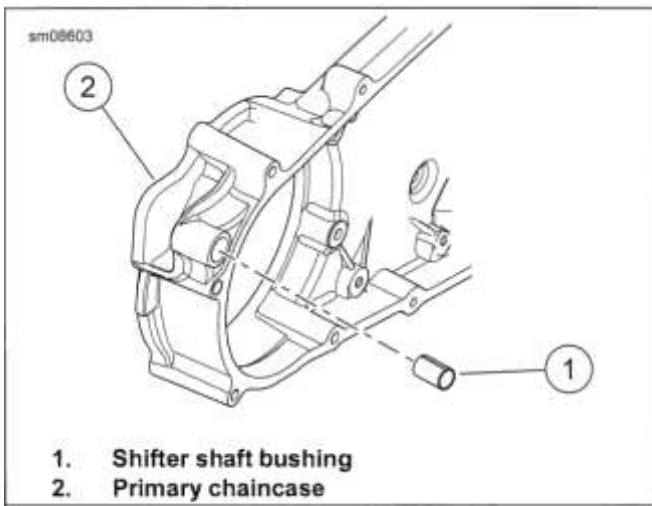


Figure 5-33. Shifter Shaft Bushings

## VENT HOSE

### Remove

1. See Figure 5-35. Cut at vent hose crown (3) and discard.

### Install

1. **NOTE**  
Lubricate hose with a mixture of 50 percent isopropyl alcohol and 50 percent distilled water.

Avoid cutting hose during installation.

See Figure 5-34. Install vent hose.

- a. Route vent hose (2) through vent hole (1).
  - b. See Figure 5-35. Align base of vent hose (4) in case pocket.
  - c. Pull vent hose crown (3) through primary case.
2. Clean off any residual fluid from vent hose installation.

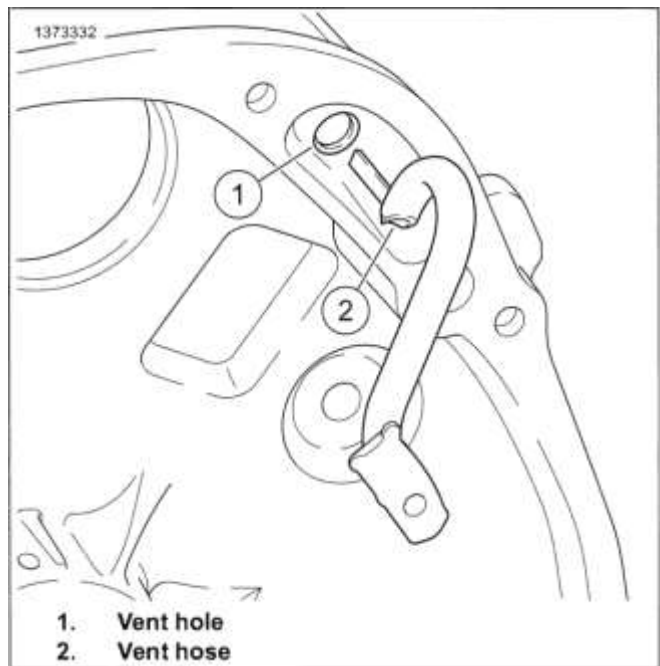


Figure 5-34. Install Vent Hose

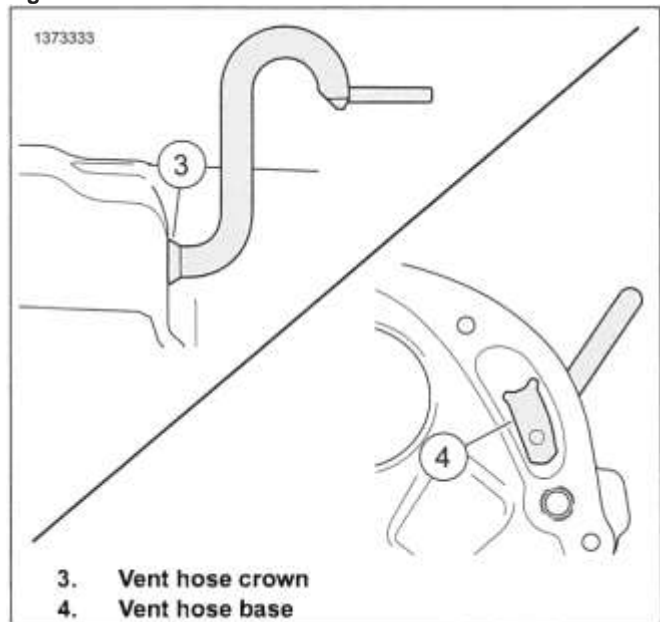


Figure 5-35. Vent Hose Installed

## COMPLETE

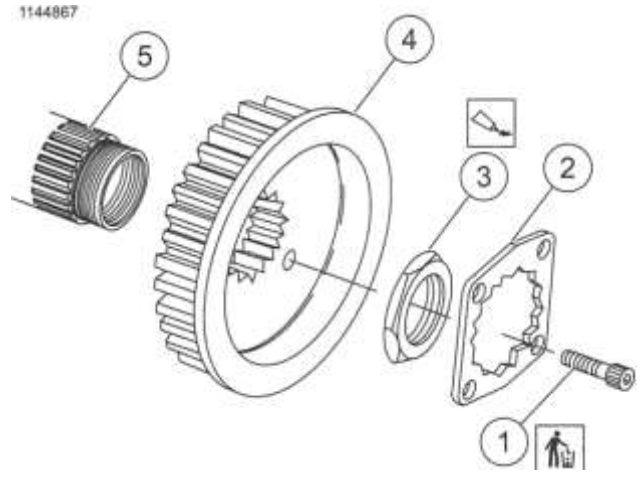
1. Install the primary chain, clutch, compensating sprocket and chain tensioner. See DRIVE COMPONENTS (Page 5-16).
2. Install starter. See STARTER (Page 8-11).
3. Install primary chaincase cover and **new** gasket. See PRIMARY CHAINCASE COVER (Page 5-14).
4. Fill primary chaincase oil. See REPLACE PRIMARY CHAINCASE LUBRICANT (Page 2-11).
5. Install foot shift lever. See SHIFTER LINKAGE (Page 5-7).
6. Install rider left footboard and bracket, if removed. See RIDER FOOTRESTS (Page 3-142).
7. Connect negative battery cable. See POWER DISCONNECT (Page 8-8).

2. See Figure 5-36. Remove sprocket (4), allowing belt to slip from sprocket as sprocket is removed.

**A WARNING**

To prevent accidental vehicle start-up, which could cause death or serious injury, disconnect negative (-) battery cable before proceeding. (00048a)

1. Disconnect negative battery cable. See POWER DISCONNECT (Page 8-8).
2. Remove left footboard and bracket. See RIDER FOOTRESTS (Page 3-142).
3. Remove heel shift lever. See SHIFTER LINKAGE (Page 5-7).
4. Drain primary chaincase oil. See REPLACE PRIMARY CHAINCASE LUBRICANT (Page 2-11).
5. Remove primary chaincase cover. See PRIMARY CHAINCASE COVER (Page 5-14).
6. Remove starter. See STARTER (Page 8-11).
7. Remove primary chain, clutch and compensating sprocket. See DRIVE COMPONENTS (Page 5-16).
8. Remove primary chaincase housing. See PRIMARY CHAINCASE HOUSING (Page 5-25).
9. Loosen drive belt. See INSPECT AND ADJUST DRIVE BELT AND SPROCKETS (Page 2-37).



1. Screw (2)
2. Lockplate
3. Sprocket nut
4. Sprocket
5. Main drive gear

Figure 5-36. Transmission Sprocket

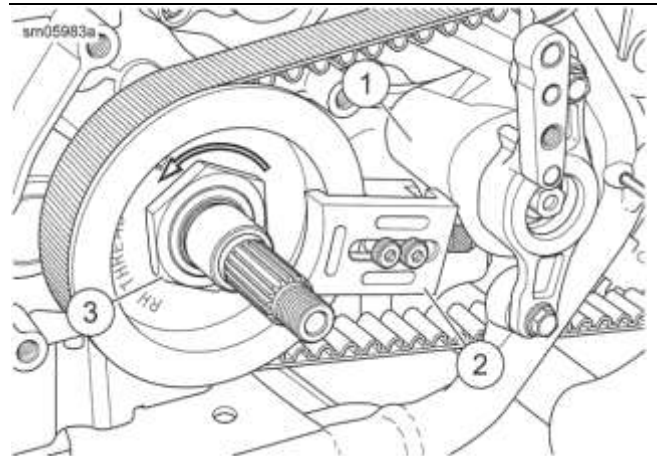
**REMOVE**

| PART NUMBER | TOOLNAME                          |
|-------------|-----------------------------------|
| HD-46282A   | FINAL DRIVE SPROCKET LOCKING TOOL |
| HD-47910    | MAINSHAFT LOCKNUT WRENCH          |
| HD-94660-2  | PILOT                             |

**NOTE**

- Loosen sprocket nut only while transmission is installed in frame. Damage to transmission or transmission stand may result.
- Sprocket nut has **right-hand** threads.

1. See Figure 5-36. Remove sprocket nut.
  - a. Remove and discard screws (1).
  - b. Remove lockplate (2).
- c. See Figure 5-37. Attach sprocket locking tool (2) with arm of tool against bottom of rear fork pivot (1).  
Special Tool: FINAL DRIVE SPROCKET LOCKING TOOL (HD-46282A)
- d. Install pilot on mainshaft.  
Special Tool: PILOT (HD-94660-2)
- e. Remove sprocket nut (3) using locknut wrench.  
Special Tool: MAINSHAFT LOCKNUT WRENCH (HD-47910)



1. Rear fork pivot
2. Final drive sprocket locking tool
3. Sprocket nut

Figure 5-37. Sprocket Nut Removal

**CLEAN AND INSPECT**

1. Using a non-volatile cleaning solvent, clean sprocket of all grease and dirt.
2. Inspect belt and sprocket. See INSPECT AND ADJUST DRIVE BELT AND SPROCKETS (Page 2-37).
3. Inspect main drive gear and mainshaft seals. Replace if damaged.

## INSTALL

| PART NUMBER | TOOL NAME                         |
|-------------|-----------------------------------|
| HD-46282A   | FINAL DRIVE SPROCKET LOCKING TOOL |
| HD-47910    | MAINSHAFT LOCKNUT WRENCH          |
| HD-94660-2  | PILOT                             |
| TA360       | TORQUE ANGLE GAUGE                |

| FASTENER                                | TORQUE VALUE  |               |
|---|---------------|---------------|
| Transmission sprocket lock-plate screws | 90-120 in-lbs | 10.2-13.6 N-m |
| Transmission sprocket nut, 1st torque   | 100 ft-lbs    | 135.6 N-m     |
| Transmission sprocket nut, 2nd torque   | 35 ft-lbs     | 47.5 N-m      |
| Transmission sprocket nut, final torque |               | 35-40°        |

| PART NUMBER | CONSUMABLE   |
|-------------|--|
| Loctite 271 | LOCTITE 271 HIGH STRENGTH THREADLOCKER AND SEALANT (RED) |

### NOTE

- Tighten sprocket nut only while transmission is installed in frame. Damage to transmission or transmission stand may result.

1. Place transmission sprocket in position. Install belt as sprocket is installed.
2. Install sprocket nut.

### NOTE

Transmission sprocket nut has **right-hand** threads.

- a. See Figure 5-36. Apply a film of clean engine oil to mating surfaces of sprocket nut (3) and sprocket (4).

### NOTE

Never get oil on sprocket nut threads.

- b. If reusing sprocket nut, apply threadlocker to threads of sprocket nut.

LOCTITE 271 HIGH STRENGTH THREADLOCKER AND SEALANT (RED) (Loctite 271)

- c. Install sprocket nut finger-tight.
- d. See Figure 5-38. Install sprocket locking tool (2) against rear fork pivot (3).

Special Tool: FINAL DRIVE SPROCKET LOCKING TOOL (HD-46282A)

- e. Install pilot on mainshaft.  
Special Tool: PILOT (HD-94660-2)

- f. Tighten sprocket nut (3) Using locking wrench.

Torque: 100 ft-lbs (135.6 N-m) *Transmission sprocket nut, 1st torque*

Special Tool: MAINSHAFT LOCKNUT WRENCH (HD-47910)

3. Loosen sprocket nut one full turn.
4. Tighten sprocket nut.  
Torque: 35 ft-lbs (47.5 N-m) *Transmission sprocket nut, 2nd torque*
5. See Figure 5-39. Scribe lines (3) or use torque angle gauge for final torque.

Special Tool: TORQUE ANGLE GAUGE (TA360)

6. Tighten sprocket nut an additional.  
Torque: (35-40°) *Transmission sprocket nut, final torque*

### NOTE

- Lockplate can be installed either side out.
  - Never LOOSEN nut to align screw holes.
  - If necessary, tighten nut slightly to align lockplate.
  - Do not exceed final torque of 45 degrees.
7. Install lockplate.
    - a. See Figure 5-36. Align lockplate (2) holes with tapped holes in sprocket (4).
    - b. Install new screws (1).
    - c. Tighten.

Torque: 90-120 in-lbs (10.2-13.6 N-m) *Transmission sprocket lockplate screws*

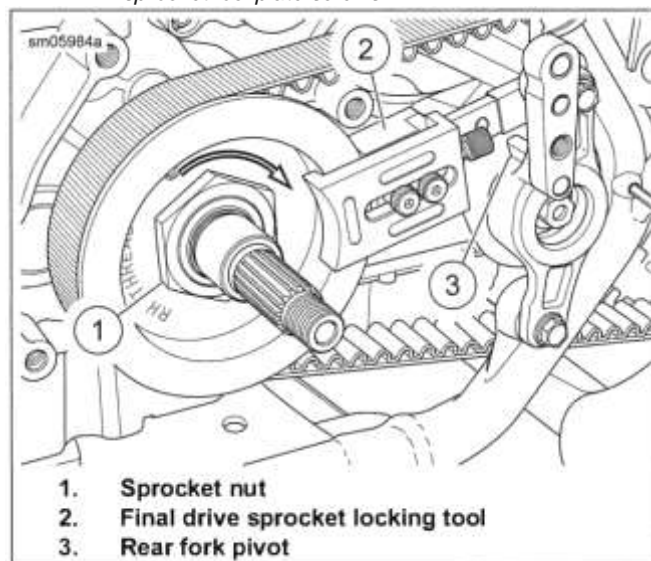


Figure 5-38. Sprocket Nut Installation

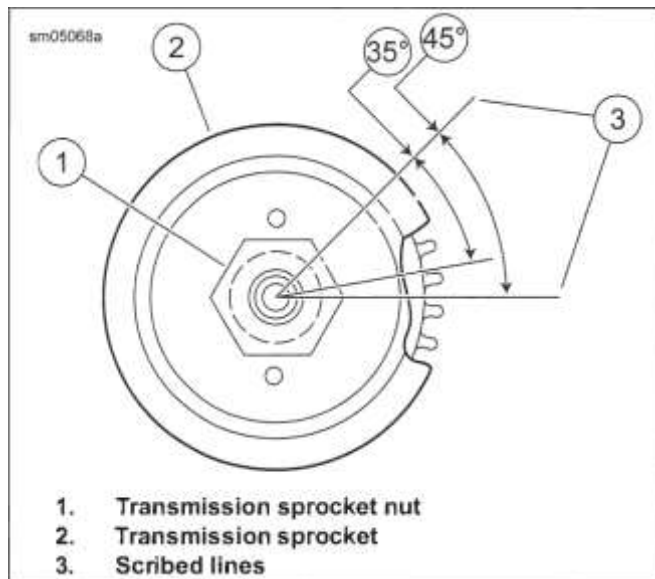


Figure 5-39. Transmission Sprocket Nut Final Tightening

**COMPLETE**

1. Install primary chaincase housing. See PRIMARY CHAINCASE HOUSING (Page 5-25).
2. Install the primary chain, clutch, compensating sprocket and chain tensioner. See DRIVE COMPONENTS (Page 5-16).
3. Install starter. See STARTER (Page 8-11).
4. Install primary chaincase cover and new gasket. See PRIMARY CHAINCASE COVER (Page 5-14).
5. Fill primary chaincase oil. See REPLACE PRIMARY CHAINCASE LUBRICANT (Page 2-11).
6. Install heel shift lever. See SHIFTER LINKAGE (Page 5-7).
7. Install rider left footboard and bracket. See RIDER FOOTRESTS (Page 3-142).
8. Adjust drive belt deflection. See INSPECT AND ADJUST DRIVE BELT AND SPROCKETS (Page 2-37).
9. Verify rear fork pivot shaft torque. See REAR FORK (Page 3-75).
10. Connect negative battery cable. See POWER DISCONNECT (Page 8-8).

**PREPARE****A WARNING**

To prevent accidental vehicle start-up, which could cause death or serious injury, disconnect negative (■) battery cable before proceeding. (00048a)

1. Disconnect negative battery cable. See POWER DISCONNECT (Page 8-8).
2. Drain transmission oil. See REPLACE TRANSMISSION LUBRICANT (Page 2-13).
3. Drain engine oil. See REPLACE ENGINE OIL AND FILTER (Page 2-9).
4. Remove exhaust system. See EXHAUST SYSTEM (Page 6-34).
5. Remove clutch release cover. See CLUTCH RELEASE COVER (Page 5-9).
6. Remove clutch release push rod. See CLUTCH RELEASE PUSH ROD COMPONENTS (Page 5-12).
7. Remove rider footboard and bracket, if needed. See RIDER FOOTRESTS (Page 3-142).
8. Remove heel shift lever. See SHIFTER LINKAGE (Page 5-7).
9. Drain primary chaincase oil. See REPLACE PRIMARY CHAINCASE LUBRICANT (Page 2-11).
10. Remove primary chaincase cover. See PRIMARY CHAINCASE COVER (Page 5-14).
11. Remove starter. See STARTER (Page 8-11).
12. Remove primary chain, clutch and compensating sprocket. See DRIVE COMPONENTS (Page 5-16).
13. Remove primary chaincase housing. See PRIMARY CHAINCASE HOUSING (Page 5-25).
14. Loosen drive belt. See INSPECT AND ADJUST DRIVE BELT AND SPROCKETS (Page 2-37).
15. Remove transmission mainshaft bearing inner race. See Mainshaft Bearing Inner Race (Page 5-27).

**REMOVE****NOTE**

Do not remove transmission case unless case requires replacement. See TRANSMISSION CASE (Page 5-47).

1. Remove transmission top cover.
2. See Figure 5-40. Set a rag over transmission case.
3. Set shifter cam pawl (1) on rag.
4. Cover mainshaft clutch hub splines with tape to prevent damaging main drive gear bearings and oil seal.

**NOTE**

See Figure 5-41. Always pry bearing housing loose. Never tap on shafts to remove transmission assembly. The bearing housing bearings will be damaged.

5. See Figure 5-42. Remove transmission and bearing housing assembly.
  - a. Remove transmission bearing housing screws (1).
  - b. See Figure 5-41. Pry bearing housing loose.
  - c. Remove bearing housing and transmission components from transmission case as an assembly.

**INSTALL**

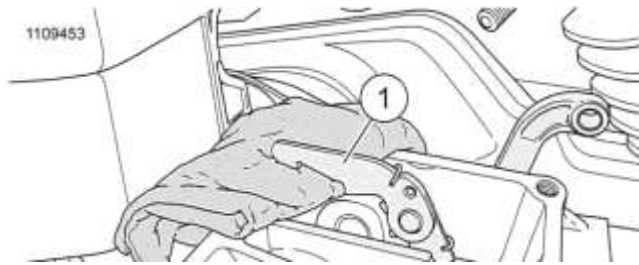
| FASTENER                           | TORQUE VALUE   |               |
|------------------------------------|----------------|---------------|
| Transmission bearing housing screw | 22-25 ft-lbs   | 29.8-33.9 N-m |
| Transmission top cover screw       | 132-156 in-lbs | 14.9-17.6 N-m |

1. Cover mainshaft clutch hub splines with tape to prevent damaging main drive gear bearings and oil seal.
2. Install a new gasket on transmission assembly ring dowels.
3. Apply clean transmission lubricant to main drive gear bearings.

**NOTE**

Verify transmission filler plug/dipstick is removed.

4. Install transmission assembly in transmission case.
5. See Figure 5-42. Install transmission bearing housing.
  - a. Install screws (1).
  - b. See Figure 5-43. Tighten in sequence.  
Torque: 22-25 ft-lbs (29.8-33.9 N-m) *Transmission bearing housing screw*
6. Install top cover.
  - a. Set shifter cam pawl on shift cam.
  - b. Inspect transmission top cover gasket. Replace as necessary.
  - c. Install transmission top cover and screws. Tighten.  
Torque: 132-156 in-lbs (14.9-17.6 N-m) *Transmission top cover screw*
7. Install vent hose to top cover fitting, if removed.



1. Shifter pawl
2. Rag

Figure 5-40. Transmission Shifter Pawl

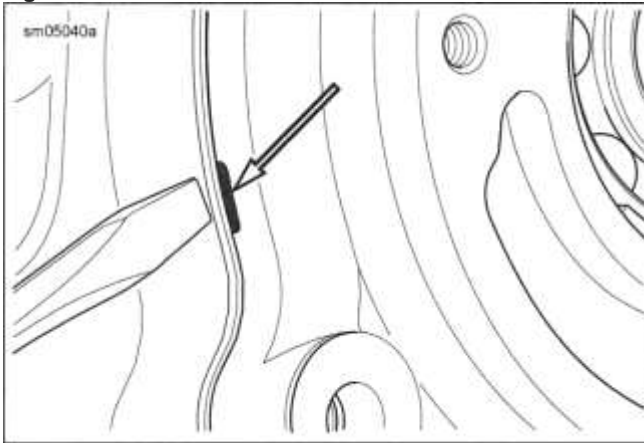
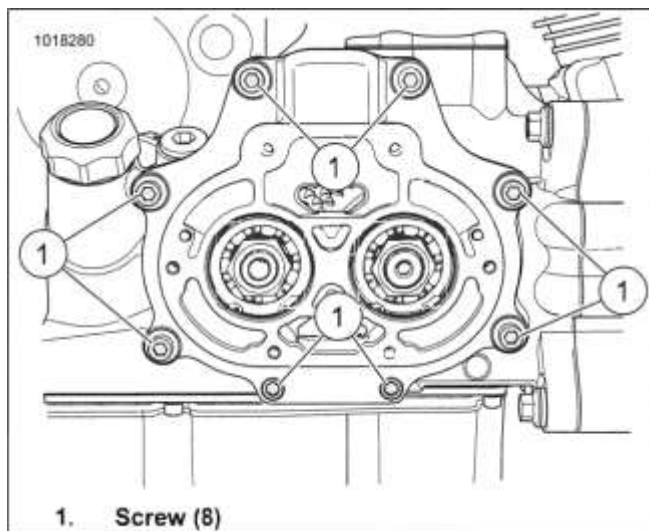


Figure 5-41. Bearing Housing Pry Point



1. Screw (8)

Figure 5-42. Bearing Housing Screws

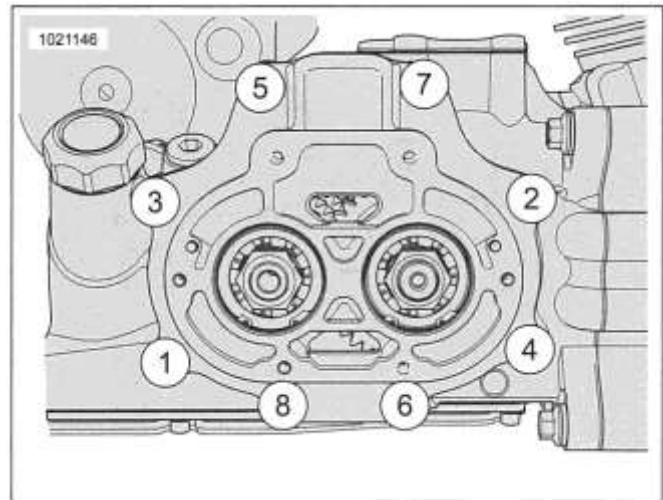


Figure 5-43. Transmission Bearing Housing Tightening Sequence

### DISASSEMBLE

#### Remove Shift Cam and Shifter Forks

1. See Figure 5-44. Remove shift fork shafts.
  - a. Set bearing housing on bench with shafts pointing up.

#### NOTE

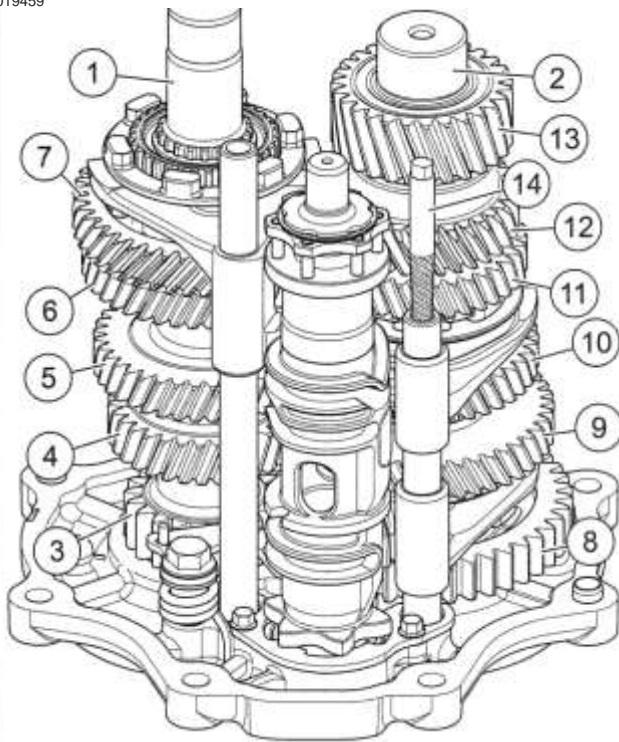
Shafts have slight interference fit.

- b. Remove shift fork shafts using spiral-flute screw extractor (14) or vise grips.
  - c. Mark end of shaft to aid assembly.
2. Remove shift forks from dog rings.
  3. See Figure 5-45. Remove lock plate (2). Discard screws (3).
  4. Hold detent arm back and remove shift cam (4).
  5. See Figure 5-46. If needed, remove detent assembly.
    - a. Remove detent screw (1), detent arm (2), sleeve (3) and detent spring (4).
    - b. Discard detent screw.

#### NOTE

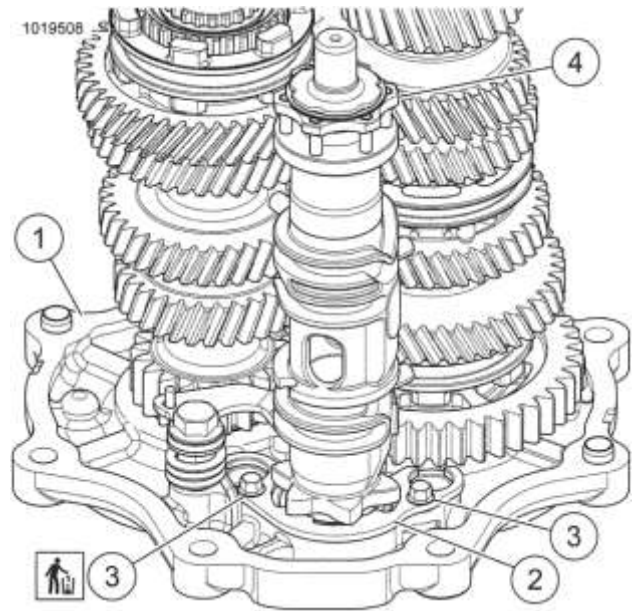
Mark parts so they can be installed in same direction as removed.

6. See Figure 5-47. Remove mainshaft and countershaft locknuts.
  - a. Lock two gears in place using dog rings.
  - b. Temporarily put transmission assembly into transmission case.
    - c. Remove locknuts.
    - d. Remove transmission assembly from transmission case.



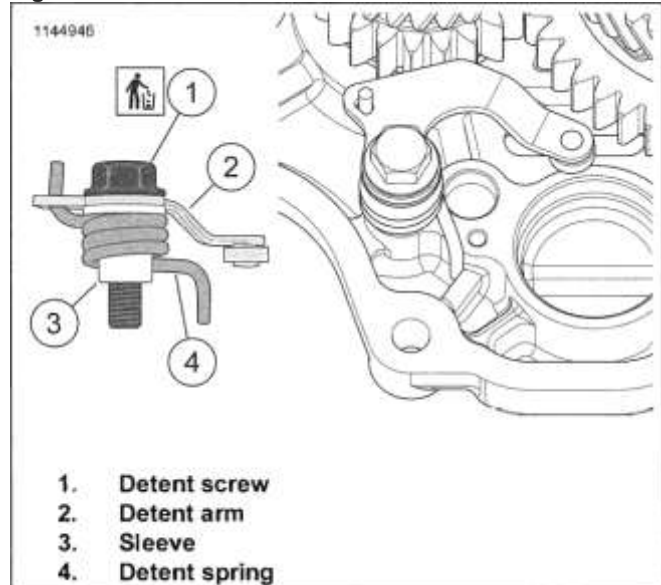
- 1. Mainshaft
- 2. Countershaft
- 3. Mainshaft first gear
- 4. Mainshaft second gear
- 5. Mainshaft third gear
- 6. Mainshaft fourth gear
- 7. Mainshaft fifth gear
- 8. Countershaft first gear
- 9. Countershaft second gear
- 10. Countershaft third gear
- 11. Countershaft fourth gear
- 12. Countershaft fifth gear
- 13. Countershaft sixth gear
- 14. Screw extractor

Figure 5-44. Gear Set



- 1. Bearing housing
- 2. Lock plate
- 3. Lock plate screw (2)
- 4. Shift cam

Figure 5-45. Shift Drum



- 1. Detent screw
- 2. Detent arm
- 3. Sleeve
- 4. Detent spring

Figure 5-46. Detent Assembly

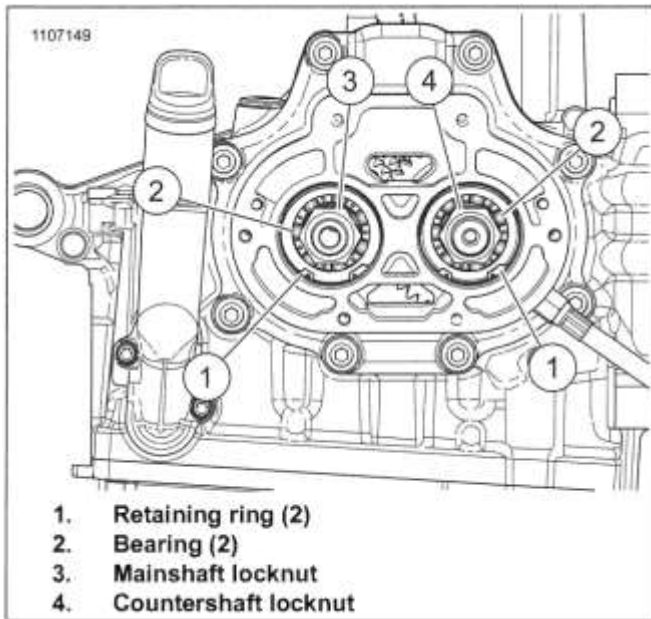


Figure 5-47. Bearing Housing Locknuts

### Remove Mainshaft

**NOTE**

- Mainshaft fourth gear, third gear, second gear and first gear are integral parts of the shaft. Damage to any gear requires mainshaft replacement.
- Always replace bearing housing bearings.

1. See Figure 5-48. Remove retaining ring.
2. Remove dog ring (3), guiding hub (2), mainshaft fifth gear (4) and bearing.

**NOTE**

Do not press directly on end of mainshaft. Use a spacer between end of mainshaft and press ram.

3. Press mainshaft out of bearing housing.
4. Replace bearing housing bearing. See procedure later in this section.

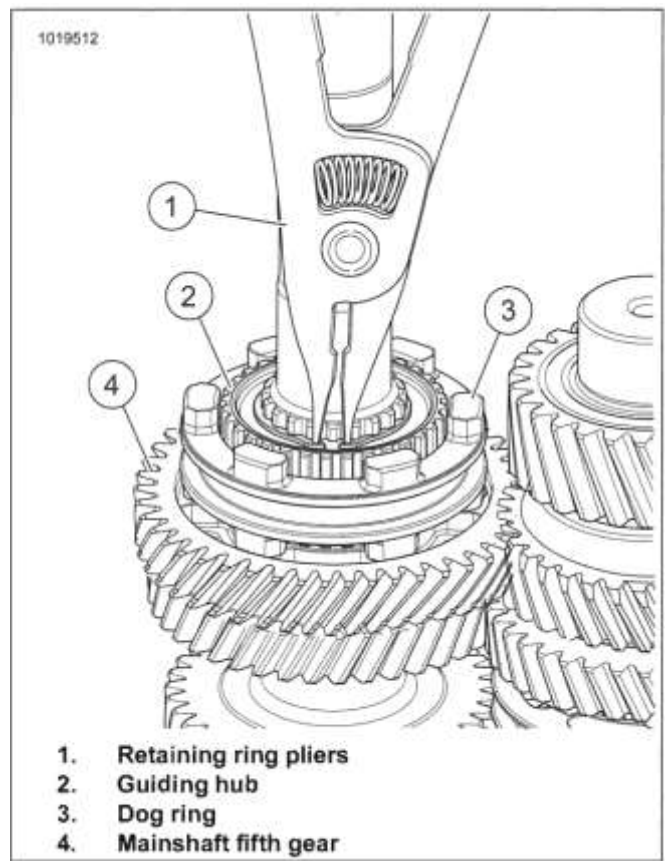


Figure 5-48. Mainshaft Fifth Gear

### Remove Countershaft

**NOTE**

Do not press directly on end of countershaft. Place a spacer between end of countershaft and press ram.

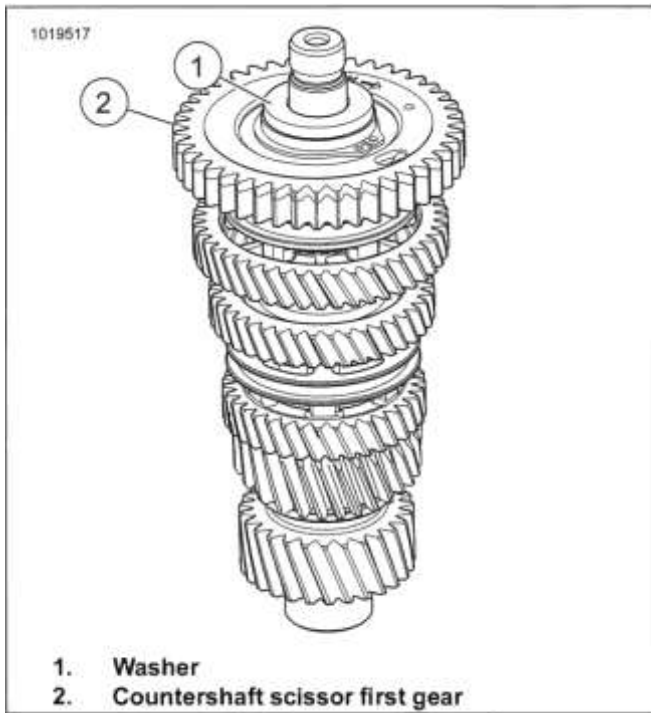
1. If mainshaft is not removed, hold countershaft third and fourth gear shift dog up while removing countershaft.
2. Press countershaft out of bearing housing bearing.
3. See Figure 5-49. Remove washer (1), countershaft first gear (2) and bearing.
4. Remove countershaft second, third and fourth gears.
  - a. See Figure 5-50. Remove dog ring (5).
  - b. Remove lock ring (1).
  - c. Remove securing segments (2).
  - d. Remove guiding hub (3), countershaft second gear (4) and bearing.
  - e. See Figure 5-51 and Figure 5-52. Repeat steps with third and fourth gears.

**NOTE**

The countershaft fifth gear and sixth gear are integral parts of the shaft. Damage to either gear requires countershaft replacement.

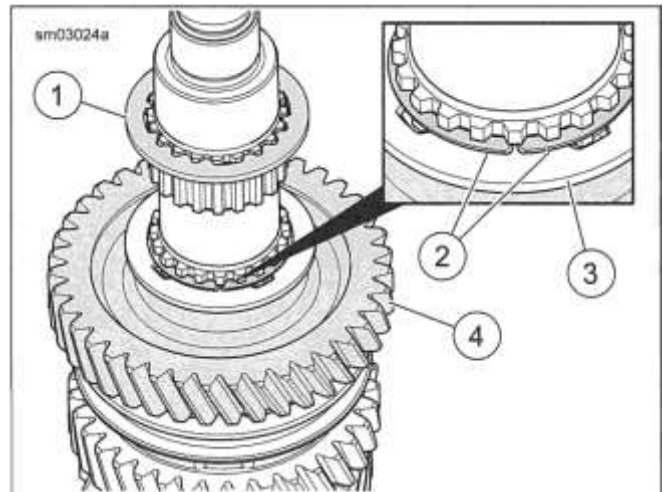
5. Replace bearing housing bearing. See procedure later in this section.





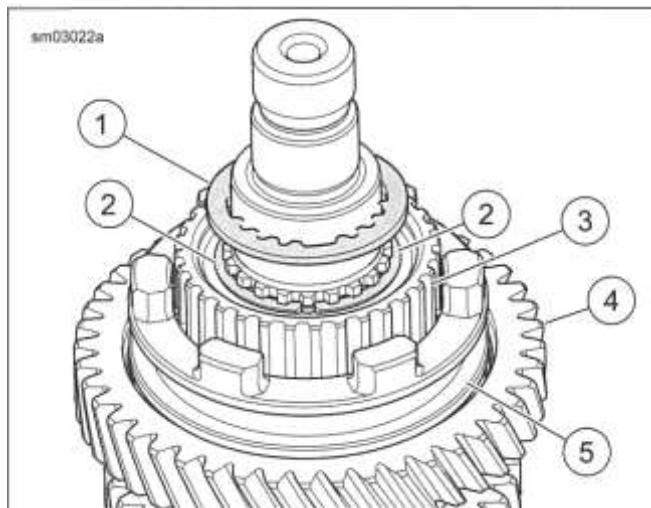
1. Washer
2. Countershaft scissor first gear

Figure 5-49. Countershaft First Gear



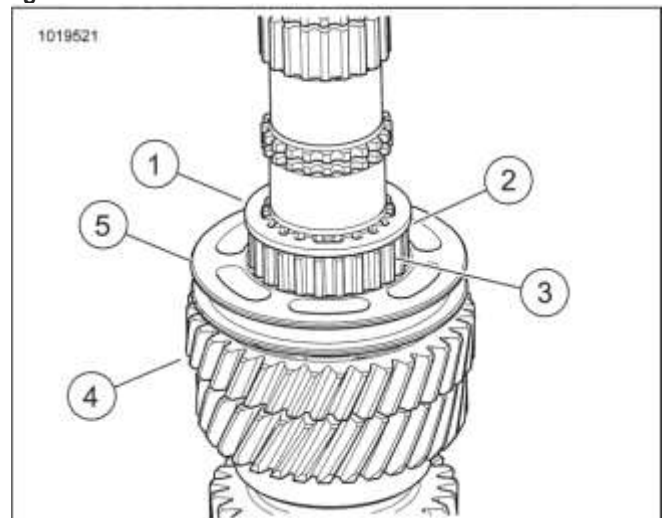
1. Lock ring
2. Securing segment (2)
3. Internal spline washer
4. Countershaft third gear

Figure 5-51. Countershaft Third Gear



1. Lock ring
2. Securing segment (2)
3. Guiding hub
4. Countershaft second gear
5. Dog ring

Figure 5-50. Countershaft Second Gear



1. Lock ring
2. Securing segment (2) (not visible)
3. Guiding hub
4. Countershaft fourth gear
5. Dog ring

Figure 5-52. Countershaft Fourth Gear

### Remove Bearing Housing Bearings

*NOTE*

*Always replace bearing housing bearing if shaft is pressed out.*

1. See Figure 5-53. Remove and discard retaining rings (2).
2. Press bearings out of bearing housing.

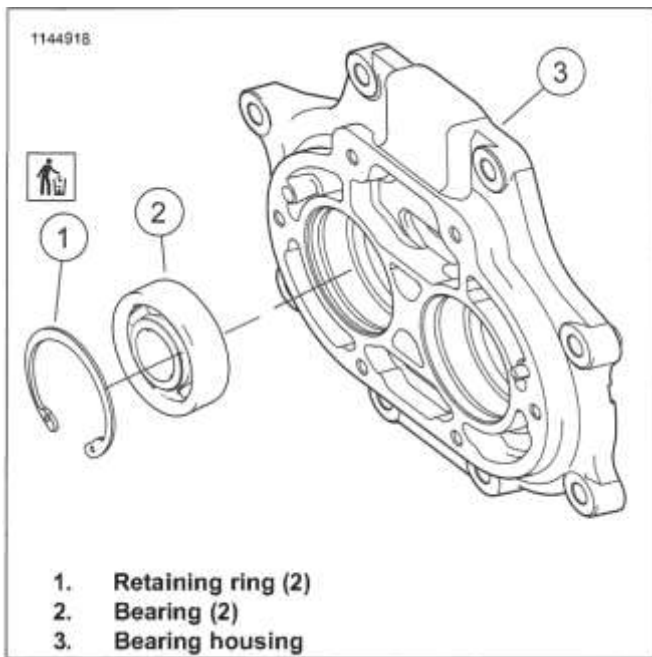


Figure 5-53. Bearing Housing Bearings

## CLEAN AND INSPECT

### A WARNING

Compressed air can pierce the skin and flying debris from compressed air could cause serious eye injury. Wear safety glasses when working with compressed air. Never use your hand to check for air leaks or to determine air flow rates. (00061a)

1. Clean parts in a non-volatile cleaning solution. Dry parts with low-pressure, compressed air.
2. Replace worn or damaged gears.
3. Replace dog rings if dogs and/or pockets are rounded, battered or chipped.
4. Replace guiding hubs if splines are rounded, battered or chipped.
5. Replace bent or damaged shift fork shafts.
6. Replace shift fork if it is excessively worn or shows signs of overheating.
7. See Figure 5-54. Using a small square, verify that the shift forks are square. Replace shift fork if not square.
8. Replace shift drum assembly if drum or bearing are damaged.
9. Clean shift cam lock plate mounting holes in transmission bearing housing.

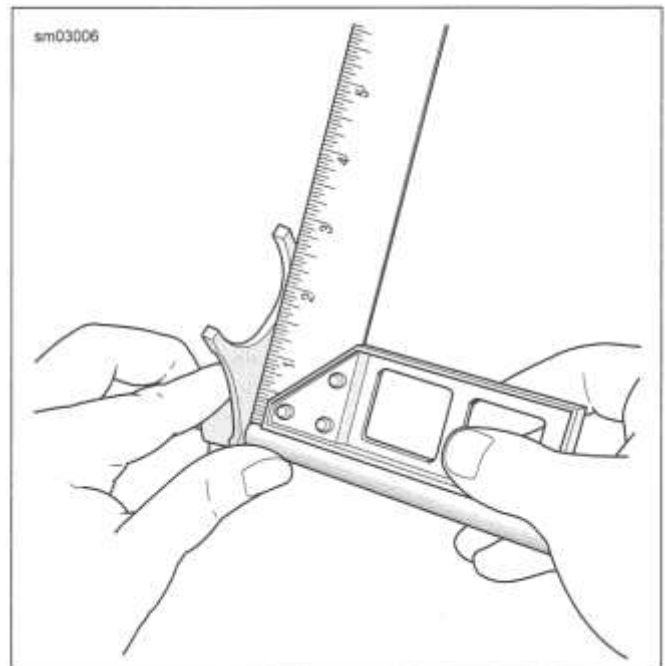


Figure 5-54. Checking Fork

## ASSEMBLE

| FASTENER                                     | TORQUE VALUE   |               |
|--|----------------|---------------|
| Shift drum detent screw                      | 120-150 in-lbs | 13.6—17 N-m   |
| Shift drum lock plate screws                 | 57-63 in-lbs   | 6.4-7.1 N-m   |
| Transmission mainshaft/countershaft locknuts | 85—195 ft-lbs  | 115.3-128.8Nm |

## Install Bearing Housing Bearings

### NOTE

- Always replace bearing housing bearing if shaft was removed.
- Always support bearing housing with a plate when pressing bearings.
- Press on bearing outer race.

1. Install bearings.
  - a. Support bearing housing at bearing bores with a flat plate.
  - b. Position new bearing over bore with number side up.
  - c. Press bearing until seated in bore.

### A WARNING

Wear safety glasses or goggles when removing or installing retaining rings. Retaining rings can slip from the pliers and could be propelled with enough force to cause serious eye injury. (00312a)

2. See Figure 5-53. Install new beveled retaining ring (1) with flat side against bearing.

## Install Countershaft

1. Install fourth, third and second gears on countershaft.
  - a. See Figure 5-52. Install countershaft fourth gear (4).
  - b. Lubricate needle bearings and races using SCREAM I N' EAGLE ASSEMBLY LUBE.
  - c. Install **new** needle bearing.
  - d. Install guiding hub (3).
  - e. Install dog ring (5).
  - f. Install securing segments (2) with rounded edge facing up. Verify that segments fully engage grooves in countershaft.
  - g. Install lock ring (1) with waved, stepped face toward securing segments.
  - h. See Figure 5-51. Install countershaft third gear (4).

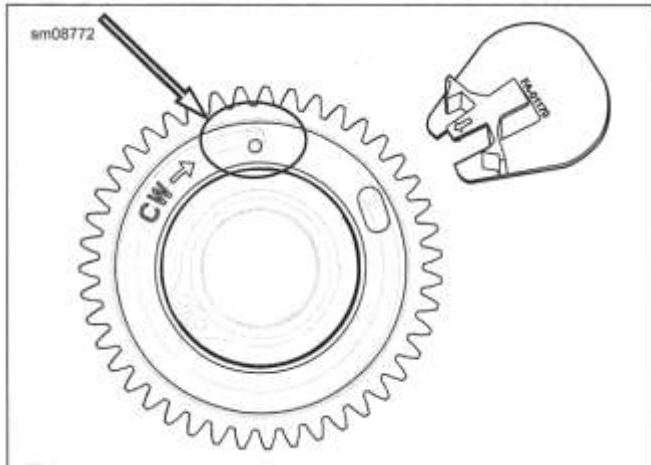
**NOTE**

*Install second gear guiding hub with deeper counterbore facing countershaft second gear.*

- i. See Figure 5-50. Install countershaft second gear (4).
2. See Figure 5-55. Preload scissor first gear.
    - a. While holding thick gear, rotate thin gear until holes align.
    - b. Install HD-52235 (SCISSOR FIRST GEAR TOOL).
  3. See Figure 5-49. Install **new** needle bearing, countershaft first gear (2) and washer (1).

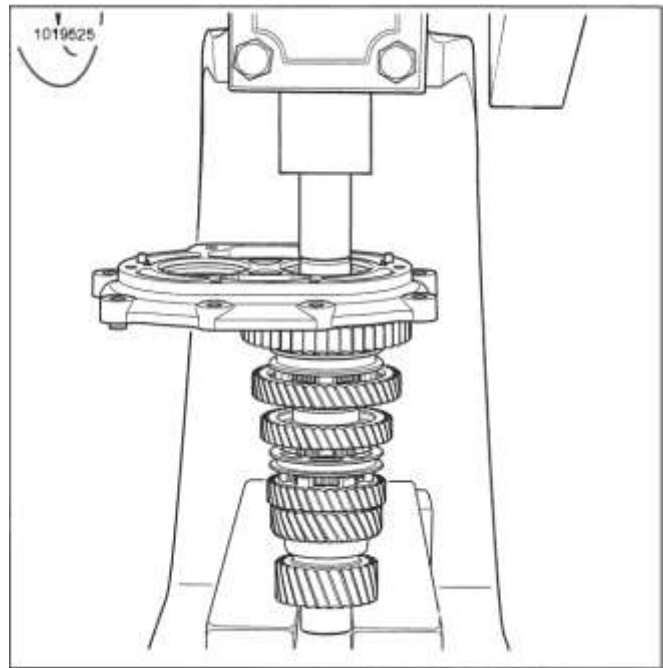
**NOTE**

- *If installing countershaft with mainshaft installed, raise and hold countershaft third and fourth gear shift dog up while pressing bearing housing bearing on to countershaft.*
  - *Failure to press on bearing inner race damages bearing.*
4. See Figure 5-57. If mainshaft is not removed, raise and hold countershaft third and fourth gear shift dog while installing countershaft.
  5. See Figure 5-56. Install countershaft to bearing housing.
    - a. Support countershaft sixth gear in press.
    - b. Using a suitable sleeve, press on bearing inner race until bearing contacts countershaft first gear washer.



**Figure 5-55. Preload Scissor First Gear**

1. Support mainshaft fourth gear in press.
2. See Figure 5-57. Raise and hold dog ring engaged with



**Figure 5-56. Installing Countershaft Install Mainshaft**

**NOTE**

*Failure to press on bearing inner race damages bearing. countershaft third gear during press procedure.*

3. Using a suitable sleeve, press on bearing inner race until bearing contacts mainshaft first gear.
4. See Figure 5-48. With bearing housing on end (shafts pointing up), install **new** bearing and mainshaft fifth gear (4).
5. With guiding hub counterbore facing mainshaft fifth gear, install guiding hub (2) and dog ring (3).
6. Install **new** retaining ring (1).
7. Remove holding tool from scissor first gear.
8. Install **new** mainshaft and countershaft locknuts.

Using dog rings, lock two gears in place.

Temporarily install transmission assembly in transmission case.

- c. Install locknuts. Tighten.
 

Torque: 85-95 ft-lbs (115.3-128.8 N-m)  
*Transmission mainshaft/countershaft locknuts*

  - a. d. Remove transmission assembly from transmission case.
  - b.

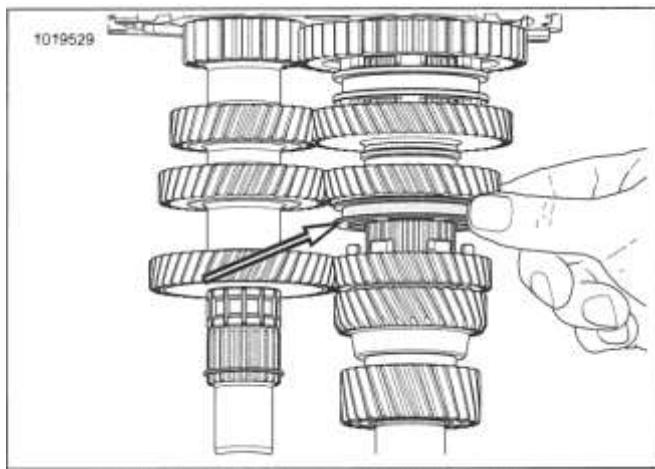


Figure 5-57. Raise and Hold Dog Ring

### Install Shifter Cam/Shifter Forks

1. Set bearing housing on bench with shafts pointing up.
2. Install detent arm assembly, if removed.
  - a. See Figure 5-58. Clean detent screw mounting hole in transmission bearing housing.
  - b. Assemble **new** detent screw (1), detent arm (2), sleeve (3) and detent spring (4).
  - c. Align spring and detent arm as shown.
  - d. Install detent assembly in bearing housing with screw (1).
  - e. Tighten.  
Torque: 120-150 **in-lbs** (13.6-17 N-m) *Shift drum detent screw*
3. See Figure 5-59. Hold detent arm back and install shift cam assembly (4).
4. Install lock plate (2) and **new** lock plate screws (3). Tighten.  
Torque: 57-63 **in-lbs** (6.4-7.1 N-m) *Shift drum lock plate screws*
5. Remove any burrs created on shift shafts (1, 3) during removal.

#### NOTE

See Figure 5-60. Shifter forks are unique and identified as shown.

6. See Figure 5-61. Install long shift shaft (1).
  - a. Insert shifter fork (2) into dog ring between mainshaft fifth and sixth gear.
  - b. Slide shift shaft through shifter fork.
  - c. Install shaft in bearing housing.
7. Install short shift shaft (4).
  - a. Insert shifter fork (6) into dog ring between countershaft third and fourth gear.

- b. Insert shifter fork (9) into dog ring between countershaft first and second gear.
- c. Slide shift shaft through shifter forks.
- d. Install shaft in bearing housing.

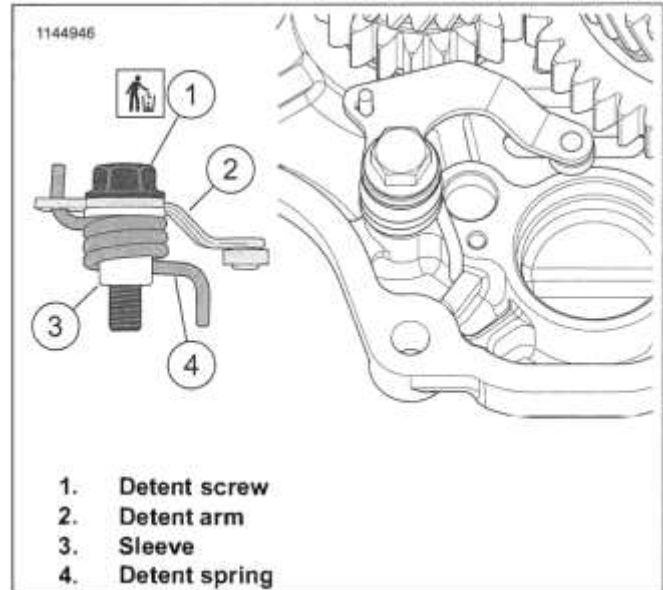


Figure 5-58. Detent Assembly

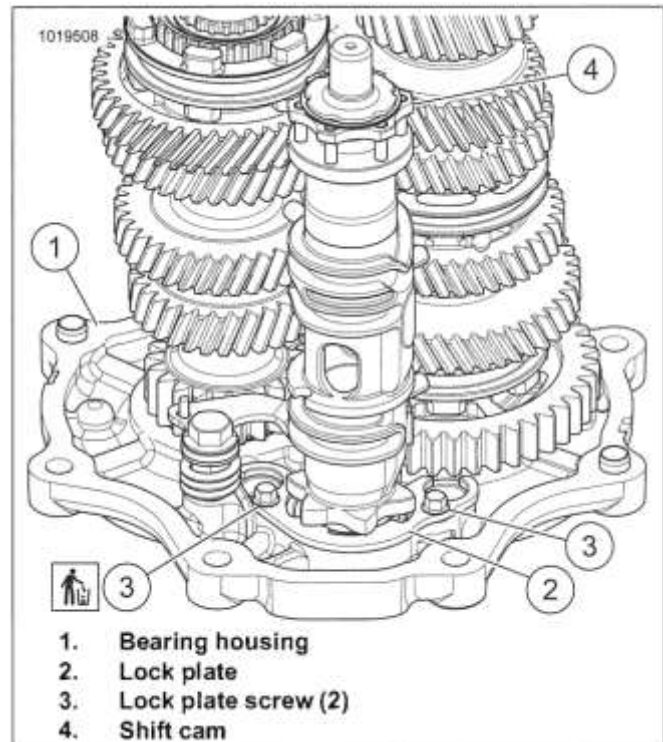
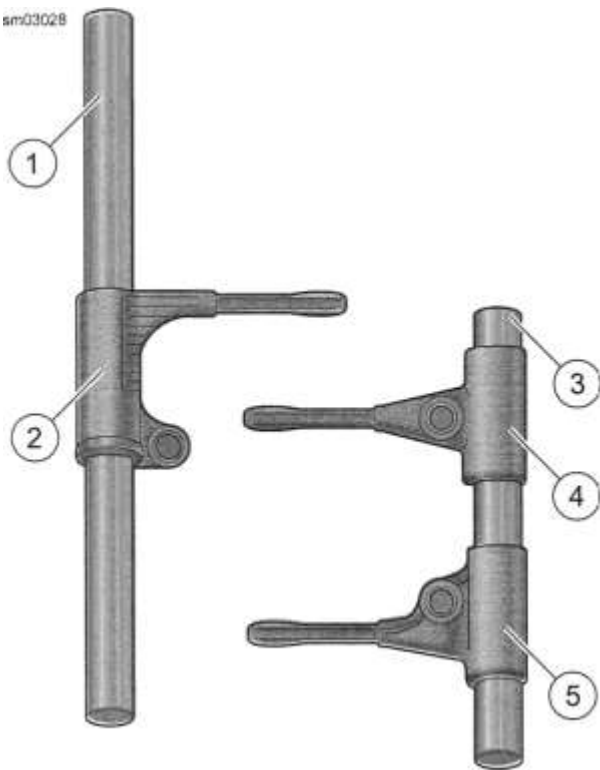


Figure 5-59. Shift Drum

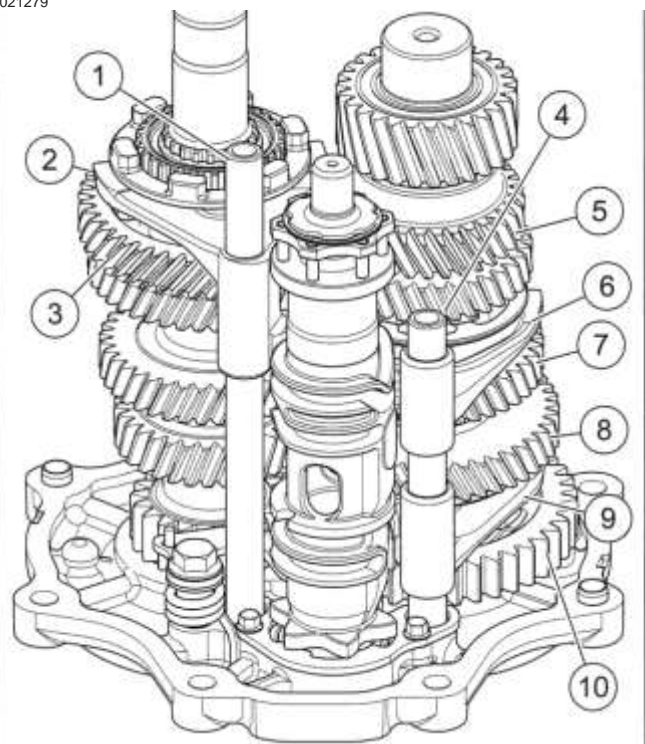


1. Long shift shaft
  2. Fifth and sixth gear shifter fork
  3. Short shift shaft
  4. Third and fourth gear shifter fork
  5. First and second gear shifter fork
- Figure 5-60. Shifter Forks and Shafts

1. Long shift shaft
2. Fifth and sixth gear shifter fork
3. Mainshaft fifth gear
4. Short shift shaft
5. Countershaft fifth gear
6. Third and fourth gear shifter fork
7. Third gear
8. Second gear
9. First and second gear shifter fork
10. First gear

Figure 5-61. Transmission Gears and Shifter Forks

**COMPLETE**



1. Install transmission mainshaft bearing inner race. See Mainshaft Bearing Inner Race (Page 5-27).
2. Install clutch release push rod. See CLUTCH RELEASE PUSH ROD COMPONENTS (Page 5-12).
3. Install clutch release cover. See CLUTCH RELEASE COVER (Page 5-9).
4. Fill transmission oil. See REPLACE TRANSMISSION LUBRICANT (Page 2-13).
5. Fill engine oil. See REPLACE ENGINE OIL AND FILTER (Page 2-9).
6. Install exhaust system. See EXHAUST SYSTEM (Page 6-34).
7. Install primary chaincase housing. See PRIMARY CHAINCASE HOUSING (Page 5-25).
8. Install the primary chain, clutch, compensating sprocket and chain tensioner. See DRIVE COMPONENTS (Page 5-16).
9. Install starter. See STARTER (Page 8-11).
10. Install primary chaincase cover. See PRIMARY CHAINCASE COVER (Page 5-14).
11. Fill primary chaincase oil. See REPLACE PRIMARY CHAINCASE LUBRICANT (Page 2-11).

12. Install heel shift lever. See SHIFTER LINKAGE (Page 5-7).
13. Install rider left footboard and bracket, if removed. See RIDER FOOTRESTS (Page 3-142).
14. Adjust drive belt deflection. See INSPECT AND ADJUST DRIVE BELT AND SPROCKETS (Page 2-37).
15. Verify rear fork pivot shaft torque. See REAR FORK (Page 3-75).
16. Connect negative battery cable. See POWER DISCONNECT (Page 8-8).

## PREPARE

### A WARNING

To prevent accidental vehicle start-up, which could cause death or serious injury, disconnect negative (-) battery cable before proceeding. (00048a)

1. Disconnect negative battery cable. See POWER DISCONNECT (Page 8-8).
2. Remove rider footboard and bracket, if needed. See RIDER FOOTRESTS (Page 3-142).
3. Remove heel shift lever. See SHIFTER LINKAGE (Page 5-7).
4. Drain primary chaincase oil. See REPLACE PRIMARY CHAINCASE LUBRICANT (Page 2-11).
5. Remove primary chaincase cover. See PRIMARY CHAINCASE COVER (Page 5-14).
6. Remove starter. See STARTER (Page 8-11).
7. Remove primary chain, clutch and compensating sprocket. See DRIVE COMPONENTS (Page 5-16).
8. Remove primary chaincase housing. See PRIMARY CHAINCASE HOUSING (Page 5-25).
9. Remove bearing inner race from transmission mainshaft. See Mainshaft Bearing Inner Race (Page 5-27).
10. Remove transmission sprocket. See TRANSMISSION SPROCKET (Page 5-29).
11. Remove transmission bearing housing and gear assembly. See TRANSMISSION (Page 5-32).

## REMOVE

| PART NUMBER | TOOL NAME                                 |
|-------------|---|
| HD-35316-D  | MAIN DRIVE GEAR REMOVER AND INSTALLER SET |

### NOTICE

Failure to use Main Drive Gear Remover and Installer can cause premature failure of bearing and related parts. (00540b)

### NOTE

Main drive gear and bearing can be removed with transmission case in frame after removing bearing housing.

1. See Figure 5-62. Remove main drive gear.  
Special Tool: MAIN DRIVE GEAR REMOVER AND INSTALLER SET (HD-35316-D)
2. See Figure 5-63. Remove and discard main drive gear oil seal (4).
3. Remove and discard retaining ring (3).
4. Remove and discard main drive gear bearing (2).  
Special Tool: MAIN DRIVE GEAR REMOVER AND INSTALLER SET (HD-35316-D)

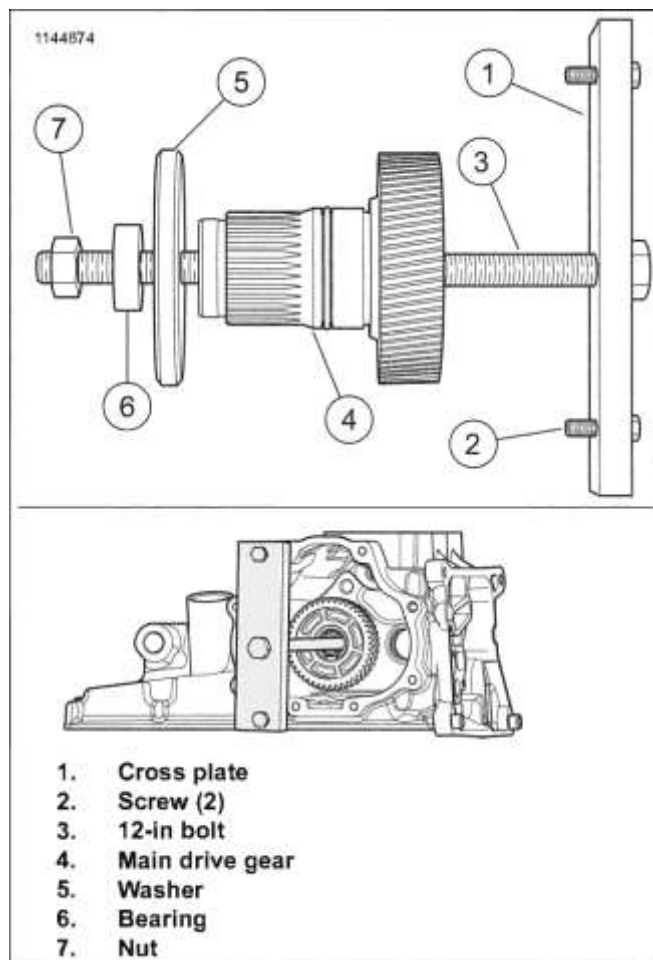


Figure 5-62. Removing Main Drive Gear

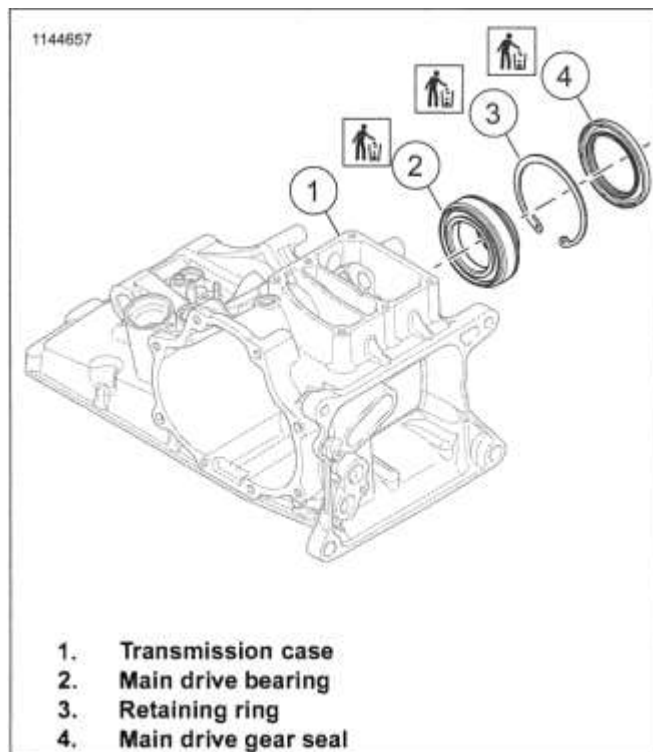


Figure 5-63. Main Drive Bearing

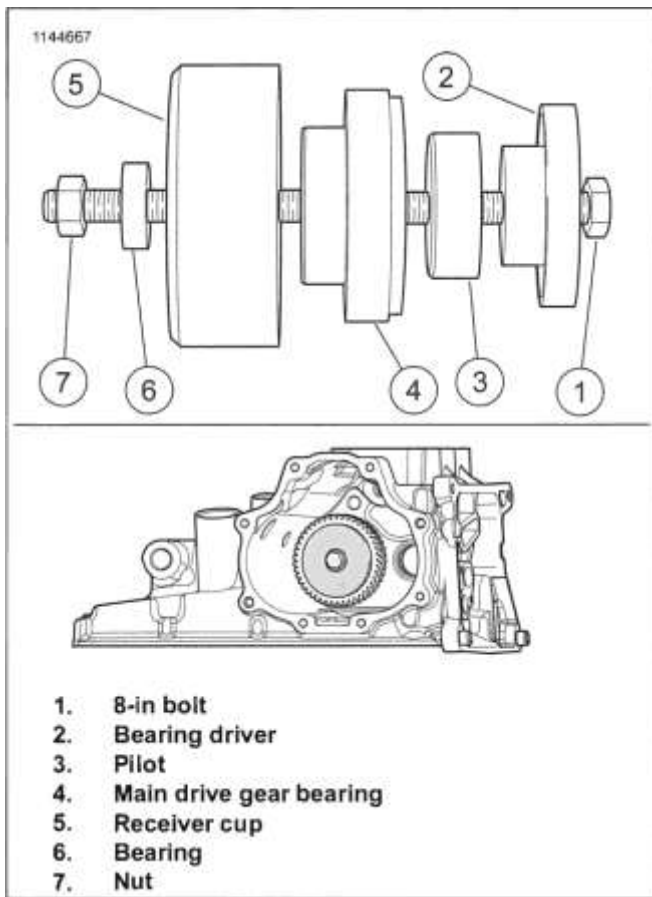


Figure 5-64. Removing Main Drive Gear Bearing

### CLEAN AND INSPECT

#### NOTE

Never wash transmission case and needle bearings with solvent unless replacing needle bearings. Normal cleaning methods wash dirt or other contaminants into bearing case (behind the needles) and leads to bearing failure.

1. Clean all parts in solvent except transmission case and needle bearings. Dry parts with low-pressure, compressed air.
2. See Figure 5-69. Inspect main drive gear (3) for pitting and wear.
3. Inspect needle bearings (2) inside main drive gear.
4. Inspect mainshaft race. Replace needle bearings if mainshaft race is damaged.

### INSTALL

| PART NUMBER | TOOLNAME                                  |
|-------------|---|
| HD-35316-D  | MAIN DRIVE GEAR REMOVER AND INSTALLER SET |
| HD-47856    | MAIN DRIVE GEAR SEAL INSTALLER KIT        |

#### NOTICE

Improper tightening of sprocket nut can cause drive component damage. (00541b)

1. See Figure 5-63 and Figure 5-65. Install main drive gear bearing.

Special Tool: MAIN DRIVE GEAR REMOVER AND INSTALLER SET (HD-35316-D)

2. See Figure 5-66. Install **new** O-ring (4) onto main drive gear (3). Lubricate O-ring with clean engine oil.

3. Install main drive gear.

Special Tool: MAIN DRIVE GEAR REMOVER AND INSTALLER SET (HD-35316-D)

4. Install **new** retaining ring.

#### NOTE

See Figure 5-67. Install retaining ring with flat side facing bearing and opening within range shown.

5. See Figure 5-68. Install **new** main drive gear large seal.

Special Tool: MAIN DRIVE GEAR SEAL INSTALLER KIT (HD-47856)

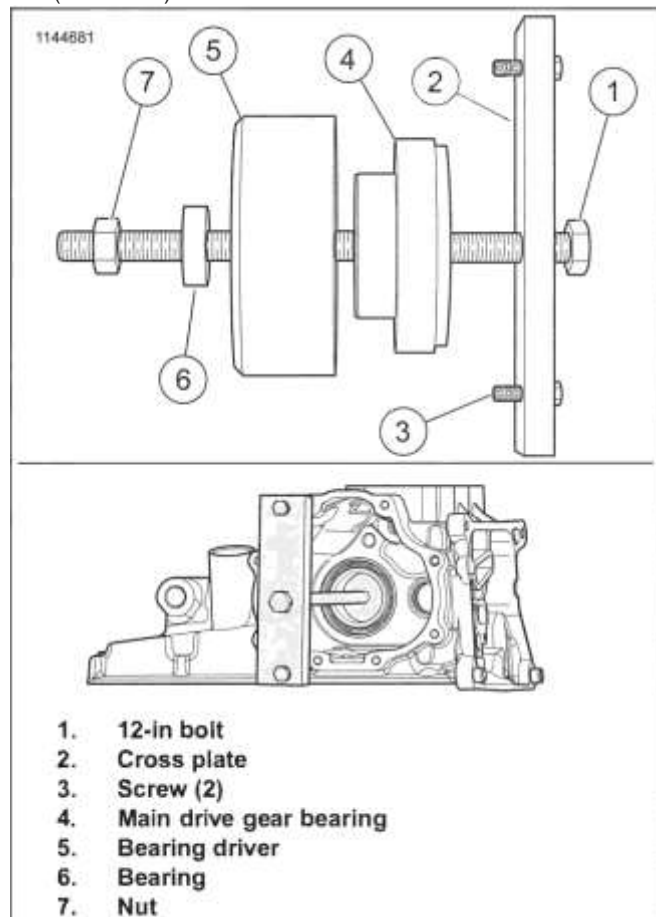
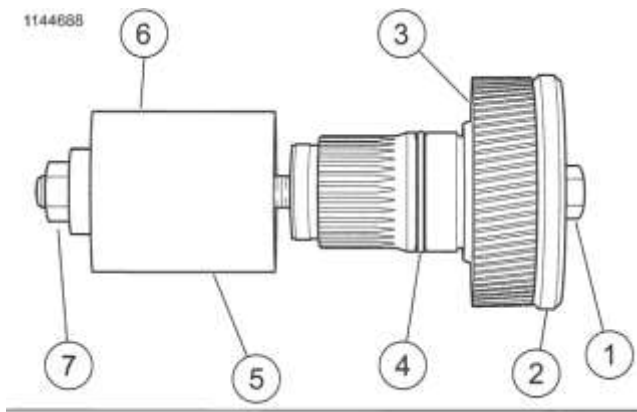


Figure 5-65. Installing Main Drive Gear Bearing (Typical)





1. 8-in bolt
2. Washer
3. Main drive gear
4. O-ring
5. Installer cup
6. Bearing
7. Nut

Figure 5-66. Installing Main Drive Gear (Typical)

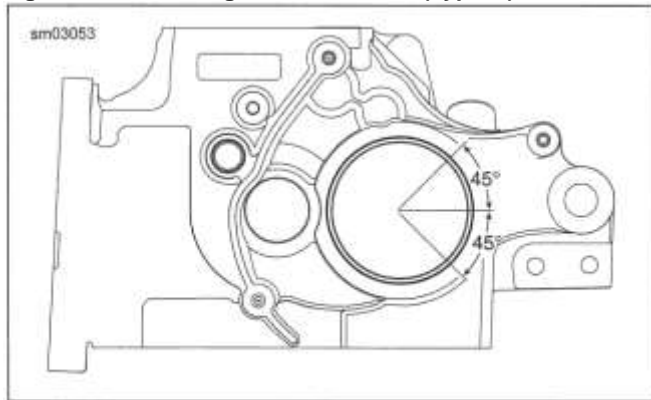
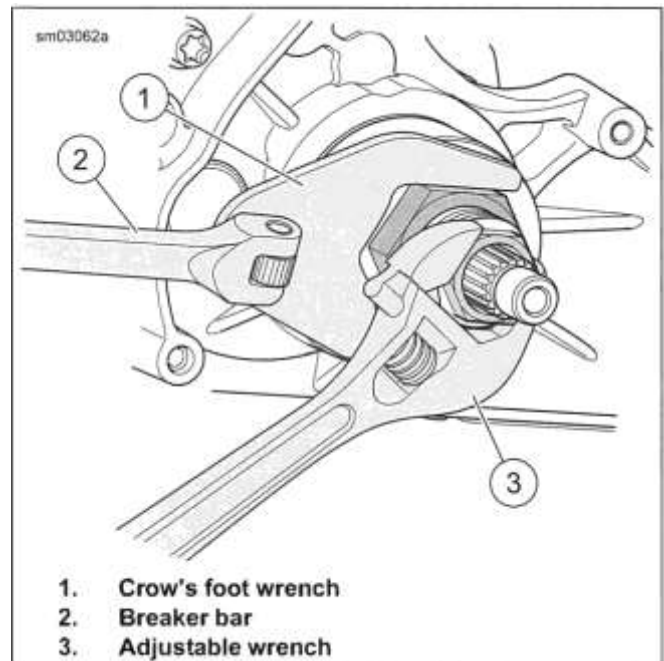


Figure 5-67. Retaining Ring Opening



1. Crow's foot wrench
2. Breaker bar
3. Adjustable wrench

Figure 5-68. Press Seal into Crankcase

### REPLACE NEEDLE BEARINGS

| PART NUMBER | TOOL NAME  |
|-------------|--|
| HD-47932    | MAIN DRIVE GEAR BEARING AND SEAL INSTALLATION TOOL |

#### Remove

1. See Figure 5-69. Remove and discard mainshaft seal (6).
2. Remove retaining rings (1), needle bearings (2) and spacer (5) from main drive gear (3). Discard retaining rings.
3. Discard O-ring (4).

#### Install

1. See Figure 5-71. Press in outer needle bearing near spline end of main drive gear until tool contacts spline.  
  
Special Tool: MAIN DRIVE GEAR BEARING AND SEAL INSTALLATION TOOL (HD-47932)
2. See Figure 5-72. Install mainshaft seal with garter spring side down.

#### NOTE

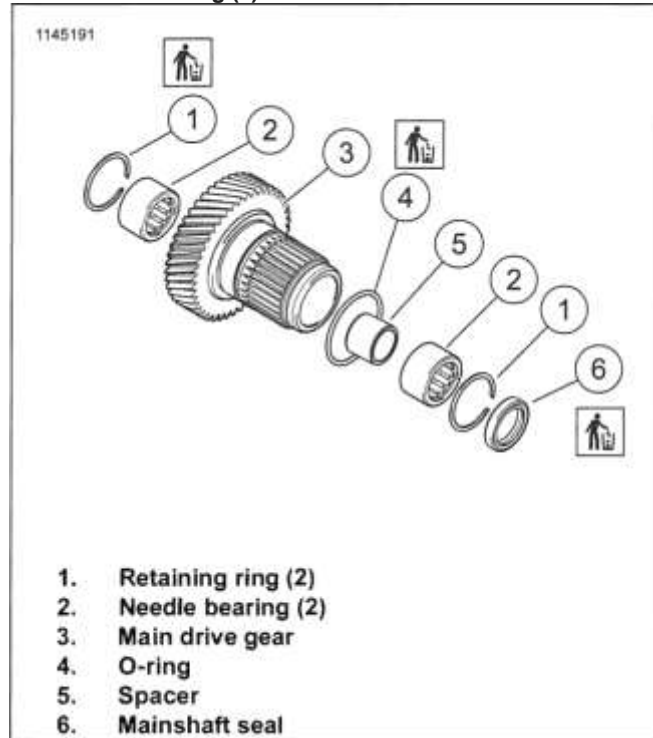
Mainshaft seal can also be installed after main drive gear is installed. See Replace Mainshaft Seal (Page 5-45).

- a. Use the 0.090-in step of main drive gear bearing and seal tool.  
  
Special Tool: MAIN DRIVE GEAR BEARING AND SEAL INSTALLATION TOOL (HD-47932)
  - b. Press until tool contacts gear.
3. See Figure 5-69. Turn over the main drive gear. Install spacer (5).
  4. See Figure 5-73. Press inner needle bearing from gear end until tool contacts gear.

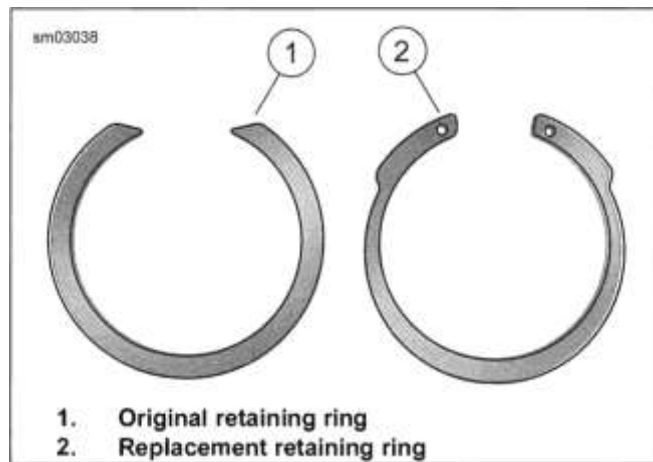
**Special Tool: MAIN DRIVE GEAR BEARING AND SEAL INSTALLATION TOOL (HD-47932)**

5. See Figure 5-69. Install new retaining rings (1).

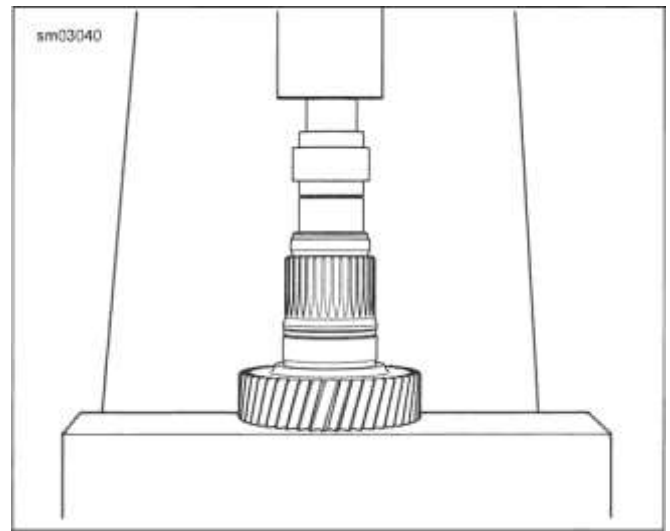
6. Install new O-ring (4).



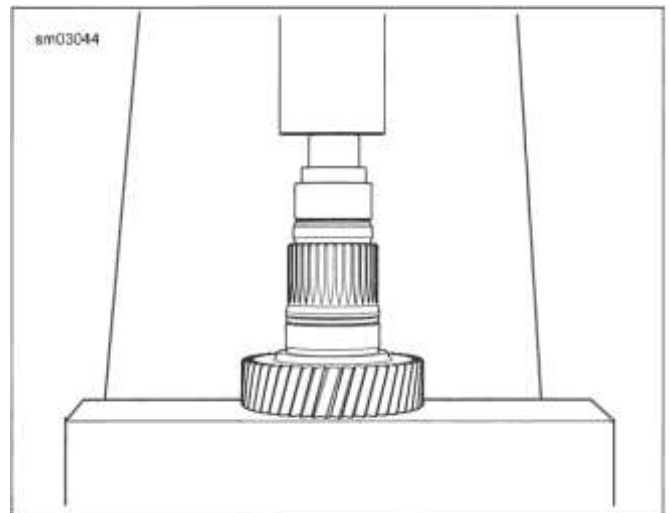
**Figure 5-69. Main Drive Gear Assembly**



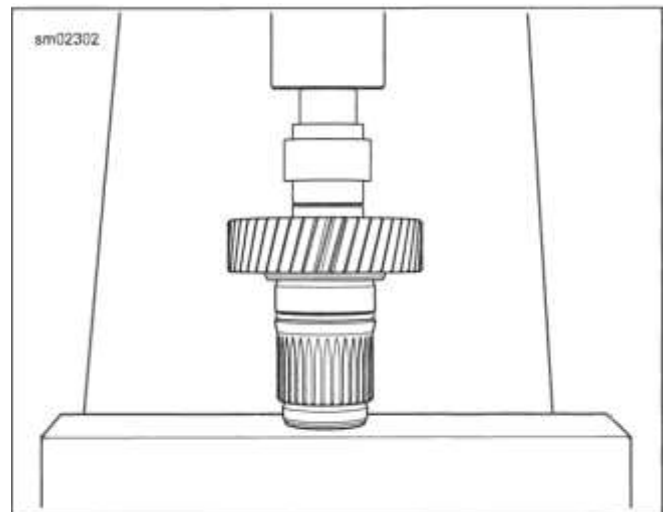
**Figure 5-70. Main Drive Gear Retaining Rings**



**Figure 5-71. Installing Outer Needle Bearing in Main Drive Gear**



**Figure 5-72. Pressing in Seal**



**Figure 5-73. Installing Inner Needle Bearing in Main Drive Gear**

**REPLACE.MAINSHAFTSEAL**

|                    |                                |
|--------------------|--------------------------------|
| <b>PART NUMBER</b> | <b>TOOL NAME</b>               |
| HD-47933           | MAIN DRIVE GEAR SEAL INSTALLER |

## Remove

See Figure 5-63. Replace mainshaft seal while main drive gear is installed.

1. Remove mainshaft seal (4).
2. Verify that bore is clean and smooth.

## Install

1. See Figure 5-75 Place seal protector sleeve (1) from gear seal installer over end of mainshaft.

Special Tool: MAIN DRIVE GEAR SEAL INSTALLER (HD-47933)

2. Lightly lubricate protector sleeve and seal ID with clean transmission oil.
3. Slide seal (2) on seal protector sleeve with garter spring facing bearing.
4. See Figure 5-76. Hand press seal onto place until seal driver contacts end of main drive gear. Lightly tap with a rubber mallet if necessary.

Special Tool: MAIN DRIVE GEAR SEAL INSTALLER (HD-47933)

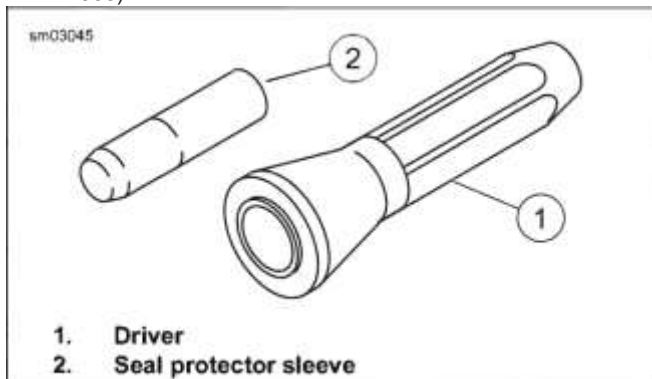


Figure 5-74. Main Drive Gear Seal Installer

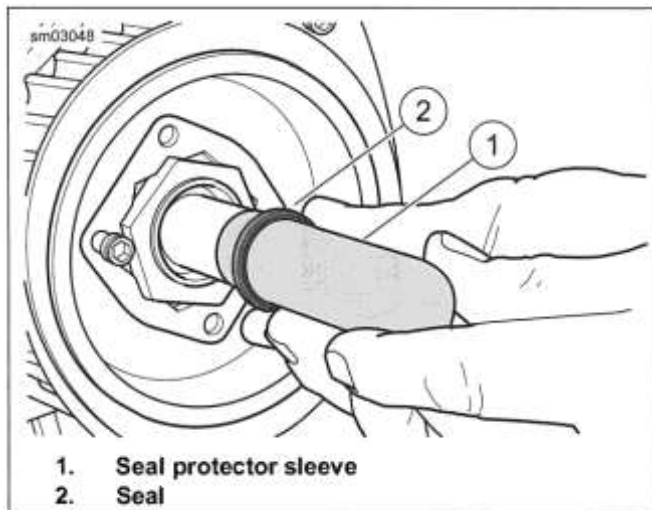


Figure 5-75. Seal Protector Sleeve

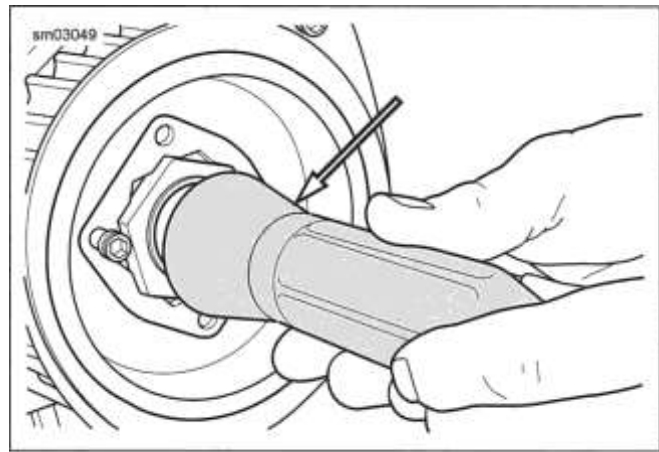


Figure 5-76. Seal Driver

## COMPLETE

1. Install bearing housing and gear assembly. See TRANSMISSION (Page 5-32).
2. Install transmission sprocket. See TRANSMISSION SPROCKET (Page 5-29).
3. Install bearing inner race to transmission mainshaft. See Mainshaft Bearing Inner Race (Page 5-27).
4. Install primary chaincase housing. See PRIMARY CHAINCASE HOUSING (Page 5-25).
5. Install the primary chain, clutch, compensating sprocket and chain tensioner. See DRIVE COMPONENTS (Page 5-16).
6. Install starter. See STARTER (Page 8-11).
7. Install primary chaincase cover and new gasket. See PRIMARY CHAINCASE COVER (Page 5-14).
8. Fill primary chaincase oil. See REPLACE PRIMARY CHAINCASE LUBRICANT (Page 2-11).
9. Install heel shift lever. See SHIFTER LINKAGE (Page 5-7).
10. Install rider left footboard and bracket, if removed. See RIDER FOOTRESTS (Page 3-142).
11. Adjust drive belt deflection. See INSPECT AND ADJUST DRIVE BELT AND SPROCKETS (Page 2-37).
12. Verify rear fork pivot shaft torque. See REAR FORK (Page 3-75).
13. Connect negative battery cable. See POWER DISCONNECT (Page 8-8).

## PREPARE

### A WARNING

Disconnect negative (■) battery cable first. If positive (+) cable should contact ground with negative (■) cable connected, the resulting sparks can cause a battery explosion, which could result in death or serious injury. (00049a)

1. Disconnect negative battery cable. See POWER DISCONNECT (Page 8-8).
2. Drain engine oil. See REPLACE ENGINE OIL AND FILTER (Page 2-9).
3. Drain transmission oil. See REPLACE TRANSMISSION LUBRICANT (Page 2-13).
4. Drain primary chaincase oil. See REPLACE PRIMARY CHAINCASE LUBRICANT (Page 2-11).
5. See Figure 5-79. Disconnect oil return line from oil return tube (1).
6. Remove exhaust system. See EXHAUST SYSTEM (Page 6-34).
7. Remove clutch release cover. See CLUTCH RELEASE COVER (Page 5-9).
8. Remove rider footboard and bracket, if needed. See RIDER FOOTRESTS (Page 3-142).
9. Remove shift levers and shift lever shaft. See SHIFTER LINKAGE (Page 5-7).
10. Remove primary chaincase cover. See PRIMARY CHAINCASE COVER (Page 5-14).
11. Remove starter. See STARTER (Page 8-11).
12. Remove primary chain, clutch and compensating sprocket. See DRIVE COMPONENTS (Page 5-16).
13. Remove primary chaincase housing. See PRIMARY CHAINCASE HOUSING (Page 5-25).
14. Loosen drive belt. See INSPECT AND ADJUST DRIVE BELT AND SPROCKETS (Page 2-37).
15. Remove transmission assembly. See TRANSMISSION (Page 5-32).
16. Remove oil pan. See OIL PAN (Page 4-75).

## NOTICE

When lifting a motorcycle using a jack, be sure jack contacts both lower frame tubes where down tubes and lower frame tubes converge. Never lift by jacking on cross-members, oil pan, mounting brackets, components or housings. Failure to comply can cause serious damage resulting in the need to perform major repair work. (00586d)

17. Position jack across lower frame to support rear of motorcycle. Slide wooden blocks beneath crankcase to support weight of engine and transmission assembly.
18. Remove rear fork. See REAR FORK (Page 3-75).
19. Disconnect neutral switch. See NEUTRAL INDICATOR SWITCH (Page 8-37).

## REMOVE

1. Remove battery negative cable from ground post at top of transmission case.
2. Move aside harness that terminates at O2 sensor, starter solenoid and neutral switch.
3. In a cross-wise pattern, remove four bolts securing transmission to engine.

### NOTE

See Figure 5-77. Do not use a hammer to remove transmission. If transmission sticks or binds on ring dowels, gently pry away from crankcase using pry point.

4. Move transmission rearward until two ring dowels in lower flange are free of crankcase.
5. Remove transmission case from left side of motorcycle.

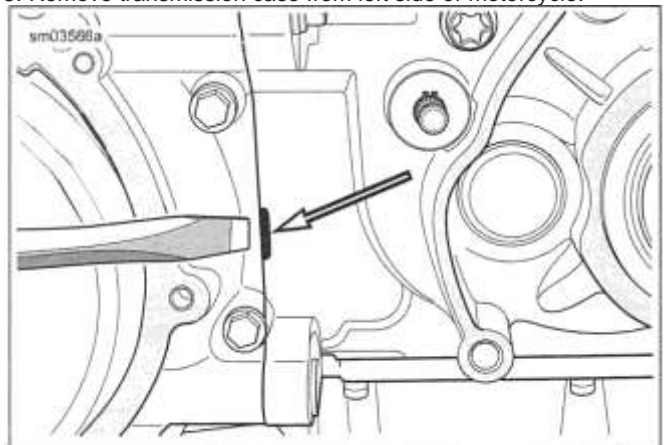


Figure 5-77. Transmission Case Pry Point

## INSTALL

| FASTENER                                  | TORQUE VALUE  |               |
|---|---------------|---------------|
| Battery ground cable to transmission      | 66-114 in-lbs | 7.5-12.9 N-m  |
| Transmission mounting bolts, 1st torque   | 15 ft-lbs     | 20.3 N-m      |
| Transmission mounting bolts, final torque | 34-39 ft-lbs  | 46.1-52.9 N-m |

1. Install new ground post at top of transmission case. Tighten ground post until snug.

**NOTE**

A new transmission case has shifter shaft sleeve and seal, centering screw, countershaft needle bearing and main drive gear bearing and seal installed.

2. Wipe all engine oil from pockets in crankcase flange.
3. Install new engine-to-transmission gasket.
4. Verify that transmission dowels are seated. Place transmission case into position.
5. Secure transmission.
  - a. Install shorter bolts at top, longer bolts at bottom. Hand-tighten bolts.
  - b. See Figure 5-78. Tighten bolts in sequence.  
Torque: 15 ft-lbs (20.3 N-m) *Transmission mounting bolts, 1st torque*
  - c. Tighten to final torque in same sequence.  
Torque: 34-39 ft-lbs (46.1-52.9 N-m) *Transmission mounting bolts, final torque*
6. Secure battery ground cable to ground post at top of transmission case. Tighten.  
Torque: 66-114 in-lbs (7.5-12.9 N-m) *Battery ground cable to transmission*

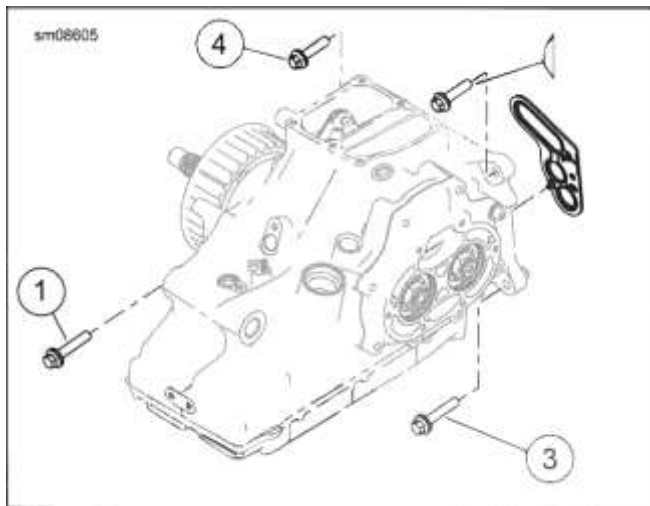


Figure 5-78. Transmission Housing to Crankcase Tightening Sequence

**DISASSEMBLE**

**Remove Shifter Pawl Lever**

1. See Figure 5-81. Remove shifter rod lever.
  - a. Mark splines on shifter pawl lever assembly (1) and shift rod lever (9) to help with assembly.
  - b. Remove screw (8).
  - c. Remove shifter rod lever from shifter pawl lever assembly.

2. Remove shifter pawl assembly.
  - a. Remove retaining ring (7), washer (6) and seal (5).
  - b. Discard retaining ring and seal.
  - c. Remove shifter pawl lever assembly (1).
3. Inspect sleeve (3) in transmission case.

**Remove Oil Return Tube/Cover**

1. See Figure 5-79. Remove oil return tube or cover.
  - a. If transmission case is installed in vehicle disconnect battery.
  - b. Remove screw (1).
  - c. Remove oil return tube (2) or cover (3).

**CLEAN AND INSPECT**

**A WARNING**

Compressed air can pierce the skin and flying debris from compressed air could cause serious eye injury. Wear safety glasses when working with compressed air. Never use your hand to check for air leaks or to determine air flow rates. (00061 a)

**NOTE**

Never wash transmission case and needle bearings with solvent. Normal cleaning methods wash dirt or other contaminants into bearing case (behind the needles) leading to bearing failure.

1. Clean all parts in solvent except case and main drive gear needle bearings. Dry parts with low-pressure, compressed air.
2. See Figure 5-81. Inspect shifter pawl lever assembly (1) for wear. Replace assembly if pawl ends are damaged. Replace centering spring (2) if elongated.
3. Inspect shifter shaft lever spring (4). Replace if spring fails to hold pawl on cam pins.
4. Thoroughly clean oil pan.
5. Inspect transmission top cover vent hose for damage. Verify that hose and fitting are unobstructed.

**ASSEMBLE**

| PART NUMBER | TOOL NAME                            |
|-------------|--------------------------------------|
| HD-51337    | SHIFTER SHAFT SEAL INSTALLATION TOOL |

| FASTENER                      | TORQUE VALUE   |               |
|-------------------------------|----------------|---------------|
| Oil return tube screw         | 100—120 in-lbs | 11.3-13.6 N-m |
| Shifter pawl centering screw  | 18-23 ft-lbs   | 24.4-31.2 N-m |
| Shifter rod lever pinch screw | 18-22 ft-lbs   | 24.4-29.8 N-m |

## Install Oil Return Tube/Cover

- See Figure 5-79. Install oil return tube or cover.
  - Install **new** O-ring (4).
  - Install oil return tube (2) or cover (3).
  - Install screw (1). Tighten.  
Torque: 100-120 **in-lbs** (11.3-13.6 N-m) *Oil return tube screw*

## Replace Countershaft Needle Bearing

- See Figure 5-80. Remove countershaft bearing.
- Install **new** bearing.
  - From outside of transmission case, place bearing on bearing bore.
  - Install bearing flush or to a maximum depth of 0.030 in (0.76 mm) with outside surface of case.
- Lubricate bearing with SCREAMIN' EAGLE ASSEMBLY LUBE.

## Install Shifter Pawl Lever

- See Figure 5-81. Verify that sleeve (3) is in transmission case bore.
- Install screw (10) into side of transmission case. Tighten.  
Torque: 18-23 ft-lbs (24.4-31.2 N-m) *Shifter pawl centering screw*
- See Figure 5-82. Assemble shifter arm.
  - Slide centering spring (3) over shaft of shifter pawl lever (2).
  - Align opening on spring with tab on lever.
  - Place lever spring (4) on shifter pawl lever. Flex spring only enough to assemble.
- See Figure 5-83. Insert shifter arm assembly into transmission case.
- See Figure 5-84. Verify that pin of screw sits inside lever spring.
- Install **new** seal with garter spring facing transmission. Drive seal until tool bottoms on transmission case.  
Special Tool: SHIFTER SHAFT SEAL INSTALLATION TOOL (HD-51337)
- See Figure 5-83. Install washer (1) and **new** retaining ring (2).

### NOTE

*Install shifter rod lever one spline from vertical toward front of vehicle.*

- See Figure 5-81. Install shifter rod lever (9).
  - Install pinch screw (8).

- Tighten.

Torque: 18-22 ft-lbs (24.4-29.8 N-m) *Shifter rod lever pinch screw*

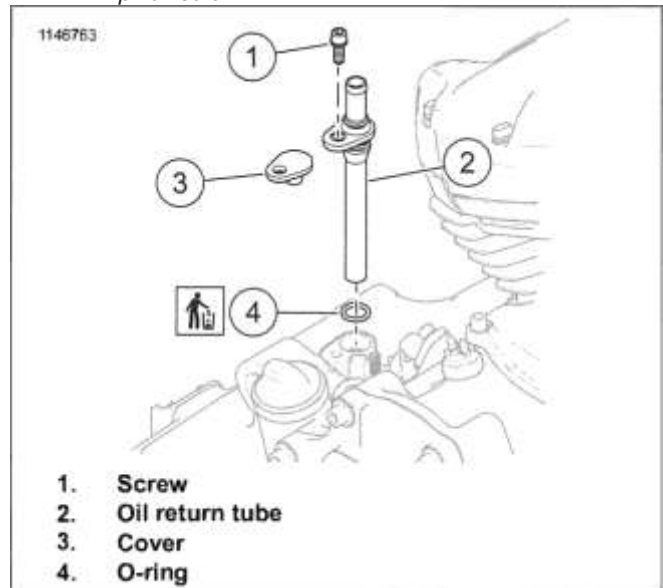


Figure 5-79. Oil Return Tube/Cover

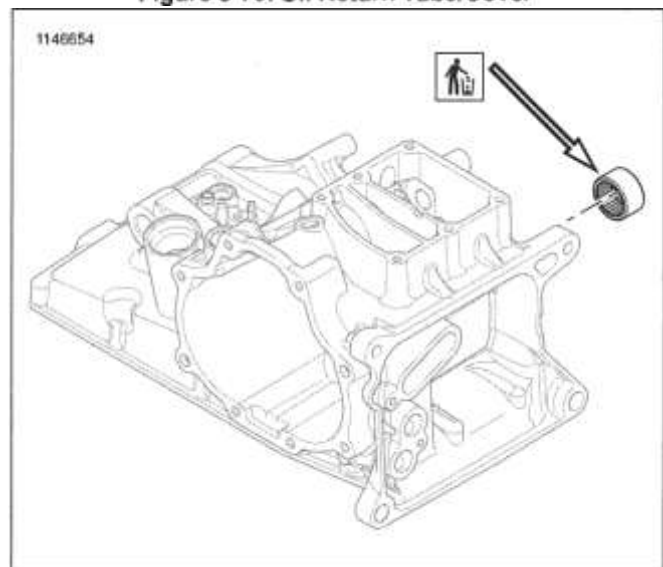
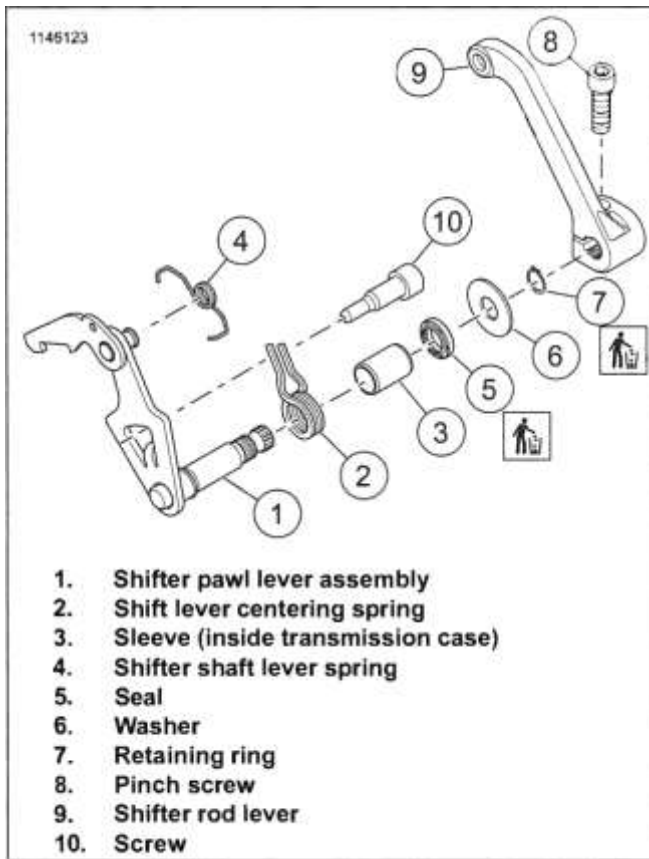
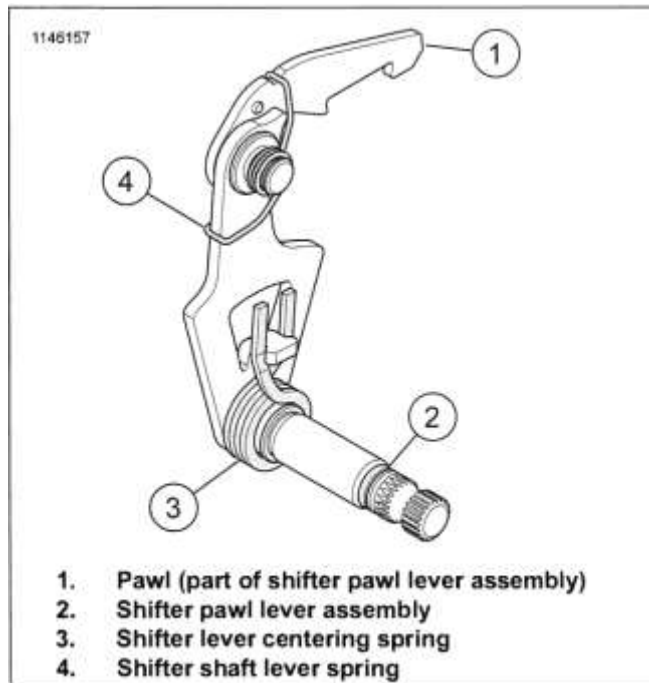


Figure 5-80. Countershaft Needle Bearing



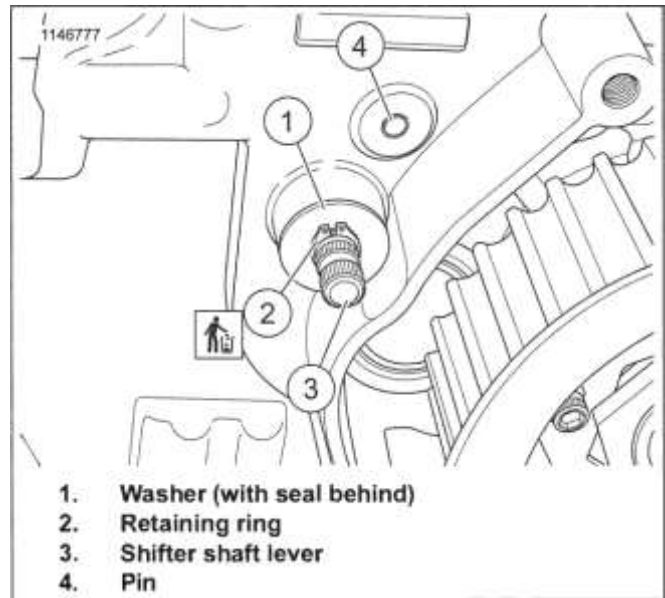
1. Shifter pawl lever assembly
2. Shift lever centering spring
3. Sleeve (inside transmission case)
4. Shifter shaft lever spring
5. Seal
6. Washer
7. Retaining ring
8. Pinch screw
9. Shifter rod lever
10. Screw

Figure 5-81. Shifter Arm and Pawl Assembly (Typical)



1. Pawl (part of shifter pawl lever assembly)
2. Shifter pawl lever assembly
3. Shifter lever centering spring
4. Shifter shaft lever spring

Figure 5-82. Shifter Pawl Lever Assembly



1. Washer (with seal behind)
2. Retaining ring
3. Shifter shaft lever
4. Pin

Figure 5-83. Shifter Shaft Lever, Exterior View

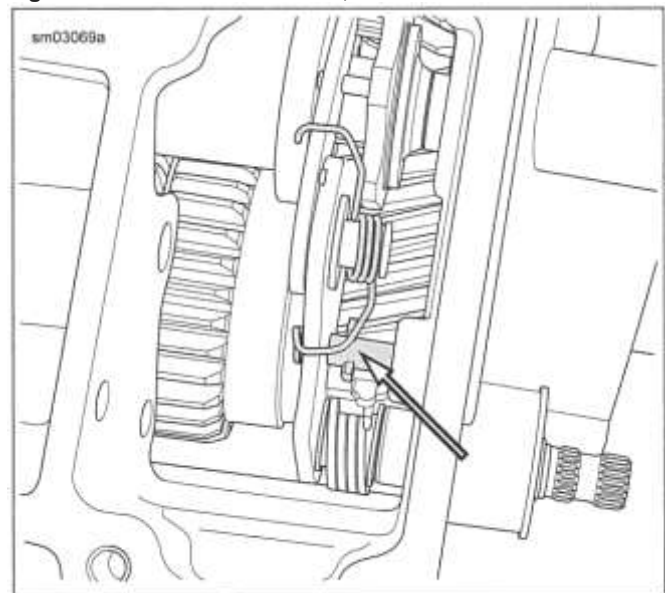


Figure 5-84. Shifter Shaft Lever Spring

1. Install neutral switch. See NEUTRAL INDICATOR SWITCH (Page 8-37).
2. Install rear fork. See REAR FORK (Page 3-75).
3. Install oil pan. See OIL PAN (Page 4-75).
4. Install transmission. See TRANSMISSION (Page 5-32).
5. Install primary chaincase housing. See PRIMARY CHAINCASE HOUSING (Page 5-25).
6. Install primary chain, clutch and compensating sprocket. See DRIVE COMPONENTS (Page 5-16).
7. See Figure 5-79. Connect oil return line to oil return tube (1).
8. Install starter. See STARTER (Page 8-11).

**COMPLETE**

9. Install primary chaincase cover and **new** gasket. See PRIMARY CHAINCASE COVER (Page 5-14).
10. Install foot shift levers. See SHIFTER LINKAGE (Page 5-7).
11. Install rider footboard and bracket, if removed. See RIDER FOOTRESTS (Page 3-142).
12. Install transmission shift linkage. See SHIFTER LINKAGE (Page 5-7).
13. Install clutch release cover. See CLUTCH RELEASE COVER (Page 5-9).
14. Install exhaust system. See EXHAUST SYSTEM (Page 6-34).
15. Fill primary chaincase. See REPLACE PRIMARY CHAINCASE LUBRICANT (Page 2-11).
16. Fill transmission. See REPLACE TRANSMISSION LUBRICANT (Page 2-13).
17. Fill engine oil. See REPLACE ENGINE OIL AND FILTER (Page 2-9).
18. Adjust drive belt deflection. See INSPECT AND ADJUST DRIVE BELT AND SPROCKETS (Page 2-37).
19. Connect negative battery cable. See POWER DISCONNECT (Page 8-8).



## NOTES

| <b>SUBJECT</b>  | <b>PAGE NO.</b> |
|---|-----------------|
| 6.1 FASTENER TORQUE VALUES .....                                | 6-1             |
| 6.2 SPECIFICATIONS .....  | 6-2             |
| 6.3 AIR CLEANER BACKPLATE ASSEMBLY .....                        | 6-3             |
| 6.4 CONSOLE.....  | 6-5             |
| 6.5 FUEL PRESSURE TEST .....                                    | <b>6-6</b>      |
| 6.6 PURGE FUEL LINE .....                                       | 6-7             |
| 6.7 FUEL LINE.....  | <b>6-8</b>      |
| 6.8 FUEL TANK .....   | 6-10            |
| 6.9 FUEL TANK TOP PLATE .....                                   | 6-11            |
| 6.10 FUEL LEVEL SENDER.....                                     | 6-15            |
| 6.11 FUEL PUMP.....   | 6-16            |
| 6.12 VENT TUBE .....  | 6-19            |
| 6.13 VAPOR VALVE .....  | 6-20            |
| 6.14 TEMPERATURE MANIFOLD ABSOLUTE PRESSURE (TMAP) SENSOR ..... | 6-21            |
| 6.15 TWIST GRIP SENSOR (TGS).....                               | 6-22            |
| 6.16 FUEL INJECTORS.....  | 6-25            |
| 6.17 INDUCTION MODULE .....                                     | 6-26            |
| 6.18 INTAKE LEAK TEST .....                                     | 6-30            |
| 6.19 HEATED OXYGEN SENSORS (HO2S).....                          | 6-31            |
| 6.20 MUFFLERS.....  | 6-33            |
| 6.21 EXHAUST SYSTEM .....                                       | 6-34            |
| 6.22 PURGE SOLENOID: EVAPORATIVE EMISSIONS .....                | 6-37            |
| 6.23 CHARCOAL CANISTER: EVAPORATIVE EMISSIONS .....             | 6-38            |
| 6.24 PURGE LINES: EVAPORATIVE EMISSIONS .....                   | 6-39            |

## NOTES



## FASTENER TORQUE VALUES IN THIS CHAPTER

| FASTENER  | TORQUE VALUE   |               | NOTES  |
|---|----------------|---------------|--|
| Air cleaner backplate screws, oval                  | 55-60 in-lbs   | 6.2-6.8 N-m   | 6.3 AIR CLEANER BACKPLATE ASSEMBLY, Install  |
| Air cleaner breather bolts, oval                    | 22-24 ft-lbs   | 29.8-32.5 N-m | 6.3 AIR CLEANER BACKPLATE ASSEMBLY, Install  |
| Air cleaner breather bolts, standard                | 22-24 ft-lbs   | 29.8-32.5 N-m | 6.3 AIR CLEANER BACKPLATE ASSEMBLY, Install  |
| Air filter element screws, standard                 | 40-60 in-lbs   | 4.5-6.8 N-m   | 6.3 AIR CLEANER BACKPLATE ASSEMBLY, Install  |
| Charcoal canister                                   | 15-20 in-lbs   | 1.7-2.3 N-m   | 6.23 CHARCOAL CANISTER: EVAPORATIVE EMISSIONS, Install                             |
| Console screw (Front)                               | 20-30 in-lbs   | 2.3-3.4 N-m   | 6.4 CONSOLE, Install   |
| Console screw (Rear)                                | 40-60 in-lbs   | 4.1-6.8 N-m   | 6.4 CONSOLE, Install   |
| Exhaust bracket to transmission, screw              | 100-120 in-lbs | 11.3-13.6 N-m | 6.21 EXHAUST SYSTEM, Install   |
| Exhaust cross-over bracket flange bolt              | 14-18 ft-lbs   | 19-24.4 N-m   | 6.21 EXHAUST SYSTEM, Install   |
| Exhaust cross-over pipe clamp                       | 38-43 ft-lbs   | 51.5-58.3 N-m | 6.21 EXHAUST SYSTEM, Install   |
| Exhaust flange nut, 1st torque                      | 9-18 in-lbs    | 1-2 N-m       | 6.21 EXHAUST SYSTEM, Install<br>See procedure for appropriate tightening sequence. |
| Exhaust flange nut, final torque                    | 100-120 in-lbs | 11.3-13.6 N-m | 6.21 EXHAUST SYSTEM, Install<br>See procedure for appropriate tightening sequence. |
| Exhaust flange nut, final torque                    | 100-120 in-lbs | 11.3-13.6 N-m | 6.21 EXHAUST SYSTEM, Install<br>See procedure for appropriate tightening sequence. |
| Exhaust header bracket flange locknut               | 15-20 ft-lbs   | 20.3-27.1 N-m | 6.21 EXHAUST SYSTEM, Install   |
| Exhaust shield clamps                               | 20-40 in-lbs   | 2.3-4.5 N-m   | 6.21 EXHAUST SYSTEM, Install   |
| Fuel rail screw                                     | 30-50 in-lbs   | 3.5-5.5 N-m   | 6.16 FUEL INJECTORS, Install   |
| Fuel tank front screws                              | 15-20 ft-lbs   | 20.3-27.1 N-m | 6.8 FUEL TANK, Install   |
| Fuel tank rear bracket screws                       | 15-20 ft-lbs   | 20.3-27.1 N-m | 6.8 FUEL TANK, Install   |
| Induction module flange adapter screws.             | 96-156 in-lbs  | 10.9-17.6 N-m | 6.17 INDUCTION MODULE, Install   |
| Induction module flange adapter screws.             | 96-156 in-lbs  | 10.9-17.6 N-m | 6.17 INDUCTION MODULE, Install   |
| Induction module screw                              | 66-84 in-lbs   | 7.5-9.5 N-m   | 6.17 INDUCTION MODULE, Assemble  |
| Muffler to clamp                                    | 38-43 ft-lbs   | 51.5-58.3 N-m | 6.20 MUFFLERS, Install   |
| Muffler to saddlebag support screws                 | 14-18 ft-lbs   | 19-24.4 N-m   | 6.20 MUFFLERS, Install   |
| Oxygen sensor, heated                               | 12-14 ft-lbs   | 16-19 N-m     | 6.19 HEATED OXYGEN SENSORS (HO2S), Install<br>add anti-seize lubricant (98960-97)  |
| Oxygen sensor, heated                               | 12-14 ft-lbs   | 16-19 N-m     | 6.19 HEATED OXYGEN SENSORS (HO2S), Install<br>add anti-seize lubricant (98960-97)  |
| Oxygen sensor, heated                               | 12-14 ft-lbs   | 16-19 N-m     | 6.19 HEATED OXYGEN SENSORS (HO2S), Install<br>add anti-seize lubricant (98960-97)  |
| Temperature manifold absolute pressure (TMAP) screw | 22-40 in-lbs   | 2.5-4.5 N-m   | 6.14 TEMPERATURE MANIFOLD ABSOLUTE PRESSURE (TMAP) SENSOR, Install                 |
| Throttle body to manifold screws                    | 35-53 in-lbs   | 4-6 N-m       | 6.17 INDUCTION MODULE, Assemble  |

# SPECIFICATIONS

## SPECIFICATIONS

Table 6-1. Fuel Capacity

| FUEL TANK CAPACITY         | GALLONS | LITERS |
|----------------------------|---------|--------|
| Total                      | 6.0     | 22.7   |
| Reserve (warning light on) | 1.0     | 3.79   |

## PREPARE

1. **Oval:** Remove air cleaner insert. See INSPECT AIR FILTER (Page 2-46).
2. Remove air cleaner cover and filter. See INSPECT AIR FILTER (Page 2-46).

## REMOVE

### Standard

1. See Figure 6-1. Remove breather tube assembly (1).
2. Remove backplate.
  - a. Remove breather bolts (2).
  - b. Remove backplate (3).
3. Discard seal ring (4).

### Oval

1. See Figure 6-2. Remove breather tubes (2).
2. Remove air cleaner backplate.
  - a. Remove breather bolts (3).
  - b. Remove screws (1).
  - c. Remove backplate (4).
3. Discard gasket (5).

## INSTALL

| FASTENER                             | TORQUE VALUE |               |
|--------------------------------------|--------------|---------------|
| Air cleaner backplate screws, oval   | 55-60 in-lbs | 6.2-6.8 N-m   |
| Air cleaner breather bolts, standard | 22-24 ft-lbs | 29.8-32.5 N-m |
| Air cleaner breather bolts, oval     | 22-24 ft-lbs | 29.8-32.5 N-m |
| Air filter element screws, standard  | 40-60 in-lbs | 4.5-6.8 N-m   |

- c. Install screws (3). Tighten.

| PART NUMBER | CONSUMABLE                 |
|-------------|----------------------------|
| 199818-97   | LOCTITE 565 THREAD SEALANT |

### Standard

1. See Figure 6-1. Install new seal ring (4) on backplate (3).
2. Install backplate. Install filter element.
  - a. Install breather tube (5).
  - b. Install filter element (4) while pushing breather tube into element.

**Torque: 40-60 in-lbs (4.5-6.8 N-m)** Air filter element screws, standard

3. Apply sealant to threads of breather bolts (2).

**Consumable: LOCTITE 565 THREAD SEALANT (99818-97)**

4. Install backplate with breather bolts. Tighten.

**Torque: 22-24 ft-lbs (29.8-32.5 N-m)** Air cleaner breather bolts, standard

### NOTE

Failure to connect the breather tubes allows crankcase vapors to be vented into the atmosphere in violation of legal emissions standards.

5. Install breather tubes (1) onto breather bolts.

### Oval

1. See Figure 6-2. Position new gasket (5) on backplate (4).

2. Install backplate but do not tighten screws (1).

3. Apply threadlocker to breather bolts (3).

**Consumable: LOCTITE 565 THREAD SEALANT (99818-97)**

4. Install breather bolts.

5. Tighten screws (1).

**Torque: 55-60 in-lbs (6.2-6.8 N-m)** Air cleaner backplate screws, oval

6. Tighten breather bolts.

**Torque: 22-24 ft-lbs (29.8-32.5 N-m)** Air cleaner breather bolts, oval

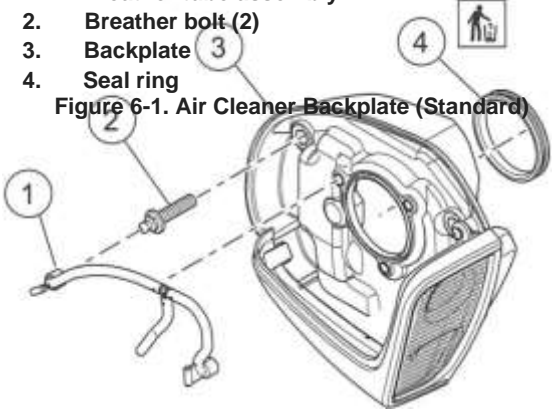
### NOTE

Failure to connect the breather tubes allows crankcase vapors to be vented into the atmosphere in violation of legal emissions standards.

7. Install breather tubes (2). Secure to retainer tabs (6) on backplate.

- 1. Breather tube assembly
- 2. Breather bolt (2)
- 3. Backplate
- 4. Seal ring

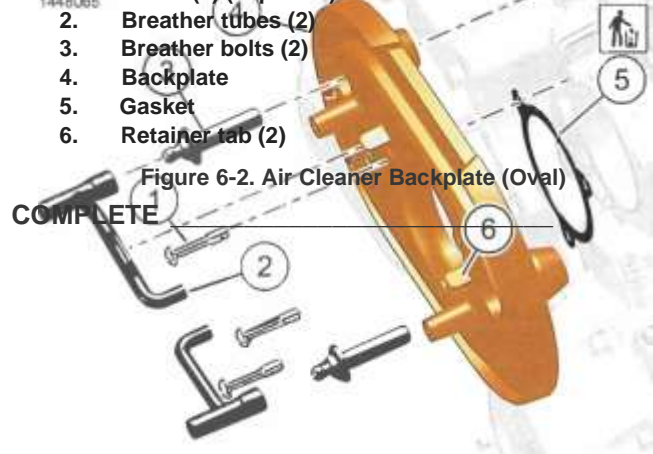
Figure 6-1. Air Cleaner Backplate (Standard)



- 1. Screw (3) (captured)
- 2. Breather tubes (2)
- 3. Breather bolts (2)
- 4. Backplate
- 5. Gasket
- 6. Retainer tab (2)

Figure 6-2. Air Cleaner Backplate (Oval)

COMPLETE



- 1. Install air cleaner cover and filter. See INSPECT AIR FILTER (Page 2-46).
- 2. **Oval:** Install air cleaner insert. See INSPECT AIR FILTER (Page 2-46).



**PREPARE**

1. Remove seat. See SEAT (Page 3-148).
2. Remove left saddlebag. See SADDLEBAGS (Page 3-161).
3. Remove left side cover. See LEFT SIDE COVER (Page 3-62).
4. Remove main fuse. See POWER DISCONNECT (Page 8-8).

**REMOVE**

1. See Figure 6-3. Disconnect connectors.
  - a. FLHX, FLT Models: Disconnect fuel tank connector (4).
  - b. Except FLHX, FLT Models: Disconnect fuel tank/console connector (5), if equipped.
2. Remove console.
  - a. Remove screws.
  - b. Models with fairing: Remove filler cap.
  - c. Remove console.

**INSTALL**

| FASTENER              | TORQUE VALUE |             |
|-----------------------|--------------|-------------|
| Console screw (Front) | 20-30 in-lbs | 2.3-3.4 N-m |
| Console screw (Rear)  | 40-60 in-lbs | 4.1-6.8 N-m |

1. Position console.
  - a. Position console on fuel tank.
  - b. Models with fairing: Install filler cap.
2. Verify harnesses and vent tube are not pinched.
3. Install screws.
  - a. Install front screw. Tighten.  
Torque: 20-30 in-lbs (2.3-3.4 N-m) *Console screw (Front)*

- b. Install rear screw. Tighten.  
Torque: 40-60 in-lbs (4.1-6.8 N-m) *Console screw (Rear)*

4. See Figure 6-3. Connect electrical connectors.
  - a. Except FLHX, FLT: Connect fuel tank/console connector (5), if equipped.
  - b. FLHX, FLT: Connect fuel tank connector (4).

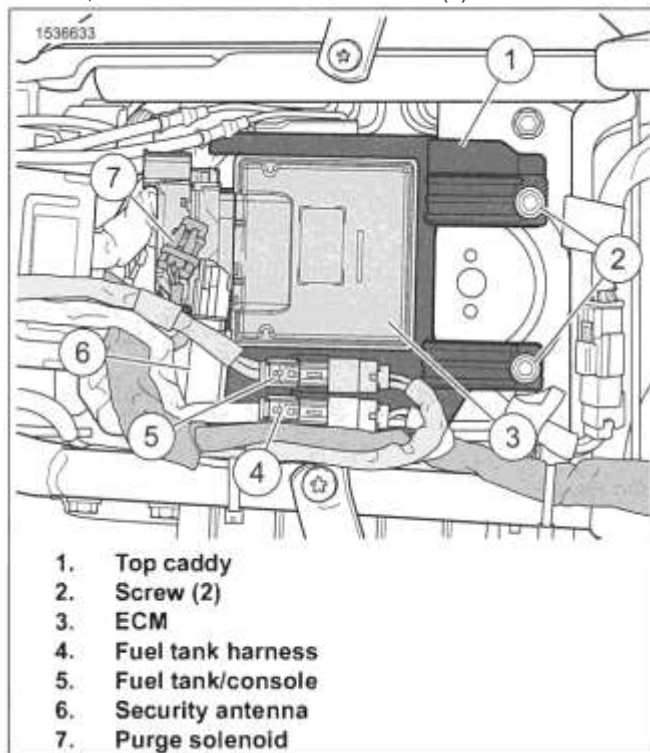


Figure 6-3. Top Caddy

**COMPLETE**

1. Install main fuse. See POWER DISCONNECT (Page 8-8).
2. Install left side cover. see LEFT SIDE COVER (Page 3-62).
3. Install left saddlebag. See SADDLEBAGS (Page 3-161).
4. Install seat. See SEAT (Page 3-148).

## PREPARE

**A WARNING**

Gasoline is extremely flammable and highly explosive. Keep gasoline away from ignition sources which could result in death or serious injury. See the Safety chapter. (00635c)

**A WARNING**

To prevent spray of fuel, purge system of high-pressure fuel before supply line is disconnected. Gasoline is extremely flammable and highly explosive, which could result in death or serious injury. (00275a)

1. Purge and disconnect fuel line. See FUEL TANK (Page 6-10).

## TEST

| PART NUMBER | TOOLNAME                    |
|-------------|-----------------------------|
| HD-41182    | FUEL PRESSURE GAUGE         |
| HD-44061    | FUEL PRESSURE GAUGE ADAPTER |

**NOTE**

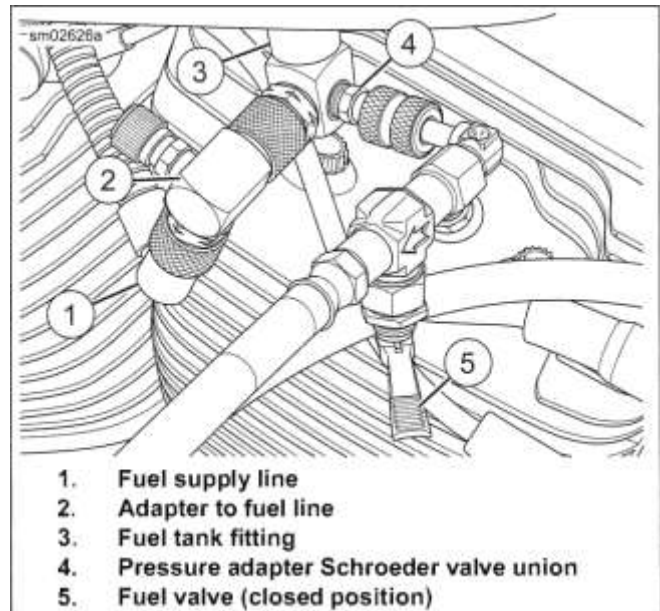
Use two fuel pressure gauge adapters to prevent twisting of the fuel supply line. Verify that all connections are secure.

1. See Figure 6-4 Attach to fuel tank fitting (3) and fuel supply line (1).  
Special Tool: FUEL PRESSURE GAUGE (HD-41182)  
Special Tool: FUEL PRESSURE GAUGE ADAPTER (HD-44061)
2. Close fuel valve (5).
3. Insert clear tube of fuel pressure gauge into a suitable container.
4. Start engine.
5. Open fuel valve.
6. Open clear tube bleeder valve.

7. Close clear tube bleeder valve.
8. Check pressure.
  - a. Operate engine at various speeds.
  - b. Note pressure gauge readings.
  - c. Compare readings to specifications. Refer to Table 6-2.
9. Turn off engine.
10. Open clear tube bleeder to remove pressure.
11. Remove fuel pressure tester.

**Table 6-2. Fuel Pressure**

| Specification | PSI   | kPa     |
|---------------|-------|---------|
| Fuel pressure | 55-62 | 380-425 |



**Figure 6-4. Fuel Pressure Test Connections**

## COMPLETE

1. Connect fuel supply line. See FUEL TANK (Page 6-10).

## PURGE

| PART NUMBER | TOOL NAME             |
|-------------|-----------------------|
| HD-48650    | DIGITAL TECHNICIAN II |

### **A WARNING**

To prevent spray of fuel, purge system of high-pressure fuel before supply line is disconnected. Gasoline is extremely flammable and highly explosive, which could result in death or serious injury. (00275a)

#### NOTE

The gasoline in the fuel supply line is under high pressure: 58 psi (400 kPa). To avoid an uncontrolled discharge or spray of gasoline, always purge the line before disconnecting.

1. Remove seat. See SEAT (Page 3-148).

#### NOTE

The preferred method to disable the fuel pump is to use a special tool. The fuel pump can optionally be disconnected instead. DIGITAL TECHNICIAN II (PART NUMBER: HD-48650)

2. Disconnect fuel pump.
  - a. **Models with fairing:** See Figure 6-5. Disconnect fuel pump connector [13] (gray) (4).
  - b. **Models without fairing:** Disconnect fuel pump connector (black) located under the console. See CONSOLE (Page 6-5).
3. Remove fuel from fuel supply line.
  - a. Run engine until it stalls.
  - b. Operate starter an additional 3 seconds.
4. Remove main fuse.
5. Connect fuel pump connector (gray).
6. See Figure 6-7. Remove fuel supply line.
  - a. Pull up on chrome sleeve of quick-connect fitting (1).
  - b. Pull down on fuel supply line (2) fitting to disconnect.

**PREPARE****A WARNING**

To prevent spray of fuel, purge system of high-pressure fuel before supply line is disconnected. Gasoline is extremely flammable and highly explosive, which could result in death or serious injury. (00275a)

1. Purge fuel line. See PURGE FUEL LINE (Page 6-7).
2. Remove main fuse. See POWER DISCONNECT (Page 8-8).
3. Remove left saddlebag. See SADDLEBAGS (Page 3-161).
4. Remove left side cover. See LEFT SIDE COVER (Page 3-62).
5. Remove seat. See SEAT (Page 3-148).

**REMOVE**

1. **Models with fairing:** See Figure 6-5. Disconnect fuel pump connector (gray) (4).
2. **Models without fairing:** Disconnect fuel pump connector (black) (5). See TOP CADDY (Page 8-107).
3. See Figure 6-6. Remove fuel line from induction module.
  - a. Push fuel line toward fuel rail.
  - b. Release fuel line locking tab.
  - c. Remove fuel line.
4. See Figure 6-7. Remove fuel line from fuel tank.
  - a. Pull up on quick-connect fitting (1).
  - b. Pull down on fuel line.

**INSTALL****A WARNING**

To prevent spray of fuel, be sure quick-connect fittings are properly mated. Gasoline is extremely flammable and highly explosive, which could result in death or serious injury. (00268a)

1. See Figure 6-6. Install fuel line to induction module.
  - a. Push fuel line firmly onto fuel rail inlet fitting. While fuel line is fully seated on the fuel rail, press locking tab.
  - b. Tug hose to verify secure attachment.

2. See Figure 6-7. Install fuel line to fuel tank.
  - a. Connect fuel line (2) to quick disconnect fitting.
  - b. While pushing up on bottom of fitting, pull down on quick connect fitting (1).
  - c. Tug on fuel line to verify fuel line is locked in position.
3. **Models with fairing:** See Figure 6-5. Connect fuel pump connector (gray) (4).
4. **Models without fairing:** Connect fuel pump connector (black) (5). See TOP CADDY (Page 8-107).

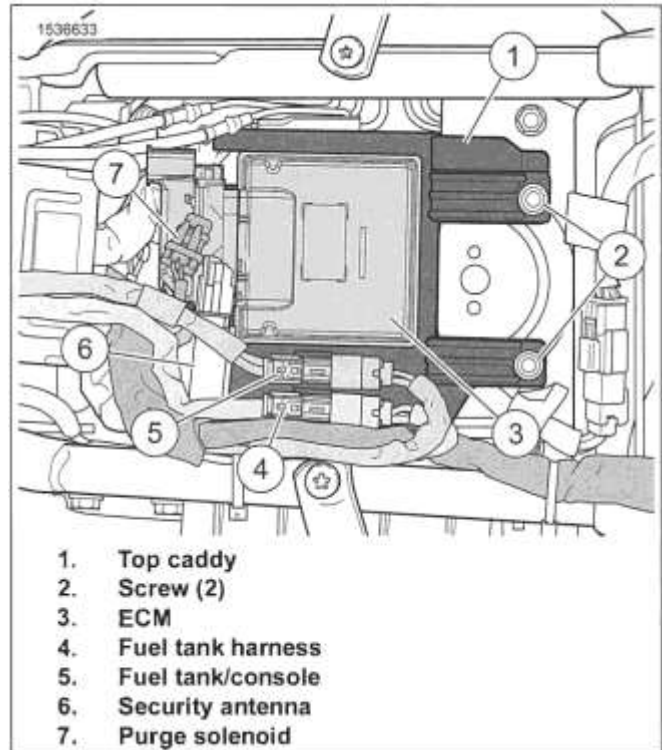


Figure 6-5. Top Caddy

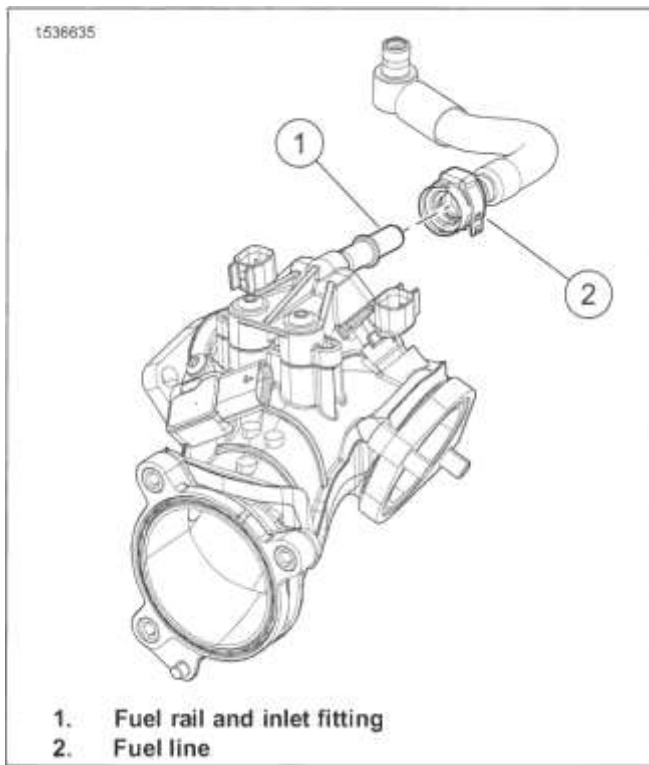


Figure 6-6. Induction Module Assembly

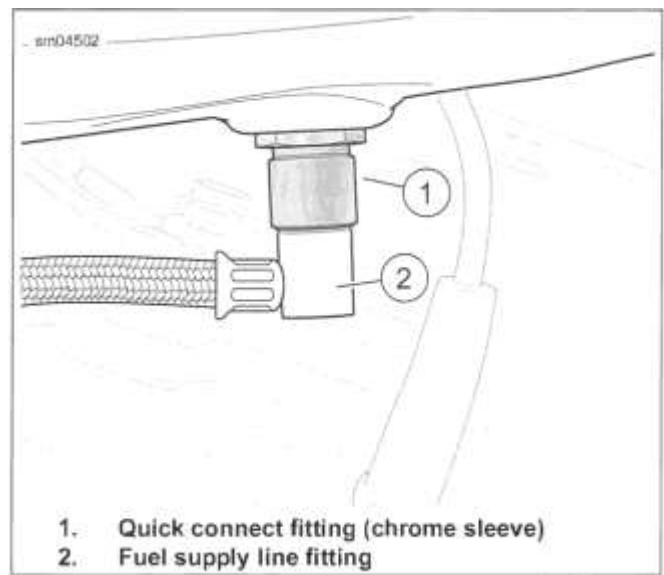


Figure 6-7. Fuel Tank (Left Side View)

**COMPLETE**

1. Install main fuse. See POWER DISCONNECT (Page 8-8).
2. Install seat. See SEAT (Page 3-148).
3. Install left side cover. See LEFT SIDE COVER (Page 3-62).

4. Install left saddlebag. See SADDLEBAGS (Page 3-161).
5. Set OFF/RUN switch to RUN and check for leaks.

## PREPARE

### A WARNING

To prevent spray of fuel, purge system of high-pressure fuel before supply line is disconnected. Gasoline is extremely flammable and highly explosive, which could result in death or serious injury. (00275a)

1. Purge fuel line. See PURGE FUEL LINE (Page 6-7).
2. Remove left side saddlebag. See SADDLEBAGS (Page 3-161).
3. Remove left side cover. See LEFT SIDE COVER (Page 3-62).
4. Remove main fuse. See POWER DISCONNECT (Page 8-8).
5. Disconnect fuel line from tank. See FUEL LINE (Page 6-8).
6. Remove seat. See SEAT (Page 3-148).

## REMOVE

1. Remove vent tube from fitting at the left front corner of the battery box.
2. Disconnect fuel tank connector on the ECM caddy.

### A WARNING

Gasoline can drain from the fuel line when disconnected from fuel tank. Gasoline is extremely flammable and highly explosive, which could result in death or serious injury. Wipe up spilled fuel immediately and dispose of rags in a suitable manner. (00260a)

3. Remove rubber caps from front fuel tank screws.
4. Remove screws.
5. Remove two screws to release rear tank bracket from frame backbone.

6. Remove fuel tank.

## INSTALL

| FASTENER                      | TORQUE VALUE |               |
|-------------------------------|--------------|---------------|
| Fuel tank front screws        | 15-20 ft-lbs | 20.3-27.1 N-m |
| Fuel tank rear bracket screws | 15-20 ft-lbs | 20.3-27.1 N-m |

1. Place fuel tank onto frame backbone and start front fuel tank screws.
2. Install rear fuel tank bracket to frame with two screws. Tighten.  
Torque: 15-20 ft-lbs (20.3-27.1 N-m) *Fuel tank rear bracket screws*
  - a. If removed, install plastic trim cover over bracket.
3. Tighten front fuel tank screws.  
Torque: 15-20 ft-lbs (20.3-27.1 N-m) *Fuel tank front screws*
4. Install rubber caps over screws.
5. Left and right caps are not interchangeable.
6. Install fuel level sender/fuel pump connector to connector on ECM caddy.
7. Install fuel vent tube to valve fitting at left front corner of the battery box.

## COMPLETE

1. Install seat. See SEAT (Page 3-148)
2. Install fuel line. See FUEL LINE (Page 6-8).
3. Install main fuse. See POWER DISCONNECT (Page 8-8).
4. Install left side cover. See LEFT SIDE COVER (Page 3-62).
5. Install left side saddlebag. See SADDLEBAGS (Page 3-161).

## PREPARE

1. Remove seat. See SEAT (Page 3-148).
2. Remove console. See CONSOLE (Page 6-5).
3. Relieve fuel system pressure. See PURGE FUEL LINE (Page 6-7).
4. Remove left saddlebag. See SADDLEBAGS (Page 3-161).
5. Remove left side cover. See LEFT SIDE COVER (Page 3-62).
6. Remove main fuse. See POWER DISCONNECT (Page 8-8).

## REMOVE

1. NOTE

| PART NUMBER | TOOLNAME                   |
|-------------|----------------------------|
| HD-48646    | CAM RING REMOVER/INSTALLER |

See Figure 6-8. Always hold on to both the Cam Ring Remover/Installer and ratchet to prevent unexpected separation resulting in possible fuel tank damage.

Remove cam ring using remover/installer and raise top plate.

Special Tool: CAM RING REMOVER/INSTALLER (HD-48646)

2. Remove connector at bottom of top plate using a small screwdriver.
3. See Figure 6-9. Disconnect ground wire spade terminal from slot of top plate.
4. See Figure 6-10. Press tabs on fuel line retainers (3) to remove lines from fittings on fuel filter shell.
5. If top plate replacement is necessary, remove fuel filter shell. See Disassemble in this section.

## INSTALL

| PART NUMBER | TOOL NAME                  |
|-------------|----------------------------|
| HD-48646    | CAM RING REMOVER/INSTALLER |

1. If installing a **new** top plate, first install fuel filter shell. See Assemble in this section.
2. Inspect seal ring at bottom of top plate for damage. If necessary, install **new** seal ring with nubs contacting ring groove walls.
3. See Figure 6-10. Verify retainers (3) are secure on fuel filter fittings, and not damaged. Note that retainers are of different sizes.

4. Aligning latches and push tubes onto fittings of fuel filter shell until an audible click is heard. Pull on tubes to verify they are attached securely.
5. Install connector at bottom of top plate.
6. Route ground wire (from top plate connector) along inboard side of vapor valve and install spade terminal into slot in top plate.
7. Install fuel tank top plate engaging index tab in slot at front of fuel tank collar.
8. See Figure 6-11. Install cam ring over fuel tank top plate with the TOP stamp up.
9. Engage remover/installer in top plate. Push down and rotate tool clockwise until all tabs begin to engage slots in fuel tank collar.  
Special Tool: CAM RING REMOVER/INSTALLER (HD-48646)

10. NOTE

See Figure 6-8. Always hold on to both the Cam Ring Remover/Installer and ratchet to prevent unexpected separation resulting in possible fuel tank damage.

Install ratchet and rotate until cam ring is fully installed.

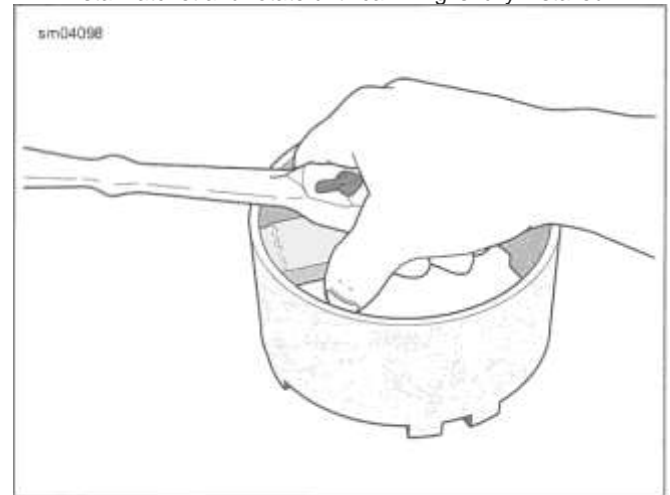


Figure 6-8. Hold Both Tool and Ratchet During Handling

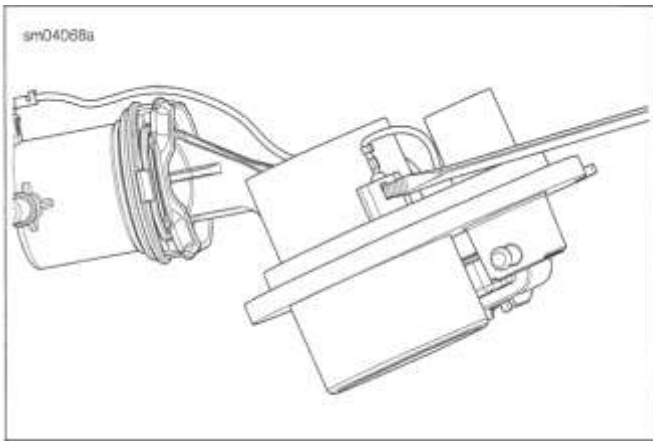


Figure 6-9. Remove Ground Wire Spade Terminal From Top Plate

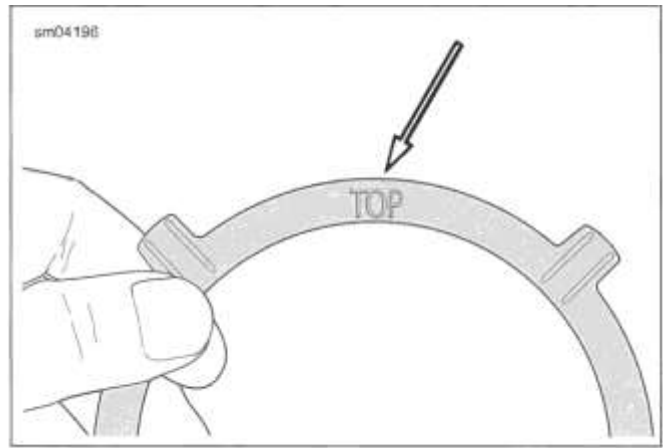
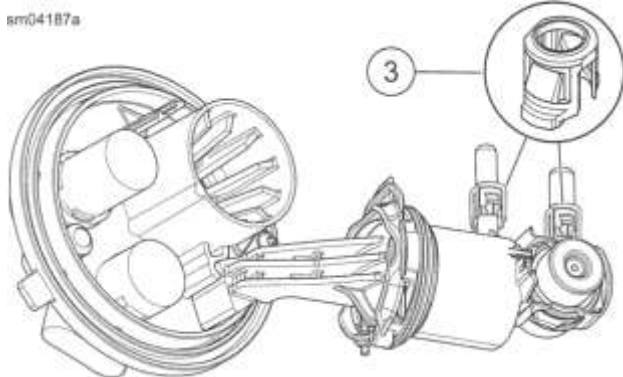


Figure 6-11. Cam Ring Stamp

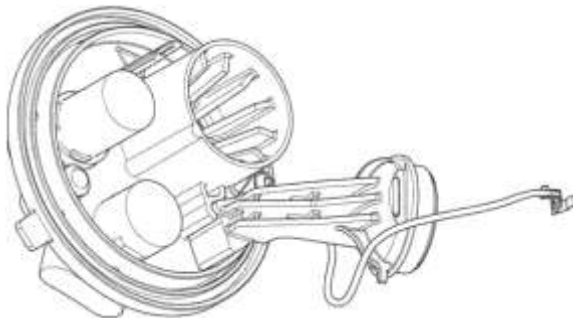
## **DISASSEMBLE**

### **Fuel Filter**

1. See Figure 6-13. Install **new** filter (4) in fuel filter shell (1).
2. Seat O-ring (3) on counterbore at top of filter.
3. Install fuel filter shell over end cap with slot in fuel filter shell engaged index pin on end cap.
4. Install fuel filter shell.
  - a. Holding parts together, slide U-clip (2) through holes on locking arm side of fuel filter shell.
  - b. Push U-clip until ends exit holes on opposite side.
  - c. Retract U-clip until contact is made with locking arm step.
5. **NOTE**  
*If terminal does not lock, use a thin blade to bend tang slightly away from terminal body.*
  - a. Connect ground wire.
    - a. Route ground wire around index pin side of end cap.
    - b. Install spade terminal into slot in fuel filter shell.
    - c. Gently tug on wire to verify that terminal is locked.
6. Inspect strainer. Replace if damaged.



CD



CD

1. **With Fuel Filter Shell**
  2. **Without Fuel Filter Shell**
  3. **Fuel line retainers**
- Figure 6-10. Top Plate Assembly

### **Fuel Pressure Regulator**

1. See Figure 6-14. Insert small O-ring (6) at top of pressure port bore.
2. Install screen (5).
  - a. Install screen (5) at top of pressure regulator bore, with sleeve on ID facing small O-ring.
  - b. Install regulator seat (3) to evenly press screen into bore.



- c. Remove regulator seat.
3. Install large O-ring (4) at top of screen.
  4. Install regulator seat and fuel pressure regulator.
  5. Install spring clip (1), with indented sides engaging top of center rib on fuel pressure regulator. Rounded sides engage bottom of tabs on housing.

6. **NOTE**  
*If terminal does not lock, use a thin blade to bend tang slightly away from terminal body*

Connect ground wire.

- a. Route ground wire around index pin side of end cap.
- b. Install spade terminal into slot in fuel filter shell.
- c. Gently tug on wire to verify that terminal is locked.

## ASSEMBLE

### A WARNING

**Gasoline is extremely flammable and highly explosive. Keep gasoline away from ignition sources which could result in death or serious injury. See the Safety chapter. (00635c)**

### A WARNING

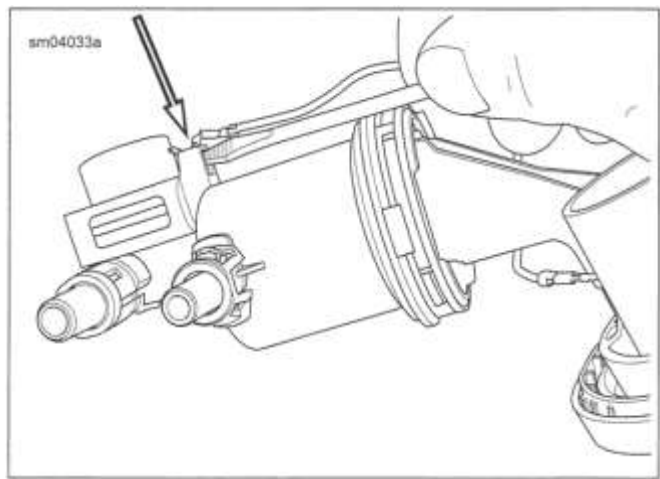
**Do not use solvents or other products that contain chlorine on plastic fuel system components. Chlorine can degrade plastic fuel system components, which can cause a loss of fuel system pressure or engine stalling and could result in death or serious injury. (00621b)**

## Fuel Filter

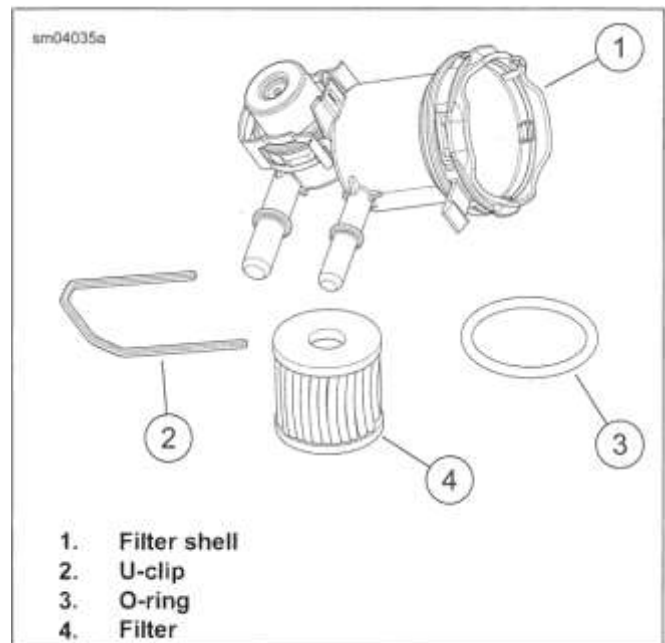
1. See Figure 6-12. Remove ground wire spade terminal from slot of fuel filter shell.
2. See Figure 6-13. Gently raise locking arm and pull U-clip (2) from holes in fuel filter shell.
3. Remove fuel filter shell (1) from end cap.
4. Remove O-ring (3) and filter (4) from fuel filter shell.

## Fuel Pressure Regulator

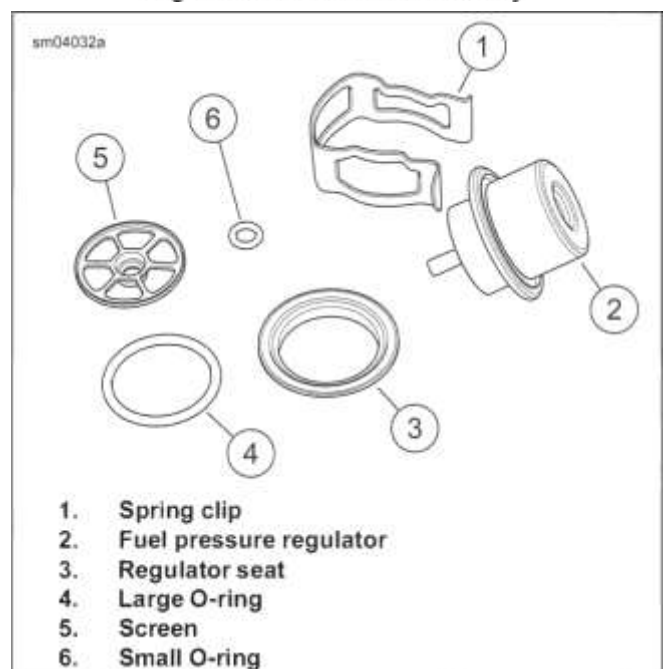
1. See Figure 6-12. Remove ground wire spade terminal from slot of fuel filter shell.
2. See Figure 6-14. Remove spring clip (1) securing fuel pressure regulator.
3. Remove fuel pressure regulator (2), regulator seat (3), large O-ring (4), screen (5) and small O-ring (6).



**Figure 6-12. Remove Ground Wire Spade Terminal From Fuel Filter Shell**



**Figure 6-13. Fuel Filter Assembly**



**Figure 6-14. Fuel Pressure Regulator Assembly**

## COMPLETE

5. Install left saddlebag. See SADDLEBAGS (Page 3-161).

1. Install console. See CONSOLE (Page 6-5).
2. Install seat. See SEAT (Page 3-148).
3. Install main fuse. See POWER DISCONNECT (Page 8-8).
4. Install left side cover. See LEFT SIDE COVER (Page 3-62).

### A WARNING

**Wipe up spilled fuel and dispose of rags in a suitable manner. An open spark around gasoline could cause a fire or explosion, resulting in death or serious injury. (00518b)**

6. Fill fuel tank. Carefully inspect for leaks. Start engine and repeat inspection.

## PREPARE

1. Remove seat. See SEAT (Page 3-148).
2. Remove console. See CONSOLE (Page 6-5).
3. Relieve fuel system pressure. See PURGE FUEL LINE (Page 6-7).
4. Remove left saddlebag. See SADDLEBAGS (Page 3-161).
5. Remove left side cover. See LEFT SIDE COVER (Page 3-62).
6. Remove main fuse. See POWER DISCONNECT (Page 8-8).
7. Remove top plate. See FUEL TANK TOP PLATE (Page 6-11).

## REMOVE

### A WARNING

**Gasoline is extremely flammable and highly explosive. Keep gasoline away from ignition sources which could result in death or serious injury. See the Safety chapter. (00635c)**

1. Disconnect 2-place connector to release fuel level sender from wire harness.

2. **NOTE**  
See Figure 6-15. Look into fuel tank at bracketry. Note that finger (1) on front bracket points forward, while finger on rear bracket points rearward.

Pull up on front finger (1) and slide fuel level sender bracket rearward until four ears on bracket are free of catches at top of tunnel.

3. Remove fuel level sender from left side of fuel tank. See Figure 6-16.

## INSTALL

1. See Figure 6-15. With the finger on the fuel level sender bracket (1) pointing forward, install fuel level sender into left side of fuel tank.
2. Engage four ears on fuel level sender bracket with front set of catches at top of tunnel. Push fuel level sender bracket forward until ears are fully engaged.
3. Connect fuel level sender connector (2) to wire harness.

### NOTE

The low fuel lamp will not turn off until there is sufficient fuel in the tank, the ignition switch has been turned off and back on, and the vehicle has begun forward movement.

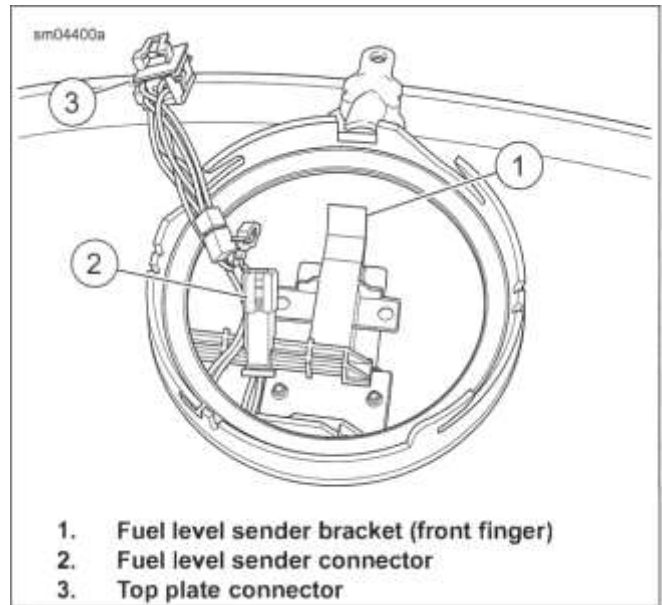


Figure 6-15. Front Finger (Fuel Level Sender Bracket)

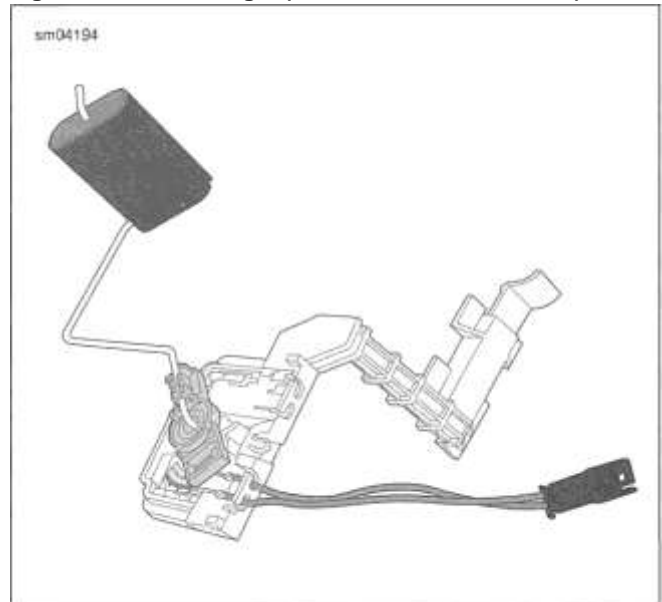


Figure 6-16. Fuel Level Sender

## COMPLETE

1. Install top plate. See FUEL TANK TOP PLATE (Page 6-11).
2. Install main fuse. See POWER DISCONNECT (Page 8-8).
3. Install left side cover. See LEFT SIDE COVER (Page 3-62).
4. Install left saddlebag. See SADDLEBAGS (Page 3-161).
5. Install console. See CONSOLE (Page 6-5).
6. Install seat. See SEAT (Page 3-148).

**A WARNING**

Gasoline is extremely flammable and highly explosive. Keep gasoline away from ignition sources which could result in death or serious injury. See the Safety chapter. (00635c)

**A WARNING**

Do not use solvents or other products that contain chlorine on plastic fuel system components. Chlorine can degrade plastic fuel system components, which can cause a loss of fuel system pressure or engine stalling and could result in death or serious injury. (00621b)

**NOTE**

Carefully inspect tubes for damage. Even a small hole can cause a reduction in fuel pressure. Replace fuel pump as necessary.

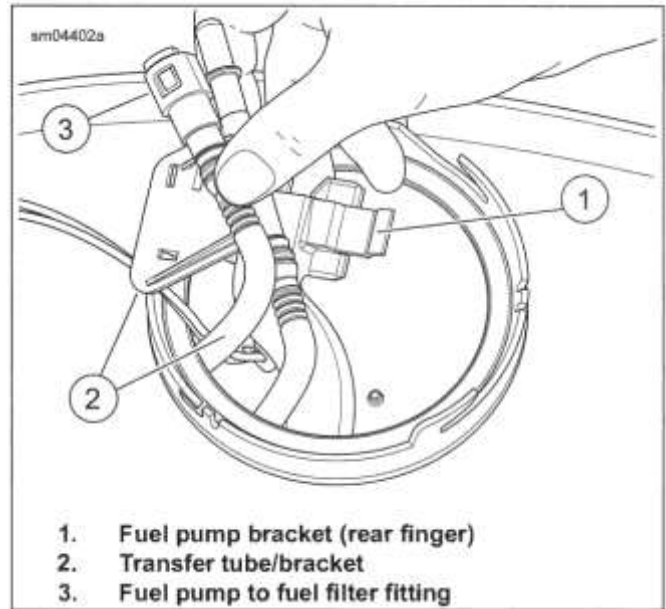
**NOTE**

See the electrical diagnostic manual for information on the function and testing of fuel pump.

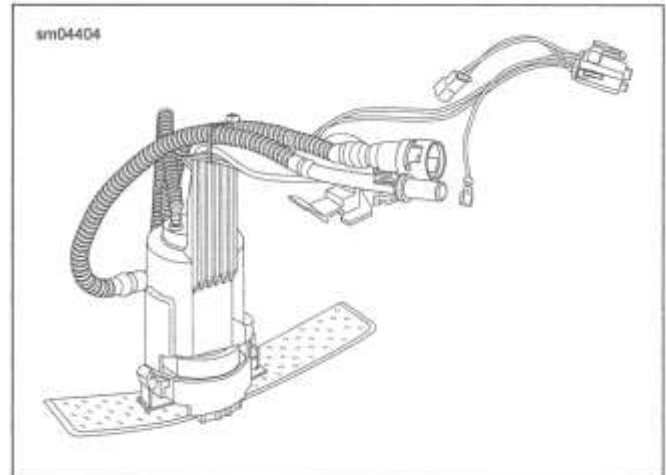
1. Remove top plate. See FUEL TANK TOP PLATE (Page 6-11).
2. Remove fuel level sender. See FUEL LEVEL GAUGE (Page 8-35).

**REMOVE**

1. See Figure 6-17. Press collar on each side of fitting to disconnect transfer tube (2) from bracket.
2. Pull up on rear finger (1) and slide pump bracket (2) forward until four ears are clear of catches at top of tunnel.
3. See Figure 6-18. Remove fuel pump from left side of fuel tank.
  - a. Rotate pump 90 degrees clockwise until transfer tube connection is pointing rearward.
  - b. Remove from fuel tank.
4. Remove fuel pump and fuel level sender wire harness.
  - a. See Figure 6-19. Cut cable strap to release wire harness and both fuel pump and transfer tubes from arm of fuel pump bracket (2).
  - b. Release wire harness from molded clip at front of fuel pump bracket.
  - c. See Figure 6-18. Remove connector at top of fuel bracket.



**Figure 6-17. Rear Finger (Fuel Pump Bracket)**



**Figure 6-18. Fuel Pump Assembly**

**CLEAN AND INSPECT**

1. Carefully inspect tubes for damage.
  - a. See Figure 6-17. Inspect tube (2) for wear.
  - b. Inspect for small hole(s) in tube, which causes a loss of fuel pressure.
2. Replace fuel pump as necessary.
3. See Figure 6-18. Inspect condition of fuel pump wiring.

**NOTE**

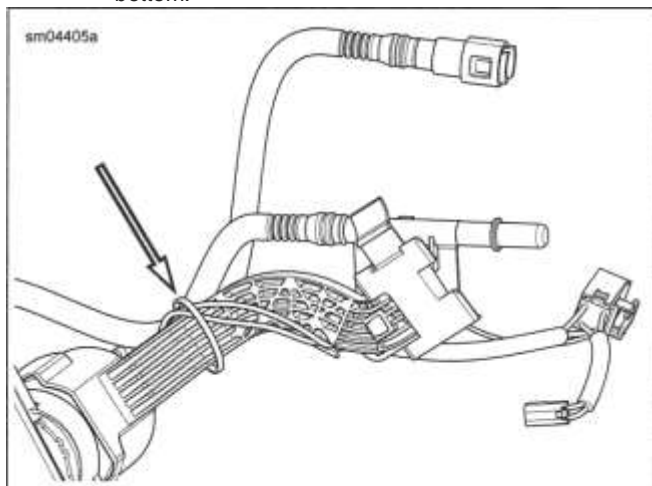
Damaged wiring, terminals and/or connectors requires replacement of wire harness. Do not replace the special Teflon coating wire with ordinary, bulk wire. Ordinary, insulation materials deteriorate when in contact with gasoline.

**NOTE**

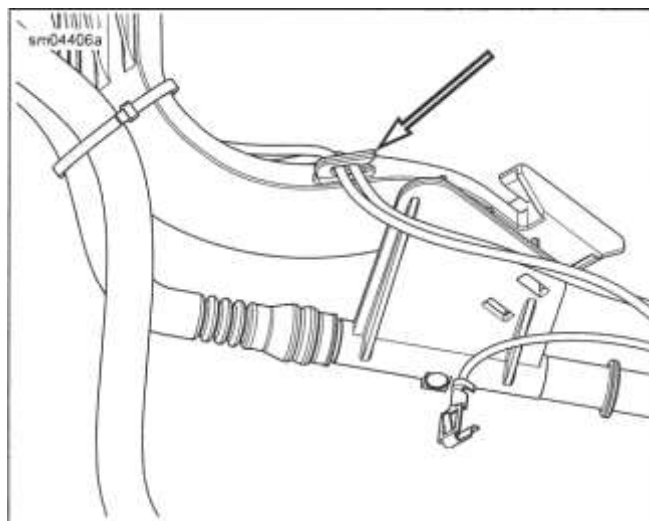
See the electrical diagnostic manual for information on the function and testing of fuel pump.

**INSTALL**

1. Capture wires in cable strap.
  - a. See Figure 6-18. Attach connector at top of fuel pump.
  - b. See Figure 6-19. Route wire harness rearward and then forward under arm of fuel pump bracket. Install new cable strap at elbow capturing fuel pump and transfer tubes at top of arm and wire harness at bottom.
  - c. See Figure 6-20. Route wire harness through molded clip at front of fuel pump bracket.
2. Install fuel pump.
  - a. Hold pump assembly with transfer tube (2) connection pointing rearward and insert into tank.
  - b. Rotate assembly 90 degrees clockwise.
3. Look inside fuel tank to verify that fuel inlet strainer lies flat and ends are not folded under pump.
  - a. See Figure 6-20. Verify that wire harness is still captured in molded clip at front of fuel pump bracket.
4. See Figure 6-17. Secure fuel pump bracket.
  - a. With finger of pump bracket (2) pointing rearward, engage four ears on bracket with rear catches at top of tunnel.
  - b. Push pump bracket (2) rearward until ears are fully engaged.
5. Install transfer tube onto bracket.
  - a. Fit two tabs at bottom of tube bracket into slots at top of pump bracket.
  - b. See Figure 6-20. Verify transfer tube is captured in weld clip on right side of tunnel.
  - c. Verify that free end of tube is in contact with tank bottom.



**Figure 6-19. Capture Wires in Cable Strap**



**Figure 6-20. Capture Wires in Molded Clip**

### **DISASSEMBLE** \_\_\_\_\_

1. Disassemble fuel pump assembly.
2. See Figure 6-17. Remove transfer tube (2).
  - a. Reaching into fuel tank, release tube from weld clip on right side of tunnel.
  - b. Remove tube from tank.
3. Press arms on fuel inlet strainer and remove from slots in fuel pump housing.

### **ASSEMBLE** \_\_\_\_\_

1. See Figure 6-17. Install fuel transfer tube (2).
  - a. Reaching into fuel tank, capture transfer tube in weld clip on right side of tunnel.
  - b. Install fuel inlet strainer to bottom of fuel pump.

### **COMPLETE** \_\_\_\_\_

1. Install fuel level sender. See FUEL LEVEL GAUGE (Page 8-35).

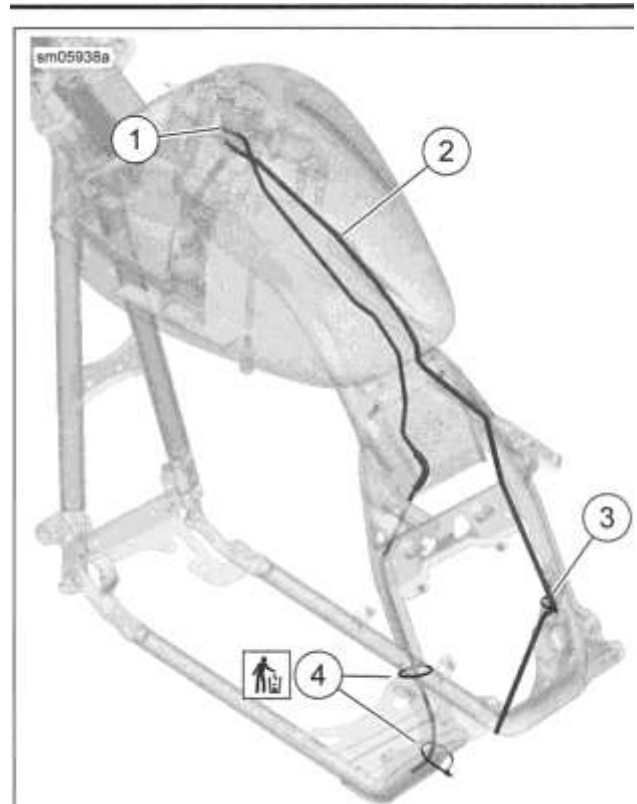
2. Install top plate. See FUEL TANK TOP PLATE (Page6-11).

## PREPARE

1. Remove seat. See SEAT (Page 3-148).
2. Remove console. See CONSOLE (Page 6-5).

## REMOVE

1. See Figure 6-21. Remove vent tube from fitting (1) on fuel tank top plate.
2. Discard two cable straps (4) securing tube to rear frame downtube.
3. Remove tube.
4. Inspect parts for wear or damage. Replace if required.



1. Fuel vent valve fitting
2. Overflow hose
3. Cable strap
4. Cable strap

Figure 6-21. Vent Tube

## INSTALL

1. See Figure 6-21. Route tube down along inner side of rear left downtube.
  - a. Install two **new** cable straps (4) to secure to frame.
2. Route line along center of fuel tank and connect to fitting (1) on fuel tank top plate.

## COMPLETE

1. Install console. See CONSOLE (Page 6-5).
2. Install seat. See SEAT (Page 3-148).

## PREPARE

### NOTE

See Figure 6-22. The valve is not serviceable. Damage or failure of the valve requires replacement of the fuel tank top plate. See FUEL TANK TOP PLATE (Page 6-11).

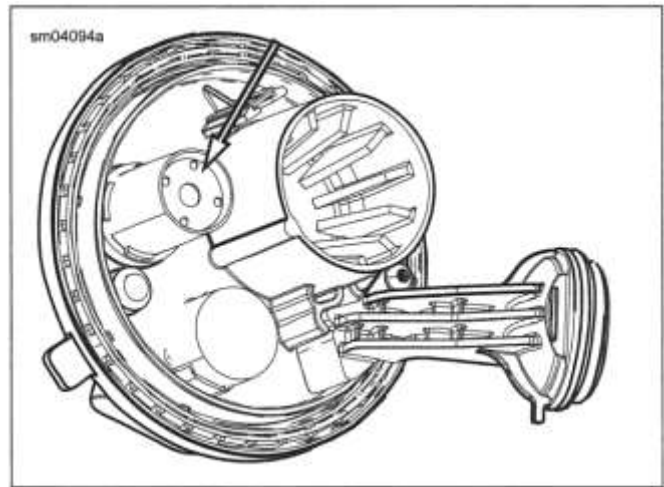


Figure 6-22. Fuel Tank Top Plate with Rollover Valve



# TEMPERATURE MANIFOLD ABSOLUTE PRESSURE (TMAP) SENSOR

## PREPARE

**A WARNING**

Gasoline is extremely flammable and highly explosive. Keep gasoline away from ignition sources which could result in death or serious injury. See the Safety chapter. (00635c)

**A WARNING**

To prevent spray of fuel, purge system of high-pressure fuel before supply line is disconnected. Gasoline is extremely flammable and highly explosive, which could result in death or serious injury. (00275a)

1. Remove main fuse. See POWER DISCONNECT (Page 8-8).
2. Remove seat. See SEAT (Page 3-148).
3. Remove fuel tank. See FUEL TANK (Page 6-10).

## REMOVE

1. Disconnect sensor connector.
2. See Figure 6-23. Remove TMAP sensor.
  - a. Remove screw (2).
  - b. Remove sensor (1).

## INSTALL

| FASTENER  | TORQUE VALUE |             |
|---|--------------|-------------|
| Temperature manifold absolute pressure (TMAP) screw | 22-40 in-lbs | 2.5-4.5 N-m |

1. See Figure 6-23. Install TMAP sensor.
  - a. Install sensor.

1. Install fuel tank. See FUEL TANK (Page 6-10).

- b. Install screw (2). Tighten.

Torque: 22-40 in-lbs (2.5-4.5 N-m) *Temperature manifold absolute pressure (TMAP) screw*

2. Connect sensor connector.

## COMPLETE

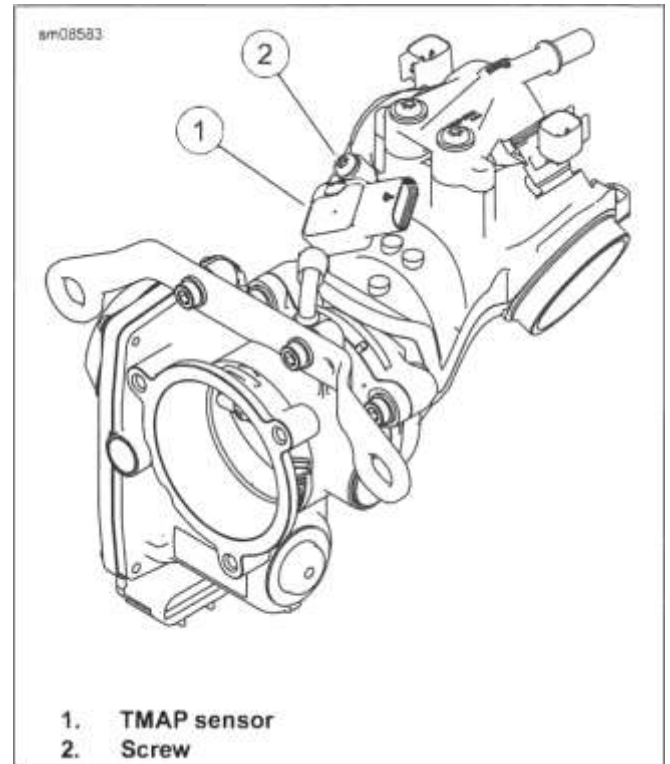


Figure 6-23. TMAP Sensor

2. Install seat. See SEAT (Page 3-148).
3. Install main fuse. See POWER DISCONNECT (Page 8-8).

## PREPARE

1. Remove main fuse. See POWER DISCONNECT (Page 8-8).
2. Remove right switch housing and front brake control from the handlebar. See RIGHT HAND CONTROL MODULE (RHCM) (Page 8-25).
3. Models with heated hand grips: Pull out hand grip connector.
  - a. Pry end cap from hand grip.
  - b. Pull connector out through hand grip end.
  - c. Do not disconnect heated hand grip power or interconnect connectors. See HAND GRIPS (Page 3-123).

## REMOVE

1. Remove right hand grip.
2. Road King models: See Figure 6-24.
  - a. Remove harness retainers from right side of handlebar.
  - b. Remove headlamp and handlebar clamp shroud. See HEADLAMP NACELLE (Page 3-87).
  - c. Disconnect TGS connector (2). Cut cable strap securing harness to right riser.
  - d. Remove cable strap gathering TGS harness.
3. Fork-mounted fairing models:
  - a. Remove outer fairing.
  - b. See Figure 6-25. Disconnect TGS connector.
  - c. Rotate inner fairing. See FAIRING: FORK MOUNTED (Page 3-89).
  - d. Cut cable straps securing TGS harness.
4. Frame-mounted fairing models:
  - a. Remove instrument bezel. See FAIRING: FRAME MOUNTED (Page 3-100).
  - b. See Figure 6-26. Disconnect TGS connector (1).
  - c. Remove cable strap gathering TGS harness.
5. Models with heated hand grips: Disconnect heated hand grip jumper harness connector.

6. Remove TGS.
  - a. Attach a chaser wire to TGS connector.
  - b. Pull TGS and harness out of handlebar.

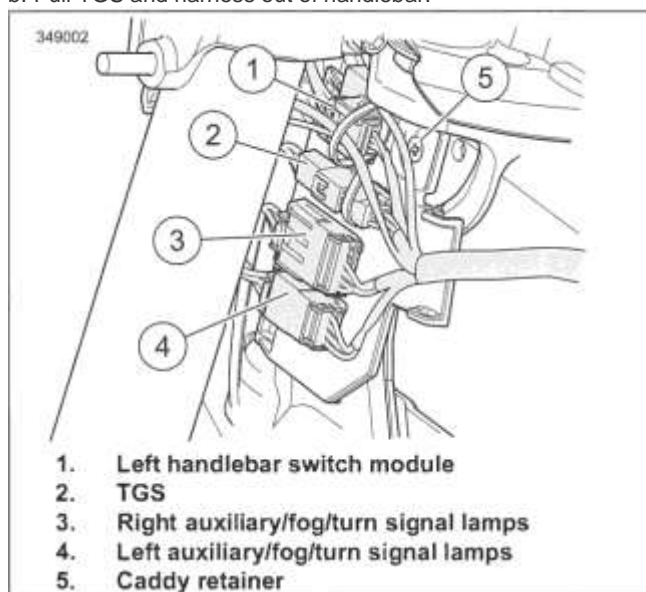


Figure 6-24. Left Side Connectors: Road King

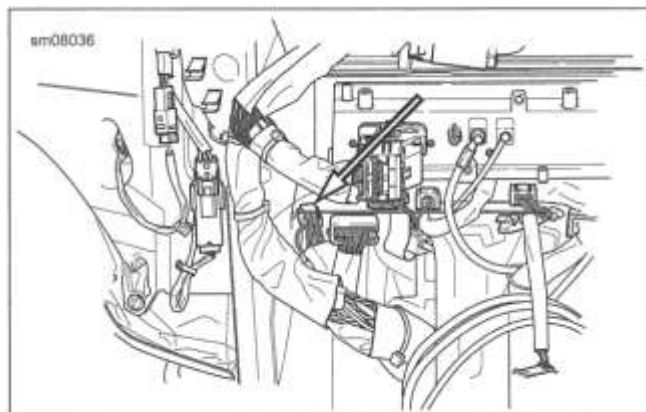


Figure 6-25. TGS Connector: Fork-Mounted Fairing Models

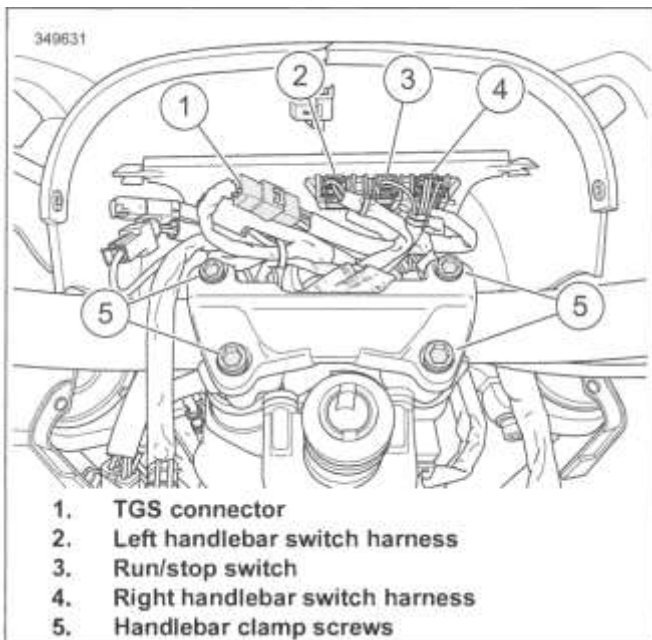


Figure 6-26. Handlebar Harness Connectors: Frame-Mounted Fairing Models

## INSTALL

### NOTE

Never use any kind of lubricant or spray cleaner on the twist grip, handlebar or TGS. All parts are designed to operate dry.

See Figure 6-27. The seal cap serves two functions; cap protects TGS terminals from dirt and moisture and is a retention device for throttle grip.

1. Install seal cap at end of TGS. If seal cap is not present, remove from inside throttle grip.
  - a. Check condition of O-ring on seal cap. (available only as part of seal cap assembly)
  - b. See Figure 6-27. Install seal cap into slots.
2. See Figure 6-28. Install TGS.
  - a. Draw harness into handlebar while guiding TGS into end of handlebar.
  - b. Align index tabs on TGS in handlebar.
  - c. Verify that TGS is completely engaged into handlebar.
3. Connect TGS connector.
4. Install hand grip.

### NOTE

Always follow the procedure in **RIGHT HAND CONTROL MODULE (RHCM)** (Page 8-25) when installing right switch housing ensuring twist grip operates correctly

- a. Install hand grip properly positioned.
- b. Rotate to verify internal splines are engaged with TGS.

Figure 6-27. Models with Seal Cap Grips: Models without Seal Cap Grips

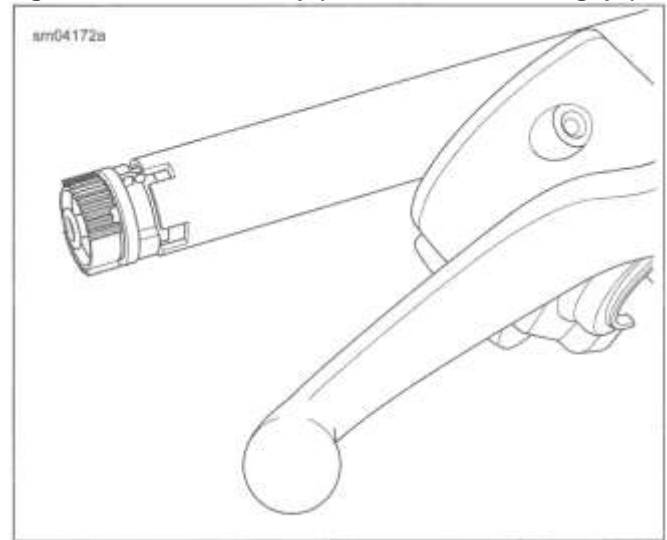


Figure 6-28. Install Twist Grip Sensor



## 6. Road King Models:

- a. Install handlebar clamp shroud and headlamp. See **HEADLAMP NACELLE** (Page 3-87).
- b. Install cable clips on harnesses and into holes in handlebar.
- c. Attach TGS harness and brake line to right handlebar riser with a **new** cable strap.
- d. See Figure 6-24. Connect TGS.
- e. See Figure 6-29. Loop TGS harness onto itself.
- f. Install **new** cable strap (2).

7. Fork-mounted fairing models:
  - a. Rotate inner fairing. See FAIRING: FORK MOUNTED (Page 3-89).
  - b. See Figure 6-25. Connect TGS.
  - c. Install outer fairing.
  - d. See Figure 6-29. Fold TGS harness (3) across handlebar. Secure with new cable straps (1).

8. Frame-mounted fairing models:
  - a. See Figure 6-26. Connect TGS connector (1).
  - b. See Figure 6-30 Loop TGS harness onto itself.
  - c. Install new cable strap (2).
  - d. Install instrument bezel. See FAIRING: FRAME MOUNTED (Page 3-100).

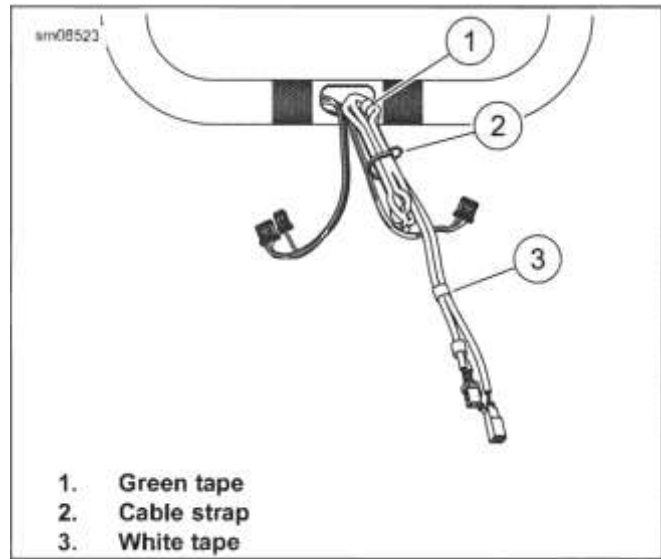


Figure 6-30. Secure TGS Harness (Typical)

**COMPLETE**

1. Install main fuse. See POWER DISCONNECT (Page 8-8).

**NOTE**

Whenever a **new** TGS or ECM is installed, idle speed must be reset. The ECM uses the first four ignition cycles to establish optimum idle speed. If the procedure is not performed, initial performance problems may result.

2. Reset idle speed.
  - a. Place engine in run/stop switch in RUN position.
  - b. Turn ignition/light switch to IGNITION position and then back to OFF four times without starting engine. Allow a minimum of three seconds to elapse between ignition cycles.
  - c. Start engine to verify installation.

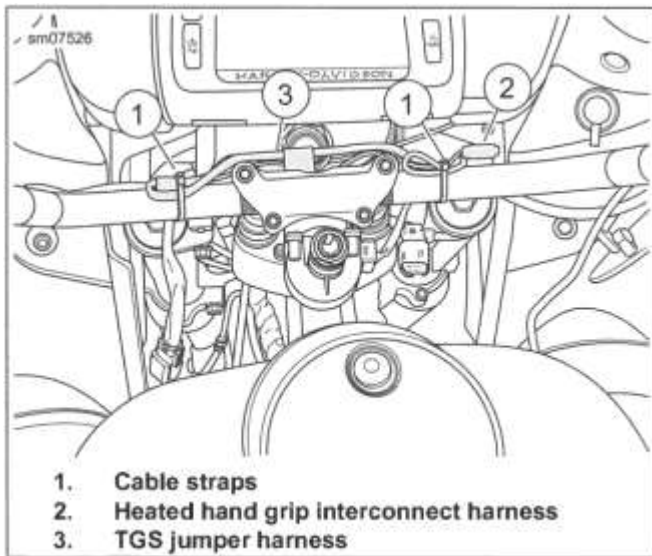


Figure 6-29. Secure Harness to Handlebar

**PREPARE**

**A WARNING**

Gasoline is extremely flammable and highly explosive. Keep gasoline away from ignition sources which could result in death or serious injury. See the Safety chapter. (00635c)

**A WARNING**

To prevent spray of fuel, purge system of high-pressure fuel before supply line is disconnected. Gasoline is extremely flammable and highly explosive, which could result in death or serious injury. (00275a)

1. Remove seat. See SEAT (Page 3-148).
2. Remove fuel tank. See FUEL TANK (Page 6-10).
3. Remove main fuse. See POWER DISCONNECT (Page 8-8).

**REMOVE**

1. Disconnect fuel injector connectors.
2. See Figure 6-31. Remove fuel rail and fuel injectors.
  - a. Remove screws (2).
  - b. Remove fuel rail (3).
  - c. Remove fuel injectors (1, 5).
3. Discard all O-rings (4, 6) from fuel rail (3).

**INSTALL**

1. See Figure 6-31. Install fuel injectors to intake manifold.

| FASTENER        | TORQUE VALUE                      |
|-----------------|-----------------------------------|
| Fuel rail screw | 30-50 <b>in-lbs</b>   3.5-5.5 N-m |

- a. Install **new** O-rings (4, 6) into intake manifold.
  - b. Install fuel injectors (1, 5) to intake manifold.
2. Install fuel rail. a. Install rail (3).

- b. Install screws (2). Tighten.

Torque: 30-50 **in-lbs** (3.5-5.5 N-m) *Fuel rail screw*

3. Connect fuel injector connectors. a. Grey connector to front injector.
- b. Black connector to rear injector.

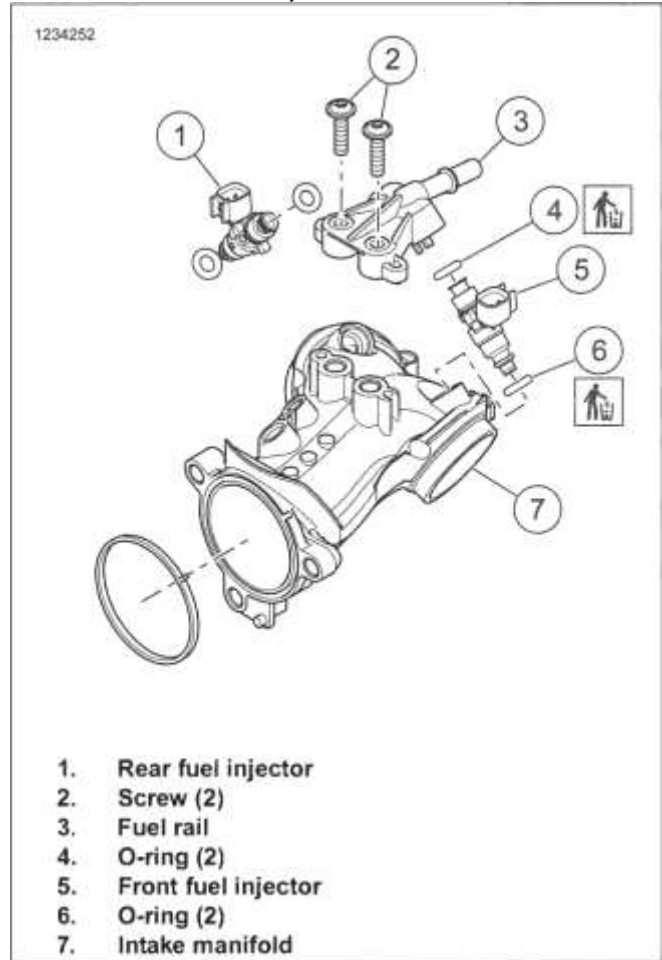


Figure 6-31. Fuel Injectors

**COMPLETE**

1. Install fuel tank. See FUEL TANK (Page 6-10).
2. Install seat. See SEAT (Page 3-148).
3. Install main fuse. See POWER DISCONNECT (Page 8-8).

1. Remove fuel tank. See FUEL TANK (Page 6-10).
2. Remove air cleaner and backplate. See INSPECT AIR FILTER (Page 2-46).

## REMOVE

1. See Figure 6-32. **California models:** Pull purge line from

| PART NUMBER | TOOLNAME                    |
|-------------|-----------------------------|
| HD-35801    | INTAKE MANIFOLD SCREWDRIVER |

fitting (13).

2. Disconnect connectors:

### NOTE

See Figure 6-33. For best results, use intake manifold screwdriver. INTAKE MANIFOLD SCREWDRIVER (PART NUMBER: HD-35801)

- a. TMAP sensor connector.

- b. Front fuel injector connector.
  - c. Rear fuel injection connector.
  - d. Disconnect TCA connector (11). Release harness from anchor point (12).
3. Remove induction module:
    - a. See Figure 6-32. Remove right side screws (3).
    - b. Remove left side screws (4).
    - c. Remove module from right side.
  4. Discard seals (1). Remove flange adapters (2, 9).
  5. Disconnect fuel line from induction module:
    - a. Push fuel line toward fuel rail.
    - b. Release fuel line locking tab.
    - c. Pull fuel line from fuel rail inlet fitting.

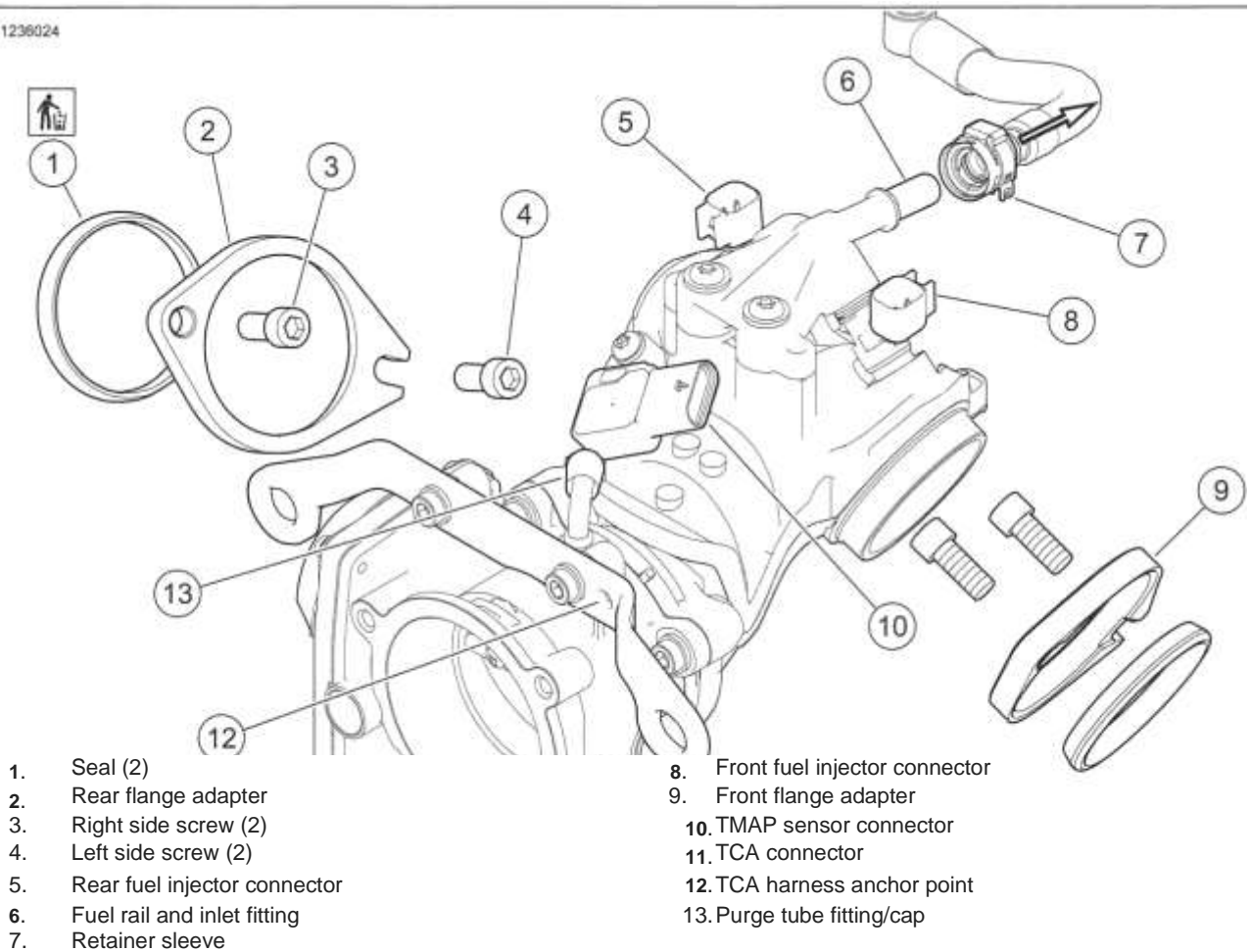


Figure 6-32. Induction Module Assembly

1. See Figure 6-32 Connect fuel line to induction module.

sm08590



Figure 6-33. Intake Manifold Wrench

**INSTALL**

| PART NUMBER | TOOL NAME                   |
|-------------|-----------------------------|
| HD-35801    | INTAKE MANIFOLD SCREWDRIVER |

| FASTENER                                | TORQUE VALUE  |               |
|---|---------------|---------------|
| Induction module flange adapter screws. | 96-156 in-lbs | 10.9-17.6 N-m |

**NOTE**

See Figure 6-33. For best results use special tool. **INTAKE MANIFOLD SCREWDRIVER (PARTNUMBER: HD-35801)**

- a. Push fuel line firmly onto fuel rail inlet fitting (6). While fuel line is fully seated on the fuel rail, press locking tab.
  - b. Pull on hose to verify that it is securely attached.
2. With counter-bore facing outward, install flange adapters (2, 9) onto induction module.
  3. Place new seal (1) in each flange adapter with beveled side against counter-bore.
  4. Install induction module.
    - a. Slide induction module into position until slots engage left side screws (4).
    - b. Start right side screws (3).

- c. Temporarily fasten mounting bracket to cylinder heads with breather bolts.
5. Tighten right side screws (3) finger tight.
  6. Install left side screws (4). Tighten.  
Torque: 96-156 in-lbs (10.9-17.6 N-m) *Induction module flange adapter screws.*
  7. Tighten right side screws (3).  
Torque: 96-156 in-lbs (10.9-17.6 N-m) *Induction module flange adapter screws.*
  8. See Figure 6-32 Make connections.
    - a. Rear fuel injector connector (5).
    - b. Front fuel injector connector (8).
    - c. TMAP sensor connector (10).
    - d. TCA connector (11).
    - e. Fasten TCA harness to anchor point (12) with new anchored cable strap.
    - f. California Emissions Models: Connect purge tube to fitting (13).

## DISASSEMBLE

### Throttle Body

#### NOTE

*The throttle body can be removed without removing the entire induction module.*

1. See Figure 6-34. Induction module still in place: Disconnect TCA connector (12).
2. Remove bracket (1) from induction assembly.
  - a. Remove screws (2).
  - b. Remove bracket.
3. Remove throttle body (4).
  - a. Remove screws (3).
  - b. Remove throttle body.

- c. California models: Disconnect vent hose.
- d. Discard gasket (6).

### Induction Manifold

1. See Figure 6-34. Remove TMAP sensor (7). See TEMPERATURE MANIFOLD ABSOLUTE PRESSURE (TMAP) SENSOR (Page 6-21).
2. Remove fuel rail (9) and fuel injectors (8, 10). See FUEL INJECTORS (Page 6-25).

## ASSEMBLE

| FASTENER                         | TORQUE VALUE |             |
|----------------------------------|--------------|-------------|
| Induction module screw           | 66-84 in-lbs | 7.5-9.5 N-m |
| Throttle body to manifold screws | 35-53 in-lbs | 4-6 N-m     |

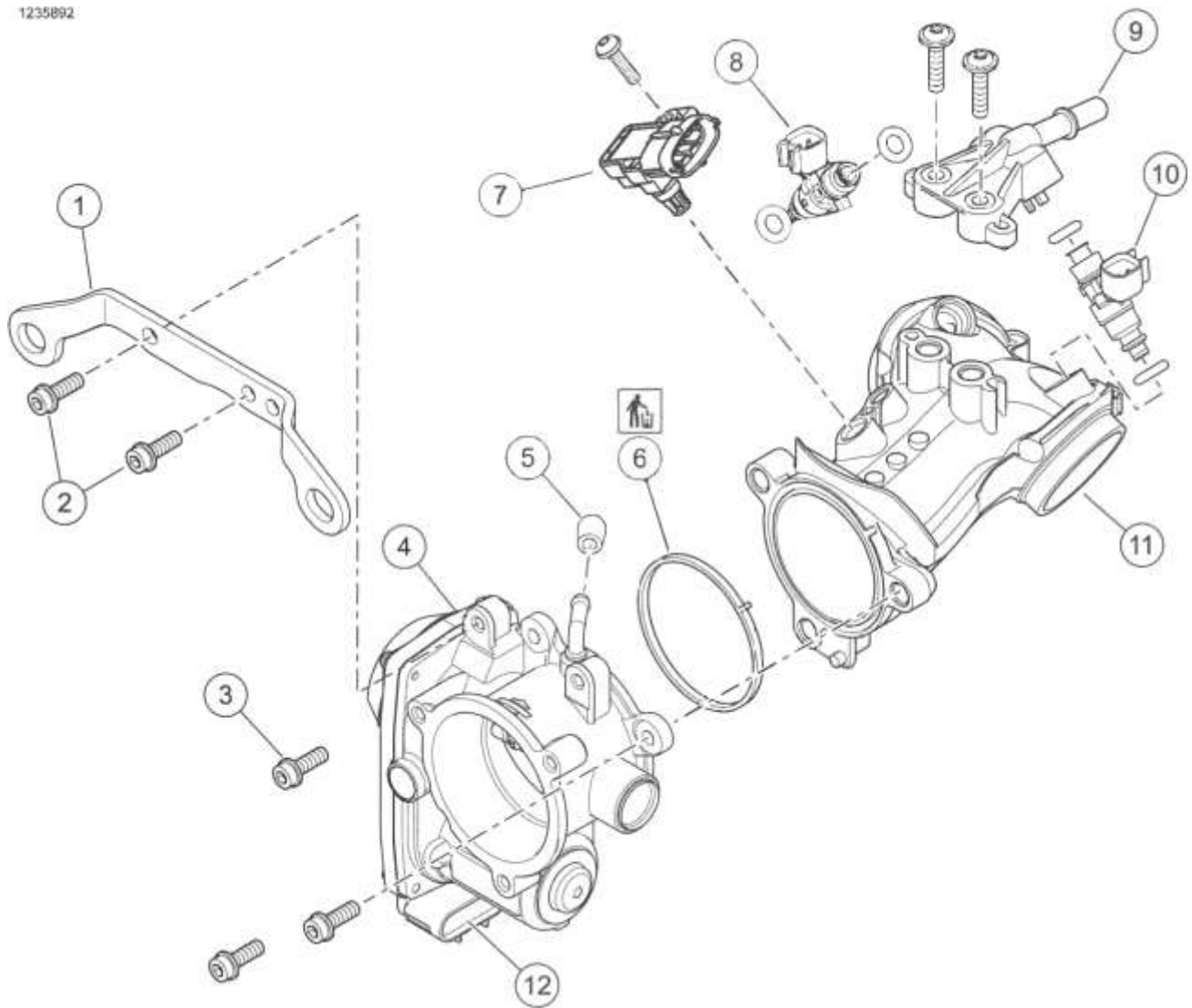
### Induction Manifold

1. See Figure 6-34. Install TMAP sensor (7). See TEMPERATURE MANIFOLD ABSOLUTE PRESSURE (TMAP) SENSOR (Page 6-21).
2. Install fuel rail (9) and fuel injectors (8, 10). See FUEL INJECTORS (Page 6-25).

### Throttle Body

1. Install new gasket (6).
  - a. Install throttle body (4).
  - b. Install screws (3).  
Torque: 35-53 in-lbs (4-6 N-m) *Throttle body to manifold screws*
  - c. California models: Connect vent hose.
  - d. If removed, install new rubber cap (5) or connect vent hose.
2. Install bracket (1) with screws (2).
  - a. Install screws (2). Tighten.  
Torque: 66-84 in-lbs (7.5-9.5 N-m) *Induction module screw*
3. Induction module still installed: Connect TCA connector (12).





- |                          |                         |
|--------------------------|-------------------------|
| 1. Bracket (if equipped) | 7. TMAP sensor          |
| 2. Screw (2)             | 8. Rear fuel injector   |
| 3. Screw (3)             | 9. Fuel rail            |
| 4. Throttle body         | 10. Front fuel injector |
| 5. Rubber cap            | 11. Intake manifold     |
| 6. Gasket                | 12. TCA connector       |

**Figure 6-34. Induction Module Assembly**

## COMPLETE

1. Install fuel tank. See FUEL TANK (Page 6-10).
2. Install air cleaner assembly. See INSPECT AIR FILTER (Page 2-46).

**LEAK TESTER**

| PART NUMBER | TOOL NAME              |
|-------------|------------------------|
| HD-41417    | PROPANE ENRICHMENT KIT |

**A WARNING**

Do not allow open flame or sparks near propane. Propane is extremely flammable, which could cause death or serious injury. (00521b)

**A WARNING**

Read and follow warnings and directions on propane bottle. Failure to follow warnings and directions can result in death or serious injury. (00471b)

**Parts List**

- Small propane cylinder.
- PROPANE ENRICHMENT KIT (PART NUMBER: HD-41417).

**Tester Assembly**

1. See Figure 6-35. Make sure valve knob (6) is closed (fully clockwise).
2. Install valve assembly (5) onto propane bottle (1).

**Tester Adjustment**

1. See Figure 6-35. Press and hold trigger button (8).
2. Slowly open valve knob (6) until pellet in flow gauge (7) rises 5-10 SCFH on gauge.
3. Release trigger button.

**PROCEDURE**

*NOTE*

Propane injected into air cleaner causes false readings. Keep air cleaner cover installed.

1. Run motorcycle until engine is at normal operating temperature.
2. Aim nozzle toward possible sources of leak.

*NOTE*

The tone of the engine changes when propane enters source of leak.

3. Press and release trigger button to dispense propane.
4. Repeat as necessary to detect leak.
5. When test is finished, close valve.

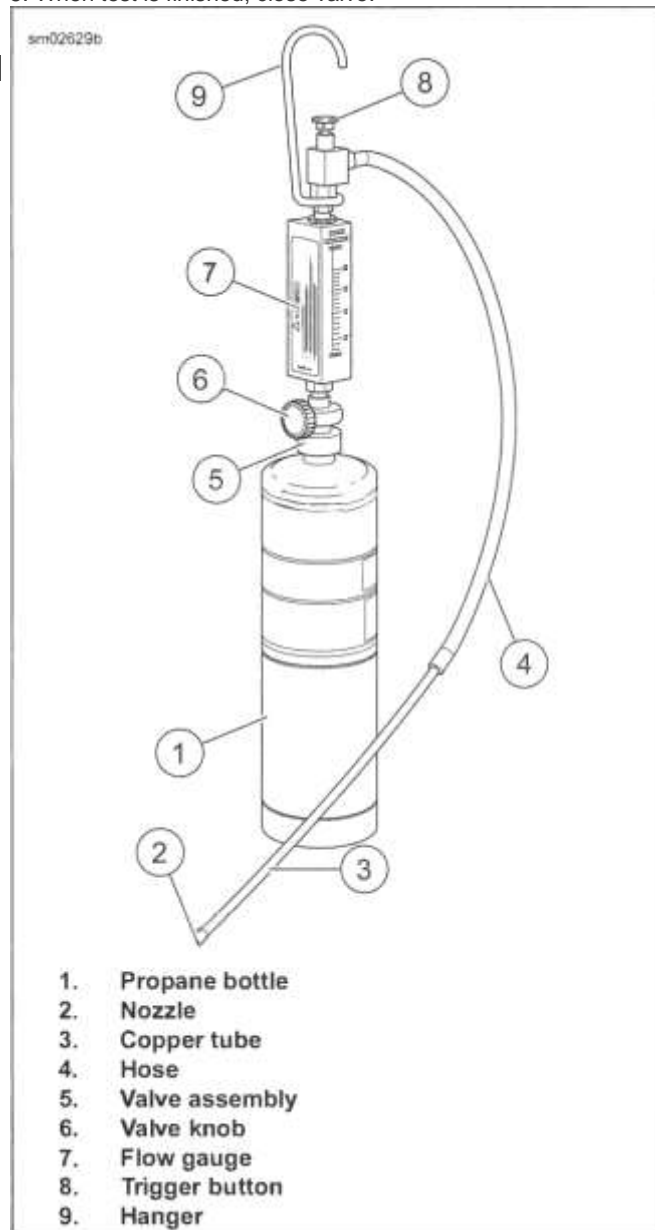


Figure 6-35. Leak Tester

**PREPARE**

1. Remove main fuse. See POWER DISCONNECT (Page 8-8).

**REMOVE**

| PART NUMBER | TOOL NAME                 |
|-------------|---------------------------|
| HD-52977    | 17MM OXYGEN SENSOR SOCKET |

**Rear H02 Sensor**

1. See Figure 6-36. Remove rear Heated Oxygen Sensor (HO2S).
2. Discard cable straps (9,10).
3. Disconnect HO2S connector (2).
4. Remove HO2S (3) using special tool.  
Special Tool: 17MM OXYGEN SENSOR SOCKET (HD-52977)

**Front H02 Sensor**

1. See Figure 6-36. Remove front HO2S.
2. Discard cable straps (7-9).
3. Disconnect HO2S connector (1).
4. Remove HO2S (6) using special tool.  
Special Tool: 17MM OXYGEN SENSOR SOCKET (HD-52977)

**Third H02 Sensor (if equipped) Typical**

1. See Figure 6-37. Remove third HO2S.
2. Discard cable straps.
3. Disconnect HO2S connector (2).
4. Remove HO2S (1) using special tool.  
Special Tool: 17MM OXYGEN SENSOR SOCKET (HD-52977)

**INSTALL**

| PART NUMBER | TOOL NAME                 |
|-------------|---------------------------|
| HD-52977    | 17MM OXYGEN SENSOR SOCKET |

| FASTENER              | TORQUE VALUE |           |
|-----------------------|--------------|-----------|
| Oxygen sensor, heated | 12-14 ft-lbs | 16-19 N-m |

| PART NUMBER | CONSUMABLE           |
|-------------|----------------------|
| 98960-97    | ANTI-SEIZE LUBRICANT |

**NOTE**

- Do not install sensors that have dropped or have been impacted by other components. Damage to the sensing element can occur.
- Replacement sensor assemblies have threads coated with ANTI-SEIZE LUBRICANT (98960-97) and **new** gaskets.
- If reusing HO2S, replace the gasket. Use a high-quality professional grade side cutter for gasket removal. Make sure larger side of **new** gasket faces exhaust.
- If reusing HO2S, apply a thin coat of ANTI-SEIZE LUBRICANT (98960-97) to each oxygen sensor.

**Front H02 Sensor**

1. See Figure 6-36. Install HO2S (6) using special tool. Tighten.  
Torque: 12-14 ft-lbs (16-19 N-m) Oxygen sensor, heated  
Special Tool: 17MM OXYGEN SENSOR SOCKET (HD-52977)
2. Route wire harness.
  - a. Route harness along lower frame and above rear engine mount.
3. Connect front HO2S connector (1).
4. Secure harness.
  - a. Install harness in clips (4) and multi-clamp (5).
  - b. Install **new** cable straps (7-9).

**Rear H02 Sensor**

1. See Figure 6-36. Install HO2S (3) using special tool. Tighten.  
Torque: 12-14 ft-lbs (16-19 N-m) Oxygen sensor, heated  
Special Tool: 17MM OXYGEN SENSOR SOCKET (HD-52977)
2. Route wire harness.
  - a. Route harness along top of transmission to neutral switch area.
3. Connect rear HO2S connector (2).
4. Secure harness.
  - a. Install **new** cable straps (9,10).

**Third H02 Sensor (if equipped) Typical**

1. See Figure 6-37. Install HO2S (1) using special tool. Tighten.  
Torque: 12-14 ft-lbs (16-19 N-m) Oxygen sensor, heated  
Special Tool: 17MM OXYGEN SENSOR SOCKET (HD-52977)

2. Route wire harness.

4. Secure harness.

3. Connect rear HO2S connector (2).

a. Install **new** cable straps.

- 1. Front HO2S connector (grey)
- 2. Rear HO2S connector (black)
- 3. Rear HO2S
- 4. Clips
- 5. Multi-clamp

- 6. Front HO2S
- 7. Cable strap
- 8. Cable strap
- 9. Cable strap
- 10. Cable strap

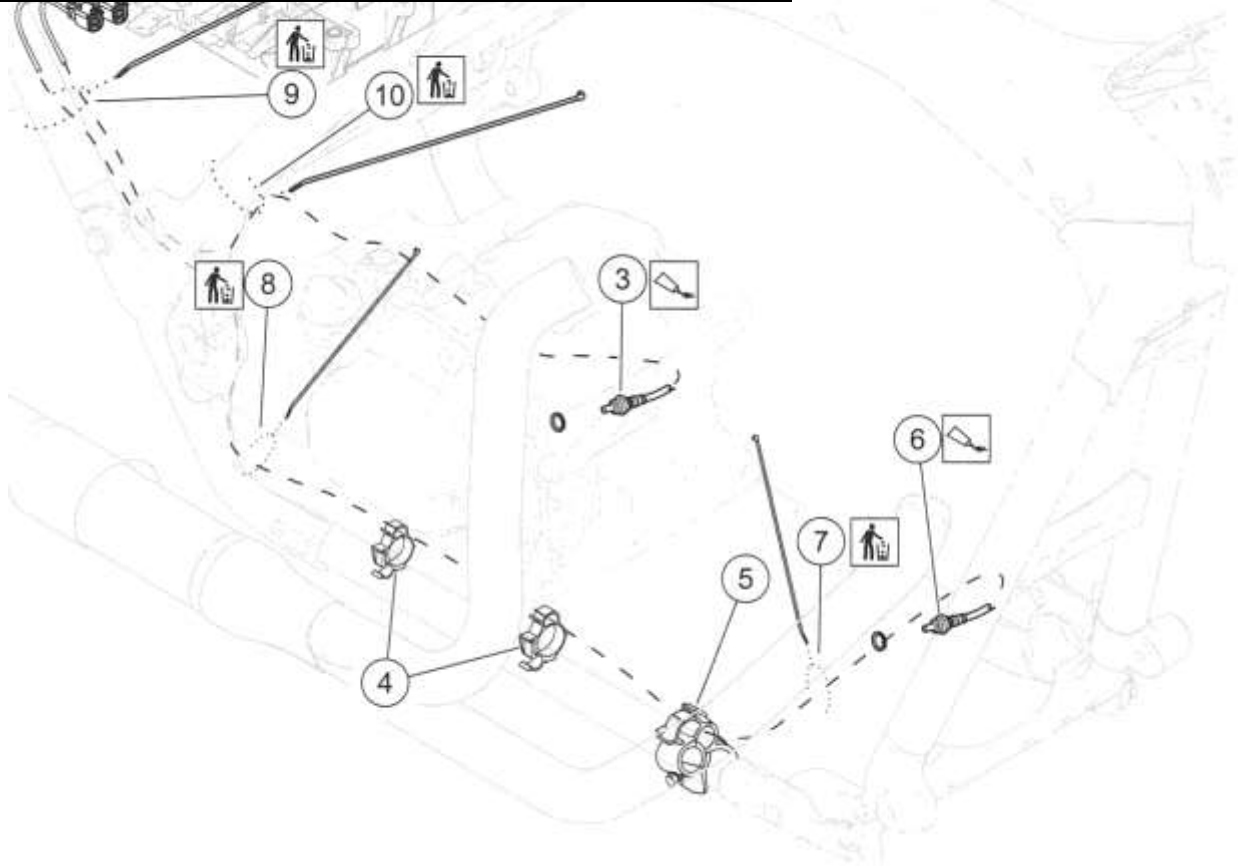
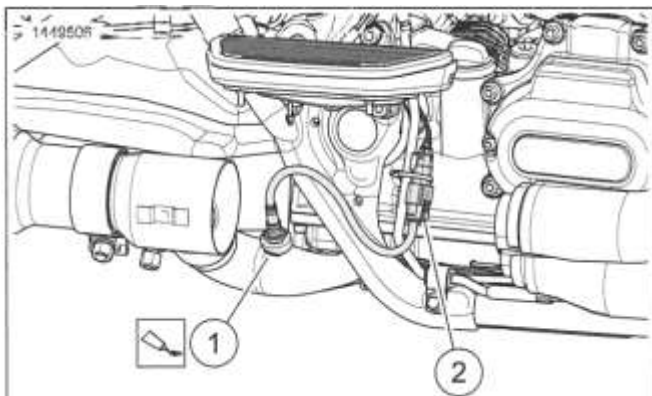


Figure 6-36. Oxygen Sensors (typical)

- 1. HO2S
- 2. HO2S connector

Figure 6-37. Third Heated Oxygen Sensor (if equipped) typical



**COMPLETE**

- 1. Install main fuse. See POWER DISCONNECT (Page 8-8).

## PREPARE

1. Remove saddlebags. See SADDLEBAGS (Page 3-161).

## REMOVE

1. See Figure 6-38. Remove muffler.
  - a. Remove screws (1) and lock washers (2).
  - b. Loosen clamp (7).
  - c. Remove muffler (5).
  - d. Discard clamp.
  - e. Discard gasket (6).
2. Inspect rubber mount (3). Replace if required.

## INSTALL

| FASTENER                            | TORQUE VALUE |               |
|-------------------------------------|--------------|---------------|
| Muffler to clamp                    | 38-43 ft-lbs | 51.5-58.3 N-m |
| Muffler to saddlebag support screws | 14-18 ft-lbs | 19-24.4 N-m   |

1. See Figure 6-38. Install muffler.
  - a. Install **new** gasket (6) in muffler (5).

- b. Slide **new** clamp (7) onto muffler.
- c. Install muffler to bracket (4) with screws (1) and lock washers (2). Tighten. 14-18 ft-lbs (19-24.4 N-m)
- d. Position clamp block (8) away from slot as shown. Tighten. 38-43 ft-lbs (51.5-58.3 N-m)

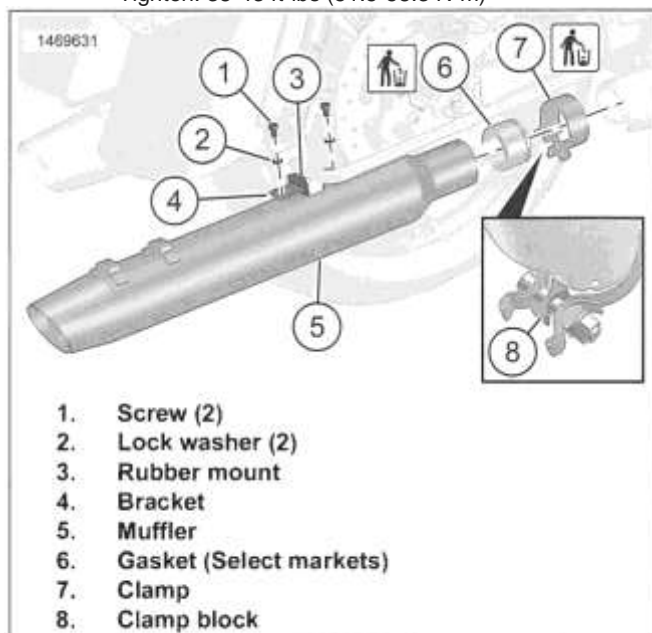


Figure 6-38. Muffler

## COMPLETE

1. Install saddlebags. See SADDLEBAGS (Page 3-161).



## PREPARE

1. Remove main fuse. See POWER DISCONNECT (Page 8-8).
2. Remove saddlebags. See SADDLEBAGS (Page 3-161).
3. Remove mufflers. See MUFFLERS (Page 6-33).
4. Remove seat. See SEAT (Page 3-148).
5. Remove right side rider footboard and brackets from frame. See RIDER FOOTRESTS (Page 3-142).
6. Disconnect H02 sensor connectors. See HEATED OXYGEN SENSORS (HO2S) (Page 6-31).

## REMOVE

1. See Figure 6-39. Remove exhaust shields (8,18, 21).
2. Remove cross-over pipe.

### NOTE

Slide exhaust flange down header pipe to improve clearance around exhaust port.

- a. Discard clamp (4).
- b. Remove flange bolt (5).
- c. Remove cross-over pipe (7).
- d. Discard gasket (24).
3. Remove exhaust header pipe.
  - a. Remove flange locknut (20).
  - b. Remove bracket (17).
  - c. Remove flange nuts (15).
  - d. Remove exhaust header pipe.
  - e. Discard gaskets (13).
4. Inspect retaining rings (14) and exhaust flanges (12). Replace if necessary.

## INSTALL

| FASTENER                               | TORQUE VALUE   |               |
|--|----------------|---------------|
| Exhaust bracket to transmission, screw | 100-120 in-lbs | 11.3-13.6 N-m |
| Exhaust cross-over bracket flange bolt | 14-18 ft-lbs   | 19-24.4 N-m   |
| Exhaust cross-over pipe clamp          | 38-43 ft-lbs   | 51.5-58.3 N-m |
| Exhaust flange nut, 1st torque         | 9-18 in-lbs    | 1-2 N-m       |

| FASTENER                              | TORQUE VALUE   |               |
|---------------------------------------|----------------|---------------|
| Exhaust flange nut, final torque      | 100-120 in-lbs | 11.3-13.6 N-m |
| Exhaust header bracket flange locknut | 15-20 ft-lbs   | 20.3-27.1 N-m |
| Exhaust shield clamps                 | 20-40 in-lbs   | 2.3-4.5 N-m   |

1. See Figure 6-39. If removed, install transmission exhaust bracket.
  - a. Install transmission exhaust bracket(10).
  - b. Tighten screws (9).  
Torque: 100-120 in-lbs (11.3-13.6 N-m) *Exhaust bracket to transmission, screw*

## 2. NOTE

Roll exhaust header pipe into position from front cylinder to rear cylinder.

Install exhaust header pipe.

- a. Install new gaskets (13) with tapered side out.
- b. Install exhaust header pipe.
- c. Install flange nuts (15) loosely.
- d. Install bracket (17).
- e. Install flange locknut (20). Do not tighten.
3. Install cross-over pipe.
  - a. Insert new clamp (4) onto cross-over pipe.
  - b. Install new gasket (24).
  - c. Install cross-over pipe (7). Do not tighten clamp (4).
4. Install cross-over support clamp.
  - a. Install cross-over support clamp (6).
  - b. Install flange bolt (5). Do not tighten.
5. Install mufflers. See MUFFLERS (Page 6-33).
6. Verify exhaust components have proper clearance to reduce noise and vibration.
7. Tighten exhaust flange nuts (15).
  - a. Tighten bottom nut to first torque.  
Torque: 9-18 in-lbs (1-2 N-m) *Exhaust flange nut, 1st torque*
  - b. Tighten top nut to final torque.  
Torque: 100-120 in-lbs (11.3-13.6 N-m) *Exhaust flange nut, final torque*





- c. Tighten bottom nut to final torque.  
Torque: 100-120 in-lbs (11.3-13.6 N-m) *Exhaust flange nut, final torque*

8. Tighten remaining exhaust system fasteners.

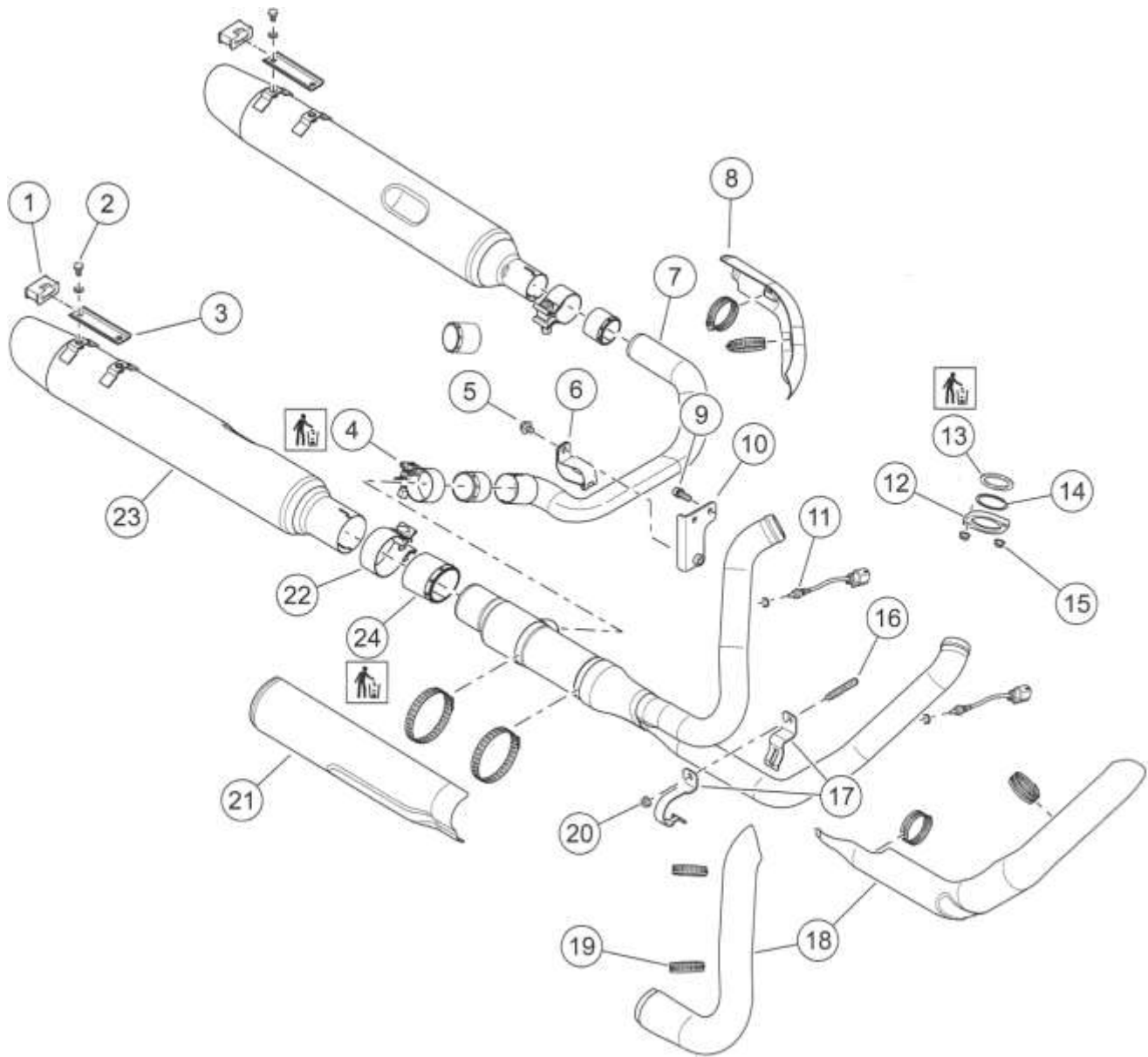
- a. Flange locknut (20). Tighten.  
Torque: 15-20 ft-lbs (20.3-27.1 N-m) *Exhaust header bracket flange locknut*
- b. Cross-over pipe clamp (4). Tighten.  
Torque: 38-43 ft-lbs (51.5-58.3 N-m) *Exhaust cross-over pipe clamp*
- c. Flange bolt (5). Tighten.  
Torque: 14-18 ft-lbs (19-24.4 N-m) *Exhaust cross-over bracket flange bolt*

9. *NOTE*

- *Verify exhaust shields are clear of motorcycle frame or any mounted components.*
- *Install cross-over pipe exhaust shield with the longer straight portion toward the muffler.*
- *Position each clamp so screw is positioned on outboard side and is accessible.*

Install exhaust shields. Tighten.

Torque: 20-40 in-lbs (2.3-4.5 N-m) *Exhaust shield clamps*



- |                                    |                                   |
|------------------------------------|-----------------------------------|
| 1. Rubber mount                    | 13. Gasket (2)                    |
| 2. Screw (4)                       | 14. Retaining ring (2)            |
| 3. Bracket (2)                     | 15. Flange nut (4)                |
| 4. Clamp                           | 16. Stud                          |
| 5. Flange bolt                     | 17. Exhaust side bracket          |
| 6. Crossover pipe support clamp    | 18. Exhaust shields, header pipes |
| 7. Crossover pipe                  | 19. Worm clamp (8)                |
| 8. Exhaust shield, crossover pipe  | 20. Flange locknut                |
| 9. Screw (2)                       | 21. Exhaust shield, collector     |
| 10. Transmission exhaust bracket   | 22. Muffler clamp (2)             |
| 11. O2 sensor (3) (select markets) | 23. Muffler (2)                   |
| 12. Exhaust flange (2)             | 24. Gasket (3) (select markets)   |

Figure 6-39. Exhaust System

**COMPLETE**

1. Connect HO2 sensor connectors. See HEATED OXYGEN SENSORS (HO2S) (Page 6-31).
2. Install right side rider foot board and brackets. See RIDER FOOTRESTS (Page 3-142).
3. Install seat. See SEAT (Page 3-148).
4. Install saddlebags. See SADDLEBAGS (Page 3-161).

## PREPARE

1. Remove seat. See SEAT (Page 3-148).
2. Detach top electrical caddy from frame for clearance. See TOP CADDY (Page 8-107).

## REMOVE

1. See Figure 6-40. Remove purge solenoid connector (1).
2. Remove purge lines from purge solenoid.
  - a. Remove solenoid-to-induction module purge line (3).
  - b. Remove canister-to-solenoid purge line (2).
3. Remove purge solenoid.

## INSTALL

1. See Figure 6-40. Install purge lines.
  - a. Install canister-to-solenoid purge line (2).
  - b. Install solenoid-to-induction module purge line (3).
2. Install purge solenoid connector (1).
3. Install purge solenoid.

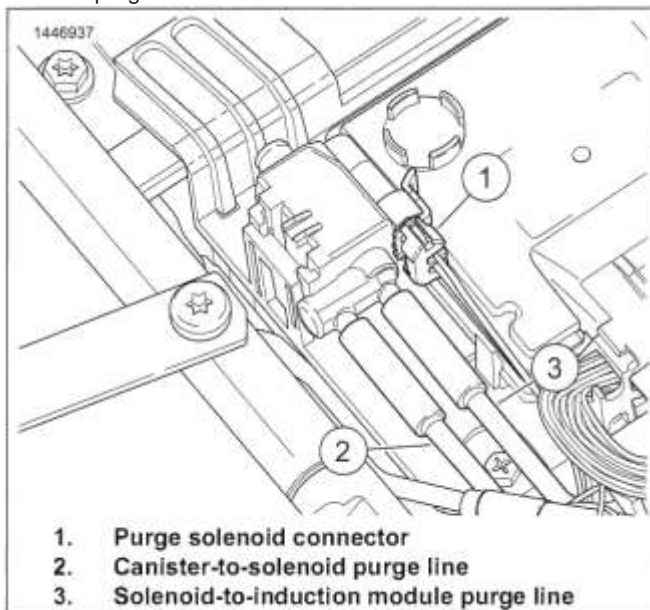


Figure 6-40. Purge Solenoid

## COMPLETE

1. Install top electrical caddy. See TOP CADDY (Page 8-107).
2. Install seat. See SEAT (Page 3-148).

## PREPARE

1. Remove seat. See SEAT (Page 3-148).
2. Remove saddlebags. See SADDLEBAGS (Page 3-161).
3. Remove side covers. See LEFT SIDE COVER (Page 3-62) and RIGHT SIDE COVER (Page 3-63).
4. Remove battery. See INSPECT BATTERY (Page 2-48).
5. Remove two screws securing battery hold-down bracket and ignition coil. See IGNITION COIL (Page 8-20).

## REMOVE

1. See Figure 6-41. Remove vent lines.
  - a. Disconnect purge line (2) from canister fitting marked "PURGE."
  - b. Disconnect fuel vent line (1) from canister fitting marked "TANK."
2. See Figure 6-42. Remove ground ring terminals.
  - a. Remove three ring terminals from left ground stud (1).
  - b. Remove two ring terminals from right ground stud (2).
3. Remove charcoal canister.
  - a. Remove two screws to release canister from frame cross member.
  - b. Remove canister from cross member.

## INSTALL

- a. Install canister with two screws. Tighten.

| FASTENER          | TORQUE VALUE |             |
|-------------------|--------------|-------------|
| Charcoal canister | 15-20 in-lbs | 1.7-2.3 N-m |

1. Install charcoal canister.
 

Torque: 15-20 in-lbs (1.7-2.3 N-m) *Charcoal canister*
2. See Figure 6-42. Install ring terminals.
  - a. Install three ring terminals on the left ground stud (1).
  - b. Install two ring terminals on right ground stud (2). Place battery chassis ground terminal on stud first.

3. See Figure 6-41. Connect lines.
  - a. Connect fuel vapor vent line (1) to upper fitting marked "TANK."
  - b. Connect purge line (2) to lower fitting marked "PURGE."

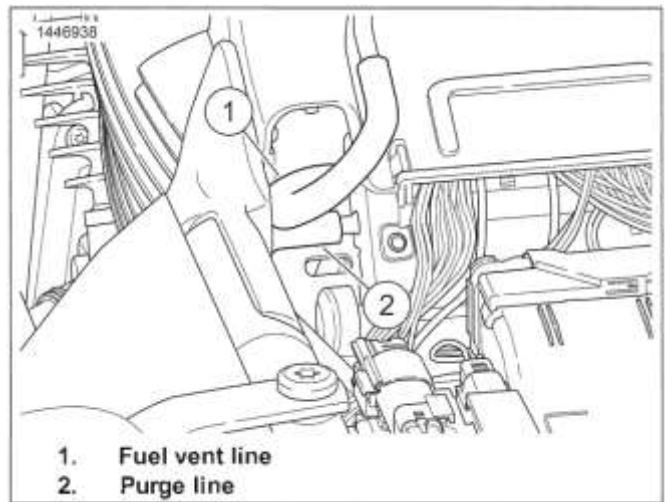


Figure 6-41. Purge Line Connections

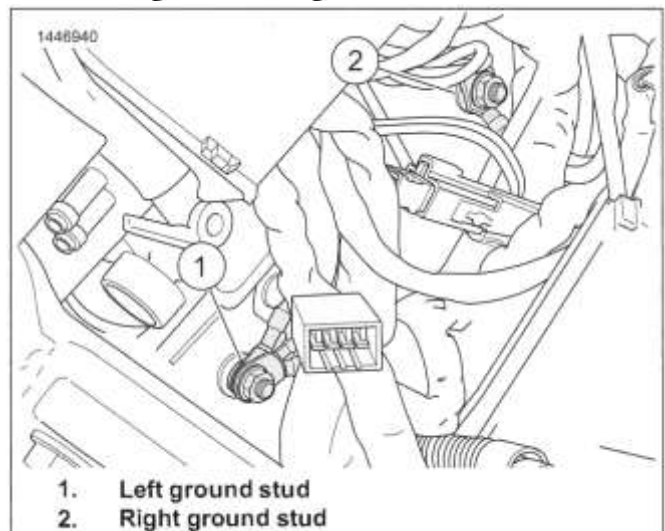


Figure 6-42. Chassis Ground Studs

## COMPLETE

1. Install left electrical caddy screws. See LEFT SIDE CADDY (Page 8-108).
2. Install two screws securing battery hold-down bracket and ignition coil. See IGNITION COIL (Page 8-20).
3. Install battery. See INSPECT BATTERY (Page 2-48).
4. Install side covers. See LEFT SIDE COVER (Page 3-62) and RIGHT SIDE COVER (Page 3-63).
5. Install saddlebags. See SADDLEBAGS (Page 3-161).
6. Install seat. See SEAT (Page 3-148).

**PREPARE**

1. Remove seat. See SEAT (Page 3-148).
2. **Fuel vent line:**
  - a. Remove left saddlebag. See SADDLEBAGS (Page 3-161).
  - b. Remove left side cover. See LEFT SIDE COVER (Page 3-62).
  - c. Remove main fuse. See POWER DISCONNECT (Page 8-8).
  - d. Remove console. See CONSOLE (Page 6-5).
3. **Solenoid-to-induction module line:**
  - a. Purge fuel line. See PURGE FUEL LINE (Page 6-7).
  - b. Remove left saddlebag. See SADDLEBAGS (Page 3-161).
  - c. Remove left side cover. See LEFT SIDE COVER (Page 3-62).
  - d. Remove main fuse. See POWER DISCONNECT (Page 8-8).
  - e. Remove console. See FUEL TANK (Page 6-10).
  - f. Remove fuel tank. See CONSOLE (Page 6-5).

**REMOVE**

1. See Figure 6-43. Remove fuel vent line.
  - a. Detach fuel vent line (6) from valve on fuel tank top plate (7).
  - b. Detach fuel vent line (6) from charcoal canister (9).
  - c. Remove fuel vent line (6).
2. See Figure 6-44. Remove canister-to-solenoid line.
  - a. Detach canister-to-solenoid line (3) from charcoal canister.
  - b. See Figure 6-43. Detach canister-to-solenoid line (4) from purge solenoid (2).
  - c. Remove canister-to-solenoid line (4).
3. See Figure 6-44. Remove solenoid-to-induction module line.
  - a. Detach solenoid-to-induction module line (4) from purge solenoid (2).
  - b. Detach solenoid-to-induction module line (4) from retainer (6).

- c. Discard retainer (6).
- d. See Figure 6-43. Detach solenoid-to-induction module line (3) from induction module.
- e. Remove solenoid-to-induction module line (3).

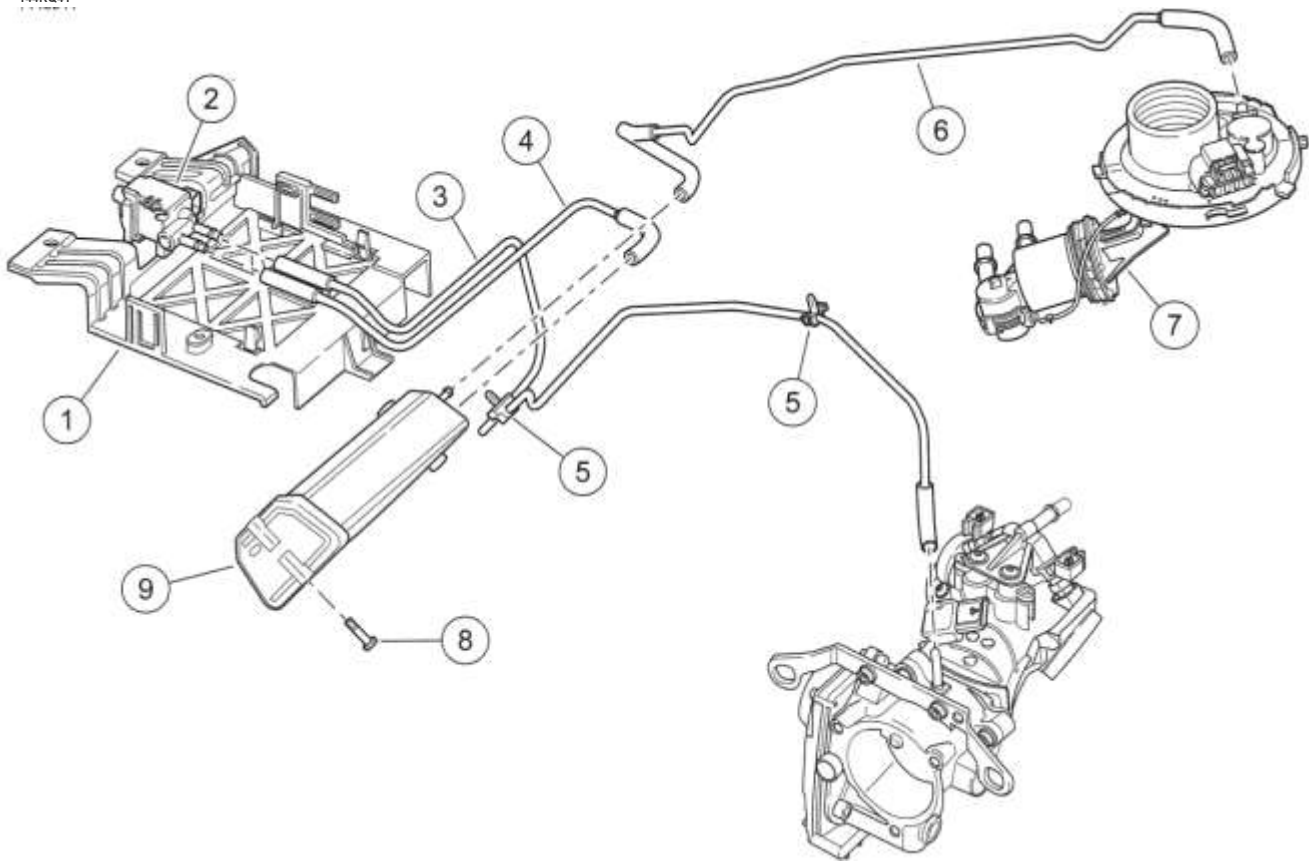
**INSTALL**

1. Install fuel vapor vent line.
  - a. See Figure 6-43. Place fuel vapor vent line (6) in approximate position.
  - b. Attach fuel vapor vent line (6) to charcoal canister (9).
  - c. Attach fuel vapor vent line (6) to vapor valve on fuel tank top plate (7).
2. Install canister-to-solenoid line.
  - a. See Figure 6-44. Place canister-to-solenoid line (3) in approximate position.
  - b. See Figure 6-43. Attach canister-to-solenoid line (4) to charcoal canister (9).
  - c. Attach canister-to-solenoid line (4) to purge solenoid (2).
3. See Figure 6-44. Install solenoid-to-induction module line.

**NOTE**

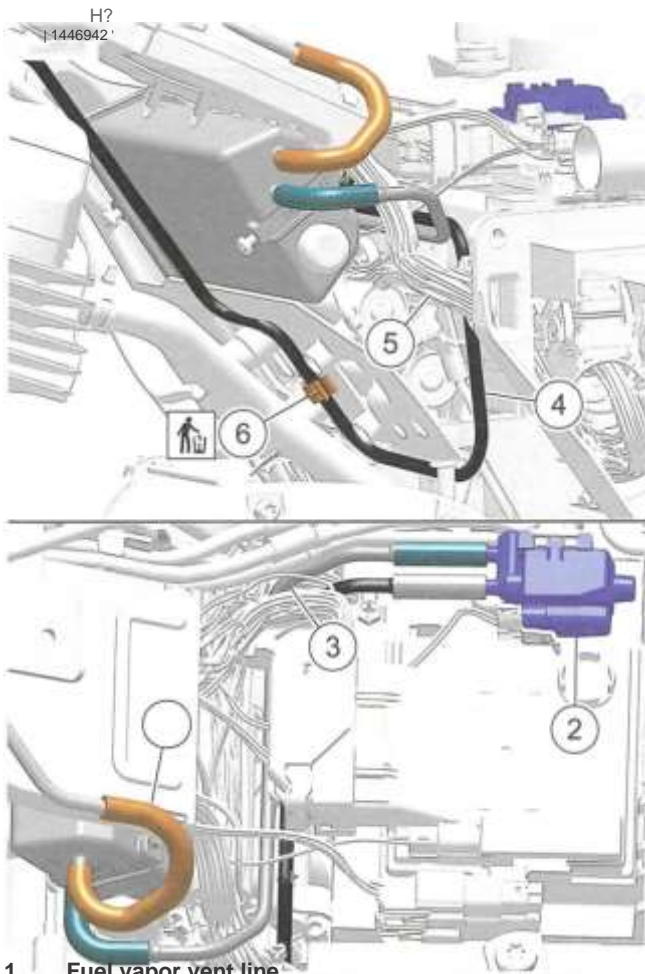
*solenoid-to-induction module line (4) must be routed under main wire harness (5), then up to purge solenoid (2).*

- a. Place solenoid-to-induction module line (4) in approximate position.
- b. See Figure 6-43. Attach solenoid-to-induction module line (3) to induction module.
- c. Attach solenoid-to-induction module line (3) to upper fitting of purge solenoid (2).
- d. Figure 6-44 Install **new** retainer (6).
- e. Attach solenoid-to-induction module line (4) to retainer (6).



- |                                      |                        |
|--------------------------------------|------------------------|
| 1. Top caddy                         | 6. Fuel vent line      |
| 2. Purge solenoid                    | 7. Fuel tank top plate |
| 3. Solenoid-to-induction module line | 8. Fastener (2)        |
| 4. Canister-to solenoid line         | 9. Charcoal canister   |
| 5. Retainer (2)                      |                        |

Figure 6-43. Evaporative Emissions Control System (EVAP)



1. Fuel vapor vent line
2. Purge solenoid
3. Canister-to-solenoid line
4. Solenoid-to-induction module line
5. Main wire harness
6. Retainer (2)

Figure 6-44. Purge Tube Connections and Routing

## **COMPLETE**

1. **Solenoid-to-induction module line:**
  - a. Install fuel tank. See FUEL TANK (Page 6-10).
  - b. Install console. See CONSOLE (Page 6-5).
  - c. Install main fuse. See POWER DISCONNECT (Page 8-8).
  - d. Install left side cover. See LEFT SIDE COVER (Page 3-62).
  - e. Install left saddlebag. See SADDLEBAGS (Page 3-161).
2. **Fuel vapor vent line.**
  - a. Install console. See CONSOLE (Page 6-5).
  - b. Install main fuse. See POWER DISCONNECT (Page 8-8).
  - c. Install left side cover. See LEFT SIDE COVER (Page 3-62).
  - d. Install left saddlebag. See SADDLEBAGS (Page 3-161).
3. Install seat. See SEAT (Page 3-148).





# NOTES

| <b>SUBJECT</b>                                   | <b>PAGE NO.</b> |
|--|-----------------|
| 7.1 FASTENER TORQUE VALUES .....                 | 7-1             |
| 7.2 SPECIFICATIONS .....                         | 7-2             |
| 7.3 COOLANT FLOW .....                           | 7-3             |
| 7.4 DIAGNOSE AND TEST .....                      | 7-5             |
| 7.5 COOLANT.....                                 | 7-8             |
| 7.6 COOLANT PUMP .....                           | 7-11            |
| 7.7 COOLANT OVERFLOW TANK.....                   | 7-12            |
| 7.8 COOLANT HOSES .....                          | 7-13            |
| 7.9 ENGINE COOLANT TEMPERATURE (ECT) SENSOR..... | 7-17            |
| 7.10 RADIATOR.....                               | 7-18            |

## NOTES



**FASTENER TORQUE VALUES IN THIS CHAPTER \_\_\_\_\_**

| FASTENER                      | TORQUE VALUE     |               | NOTES  |
|-------------------------------|------------------|---------------|--|
| Coolant downtube lower screws | 240-264 in-lbs   | 27.1-29.8 N-m | 7.8 COOLANT HOSES, Remove and Install: Coolant Downtubes |
| Coolant downtube upper screws | 90-120 in-lbs    | 10.2-13.6 N-m | 7.8 COOLANT HOSES, Remove and Install: Coolant Downtubes |
| Coolant line manifold screws  | 90-120 in-lbs    | 10.2-13.6 N-m | 7.8 COOLANT HOSES, Remove and Install: Coolant Lines     |
| Coolant overflow tank nut     | 65-74 in-lbs     | 7.3-8.4 N-m   | 7.7 COOLANT OVERFLOW TANK, Install                       |
| Temperature sensor, radiator  | 17.7-19.2 ft-lbs | 24-26 N-m     | 7.9 ENGINE COOLANT TEMPERATURE (ECT) SENSOR, Install     |

**GENERAL**

**Table 7-1. Capacities**

| ITEM                       | QUARTS | LITERS |
|----------------------------|--------|--------|
| Engine coolant *           | 0.8    | 0.8    |
| * Excludes overflow bottle |        |        |

**Table 7-2. Coolant Pressure**

| ITEM               | PSI | KPA |
|--------------------|-----|-----|
| Cap lower limit    | 18  | 124 |
| Rated cap pressure | 20  | 138 |
| Cap upper limit    | 22  | 152 |

**Table 7-3. Coolant Temperatures**

| ITEM                    | °F  | °C    |
|-------------------------|-----|-------|
| Engine temperature lamp | 266 | 130   |
| Antifreeze protection   | -34 | -36.7 |

**Table 7-4. Fan Operation \***

| STATUS  | Coolant Temperature |     |
|---|---------------------|-----|
|   | °F                  | °C  |
| On (below 15 mph)   | 194                 | 90  |
| Off (below 15 mph)  | 181                 | 83  |
| On (above 15 mph)   | 230                 | 110 |
| Off (above 15 mph)  | 216                 | 102 |
| Fans and pump will run after vehicle shutdown until 189 °F (87 °C) is reached or three minutes, whichever occurs first. |                     |     |

## OPERATION

---

### OPERATION

#### Electric Pump

- See Figure 7-1. Electric pump (4) is located under the voltage regulator.
- Circulates coolant.
- Will not run until engine is running, then runs continually while engine is running.

#### Electric Fans

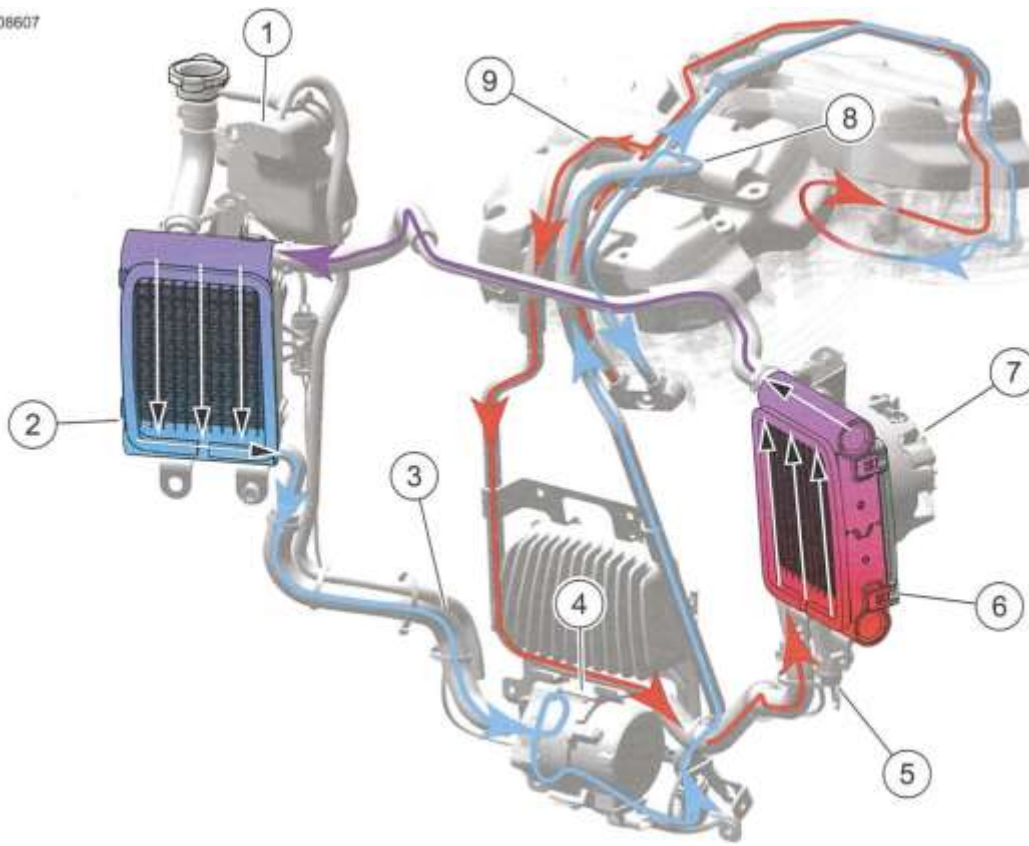
- See Figure 7-1. Fans (7) are mounted behind left and right radiators.
  - Boosts air flow at low road speeds and at engine idle.
  - Controlled by ECM.
- Cycle on and off while engine is running, depending on vehicle speed and coolant temperature.
- If fans are running when engine is stopped:
  - The Fans and electric pump will continue to run until coolant is at a certain temperature or for a predetermined length of time, whichever occurs first.
- If fans are not running when engine is stopped:
  - Fans will not start again with ignition OFF.

#### Temperature Switch

- See Figure 7-1. Temperature switch (5) is located under the left radiator (6).
- Reports coolant temperatures to ECM.

### COOLANT FLOW

1. Pump (4) to inlet manifold (8).
2. Inlet manifold (8) to cylinder head.
3. Cylinder head to outlet manifold (9).
4. Outlet manifold (9) to left radiator (6).
5. Left radiator (6) to right radiator (2).
6. Right radiator (2) through coolant return hose (3) to electric pump (4).
7. Coolant overflow tank (1):
  - a. Stores extra coolant to control coolant expansion and contraction during operation.



- |                                 |                    |
|---------------------------------|--------------------|
| 1. Coolant overflow tank        | 6. Left radiator   |
| 2. Right radiator               | 7. Fan (2)         |
| 3. Hose, coolant return to pump | 8. Inlet manifold  |
| 4. Electric pump                | 9. Outlet manifold |
| 5. Coolant temperature switch   |                    |

Figure 7-1. Coolant Flow



**TROUBLESHOOTING**

**TROUBLESHOOTING**

**A WARNING**

The Troubleshooting section of this manual is a guide to diagnose problems. Read the appropriate sections of this manual before performing any work. Improper repair and/or maintenance could result in death or serious injury. (00528b)

**High Engine Temperature**

- Blocked hoses, pipes or passages
- Restricted air flow through radiator
- Defective cooling fan
- Faulty coolant pump
- Low coolant level
- Air in system
- Defective pressure cap
- Defective engine coolant sensor

**Coolant Leaks**

- Pressure cap not properly installed
- Damaged pressure cap gasket
- Deteriorated O-rings on coolant pump or manifolds
- Leaking hose or hose connection

**PRESSURE CAP TEST**

**PRESSURE CAP TEST**

| PART NUMBER | TOOLNAME                       |
|-------------|--------------------------------|
| HD-45335    | COOLANT SYSTEM PRESSURE TESTER |

Test pressure cap for the correct operating range every time the coolant is changed or any cooling system maintenance performed.

**A WARNING**

**Do not loosen or remove pressure cap when cooling system is hot. The cooling system is under pressure and hot coolant and steam can escape from pressure cap, which could cause severe burns. Allow motorcycle to cool before servicing the cooling system. (00091c)**

1. Remove pressure cap.
2. Inspect cap for gasket deterioration and inoperative springs.
3. **New cap:** Wet the upper sealing gasket before turning onto adapter.
4. See Figure 7-2. Connect tester to pressure cap.

Special Tool: COOLANT SYSTEM PRESSURE TESTER (HD-45335)

5. Pump handle to pressurize cap. Stop pumping when pressure limiting valve in cap opens.
6. Replace pressure cap if:
  - a. Opens below low limit, 18 psi (124 kPa).
  - b. Opens above high limit, 22 psi (152 kPa).
  - c. Pressure falls rapidly when pressurized within range.
7. Remove adapter and cap.

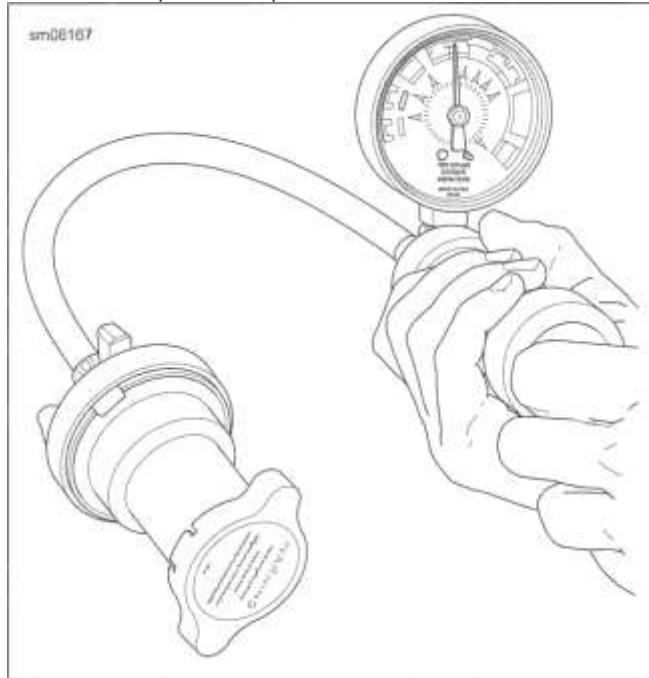


Figure 7-2. Pressure Cap Test

**SYSTEM PRESSURE TEST**

**SYSTEM PRESSURE TEST**

| PART NUMBER | TOOLNAME                       |
|-------------|--------------------------------|
| HD-45335    | COOLANT SYSTEM PRESSURE TESTER |

1. See Figure 7-3. Before troubleshooting cooling system, make sure that engine coolant level is at or slightly above COLD full mark on coolant overflow tank (3).

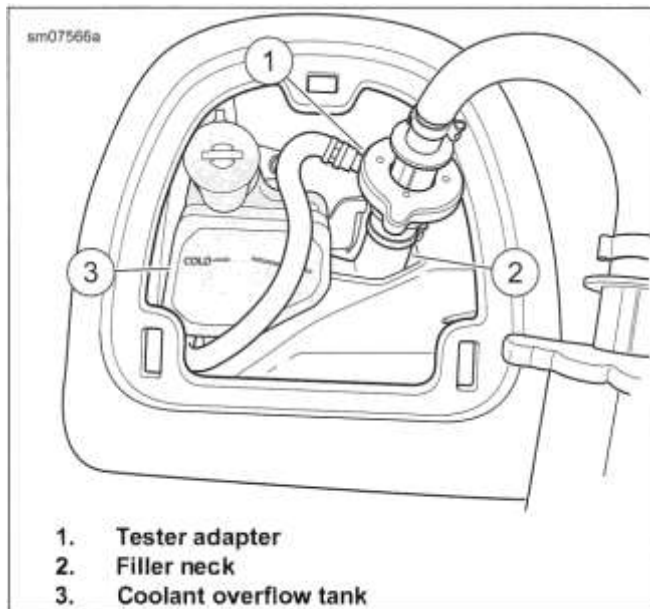
**A WARNING**

**Do not loosen or remove pressure cap when cooling system is hot. The cooling system is under pressure and hot coolant and steam can escape from pressure cap, which could cause severe burns. Allow motorcycle to cool before servicing the cooling system. (00091c)**

2. Pull filler neck (2) from retainer on coolant overflow tank (3). Remove cap.

**NOTE**

Damaged filler neck cams, safety stops and sealing surfaces



**Figure 7-3. System Pressure Test**

**Table 7-5. System Pressure Test**

| NEEDLE MOVEMENT            | LEAK  | ACTION                    |
|----------------------------|-------|---------------------------|
| Holds steady for 2 minutes | None  | None                      |
| Drops slowly               | Small | Perform dye test          |
| Drops quickly              | Major | Perform visual inspection |

can cause cap to leak or affect the pressure limiting valve. Replace filler neck if damaged. Damaged cap stop can also cause a coolant leak. Replace cap if damaged.

- Clean and inspect filler neck (2), upper and lower sealing seats, overflow tube and coolant overflow tank (3).

**NOTE**

Wet upper sealing surfaces before turning adapter onto tester head.

- Connect tester to filler neck.  
Special Tool: COOLANT SYSTEM PRESSURE TESTER (HD-45335)

**NOTE**

When performing the coolant system pressure test, never exceed the upper limit rating of the pressure cap. Excessive pressure can rupture cooling pipes and radiator.

- Pump tester until pressure reaches 20 psi (138 kPa).
- Observe pressure gauge and proceed as indicated in Table 7-5.
- Release system pressure. Remove tester from filler neck (2).

**FREEZE POINT TEST**

**FREEZE POINT TEST**

- Allow engine to cool.
- Remove pressure cap.
- Place a few drops of coolant from filler neck onto prism of either one of the following testers.

Special Tool: BATTERY TESTER (HD-23688)

Special Tool: BATTERY TESTER (HD-26568)

| PART NUMBER | TOOL NAME                              |
|-------------|--|
| HD-29545-6A | COOLANT FLUORESCENT LEAK DETECTION DYE |
| HD-35457    | BLACK LIGHT LEAK DETECTOR              |

- Hold prism up to a light.
- Coolant freeze point is the mark where the dark area begins on the ETHYLENE GLYCOL temperature scale.
- Compare freeze point of coolant to anticipated operating or storage temperatures. Replace as required. See COOLANT (Page 7-8).
  - If indicated freeze point is less than specified on the container, replace with antifreeze.

GENUINE HARLEY-DAVIDSON EXTENDED LIFE ANTIFREEZE (99822-02)

- b. If anticipated cold temperatures exceed that of Harley-Davidson premixed antifreeze, replace with a mixture of de-ionized water and ethylene glycol antifreeze. Follow directions on the container to create a mixture with a freeze point that will exceed the expected cold temperature.
7. Install pressure cap.

## **LEAK DETECTION DYE TEST** \_\_\_\_\_

### **LEAK DETECTION DYE TEST**

1. Before troubleshooting cooling system, make sure that engine coolant level is at COLD FULL mark on coolant overflow tank.

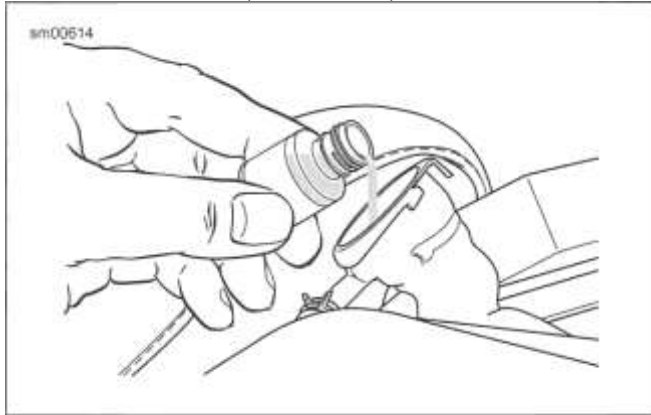
#### *NOTE*

*If coolant overflow tank is empty when engine is cold, air has possibly been drawn into coolant system. Fill system with coolant and purge any trapped air.*

**Do not loosen or remove pressure cap when cooling system is hot. The cooling system is under pressure and hot coolant and steam can escape from pressure cap, which could cause severe burns. Allow motorcycle to cool before servicing the cooling system. (00091c)**

2. Remove filler cap.
3. If filler neck is full of coolant, remove an amount of coolant equal to the amount of dye.
4. See Figure 7-4. Pour dye into filler neck.

Special Tool: COOLANT FLUORESCENT LEAK DETECTION DYE (HD-29545-6A)



**Figure 7-4. Pouring Dye into Filler Neck**

5. Install pressure cap. Run engine for 10 minutes.
6. Use detector to illuminate entire cooling system. A yellow fluorescence indicates a leak.  
Special Tool: BLACK LIGHT LEAK DETECTOR (HD-35457)
7. Inspect engine oil for yellow dye.

**NOTE**

*Dye in the oil may indicate a damaged engine head gasket. Draining and replacing coolant contaminated oil is necessary as part of engine service.*

**GASKET LEAK TEST**

| PART NUMBER | TOOLNAME                       |
|-------------|--------------------------------|
| HD-45335    | COOLANT SYSTEM PRESSURE TESTER |

**GASKET LEAK TEST**

Perform the following tests if a leak exists but no external evidence of a leak is found.

1. Start and run cold engine.
  - a. White smoke from exhaust system indicates a leaking gasket.
2. Run engine. Turn off engine.
  - a. Remove oil level dipstick. Light-colored foam on dipstick indicates a leaking gasket.
  - b. Open oil drain plug. Drain a small amount of oil. Water or coolant drains out first if gasket is leaking.

**NOTE**

- Do not allow pressure to build up past maximum for system. If pressure rises past maximum, turn off engine and turn butterfly pressure valve perpendicular to tester head to release pressure.
- Do not continue to run engine unattended with COOLANT SYSTEM PRESSURE TESTER (PART NUMBER: HD-45335) installed. There is no safety valve with the pressure cap removed and the COOLANT SYSTEM PRESSURE TESTER (PART NUMBER: HD-45335) installed.

3. Install tester.

Special Tool: COOLANT SYSTEM PRESSURE TESTER (HD-45335)

**A WARNING**

**Disconnecting spark plug cable with engine running can result in electric shock and death or serious injury. (00464b)**

4. Start cold engine and idle engine to normal operating temperature.
  - a. If gauge indicates fast pressure buildup, a gasket is leaking.
  - b. If pressure does not build up immediately, pump the tester to 20 psi (138 kPa).
  - c. A vibrating needle indicates a leaking cylinder head gasket.
  - d. Turn off engine. Disable one spark plug at the coil. Start engine. Repeat for other cylinder. The needle stops vibrating when spark is removed from leaking cylinder.

**NOTE**

*Always replace engine oil after replacing cylinder head gasket.*

## CHECK COOLANT LEVEL

At operating temperature, radiators and oil coolers contain

| PART NUMBER | CONSUMABLE  |
|-------------|---|
| 99822-02    | GENUINE HARLEY-DAVIDSON<br>EXTENDED LIFE ANTIFREEZE |

### A CAUTION

hot fluids. Contact with a radiator or oil cooler can result in minor or moderate burns. (00141b)

1. Check motorcycle on level ground.
2. Remove access panel from lower right fairing. See FAIRING LOWERS (Page 3-113).

### NOTE

See Figure 7-5. Coolant overflow tank has two lines. Use the angled fill line (2) when motorcycle is leaning on jiffy stand.

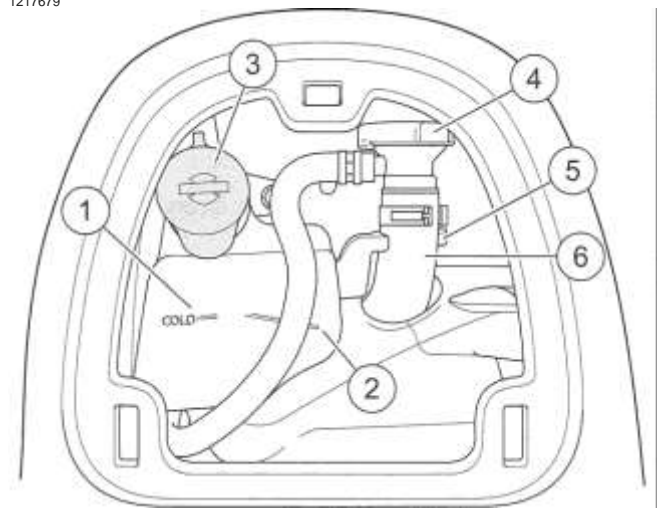
3. Check coolant level.
  - a. Check that coolant overflow tank is at or slightly above the COLD full line (1).

### NOTE

- Do not remove pressure cap (4). Fill coolant overflow tank by removing overflow cap (3).
- If coolant overflow tank is empty when engine is cold, inspect system for leaks, repair as needed. Fill system with coolant and perform bleed procedure. See Drain and Fill Cooling System (Page 7-8).

4. If level is below COLD line, add coolant.
  - a. Remove overflow tank cap (3).
  - b. Add coolant until fluid level reaches COLD line (1).  
GENUINE HARLEY-DAVIDSON EXTENDED LIFE ANTIFREEZE (99822-02)
  - c. Install overflow tank cap (3).
5. Install access panel.

1217679



1. Cold full line, vehicle upright
2. Cold full line, vehicle on jiffy stand
3. Overflow tank cap
4. Pressure cap
5. Bracket
6. Filler neck

Figure 7-5. Coolant Level

## DRAIN AND FILL COOLING SYSTEM

| PART NUMBER | TOOL NAME                                    |
|-------------|--|
| HD-52004    | 24 INCH HOSE CLAMP TOOL                      |
| MCR102A     | MATCO VACUUM VENTURI COOLING SYSTEM REFILLER |
| MPT10128    | COOLING SYSTEM ADAPTER                       |

### A WARNING

Do not loosen or remove pressure cap when cooling system is hot. The cooling system is under pressure and hot coolant and steam can escape from pressure cap, which could cause severe burns. Allow motorcycle to cool before servicing the cooling system. (00091c)

### Drain System

#### NOTE

Use 24 INCH HOSE CLAMP TOOL (PART NUMBER: HD-52004) to reach rotated or difficult to reach spring clamps.

1. Remove main fuse. See POWER DISCONNECT (Page 8-8).
2. Remove access panel from right lower fairing. See FAIRING LOWERS (Page 3-113).

#### NOTE

See Figure 7-5. Do not remove pressure cap (4).

3. Remove overflow tank cap (3).
4. Remove pump cover. See COOLANT PUMP (Page 7-11).

#### NOTE

Hose barb on the pump is fragile. Use caution when removing coolant hose.

5. See Figure 7-6. Disconnect hoses (1,2) from pump.

6. Disconnect hose (3) from right coolant downtube. Lower hose to drain.

7. Drain and discard used coolant.

**NOTE**

Verify that the hose clamp is installed between the raised barb and pump body. Do not install the clamp directly over the raised area.

8. Connect hose (1, 2) to pump.

a. Install spring clamps.

b. Verify that hoses are installed completely with the hose end touching the pump housing

9. Connect hose (3) to right coolant downtube. Secure with spring clamp.

10. Install pump cover. See COOLANT PUMP (Page 7-11).

11. Install main fuse. See POWER DISCONNECT (Page 8-8).

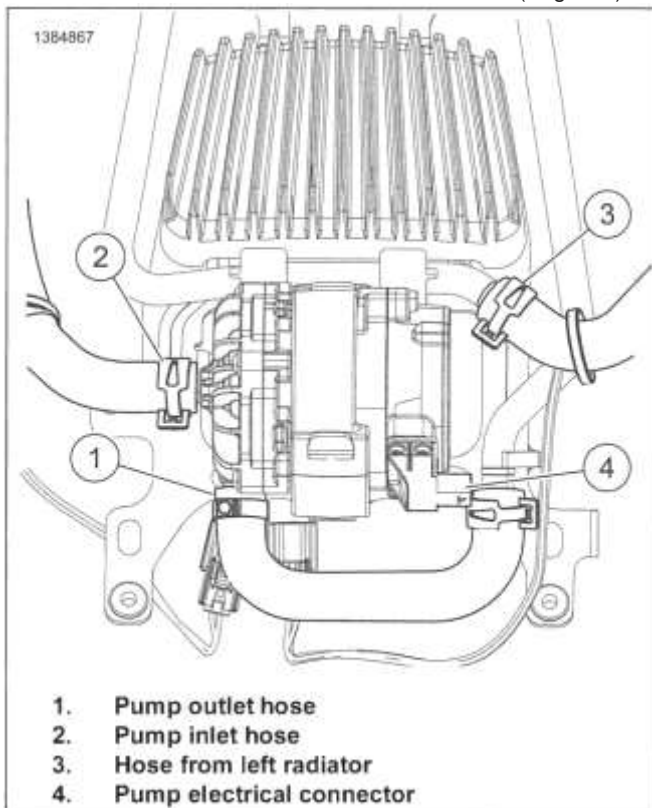


Figure 7-6. Drain Cooling System

## Power Fill and Bleed

**NOTICE**

Use only Genuine Harley-Davidson Extended Life Antifreeze and Coolant. Use of other coolants/mixtures may lead to motorcycle damage. (00179c)

**NOTE**

See Figure 7-7. Harley-Davidson recommends using MATCO VACUUM VENTURI COOLING SYSTEM REFILLER (PART NUMBER: MCR102A) along with COOLING SYSTEM ADAPTER (PART NUMBER: MPT10128) or equivalent. This allows for a vacuum test of the complete system and effective filling with coolant.

Follow the manufacturer's instructions supplied with the tool. A general overview follows. **7.5**

1. Stand motorcycle upright (not leaning on jiffy stand).

2. See Figure 7-5. Remove pressure cap (4).

3. Attach vacuum filler tool.

4. Connect to low-pressure, compressed air.

5. Immerse coolant pick-up hose into **new** coolant mixture. Fill hose and tool with coolant to purge air.

6. Turn on air valve and observe vacuum gauge. When gauge has stabilized, turn off air valve.

7. Observe vacuum gauge to verify that it remains steady.

8. Open coolant valve to allow system to fill.

9. Remove vacuum filler tool.

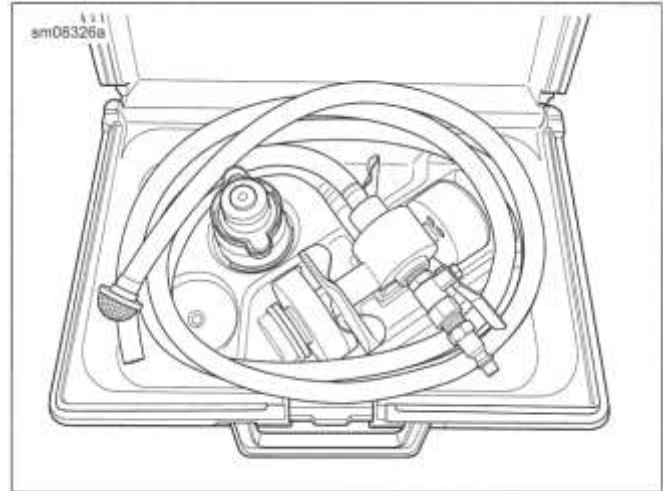


Figure 7-7. Mateo Vacuum Venturi Cooling System Refiller

**NOTE**

See Figure 7-8. Verify that pressure cap is completely tightened. Tab (1) must contact stop (2) for proper system operation.

10. Install pressure cap (4).

11. Fill coolant overflow tank to the cold fill line. Install overflow tank cap.

12. Start engine and check for leaks when hot.

**NOTE**

Coolant level in the coolant overflow tank typically rises slightly when the engine is at operating temperature. The level returns to the COLD line when the system has cooled down.

13. Verify level in coolant overflow tank after system has cooled.

14. Secure filler neck (6) to bracket (5).

15. Install access panel. See FAIRING LOWERS (Page 3-113).

## Manual Fill and Bleed

**NOTICE**

Use only Genuine Harley-Davidson Extended Life Antifreeze and Coolant. Use of other coolants/mixtures may lead to motorcycle damage. (00179c)

1. Park motorcycle.
  - a. **2-wheel:** Lean on jiffy stand.
  - b. **Trike:** Raise front and right rear wheels about 6 in (152 mm).
2. See Figure 7-8. Remove pressure cap.

**NOTE**

- System capacity is approximately 0.8 qt (0.8 L).
  - Use a squeeze bottle similar to a dishwashing liquid bottle to simplify the procedure.
  - A complete filling and bleeding will take 10-15 minutes.
3. Fill system through filler neck until coolant is visible. Allow coolant to bleed down for a few seconds and repeat.
  4. Bleed cooling system:
    - a. Turn ignition switch ON. Turn run switch ON. Do not start engine.
    - b. Turn throttle to greater than 50% and hold for at least 3 seconds. Coolant pump and fans start. Release throttle.
    - c. As the pump runs, continue to add coolant until filler neck remains topped off. Turn throttle full open until pump and fans stop.
    - d. Wait 10-15 seconds and repeat above two steps until no more coolant can be added.

**NOTE**

*The pump and fans run indefinitely in bleed mode until ignition is turned OFF or the throttle is held full open, unlike operational mode.*

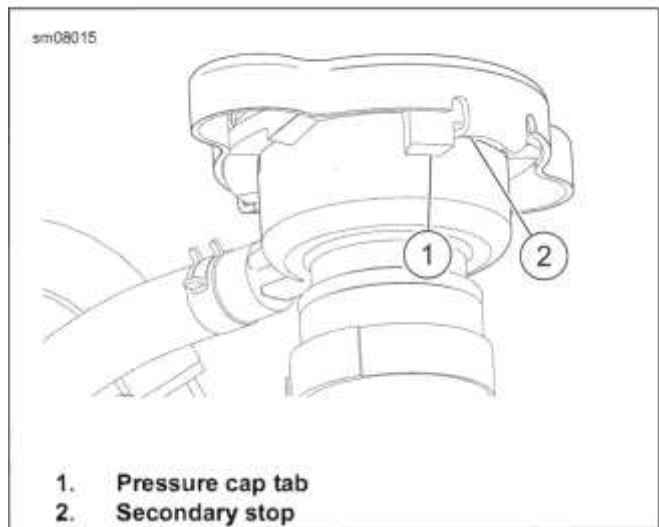
- e. Turn ignition switch OFF. Pump and fans stop.

**NOTE**

*See Figure 7-8. Verify that pressure cap is completely tightened. Tab (1) must contact secondary stop (2) for proper system operation.*

5. Install pressure cap.
6. Fill coolant overflow tank to the COLD full line. Install overflow tank cap.
7. Start engine and check for leaks when hot.
8. Verify level in coolant overflow tank after system has cooled.
9. Secure filler neck (6) to bracket (5).

10. Install access panel. See FAIRING LOWERES (Page 3-113).



**Figure 7-8. Pressure Cap Installation**

## PREPARE

1. Remove main fuse. See POWER DISCONNECT (Page 8-8).
2. Drain coolant. See INSPECT RADIATOR AND COOLANT (Page 2-34).

## REMOVE

1. See Figure 7-9. Disconnect pump connector (6).
2. Remove inlet hose.
  - a. Remove spring clamp (1).
  - b. Remove inlet hose (2).
3. Remove outlet hose.
  - a. Remove crimp clamp (3). See CRIMP CLAMPS (Page 4-16).
  - b. Remove outlet hose (4).
4. Remove pump from tabs (5).

## INSTALL

1. See Figure 7-9. Install coolant pump on tabs (5).
2. Install outlet hose.
  - a. Install outlet hose (4).
  - b. Install crimp clamp (3). See CRIMP CLAMPS (Page 4-16).
3. Install inlet hose.
  - a. Install inlet hose (2).
  - b. Install spring clamp (1).

4. Connect pump connector (6).

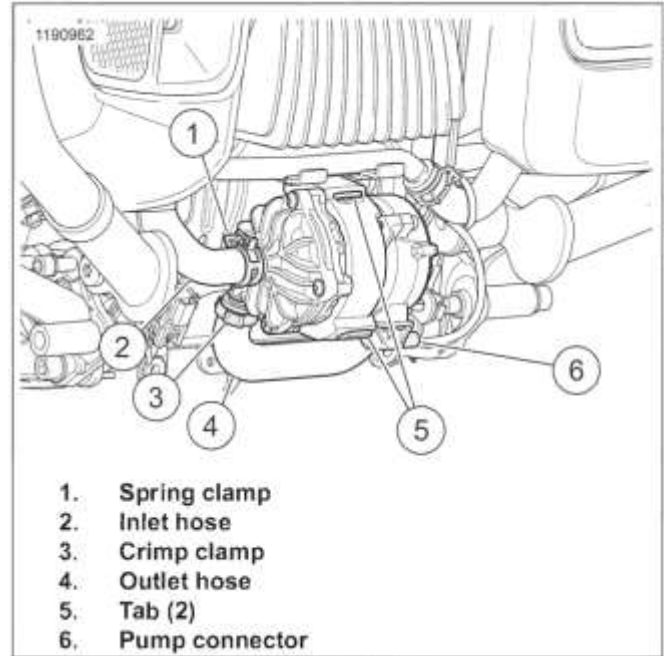


Figure 7-9. Coolant Pump

## COMPLETE

1. Fill cooling system. See INSPECT RADIATOR AND COOLANT (Page 2-34).
2. Install main fuse. See POWER DISCONNECT (Page 8-8).



# COOLANT PUMP PREPARE

7.6

1. Remove access panel. See FAIRING LOWERS (Page 3-113).

## REMOVE

1. See Figure 7-10. Disconnect coolant overflow hose.
  - a. Detach clamp (2).
  - b. Detach overflow hose (3).
2. Remove coolant overflow tank.
  - a. Remove nut (1).
  - b. Pull coolant overflow tank out enough to access vent hose (4).
  - c. Detach vent hose (4).
  - d. Remove coolant overflow tank.
  - e. Empty coolant overflow tank, if necessary.
  - f. Remove overflow hose (3), if necessary.

## INSTALL

1. See Figure 7-10. Install overflow hose (3) on coolant

| FASTENER                  | TORQUE VALUE |             |
|---------------------------|--------------|-------------|
| Coolant overflow tank nut | 65-74 in-lbs | 7.3-8.4 N-m |

| PART NUMBER | CONSUMABLE                        |
|-------------|-----------------------------------|
| 99653-85    | HYLOMAR GASKET AND THREAD SEALANT |

overflow tank, if removed.

- a. Clean hose barb. Clean inside of overflow hose end.
- b. Apply small amount of sealant. to hose barb. Apply sealant completely around flare of barb using an applicator. Do not get sealant in opening of barb.

HYLOMAR GASKET AND THREAD SEALANT  
(99653-85)

- c. Attach overflow hose (3) to bottom of coolant overflow tank.
  - d. Attach clamp.
2. Install coolant overflow tank.
    - a. Attach vent hose (4).
    - b. Install coolant overflow tank.
    - c. Install nut (1 ). Tighten.  
Torque: 65-74 in-lbs (7.3-8.4 N-m) *Coolant overflow tank nut*
    - d. Attach overflow hose (3).
    - e. Attach clamp (2).

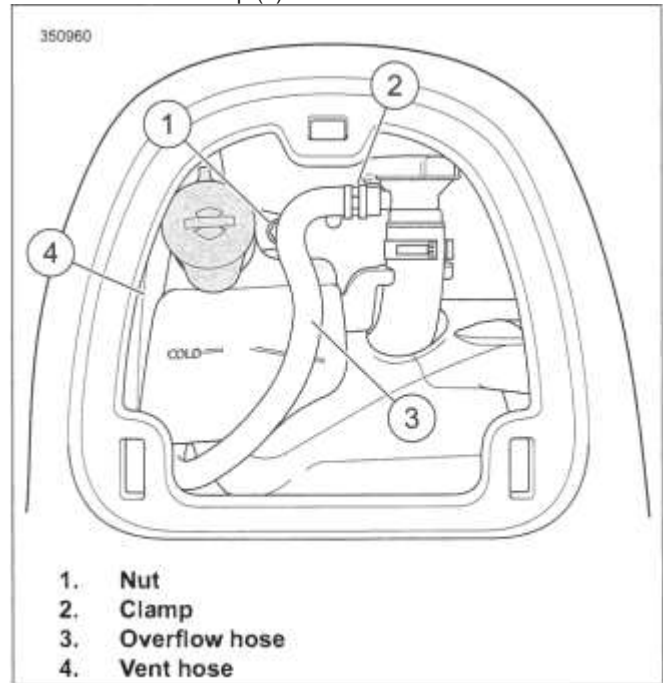


Figure 7-10. Remove Coolant Overflow Tank

## COMPLETE

1. Fill coolant overflow tank. See COOLANT (Page 7-8).
2. Install access panel.

1. Remove main fuse. See POWER DISCONNECT (Page 8-8).
2. Drain coolant. See COOLANT (Page 7-8).

**REMOVE AND INSTALL: HORIZONTAL TUBE**

**Remove**

| PART NUMBER | TOOL NAME               |
|-------------|-------------------------|
| HD-52004    | 24 INCH HOSE CLAMP TOOL |

*NOTE*

Use 24 INCH HOSE CLAMP TOOL (PART NUMBER: HD-52004) to reach rotated or difficult to reach spring clamps.

1. See Figure 7-11. Release retainers (4).
2. Remove clamps (2).
3. Disconnect hoses (1). Remove horizontal tube (3).

**Install**

1. See Figure 7-11. Place horizontal tube (3) in position. Connect hoses (1).
2. Install retainers (4)
3. Install clamps (2).

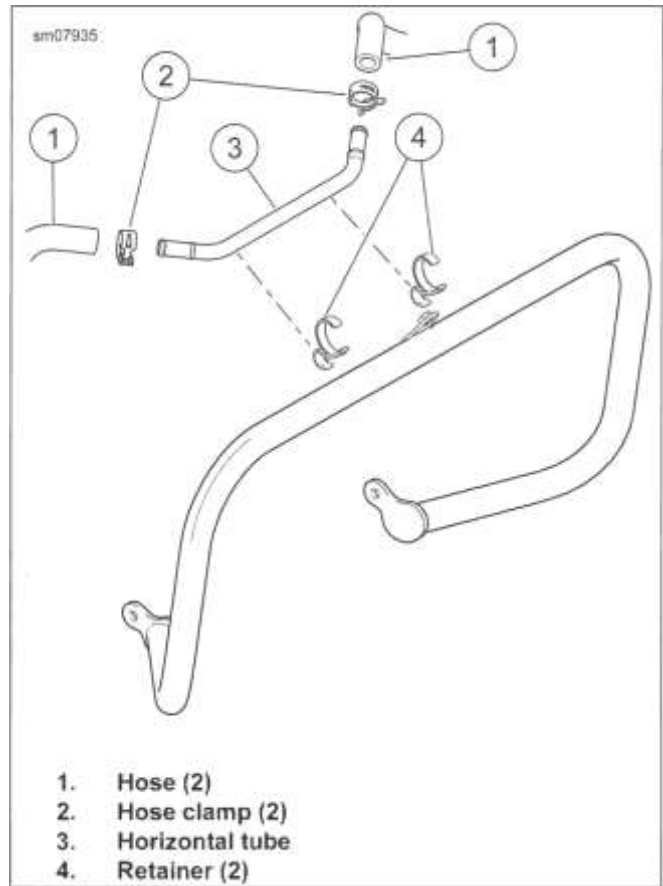


Figure 7-11. Coolant Horizontal Line

**REMOVE AND INSTALL: COOLANT HOSES**

**Inlet Left and Right Coolant Hoses, Radiator to Horizontal Downtube**

**Remove**

1. Remove coolant hose (1,10) from radiator (3,9). See RADIATOR (Page 7-18).
2. Remove coolant hose (1,10) from horizontal downtube (8). See Horizontal Downtube in this section.

**Install**

1. Install coolant hose (1,10) to radiator (3,9). See RADIATOR (Page 7-18).
2. Install coolant hose (1,10) to horizontal downtube (8). See Horizontal Downtube in this section.

**Outlet Coolant Hose, Left Radiator and Downtube**

**Remove**

1. Remove coolant hose (6) from radiator (9). See RADIATOR (Page 7-18).
2. Remove coolant hose (6) from downtube. See Downtube in this section.

- Discard cable straps (7).

Install

- Install coolant hose (6) to downtube. See Downtube in this section.
- Install coolant hose (6) to radiator. See RADIATOR (Page 7-18).
- Install **new** cable straps (7).

### Inlet Coolant Hose, Right Radiator to Coolant Pump

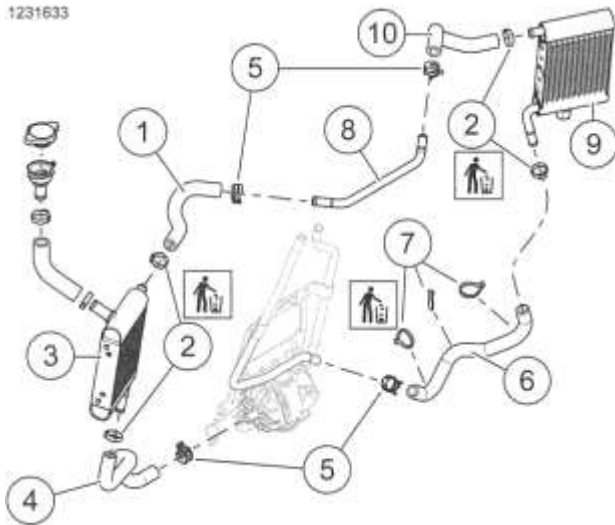
Remove

- Remove coolant hose (4) from radiator (3). See RADIATOR (Page 7-18).
- Remove coolant hose (4) from coolant pump. See COOLANT PUMP (Page 7-11).

Install

- Install coolant hose (4) to coolant pump. See COOLANT PUMP (Page 7-11).
- Install coolant hose (4) to radiator (3). See RADIATOR (Page 7-18).
  - Inlet hose, right radiator to horizontal tube**

1231633



- Clamps, crimp type (4)**
- Radiator, right**
- Inlet hose, right radiator to coolant pump**
- Hose clamps, spring type (4)**
- Outlet hose, left radiator to right downtube**
- Cable straps (3)**
- Horizontal tube**
- Radiator, left**
- Inlet hose, left radiator to horizontal tube**

Figure 7-12. Coolant Lines

## REMOVE AND INSTALL: COOLANT LINES

| PART NUMBER | TOOL NAME               |
|-------------|-------------------------|
| HD-52004    | 24 INCH HOSE CLAMP TOOL |

| FASTENER                     | TORQUE VALUE  |              |
|------------------------------|---------------|--------------|
| Coolant line manifold screws | 90-120 in-lbs | 10.2-13.6 Nm |

| PART NUMBER | CONSUMABLE  |
|-------------|---|
| 99642-97    | LOCTITE 243 MEDIUM STRENGTH THREADLOCKER AND SEALANT (BLUE) |

### Remove

- Remove fuel tank. See FUEL TANK (Page 6-10).
- Disconnect:
  - Fuel injector connectors. See FUEL INJECTORS (Page 6-25).
  - Knock sensor connectors. See KNOCK SENSOR (KS) (Page 8-97).
  - Left spark plug cables. See SPARK PLUG CABLES (Page 8-19).
  - ACR connectors. See AUTOMATIC COMPRESSION RELEASE (ACR) (Page 8-98).
  - Horn connectors. Release harness from clamp and cable strap. See HORN (Page 8-38).
- Remove stabilizer link and bracket. See FRONT ENGINE MOUNT (Page 4-22).
- See Figure 7-13. Remove screw (3) from each cylinder head.

#### NOTE

Use 24 INCH HOSE CLAMP TOOL (PART NUMBER: HD-52004) to reach rotated or difficult to reach spring cylinder head.

- Remove hose clamps at top of coolant downtubes. Separate upper hoses (2) from downtubes.
- Remove coolant line assembly.
- Discard O-rings from each manifold port (1).

### Inspect

- Clean components.
  - Remove all residual thread locking material from screws and manifolds.
  - Clean all debris from mating surfaces and threaded holes.
  - Clean all debris from coolant ports in heads and manifolds.

### Install

- See Figure 7-13. Install **new** O-rings on each manifold ports (1).

2. Set coolant line assembly in position.
3. Install screw (3) in each cylinder head.
  - a. Apply adhesive to threads.  
 LOCTITE 243 MEDIUM STRENGTH  
 THREADLOCKER AND SEALANT (BLUE) (99642-97)
  - b. Secure screws. Tighten.  
 Torque: 90-120 **in-lbs** (10.2-13.6 N-m) *Coolant line manifold screws*
4. Install hoses (2) to coolant downtubes. a.  
 Secure with hose clamps.
5. Connect:
  - a. Fuel injector connectors. See FUEL INJECTORS (Page 6-25).
  - b. Knock sensor connectors. See KNOCK SENSOR (KS) (Page 8-97).
  - c. Left spark plug cables. See SPARK PLUG CABLES (Page 8-19).
  - d. ACR connectors. See AUTOMATIC COMPRESSION RELEASE (ACR) (Page 8-98).
  - e. Horn connectors. Secure harness in clamp and **new** cable straps. See HORN (Page 8-38).
6. Install stabilizer link and bracket. See FRONT ENGINE MOUNT (Page 4-22).
7. Install fuel tank. See FUEL TANK (Page 6-10).

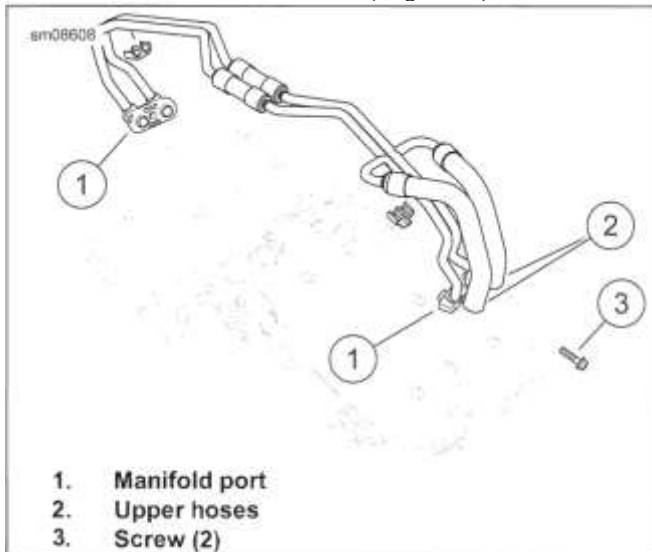


Figure 7-13. Upper Coolant Lines

## REMOVE AND INSTALL: COOLANT DOWNTUBES

| PART NUMBER | TOOL NAME               |
|-------------|-------------------------|
| HD-52004    | 24 INCH HOSE CLAMP TOOL |

### Remove

1. Remove coolant pump cover. See COOLANT PUMP (Page 7-11).

| FASTENER                      | TORQUE VALUE          |               |
|-------------------------------|-----------------------|---------------|
| Coolant downtube lower screws | 240-264 <b>in-lbs</b> | 27.1-29.8 N-m |
| Coolant downtube upper screws | 90-120 <b>in-lbs</b>  | 10.2-13.6 N-m |

| PART NUMBER | CONSUMABLE  |
|-------------|---|
| 99642-97    | LOCTITE 243 MEDIUM STRENGTH<br>THREADLOCKER AND SEALANT<br>(BLUE) |

2. Disconnect coolant pump electrical connector. See COOLANT PUMP (Page 7-11).
  3. See Figure 7-14. Remove upper hose connections (2) from downtubes.
  4. Disconnect hoses from lower connections (4).
- NOTE**  
 Use 24 INCH HOSE CLAMP TOOL (PART NUMBER: HD-52004) to reach rotated or difficult to reach spring clamps.
5. Remove screws (3, 5).
  6. Pull assembly away from frame and disconnect voltage regulator connectors.
  7. Remove downtube assembly.
  8. Remove voltage regulator. See VOLTAGE REGULATOR (Page 8-14).
  9. Remove coolant pump. See COOLANT PUMP (Page 7-11).

### Inspect

1. Verify that all tubes and hoses are free from debris internally.

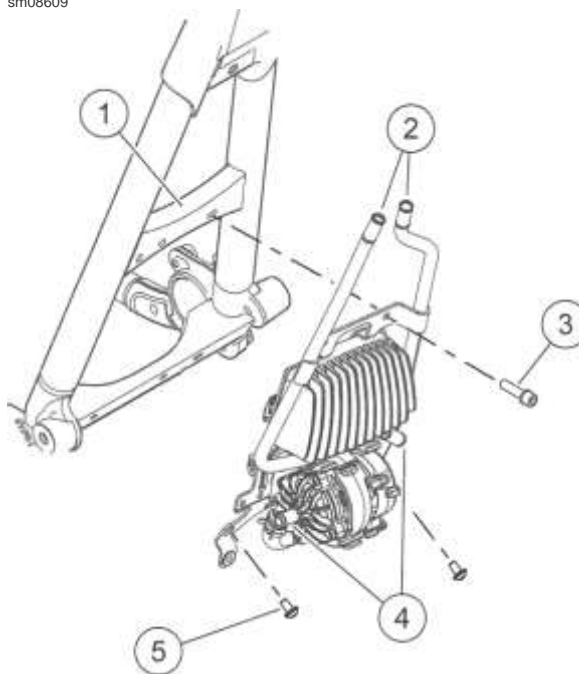
### Install

1. Install coolant pump. See COOLANT PUMP (Page 7-11).
2. Install voltage regulator. See VOLTAGE REGULATOR (Page 8-14).
  - a. Apply silicone based dielectric grease to both voltage regulator connectors.
  - b. Connect voltage regulator connectors as downtubes assembly is moved into place.
3. See Figure 7-14. Install downtube assembly with screws (3, 5)
  - a. Apply adhesive to threads of screws (3).

LOCTITE 243 MEDIUM STRENGTH  
THREADLOCKER AND SEALANT (BLUE) (99642-97)

sm08609

- b. Secure screws (3). Tighten.  
Torque: 90-120 **in-lbs** (10.2-13.6 N-m) *Coolant downtube upper screws*
- c. Secure screws (5). Tighten.  
Torque: 240-264 **in-lbs** (27.1-29.8 N-m) *Coolant • downtube lower screws*
4. Install hoses to upper connections (2).
  - a. Secure with **new** crimp clamps. See CRIMP CLAMPS (Page 4-16).
5. Install hoses to lower connections (4). a. Secure with spring clamps.
6. Connect pump electrical connector.
7. Install coolant pump cover. See COOLANT PUMP (Page 7-11).
8. Install fuel tank. See FUEL TANK (Page 6-10).



Frame cross member

Upper connections

Screw (2)

Lower connections

Lower screw (2)

Figure 7-14. Coolant Downtubes

## **COMPLETE**

1. Fill and bleed coolant system. See COOLANT (Page 7-8).
2. Install main fuse. See POWER DISCONNECT (Page 8-8).
3. Run motorcycle until engine is at normal operating temperature.
  - a. Check coolant level.
  - b. Check for leaks.

# RADIATOR ENGINE COOLANT TEMPERATURE (ECT) SENSOR

7.10  
7.9

## PREPARE

1. Remove main fuse. See POWER DISCONNECT (Page 8-8).
2. Drain coolant. See COOLANT (Page 7-8).
3. Disassemble left lower fairing. See COOLING FAN (Page 8-91).

## REMOVE

1. See Figure 7-15. Remove ECT sensor.
  - a. Disconnect connector.
  - b. Remove ECT sensor.

## INSTALL

| FASTENER                     | TORQUE VALUE                 |
|------------------------------|------------------------------|
| Temperature sensor, radiator | 17.7-19.2 ft-lbs   24-26 N-m |

| PART NUMBER | CONSUMABLE                 |
|-------------|----------------------------|
| 99818-97    | LOCTITE 565 THREAD SEALANT |

### NOTE

Avoid getting sealant on sensor probe.

1. Apply sealant to sensor.  
Consumable: LOCTITE 565 THREAD SEALANT (99818-97)

2. See Figure 7-15. Install ECT sensor.

- a. Install sensor. Tighten.  
Torque: 17.7-19.2 ft-lbs (24-26 N-m) *Temperature sensor, radiator*
- b. Install connector.

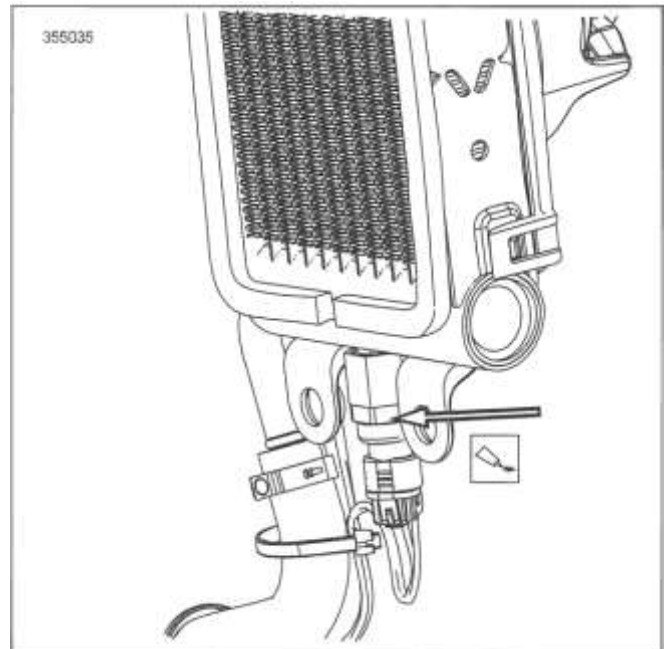


Figure 7-15. ECT Sensor (Left Lower Fairing)

## COMPLETE

1. Assemble left lower fairing. See COOLING FAN (Page 8-91).
2. Install main fuse. See POWER DISCONNECT (Page 8-8).
3. Fill and bleed coolant system. See COOLANT (Page 7-8).

## PREPARE \_\_\_\_\_

1. Remove main fuse. See POWER DISCONNECT (Page 8-8).
2. Drain coolant. See COOLANT (Page 7-8).
3. Disassemble lower fairing. See Disassemble and Assemble: Twin-Cooling in FAIRING LOWERS (Page 3-113).
4. Remove fan. See COOLING FAN (Page 8-91).

## REMOVE \_\_\_\_\_

1. See Figure 7-16. Remove inlet hose (5).
  - a. Discard Clamp (6).
  - b. Remove inlet hose (5).
2. Remove outlet hose (1).
  - a. Discard clamp (6)
  - b. Remove outlet hose (1).
3. Remove radiator (4).
4. **Right side:** Remove filler assembly (2), if necessary.
  - a. Remove clamp (3).
  - b. Remove filler assembly (2).
5. Remove gasket, if necessary.
6. **Left side:** Remove ECT sensor, if necessary. See ENGINE TEMPERATURE (ET) SENSOR (Page 8-96).

## INSTALL \_\_\_\_\_

1. See Figure 7-16. **Left side:** Install ECT sensor if removed. See ENGINE TEMPERATURE (ET) SENSOR (Page 8-96).
2. Install gasket, if removed.

3. **Right side:** Install filler assembly (2), if removed. a. Install clamp (3).
4. Install radiator (4).
5. Install outlet hose (1).
  - a. Install **new** clamp (6). See CRIMP CLAMPS (Page 4-16).
6. Install inlet hose (5).
  - a. Install **new** clamp (6). See CRIMP CLAMPS (Page 4-16).

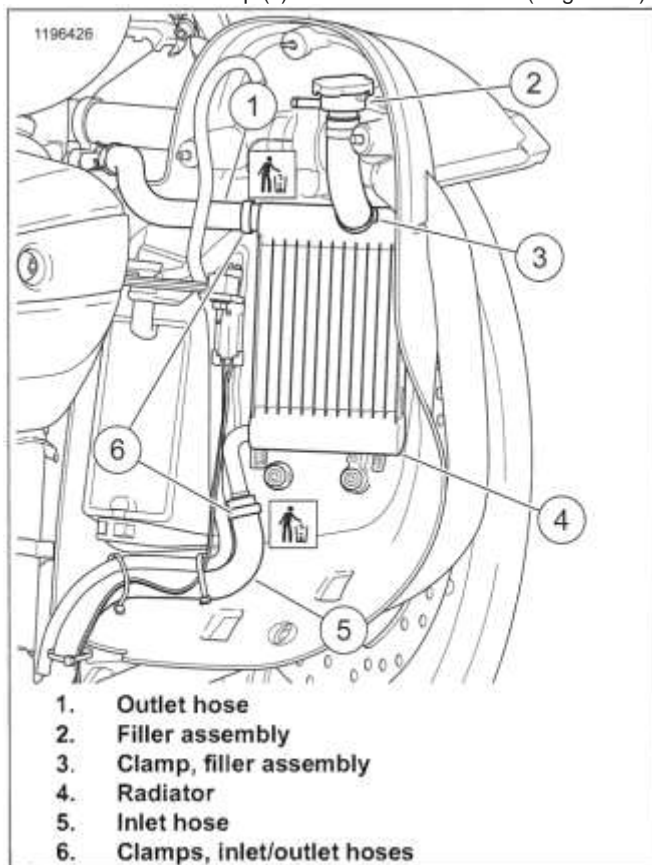


Figure 7-16. Radiator

## COMPLETE

1. Fill and bleed coolant system. See COOLANT (Page 7-8).

| SUBJECT  | PAGE NO.    |
|--|-------------|
| 8.1 FASTENER TORQUE VALUES.....                | 8-1         |
| 8.2 SPECIFICATIONS.....                        | 8-5         |
| 8.3 FUSES AND RELAYS.....                      | <b>8-6</b>  |
| 8.4 POWER DISCONNECT.....                      | <b>8-8</b>  |
| 8.5 FAIRING POWER OUTLET.....                  | 8-10        |
| 8.6 STARTER.....                               | 8-11        |
| 8.7 ALTERNATOR.....                            | 8-12        |
| 8.8 VOLTAGE REGULATOR.....                     | 8-14        |
| 8.9 IGNITION SWITCH.....                       | 8-16        |
| 8.10 SPARK PLUG CABLES.....                    | 8-19        |
| 8.11 IGNITION COIL.....                        | 8-20        |
| 8.12 LEFT HAND CONTROL MODULE (LHCM).....      | 8-22        |
| 8.13 RIGHT HAND CONTROL MODULE (RHCM).....     | 8-25        |
| 8.14 ACCESSORY SWITCHES.....                   | 8-28        |
| 8.15 INSTRUMENT MODULE (IM).....               | 8-31        |
| 8.16 INDICATOR LAMPS.....                      | 8-33        |
| 8.17 FAIRING GAUGES.....                       | 8-34        |
| 8.18 FUEL LEVEL GAUGE.....                     | 8-35        |
| 8.19 OIL PRESSURE SWITCH.....                  | 8-36        |
| 8.20 NEUTRAL INDICATOR SWITCH.....             | 8-37        |
| 8.21 HORN.....                                 | 8-38        |
| 8.22 HEADLAMP.....                             | 8-41        |
| 8.23 AUXILIARY LAMPS.....                      | 8-46        |
| 8.24 FRONT TURN SIGNAL LAMPS.....              | 8-49        |
| 8.25 FRONT FENDER TIP LAMP.....                | 8-52        |
| 8.26 REAR TURN SIGNAL LAMPS.....               | 8-54        |
| 8.27 TAIL LAMP.....                            | 8-59        |
| 8.28 REAR FENDER TIP LAMP.....                 | 8-61        |
| 8.29 TOUR-PAK LIGHTING.....                    | 8-62        |
| 8.30 REAR STOPLAMP SWITCH.....                 | 8-65        |
| 8.31 LICENSE PLATE LAMP.....                   | <b>8-66</b> |
| 8.32 RADIO.....                                | 8-67        |
| 8.33 FRONT SPEAKERS.....                       | 8-70        |
| 8.34 REAR SPEAKERS.....                        | 8-73        |
| 8.35 PASSENGER AUDIO CONTROLS.....             | 8-76        |
| 8.36 RIDER HEADSET CONNECTOR.....              | 8-77        |
| 8.37 CB MODULE.....                            | 8-78        |
| 8.38 GPS ANTENNA.....                          | 8-79        |
| 8.39 ANTENNA CABLES.....                       | 8-80        |
| 8.40 ELECTRONIC CONTROL MODULE (ECM).....      | 8-83        |
| 8.41 BODY CONTROL MODULE (BCM).....            | 8-84        |
| 8.42 SECURITY SYSTEM ACTIVATION.....           | 8-85        |
| 8.43 PERSONAL IDENTIFICATION NUMBER (PIN)..... | <b>8-86</b> |
| 8.44 SECURITY SYSTEM MAINTENANCE.....          | 8-87        |
| 8.45 SECURITY SIREN.....                       | 8-89        |
| 8.46 SECURITY SYSTEM ANTENNA.....              | 8-90        |
| 8.47 COOLING FAN.....                          | 8-91        |
| 8.48 AMBIENT AIR TEMPERATURE SENSOR.....       | 8-94        |
| 8.49 CRANKSHAFT POSITION SENSOR (CKP).....     | 8-95        |
| 8.50 ENGINE TEMPERATURE (ET) SENSOR.....       | 8-96        |
| 8.51 KNOCK SENSOR (KS).....                    | 8-97        |
| 8.52 AUTOMATIC COMPRESSION RELEASE (ACR).....  | 8-98        |
| 8.53 FRONT WHEEL SPEED SENSOR (WSS).....       | 8-100       |
| 8.54 REAR WHEEL SPEED SENSOR (WSS).....        | 8-102       |
| 8.55 INERTIAL MEASUREMENT UNIT (IMU).....      | 8-103       |
| 8.56 JIFFY STAND SENSOR (JSS).....             | 8-104       |
| 8.57 WIRE TROUGH.....                          | 8-105       |
| 8.58 TOP CADDY.....                            | 8-107       |
| 8.59 LEFT SIDE CADDY.....                      | 8-108       |
| 8.60 RIGHT SIDE CADDY.....                     | 8-110       |
| 8.61 LOWER BACKBONE CADDY.....                 | 8-112       |



8.62 BATTERY TRAY .....8-113  
8.63 TOUR-PAK WIRE HARNESS .....8-114  
8.64 FAIRING WIRE HARNESS .....8-116  
8.65 MAIN WIRE HARNESS .....8-119



| FASTENER  | TORQUE VALUE  |               | NOTES   |
|---|---------------|---------------|---|
| ABS module locknuts   | 53-88 in-lbs  | 6-9.9 N-m     | 8.60 RIGHT SIDE CADDY, Install                                      |
| Accessory switch module screw   | 12-17 in-lbs  | 1.4-1.9 N-m   | 8.14 ACCESSORY SWITCHES, Remove and Install: Fork Mounted Fairing   |
| Accessory switch module screw   | 12-17 in-lbs  | 1.4-1.9 N-m   | 8.14 ACCESSORY SWITCHES, Remove and Install: Frame Mounted Fairing  |
| ACR   | 17-19 ft-lbs  | 23-26.4 N-m   | 8.52 AUTOMATIC COMPRESSION RELEASE (ACR), Install                   |
| Air duct nut, lower fairing   | 65-75 in-lbs  | 7.3-8.4 N-m   | 8.47 COOLING FAN, Install   |
| Air duct screws, lower fairing  | 65-75 in-lbs  | 7.3-8.4 N-m   | 8.47 COOLING FAN, Install   |
| AM/FM antenna stud nut  | 16-19 in-lbs  | 1.8-2.1 N-m   | 8.29 TOUR-PAK LIGHTING, Remove and Install: Wrap-Around Lamp        |
| Auxiliary/fog lamp door screw   | 10-14 in-lbs  | 1.1-1.6 N-m   | 8.23 AUXILIARY LAMPS, Bulb Replacement                              |
| Auxiliary/fog lamp flange nut: Models with bullet style turn signal lamps | 20-24 ft-lbs  | 27.1-32.5 N-m | 8.22 HEADLAMP, Adjust   |
| Auxiliary/fog lamp flange nut: Models with flat lens turn signal lamps    | 15-18 ft-lbs  | 20.3-24.4 N-m | 8.22 HEADLAMP, Adjust   |
| Auxiliary/fog lamp stud locknut   | 20-24 ft-lbs  | 27.1-32.5 N-m | 8.23 AUXILIARY LAMPS, Install                                       |
| Battery hold-down screws  | 32-40 in-lbs  | 3.6-4.5 N-m   | 8.11 IGNITION COIL, Install   |
| Battery tray to frame screw   | 11-13 ft-lbs  | 14.9-17.6 N-m | 8.62 BATTERY TRAY, Install  |
| CB antenna base set screw   | 14-16 in-lbs  | 1.6-1.8 N-m   | 8.29 TOUR-PAK LIGHTING, Remove and Install: Wrap-Around Lamp        |
| CB antenna stud nut   | 14-16 in-lbs  | 1.6-1.8 N-m   | 8.29 TOUR-PAK LIGHTING, Remove and Install: Wrap-Around Lamp        |
| CB antenna stud nut   | 14-16 in-lbs  | 1.6-1.8 N-m   | 8.63 TOUR-PAK WIRE HARNESS, Install                                 |
| CB module bracket to speaker enclosure screw                              | 25-35 in-lbs  | 2.8-4 N-m     | 8.37 CB MODULE, Install   |
| CKP mount screw   | 90-120 in-lbs | 10.2-13.6 N-m | 8.49 CRANKSHAFT POSITION SENSOR (CKP), Install                      |
| Coolant bottle nut  | 65-74 in-lbs  | 7.3-8.4 N-m   | 8.47 COOLING FAN, Complete  |
| Coolant downtube lower screws   | 20-22 ft-lbs  | 27.1-29.8 N-m | 8.8 VOLTAGE REGULATOR, Install                                      |
| Coolant downtube upper screws   | 90-110 in-lbs | 10.2-12.4 N-m | 8.8 VOLTAGE REGULATOR, Install                                      |
| Dash panel screw  | 25-30 in-lbs  | 2.8-3.4 N-m   | 8.64 FAIRING WIRE HARNESS, Remove and Install: Fork Mounted Fairing |
| ET sensor   | 11-16 ft-lbs  | 14.9-21.2 N-m | 8.50 ENGINE TEMPERATURE (ET) SENSOR, Install                        |
| Fairing gauge screw   | 8-15 in-lbs   | 0.9-1.7 N-m   | 8.17 FAIRING GAUGES, Install  |
| Fairing speaker enclosure to fairing screws                               | 48-60 in-lbs  | 5.4-6.8 N-m   | 8.33 FRONT SPEAKERS, Remove and Install: Fork Mounted Fairing       |
| Fairing speaker enclosure to fairing support screws                       | 48-60 in-lbs  | 5.4-6.8 N-m   | 8.33 FRONT SPEAKERS, Remove and Install: Fork Mounted Fairing       |
| Fairing speaker grille screws   | 9-13 in-lbs   | 1-1.5 N-m     | 8.33 FRONT SPEAKERS, Remove and Install: Fork Mounted Fairing       |
| Fairing speaker screws  | 9-13 in-lbs   | 1-1.5 N-m     | 8.33 FRONT SPEAKERS, Remove and Install: Fork Mounted Fairing       |
| Fascia lamp screw   | 18-22 in-lbs  | 2-2.5 N-m     | 8.28 REAR FENDER TIP LAMP, Remove and Install: Fascia Lamp          |
| Fender tip lamp, front  | 20-25 in-lbs  | 2.3-2.8 N-m   | 8.25 FRONT FENDER TIP LAMP, Install                                 |

| FASTENER  | TORQUE VALUE   |               | NOTES   |
|---|----------------|---------------|---|
| Fender trim strips, front                       | 10-15 in-lbs   | 1.1—1.7 N-m   | 8.25 FRONT FENDER TIP LAMP, Install                                 |
| Front turn signal mounting screw: bullet style  | 96-120 in-lbs  | 10.9-13.6 N-m | 8.23 AUXILIARY LAMPS, Install                                       |
| Glove box screws, lower fairing                 | 12-16 in-lbs   | 1.4-1.8 N-m   | 8.47 COOLING FAN, Complete  |
| Ground plate/marker lamp screws                 | 20-25 in-lbs   | 2.3-2.8 N-m   | 8.29 TOUR-PAK LIGHTING, Remove and Install: Side Lamps/Trim Strips  |
| Harness ground stud flange nut                  | 50-90 in-lbs   | 5.7-10.2 N-m  | 8.11 IGNITION COIL, Install   |
| Harness ground stud flange nut                  | 50-90 in-lbs   | 5.7-10.2 N-m  | 8.65 MAIN WIRE HARNESS, Remove and Install: Common Components       |
| Headlamp bezel: Dual headlamp                   | 8-15 in-lbs    | 0.9-1.7 N-m   | 8.22 HEADLAMP, Remove and Install: Dual Headlamp                    |
| Headlamp door screw                             | 9-18 in-lbs    | 1-2 N-m       | 8.22 HEADLAMP, Remove and Install: Single Headlamp                  |
| Headlamp retaining ring screws: Single headlamp | 23-26 in-lbs   | 2.6-2.9 N-m   | 8.22 HEADLAMP, Remove and Install: Single Headlamp                  |
| Headlamp screws: Dual headlamp                  | 48-60 in-lbs   | 5.4-6.8 N-m   | 8.22 HEADLAMP, Remove and Install: Dual Headlamp                    |
| Horn bracket acorn nut                          | 80-120 in-lbs  | 9-13.6 N-m    | 8.21 HORN, Install  |
| Horn bracket to cylinder head screws            | 35-40 ft-lbs   | 47.5-54.2 N-m | 8.21 HORN, Install  |
| Horn cover to bracket                           | 35-40 in-lbs   | 3.9-4.5 N-m   | 8.21 HORN, Assemble   |
| Horn rubber mount                               | 120-180 in-lbs | 13.6-20.3 N-m | 8.21 HORN, Install  |
| Horn stud flange nut                            | 80-100 in-lbs  | 9-11.3 N-m    | 8.21 HORN, Assemble   |
| Ignition coil screws                            | 32-40 in-lbs   | 3.6-4.5 N-m   | 8.11 IGNITION COIL, Install   |
| Ignition switch housing screws: Fairing models  | 85-115 in-lbs  | 9.6-13 N-m    | 8.9 IGNITION SWITCH, Remove and Install: Fairing Models             |
| Ignition switch screws: Road King               | 25-35 in-lbs   | 2.8-3.9 N-m   | 8.9 IGNITION SWITCH, Remove and Install: Non-Fairing Models         |
| IM screw: Fork-mounted fairing                  | 10-20 in-lbs   | 1.1-2.3 N-m   | 8.15 INSTRUMENT MODULE (IM), Install                                |
| IM screw: Frame-mounted fairing                 | 12-17 in-lbs   | 1.4—1.9 N-m   | 8.15 INSTRUMENT MODULE (IM), Install                                |
| IMU screw                                       | 32-40 in-lbs   | 3.6-4.5 N-m   | 8.55 INERTIAL MEASUREMENT UNIT (IMU), Install                       |
| Inner fairing to fork bracket studs             | 120-180 in-lbs | 13.6-20.3 N-m | 8.64 FAIRING WIRE HARNESS, Remove and Install: Fork Mounted Fairing |
| Jiffy stand sensor screw                        | 96-120 in-lbs  | 10.8-13.6 N-m | 8.56 JIFFY STAND SENSOR (JSS), Install                              |
| Knock sensor screw                              | 13-17 ft-lbs   | 17.6-23 N-m   | 8.51 KNOCK SENSOR (KS), Install                                     |
| Left caddy screws                               | 72-96 in-lbs   | 8.1-10.9 N-m  | 8.59 LEFT SIDE CADDY, Install                                       |
| LHCM housing screw.                             | 35-44 in-lbs   | 4-5 N-m       | 8.12 LEFT HAND CONTROL MODULE (LHCM), Install                       |
| License plate bracket screws                    | 60-80 in-lbs   | 6.8-9 N-m     | 8.26 REAR TURN SIGNAL LAMPS, Remove and Install: Bullet Style       |
| License plate bracket screws                    | 60-80 in-lbs   | 6.8-9 N-m     | 8.26 REAR TURN SIGNAL LAMPS, Remove and Install: Flat Lens Style    |
| Lower fairing cap flange nut                    | 30-35 in-lbs   | 3.4-3.9 N-m   | 8.47 COOLING FAN, Complete  |
| Nacelle switch hex nut                          | 9-15 in-lbs    | 1-1.7 N-m     | 8.14 ACCESSORY SWITCHES, Remove and Install: Nacelle Mounted        |
| Negative battery cable screw                    | 60-70 in-lbs   | 6.8-7.9 N-m   | 8.4 POWER DISCONNECT, Negative Battery Cable                        |
| Passenger audio switch screws                   | 25-30 in-lbs   | 2.8-3.4 N-m   | 8.34 REAR SPEAKERS, Assemble  |
| Passenger headset connector nut                 | 7-9 in-lbs     | 0.8-1 N-m     | 8.34 REAR SPEAKERS, Assemble  |
| Radio antenna base inner set screw              | 14-16 in-lbs   | 1.6—1.8 N-m   | 8.29 TOUR-PAK LIGHTING, Remove and Install: Wrap-Around Lamp        |

| FASTENER   | TORQUE VALUE   |               | NOTES  |
|--|----------------|---------------|--|
| Radio to fairing support bracket screws  | 60-84 in-lbs   | 6.8-9.5 N-m   | 8.32 RADIO, Remove and Install: Frame Mounted Fairing  |
| Radio-to-upper support bracket screw   | 60-84 in-lbs   | 6.8-9.5 N-m   | 8.32 RADIO, Remove and Install: Fork Mounted Fairing   |
| Radio upper bracket: FLTR  | 25-35 in-lbs   | 2.8-4 N-m     | 8.32 RADIO, Remove and Install: Frame Mounted Fairing  |
| Rear lightbar screw  | 84-120 in-lbs  | 9.5-13.6 N-m  | 8.26 REAR TURN SIGNAL LAMPS, Remove and Install: Flat Lens Style   |
| Rear speaker enclosure to Tour-Pak screws  | 20-25 in-lbs   | 2.3-2.8 N-m   | 8.34 REAR SPEAKERS, Install  |
| Rear stop lamp switch  | 144 in-lbs     | 16.3 N-m      | 8.30 REAR STOPLAMP SWITCH, Install   |
| Rear turn signal to lightbar screw   | 30-50 in-lbs   | 3.4-5.6 N-m   | 8.26 REAR TURN SIGNAL LAMPS, Remove and Install: Flat Lens Style   |
| RHCM housing screw   | 35-44 in-lbs   | 4-5 N-m       | 8.13 RIGHT HAND CONTROL MODULE (RHCM), Install   |
| Rider headset connector nut  | 7-9 in-lbs     | 0.8-1 N-m     | 8.36 RIDER HEADSET CONNECTOR, Install  |
| Right caddy to battery tray screw  | 36-40 in-lbs   | 4.1-4.5 N-m   | 8.60 RIGHT SIDE CADDY, Install   |
| Spark plug   | 89-133 in-lbs  | 10-15 N-m     | 8.2 SPECIFICATIONS, Specifications   |
| Speaker enclosure mounting screws, front, FLTR                                       | 48-60 in-lbs   | 5.4-6.8 N-m   | 8.33 FRONT SPEAKERS, Remove and Install: Frame Mounted Fairing   |
| Speaker mounting screws  | 9-13 in-lbs    | 1-1.5 N-m     | 8.33 FRONT SPEAKERS, Remove and Install: Frame Mounted Fairing   |
| Speaker mounting screws  | 9-13 in-lbs    | 1-1.5 N-m     | 8.33 FRONT SPEAKERS, Remove and Install: Frame Mounted Fairing   |
| Starter mounting screw   | 22-24 ft-lbs   | 29.8-32.5 N-m | 8.6 STARTER, Install<br>Apply a light coat of LOCTITE 243 MEDIUM STRENGTH THREADLOCKER AND SEALANT (BLUE) (99642-97)                 |
| Starter solenoid stud nut  | 70-104 in-lbs  | 7.9-11.8 N-m  | 8.6 STARTER, Install   |
| Stator mounting screws   | 55-75 in-lbs   | 6.2-8.5 N-m   | 8.7 ALTERNATOR, Install<br>Always use new screws   |
| Switch, Neutral Indicator  | 120-180 in-lbs | 13.6-20.3 N-m | 8.20 NEUTRAL INDICATOR SWITCH, Install   |
| Switch, Oil Pressure   | 13-17 ft-lbs   | 17-23 N-m     | 8.19 OIL PRESSURE SWITCH, Install  |
| Tail lamp base screw   | 40-48 in-lbs   | 4.5-5.4 N-m   | 8.27 TAIL LAMP, Install  |
| Tail lamp screws   | 20-24 in-lbs   | 2.3-2.7 N-m   | 8.27 TAIL LAMP, Bulb Replacement   |
| Top caddy screws   | 72-96 in-lbs   | 8.1-10.9 N-m  | 8.58 TOP CADDY, Install  |
| Tour-Pak ground plate screw  | 20-25 in-lbs   | 2.3-2.8 N-m   | 8.63 TOUR-PAK WIRE HARNESS, Install  |
| Turn/aux/fog lamp bracket acorn nut, fairing models                                  | 120-180 in-lbs | 13.6-20.3 N-m | 8.23 AUXILIARY LAMPS, Install  |
| Turn/aux/fog lamp bracket acorn nut, road king models                                | 72-108 in-lbs  | 8.1-12.2 N-m  | 8.23 AUXILIARY LAMPS, Install  |
| Turn signal lamp, front, mounting bracket screws: Flat lens style                    | 36-60 in-lbs   | 4.1-6.8 N-m   | 8.24 FRONT TURN SIGNAL LAMPS, Remove and Install: Light Bar Mount  |
| Turn signal lamps bracket, rear, screws  | 84-144 in-lbs  | 9.5-16.3 N-m  | 8.26 REAR TURN SIGNAL LAMPS, Remove and Install: Bullet Style<br>LOCTITE 262 HIGH STRENGTH THREADLOCKER AND SEALANT (RED) (94759-99) |
| Turn signal lamp to auxiliary/fog lamp bracket screw: Bullet style turn signal lamps | 96-120 in-lbs  | 10.9-13.5 N-m | 8.22 HEADLAMP, Adjust  |
| Turn signal lamp to auxiliary/fog lamp bracket screws: Flat lens turn signal lamps   | 36-60 in-lbs   | 4.1-6.8 N-m   | 8.22 HEADLAMP, Adjust  |

| FASTENER  | TORQUE VALUE  |               | NOTES   |
|---|---------------|---------------|---|
| Upper support bracket to speaker enclosure screws | 48-60 in-lbs  | 5.4-6.8 N-m   | 8.33 FRONT SPEAKERS, Remove and Install: Fork Mounted Fairing |
| Voltage regulator screws                          | 96-120 in-lbs | 10.8-13.6 N-m | 8.8 VOLTAGE REGULATOR, Install                                |
| Wrap-around lamp screws                           | 20-25 in-lbs  | 2.3-2.8 N-m   | 8.29 TOUR-PAK LIGHTING, Remove and Install: Wrap-Around Lamp  |

**SPECIFICATIONS**

| FASTENER   | TORQUE VALUE                     |
|------------|----------------------------------|
| Spark plug | 89-133 <b>in-lbs</b> [ 10-15 N-m |

**Table 8-1. Ignition**

| IGNITION                           | DATA                             |
|------------------------------------|----------------------------------|
| Spark plug size                    | <b>10 mm</b>                     |
| Spark plug gap                     | 0.031-0.035 in (0.8-0.9 mm)      |
| Spark plug torque                  | 89-133 <b>in-lbs</b> (10-15 N-m) |
| Spark plug cable resistance        | Front Left: 94,500-256,000 Q     |
|                                    | Front Right: 88,500-240,000 Q    |
|                                    | Rear:<br>45,750-126,000 Q        |
| Ignition coil primary resistance   | 0.3-1.5 Q                        |
| Ignition coil secondary resistance | 8,000-12,000 Q                   |

**Table 8-2. Fuses**

| FUSE         | AMPS |
|--------------|------|
| Main fuse    | 50 A |
| System power | 7.5A |
| P&A          | 20A  |
| Radio power  | 20A  |
| Cooling      | 15A  |
| Battery      | 5A   |

**Table 8-3. Charging System**

| CHARGING SYSTEM                   | DATA                   |
|-----------------------------------|------------------------|
| Battery                           | 28 Ah /405 CCA         |
| Alternator AC voltage output      | 40-55 VAC at 2,000 rpm |
| Alternator stator coil resistance | 0.1-0.3 Q              |
| Maximum output                    | 46-50 A                |

**Table 8-4. Starter Specifications**

| STARTER DATA     |                                       |
|------------------|---------------------------------------|
| Free current     | 90 A (max) @ 11.5 V                   |
| Cranking current | -  250 A (max) @ <b>68</b> °F (20 °C) |

## PREPARE

1. Remove left saddlebag. See SADDLEBAGS (Page 3-161)
2. Remove left side cover. See LEFT SIDE COVER (Page 3-62)

## REMOVE

### Main Fuse

1. **Models with security:** Disable security system.
  - a. Verify that fob is present.
  - b. Turn OFF/RUN switch to RUN.
  - c. Turn ignition switch ON.
2. See Figure 8-1. Remove main fuse (4).
3. **Models with security:** Turn ignition switch OFF.

### Fuses and Relays

1. Remove fuse block cover.
  - a. Press in tabs on the left and right sides of fuse block cover.
  - b. Remove fuse block cover.
2. See Figure 8-2. Remove fuse or relay, if needed.

## INSTALL

### Fuses and Relays

1. See Figure 8-2. Install fuse or relay, if removed.
2. Install fuse block cover.
  - a. Install tabs on left and right side of fuse block cover.

### Main Fuse

1. See Figure 8-1. Install main fuse (4).

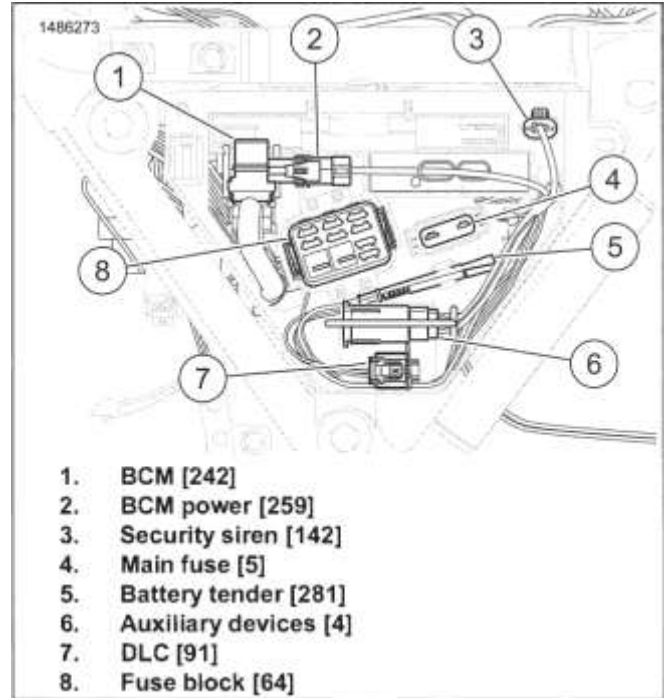
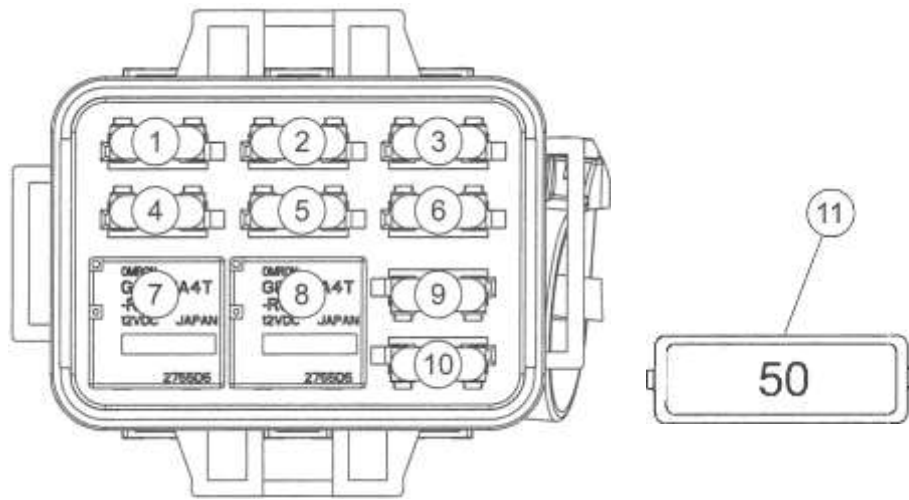


Figure 8-1. Behind Left Side Cover





- |                         |                      |
|-------------------------|----------------------|
| 1. Radio power (20 A)   | 7. P&A relay         |
| 2. System power (7.5 A) | 8. Cooling relay     |
| 3. Battery (5 A)        | 9. Spare (7.5 A)     |
| 4. P&A (20 A)           | 10. Spare (20 A)     |
| 5. Cooling (15 A)       | 11. Main fuse (50 A) |
| 6. Spare (5 A)          |                      |

Figure 8-2. Fuses and Relays

**COMPLETE**

1. Install left side cover. See LEFT SIDE COVER (Page 3-62)
2. Install left saddlebag. See SADDLEBAGS (Page 3-161)

**A WARNING**

Be sure that all lights and switches operate properly before operating motorcycle. Low visibility of rider can result in death or serious injury. (00316a)

3. Test affected circuit for proper operation.

# POWER DISCONNECT

## MAIN FUSE

Remove main fuse when there is a possibility of injury caused by accidental vehicle start-up or electrical equipment damage.

### Remove Main Fuse

1. **Models with security:** Disable security system.
  - a. Verify that fob is present.
  - b. Turn OFF/RUN switch to RUN.
  - c. Turn ignition switch ON.
2. Remove left saddlebag. See SADDLEBAGS (Page 3-161)
3. Remove left side cover. See LEFT SIDE COVER (Page 3-62)

#### A WARNING

To prevent accidental vehicle start-up, which could cause death or serious injury, remove main fuse before proceeding. (00251b)

4. See Figure 8-3. Remove main fuse (4).
5. **Models with security:** Turn ignition switch OFF.

### Install Main Fuse

1. See Figure 8-3. Install main fuse (4).
2. Install left side cover. See LEFT SIDE COVER (Page 3-62)
3. Install left saddlebag. See SADDLEBAGS (Page 3-161)

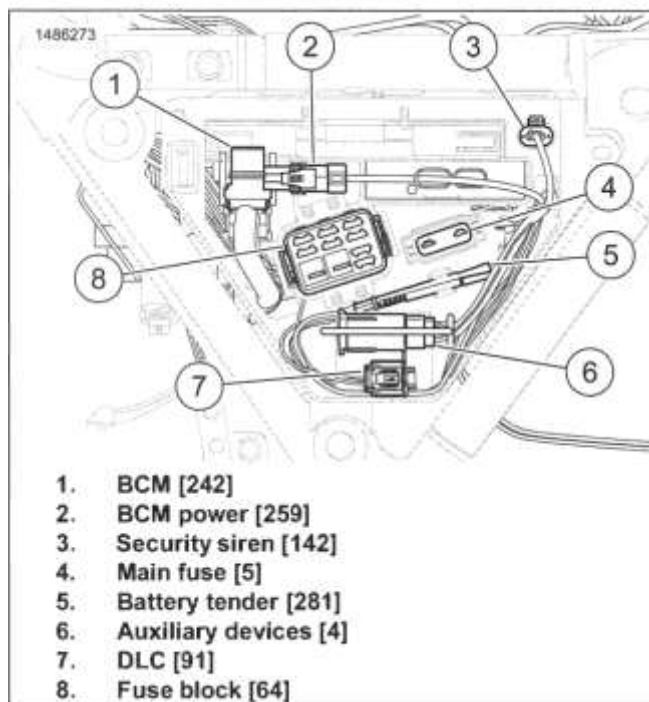


Figure 8-3. Behind Left Side Cover

### NEGATIVE BATTERY CABLE

| FASTENER                     | TORQUE VALUE               |
|------------------------------|----------------------------|
| Negative battery cable screw | 60-70 in-lbs 1 6.8-7.9 N-m |

Disconnect negative battery cable from battery when there is a possibility of injury caused by starter engagement (engine rotation).

### Disconnect Negative Battery Cable

1. **Models with security:** Disable security system.
  - a. Verify that fob is present.
  - b. Turn OFF/RUN switch to RUN.
  - c. Turn ignition switch ON.
2. Remove seat. See SEAT (Page 3-148)
3. See Figure 8-4. Detach Electronic Control Module (ECM) (1) from top caddy.

#### A WARNING

To prevent accidental vehicle start-up, which could cause death or serious injury, disconnect negative (■) battery cable before proceeding. (00048a)

4. Disconnect negative battery cable. Remove battery cable screw (2).
5. **Models with security:** Turn ignition switch OFF.

### Connect Negative Battery Cable

1. See Figure 8-4. Connect negative battery cable. Tighten.

Torque: 60-70 **in-lbs** (6.8-7.9 N-m) *Negative battery cable screw*

2. Attach ECM (1).

3. Install seat. See SEAT (Page 3-148)

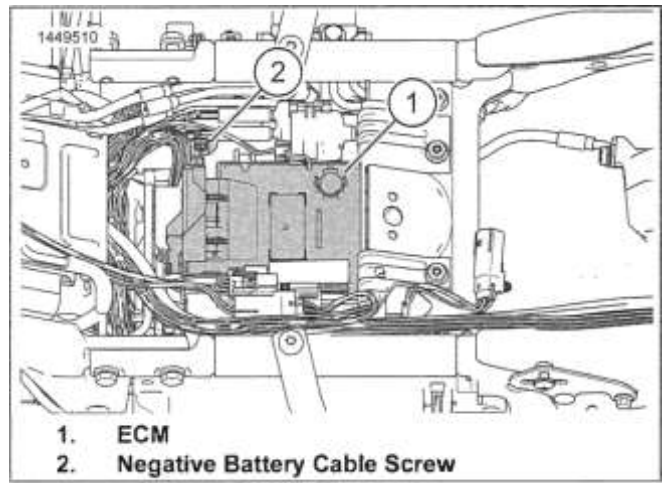


Figure 8-4. Top Caddy

## **PREPARE**

### *NOTE*

*Do not use power outlet as a cigarette lighter. Socket damage may occur.*

1. Remove left saddlebag. See SADDLEBAGS (Page 3-161 ).
2. Remove left side cover. See LEFT SIDE COVER (Page 3-62).
3. Remove main fuse. See POWER DISCONNECT (Page 8-8).
4. Remove outer fairing and windshield. See FAIRING: FORK MOUNTED (Page 3-89).

## **REMOVE**

1. Disconnect power connector.
2. Hold socket and loosen outer shell.

3. Remove socket and outer shell from inner fairing.

## **INSTALL**

1. Slide power outlet socket through bore in fairing.
2. Install outer shell and tighten securely.
3. Install power connector.

## **COMPLETE**

1. Install outer fairing and windshield. See FAIRING: FORK MOUNTED (Page 3-89).
2. Install main fuse. See POWER DISCONNECT (Page 8-8).
3. Install left side cover. See LEFT SIDE COVER (Page 3-62).
4. Install left saddlebag. See SADDLEBAGS (Page 3-161).

## PREPARE

1. Disconnect negative battery cable. See POWER DISCONNECT (Page 8-8)

## REMOVE

1. Remove engine oil filler cap/dipstick.
  - a. Remove cap/dipstick.
  - b. Cover fill spout with clean shop cloth to keep out dirt and debris.
2. See Figure 8-5. Remove starter.
  - a. Remove battery positive cable from starter solenoid stud (3).
  - b. Disconnect stater solenoid connector (4).
  - c. Remove starter mounting screws (2).
  - d. Remove starter.

**NOTE**

Do not allow ring dowels (1) to drop when removing starter.

3. Discard O-ring (5).

## INSTALL

| PART NUMBER | CONSUMABLE  |
|-------------|---|
| 99642-97    | LOCTITE 243 MEDIUM STRENGTH THREADLOCKER AND SEALANT (BLUE) |
| 99857-97A   | SPECIAL PURPOSE GREASE                                      |

1. See Figure 8-5. Install starter.
  - a. Apply a light coat of grease on new O-Ring (5).  
SPECIAL PURPOSE GREASE (99857-97A)
  - b. Install new O-Ring.
  - c. Apply a light coat of threadlocker to starter mounting screws (2).

LOCTITE 243 MEDIUM STRENGTH  
THREADLOCKER AND SEALANT (BLUE) (99642-97)

- d. Install starter.

**NOTE**

Verify that ring dowels (1) are installed.

- e. Install starter mounting screws. Tighten.  
Torque: 22-24 ft-lbs (29.8-32.5 N-m) *Starter mounting screw*
- f. Install battery positive cable on starter solenoid stud (3).
- g. Install starter solenoid nut on starter solenoid stud. Tighten.  
Torque: 70-104 in-lbs (7.9-11.8 N-m) *Starter solenoid stud nut*
- h. Pull down rubber boot over terminal connection.
- i. Install starter solenoid connector (4).

2. Install engine oil filler cap/dipstick.

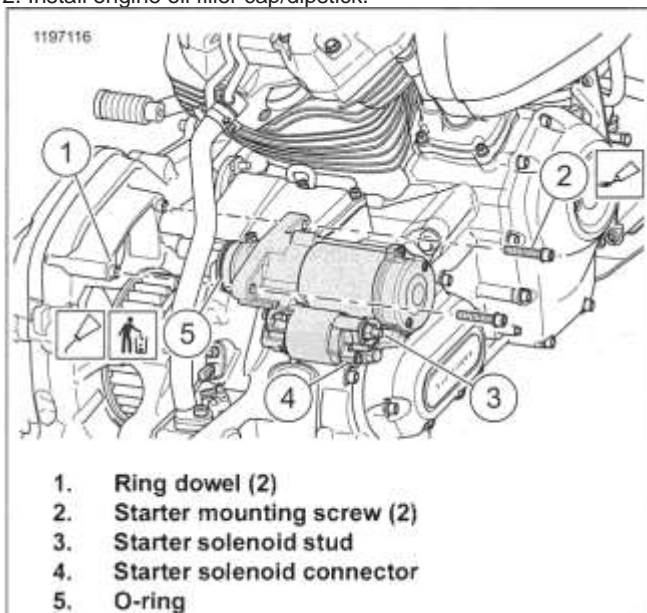


Figure 8-5. Starter

## COMPLETE

1. Connect negative battery cable. See POWER DISCONNECT (Page 8-8)

## PREPARE

1. Remove seat. See SEAT (Page 3-148)
2. Disconnect negative battery cable. See POWER DISCONNECT (Page 8-8)
3. Remove left passenger footboard and bracket as an assembly. See PASSENGER FOOTRESTS (Page 3-144)
4. Remove left rider footboard and brackets as an assembly. See RIDER FOOTRESTS (Page 3-142)
5. Remove starter. See STARTER (Page 8-11)
6. Drain primary chaincase. See REPLACE PRIMARY CHAINCASE LUBRICANT (Page 2-11)
7. Remove primary chaincase cover. See PRIMARY CHAINCASE COVER (Page 5-14)
8. Remove primary chain, clutch and compensating sprocket. See DRIVE COMPONENTS (Page 5-16)
9. Remove primary chaincase housing. See PRIMARY CHAINCASE HOUSING (Page 5-25)

## REMOVE

| PART NUMBER | TOOL NAME                              |
|-------------|--|
| HD-520 73   | ALTERNATOR ROTOR REMOVER AND INSTALLER |

Disconnect connector (5) from voltage

1. See Figure 8-6. regulator.

### A CAUTION

The high-output rotor contains powerful magnets. Exercise caution to prevent possible hand injury during removal and installation. (00558b)

2. Remove rotor (4).  
Special Tool: ALTERNATOR ROTOR REMOVER AND INSTALLER (HD-52073)
3. See Figure 8-7. Discard cable strap.  
*NOTE*  
*The rubber molded stator connector (5) is not serviceable.*
4. See Figure 8-6. Discard screws (2).
5. See Figure 8-8. Remove grommet (2).
  - a. Use the end of an awl or small screwdriver to move grommet (1) away from crankcase (2).
  - b. Spray isopropyl alcohol or glass cleaner into opening.

- c. Repeat this step at one or two other locations around grommet.
- d. Push grommet from outside of crankcase while pulling through the bore with needle nose pliers.

### NOTE

**Do not** pull stator wiring unless the stator is being replaced.

6. Remove stator assembly.

| PART NUMBER | TOOL NAME                              |
|-------------|--|
| HD-52073    | ALTERNATOR ROTOR REMOVER AND INSTALLER |

| FASTENER               | TORQUE VALUE |             |
|------------------------|--------------|-------------|
| Stator mounting screws | 55-75 in-lbs | 6.2-8.5 N-m |

| PART NUMBER | CONSUMABLE                   |
|-------------|------------------------------|
| 11300004    | ELECTRICAL CONTACT LUBRICANT |

1. Install grommet.

## INSTALL

- a. Clean the ribs of the grommet of all dirt and oil residue.
- b. Lubricate parts with glass cleaner or isopropyl alcohol.
- c. Route stator harness through hole from inside crankcase.
- d. Push grommet into crankcase bore while carefully pulling on outside cable.
- e. Installation is complete when cable stop contacts casting and capped rib of grommet exits crankcase bore.

### NOTE

*Do not reuse stator mounting screws.*

2. See Figure 8-6. Secure stator to crankcase using new screws (2). Tighten.  
Torque: 55-75 in-lbs (6.2-8.5 N-m) *Stator mounting screws*
3. See Figure 8-7. Secure stator wiring (2) to frame with new cable strap (1). Verify that stator wire does not contact the engine.
4. Apply dielectric grease to connector.  
Consumable: ELECTRICAL CONTACT LUBRICANT (11300004)
5. Install connector to voltage regulator. Engage locking latch.

### NOTE

*Install rotor slowly to prevent damaging rotor magnets. Damaged magnet fragments can damage the stator.*

## A CAUTION

The high-output rotor contains powerful magnets. Exercise caution to prevent possible hand injury during removal and installation. (00558b)

### 6. Install rotor.

Special Tool: ALTERNATOR ROTOR REMOVER AND INSTALLER (HD-52073)

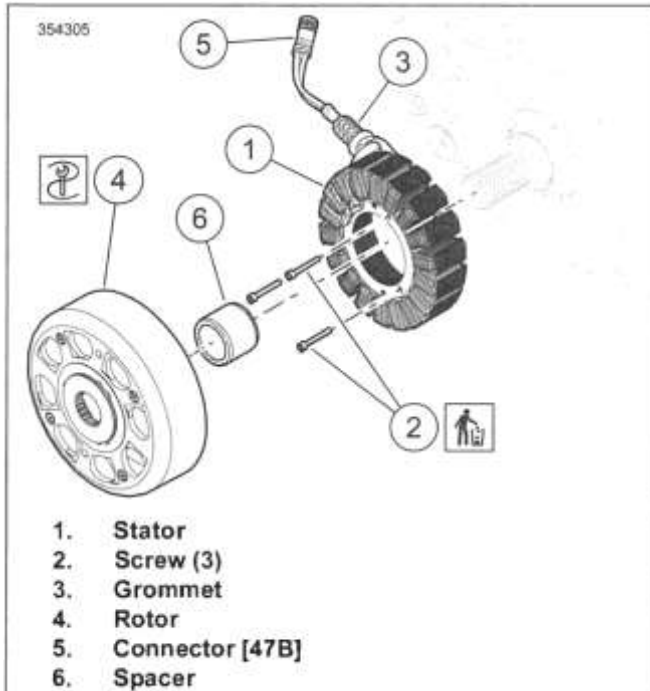


Figure 8-6. Rotor and Stator

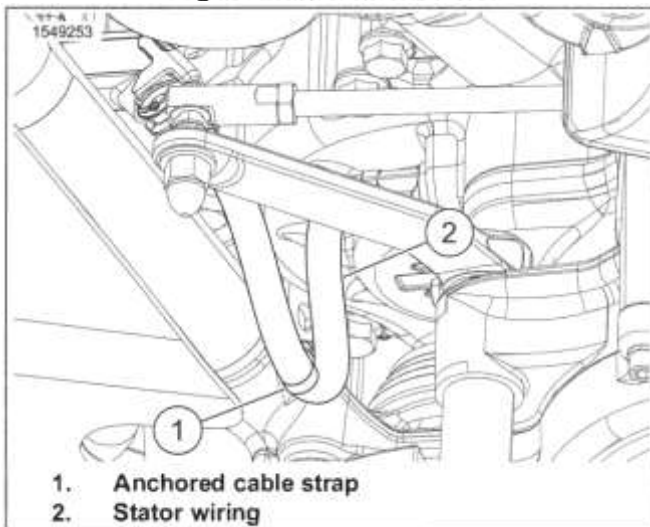


Figure 8-7. Stator Wiring

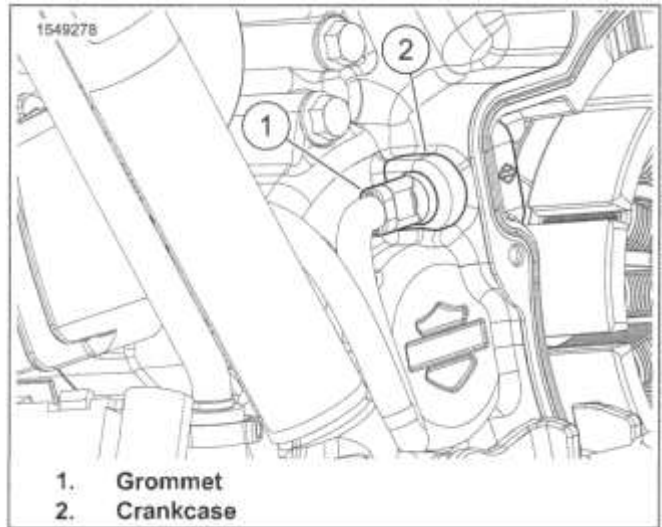


Figure 8-8. Remove Grommet From Crankcase (Typical)  
**COMPLETE**

1. Install primary chaincase housing. See PRIMARY CHAINCASE HOUSING (Page 5-25)
2. Install primary chain, clutch and compensating sprocket. See DRIVE COMPONENTS (Page 5-16)
3. Install primary chaincase cover. See PRIMARY CHAINCASE COVER (Page 5-14)
4. Fill primary chaincase. See REPLACE PRIMARY CHAINCASE LUBRICANT (Page 2-11)
5. Install starter. See STARTER (Page 8-11)
6. Install Remove left rider footboard and brackets as an assembly. See RIDER FOOTRESTS (Page 3-142)
7. Remove left passenger footboard and bracket as an assembly. See PASSENGER FOOTRESTS (Page 3-144)
8. Disconnect negative battery cable. See POWER DISCONNECT (Page 8-8)
9. Install seat. See SEAT (Page 3-148)

## PREPARE

1. Remove left side cover. See LEFT SIDE COVER (Page 3-62)
2. Remove main fuse. See POWER DISCONNECT (Page 8-8)

## REMOVE

1. Release downtube assembly.
  - a. Remove lower cover.
  - b. Release locking latch. Disconnect stator connector from regulator.
  - c. See Figure 8-9. Remove screws (2, 3) securing coolant downtubes.
  - d. Disconnect upper hoses from downtubes.
  - e. Pull top of downtube assembly away from frame to gain access to screws and connector.
2. Remove regulator.
  - a. Release voltage regulator cable from anchored cable clip (4).
  - b. Release locking latch. Disconnect voltage regulator connector.
  - c. Remove screws (1).
  - d. Remove regulator from downtube assembly.

## INSTALL

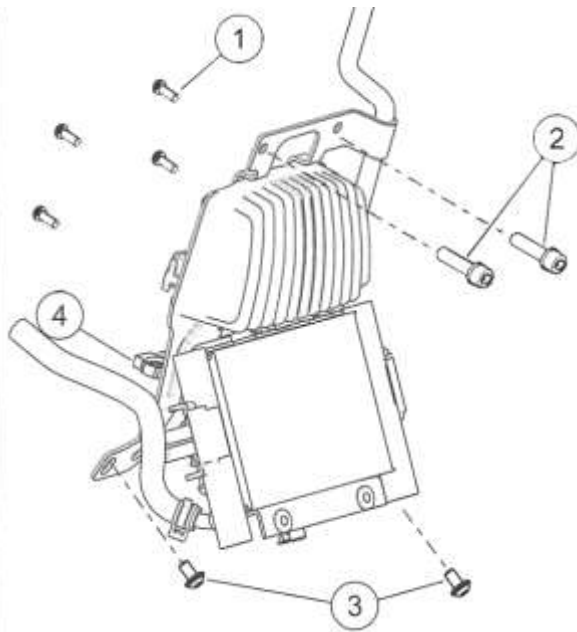
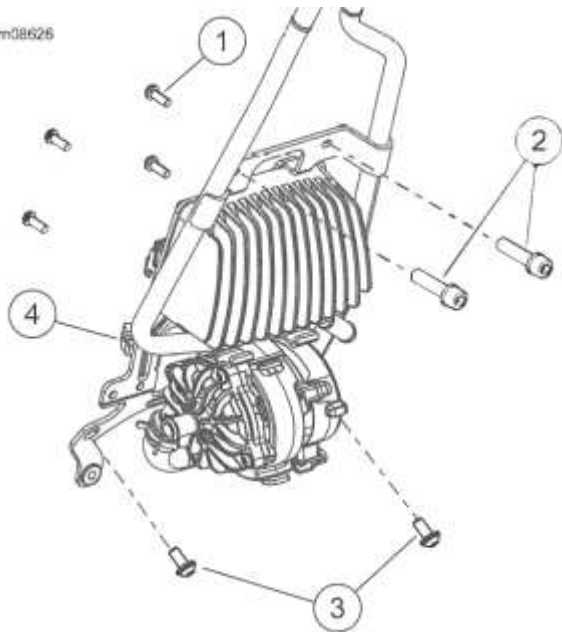
| FASTENER                      | TORQUE VALUE  |               |
|-------------------------------|---------------|---------------|
| Coolant downtube lower screws | 20-22 ft-lbs  | 27.1-29.8 N-m |
| Coolant downtube upper screws | 90-110 in-lbs | 10.2-12.4 N-m |

| FASTENER                 | TORQUE VALUE  |               |
|--------------------------|---------------|---------------|
| Voltage regulator screws | 96-120 in-lbs | 10.8-13.6 N-m |

| PART NUMBER | CONSUMABLE                   |
|-------------|------------------------------|
| 11300004    | ELECTRICAL CONTACT LUBRICANT |

1. See Figure 8-9. Install voltage regulator.
  - a. Apply dielectric grease to voltage regulator connector.  
ELECTRICAL CONTACT LUBRICANT (11300004)
  - b. Pull downtube assembly away from frame to access screws securing voltage regulator.
  - c. Install voltage regulator with screws (1). Tighten to 96-120 in-lbs (10.8-13.6 N-m).
  - d. Install voltage regulator connector. Secure connector with locking latch.
  - e. Secure voltage regulator cable with anchored cable clip (4).
2. Secure downtube assembly.
  - a. Install upper screws (2). Tighten to .  
Torque: 90-110 in-lbs (10.2-12.4 N-m) *Coolant downtube upper screws*
  - b. Install lower screws (3). Tighten.  
Torque: 20-22 ft-lbs (27.1-29.8 N-m) *Coolant downtube lower screws*
  - c. Apply silicone-based dielectric grease to stator connector.
  - d. Connect stator connector. Secure connector with locking latch.
  - e. Install lower cover.





**Figure 8-9. Voltage Regulator (Typical)**  
 1. Voltage regulator screws (4)

- 3. Lower screw (2)
- 4. Anchored cable clip

**COMPLETE**

- 2. Upper screw (2)
- 3. **Air-Cooled:** Perform oil level hot check. See REPLACE ENGINE OIL AND FILTER (Page 2-9)
- 1. Install main fuse. See POWER DISCONNECT (Page 8-8)
- 2. Install left side cover. See LEFT SIDE COVER (Page 3-62)
- 4. **Twin-Cooled:** Check coolant level after first heat and cool cycle. See COOLANT (Page 7-8)

1. Remove left side cover. See LEFT SIDE COVER (Page 3-62)
2. Remove main fuse. See POWER DISCONNECT (Page 8-8)
3. Non-Fairing Models: Remove seat. See SEAT (Page 3-148)
4. Non-Fairing Models: Remove console. See CONSOLE (Page 6-5)

## REMOVE AND INSTALL: FAIRING MODELS

### Remove

1. *NOTE*

| PART NUMBER | TOOL NAME                      |
|-------------|--------------------------------|
| HD-51198    | IGNITION SWITCH ALIGNMENT TOOL |

| FASTENER  | TORQUE VALUE  |            |
|---|---------------|------------|
| Ignition switch housing screws:<br>Fairing models | 85-115 in-lbs | 9.6-13 N-m |

Use *IGNITION SWITCH ALIGNMENT TOOL (PART NUMBER: HD-51198)* to move the switch to other positions as required.

See Figure 8-10. Remove the ignition switch knob.

- a. Insert ignition switch key and turn to the UNLOCK position. Leave key installed.
- b. Rotate the knob to FORK LOCK.
- c. Press and hold the release button at bottom (left side) of the knob, and turn key 60° counterclockwise.
- d. Lift knob to remove.

#### *NOTE*

*Spring will drop out of bore at underside of knob when removed.*

2. Fork mounted fairing models: Remove dash panel. See FAIRING: FORK MOUNTED (Page 3-89)
3. Frame mounted fairing models: Remove instrument bezel. See FAIRING: FRAME MOUNTED (Page 3-100)
4. Disconnect ignition switch connector.
5. Remove two screws and flat washers securing ignition switch assembly.
6. Remove ignition switch.

### Install

1. Place ignition switch into position.

#### *NOTE*

- *Inspect the shape of the lock pin to verify it is the correct shape for the vehicle prior to installing the new ignition switch.*
- *See Figure 8-11. 2-wheel vehicles (1) have a pin that is round at the end. Trike models (2) have a pin that is ellipse-shaped. The 2-wheel style will not function if installed on a Trike. A Trike style will function on a 2-wheel vehicle however, excess steering rotation will result in the locked position.*

2. Install two screws and flat washers. Tighten.

Torque: 85-115 in-lbs (9.6-13 N-m) *Ignition switch housing screws: Fairing models*

3. Install ignition switch connector.
4. Fork mounted fairing models: Install dash panel. See FAIRING: FORK MOUNTED (Page 3-89)
5. Frame mounted fairing models: Install instrument bezel. See FAIRING: FRAME MOUNTED (Page 3-100)
6. Place spring into bore at underside of knob.
7. Install ignition switch knob.
  - a. See Figure 8-10. Verify that button at bottom of knob is pressed and key is turned 60° counterclockwise of the UNLOCK position.
  - b. With the knob pointing toward the FORK LOCK position, insert shaft into ignition switch.
  - c. Hold the knob down and the turn key clockwise to the UNLOCK position. An audible "click" is heard when knob and switch are properly engaged.
  - d. Release the knob. Rotate through all four switch positions to verify proper operation.

#### *NOTE*

*If knob does not install properly, Refer to Misaligned Switch. Refer to HEADLAMP.*

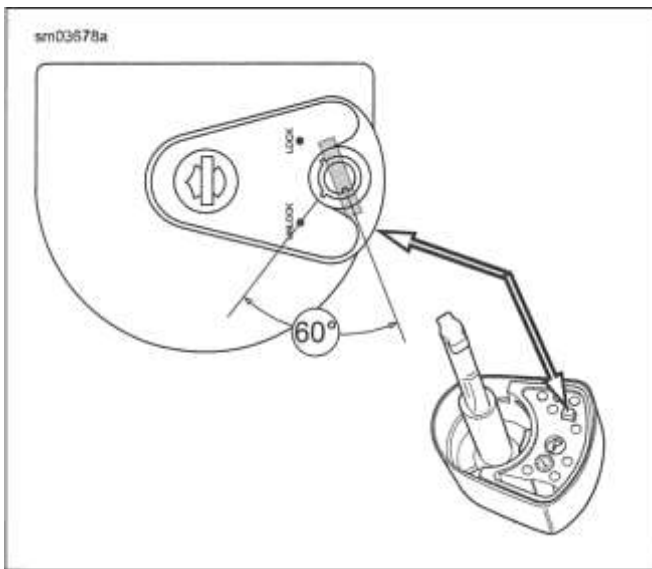


Figure 8-10. Ignition Switch Knob Release Button (Top and Bottom Views)

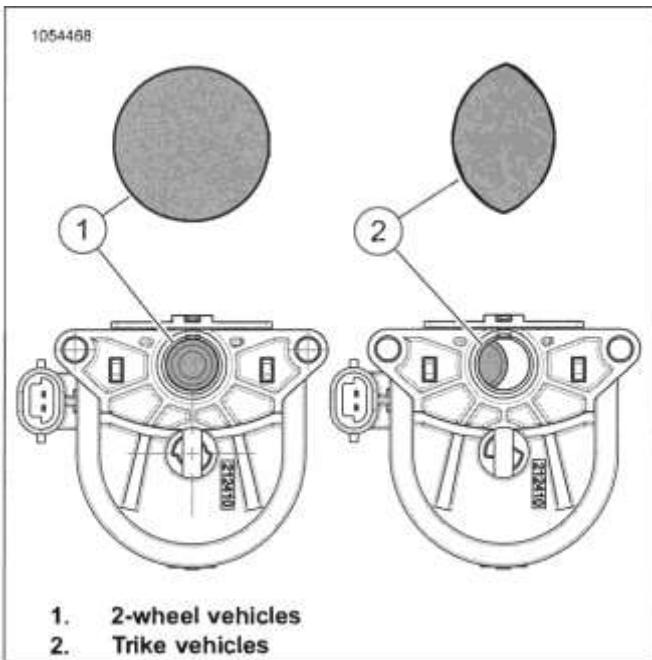


Figure 8-11. Fork Lock Pin

### Misaligned Switch

1. Insert alignment tool.
  - a. Insert tool until bottom of handle contacts top of ignition switch.
  - b. While holding front forks at the left fork stop, rotate handle of tool counterclockwise until fork locks.
2. Remove alignment tool.
3. Install knob.
  - a. Knob not installing properly. Go to next step.
  - b. Knob installed properly. Stop, installation completed.
4. Insert knob into ignition switch and

5. Rotate until it drops into the partially installed position.
  - a. After rotating, take note whether it is pointing toward the rear, or to ACCESS, IGNITION or OFF.
6. Remove knob.
7. Insert alignment tool.
  - a. Insert alignment tool.
  - b. Hold alignment tool so that the bottom of the handle is approximately 0.50-0.75 in (12.7-19.1 mm) from the top of the ignition switch.
8. Rotate alignment tool counterclockwise.
  - a. Rotate tool the number of positions needed to get to FORK LOCK.
9. Install knob.

### REMOVE AND INSTALL: NON-FAIRING MODELS

| FASTENER                          | TORQUE VALUE |             |
|-----------------------------------|--------------|-------------|
| Ignition switch screws: Road King | 25-35 in-lbs | 2.8-3.9 N-m |

#### Remove

1. See Figure 8-12. Disconnect ignition switch connector (1).
2. Release ignition switch conduit from plastic clip (3), if necessary.
3. Remove screws (2).
4. Remove ignition switch.

#### Install

1. See Figure 8-12. Install ignition switch with screws (2). Tighten in a cross-wise pattern.  
Torque: 25-35 in-lbs (2.8-3.9 N-m) *Ignition switch screws: Road King*
2. Connect ignition connector (1).
3. If removed, capture ignition switch conduit in plastic clip (3).

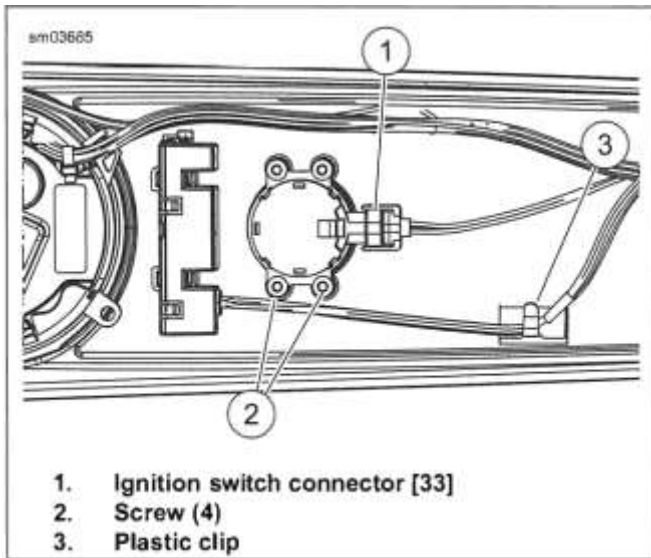


Figure 8-12. Instrument Console (Road King)

### **COMPLETE**

1. **Non-Fairing Models:** Install console. See CONSOLE (Page 6-5)
2. **Non-Fairing Models:** Install seat. See SEAT (Page 3-148)
3. Install main fuse. See POWER DISCONNECT (Page 8-8)
4. Install left side cover. See LEFT SIDE COVER (Page 3-62)

## PREPARE

1. Purge fuel line. See PURGE FUEL LINE (Page 6-7)
2. Disconnect fuel line from tank. See FUEL LINE (Page 6-8)
3. Remove left saddlebag. See SADDLEBAGS (Page 3-161)
4. Remove left side cover. See LEFT SIDE COVER (Page 3-62)
5. Remove main fuse. See POWER DISCONNECT (Page 8-8)
6. Remove seat. See SEAT (Page 3-148)
7. Remove fuel tank. See FUEL TANK (Page 6-10)

## REMOVE

**NOTE**

Verify and note plug cable routing. Route new cables the same

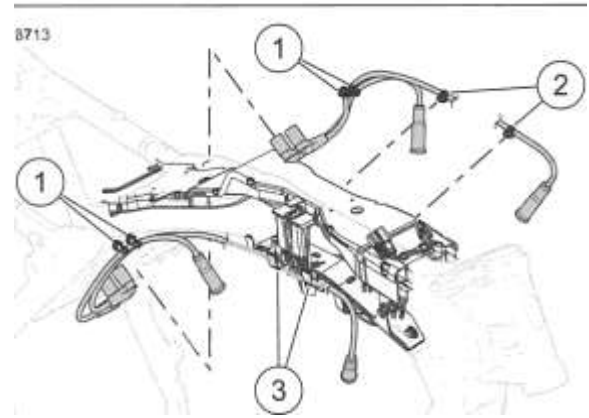
| PART NUMBER | TOOL NAME                         |
|-------------|-----------------------------------|
| HD-52006    | ADJUSTABLE SPARK PLUG WIRE PULLER |

way

1. Remove cables from ignition coil.
2. Release cables retainers.
3. Using the wire puller, remove boots from spark plugs.  
Special Tool: ADJUSTABLE SPARK PLUG WIRE PULLER (HD-52006)

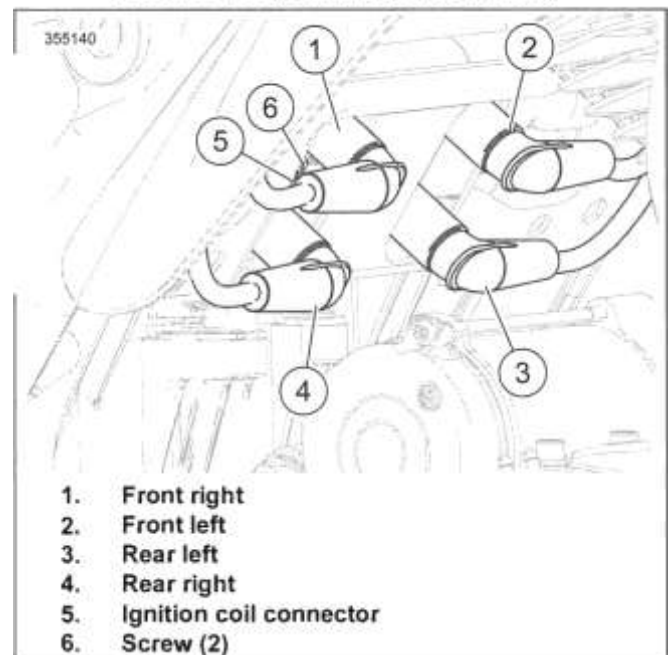
## INSTALL

1. See Figure 8-13. Connect long cables to front spark plugs.
2. Connect short cables to rear spark plugs.
3. Adjust spark plug boots to avoid contact with fuel tank.
4. **Right cables:** Secure cable straps (1). Route front cable through caddy retainers (3).
5. **Left cables:** Secure left side anchored cable straps (2) to frame backbone.
6. See Figure 8-14. Connect cables to ignition coil.



1. Anchored cable straps
2. Left side anchored cable straps
3. Caddy retainers

Figure 8-13. Spark Plug Cable Routing



1. Front right
2. Front left
3. Rear left
4. Rear right
5. Ignition coil connector
6. Screw (2)

Figure 8-14. Ignition Coil Connections

## COMPLETE

1. Install fuel tank. See FUEL TANK (Page 6-10)
2. Connect fuel line to tank. See FUEL LINE (Page 6-8)
3. Install console. See CONSOLE (Page 6-5)
4. Install seat. See SEAT (Page 3-148)
5. Install main fuse. See POWER DISCONNECT (Page 8-8)
6. Install left side cover. See LEFT SIDE COVER (Page 3-62)
7. Install left saddlebag. See SADDLEBAGS (Page 3-161)

## PREPARE

1. Remove left saddlebag. See SADDLEBAGS (Page 3-161).
2. Remove left side cover. See LEFT SIDE COVER (Page 3-62).
3. Remove main fuse. See POWER DISCONNECT (Page 8-8).
4. Remove seat. See SEAT (Page 3-148)
5. Remove top caddy. See TOP CADDY (Page 8-107).
6. Remove battery. See INSPECT BATTERY (Page 2-48)

## REMOVE

1. See Figure 8-16. Remove spark plug wires (1-4) from ignition coil towers.
2. Remove ignition coil connector (5).
3. See Figure 8-17. Remove screws (2).
4. Loosen ground terminal nut (4).
5. Hold ground terminal wires out of the way.
6. Remove battery hold-down bracket (3) and ignition coil (1).
7. See Figure 8-15. Remove screws (3) and ignition coil (2).

## INSTALL

1. See Figure 8-15. Install screws (3) through ignition coil (2) into battery hold-down bracket (1). Tighten.  
Torque: 32-40 in-lbs (3.6-4.5 N-m) *Ignition coil screws*

| FASTENER                       | TORQUE VALUE |              |
|--------------------------------|--------------|--------------|
| Battery hold-down screws       | 32-40 in-lbs | 3.6-4.5 N-m  |
| Harness ground stud flange nut | 50-90 in-lbs | 5.7-10.2 N-m |
| Ignition coil screws           | 32-40 in-lbs | 3.6-4.5 N-m  |

6. See Figure 8-16. Install ignition coil connector (5).
7. Connect spark plug wires (1-4) to ignition coil towers.

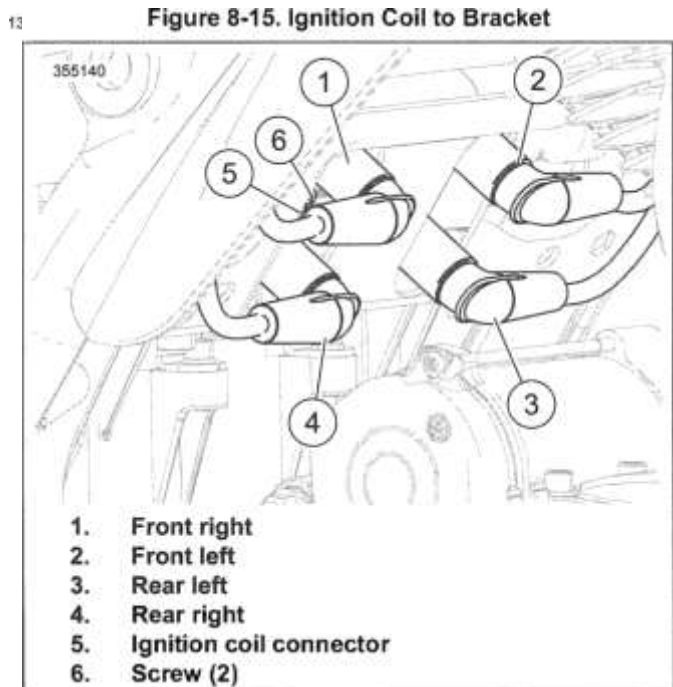


Figure 8-16. Ignition Coil Connections

2. Hold ground terminal wires out of the way.
3. See Figure 8-17. Place ignition coil (1) and battery hold-down bracket (3) into position.
4. Install screws (2). Tighten.  
Torque: 32-40 in-lbs (3.6-4.5 N-m) *Battery hold-down screws*
5. Tighten ground terminal nut (4).  
Torque: 50-90 in-lbs (5.7-10.2 N-m) *Harness ground stud flange nut*

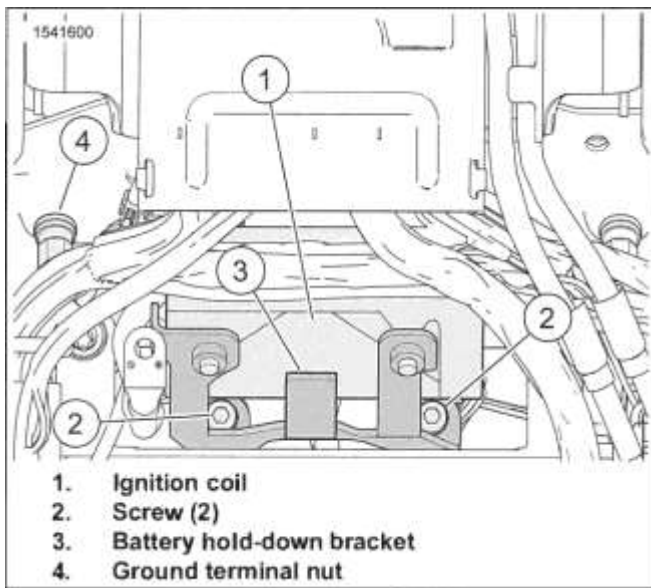


Figure 8-17. Ignition Coil Mount

## **COMPLETE**

1. Install battery. See INSPECT BATTERY (Page 2-48)
2. Install top caddy. See TOP CADDY (Page 8-107).
3. Install seat. See SEAT (Page 3-148)
4. Install main fuse. See POWER DISCONNECT (Page 8-8).
5. Install left side cover. See LEFT SIDE COVER (Page 3-62).
6. Install left saddlebag. See SADDLEBAGS (Page 3-161).

**PREPARE**

1. Remove left side cover. See LEFT SIDE COVER (Page 3-62)
2. Remove main fuse. See POWER DISCONNECT (Page 8-8)
3. FLHRXS: Remove turn signal lamp and mirror. See MIRRORS (Page 3-132)
4. Remove clutch handle assembly. See CLUTCH CONTROL (Page 3-81)

**REMOVE**

1. See Figure 8-21. Remove trigger finger switch cap (1).

**NOTE**

To replace the hand control module harnesses on internally wired handlebar, see HANDLEBAR (Page 3-125)

- a. Lightly lift trigger finger switch cap away from LHCM to elevate from normal position.
  - b. See Figure 8-18. Using a small screwdriver, carefully pry between trigger finger switch cap and switch plunger..
  - c. Slide trigger finger switch cap off in direction shown.
2. See Figure 8-19. Remove Left Hand Control Module (LHCM) housing (6).

**NOTE**

The LHCM housing screws (5) are captive.

- a. Loosen screws (5).
  - b. Remove front housing (6).
3. See Figure 8-20. Remove connectors.

**NOTE**

The latches on connectors are fragile. Use care when disconnecting.

- a. Using a pick, carefully press connector latch down.
  - b. Use a prying motion on latch while pulling on connector to remove.
4. FLHRXS: Disconnect turn signal lamp.
  5. See Figure 8-19. Release connector latch (2) and rotate switch (1) down.
  6. Remove hand control module.
    - a. Remove hand control module from handlebar.
    - b. Release wires from hand control module.
    - c. Remove hand control module.

**INSTALL**

| FASTENER            | TORQUE VALUE |         |
|---------------------|--------------|---------|
| LHCM housing screw. | 35-44 in-lbs | 4-5 N-m |

1. See Figure 8-19. Connect LHCM connector (3).

**NOTE**

Never install a switch from a different model. Although they are similar and will physically install, certain features are different and will cause the clutch interlock to not operate properly

- a. Route harness through fingers (4) and into channel in control module.
  - b. Connect LHCM connectors.
2. See Figure 8-19. Install LHCM on handlebar.
    - a. Rotate switch (1) up and snap latch (2) into place.

**NOTE**

Avoid pinching wires by alignment finger (4) while assembling switch housings.

3. See Figure 8-20. Route wires close to the wire retainer (2).
4. Verify that wire harness is in the recess at bottom of handlebar.
5. FLHRXS: Connect turn signal lamp.
6. See Figure 8-19. Install front housing.
  - a. Align switch housing on LHCM.
  - b. Install screws (5) until snug.
7. Install clutch control assembly. See CLUTCH CONTROL (Page 3-81)
8. Tighten screws.
 

Torque: 35-44 in-lbs (4-5 N-m) LHCM housing screw.

**NOTE**

A click may be heard when switch cap is properly installed.

See Figure 8-21. Install trigger finger switch cap (1).

- a. Raise switch to elevated position.
- b. See Figure 8-22. Slide switch cap onto switch until fully seated.
- c. Press switch cap into normal position.



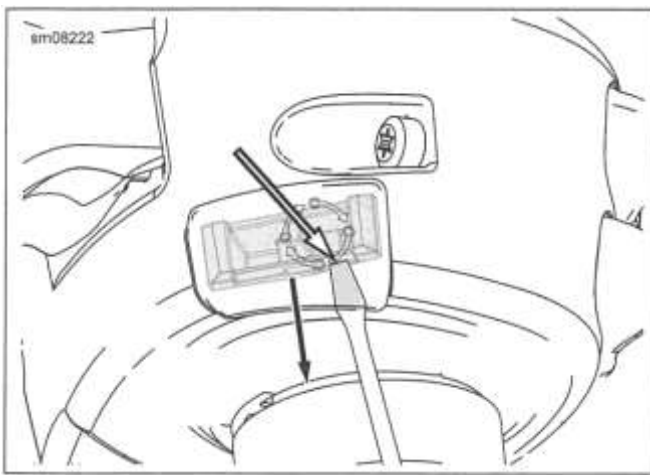
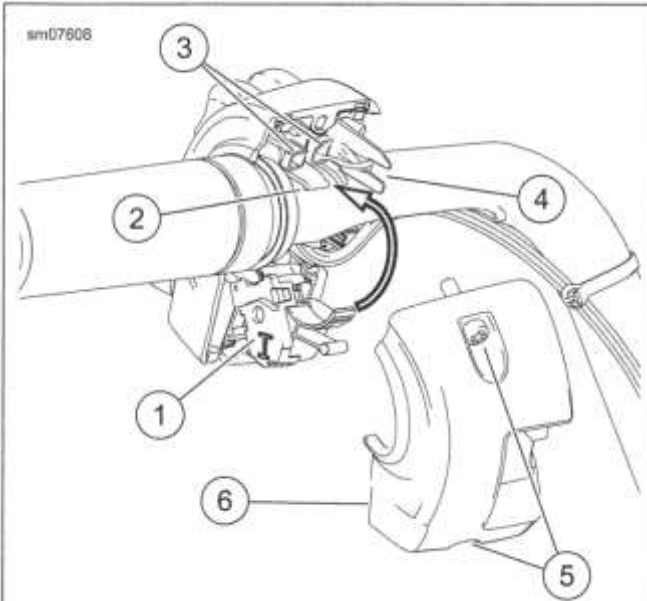
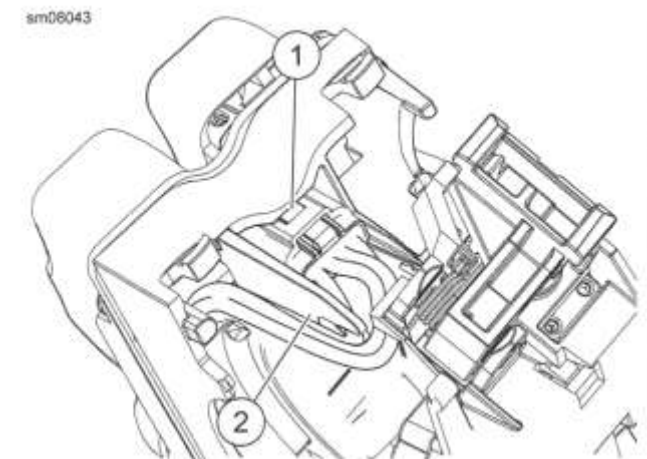


Figure 8-18. Slide off Trigger Finger Switch Cap



1. Switch
2. Latch
3. Connectors
4. Fingers
5. Screws
6. Front housing

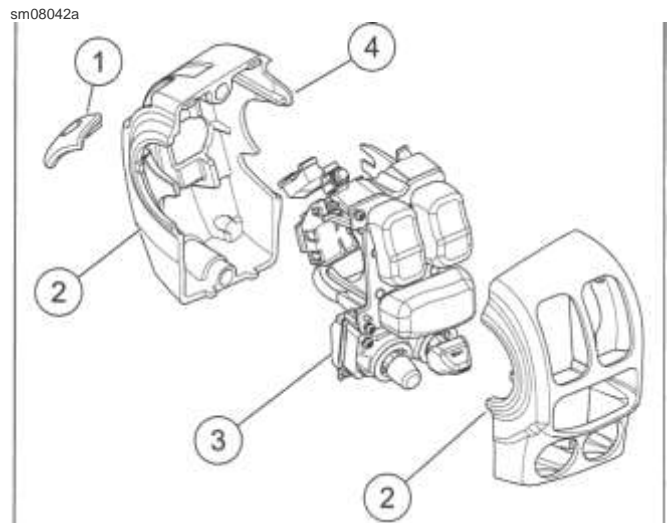
Figure 8-19. Hand Control Module (Typical)



1. Connector latch
2. Fingers

Figure 8-20. LHCM Connector (Typical)

## Rocker Switch Caps



1. Trigger finger switch cap
2. Housings
3. LHCM
4. Alignment feature

Figure 8-21. LHCM (typical): Left Side Shown

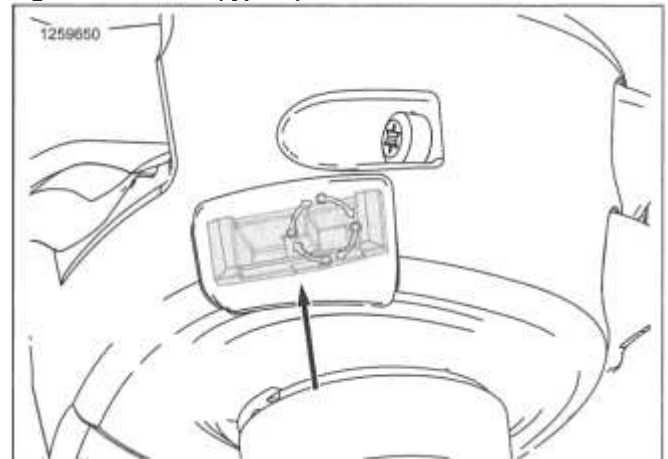


Figure 8-22. Slide Trigger Finger Switch Cap On

## SWITCH CAPS

1. Remove handlebar switch housing.

2. **NOTE**

*There are small pins and springs under some caps. Springs and pins could be lost during cap removal or installation.*

Remove switch cap.

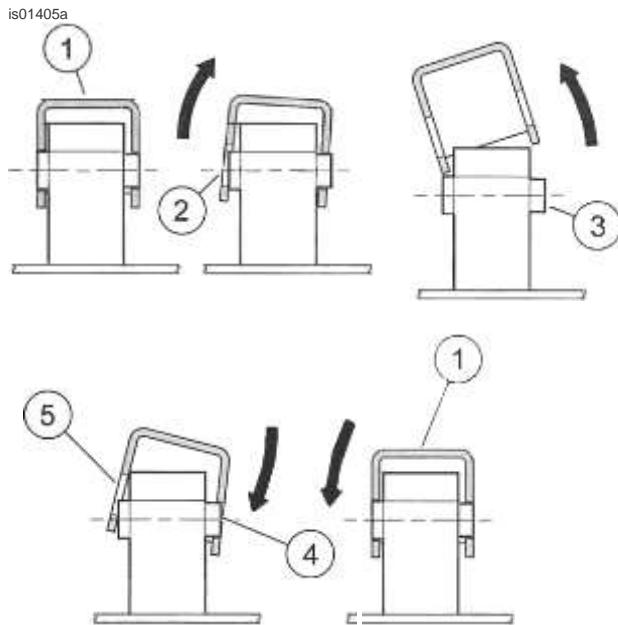
- a. See Figure 8-23. Carefully pry switch cap up off pin (2) on side of switch.
- b. Pry switch cap up and away from pin (3) on opposite side.

3. Install switch cap.

- a. Place cap onto switch, angling hole over pin (4).

- b. Carefully press switch cap down onto opposite pin (5), rocking cap until snapping into place.

4. Verify proper operation.
5. Install switch housing.

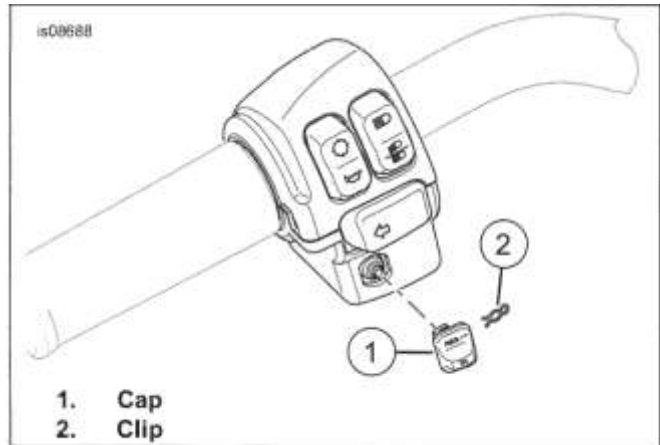


1. **Switch cap installed correctly**
  2. **Switch cap removal from shaft**
  3. **Switch cap removal from pivot pin**
  4. **Switch cap installation on to pivot pin**
  5. **Switch cap installation onto shaft**
- Figure 8-23. Switch Cap Removal and Replacement**

### Cruise Switch Cap

1. See Figure 8-24. Remove cap.
  - a. Remove clip (2).
  - b. Remove cap (1).

2. Install cap.
  - a. Install cap.
  - b. Install clip.
  - c. Verify cap is secure.



**Figure 8-24. Cruise Switch Cap**  
**CLUTCH SWITCH REPLACEMENT**

The clutch switch is not replaceable for Touring vehicles.

### **COMPLETE**

1. **FLHRXS:** Install mirror and turn signal lamp. See MIRRORS (Page 3-132)
2. Install main fuse. See POWER DISCONNECT (Page 8-8)
3. Install left side cover. See LEFT SIDE COVER (Page 3-62)

### **A WARNING**

**Be sure that all lights and switches operate properly before operating motorcycle. Low visibility of rider can result in death or serious injury. (00316a)**

4. Test switches for proper operation.

## PREPARE

1. Remove left side cover. See LEFT SIDE COVER (Page 3-62).
2. Remove main fuse. See POWER DISCONNECT (Page 8-8).
3. FLHRXS: Remove turn signal lamp and mirror. See MIRRORS (Page 3-132).
4. Without draining brake fluid, remove brake hand control assembly. See FRONT BRAKE MASTER CYLINDER (Page 3-37).

## REMOVE

1. See Figure 8-25. Remove housing.

### NOTE

- To replace the hand control module harnesses on internally wired handlebar, see HANDLEBAR (Page 3-125)
- The screws (5) are captive.
  - a. Loosen screws (5).
  - b. Remove front housing (6).

2. See Figure 8-26. Remove connectors.

### NOTE

The latches on connectors are fragile. Use care when disconnecting.

- a. Using a pick, carefully press connector latch (1) down.
  - b. Use a prying motion on latch while pulling on connector to remove.
3. FLHRXS: Disconnect turn signal lamp.
  4. See Figure 8-25. Release connector latch (2) and rotate switch (1) down.
  5. Remove hand control module.
    - a. Remove hand control module from handlebar.
    - b. Release wires from hand control module.
    - c. Remove hand control module.

## INSTALL

1. Install throttle hand grip.
  - a. Verify TGS is fully engaged in slots in handlebar.
  - b. Rotate hand grip until cosmetic features are properly aligned.
  - c. Engage hand grip on TGS splines.
  - d. Heated hand grips: Connect electrical connector. See HAND GRIPS (Page 3-123)
2. Attach harness connectors to RCHM.
  - a. Place harness into channel of front RHCM housing.
  - b. See Figure 8-25. Route harness through fingers (4).
  - c. Connect electrical connectors (3).
3. NOTE  
Avoid pinching wires by alignment finger (4) while assembling switch housings.  
  
See Figure 8-25. Install RHCM on handlebar.
  - a. Rotate arm of switch (1) up until it attaches to latch (2).
4. Verify that wire harness is in the recess at bottom of handlebar.
5. FLHRXS: Connect turn signal lamp.
6. See Figure 8-25. Install front and rear RHCM switch housings.
  - a. Install switch housings on RHCM.
  - b. Install screws (5). Tighten finger tight.
7. Set right hand grip end play.
  - a. Move RHCM assembly inboard to remove grip end play.
  - b. Move switch housing outboard to specification.
    0. 039-0.079 in (1-2 mm)
8. Tighten RHCM housing screws.  
Torque: 35-44 in-lbs (4-5 N-m) RHCM housing screw
9. Verify right hand grip has slight inboard-outboard movement.
10. Verify right hand grip rotates and returns freely.

| FASTENER           | TORQUE VALUE |         |
|--------------------|--------------|---------|
| RHCM housing screw | 35-44 in-lbs | 4-5 N-m |

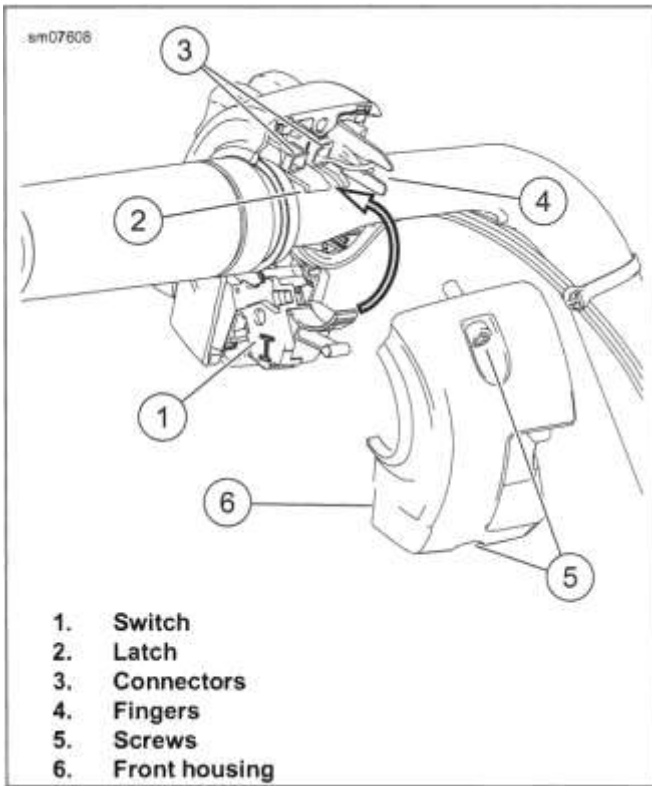


Figure 8-25. Hand Control Module (Typical)

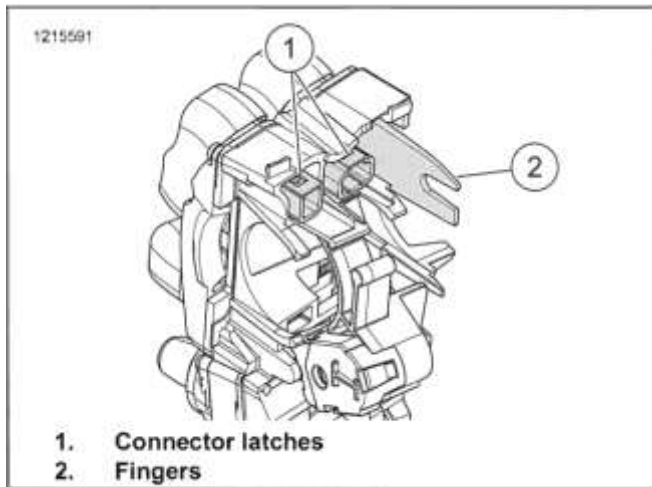


Figure 8-26. RHCM Connectors

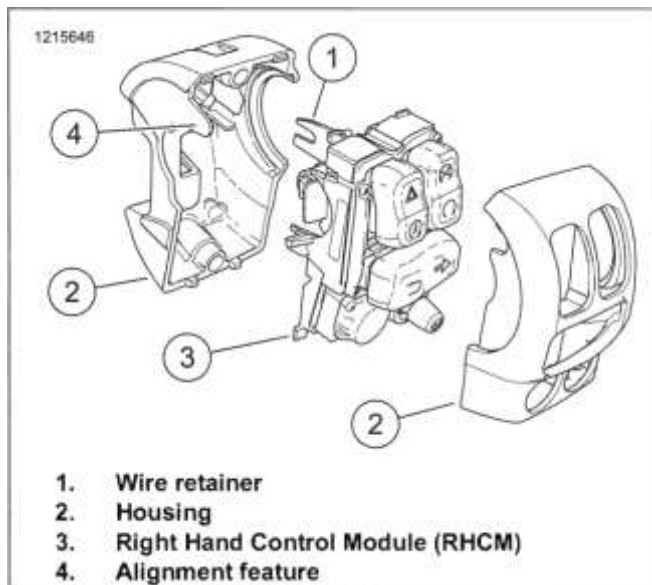


Figure 8-27. RHCM (Typical)

## SWITCH CAPS

### Rocker Switch Caps

1. Remove handlebar switch housing.

2. **NOTE**  
There are small pins and springs under some caps. Springs and pins could be lost during cap removal or installation.

Remove switch cap.

- a. See Figure 8-28. Carefully pry switch cap up off pin (2) on side of switch.
- b. Pry switch cap up and away from pin (3) on opposite side.

3. Install switch cap.

- a. Place cap onto switch, angling hole over pin (4).
- b. Carefully press switch cap down onto opposite pin (5), rocking cap until snapping into place.

4. Verify proper operation.

5. Install switch housing.

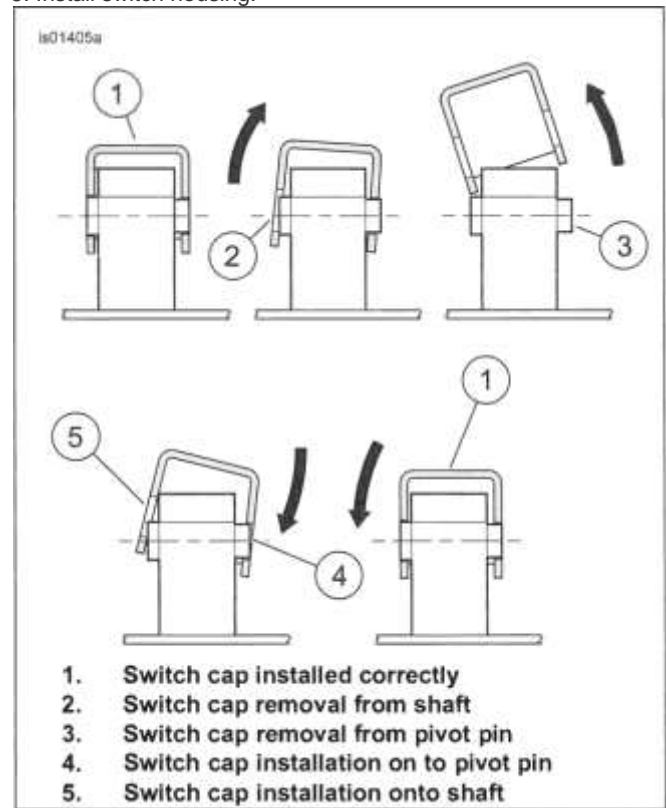


Figure 8-28. Switch Cap Removal and Replacement

### Toggle and Joystick Caps Remove

1. Grasp with pliers and pull cap straight off, discard.

*NOTE*

*Removal will destroy cap.*

**Install**

1. Push **new** cap straight on with finger.

**FRONT BRAKE SWITCH REPLACEMENT**

The front brake switch is not replaceable for Touring vehicles.

**COMPLETE** \_\_\_\_\_

1. Install brake hand control assembly. See FRONT BRAKE CALIPER (Page 3-40)
2. **FLHRXS:** Install mirror and turn signal lamp. See MIRRORS (Page 3-132)
3. Install main fuse. See POWER DISCONNECT (Page 8-8)
4. Install left side cover. See LEFT SIDE COVER (Page 3-62)

**A WARNING**

**Be sure that all lights and switches operate properly before operating motorcycle. Low visibility of rider can result in death or serious injury. (00316a)**

5. Test switches for proper operation.

## PREPARE

1. Remove left side cove. See LEFT SIDE COVER (Page 3-62)
2. Remove main fuse. See POWER DISCONNECT (Page 8-8)
3. **Fork-mounted fairing models:** Remove dash panel. See FAIRING: FORK MOUNTED (Page 3-89)
4. **Frame-mounted fairing models:** Remove instrument bezel. See FAIRING: FRAME MOUNTED (Page 3-100)
5. **Nacelle mounted models:** Remove nacelle half containing switch. See HEADLAMP NACELLE (Page 3-87)

## REMOVE AND INSTALL: FORK MOUNTED FAIRING

### Remove

| FASTENER                      | TORQUE VALUE |            |
|-------------------------------|--------------|------------|
| Accessory switch module screw | 12-17in-lbs  | 1.4-1.9N-m |

1. See Figure 8-29. Remove switch module (2) or hole plug (1).

*NOTE*

Maximum current rating for each switch is 2 A.

- a. Remove screws (3).
  - b. Remove switch module or hole plug.
2. See Figure 8-30. Release lock (3).
 

*NOTE*

    - Record positions of switches and plunger types for assembly
    - The switch module assembly can house either active switch plungers or static plungers depending on equipment. Active plungers can be push-push type or momentary. All are removed and installed in the same manner.
    - Lock (3) extracts approximately 3/8 in (3.2 mm) and does not come free from housing.
      - a. Gently pry lock outward to release switch plunger (2).
  3. Remove switch plunger from switch module (1).

### Install

1. See Figure 8-30. Install switch plunger (2).

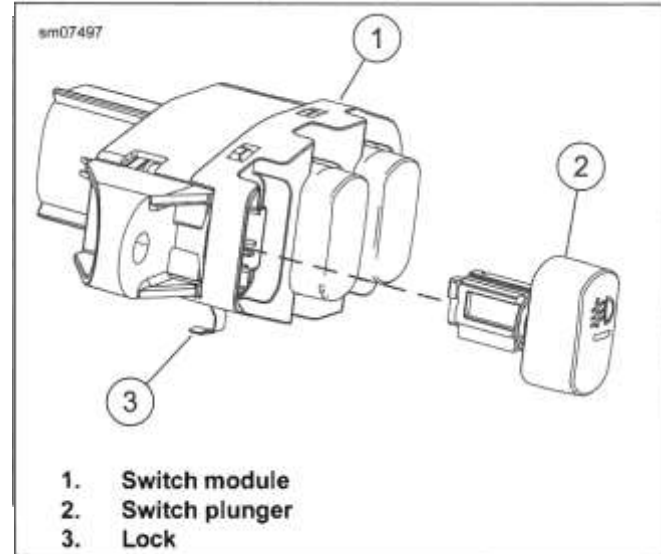
*NOTE*

Verify that switches are located as recorded during disassembly

- a. Push plunger into switch module (1).
  - b. Push lock (3) into place.
2. See Figure 8-29. Install switch module (2).
    - a.
    - b. Align switch module to dash panel.
    - b. Install screws (3). Tighten.

Torque: 12-17 **in-lbs** (1.4-1.9 N-m) Accessory, switch module screw

**Figure 8-29. Dash Panel Switches**



1. Switch module
2. Switch plunger
3. Lock

**Figure 8-30. Switch Module Components**

## REMOVE AND INSTALL: FRAME MOUNTED FAIRING

### Remove

1. See Figure 8-31. Remove switch module (2) or hole plug (1).

| FASTENER                      | TORQUE VALUE |            |
|-------------------------------|--------------|------------|
| Accessory switch module screw | 12-17in-lbs  | 1.4-1.9N-m |

**NOTE**

Maximum current rating for each switch is 2 A.

- a. Remove screws (3).
  - b. Remove switch module or hole plug.
2. Release lock (3).

**NOTE**

- Record positions of switches and plunger types for assembly.
- The switch module assembly can house either active switch plungers or static plungers depending on equipment. Active plungers can be push-push type or momentary. All are removed and installed in the same manner.
- Lock (3) extracts approximately  $V_8$  in (3.2 mm) and does not come free from housing.

- a. Gently pry lock outward to release switch plunger (2).
3. Remove switch plunger from switch module (1).

**Install**

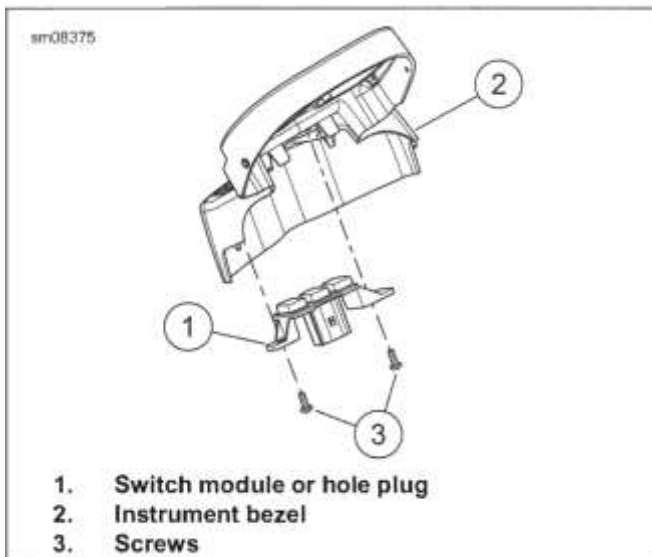
1. See Figure 8-31. Install switch plunger (2).

**NOTE**

Verify that switches are located as recorded during disassembly.

- a. Push plunger into switch module (1).
  - b. Push lock (3) into place.
2. Install switch module (2).
  - a. Align switch module to dash panel.
  - b. Install screws (3). Tighten.

Torque: 12-17 **in-lbs** (1.4-1.9 N-m) *Accessory switch module screw*



**Figure 8-31. Accessory Switches**

**REMOVE AND INSTALL: NACELLE MOUNTED**

| FASTENER               | TORQUE VALUE |           |
|------------------------|--------------|-----------|
| Nacelle switch hex nut | 9-15 in-lbs  | 1-1.7 N-m |

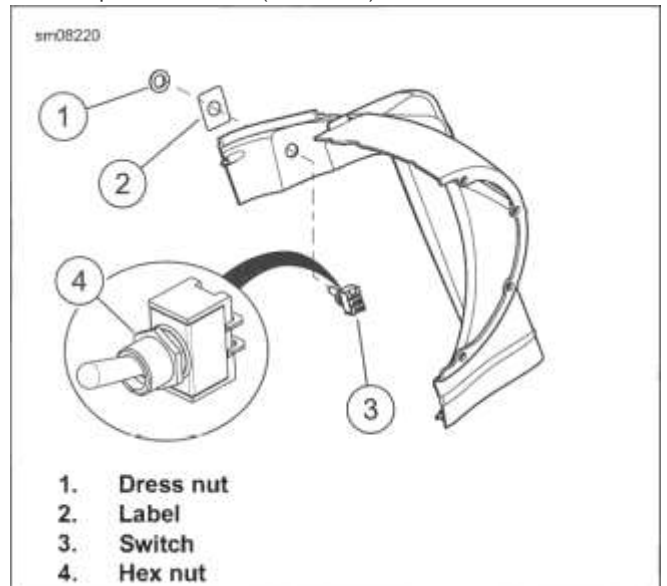
**Remove**

1. See Figure 8-32. Remove switch (3).
- a. Remove dress nut (1).
- b. Remove switch.

**Install**

1. See Figure 8-32. Install the switch.
  - a. Turn hex nut (4) down against switch body.
  - b. Verify label (2) is in place.
  - c. Put the switch (3) in place.
  - d. Install the dress nut (1) 1.5-2.5 turns.
2. Turn hex nut (4) against the inside of the nacelle. Tighten.
 

Torque: 9-15 **in-lbs** (1-1.7 N-m) *Nacelle switch hex nut*



**Figure 8-32. Nacelle Switch**

**COMPLETE**

1. **Nacelle mounted models:** Install nacelle half containing switch. See HEADLAMP NACELLE (Page 3-87)
2. **Frame-mounted fairing models:** Install instrument bezel. See FAIRING: FRAME MOUNTED (Page 3-100)
3. **Fork-mounted fairing models:** Install dash panel. See FAIRING: FORK MOUNTED (Page 3-89)
4. Install main fuse. See POWER DISCONNECT (Page 8-8)
5. Install left side cover. See LEFT SIDE COVER (Page 3-62)

6. Operate switches to verify repair.



**PREPARE**

1. Remove left saddlebag. See SADDLEBAGS (Page 3-161)
  2. Remove left side cover. See LEFT SIDE COVER (Page 3-62)
  3. Remove main fuse. See POWER DISCONNECT (Page 8-8)
  4. Fork-mounted fairing: See FAIRING: FORK MOUNTED (Page 3-89)
    - a. Remove outer fairing.
    - b. Remove fairing vent.
    - c. Remove fairing upper support bracket.
  5. Frame-mounted fairing: Remove ignition switch knob. See IGNITION SWITCH (Page 8-16)
  6. Non-fairing models:
    - a. Remove seat. See SEAT (Page 3-148)
    - b. Remove console. See CONSOLE (Page 6-5)
2. Remove anchored cable strap (3).
  3. Remove lock ring (1).
    - a. Gently pry three latches (2) upward to release lock ring.
    - b. Remove lock ring.
  4. Remove IM (4).
    - a. Remove IM form top side of console (5).
  5. Remove rubber gasket.

**INSTALL**

| FASTENER                        | TORQUE VALUE |             |
|---------------------------------|--------------|-------------|
| IM screw: Fork-mounted fairing  | 10-20 in-lbs | 1.1-2.3 N-m |
| IM screw: Frame-mounted fairing | 12-17 in-lbs | 1.4-1.9 N-m |

**Fairing Models**

1. See Figure 8-33 or Figure 8-34. Install IM (2).
  - a. If removed, install bezel (3).
  - b. Install IM.
  - c. Fork-mounted fairing: Install IM screws (1). Tighten. Torque: 10-20 in-lbs (1.1-2.3 N-m) *IM screw: Fork-mounted fairing*
  - d. Frame-mounted fairing: Install IM screws (1). Tighten. Torque: 12-17 in-lbs (1.4-1.9 N-m) *IM screw: Frame-mounted fairing*
2. Connect IM connector (4).

**REMOVE***NOTE*

- Both the ECM and the speedometer retain the odometer value. If the speedometer is replaced, the new speedometer will display the odometer value stored in the ECM. The new speedometer will lock to the mileage stored in the ECM after 31 mi (50 km) have been accumulated. The trip B odometer will display the countdown mileage.
- If the speedometer is installed on another vehicle after it has locked to the ECM, the odometer will display "VIN ERR" on the new vehicle. If the speedometer is removed from the vehicle before the countdown reaches zero, it will reset the mileage countdown to 31 mi (50 km). This mileage countdown allows for a road test to verify that speedometer replacement was the proper repair.

**Fairing Models**

1. See Figure 8-33 or Figure 8-34. Disconnect Instrument Module (IM) connector (4).
2. Remove IM (2).
  - a. Remove IM screws (1).
  - b. Remove IM.
  - c. If necessary, remove bezel (3).

**Non-Fairing Models**

1. See Figure 8-35. Remove IM connector (6).

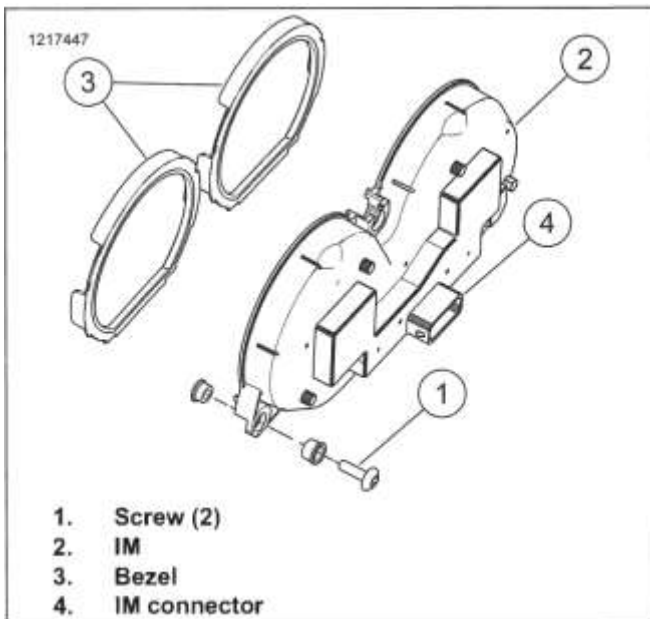


Figure 8-33. Instrument Module: Fork-Mounted Fairing

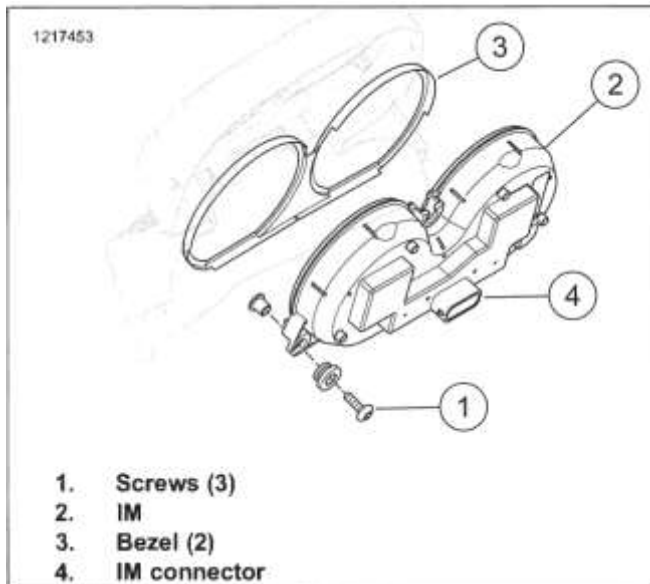


Figure 8-34. Instrument Module: Frame-Mounted Fairing

### Non-Fairing Models

1. See Figure 8-35. Lubricate groove of rubber gasket.
  - a. Using isopropyl alcohol or glass cleaner, lubricate groove of rubber gasket.
2. Install rubber gasket.
  - a. Place the gasket into position around the console IM bore.
3. Install IM.
  - a. Lubricate rubber gasket with isopropyl alcohol or glass cleaner, if necessary.

#### NOTE

*The IM should fit snugly against the rubber gasket without movement.*

4. Install lock ring (1).
  - a. Place lock ring over back of IM aligning two slots with console bosses.
  - b. Press latches (2) down until they lock into position.
5. Connect IM connector (6).
6. Insert anchored cable strap (3).

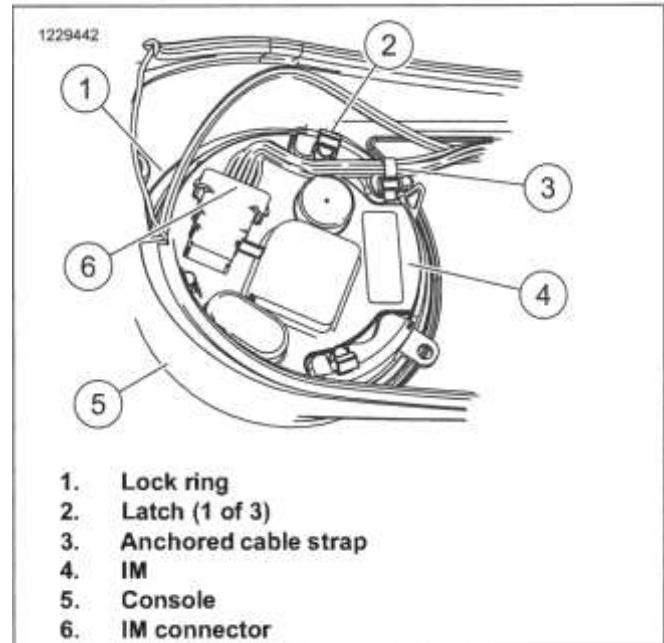


Figure 8-35. Non-Fairing IM

### COMPLETE

1. Non-fairing models:
  - a. Install console. See CONSOLE (Page 6-5)
  - b. Install seat. See SEAT (Page 3-148)
2. Frame-mounted fairing: Install ignition switch knob. See IGNITION SWITCH (Page 8-16)
3. Fork-mounted fairing: See FAIRING: FORK MOUNTED (Page 3-89)
  - a. Install fairing upper support bracket.
  - b. Install fairing vent.
  - c. Install outer fairing.
4. Install main fuse. See POWER DISCONNECT (Page 8-8)
5. Install left side cover. See LEFT SIDE COVER (Page 3-62)
6. Install left saddlebag. See SADDLEBAGS (Page 3-161)

**PREPARE**

1. Remove left saddlebag. See SADDLEBAGS (Page 3-161).
2. Remove left side cover. See LEFT SIDE COVER (Page 3-62).
3. Remove main fuse. See POWER DISCONNECT (Page 8-8).
4. Remove seat. See SEAT (Page 3-148).
5. Remove console. See CONSOLE (Page 6-5).

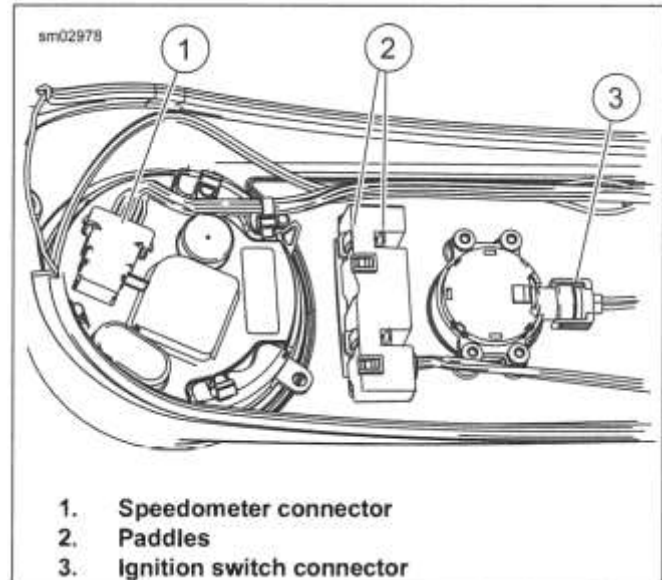
**REMOVE**

1. See Figure 8-36. Disconnect ignition switch connector (3) and speedometer connector (1).
2. Free harness from metal clips.
3. Remove indicator lamp assembly from console:
  - a. Insert large screwdriver blade under rear corner of indicator lamp assembly.
  - b. Squeeze front and rear paddles (2) on same side of assembly while rotating screwdriver.
  - c. When one side of assembly becomes free, repeat procedure on opposite side to remove unit.

**INSTALL**

1. See Figure 8-36. Install indicator lamp assembly into console:
  - a. Place assembly into position in console. Engage four paddles (2) in slots of indicator lamp assembly.
  - b. While pushing down on assembly, push up on lens on outboard side of console until assembly fits snugly.

2. Mate connectors.
  - a. Mate speedometer connector (1).
  - b. Mate ignition switch connector (3).
3. Secure harness under metal clips to capture harness.



**Figure 8-36. Release Paddles to Free Indicator Lamp Assembly: Road King**

**COMPLETE**

1. Install console. See CONSOLE (Page 6-5).
2. Install seat. See SEAT (Page 3-148).
3. Install main fuse. See POWER DISCONNECT (Page 8-8).
4. Install left side cover. See LEFT SIDE COVER (Page 3-62).
5. Install left saddlebag. See SADDLEBAGS (Page 3-161).

## PREPARE

1. Remove left saddlebag. See SADDLEBAGS (Page 3-161)
2. Remove left side cover. See LEFT SIDE COVER (Page 3-62)
3. Remove main fuse. See POWER DISCONNECT (Page 8-8)
4. Fork mounted fairing: See FAIRING: FORK MOUNTED (Page 3-89)
  - a. Remove outer fairing.
  - b. Remove fairing vent.
  - c. Remove fairing upper support bracket.
5. Frame mounted fairing: See FAIRING: FRAME MOUNTED (Page 3-100)
  - a. Remove outer fairing.
  - b. Remove fairing vent.

## REMOVE

1. Disconnect gauge connector.
2. See Figure 8-37. Remove gauge.
  - a. Remove screws (1).
  - b. Remove gauge assembly (3, 4, 5).
  - c. Remove back clamp (3).
  - d. Remove bezel (5).

## INSTALL

1. See Figure 8-37. Assemble gauge (4).

**NOTE**

Fuel and battery icons (2) are cast into the back clamp and

| FASTENER            | TORQUE VALUE |             |
|---------------------|--------------|-------------|
| Fairing gauge screw | 8-15 in-lbs  | 0.9-1.7 N-m |

inner fairing near each gauge opening to identify correct location. The voltmeter is always mounted on the right side and uses the tan back clamp. The fuel gauge is always mounted on the left side and uses the black back clamp.

- a. Install back clamp (3).
  - b. Install bezel (5).
2. Install gauge assembly.
  3. Install screws (1). Tighten.  
Torque: 8-15 in-lbs (0.9-1.7 N-m) *Fairing gauge screw*

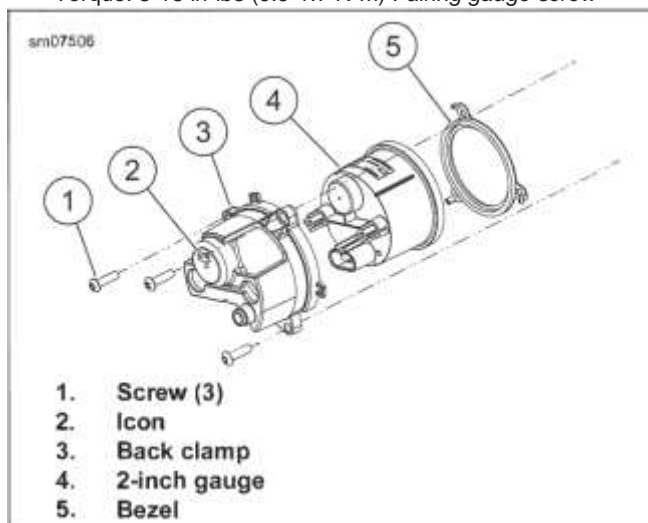


Figure 8-37. Fairing Gauge

## COMPLETE

1. Fork mounted fairing: See FAIRING: FORK MOUNTED (Page 3-89)
  - a. Install fairing upper support bracket.
  - b. Install fairing vent.
  - c. Install outer fairing.
2. Fork mounted fairing: See FAIRING: FRAME MOUNTED (Page 3-100)
  - a. Install fairing vent.
  - b. Install outer fairing.
3. Install main fuse. See POWER DISCONNECT (Page 8-8)
4. Install left side cover. See LEFT SIDE COVER (Page 3-62)
5. Install left saddlebag. See SADDLEBAGS (Page 3-161)

## PREPARE

1. Remove left saddlebag. See SADDLEBAGS (Page 3-161)
2. Remove left side cover. See LEFT SIDE COVER (Page 3-62)
3. Remove main fuse. See POWER DISCONNECT (Page 8-8)

## REMOVE

1. See Figure 8-38. Disconnect fuel level gauge connector (2).
  - a. Draw fuel gauge connector out of tunnel under left side of fuel tank.
  - b. Disconnect fuel level gauge connector.
2. Extract terminals (3) from fuel level gauge connector. See Electrical Diagnostic Manual.
3. Remove convoluted tubing (4).
4. Remove fuel level gauge.

**NOTE**

*Do not twist during removal.*

- a. Pull upward just far enough to free the gauge from the fuel tank.
  - b. Remove fuel gauge from motorcycle while feeding wires and terminals up through tube.
5. **If reusing fuel level gauge:** Inspect rubber gasket (5) for damage.

## INSTALL

1. **New fuel level gauge:** See Figure 8-38.
  - a. Measure original fuel level gauge wiring length (6).
  - b. Cut **new** fuel level gauge wiring length to original length.
  - c. Crimp **new** terminals (3) to fuel level gauge wiring. See Electrical Diagnostic Manual.
2. See Figure 8-38. Install fuel level gauge (1).
  - a. Install rubber gasket (5) over wiring.

**NOTE**

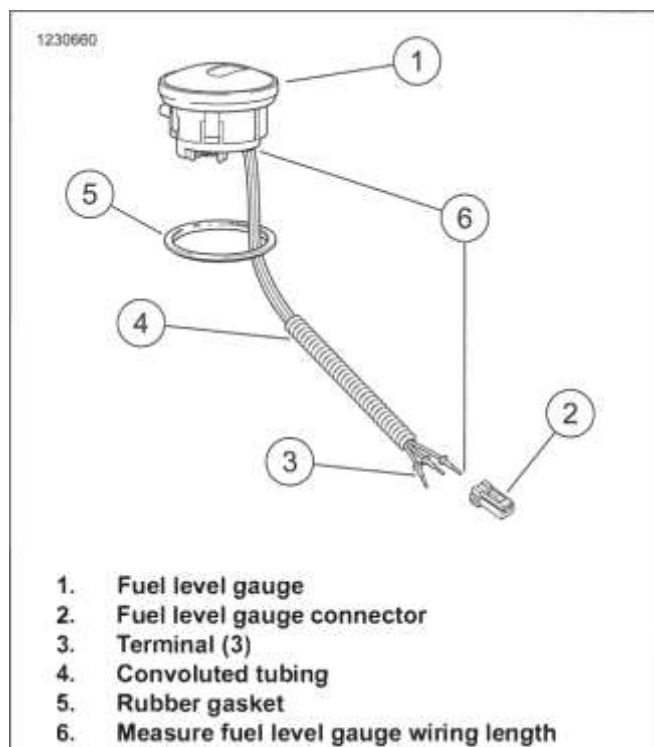
*Install rubber gasket with flat side contacting edge of fuel level gauge.*

- b. Feed wires down into fuel tank tube while lowering gauge into position.
- c. When terminals exit bottom of fuel tank, gently pull wires while lowering the fuel gauge.

**NOTE**

*Do not twist the gauge during installation.*

- d. Hold the gauge firmly and press downward until it snaps in place.
3. Install convoluted tubing (4) on wires.
  4. Install fuel level gauge connector (2). See Electrical Diagnostic Manual.
  5. Connect fuel level gauge connector.
    - a. Route connector forward and then inboard between front of crossover hose fitting and bottom of fuel tank.
    - b. Connect fuel level gauge connector and push into



**Figure 8-38. Fuel Level Gauge - Non-Fairing Models**

## COMPLETE

tunnel of fuel tank.

1. Install main fuse. See POWER DISCONNECT (Page 8-8)
2. Install left side cover. See LEFT SIDE COVER (Page 3-62)
3. Install left saddlebag. See SADDLEBAGS (Page 3-161)

**OIL PRESSURE SWITCH****PREPARE**

1. Remove left side cover. See LEFT SIDE COVER (Page 3-62).
2. Remove main fuse. See POWER DISCONNECT (Page 8-8).

**REMOVE**

1. See Figure 8-39. Disconnect connector (2).
2. Remove switch (1).

**INSTALL**

1. See Figure 8-39. Install switch (1). Tighten.

| FASTENER             | TORQUE VALUE |           |
|----------------------|--------------|-----------|
| Switch, Oil Pressure | 13-17 ft-lbs | 17-23 N-m |

Torque: 13-17 ft-lbs (17-23 N-m) *Switch, Oil Pressure*

2. Connect connector (2).

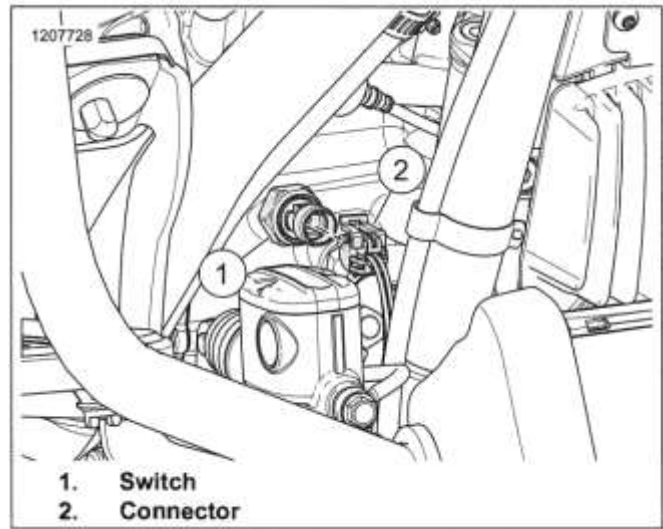


Figure 8-39. Oil Pressure Switch

**COMPLETE**

1. Install main fuse. See POWER DISCONNECT (Page 8-8).
2. Install left side cover. See LEFT SIDE COVER (Page 3-62).

## PREPARE

1. Remove left side cover. See LEFT SIDE COVER (Page 3-62).
2. Remove main fuse. See POWER DISCONNECT (Page 8-8).
3. Place transmission in NEUTRAL.

3. *Wires are interchangeable.*

NOTE

Connect harness wires (1).

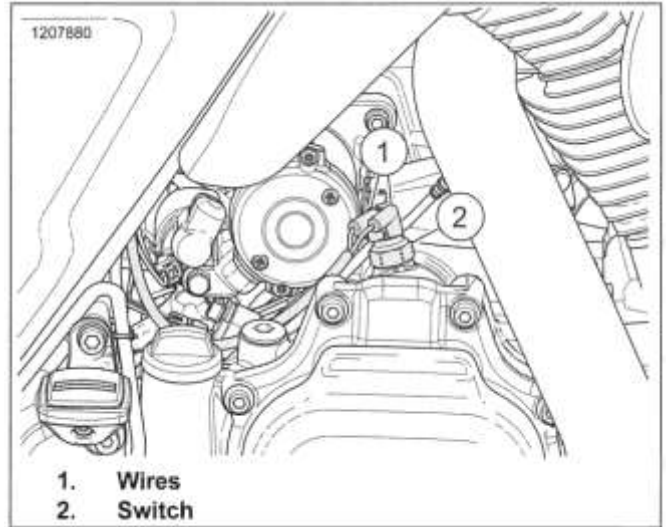


Figure 8-40. Neutral Indicator Switch

## REMOVE

1. See Figure 8-40. Remove connectors (1) from neutral switch posts.
2. Remove neutral switch (2) and O-ring.

## INSTALL

| FASTENER                  | TORQUE VALUE   |               |
|---------------------------|----------------|---------------|
| Switch, Neutral Indicator | 120-180 in-lbs | 13.6-20.3 N-m |

1. Verify transmission is in NEUTRAL.
2. See Figure 8-40. Install **new** switch (2) and O-ring. Tighten.  
Torque: 120-180 **in-lbs** (13.6-20.3 N-m) *Switch, Neutral Indicator*

## COMPLETE

1. Install main fuse. See POWER DISCONNECT (Page 8-8).
2. Install left side cover. See LEFT SIDE COVER (Page 3-62).

## PREPARE \_\_\_\_\_

1. Remove left side cover. See LEFT SIDE COVER (Page 3-62).
2. Remove main fuse. See POWER DISCONNECT (Page 8-8).

## REMOVE \_\_\_\_\_

### Horn Assembly with Bracket

1. See Figure 8-41. Remove screws (9) and washers (10) and rotate assembly for access to inboard side.
2. Remove wiring from J-clamp (12).
3. Disconnect horn connectors.

### Horn Assembly

1. See Figure 8-41. Remove nut (4) and washer (5).
2. Remove wiring from J-clamp (12).
3. Disconnect horn connectors.

## INSTALL

| FASTENER                             | TORQUE VALUE  |               |
|--------------------------------------|---------------|---------------|
| Horn bracket acorn nut               | 80-120 in-lbs | 9-13.6 N-m    |
| Horn bracket to cylinder head screws | 35-40 ft-lbs  | 47.5-54.2 N-m |
| Horn rubber mount                    | 120-180in-lbs | 13.6-20.3 N-m |

| PART NUMBER | CONSUMABLE   |
|-------------|--|
| Loctite 271 | LOCTITE 271 HIGH STRENGTH THREADLOCKER AND SEALANT (RED) |

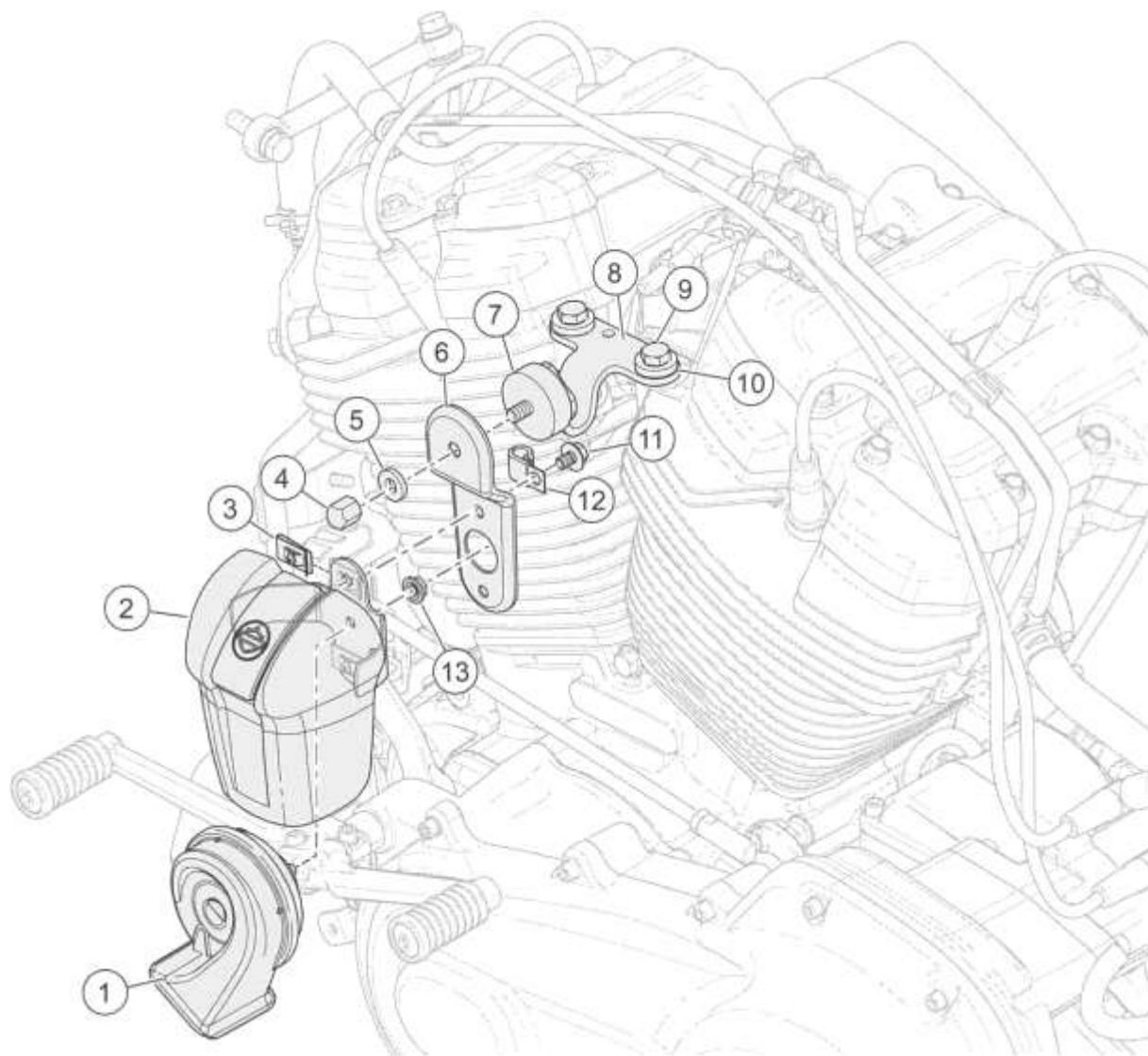
### Horn Assembly with Bracket

1. See Figure 8-41. Install horn.
  - a. Attach horn connectors.
  - b. Install wiring in J-clamp (12).
  - c. Install bracket (8) to cylinder heads with two screws (9) and washers (10). Tighten.  
  
Torque: 35-40 ft-lbs (47.5-54.2 N-m) *Horn bracket to cylinder head screws*

### Horn Assembly

1. If removed, install mount (7).
  - a. Apply threadlocker to mount stud.  
LOCTITE 271 HIGH STRENGTH THREADLOCKER AND SEALANT (RED) (Loctite 271)
  - b. Install in bracket (8). Tighten.  
  
Torque: 120-180 in-lbs (13.6-20.3 N-m) *Horn rubber mount*
2. Install horn.
  - a. Attach terminals.
  - b. Install wiring in J-clamp (12).
  - c. Install horn bracket (6) onto rubber mount with flat washer (5) and acorn nut (4). Tighten.  
  
Torque: 80-120 in-lbs (9-13.6 N-m) *Horn bracket acorn nut*





- |                 |                     |
|-----------------|---------------------|
| 1. Horn         | 8. Mounting bracket |
| 2. Cover        | 9. Screw (2)        |
| 3. Speednut (2) | 10. Washer (2)      |
| 4. Acorn nut    | 11. Screw (2)       |
| 5. Washer       | 12. J-clamp         |
| 6. Bracket      | 13. Flange nut      |
| 7. Rubber mount |                     |

Figure 8-41. Horn

**DISASSEMBLE**

- See Figure 8-41. Remove nut (13).
- Remove horn (1) from cover (2).
- Remove screws (11) and J-clamp (12).

**ASSEMBLE**

- See Figure 8-41. If removed, install speednuts (3) on cover (2).

| FASTENER              | TORQUE VALUE  |             |
|-----------------------|---------------|-------------|
| Horn cover to bracket | 35-40 in-lbs  | 3.9-4.5 N-m |
| Horn stud flange nut  | 80-100 in-lbs | 9-11.3 N-m  |

- Mount cover to bracket.
  - Install upper screw (11) with J-clamp (12) and bracket (6).
  - Install lower screw (11).
  - Tighten screws.  
Torque: 35-40 in-lbs (3.9-4.5 N-m) *Horn cover to bracket*

- NOTE**

*Over-tightening flange nut can cause permanent horn damage.*

Mount horn to cover.

- Insert horn stud through hole in cover (2) and bracket (6).

b. Install flange nut (13). Tighten.

Torque: 80--100 **in-lbs** (9-11.3 N-m) *Horn stud flange nut*

**COMPLETE** \_\_\_\_\_

1. Install main fuse. See POWER DISCONNECT (Page **8-8**).

2. Install left side cover. See LEFT SIDE COVER (Page 3-62).

## BULB REPLACEMENT

### Bulb Replacement: LED Type

LED headlamp contains no service parts including bulbs. Replace the entire assembly if failure occurs.

### Bulb Replacement: Halogen Type

#### A WARNING

Handle bulb carefully and wear eye protection. Bulb contains gas under pressure, which, if not handled carefully, could cause serious eye injury. (00062b)

#### NOTICE

When replacement is required, use only the specified sealed beam unit or bulb, available from a Harley-Davidson dealer. An improper wattage sealed beam or bulb, can cause charging system problems. (00209a)

#### NOTE

*This headlamp assembly uses separate quartz halogen bulbs for the low beam and the high beam. HD/ models also contain a position lamp bulb.*

1. Remove headlamp assembly.
2. Disconnect wire harness connectors from the bulbs.
3. Rotate bulb assembly 1/4 turn counterclockwise to remove from the reflector/lens.

#### NOTICE

Never touch the quartz bulb. Fingerprints will etch the glass and decrease bulb life. Handle the bulb with paper or a clean, dry cloth. Failure to do so could result in bulb damage. (00210b)

4. Insert new bulb into reflector/lens and rotate 1/4 turn clockwise.
5. HDI models: Rotate position lamp bulb retainer 1/4 turn counterclockwise to remove. Replace bulb and install bulb retainer in lamp housing.
6. Connect the wiring harness connectors to the bulbs.
7. Secure the headlamp assembly and headlamp door.

## PREPARE

1. Remove left saddlebag. See SADDLEBAGS (Page 3-161).
2. Remove left side cover. See LEFT SIDE COVER (Page 3-62).
3. Remove main fuse. See POWER DISCONNECT (Page 8-8).

## REMOVE AND INSTALL: SINGLE HEADLAMP

| FASTENER  | TORQUE VALUE |             |
|---|--------------|-------------|
| Headlamp door screw                             | 9-18 in-lbs  | 1-2 N-m     |
| Headlamp retaining ring screws: Single headlamp | 23-26 in-lbs | 2.6-2.9 N-m |

### Removal

1. Remove screw at bottom of headlamp door (chrome ring).
2. Rotate door counterclockwise a few degrees. Pull headlamp door straight forward to remove.
3. See Figure 8-42. Remove screws (1) securing retaining ring.
4. Remove headlamp. Disconnect headlamp connectors.

### Installation

1. Attach headlamp connectors.
2. See Figure 8-42. Secure headlamp assembly with retaining ring and screws (1). Tighten.  
Torque: 23-26 in-lbs (2.6-2.9 N-m) *Headlamp retaining ring screws: Single headlamp*
3. Install headlamp door (chrome ring):
  - a. Verify rubber seal is in place on headlamp door. Apply glass cleaner to seal to ease installation.
  - b. With headlamp door rotated a few degrees counterclockwise, push headlamp door straight onto headlamp.
  - c. Rotate clockwise until screw can be installed.
  - d. Install screw. Tighten.  
Torque: 9-18 in-lbs (1-2 N-m) *Headlamp door screw*

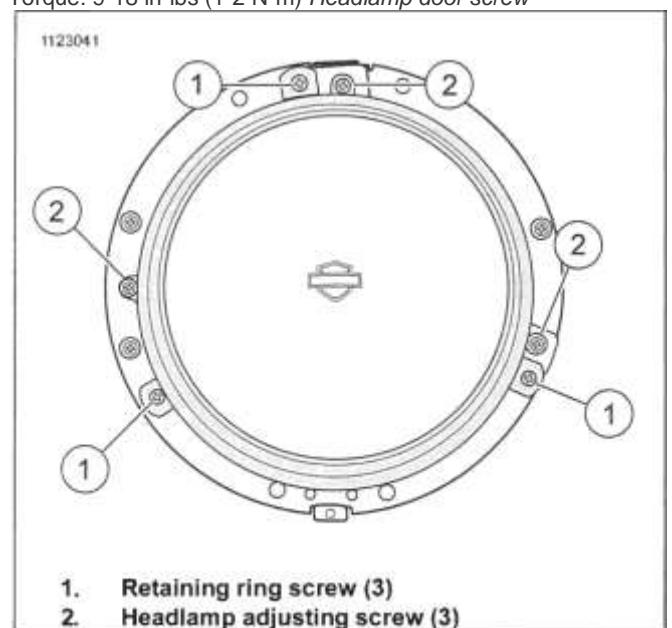


Figure 8-42. Headlamp Retaining Ring

# REMOVE AND INSTALL: DUAL HEADLAMP ALIGN

| FASTENER                       | TORQUE VALUE |             |
|--------------------------------|--------------|-------------|
| Headlamp bezel: Dual headlamp  | 8-15 in-lbs  | 0.9-1.7 N-m |
| Headlamp screws: Dual headlamp | 48-60 in-lbs | 5.4-6.8 N-m |

## Removal

3.

### NOTE

This headlamp assembly contains no service parts including bulbs and rubber boots. Replace assembly upon failure.

1. Remove outer fairing. See FAIRING: FRAME MOUNTED (Page 3-100).
2. See Figure 8-43. Remove four screws (2).
3. Remove headlamp assembly. Disconnect headlamp connector.
4. If necessary, remove screws (3) to remove bezel (4) from each side of headlamp assembly.

## Installation

1. See Figure 8-43. If removed, secure bezel (4) with screws (3) to each side of headlamp assembly. Tighten.  
Torque: 8-15 in-lbs (0.9-1.7 N-m) *Headlamp bezel: Dual headlamp*
2. Attach headlamp connector.

### NOTE

Verify that pins engage hole in vent housings (arrows) during headlamp installation.

3. Secure headlamp assembly with four screws (2). Tighten.  
Torque: 48-60 in-lbs (5.4-6.8 N-m) *Headlamp screws: Dual headlamp*
4. Install outer fairing. See FAIRING: FRAME MOUNTED (Page 3-100).

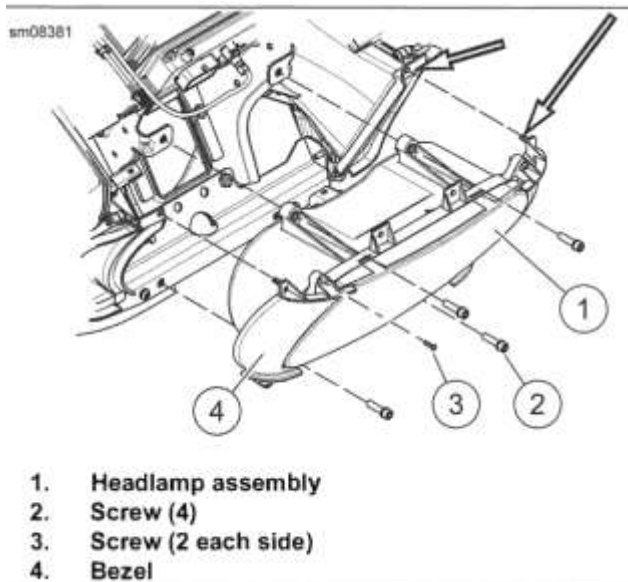


Figure 8-43. Headlamp: FLTR

1. Check tire pressure. See INSPECT TIRES AND WHEELS (Page 2-15).
2. Adjust rear shocks for rider and intended load. See ADJUST SUSPENSION (Page 2-43).

Fill fuel tank or add an equal amount of ballast.

### NOTE

Choose a wall in minimum light.

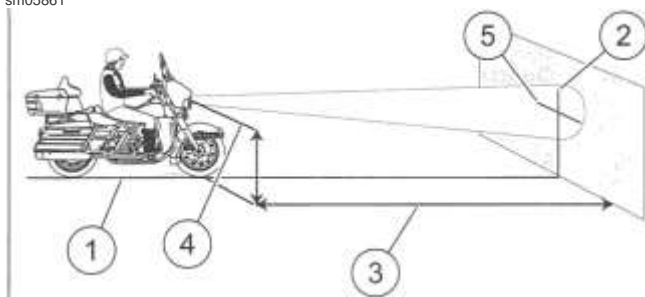
- See Figure 8-44. Park motorcycle on a line (1) perpendicular to the wall.
5. Position motorcycle with front axle specified distance (3) from wall.
6. Draw a vertical centerline (2) on the wall aligned with line (1).

### NOTE

The upper lens is low beam on LED headlamps.

With motorcycle loaded, point front wheel straight forward at wall. Measure distance (4) from the floor to bulb centerline:

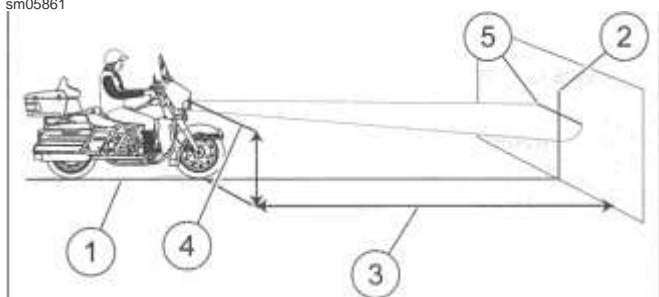
- Quartz halogen: Center of high beam bulb.
  - LED, fork-mounted fairing: Center of low beam bulb.
  - LED, frame-mounted fairing: Center of headlamp face.
8. Draw a horizontal line (5) through the vertical line:
    - Quartz halogen: See Figure 8-44. 2 in (53.3 mm) lower than measured distance.
    - LED, fork-mounted fairing: See Figure 8-45. At measured distance.
    - LED, frame-mounted fairing: See Figure 8-44. 2 in (53.3 mm) lower than measured distance.
  9. The headlamp is aligned when the light beam hot spot is located as shown.
    - Quartz halogen: See Figure 8-48. Hot spot centered on mark with headlamp set to high beam.
    - LED, fork-mounted fairing: See Figure 8-49. Top of hot spot at mark with headlamp set to low beam.
    - LED, frame-mounted fairing: See Figure 8-50. Center of hot spot at mark with headlamp set to high beam.



c. **LED, frame-mounted fairing:** Set headlamp to **high beam**.

1. **Perpendicular line**
2. **Vertical line**
3. **25 ft (7.6 m)**
4. **High beam bulb centerline**
5. **Horizontal line 2.1 in (53.3 mm) lower than high beam centerline**

**Figure 8-44. Headlamp Alignment: Quartz Halogen Type**



1. **Perpendicular line**
2. **Vertical line**
3. **25 ft (7.6 m)**
4. **Low beam bulb centerline**
5. **Horizontal line**

**Figure 8-45. Headlamp Alignment: LED Type (typical)**

**ADJUST** \_\_\_\_\_

| PART NUMBER | TOOL NAME        |
|-------------|------------------|
| FRX181      | FLARE NUT SOCKET |

| FASTENER   | TORQUE VALUE         |               |
|--|----------------------|---------------|
| Auxiliary/fog lamp flange nut: Models with bullet style turn signal lamps            | 20-24 ft-lbs         | 27.1-32.5 N-m |
| Auxiliary/fog lamp flange nut: Models with flat lens turn signal lamps               | 15-18 ft-lbs         | 20.3-24.4 N-m |
| Turn signal lamp to auxiliary/fog lamp bracket screw: Bullet style turn signal lamps | 96-120 <b>in-lbs</b> | 10.9-13.5 N-m |
| Turn signal lamp to auxiliary/fog lamp bracket screws: Flat lens turn signal lamps   | 36-60 <b>in-lbs</b>  | 4.1-6.8 N-m   |

**HEADLAMP**

1. **NOTE**  
Do not remove trim ring for headlamp adjustment.

Set headlamp beam.

- a. **Quartz halogen:** Set headlamp to **high beam**.
- b. **LED, fork-mounted fairing:** Set headlamp to **low beam**.

2. **All except frame-mounted fairing:** See Figure 8-46. Insert a 5/32 in ball end hex wrench through adjuster slots in trim ring.

a. **Horizontal:** Turn horizontal adjusting screw (1) to adjust light beam left or right.

b. **Vertical:** Turn vertical adjusting screw (2) to adjust light beam up or down.

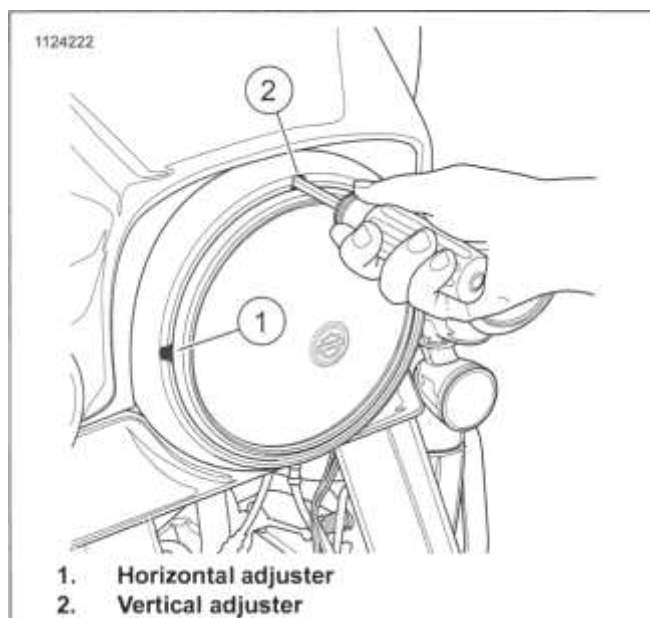
c. See Figure 8-48 or Figure 8-49. Adjust headlamp light beam.

3. **NOTE**

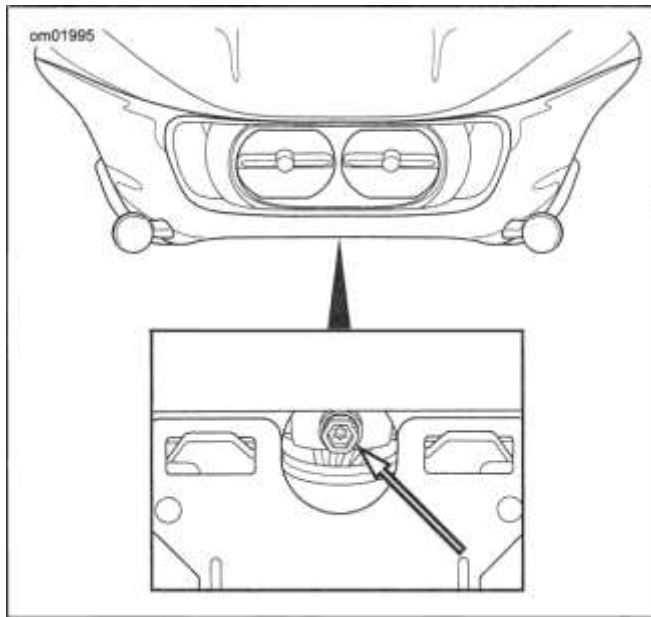
- *Frame-mounted fairing models allow only vertical adjustment.*
- *Any of three tools can be used: 9 mm socket, 6 mm hex or T15 Torx.*

**Frame-mounted fairing models:** See Figure 8-47.

- a. Turn adjuster to adjust light beam up or down.
- b. See Figure 8-50. Adjust headlamp light beam.



**Figure 8-46. Headlamp Adjusters: All except Frame-Mounted Fairing (typical)**



**Figure 8-47. Headlamp Adjuster: Frame-Mounted Fairing AUXILIARY/FOG LAMPS**

1. Place motorcycle facing a target wall as described in Align (Page 8-42).

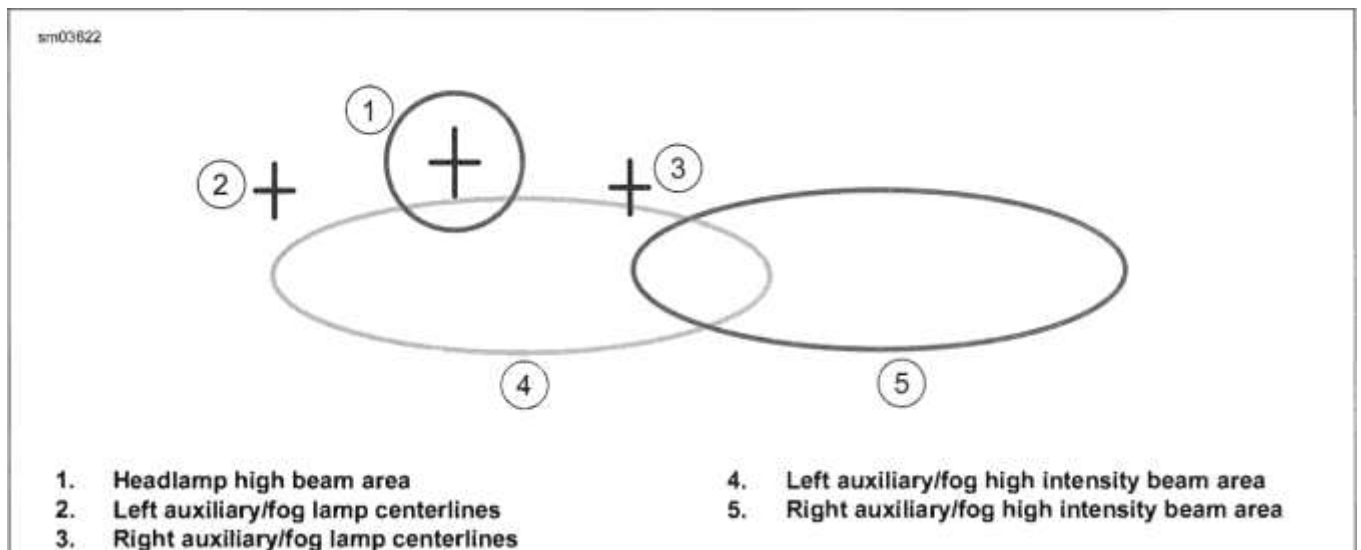
**NOTE**

*Have a person weighing roughly the same as the principal rider sit on the motorcycle.*

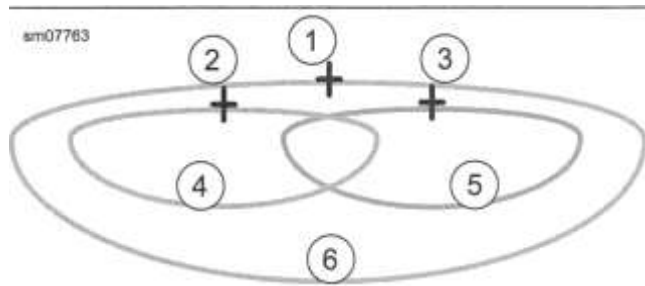
2. With motorcycle upright and rider seated, measure distance from floor to centerline of each auxiliary/fog lamp.
3. Measure horizontal distance from headlamp vertical centerline to vertical centerline of each auxiliary/fog lamp.
4. See Figure 8-48 or Figure 8-49. Mark auxiliary/fog lamp horizontal and vertical centerlines (2, 3) on the wall.
5. Remove turn signal lamp from mounting bracket.
6. Using flare nut socket, loosen auxiliary/fog lamp flange nut only enough to allow lamp adjustment.

Special Tool: FLARE NUT SOCKET (FRX181)

7. Turn on headlamp low beam and cover both headlamp and right auxiliary/fog lamp.
  - a. **Quartz halogen:** Adjust left auxiliary/fog lamp so entire high intensity zone (4) is below and to the right of left auxiliary/fog lamp centerlines as shown in Figure 8-48.
  - b. **LED:** Adjust left auxiliary/fog lamp so entire high intensity zone (4) is below centerline as shown in Figure 8-49.
8. Repeat procedure with right lamp.
9. Tighten auxiliary/fog lamp nut:
  - a. **Models with flat lens turn signal lamps:**  
Torque: 15-18 ft-lbs (20.3-24.4 N-m) *Auxiliary/fog lamp flange nut: Models with flat lens turn signal lamps*
  - b. **Models with bullet style turn signal lamps:**  
Torque: 20-24 ft-lbs (27.1-32.5 N-m) *Auxiliary/fog lamp flange nut: Models with bullet style turn signal lamps*
10. Install turn signal:
  - a. **Models with flat lens turn signal lamps:** Start two screws to secure turn signal lamp to mounting bracket. Verify conduit fits in slot at back of bracket and is not pinched. Tighten.  
Torque: 36-60 **in-lbs** (4.1-6.8 N-m) *Turn signal lamp to auxiliary/fog lamp bracket screws: Flat lens turn signal lamps*
  - b. **Models with bullet style turn signal lamps:** Secure turn signal lamp to mounting bracket. Tighten.  
Torque: 96-120 **in-lbs** (10.9-13.5 N-m) *Turn signal lamp to auxiliary/fog lamp bracket screw: Bullet style turn signal lamps*

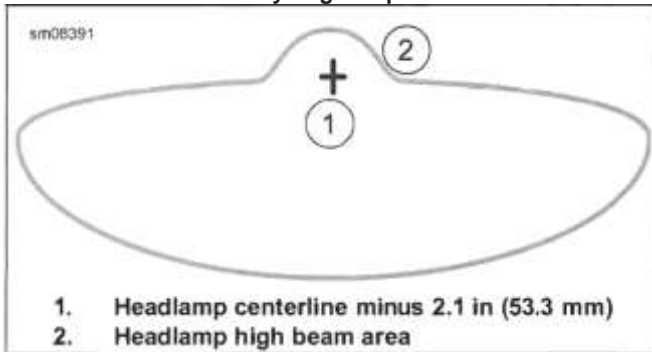


**Figure 8-48. Properly Aim Lamps: Quartz Halogen Type**



1. Headlamp centerline
2. Left auxiliary/fog lamp centerline
3. Right auxiliary/fog lamp centerline
4. Left auxiliary/fog lamp beam area
5. Right auxiliary/fog lamp beam area
6. Headlamp low beam area

**Figure 8-49. Headlamp Pattern: LED Type with Auxiliary/Fog Lamps**



1. Headlamp centerline minus 2.1 in (53.3 mm)
2. Headlamp high beam area

**Figure 8-50. Headlamp Pattern: Frame-Mounted Fairing Models**

**COMPLETE**

1. Install main fuse. See POWER DISCONNECT (Page 8-8).
2. Install left side cover. See LEFT SIDE COVER (Page 3-62).
3. Install left saddlebag. See SADDLEBAGS (Page 3-161).

## AUXILIARY LAMPS

### BULB REPLACEMENT

| FASTENER                      | TORQUE VALUE                      |
|-------------------------------|-----------------------------------|
| Auxiliary/fog lamp door screw | 10-14 <b>in-lbs</b> 1 1.1-1.6 N-m |

#### **A WARNING**

Handle bulb carefully and wear eye protection. Bulb contains gas under pressure, which, if not handled carefully, could cause serious eye injury. (00062b)

#### NOTICE

Never touch the quartz bulb. Fingerprints will etch the glass and decrease bulb life. Handle the bulb with paper or a clean, dry cloth. Failure to do so could result in bulb damage. (00210b)

#### NOTE

Some models have LED auxiliary lamps. LED lamps contain no service parts including bulbs. Replace the lamp assembly if it fails.

### Remove

- See Figure 8-51. Loosen screw (1) and nut (2). Pull bezel (3) from lip of lamp housing (8).
- Disconnect auxiliary/fog lamp connector (5). Remove lamp (4).
- Remove alignment ring (7).
- Quartz halogen models:** Rotate bulb housing 1/4 turn counterclockwise to remove from lamp.

### Install

- Quartz halogen models:** Install **new** bulb/housing assembly. Rotate 1/4 turn clockwise.
- See Figure 8-51. Place alignment ring (7) on back of lamp (4) with index tab (6) facing away from lamp.
- Mate connector (5).
- Engage alignment ring (7) index tab (6) in slot at bottom of lamp housing.
- Hold alignment ring in place and rotate lamp so that index tabs engage slots in alignment ring.
- Install bezel (3) on lamp housing with screw (1) and nut (2) centered at bottom. Tighten.

Torque: 10-14 **in-lbs** (1.1-1.6 N-m) *Auxiliary/fog lamp door screw*

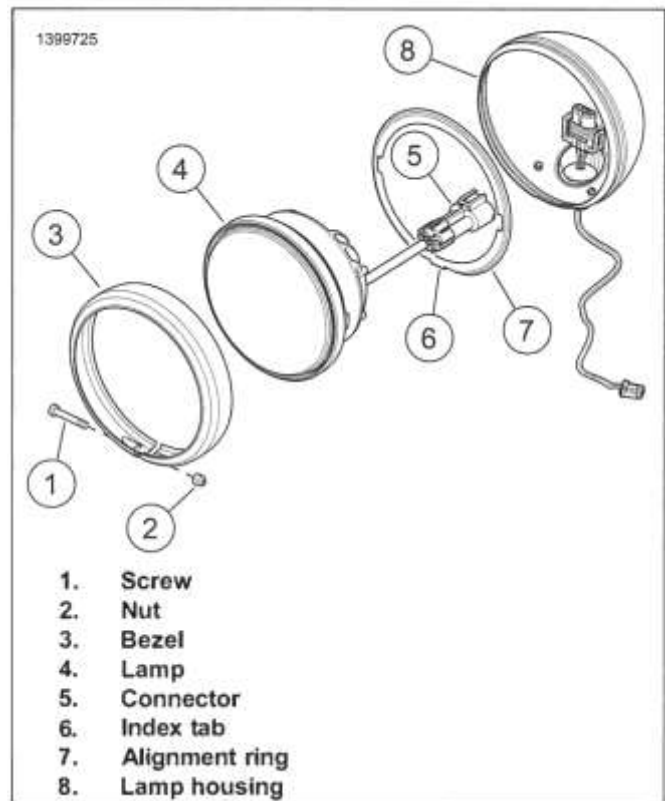


Figure 8-51. Auxiliary Lamp (LED shown)

### PREPARE

- Remove left side cover. See LEFT SIDE COVER (Page 3-62).
- Remove main fuse. See POWER DISCONNECT (Page 8-8).
- Remove bulb. See Bulb Replacement in this section.

### REMOVE

#### Lamp Housing with Bracket

| PART NUMBER | TOOL NAME        |
|-------------|------------------|
| FRX181      | FLARE NUT SOCKET |

#### NOTE

On models not equipped with auxiliary/fog lamps, removal of lamp bracket is similar.

- Road King Models:**
  - See Figure 8-52. Disconnect both lamp connectors (3, 4) located on left steering head.
  - Cut cable straps securing harnesses to lower fork bracket.
  - Pull harnesses down through openings in lower fork bracket.
  - Loosen acorn nuts securing lamp bracket.



## 2. Fairing Models:

- a. Remove acorn nuts securing lamp brackets.
- b. Pull lamp bracket away from fork and separate

3. Remove auxiliary/fog lamp bracket.  
electrical connector.

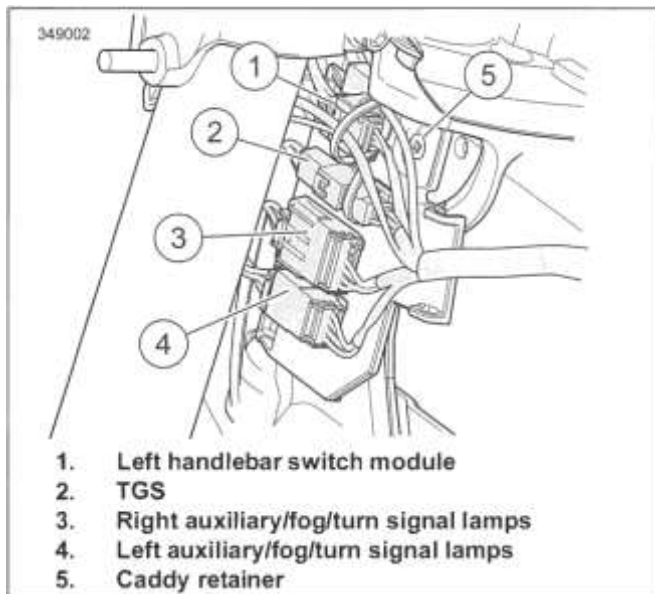


Figure 8-52. Left Side Connectors: Road King Models

## Lamp Housing

1. Disassemble auxiliary/fog lamp. See Bulb Replacement (Page 8-46).
2. Remove appropriate terminals from connector housing. Refer to Table 8-5 or Table 8-6. See the electrical diagnostic manual.
3. See Figure 8-53. Remove screw (1) and washer to release turn signal lamp (11) from bracket.
4. Use flare nut socket to remove locknut (10), lockwasher (9) and clamp block (8).  
Special Tool: FLARE NUT SOCKET (FRX181)
5. Remove auxiliary/fog lamp housing (2) from bracket.
6. Remove rubber washer (7).

Table 8-5. FLHTC/U, FLHTK Auxiliary/Fog Lamps [31L/R]

| LEFT SIDE [31L] |         | RIGHT SIDE [31R] |         |
|-----------------|---------|------------------|---------|
| WIRE COLOR      | CHAMBER | WIRE COLOR       | CHAMBER |
| GY/BK           | 4       | GY/BK            | 4       |

Note: Terminals 1,2 and 3 are reserved for the turn signal lamp.

Table 8-6. FLHR/C Auxiliary/Fog Lamps [73]

| LEFT SIDE  |         | RIGHT SIDE |         |
|------------|---------|------------|---------|
| WIRE COLOR | CHAMBER | WIRE COLOR | CHAMBER |
| GY/BK      | 1       | GY/BK      | 2       |

## INSTALL

| PART NUMBER | TOOL NAME        |
|-------------|------------------|
| FRX181      | FLARE NUT SOCKET |

| FASTENER  | TORQUE VALUE   |               |
|---|----------------|---------------|
| Auxiliary/fog lamp stud locknut                       | 20-24 ft-lbs   | 27.1-32.5 N-m |
| Front turn signal mounting screw: bullet style        | 96-120 in-lbs  | 10.9-13.6 N-m |
| Turn/aux/fog lamp bracket acorn nut, fairing models   | 120-180 in-lbs | 13.6-20.3 N-m |
| Turn/aux/fog lamp bracket acorn nut, road king models | 72-108 in-lbs  | 8.1-12.2 N-m  |

## Lamp Housing

1. Lay old auxiliary/fog lamp next to new auxiliary/fog lamp and cut wire to length.
2. Strip specified length of insulation off wire and crimp on new socket terminal. See the electrical diagnostic manual.  
 $\frac{3}{8}$  in (4.8 mm)
3. See Figure 8-53. Install rubber washer (7) on stud.
4. Position auxiliary/fog lamp housing on bracket. Install clamp block (8), lockwasher (9) and locknut (10).
5. Use flare nut socket to tighten locknut (10).  
Torque: 20-24 ft-lbs (27.1-32.5 N-m) *Auxiliary/fog lamp stud locknut*  
Special Tool: FLARE NUT SOCKET (FRX181)
6. Route wire through passage in bracket and protective conduit.
7. Install terminals into connector housing. See the electrical diagnostic manual. Refer to Table 8-5 or Table 8-6. for terminal location.
8. Install turn signal lamp. Secure with screw (1). Tighten.  
Torque: 96-120 in-lbs (10.9-13.6 N-m) *Front turn signal mounting screw: bullet style*

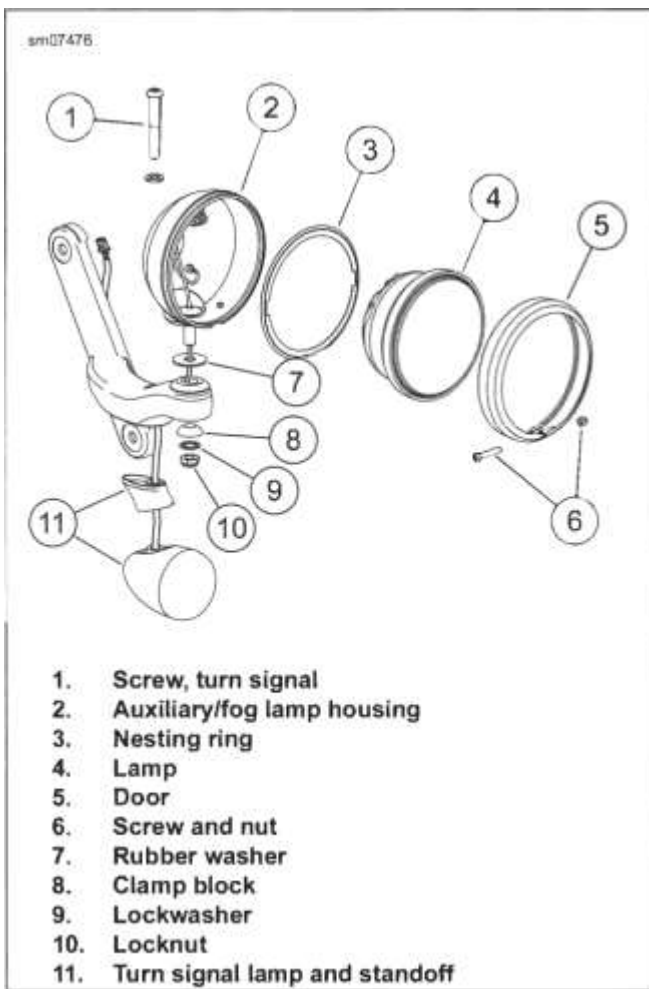


Figure 8-53. Auxiliary/Fog Lamp Assembly

### Lamp Housing with Bracket

1. Fairing Models:
  - a. Mate electrical connectors.
  - b. Attach lamp bracket with acorn nuts. Tighten.  
Torque: 120-180 in-lbs (13.6-20.3 N-m)  
*Turn/aux/fog lamp bracket acorn nut, fairing models*
2. Road King Models:
  - a. Install auxiliary/fog lamp bracket with bushings outside bracket.

- b. Install acorn nuts. Tighten.  
Torque: 72-108 in-lbs (8.1-12.2 N-m) *Turn/aux/fog lamp bracket acorn nut, road king models*
- c. See Figure 8-54. Pull harnesses up through openings in lower fork bracket.
- d. Connect both lamp connectors (3, 4).
- e. Install cable straps securing harnesses to lower fork bracket.

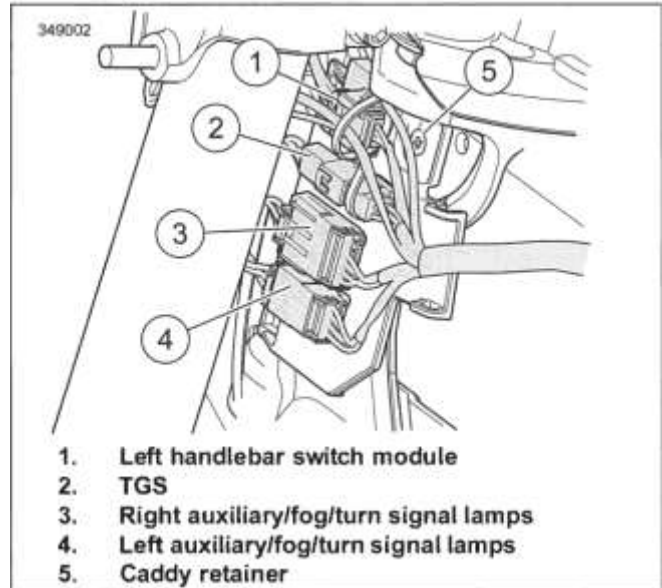


Figure 8-54. Left Side Connectors: Road King Models

### ADJUST

See HEADLAMP (Page 8-41).

### COMPLETE

1. Install main fuse. See POWER DISCONNECT (Page 8-8).
2. Install left side cover. See LEFT SIDE COVER (Page 3-62).

**BULB REPLACEMENT**

| PART NUMBER | CONSUMABLE                   |
|-------------|------------------------------|
| 11300004    | ELECTRICAL CONTACT LUBRICANT |

**Bullet Style***NOTE*

Models with LED lamps do not contain replacement bulbs.

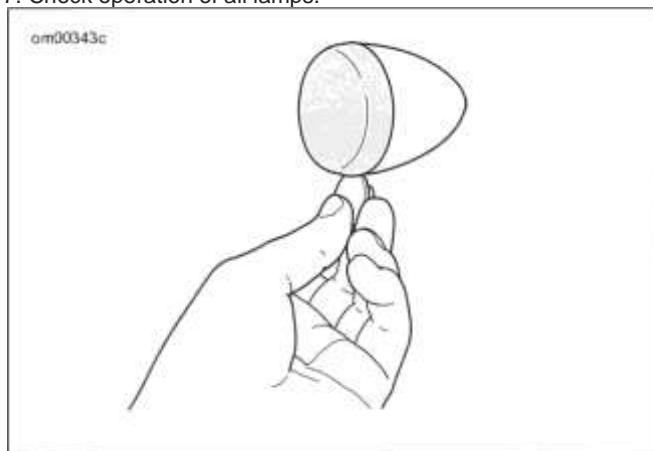
Replace the LED assembly

- See Figure 8-55. Insert a coin or the blade of a small screwdriver into the notch at the bottom of the lens cap. Carefully twist until the lens cap pops out of the lamp housing.
- Push bulb in and rotate counterclockwise. Pull bulb from socket.
- Inspect condition of electrical contacts in socket. If necessary, clean with a small wire brush and electrical contact cleaner.
- Apply electrical contact lubricant to contacts in socket and at bottom of **new** bulb.  
Consumable: ELECTRICAL CONTACT LUBRICANT (11300004)
- Align pins on bulb with pin guides in bulb socket. Push bulb in and turn clockwise to lock in place.
- Snap lens cap onto the lamp housing with notch at bottom.

**A WARNING**

**Be sure that all lights and switches operate properly before operating motorcycle. Low visibility of rider can result in death or serious injury. (00316a)**

7. Check operation of all lamps.



**Figure 8-55. Remove Lens**

**Flat Lens Style**

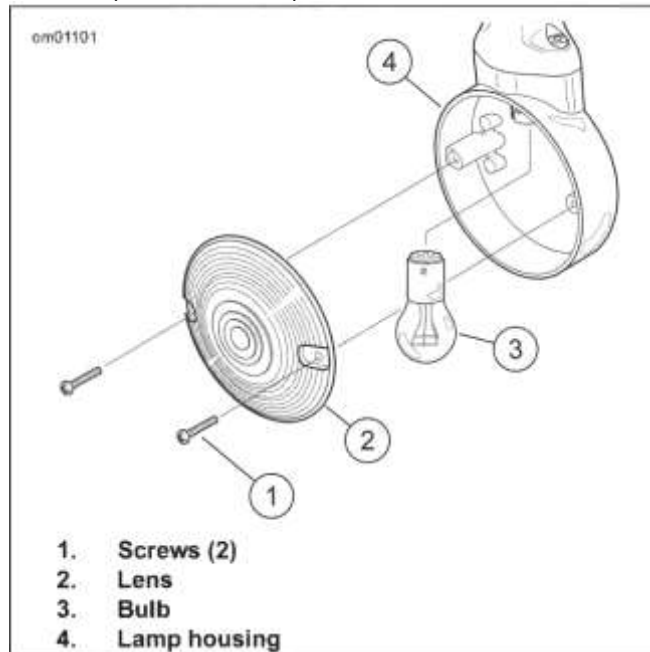
- See Figure 8-56. Remove two screws (1) to release lens (2) from lamp housing (4).

- While pushing bulb (3) in, rotate counterclockwise to remove.
- Inspect condition of electrical contacts in socket. If necessary, clean with a small wire brush and electrical contact cleaner.
- Apply electrical contact lubricant to contacts in socket and at bottom of **new** bulb.  
Consumable: ELECTRICAL CONTACT LUBRICANT (11300004)
- Align pins on bulb with pin guides in bulb socket. Push bulb in and turn clockwise to lock in place.
- Secure lens (2) to lamp housing (4) with two screws (1).

**A WARNING**

**Be sure that all lights and switches operate properly before operating motorcycle. Low visibility of rider can result in death or serious injury. (00316a)**

- Check operation of all lamps.



**Figure 8-56. Turn Signal Lamp Assembly: Flat Lens Style**

**PREPARE**

- Remove left side cover. See LEFT SIDE COVER (Page 3-62).
- Remove main fuse. See POWER DISCONNECT (Page 8-8).

## REMOVE AND INSTALL: HANDLEBAR MOUNT

### Remove

1. Remove turn signal lamp and mirror. See MIRRORS (Page 3-132).
2. Separate hand control housings. Disconnect turn signal lamp connector. See LEFT HAND CONTROL MODULE (LHCM) (Page 8-22) and RIGHT HAND CONTROL MODULE (RHCM) (Page 8-25).

### Install

1. Connect turn signal lamp connector. Assemble hand control housings. See RIGHT HAND CONTROL MODULE (RHCM) (Page 8-25) and LEFT HAND CONTROL MODULE (LHCM) (Page 8-22).
2. Install turn signal lamp and mirror. See MIRRORS (Page 3-132).

## REMOVE AND INSTALL: LIGHT BAR MOUNT

| FASTENER  | TORQUE VALUE        |             |
|---|---------------------|-------------|
| Turn signal lamp, front, mounting bracket screws: Flat lens style | 36-60 <b>in-lbs</b> | 4.1-6.8 N-m |

### Remove

1. See Figure 8-57. Disconnect front signal lamps connectors (3, 4).
2. Remove terminals from connector housing. See the electrical diagnostic manual.
3. Remove two screws to release turn signal lamp from mounting bracket.

#### 4. NOTE

*Make sure that chaser wire is of sufficient strength to pull terminals through conduit without breaking. Wire lengths must also be long enough that free ends are not lost in conduit when pulled.*

See Figure 8-58. Obtain three equal lengths of strong flexible wire for use as chaser wires. Securely attach a chaser wire to terminal of each wire.

5. Carefully pull wires to draw terminals through both sections of conduit. For best results, pull one wire at a time.
6. Remove chaser wire from terminals.

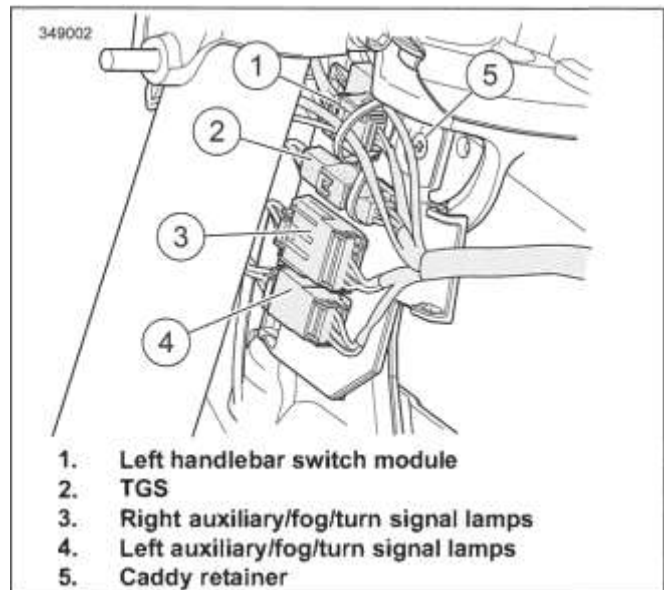


Figure 8-57. Left Side Connectors: Road King Models

### Install

1. Lay old turn signal lamp next to **new** turn signal lamp and cut wires to length.
2. Strip specified length of insulation off wires and crimp on **new** terminals. See the electrical diagnostic manual.  
  
% in (4.8 mm)
3. Secure chaser wires to terminals.
4. Carefully draw terminals back through conduit.
5. Remove chaser wires.
6. Install terminals into connector housing. See the electrical diagnostic manual.
7. Start two screws to secure turn signal lamp to mounting bracket. Verify that conduit is not pinched. Tighten.  
  
Torque: 36-60 **in-lbs** (4.1-6.8 N-m) *Turn signal lamp, front, mounting bracket screws: Flat lens style*
8. See Figure 8-57. Connect front signal lamps connectors (3, 4).

### A WARNING

**Be sure that all lights and switches operate properly before operating motorcycle. Low visibility of rider can result in death or serious injury. (00316a)**

9. Check operation of all lamps.

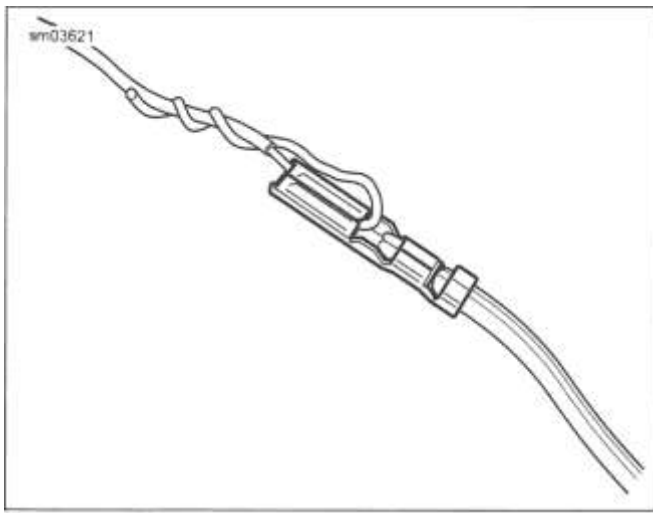


Figure 8-58. Fix Chaser Wire to Socket Terminal

## **COMPLETE**

1. Install main fuse. See POWER (Page 8-8). DISCONNECT
2. Install left side cover. See LEFT (Page 3-62). SIDE COVER

## PREPARE

1. Remove left side cover. See LEFT SIDE COVER (Page 3-62).
2. Remove main fuse. See POWER DISCONNECT (Page 8-8).
3. Remove outer fairing. See FAIRING: FORK MOUNTED (Page 3-89).
4. Remove front fender. See FRONT FENDER (Page 3-134).

## REMOVE

1. Remove wires from connector housing. See the electrical diagnostic manual.
2. See Figure 8-59. Remove nuts (2) securing left fender trim strip. Remove trim strip.
3. Remove nuts (3) securing fender tip lamp. Remove lamp and harness assembly.

## INSTALL

| FASTENER                  | TORQUE VALUE        |             |
|---------------------------|---------------------|-------------|
| Fender tip lamp, front    | 20-25 <b>in-lbs</b> | 2.3-2.8 N-m |
| Fender trim strips, front | 10-15 <b>in-lbs</b> | 1.1-1.7 N-m |

1. **NOTE**

Over-tightening screws can crack the bracket or scratch fender paint.

See Figure 8-59. Mount fender tip lamp.

- a. Secure with nuts (3). Tighten.  
Torque: 20-25 **in-lbs** (2.3-2.8 N-m) *Fender tip lamp, front*
2. See Figure 8-60. Route harness through trim strip behind tee bolt, and through oblong hole (5).
  3. Secure trim strip with two nuts. Tighten.  
Torque: 10-15 **in-lbs** (1.1-1.7 N-m) *Fender trim strips, front*
  4. See Figure 8-59. Route harness between fender and fender mounting bracket (1).
  5. Route harness out through grommet.
  6. Install connector housing. See the electrical diagnostic manual.

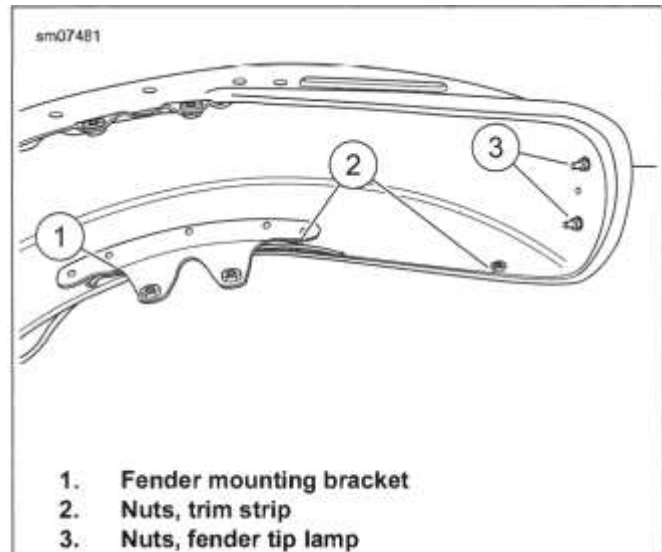


Figure 8-59. Front Fender Underside

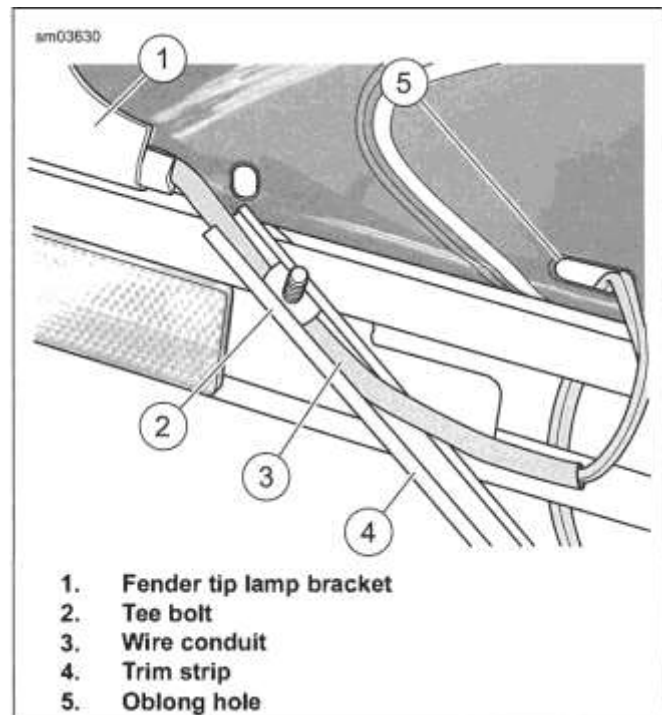


Figure 8-60. Install Conduit in Trim Strip

## COMPLETE

1. Install front fender. See FRONT FENDER (Page 3-134).
2. Install outer fairing. See FAIRING: FORK MOUNTED (Page 3-89).
3. Install main fuse. See POWER DISCONNECT (Page 8-8).
4. Install left side cover. See LEFT SIDE COVER (Page 3-62).

**A WARNING**

5. Verify correct operation of all lamps.

**Be sure that all lights and switches operate properly before operating motorcycle. Low visibility of rider can result in death or serious injury. (00316a)**

## GENERAL

Remove tour-pak mounted turn signals: See TOUR-PAK LIGHTING (Page 8-62).

## BULB REPLACEMENT

For bullet and flat lens styles, see Bulb Replacement in FRONT TURN SIGNAL LAMPS (Page 8-49).

For tour-pak mounted style, see TOUR-PAK LIGHTING (Page 8-62).

## PREPARE

### Bullet Style

1. Remove left saddlebag. See SADDLEBAGS (Page 3-161).
2. Remove left side cover. See LEFT SIDE COVER (Page 3-62).
3. Remove main fuse. See POWER DISCONNECT (Page 8-8).

### Flat Lens Style

1. Remove left saddlebag. If necessary, remove right saddlebag. See SADDLEBAGS (Page 3-161).
2. Remove left side cover. See LEFT SIDE COVER (Page 3-62).
3. Remove main fuse. See POWER DISCONNECT (Page 8-8).
4. Remove tail lamp assembly. See TAIL LAMP (Page 8-59).

### Tour-Pak Style

See TOUR-PAK LIGHTING (Page 8-62).

## REMOVE AND INSTALL: BULLET STYLE

| FASTENER                                | TORQUE VALUE  |              |
|---|---------------|--------------|
| License plate bracket screws            | 60-80 in-lbs  | 6.8-9 N-m    |
| Turn signal lamps bracket, rear, screws | 84-144 in-lbs | 9.5-16.3 N-m |

| PART NUMBER | CONSUMABLE   |
|-------------|--|
| 94759-99    | LOCTITE 262 HIGH STRENGTH THREADLOCKER AND SEALANT (RED) |

### Remove

#### NOTE

- Individual LEDs cannot be replaced. Replace assembly upon failure.

1. Models with tail lamp:
  - a. Release connectors from circuit board. See TAIL LAMP (Page 8-59).
  - b. Remove terminals from turn signal lamp connector housing. See the electrical diagnostic manual.
  - c. Release harness from cable clip inside fender.
  - d. Draw harness and terminals through hole to outboard side of fender.
2. Models without tail lamp:
  - a. Remove turn signal lamps bracket. See Remove Lamps Bracket Assembly in this section.
  - b. Remove grommet from harness.
  - c. Remove license plate bracket.
  - d. Remove screws securing license plate lamp.
  - e. Remove terminals from connector housing. See the electrical diagnostic manual.
  - f. Pull wires through main conduit.

### Install

1. Models with tail lamp:
  - a. Install new terminals onto wires. See the electrical diagnostic manual.
  - b. Feed terminals through hole to inboard side of fender.
  - c. Install terminals into connector housing. See the electrical diagnostic manual.
  - d. Capture harness in cable clip inside fender.
  - e. Install connectors onto circuit board.
2. Models without tail lamp:
  - a. Feed wires through main conduit. Install new terminals and install in connector housing. See the electrical diagnostic manual.
  - b. Route both turn signal lamp harnesses under license plate lamp area. Install license plate lamp and license plate bracket.
  - c. Install turn signal lamps bracket. See Install Lamps Bracket Assembly in this section.
3. Check operation of all lamps.



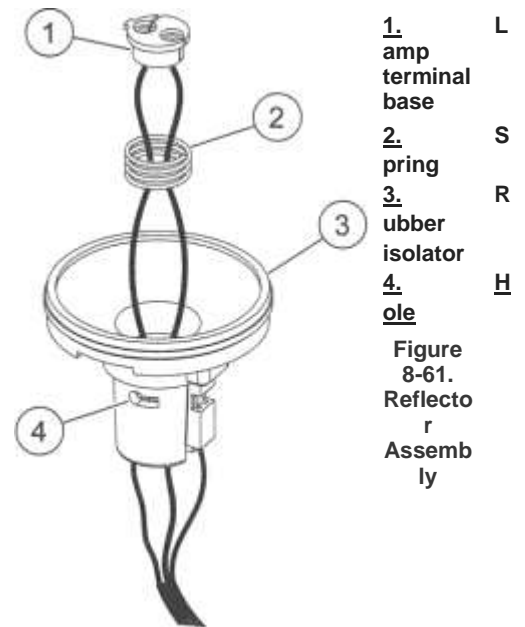
## Lamp Repair

### NOTE

LED type lamps are not serviced separately. Replace light bar assembly.

1. Remove lens and bulb.
2. Push grommet into lamp housing. Lubricate parts with glass cleaner or isopropyl alcohol.
3. See Figure 8-61. Insert a right angle pick or a small hex key from inside the bulb socket through hole (4). Pull reflector from lamp.
4. Remove rubber isolator (3).
5. Place **new** reflector assembly next to discarded unit and cut wires to proper length.
6. Seat reflector assembly in rubber isolator, aligning tab on reflector with slot in isolator.
7. Feed wires through lens opening and out through hole in lamp housing.
8. Install grommet in lamp housing. Lubricate parts with glass cleaner or isopropyl alcohol.
9. Align tab on reflector with slot inside lamp.
10. Use thumbs of both hands to apply even pressure around outer edge of reflector assembly until fully seated.
11. Liberally apply dielectric grease to contacts in socket and at bottom of bulb.
12. Install bulb and lens with slot at bottom of lamp.

sm06184



## Remove Lamps Bracket Assembly

### 1. Models with tail lamp:

- a. See Figure 8-62. Release turn signal lamp harnesses (4) from cable clips.
- b. Remove terminals from license plate lamp connector. See the electrical diagnostic manual.

### 2. Models without tail lamp:

- a. See Figure 8-63. Disconnect turn signal connector (3) from rear fascia lamp.
- b. Release harness from J-clamp (2) located above fascia lamp.
- c. Push grommet (1) rearward out of hole in fender.

3. Remove two screws to release rear turn signal lamps bracket. Remove bracket and harnesses.

4. Remove screws to release license plate bracket and lamp from turn signal bracket.

## Install Lamps Bracket Assembly

1. Install license plate lamp and bracket onto turn signal bracket. Tighten.

Torque: 60-80 **in-lbs** (6.8-9 N-m) *License plate bracket screws*

2. **Models with tail lamp:** Feed connectors of rear turn signal lamps and license plate light through respective holes to inboard side of fender.

3. Models without tail lamp:
  - a. See Figure 8-64. Install grommet (1) and orient as shown.
  - b. Route harness through hole in fender and seat grommet in hole.
4. Apply one drop of high strength threadlocker to screws.  
Consumable: LOCTITE 262 HIGH STRENGTH THREADLOCKER AND SEALANT (RED) (94759-99)
5. Install rear turn signal lamps bracket. Tighten.  
Torque: 84-144 in-lbs (9.5-16.3 N-m) *Turn signal lamps bracket, rear, screws*
6. Models with tail lamp:
  - a. Install terminals into license plate lamp connector. See the electrical diagnostic manual.
7. Models without tail lamp:
  - a. See Figure 8-63. Install connector (3).
  - b. Secure harness in J-clamp (2) and under tab on end of fascia lamp.

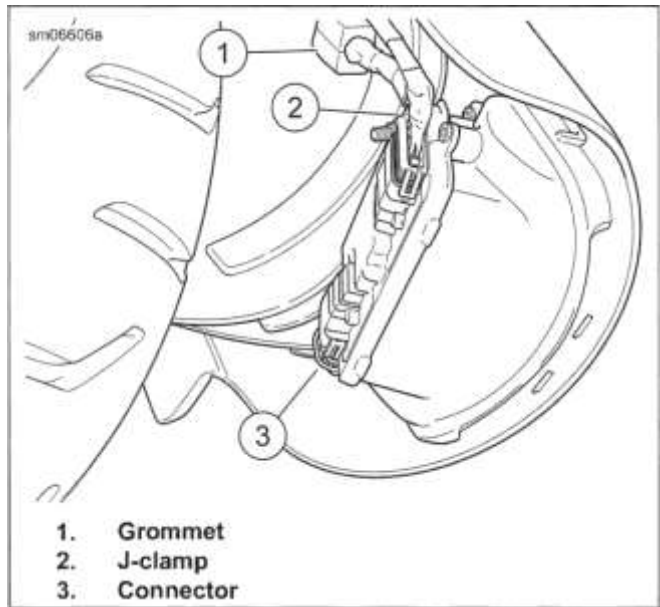


Figure 8-63. Rear Turn Signal Lights Connector (models without tail lamp)

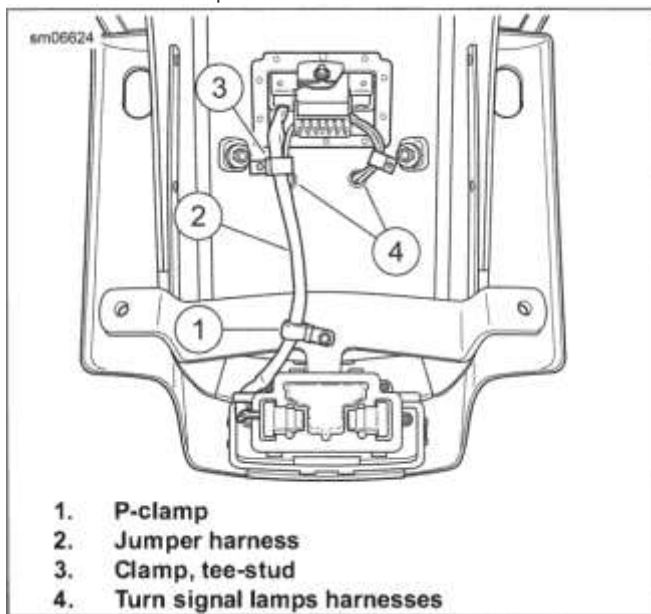


Figure 8-62. Tail Lamp Jumper Harness (models with tail lamp)

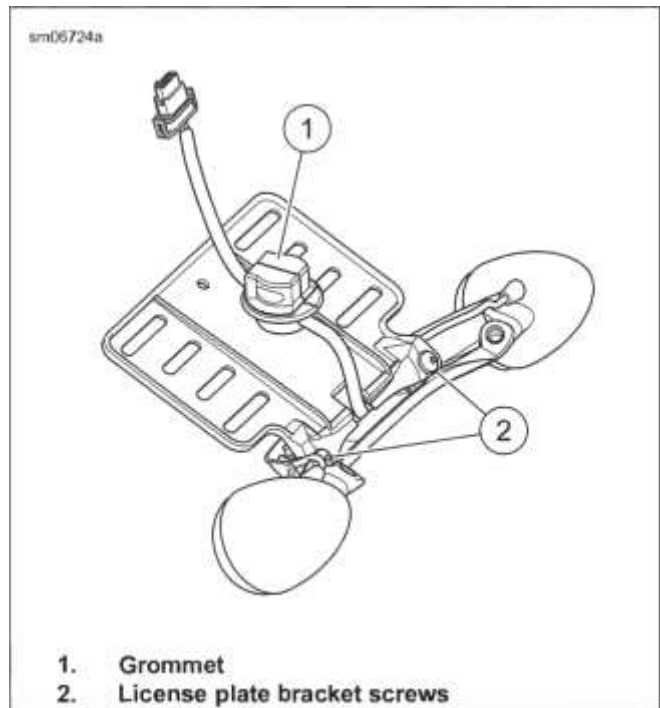


Figure 8-64. Rear Turn Signal Lamps and Harness (models without tail lamp)

**REMOVE AND INSTALL: FLAT LENS STYLE**

| FASTENER                           | TORQUE VALUE  |              |
|------------------------------------|---------------|--------------|
| License plate bracket screws       | 60-80 in-lbs  | 6.8-9 N-m    |
| Rear lightbar screw                | 84-120 in-lbs | 9.5-13.6 N-m |
| Rear turn signal to lightbar screw | 30-50 in-lbs  | 3.4-5.6 N-m  |

| PART NUMBER | CONSUMABLE   |
|-------------|--|
| 94759-99    | LOCTITE 262 HIGH STRENGTH THREADLOCKER AND SEALANT (RED) |

## Lightbar Assembly Remove

### 1. NOTE

Use a pick or small screwdriver to press latch.

See Figure 8-65 and Figure 8-66. Disconnect both turn signal lamp connectors.

2. Feed connectors to inboard side of rear fender.
3. Release harnesses from cable clips inside fender.
4. Draw out harnesses and connectors through fender holes (2).
5. Remove lightbar mounting screws.
6. Separate lightbar assembly from fender.
7. Remove screws to release license plate bracket and lamp from lightbar.

## Install

1. Install license plate lamp and bracket onto lightbar. Tighten.  
Torque: 60-80 in-lbs (6.8-9 N-m) *License plate bracket screws*
2. If necessary, install new bushings in fender holes.
3. Feed harnesses through bushings.
4. Apply high strength threadlocker to mounting screws.  
Consumable: LOCTITE 262 HIGH STRENGTH THREADLOCKER AND SEALANT (RED) (94759-99)
5. Attach lightbar to fender with screws. Tighten.  
Torque: 84-120 in-lbs (9.5-13.6 N-m) *Rear lightbar screw*
6. Route harnesses through tail lamp base holes.
7. See Figure 8-65. Connect both turn signal lamp connectors.
8. Insert harnesses in cable clips inside fender.

5. Draw connector through channel on lightbar.
6. Remove two screws to release turn signal lamp assembly.

## Install

1. Feed connector through hole in end of lightbar.
2. Install two screws to mount lamp to lightbar. Tighten.  
Torque: 30-50 in-lbs (3.4-5.6 N-m) *Rear turn signal to lightbar screw*
3. Route connector through lightbar and fender hole (2).
4. Route wire out through tail lamp base.
5. See Figure 8-65. Install connector in correct location.
6. Insert harness in cable clip inside fender.

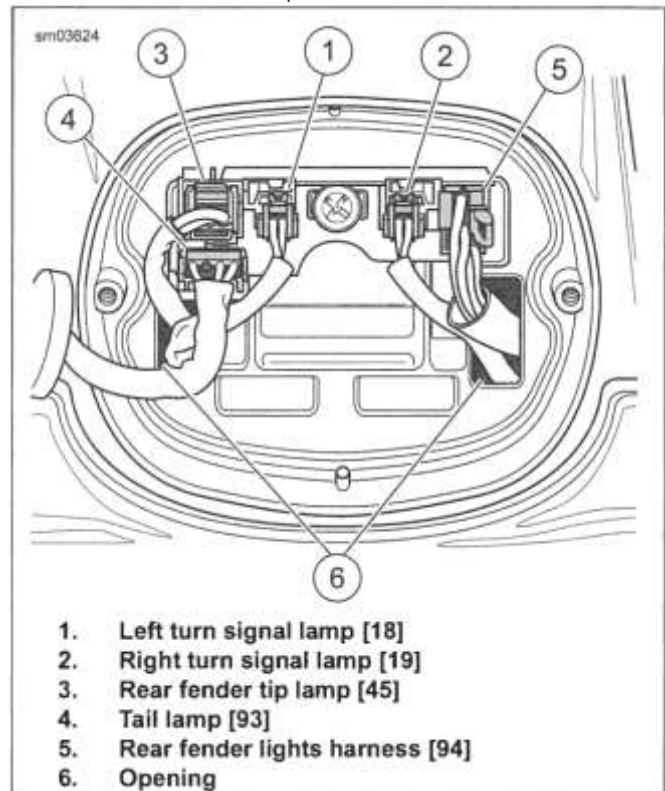


Figure 8-65. Rear Fender Lights Connectors

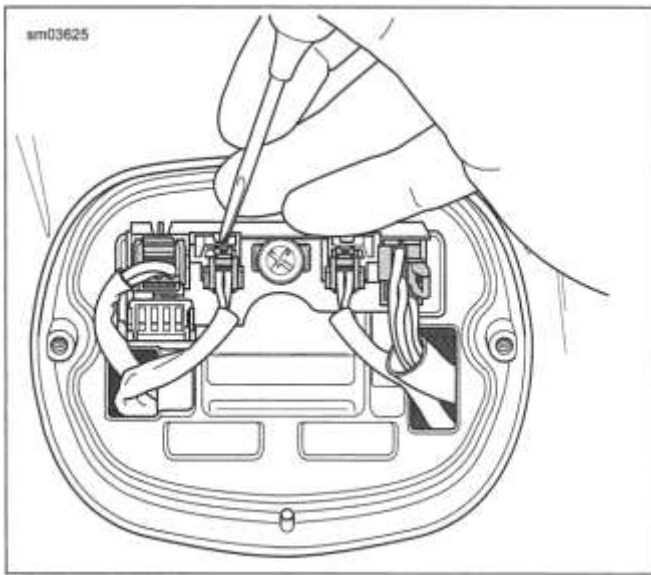
## Turn Signal Lamp Remove

### 1. NOTE

Use a pick or small screwdriver to press latch.

See Figure 8-65 and Figure 8-66. Disconnect appropriate turn signal lamp connector.

2. Feed connector to inboard side of rear fender.
3. Release harness from cable clip inside fender.
4. Draw out harness and connector through fender hole (2).



**Figure 8-66. Use Pick Tool to Release Turn Signal Lamp Socket**

2. Test light function.

## **COMPLETE**

### **Bullet Style**

1. Install main fuse. See POWER DISCONNECT (Page 8-8).
3. Install left side cover. See LEFT SIDE COVER (Page 3-62).
4. Install left saddlebag. See SADDLEBAGS (Page 3-161).

### **Flat Lens Style**

1. Install tail lamp assembly. See TAIL LAMP (Page 8-59).
2. Install main fuse. See POWER DISCONNECT (Page 8-8).
3. Test light function.
4. Install left side cover. See LEFT SIDE COVER (Page 3-62).
5. Install removed saddlebags. See SADDLEBAGS (Page 3-161).

## BULB REPLACEMENT

| FASTENER         | TORQUE VALUE |             |
|------------------|--------------|-------------|
| Tail lamp screws | 20-24 in-lbs | 2.3-2.7 N-m |

| PART NUMBER | CONSUMABLE                   |
|-------------|------------------------------|
| 11300004    | ELECTRICAL CONTACT LUBRICANT |

For bullet style brake lights, see FRONT TURN SIGNAL LAMPS (Page 8-49).

### Remove

1. Remove two screws to release tail lamp assembly from chrome base.
2. See Figure 8-67. Disconnect tail lamp connector (3).
3. Rotate bulb socket (4) a quarter turn counterclockwise and remove from tail lamp assembly.
4. Remove bulb.

### Install

1. Coat base of **new** bulb with electrical contact lubricant.  
Consumable: ELECTRICAL CONTACT LUBRICANT (11300004)
2. Install **new** bulb.
3. See Figure 8-67. Insert socket (4) into tail lamp assembly. Rotate a quarter turn clockwise.
4. Attach tail lamp connector (3).
5. Place tail lamp into position against chrome base.
6. Install two screws. Tighten.  
Torque: 20-24 **in-lbs** (2.3-2.7 N-m) *Tail lamp screws*

### A WARNING

Be sure that all lights and switches operate properly before operating motorcycle. Low visibility of rider can result in death or serious injury. (00316a)

7. Check operation of all lamps.

## PREPARE

### Bullet Style Lights

See REAR TURN SIGNAL LAMPS (Page 8-54).

### Standard Tail Lamp

1. Remove left saddlebag. See SADDLEBAGS (Page 3-161).
2. Remove left side cover. See LEFT SIDE COVER (Page 3-62).

3. Remove main fuse. See POWER DISCONNECT (Page 8-8).
4. Remove tail lamp assembly. See Bulb Replacement in this section.

## REMOVE

1. See Figure 8-69. Disconnect all connectors.
2. Remove screw at center of base.
3. Push base upward until it is free of fender and pull out of fender hole.
4. Remove pin housing and circuit board from base.

## INSTALL

1. See Figure 8-68. Feed connectors through openings in base.

| FASTENER             | TORQUE VALUE        |             |
|----------------------|---------------------|-------------|
| Tail lamp base screw | 40-48 <b>in-lbs</b> | 4.5-5.4 N-m |

For best results, feed larger socket housings first.

2. Fit bottom of base into fender hole and push down.
3. See Figure 8-70. Install pin housing/circuit board with screw. Tighten.  
Torque: 40-48 **in-lbs** (4.5-5.4 N-m) *Tail lamp base screw*
4. Install connectors into circuit board.
5. See Figure 8-67. Verify tail lamp harness is routed as shown.

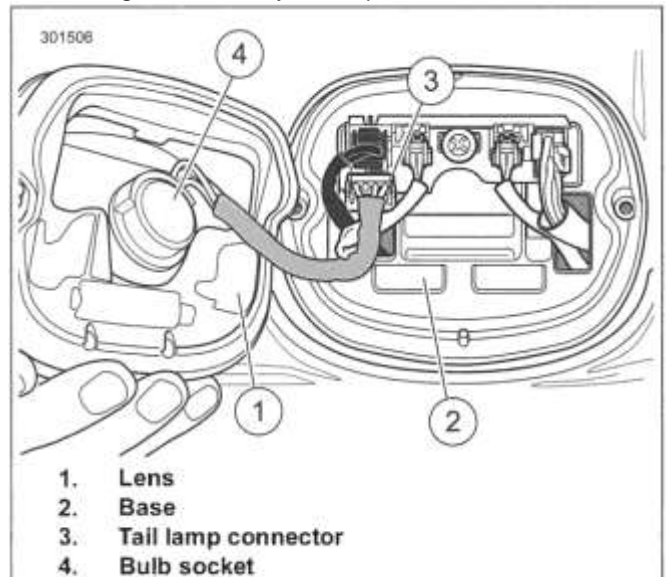
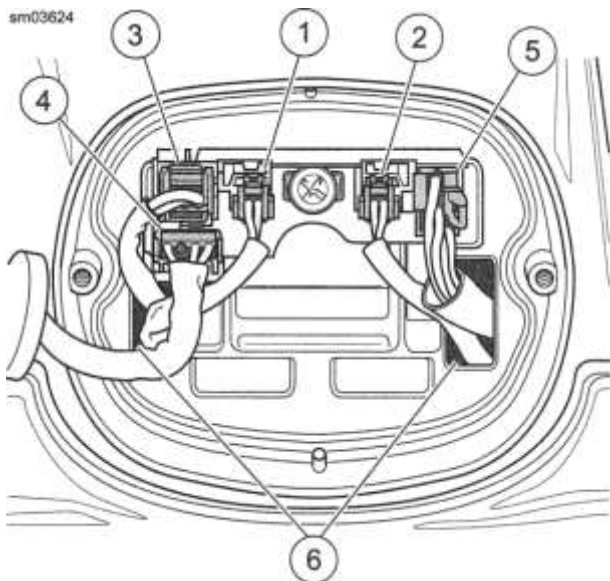


Figure 8-67. Tail Lamp Assembly



1. Left turn signal lamp [18]
  2. Right turn signal lamp [19]
  3. Rear fender tip lamp [45]
  4. Tail lamp [93]
  5. Rear fender lights harness [94]
  6. Opening
- Figure 8-68. Rear Fender Lights Connectors

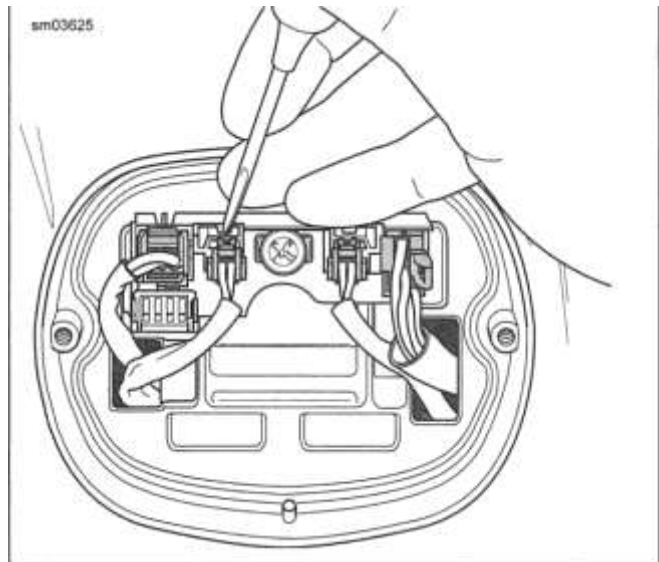


Figure 8-69. Use Pick Tool to Release Turn Signal Lamp Socket

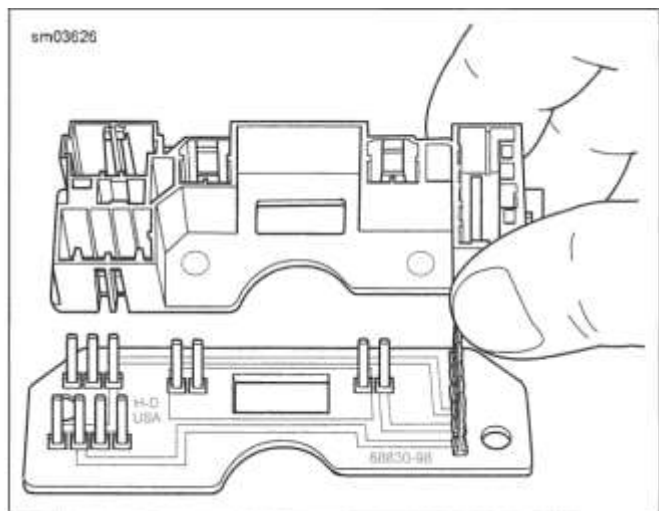


Figure 8-70. Place Pin Housing Over Circuit Board

**COMPLETE**

1. See Bulb Replacement in this section.

## PREPARE

1. Remove left side saddlebag. See SADDLEBAGS (Page 3-161).
2. Remove left side cover. See LEFT SIDE COVER (Page 3-62).
3. Remove main fuse. See POWER DISCONNECT (Page 8-8).

## REMOVE AND INSTALL: FASCIA LAMP

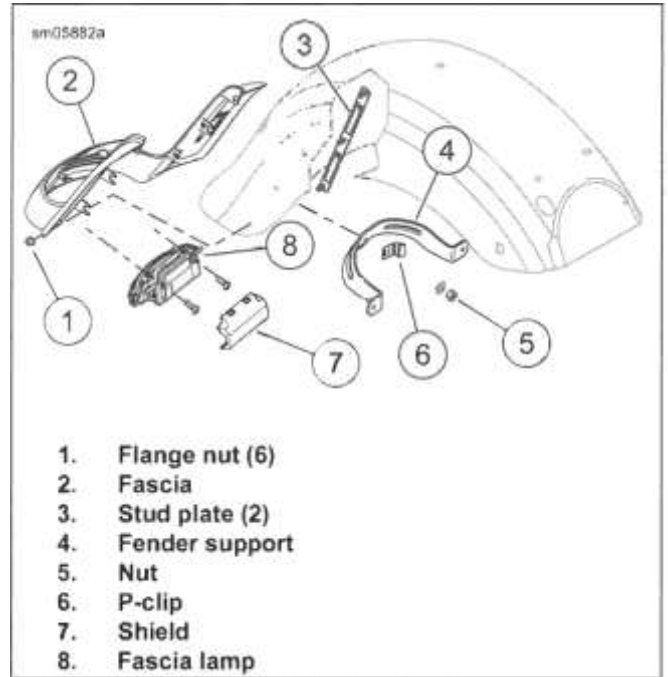
| FASTENER          | TORQUE VALUE |           |
|-------------------|--------------|-----------|
| Fascia lamp screw | 18-22 in-lbs | 2-2.5 N-m |

### Remove

1. See Figure 8-71. Remove shield (7).
2. Disconnect rear lights harness and tail light jumper harness from fascia lamp.
3. Remove screws securing lamp (8).

### Install

1. See Figure 8-71.
2. Secure lamp (8) with two screws. Tighten.  
Torque: 18-22 in-lbs (2-2.5 N-m) *Fascia lamp screw*
3. Connect rear lights harness and tail lamp jumper harness to fascia lamp.
4. Install shield (7).



1. Flange nut (6)
2. Fascia
3. Stud plate (2)
4. Fender support
5. Nut
6. P-clip
7. Shield
8. Fascia lamp

Figure 8-71. Rear Fascia

## COMPLETE

1. Install main fuse. See POWER DISCONNECT (Page 8-8).
2. Test lamp operation.
3. Install left side cover. See LEFT SIDE COVER (Page 3-62).
4. Install left saddlebag. See SADDLEBAGS (Page 3-161).

**PREPARE**

1. Remove left saddlebag. See SADDLEBAGS (Page 3-161).
2. Remove left side cover. See LEFT SIDE COVER (Page 3-62).
3. Remove main fuse. See POWER DISCONNECT (Page 8-8).
4. Remove Tour-Pak liner. See TOUR-PAK (Page 3-153).

**REMOVE AND INSTALL: SIDE LAMPS/TRIM STRIPS**

| FASTENER                        | TORQUE VALUE |             |
|---------------------------------|--------------|-------------|
| Ground plate/marker lamp screws | 20-25 in-lbs | 2.3-2.8 N-m |

**Remove**

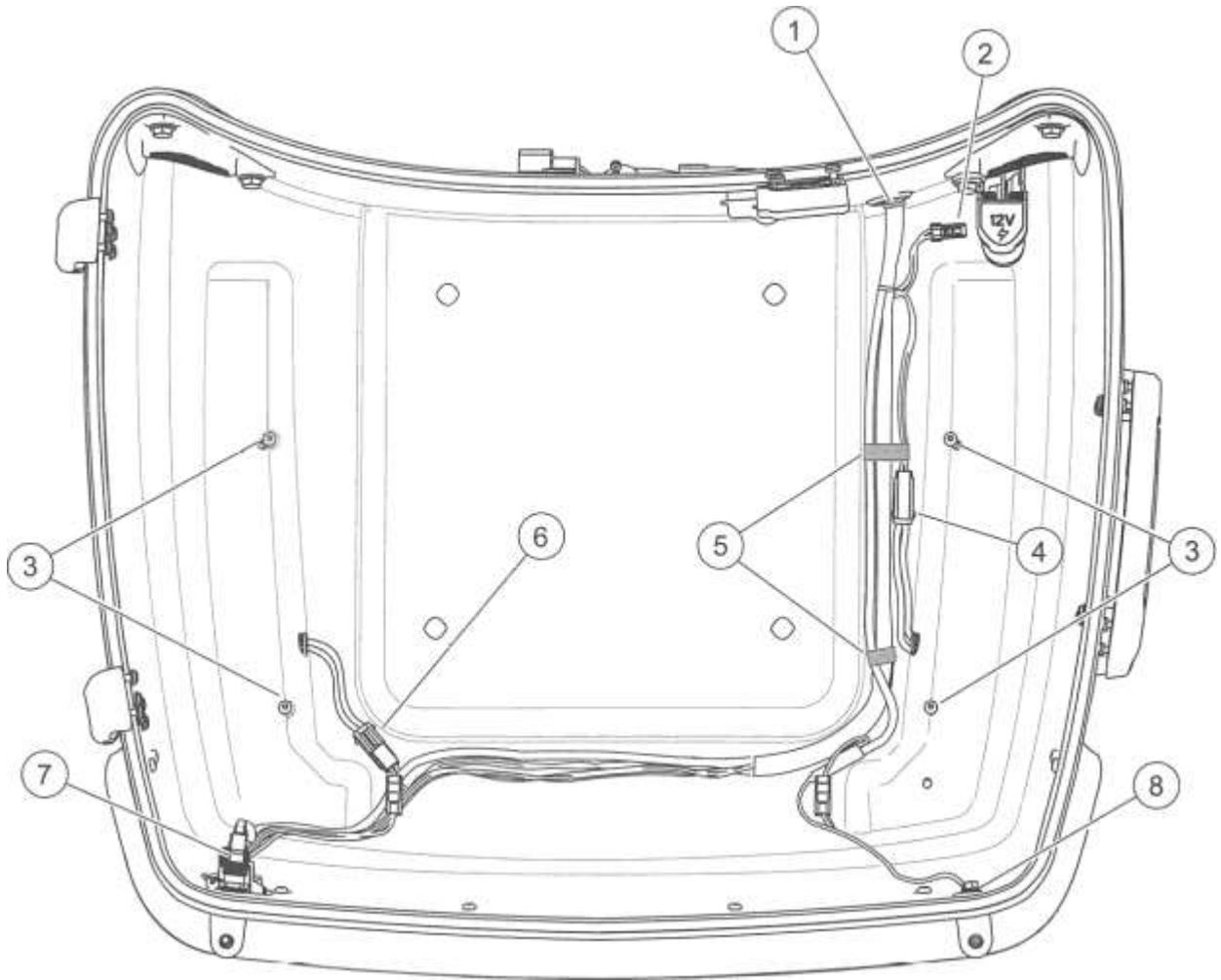
1. Remove Tour-Pak. See TOUR-PAK (Page 3-153).
2. See Figure 8-72. Remove four screws (3) securing ground plate and marker lamps/trim strips.
3. Disconnect two ground connectors.

4. Remove ground plate.
5. Lamp equipped:
  - a. Disconnect side marker lamp connector (4 or 6).
  - b. Remove split bushing.
  - c. Pull harness and connector through hole.

**Install**

1. Lamp equipped:
  - a. See Figure 8-72. Feed connector through hole in Tour-Pak and place side marker lamp into position.
  - b. Install split bushing.
  - c. Connect side marker lamp connector (4 or 6).
2. While holding lamps or trim strips in position, install ground plate with four screws (3). Tighten.  
Torque: 20-25 in-lbs (2.3-2.8 N-m) *Ground plate/marker lamp screws*
3. Attach two ground connectors to ground plate.
4. Install Tour-Pak. See TOUR-PAK (Page 3-153).





- |                                    |                               |
|------------------------------------|-------------------------------|
| 1. Cable strap                     | 5. Tape                       |
| 2. Power outlet connector          | 6. Left marker lamp connector |
| 3. Ground plate/marker lamp screws | 7. Radio antenna cable        |
| 4. Right marker lamp connector     | 8. CB antenna cable           |

Figure 8-72. Tour-Pak Harness

**REMOVE AND INSTALL: WRAP-AROUND LAMP****Remove**

| FASTENER                           | TORQUE VALUE |             |
|------------------------------------|--------------|-------------|
| AM/FM antenna stud nut             | 16-19 in-lbs | 1.8-2.1 N-m |
| CB antenna base set screw          | 14-16 in-lbs | 1.6-1.8 N-m |
| CB antenna stud nut                | 14-16 in-lbs | 1.6-1.8 N-m |
| Radio antenna base inner set screw | 14-16 in-lbs | 1.6-1.8 N-m |
| Wrap-around lamp screws            | 20-25 in-lbs | 2.3-2.8 N-m |

1. Remove antenna masts from lamp housing.
2. See Figure 8-73. Disconnect radio antenna cable connector (3).

3. Disconnect electrical connector (4).
4. Disconnect CB antenna cable connector if equipped.
5. Remove nut (5), washer and ring terminal from CB antenna stud.
6. Remove nut (2), ring terminal and large flat washer from AM/FM radio antenna stud.
7. Remove eight screws (1) to free lamp assembly from Tour-Pak.

**Repair**

1. Remove CB antenna stud.

2. Remove antenna base from lamp housing.
  - a. Using the original nut and a 1/2 in.-20 UNF nut as a jamnut, remove connector stud from radio antenna base.
  - b. Remove inner stud and remove antenna base from lamp housing.

3. Install radio antenna base with inner set screw. Tighten.
 

Torque: 14-16 in-lbs (1.6-1.8 N-m) *Radio antenna base inner set screw*

4. Install radio antenna connector stud.
  - a. Tighten securely.
  - b. Remove nuts.

5. Install CB antenna base into lamp housing and secure with set screw, if equipped. Tighten.
 

Torque: 14-16 in-lbs (1.6-1.8 N-m) *CB antenna base set screw*

**Install**

1. See Figure 8-73. Install lamp using screws (1). Tighten.
 

Torque: 20-25 in-lbs (2.3-2.8 N-m) *Wrap-around lamp screws*

2. Install electrical connector (4).

3. Install AM/FM radio antenna stud.
  - a. Install large flat washer and ring terminal onto antenna stud.
  - b. Install nut (2) onto antenna stud.
  - c. Tighten.
 

Torque: 16-19 in-lbs (1.8-2.1 N-m) *AM/FM antenna stud nut*

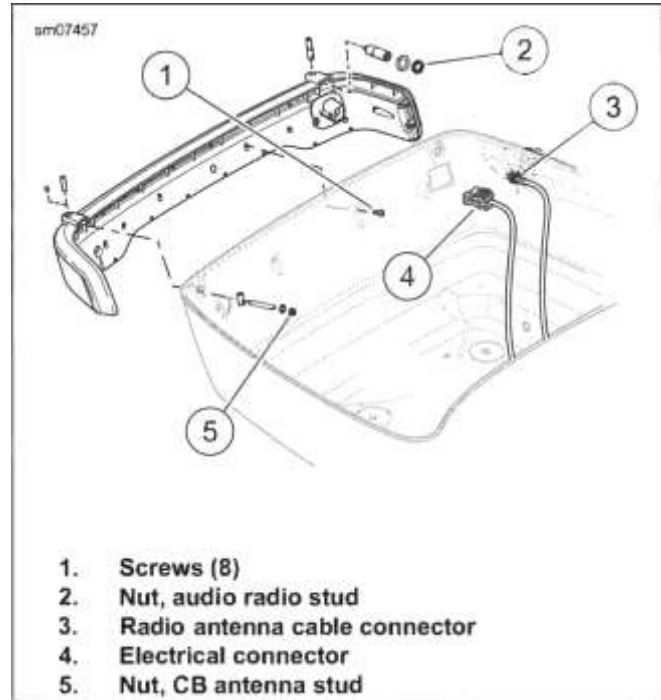
4. Connect AM/FM radio antenna cable connector (3).

5. Install CB antenna stud.
  - a. Install ring terminal and flat washer onto antenna stud.

- b. Install nut (5) onto antenna stud.
  - c. Tighten.
 

Torque: 14-16 in-lbs (1.6-1.8 N-m) *CB antenna stud nut*
6. Connect CB antenna cable, if equipped.
7. Install antenna masts in lamp housing.

**COMPLETE**



**Figure 8-73. Wrap-around Lamp**

1. Install Tour-Pak liner. See TOUR-PAK (Page 3-153).
2. Install main fuse. See POWER DISCONNECT (Page 8-8).
3. Install left side cover. See LEFT SIDE COVER (Page 3-62).
4. Install left saddlebag. See SADDLEBAGS (Page 3-161).

## PREPARE

1. Remove left saddlebag. See SADDLEBAGS (Page 3-161).
2. Remove left side cover. See LEFT SIDE COVER (Page 3-62).
3. Remove main fuse. See POWER DISCONNECT (Page 8-8).
4. Remove right side rider footboard. See RIDER FOOTRESTS (Page 3-142).

5. *NOTE Do not disconnect brake line.*

Remove rear brake master cylinder from frame. See REAR BRAKE MASTER CYLINDER (Page 3-42).

## REMOVE COMPLETE

1. See Figure 8-74. Disconnect stop lamp switch connectors from terminals (1).

2. *NOTE*

*Wrap switch fitting with pieces of lint-free shop towel to absorb any loss of brake fluid.*

Hold brake line fitting (3) and remove rear stop lamp switch (2).

| FASTENER              | TORQUE VALUE |          |
|-----------------------|--------------|----------|
| Rear stop lamp switch | 144 in-lbs   | 16.3 N-m |

| PART NUMBER | CONSUMABLE                 |
|-------------|----------------------------|
| 99818-97    | LOCTITE 565 THREAD SEALANT |

## INSTALL

1. Apply thread sealant to rear stop lamp switch.  
Consumable: LOCTITE 565 THREAD SEALANT (99818-97)
2. See Figure 8-74. Install rear stop lamp switch (2) into rear brake line fitting (3).
3. Hold brake line fitting and tighten.  
Torque: 144 in-lbs (16.3 N-m) *Rear stop lamp switch*
4. Install stop lamp switch connectors on terminals (1).

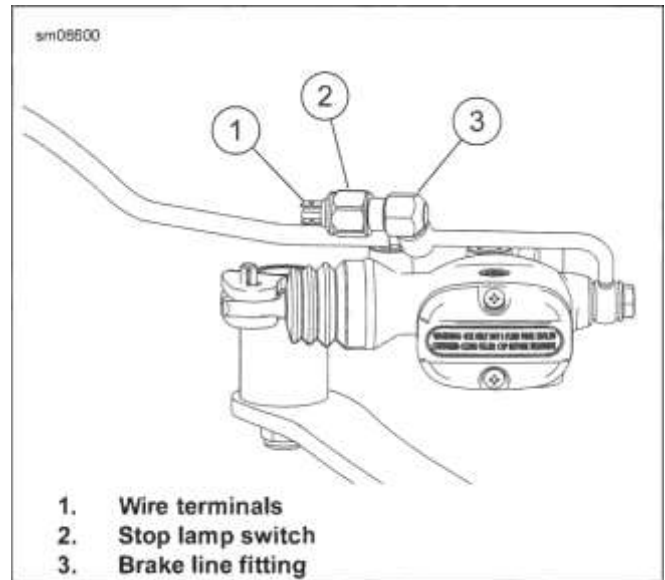


Figure 8-74. Rear Stop Lamp Switch

1. *NOTE*

*Do not disconnect brake line.*

Install rear brake master cylinder. See REAR BRAKE MASTER CYLINDER (Page 3-42).

a. Confirm oil switch/sender wires are inboard of rubber mount.

2. Install right side rider footboard. See RIDER FOOTRESTS (Page 3-142).
3. Bleed brake system. See BLEED BRAKES (Page 3-60).
4. Install main fuse. See POWER DISCONNECT (Page 8-8).

## A WARNING

Be sure that all lights and switches operate properly before operating motorcycle. Low visibility of rider can result in death or serious injury. (00316a)

5. Verify tail lamp and stop lamp operation.
6. Install left side cover. See LEFT SIDE COVER (Page 3-62).
7. Install left saddlebag. See SADDLEBAGS (Page 3-161).

**GENERAL** \_\_\_\_\_ 2. **Turn signal bracket mounted license:** See REAR TURN SIGNAL LAMPS (Page 8-54).

1. **Tour-Pak support mounted license:** See TAIL LAMP (Page 8-59).

**PREPARE**

1. Remove left saddlebag. See SADDLEBAGS (Page 3-161).
2. Remove left side cover. See LEFT SIDE COVER (Page 3-62).
3. Remove main fuse. See POWER DISCONNECT (Page 8-8).
4. Remove outer fairing and windshield. See FAIRING: FORK MOUNTED (Page 3-89) or FAIRING: FRAME MOUNTED (Page 3-100).
5. Fork-mounted fairing:
  - a. Remove fairing vent bezel. See Remove and Install: Vent Bezel in FAIRING: FORK MOUNTED (Page 3-89).
  - b. Remove upper support bracket. See Remove and Install: Upper Support Bracket in FAIRING: FORK MOUNTED (Page 3-89).
  - c. Remove instrument cluster. See FAIRING GAUGES (Page 8-34).

3.

Pull radio up and forward to remove.

4. **NOTE**  
The XM module is very fragile and is sensitive to static discharge.

XM equipped:

- a. Remove screws securing XM module in radio frame.
- b. Transfer XM module to new radio immediately. If new radio is not available, store XM module in static proof bag.
- c. Tighten screw securely.

**Install**

1. **NOTE**  
Verify foam tape is in place on inner fairing near radio opening.

Position radio on fairing support brackets and push toward opening in inner fairing.

2. See Figure 8-76. Loosely install four screws (1).
3. Install instrument cluster. See FAIRING GAUGES (Page 8-34).
4. Install upper support bracket (3). See Remove and Install: Upper Support Bracket in FAIRING: FORK MOUNTED (Page 3-89).
5. See Figure 8-76. Tighten screws (1).  
Torque: 60-84 in-lbs (6.8-9.5 N-m) *Radio-to-upper support bracket screw*

6. **NOTE**  
Some connectors are not used on all models.

See Figure 8-75. Mate connectors:

- a. Radio harness connector (6).
- b. USB connector (5).
- c. AM/FM antenna cable connector (4).
- d. GPS connector (3).
- e. SiriusXM connector (2) (if equipped).

**REMOVE AND INSTALL: FORK MOUNTED FAIRING**

| FASTENER                             | TORQUE VALUE |             |
|--------------------------------------|--------------|-------------|
| Radio-to-upper support bracket screw | 60-84 in-lbs | 6.8-9.5 N-m |

**Remove**

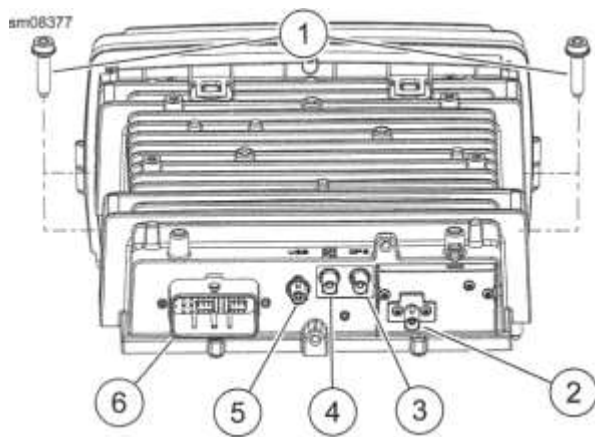
**NOTE**

Never operate vehicle with the radio or upper support bracket removed. These components provide important structural support to the fairing. Temporarily install a Police glove box assembly if the vehicle must be operated while the radio is removed. Damage to the fairing assembly can result if operated without either of these components installed.

1. **NOTE**  
Some connectors are not used on all models.

See Figure 8-75. Disconnect:

- a. Radio harness connector (6).
  - b. USB connector (5).
  - c. AM/FM antenna cable connector (4).
  - d. GPS connector (3).
  - e. SiriusXM connector (2) (if equipped).
2. See Figure 8-76. Remove four screws (1) to release radio (2) from fairing support brackets.



1. Screws, radio mounting (4)
2. SiriusXM connector
3. GPS connector
4. AM/FM antenna connector
5. USB connector
6. Radio harness connector

Figure 8-75. Radio: Fork Mounted Fairing Models

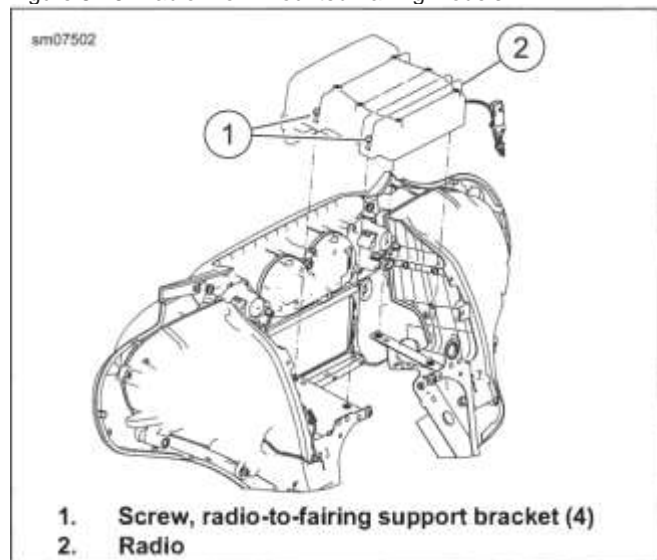


Figure 8-76. Remove Radio from Fairing Brackets

## REMOVE AND INSTALL: FRAME MOUNTED FAIRING

| FASTENER                                | TORQUE VALUE |             |
|---|--------------|-------------|
| Radio to fairing support bracket screws | 60-84 in-lbs | 6.8-9.5 N-m |
| Radio upper bracket: FLTR               | 25-35 in-lbs | 2.8-4 N-m   |

### NOTE

Never operate vehicle with the radio or upper support bracket removed. These components provide important structural support to the fairing. Damage to the fairing assembly can result if operated without these components installed.

1. **NOTE**  
Some connectors are not used on all models.

See Figure 8-77. Disconnect:

- a. Radio harness connector (8).

- b. USB connector (7).
  - c. AM/FM antenna cable connector (6).
  - d. GPS connector (5).
  - e. SiriusXM connector (4) (if equipped).
2. If required, remove two screws (1) and upper support bracket (2).
  3. Remove four screws (2) to release radio from fairing support bracket.
  4. Pull radio up and forward to remove.

5. **NOTE**  
The XM module is very fragile and is sensitive to static discharge.

XM equipped:

- a. Remove screws securing XM module in radio frame.
- b. Transfer XM module into new radio immediately. If new radio is not available, store XM module in static proof bag.
- c. Tighten screw securely.

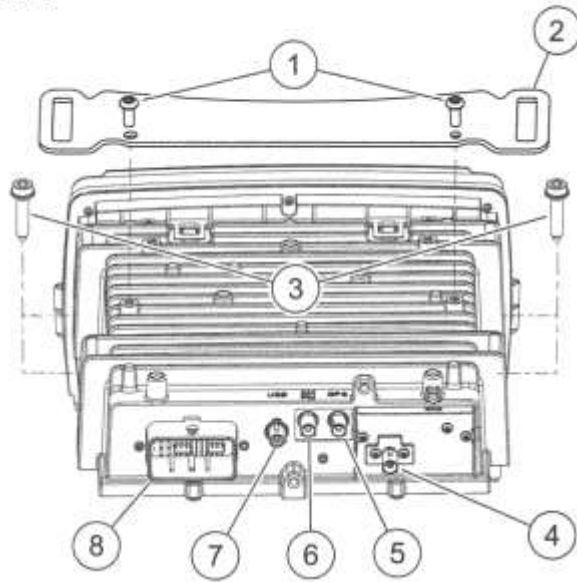
### Install

1. Position radio on fairing support bracket and push toward opening in inner fairing.
2. See Figure 8-77. Install four screws (2). Tighten.  
Torque: 60-84 in-lbs (6.8-9.5 N-m) *Radio to fairing support bracket screws*
3. If removed, install upper radio bracket (2) with screws (1). Tighten.  
Torque: 25-35 in-lbs (2.8-4 N-m) *Radio upper bracket: FLTR*
4. **NOTE**  
Some connectors are not used on all models.

Mate connectors:

- a. Radio harness connector (8).
- b. SB connector (7).
- c. AM/FM antenna cable connector (6).
- d. GPS connector (5).
- e. SiriusXM connector (4) (if equipped).

U



1. Screw, air duct bracket (2)
2. Upper support bracket
3. Screw, radio mounting (4)
4. SiriusXM connector (if equipped)
5. GPS connector
6. AM/FM antenna connector
7. USB connector
8. Radio harness connector

Figure 8-77. Radio: Frame Mounted Fairing Models

### **COMPLETE**

| PART NUMBER | TOOL NAME             |
|-------------|-----------------------|
| HD-48650    | DIGITAL TECHNICIAN II |

1. Fork-mounted fairing: Install fairing vent bezel. See Remove and Install: Vent Bezel in FAIRING: FORK MOUNTED (Page 3-89).

2. Install outer fairing and windshield. See FAIRING: FORK MOUNTED (Page 3-89) or FAIRING: FRAME MOUNTED (Page 3-100).
3. Install main fuse. See POWER DISCONNECT (Page 8-8).
4. Install left side cover. See LEFT SIDE COVER (Page 3-62).
5. Install left saddlebag. See SADDLEBAGS (Page 3-161).
6. If installing a new radio, it must be set up:  
Special Tool: DIGITAL TECHNICIAN II (HD-48650)

#### **NOTE**

*Instructions to check, download and install software are available in PDF format at [www.harley-davidson.com/softwaredownloads](http://www.harley-davidson.com/softwaredownloads).*

- a. Choose the REFLASH icon.
  - b. Follow the on-screen prompts. If the vehicle has an amplifier, it must be configured after configuring the radio.
7. Check software version:
    - a. Visit [www.harley-davidson.com/softwaredownloads](http://www.harley-davidson.com/softwaredownloads).
    - b. Compare software version number to online version number.
    - c. If online version number is higher than displayed version number, download and install latest version.

## PREPARE

**NOTE**

Never operate vehicle with the speaker enclosures removed. These components provide important structural support to the fairing. Operating without these components can result in damage to fairing assembly.

1. Remove left saddlebag. See SADDLEBAGS (Page 3-161).
2. Remove left side cover. See LEFT SIDE COVER (Page 3-62).
3. Remove main fuse. See POWER DISCONNECT (Page 8-8).

## REMOVE AND INSTALL: FORK MOUNTED FAIRING

| FASTENER  | TORQUE VALUE |             |
|---|--------------|-------------|
| Fairing speaker enclosure to fairing screws         | 48-60 in-lbs | 5.4-6.8 N-m |
| Fairing speaker enclosure to fairing support screws | 48-60 in-lbs | 5.4-6.8 N-m |
| Fairing speaker grille screws                       | 9-13 in-lbs  | 1-1.5 N-m   |
| Fairing speaker screws                              | 9-13 in-lbs  | 1-1.5 N-m   |
| Upper support bracket to speaker enclosure screws   | 48-60 in-lbs | 5.4-6.8 N-m |

### Remove

1. Remove outer fairing. See FAIRING: FORK MOUNTED (Page 3-89).
2. Remove harness anchors from speaker enclosure.
3. See Figure 8-78. Disconnect speaker connector (7).
4. Right side: Disconnect power outlet connector.
5. Left side: Remove CB module if equipped. See CB MODULE (Page 8-78).
6. Remove three screws (1) securing enclosure to fairing support (6).
7. Remove two screws (2) securing enclosure to upper support bracket.

8. **NOTE**

Do not remove screws securing speaker enclosure halves together.

Remove three screws (8). Remove speaker enclosure from fairing.

9. Remove four screws to free speaker from enclosure.
10. Disconnect wires and remove speaker from enclosure.

11. If necessary, remove grommet and harness.

### Install

1. **NOTE**

Verify harness grommet is correctly installed. Incorrectly installed grommet can result in poor audio, whistling or a rattle.

If removed, install harness and grommet.

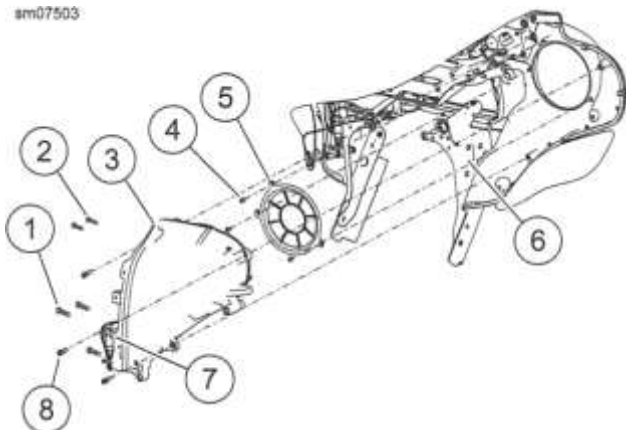
2. Attach speaker wire connectors.
3. Install speaker and secure with four screws. Tighten.  
Torque: 9-13 in-lbs (1-1.5 N-m) Fairing speaker screws
4. See Figure 8-78. Install speaker enclosure to inner fairing. Secure with three screws (8). Tighten.  
Torque: 48-60 in-lbs (5.4-6.8 N-m) Fairing speaker enclosure to fairing screws
5. Secure enclosure to fairing support (6) with three screws (1) . Tighten.  
Torque: 48-60 in-lbs (5.4-6.8 N-m) Fairing speaker enclosure to fairing support screws
6. Secure enclosure to upper support bracket with two screws (2) . Tighten.  
Torque: 48-60 in-lbs (5.4-6.8 N-m) Upper support bracket to speaker enclosure screws
7. Mate speaker and power outlet connectors. Secure harness anchors to speaker enclosure.
8. Install CB module if equipped. See CB MODULE (Page 8-78).
9. Install outer fairing. See FAIRING: FORK MOUNTED (Page 3-89).

### Speaker Grille

1. Remove speaker enclosure. See Remove in this section.
2. See Figure 8-78. Remove three screws (4).
3. Remove speaker grille (5).
4. Install speaker grille and secure with screws (4).  
Tighten.  
Torque: 9-13 in-lbs (1-1.5 N-m) Fairing speaker grille screws
5. Install speaker enclosure. See Install in this section.



sm07503



1. Enclosure-to-fairing support screw (3)
2. Upper bracket-to-enclosure screw (2)
3. Speaker enclosure
4. Speaker grill screw (3)
5. Speaker grill
6. Fairing support
7. Speaker connector
8. Enclosure-to-fairing screw (3)

Figure 8-78. Speaker Enclosure

## REMOVE AND INSTALL: FRAME MOUNTED FAIRING

### NOTE

| FASTENER                                       | TORQUE VALUE |             |
|--|--------------|-------------|
| Speaker enclosure mounting screws, front, FLTR | 48-60 in-lbs | 5.4-6.8 N-m |
| Speaker mounting screws                        | 9-13 in-lbs  | 1-1.5 N-m   |

Repair of the left and right sides are similar.

Speaker enclosure removal and installation does not require speaker removal.

### Speaker Grille

1. **NOTE**  
Do not damage speaker when inserting right angle tool.

See Figure 8-79. Remove speaker grille. Method A:

- a. Carefully insert a right angle tool (3) through a hole in the grille next to one retainer (1).
- b. Pull to release retainer.
- c. Repeat with remaining retainer.
- d. Remove speaker grille.

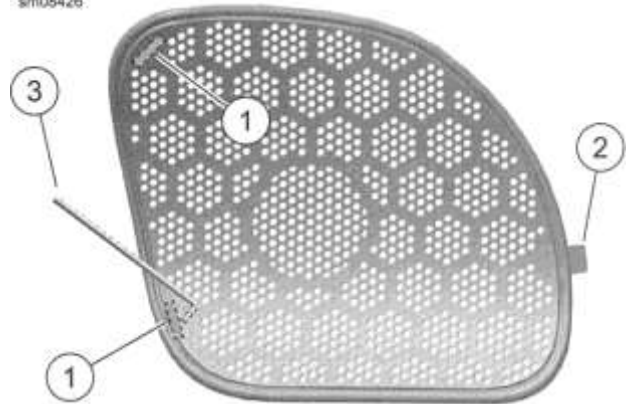
#### 2. Method B:

- a. Remove top air duct.
- b. From above, reach down into speaker area. Push on tab to disengage upper retainer (1).
- c. Carefully pull near lower retainer (1) to disengage. Remove grille.

#### 3. See Figure 8-80. Install speaker grille:

- a. Verify that rubber gasket is in place on perimeter of grille.
- b. Engage tab (2) into grille opening.
- c. Engage retainers (1) in slots.
- d. Push on grille in retainer areas until an audible click is

sm08426



1. Retainer (2)
2. Tab
3. Right angle tool

heard.

Figure 8-79. Remove Speaker Grille

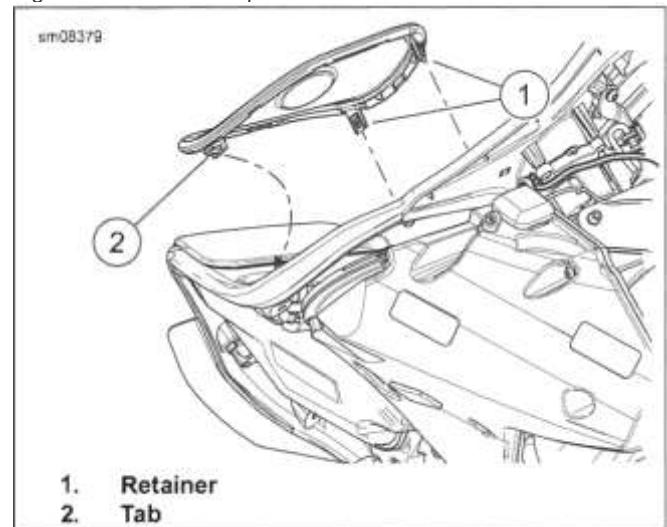


Figure 8-80. Speaker Grille

### Speaker

1. Remove speaker grille.
2. Remove screws securing speaker to enclosure.
3. Hold speaker away from enclosure and disconnect wires. Remove speaker.

4. **NOTE**

*Verify hole in speaker frame mates with alignment pin on enclosure.*  
**FRONT SPEAKERS**

**8.33**

Connect wires to speaker terminals. Set speaker in place.

## REAR SPEAKERS

5. Secure with four screws. Tighten.

Torque: 9-13 in-lbs (1-1.5 N-m) *Speaker mounting screws*

6. Install speaker grille.
2. Attach speaker wire connectors.

### Speaker Enclosure

#### NOTE

Never operate vehicle with the speaker enclosures removed. These components provide important structural support to the inner fairing. Operating without these components can result in damage to fairing assembly.

#### Remove

1. Remove outer fairing. See FAIRING: FRAME MOUNTED (Page 3-100).
4. Secure with four screws. Tighten.
2. See Figure 8-81. Disconnect speaker connector (2).
3. Left side: Remove power port cable from features on enclosure.
4. Right side: Separate USB cable anchor (6) from tab (5) at upper corner of enclosure.

5. **NOTE**

Do not remove the Torx head screws securing the speaker enclosure halves together.

Remove three socket head screws (3) securing lower enclosure.

6. Remove two socket head screws (1) securing enclosure to support bracket.
7. Remove speaker enclosure (4) from fairing.
8. Remove four screws to free speaker from enclosure.
9. Disconnect wires. Remove speaker from enclosure.
10. If necessary, remove grommet and harness.

#### Install

#### NOTE

Verify that the harness grommet is correctly installed. An incorrectly installed grommet can result in poor audio, whistling or

1. If removed, install harness and grommet.
3. Install left saddlebag. See SADDLEBAGS (Page 3-161).

3. Align hole in speaker frame with alignment pin on enclosure and install speaker.

Torque: 9-13 in-lbs (1-1.5 N-m) *Speaker mounting screws*

5. See Figure 8-81. Install speaker enclosure (4) to inner fairing. Start all screws (1, 3).
6. Tighten both upper screws (1) then lower screws (3) from front to rear.

Torque: 48-60 in-lbs (5.4-6.8 N-m) *Speaker enclosure mounting screws, front, FLTR*

7. Secure harness to speaker enclosure.

a rattle.

8. Install outer fairing. See FAIRING: FRAME MOUNTED (Page 3-100).

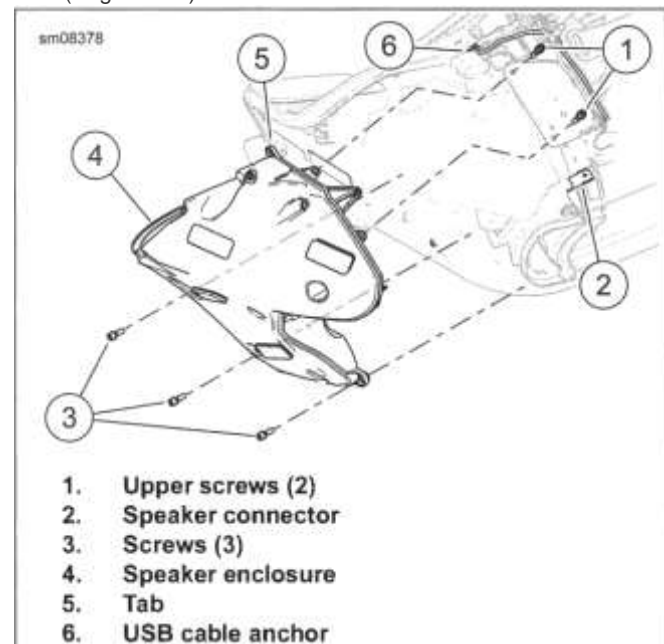


Figure 8-81. Speaker Enclosure (right side shown)

#### COMPLETE

1. Install main fuse. See POWER DISCONNECT (Page 8-8).
2. Install left side cover. See LEFT SIDE COVER (Page 3-62).

## PREPARE

1. Remove left saddlebag. See SADDLEBAGS (Page 3-161).
2. Remove left side cover. See LEFT SIDE COVER (Page 3-62).
3. Remove main fuse. See POWER DISCONNECT (Page 8-8).

## REMOVE

### Speaker Only

1. See Figure 8-84. Remove screws (4).
2. Remove speaker (3) and grille (5) from enclosure.
3. Disconnect terminals.

### Speaker and Enclosure

#### NOTE

*It is not necessary to remove the enclosure to service internal components.*

1. Remove Tour-Pak liner. See TOUR-PAK (Page 3-153).
2. See Figure 8-82. Separate speaker pod jumper (2) connector from main harness.

#### 3. NOTE

*If both speaker enclosures are removed, connector disassembly is not required.*

Remove appropriate terminals from housing. See the electrical diagnostics manual.

4. See Figure 8-83. Remove screws (6) with flat washers (5) to free speaker enclosure (and power outlet (4) right side only) from Tour-Pak.
5. Remove gasket (2) and sound port (3).

## INSTALL

| FASTENER                                  | TORQUE VALUE |             |
|---|--------------|-------------|
| Rear speaker enclosure to Tour-Pak screws | 20-25 in-lbs | 2.3-2.8 N-m |

### Speaker Only

1. Connect terminals.
2. See Figure 8-84. Install speaker (3) and grille (5) to enclosure.
3. Install screws (4). Tighten carefully.

### Speaker and Enclosure

1. See Figure 8-83. Install sound port (3) and new gasket (2).
2. Install three screws (6) with flat washers (5) to secure speaker enclosure (1), sound port (3) and power outlet (4) (right side only) to Tour-Pak. Tighten.  
  
Torque: 20-25 in-lbs (2.3-2.8 N-m) *Rear speaker enclosure to Tour-Pak screws*
3. If necessary, install terminals in connector housing. See the electrical diagnostics manual.
4. Mate rear audio connector to main harness.
5. Install Tour-Pak liner. See TOUR-PAK (Page 3-153).

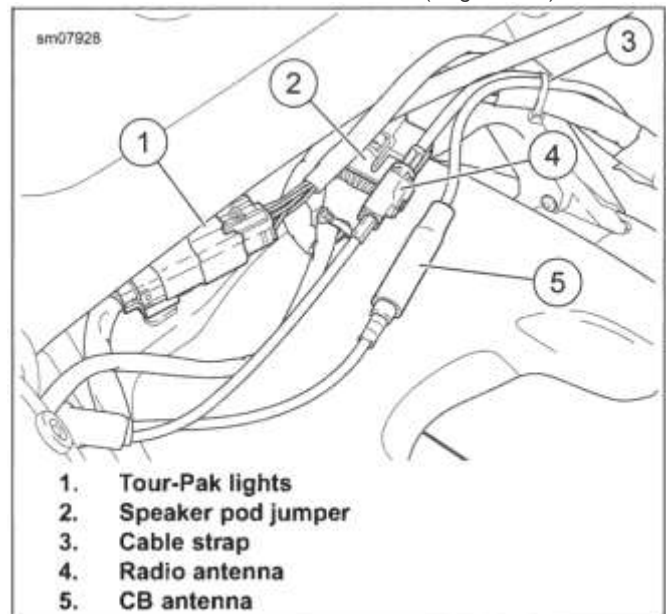


Figure 8-82. Tour-Pak Harness Connectors

**REAR SPEAKERS**

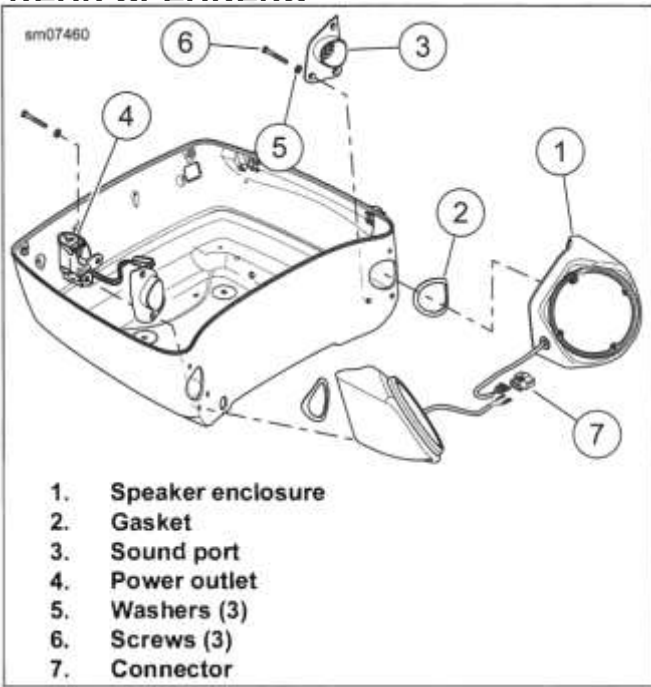


Figure 8-83. Speaker Enclosures

- c. Remove harness and switch assembly.
- d. Remove switch bezel (8).
- 4. Left speaker:
  - a. Using DIN connector tool, remove nut and weather cap from passenger headset connector.  
Special Tool: DIN CONNECTOR TOOL (HD-51656)
  - b. Remove passenger headset connector and harness assembly.
- 5. See Figure 8-83. To separate left and right harnesses, remove terminals from connector (7).
- 6. Remove harness grommet.

**ASSEMBLE**

| PART NUMBER | TOOL NAME          |
|-------------|--------------------|
| HD-51656    | DIN CONNECTOR TOOL |

| FASTENER                        | TORQUE VALUE |             |
|---------------------------------|--------------|-------------|
| Passenger audio switch screws   | 25-30 in-lbs | 2.8-3.4 N-m |
| Passenger headset connector nut | 7-9 in-lbs   | 0.8-1 N-m   |

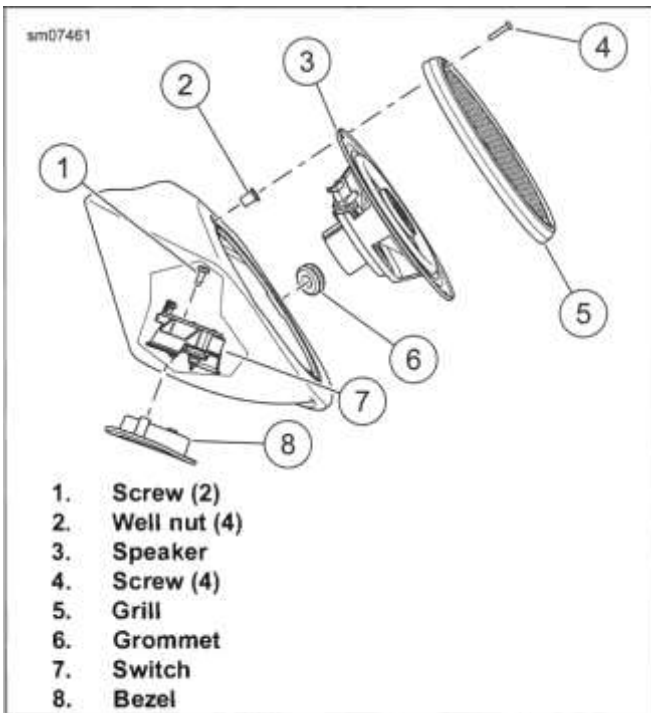


Figure 8-84. Rear Speaker (typical)

- 1. Install harness grommet. The left enclosure grommet has the larger hole.
- 2. See Figure 8-82. If separated, assemble left and right harnesses to connector (7). See the electrical diagnostics manual.
- 3. See Figure 8-84. Right speaker:
  - a. Install switch bezel (8).
  - b. Install harness and switch (7) assembly with wires nearest to wall of speaker enclosure.
  - c. Install screws (1) securing switch. Tighten.  
Torque: 25-30 in-lbs (2.8-3.4N-m) *Passenger audio switch screws*
  - d. Install well nut (2) removed to access screw.
  - e. Route harness through grommet (6).
- 4. Left speaker:
  - a. Install passenger headset connector and harness assembly.
  - b. Install weather cap and nut to secure passenger headset connector. Using DIN connector tool, tighten.  
Torque: 7-9 in-lbs (0.8-1 N-m) *Passenger headset connector nut*  
Special Tool: DIN CONNECTOR TOOL (HD-51656)
  - c. Route harness under boss and through grommet.

**DISASSEMBLE**

| PART NUMBER | TOOL NAME          |
|-------------|--------------------|
| HD-51656    | DIN CONNECTOR TOOL |

- 1. See Figure 8-84. Remove four screws (4).
- 2. Remove speaker (3) and grille (5) from enclosure. Disconnect terminals.
- 3. Right speaker:
  - a. Remove well nut (2) to access switch screw (1).
  - b. Remove screws securing switch (7).

5. Install cable strap on harness next to inside of grommet (6) to act as strain relief.

6. Connect terminals to speaker.

7. *NOTE*

*Over-tightening screws (4) can cause well nuts to pull through mounting holes.*

Secure speaker and grille with four screws (4). Tighten carefully.

**COMPLETE**

1. Install main fuse. See POWER DISCONNECT (Page 8-8).

2. Install left side cover. See LEFT SIDE COVER (Page 3-62).

3. Install left saddlebag. See SADDLEBAGS (Page 3-161).

----- Perform disassembly and assembly procedures for rear speaker enclosure. See REAR SPEAKERS (Page 8-73).

*NOTE*

*It is not necessary to remove the enclosure to service the rear speaker components.*

## PREPARE

1. Remove left saddlebag. See SADDLEBAGS (Page 3-161).
2. Remove left side cover. See LEFT SIDE COVER (Page 3-62).
3. Remove main fuse. See POWER DISCONNECT (Page 8-8).
4. Remove console. See CONSOLE (Page 6-5).

## REMOVE

1. Using DIN connector tool, rotate lock ring counterclockwise

| PART NUMBER | TOOL NAME          |
|-------------|--------------------|
| HD-51656    | DIN CONNECTOR TOOL |

to loosen.

Special Tool: DIN CONNECTOR TOOL (HD-51656)

2. Remove lock ring and cap.
3. Remove headset connector and harness assembly.

## INSTALL

| PART NUMBER | TOOL NAME          |
|-------------|--------------------|
| HD-51656    | DIN CONNECTOR TOOL |

| FASTENER                    | TORQUE VALUE |           |
|-----------------------------|--------------|-----------|
| Rider headset connector nut | 7-9 in-lbs   | 0.8-1 N-m |

1. Insert headset connector through hole in console.
2. Slide weather cap over headset connector.
3. With notches outboard, thread lock ring onto headset connector.
4. Using DIN connector tool, tighten.

Torque: 7-9 in-lbs (0.8-1 N-m) *Rider headset connector nut*  
 Special Tool: DIN CONNECTOR TOOL (HD-51656)

## COMPLETE

1. Install console on fuel tank capturing wire harness and front headset connector harnesses in metal clips. See CONSOLE (Page 6-5).
2. Install main fuse. See POWER DISCONNECT (Page 8-8).
3. Test operation of headset connector.
4. Install left side cover. See LEFT SIDE COVER (Page 3-62).
5. Install left saddlebag. See SADDLEBAGS (Page 3-161).



**PREPARE**

1. Remove left saddlebag. See SADDLEBAGS (Page 3-161).
2. Remove left side cover. See LEFT SIDE COVER (Page 3-62).
3. Remove main fuse. See POWER DISCONNECT (Page 8-8).
4. Remove outer fairing. See FAIRING: FORK MOUNTED (Page 3-89).

**REMOVE**

**CB Module**

1. See Figure 8-85. Disconnect:
  - a. CB antenna cable connector (2).
  - b. CB module connector (1).
2. Remove screw (3).
3. Remove CB module.

**CB Module Bracket**

1. Remove upper fairing support. See FAIRING: FORK MOUNTED (Page 3-89).
2. Remove screw securing bracket to speaker enclosure.

**INSTALL**

| FASTENER                                     | TORQUE VALUE |       |
|--|--------------|-------|
|  | in-lbs       | N-m   |
| CB module bracket to speaker enclosure screw | 25-35        | 2.8-4 |

**CB Module Bracket**

1. Install bracket to speaker enclosure screw. Tighten.  
Torque: 25-35 in-lbs (2.8-4 N-m) *CB module bracket to speaker enclosure screw*
2. Install upper fairing support. See FAIRING: FORK MOUNTED (Page 3-89).

**CB Module**

1. Slide CB module into place. Verify the alignment pins engage the holes in the enclosure.
2. Install screw (3). Tighten.
3. See Figure 8-85. Mate connectors:
  - a. CB antenna cable connector (2).
  - b. CB module connector (1).

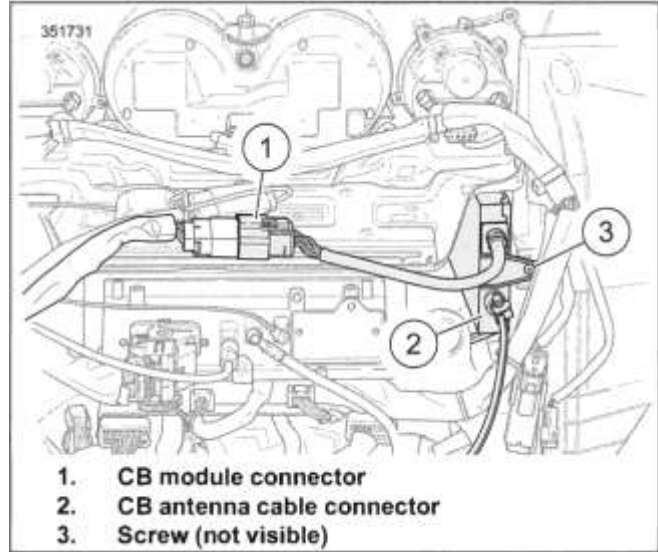


Figure 8-85. CB Connectors

**COMPLETE**

1. Install main fuse. See POWER DISCONNECT (Page 8-8).
2. Test CB function.
3. Install outer fairing. See FAIRING: FORK MOUNTED (Page 3-89).
4. Install left side cover. See LEFT SIDE COVER (Page 3-62).
5. Install left saddlebag. See SADDLEBAGS (Page 3-161).

**PREPARE**

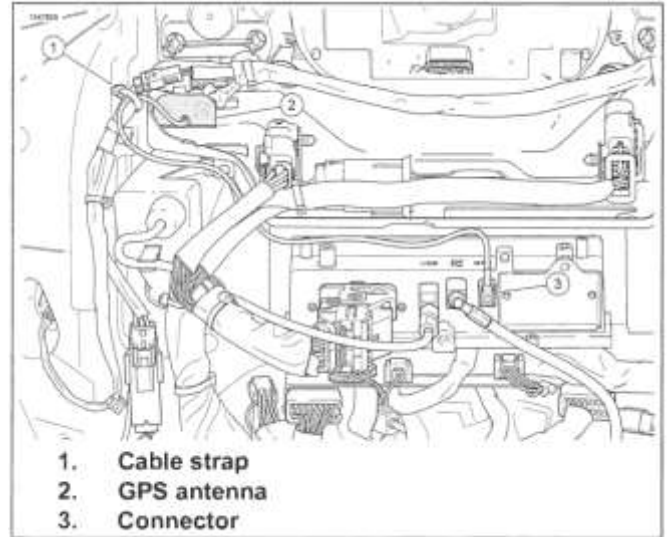
Install antenna connector (3) to the radio.

1. Remove left saddlebag. See SADDLEBAGS (Page 3-161).
2. Remove left side cover. See LEFT SIDE COVER (Page 3-62).
3. Remove main fuse. See POWER DISCONNECT (Page 8-8).
4. Remove outer fairing. See FAIRING: FORK MOUNTED (Page 3-89).

3. Secure antenna lead to harness with cable strap (1).

**REMOVE**

1. See Figure 8-86. Cut cable strap (1).
2. Disconnect antenna connector (3).
3. Gently pry the antenna (2) from the upper support bracket.



**Figure 8-86. GPS Antenna**

**INSTALL**

1. See Figure 8-86. Install antenna:
  - a. Clean the top of the upper support bracket with isopropyl alcohol. Allow to dry completely.
  - b. Remove adhesive backing from the antenna.
  - c. With the wire lead toward the right, press and hold antenna (2) for 60 seconds.

2. **NOTE**  
 After installing the antenna, avoid contact with or movement of the antenna for 20 minutes.

**COMPLETE**

1. Install main fuse. See POWER DISCONNECT (Page 8-8).
2. Test GPS.
3. Install outer fairing. See FAIRING: FORK MOUNTED (Page 3-89).
4. Install left side cover. See LEFT SIDE COVER (Page 3-62).
5. Install left saddlebag. See SADDLEBAGS (Page 3-161).

**PREPARE**

1. Remove left saddlebag. See SADDLEBAGS (Page 3-161).
2. Remove left side cover. See LEFT SIDE COVER (Page 3-62).
3. Remove main fuse. See POWER DISCONNECT (Page 8-8).

**REMOVE AND INSTALL: MAIN CABLE** \_\_\_\_\_

*NOTE*

- Replacement of the radio and CB antenna cables is basically the same.
- Most of the original cable remains within the main harness conduit.

**Remove**

1. Remove seat. See SEAT (Page 3-148).
2. Remove fuel tank. See FUEL TANK (Page 6-10).
3. Remove outer fairing. See FAIRING: FORK MOUNTED (Page 3-89) or FAIRING: FRAME MOUNTED (Page 3-100).
4. See Figure 8-87. Disconnect antenna cable (1) from radio. Cut cable where it exits front and rear of the main harness.
5. Remove wire trough cover.
6. See Figure 8-88. Disconnect antenna cable connector (4) at rear fender.
7. Cut cable strap (3). Remove antenna cable.

**Install**

1. See Figure 8-87. Connect new radio antenna cable connector to radio.
2. Route free end of radio antenna cable rearward along left side of steering head and through left side of wire trough. Continue along inboard side of left upper frame tube to top of rear fender.
3. See Figure 8-88. Mate antenna cable connectors at top of rear fender. Install new cable strap (3).
4. Capture antenna cable and main harness in steering head retainer.
5. Install two new cable straps to secure antenna cable and main harness to left upper frame tube.
6. Install wire trough cover. Verify that all latches are fully engaged.
7. Install fuel tank. See FUEL TANK (Page 6-10).
8. Install seat. See SEAT (Page 3-148).

9. Install outer fairing. See FAIRING: FORK MOUNTED (Page 3-89) or FAIRING: FRAME MOUNTED (Page 3-100).

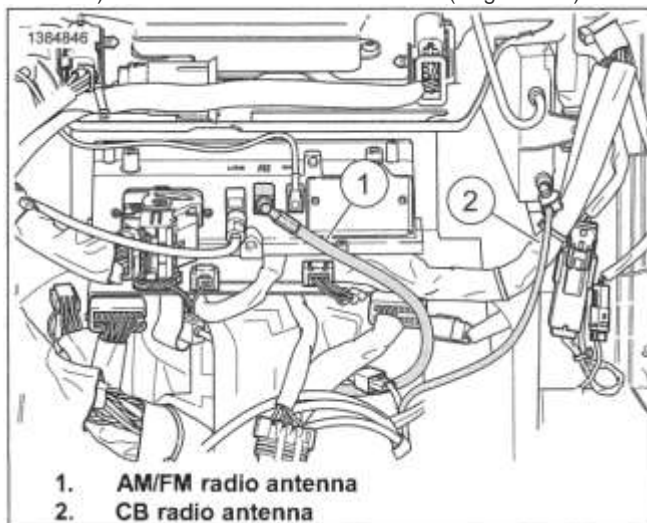


Figure 8-87. Radio Antenna Cable Connectors

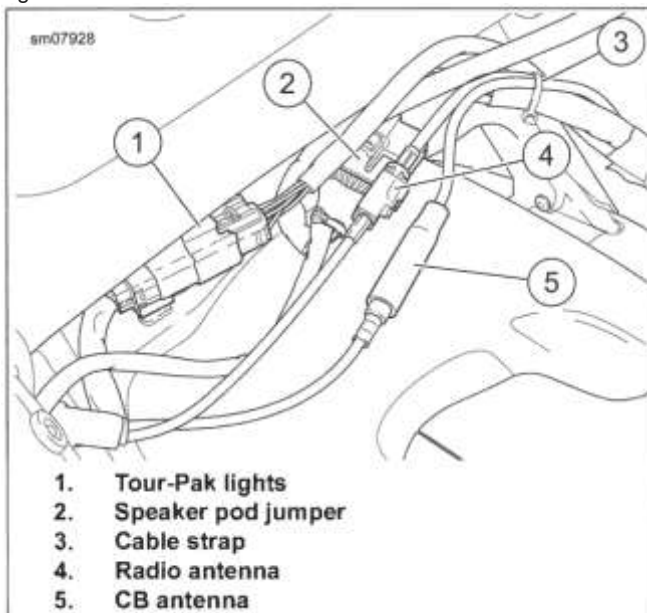


Figure 8-88. Tour-Pak Harness Connectors

**REMOVE AND INSTALL: CABLE EXTENSION (MODELS WITH TOUR-PAK)**

**Remove**

1. Remove Tour-Pak harness. See TOUR-PAK WIRE HARNESS (Page 8-114).
2. See Figure 8-89. Cut cable strap (2). Peel away the forward wrap (3).
3. CB antenna cable (6):
  - a. Remove tape (5) securing cable to harness.

- b. Remove antenna cable.

**4. Radio antenna cable (7):**

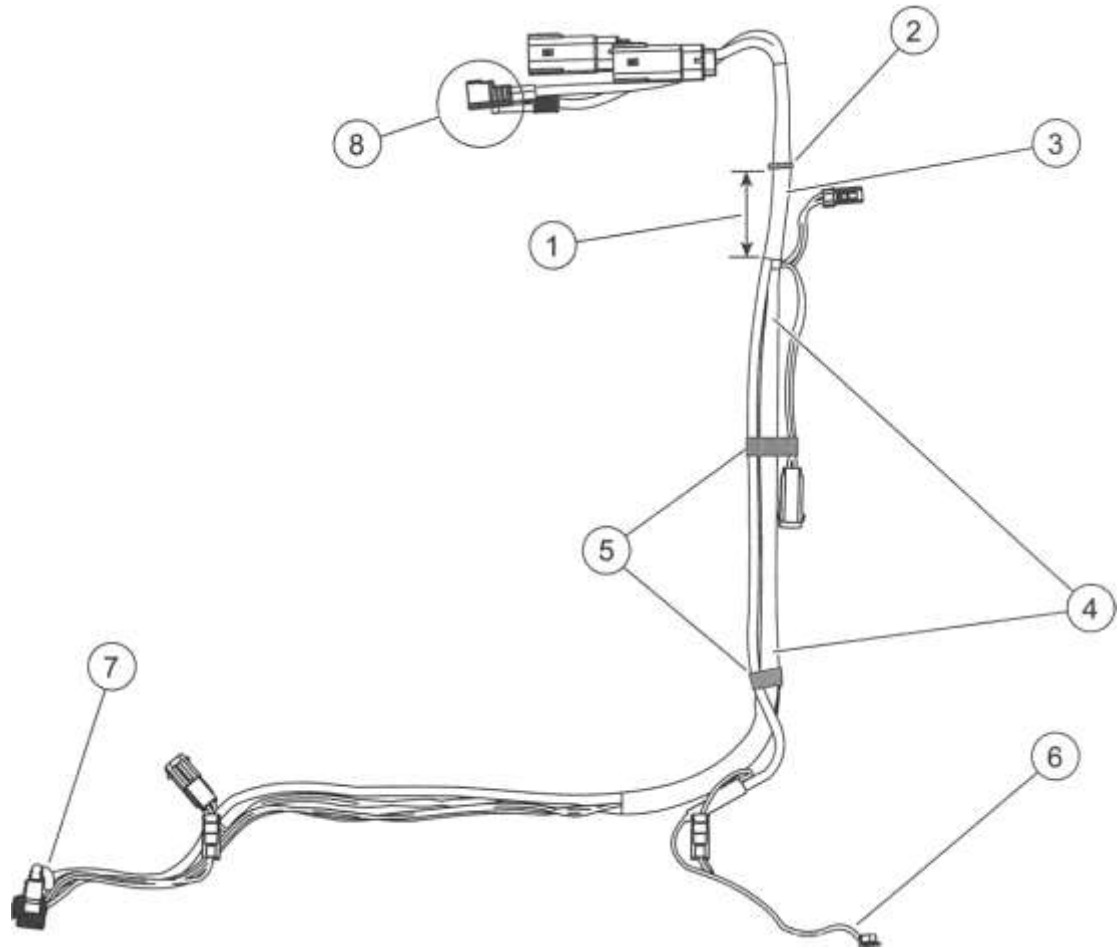
- a. Cut antenna cable extension where it exits each end of harness wrap.
- b. Remove antenna cable.

- 2. Secure cable to harness with tape (5).
- 3. Install **new** forward wrap (3) next to rear wrap (4) remaining on harness.
- 4. Install **new** cable strap (2) dimension (1) from end of forward wrap.  
2 in (51 mm)
- 5. Install Tour-Pak harness. See TOUR-PAK WIRE HARNESS (Page 8-114).

**Install**

- 1. See Figure 8-89. Lay **new** antenna cable along harness with front connector even with other antenna cable connector (8).

sm07938



- |                             |                        |
|-----------------------------|------------------------|
| 1. Dimension to cable strap | 5. Electrical tape     |
| 2. Cable strap              | 6. CB antenna cable    |
| 3. Forward wrap             | 7. Radio antenna cable |
| 4. Rear wrap                | 8. Antenna cable ends  |

**Figure 8-89. Antenna Leads**

**REMOVE AND INSTALL: CABLE EXTENSION (MODELS WITHOUT TOUR-PAK)**

**Remove**

- 1. See Figure 8-90. Release antenna cable from three upper clips (1).
- 2. Disconnect antenna cable from antenna.

- 3. See Figure 8-91. Disconnect antenna cable connector (1). Remove cable.

**Install**

- 1. See Figure 8-91. Route antenna cable back along upper left frame, under frame cross member and through opening in left caddy. Continue along saddlebag support to antenna.
- 2. Figure 8-90. Pass connector through grommet and connect to bottom of antenna.

3. Capture cable in three upper clips (1).

4. Mate to connector (1).

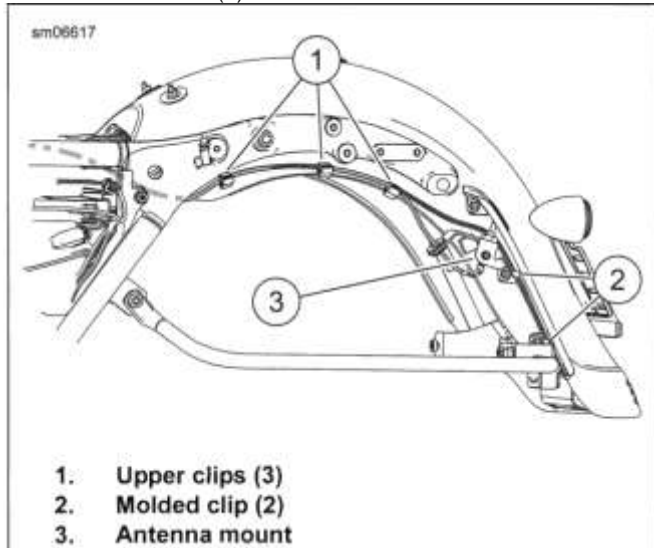


Figure 8-90. Rear Fender Lamps Harness and Antenna Cable: FLHX, FLHXS, FLTRX, FLTRXS

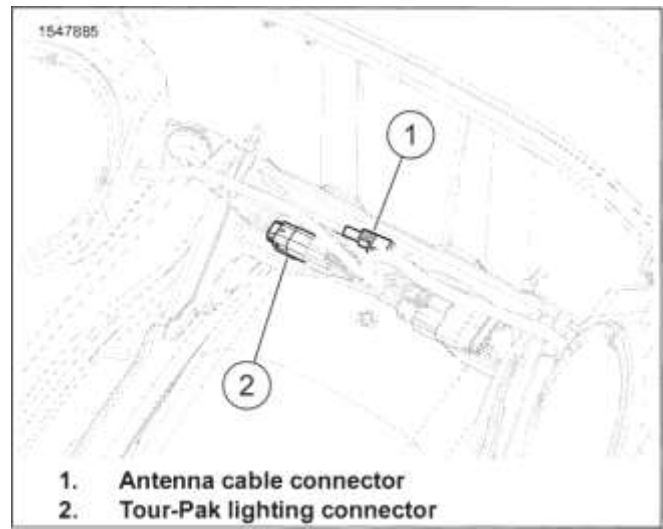


Figure 8-91. Rear Fender Lamps Harness and Antenna Cable Routing: FLHX, FLHXS, FLTRX, FLTRXS

**COMPLETE**

1. Install main fuse. See POWER DISCONNECT (Page 8-8).
2. Install left side cover. See LEFT SIDE COVER (Page 3-62).
3. Install left saddlebag. See SADDLEBAGS (Page 3-161).

**PREPARE**

b. Follow on-screen prompts.

1. Remove seat. See SEAT (Page 3-148).
2. Detach security system antenna from top caddy. See SECURITY SYSTEM ANTENNA (Page 8-90).

**REMOVE**

1. See Figure 8-92. Push latches (2) to free ECM (3) from top caddy.
2. Disconnect ECM connector (1). See the electrical diagnostic manual.

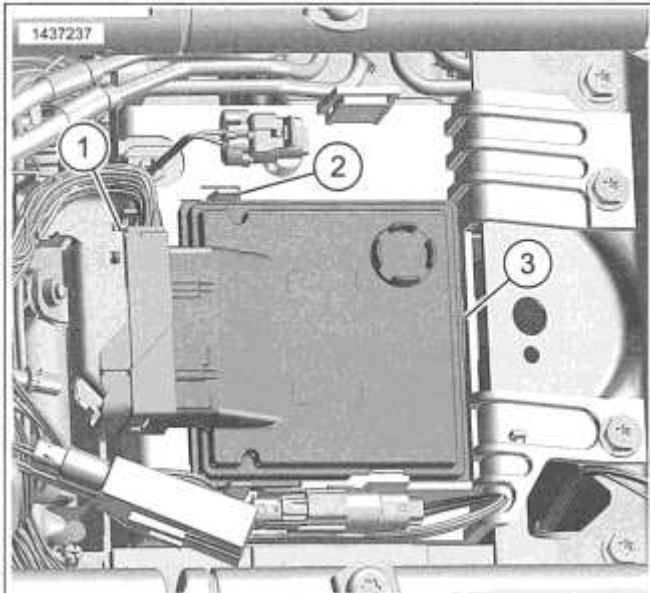
| PART NUMBER | TOOL NAME             |
|-------------|-----------------------|
| HD-48650    | DIGITAL TECHNICIAN II |

**INSTALL***NOTE*

- Whenever a **new** TGS or ECM is installed, perform idle speed procedure. Failure to perform these steps can result in initial performance problems.
- After installing **new** ECM, always perform password learn procedure using Digital Technician II. See the electrical diagnostic manual.

1. Connect ECM connector (1).
2. Secure ECM in top caddy.
3. If installing a new ECM, it must be set up using DT-I1.  
Special Tool: DIGITAL TECHNICIAN II (HD-48650)
  - a. Choose REFLASH icon.

4. If a new ECM was installed, reset idle speed.
  - a. Place engine run/stop switch in RUN position.
  - b. Turn ignition switch to IGNITION then OFF four times without starting engine. Wait at least three seconds between ignition cycles.



1. Connector
2. Latch (2)
3. ECM

Figure 8-92. ECM

## **COMPLETE**

1. Attach security system antenna to top caddy. See SECURITY SYSTEM ANTENNA (Page 8-90).
2. Install seat. See SEAT (Page 3-148).

**PREPARE**

1. Remove left saddlebag. See SADDLEBAGS (Page 3-161).
2. Remove left side cover. See LEFT SIDE COVER (Page 3-62).
3. **Siren equipped models:** With security fob present, turn ignition switch ON.
4. Remove main fuse. See POWER DISCONNECT (Page 8-8).

**REMOVE**

1. See Figure 8-93. Lift retaining tab and pull BCM (3) from left caddy.
2. Remove BCM power wire connector (4).
3. Unlock latch and rotate lock (2) until a click is heard. Remove BCM connector (1).

**INSTALL**

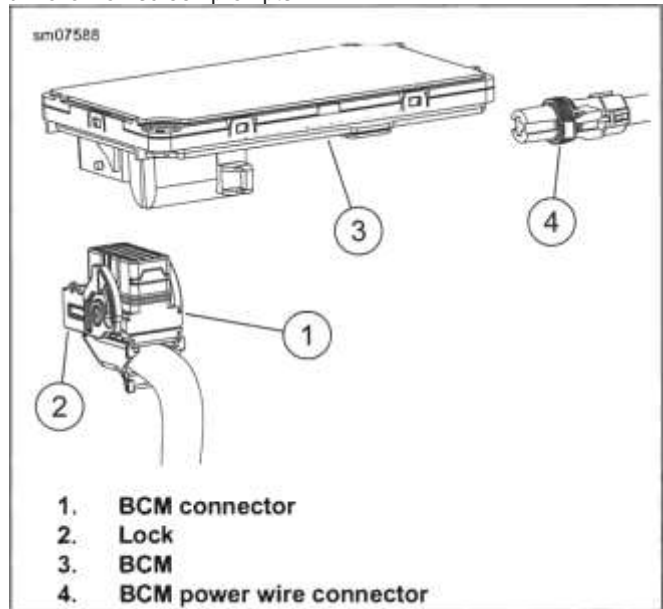
1. See Figure 8-93. Install BCM connector (1). Rotate lock (2)

| PART NUMBER | TOOL NAME             |
|-------------|-----------------------|
| HD-48650    | DIGITAL TECHNICIAN II |

to secure.

2. Connect BCM power wire (4).
3. Install BCM in left caddy.

4. If installing a **new** BCM, it must be set up using DT-I1.
  - Special Tool: DIGITAL TECHNICIAN II (HD-48650)
    - a. Choose VEHICLE SETUP icon.
    - b. Follow on-screen prompts.



**Figure 8-93. BCM**

**COMPLETE**

1. Install main fuse. See POWER DISCONNECT (Page 8-8).
2. Install left side cover. See LEFT SIDE COVER (Page 3-62).
3. Install left saddlebag. See SADDLEBAGS (Page 3-161).



## ACTIVATION

Activation consists of assigning two fobs to the system and entering an initial PIN.

**NOTE**

*If the fob is lost or inoperable, the PIN allows the owner to disarm the system. See PERSONAL IDENTIFICATION NUMBER (PIN) (Page 8-86).*

1. Configure the security system by assigning both fobs to the vehicle.
2. Configure the security system by entering a PIN picked by the owner.

Record the PIN in the owner's manual. Instruct the customer to carry a copy (use the wallet card found in the owner's manual). See PERSONAL IDENTIFICATION NUMBER (PIN) (Page 8-86).

Once the system has been activated, it "arms" within 5 seconds of switching the IGN switch to OFF and no motorcycle motion.

## **FOB ASSIGNMENT** \_\_\_\_\_

| PART NUMBER | TOOL NAME             |
|-------------|-----------------------|
| HD-48650    | DIGITAL TECHNICIAN II |

Use DIGITAL TECHNICIAN II (PART NUMBER: HD-48650) to assign both fobs to the vehicle.

**NOTE**

- Choose the correct fob type. Choosing incorrectly at the beginning of the process will result in a failure to assign the fob. This can be mistakenly diagnosed as a bad fob or SCM.

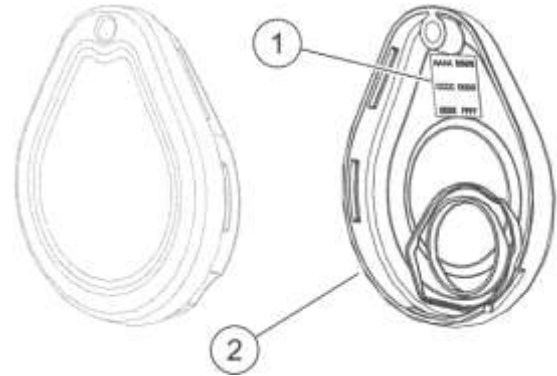
- When assigning a fob, keep the fob within 3 ft (1 m) of the vehicle seat.

See Figure 8-94. Follow the menu prompts to scan the fob serial number with the bar code reader. Alternatively, enter the number using the keyboard. Use DIGITAL TECHNICIAN II (PART NUMBER: HD-48650) to assign fob and enter initial PIN.

**NOTE**

*Each fob has a unique serial number. Attach fob label to a blank NOTES page in the owner's manual for reference.*

sm08666



**Figure 8-94. Fob Serial Number**

1. Fob serial number
2. Fob cover

**GENERAL**

The PIN consists of five digits. Each digit can be any number from 1 through 9. There can be no zeros (0) in the PIN. Use the PIN to disarm the security system in case the fob becomes unavailable.

**CHANGING THE PIN**

The rider can change the PIN at any time. Refer to Table 8-7.

**Modifying an Existing PIN**

If a PIN was previously entered, the odometer will display the equivalent digit. Each additional press of the left turn switch will increment the digit.

Examples:

- To advance from 5 to 6, press and release the left turn switch 1 time.
- To advance from 8 to 2, press and release the left turn switch 3 times (9-1-2).

**Table 8-7. Changing the PIN**

| STEP NO. | ACTION  | WAIT FOR CONFIRMATION   | NOTES  |
|----------|---|---|--|
| 1        | Select a 5-digit (1 thru 9) PIN and record on the wallet card from owner's manual.  |   |  |
| 2        | With an assigned fob present, turn the OFF/RUN switch to <b>OFF</b> .   |   |  |
| 3        | Turn the OFF/RUN switch to <b>RUN</b> .   |   |  |
| 4        | Cycle the OFF/RUN switch twice: <b>RUN -OFF • RUN • OFF • RUN</b> .   |   |  |
| 5        | Press <b>left</b> turn signal switch <b>two times</b> .   | ENTER PIN will scroll through the odometer window.  |  |
| 6        | Press <b>right</b> turn signal switch <b>one time</b> and release.  | Turn signals will flash three times. Current PIN will appear in odometer. The first digit will be flashing. |  |
| 7        | Enter first digit of new PIN by pressing and releasing the <b>left</b> turn signal switch until the selected digit appears.             |   |  |
| 8        | Press <b>right</b> turn signal switch <b>one time</b> and release.  | The new digit will replace the current in odometer window.  |  |
| 9        | Enter second digit of selected PIN by pressing and releasing the <b>left</b> turn signal switch until the selected digit is present.    |   |  |
| 10       | Press <b>right</b> turn signal switch <b>one time</b> and release.  | The new digit will replace the current in odometer window.  |  |
| 11       | Enter third digit of the selected PIN by pressing and releasing the <b>left</b> turn signal switch until the selected digit is present. |   |  |
| 12       | Press <b>right</b> turn switch <b>one time</b> and release.   | The new digit will replace the current in odometer window.  |  |
| 13       | Enter fourth digit of new PIN by pressing and releasing the <b>left</b> turn signal switch until the selected digit is present.         |   |  |
| 14       | Press <b>right</b> turn switch <b>one time</b> and release.   | The new digit will replace the current in odometer window.  |  |
| 15       | Enter fifth digit of the new PIN by pressing and releasing the <b>left</b> turn signal switch until the selected digit is present.      |   |  |
| 16       | Press <b>right</b> turn switch <b>one time</b> and release.   | The new digit will replace the current in odometer window.  |  |
| 17       | Turn the OFF/RUN switch <b>OFF</b> , then turn the ignition switch to <b>OFF</b> .  |   | Pushing the OFF/RUN switch to <b>OFF</b> stores the new PIN in the module. |

## SERVICE MODE

| PART NUMBER | TOOL NAME             |
|-------------|-----------------------|
| HD-48650    | DIGITAL TECHNICIAN II |

With a fob present, the security system can be configured for service by disabling the security system with DIGITAL TECHNICIAN II (PART NUMBER: HD-48650).

Once disabled, the vehicle can be operated without an assigned fob present. To maintain the service mode, the assigned fobs must be kept out of range. If the fob appears in range, the service mode is cancelled.

## TRANSPORT MODE

It is possible to arm the security system without enabling the motion detector for one ignition cycle. The motorcycle can be moved in an armed state. The motorcycle cannot be turned on or started while in transport mode until the fob is present.

### To Enter Transport Mode

1. With security fob present, set the OFF/RUN switch to RUN.
2. Set the OFF/RUN switch to OFF.
3. Simultaneously press both the left and the right turn signal switches within five seconds of turning the OFF/RUN switch to OFF.
4. Following a single flash, the turn signals flash three times to indicate that the system is armed in transport mode.

### To Exit Transport Mode

With the fob present, set the OFF/RUN switch to RUN to disarm the system and exit transport mode.

## FOB BATTERY

### Battery Replacement Schedule

Replace the fob battery every year.

### Battery Replacement

1. Open the fob case.
  - a. See Figure 8-95. Place a thin blade in the thumbnail slot(1).
  - b. Twist the blade to separate cases.

**NOTE**

Use a CR2032 or equivalent battery.

2. Install a new battery with the positive side up.
  - a. Push the latch (3) away from the battery.
  - b. Lift the battery from the side opposite the latch.
  - c. Verify that the metal tabs will firmly contact battery. Bend up slightly if necessary.
  - d. Install the battery against the latch with the positive side up. Drop into place.

3. Close the case.
  - a. Align case halves.
  - b. Snap case halves together.

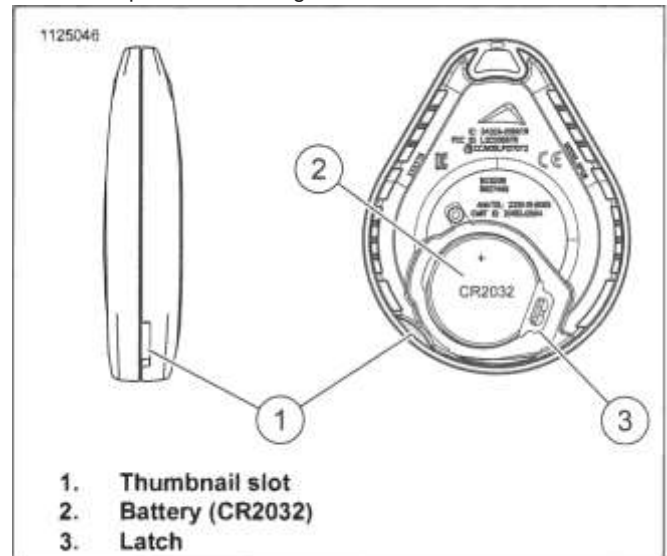


Figure 8-95. Replace Fob Battery

## SECURITY\_SIREN\_BATTERY

### Battery Replacement Schedule

The siren internal 9 V battery is rechargeable and does not require regular replacement. Battery life under normal conditions is approximately 3-6 years.

**NOTE**

If the motorcycle battery, is less than 12.5 v; the internal siren battery may not charge.

### Battery Replacement

1. Disarm system. Remove siren.
2. See Figure 8-96. With a small screwdriver, push the catches (1) in through the two slots (2) in the end of the siren. Release the battery cover (3).

**NOTE**

- For protection against corrosion, battery, terminals and battery, clip are covered with a special grease. Do not wipe away this substance. Apply all available existing grease to terminals on **new** battery.
  - Use only a 9 V nickel metal hydride battery, in the siren.
3. Replace 9 volt battery (4) by removing old battery from polarized battery clip.
  4. Recharge and install or install a **new** 9 volt nickel metal hydride battery.
  5. Install cover (3).
    - a. Carefully replace the rubber seal (5) on the cover.
    - b. Align battery cover with case placing round corners on cover away from connector [142A] (6).
    - c. Snap cover into place.

6. Install siren and check operation. Two chirps after an arming command indicate a working siren.

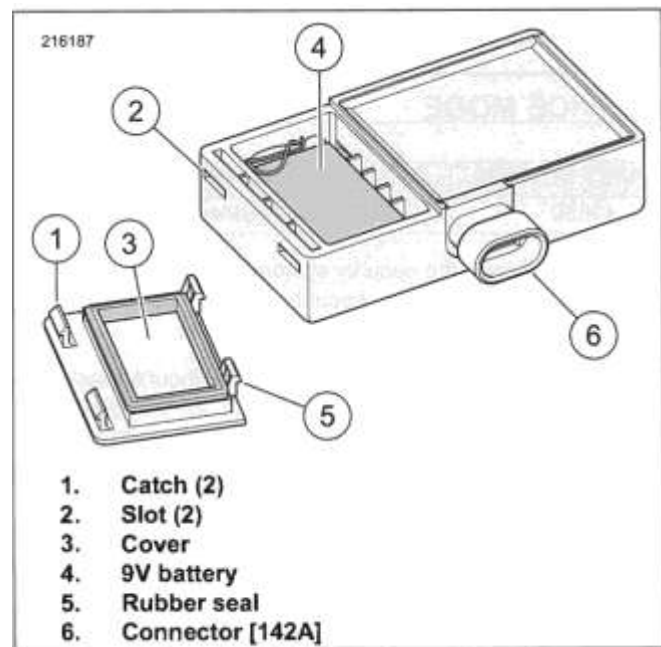


Figure 8-96. Battery Compartment

## PREPARE

1. Remove left side saddlebag. See SADDLEBAGS (Page 3-161).
2. Remove left side cover. See LEFT SIDE COVER (Page 3-62).
3. With security fob present, turn ignition switch ON.
4. Remove main fuse (3). See POWER DISCONNECT (Page 8-8).

## REMOVE

1. See Figure 8-97. Disconnect security siren connector (1).
2. Remove security siren (2).

## INSTALL

1. See Figure 8-97. Install security siren (2).
2. Connect security siren connector (1).

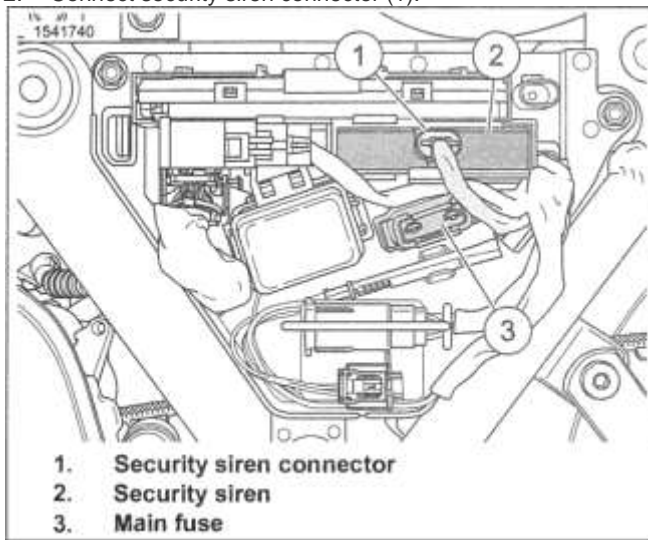


Figure 8-97. Security Siren

## COMPLETE

1. Install main fuse. See POWER DISCONNECT (Page 8-8).
2. Install left side cover. See LEFT SIDE COVER (Page 3-62).
3. Install left saddlebag. See SADDLEBAGS (Page 3-161).

## PREPARE

1. Remove seat. See SEAT (Page 3-148).

## REMOVE

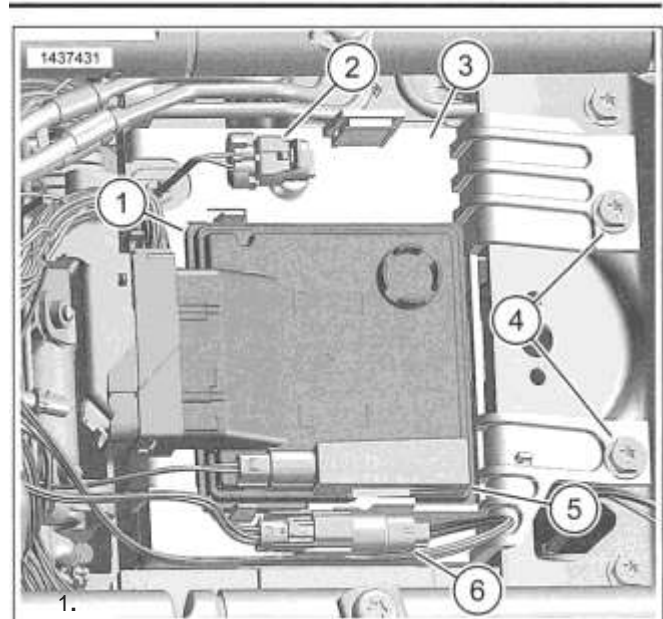
1. See Figure 8-98. Detach security system antenna (5) from top caddy (3).
2. Disconnect security system antenna.

## INSTALL

1. See Figure 8-98. Connect security system antenna (5) to harness.
2. Engage security system antenna groove on tongue at left side of top caddy (3).

### **ECM**

**Purge Solenoid Connector Top Caddy Screw (2)**



- 1.
- 2.
- 3.
- 4.
- 5.
- 6.

**Security system antenna**  
**Fuel pump connector**

**Figure 8-98. Top Caddy**

## COMPLETE

1. Test all security system functions.
2. Install seat. See SEAT (Page 3-148).

## PREPARE

### A CAUTION

Cooling fans operate automatically, even when the ignition switch is off. Keep hands away from fan blades. Contact with a rotating fan blade can result in minor or moderate injury. (00093a)

1. Remove main fuse. See POWER DISCONNECT (Page 8-8).
2. Remove access panel from fairing lower.
  - a. Pry the center top.
  - b. Pull out to release retainers.
3. Remove nut securing lower fairing cap.
4. Remove fairing cap.
5. See Figure 8-99. Remove lower fairing clamp screw and nut (8).
6. Remove nuts (7) securing upper clamp (5).
7. Move lower fairing away from engine guard to access screws (6).
8. Remove three screws (6) securing glove box frame (1).
9. Loosely install upper clamp.
10. Pull glove box frame away releasing two clips (14).
11. Disconnect vent linkage from vent door lever.
12. Right side: Remove nut (3) securing coolant bottle (4). Release bottle from stud and lower grommet.
13. Left side: Disconnect temperature sensor.

## REMOVE

1. See Figure 8-99. Remove screws (13).
2. Remove nut (2). Remove air duct (12).
3. Disconnect fan power connector (10). Remove connector anchor.
4. Pull radiator/fan assembly away from lower fairing.
5. Release latches securing fan to radiator. Remove fan.

## INSTALL

| FASTENER                       | TORQUE VALUE |             |
|--------------------------------|--------------|-------------|
| Air duct nut, lower fairing    | 65-75 in-lbs | 7.3-8.4 N-m |
| Air duct screws, lower fairing | 65-75 in-lbs | 7.3-8.4 N-m |

1.
 

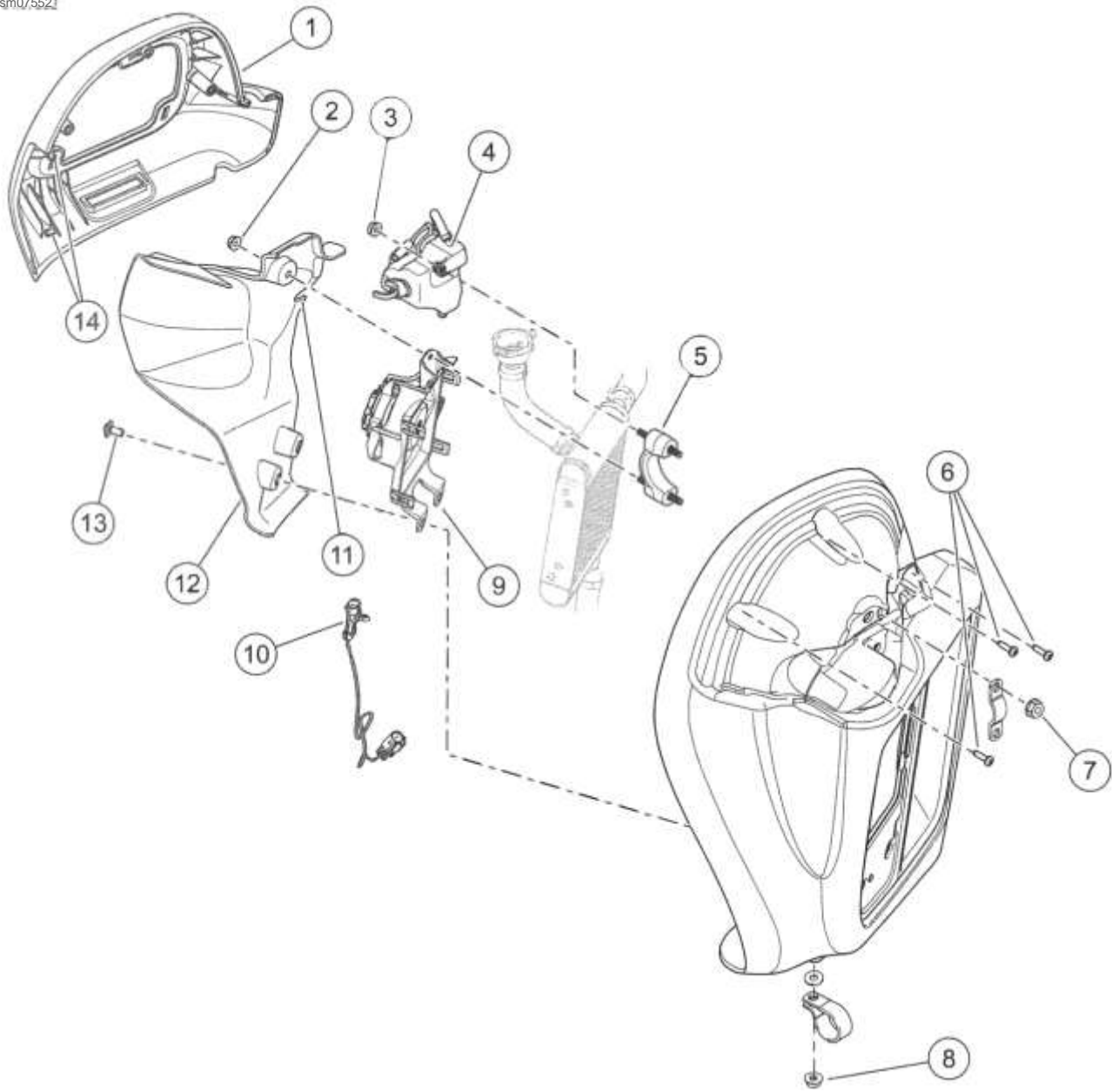
*NOTE*

*The left upper clamp has one stud facing inside. Install single stud at bottom.*

See Figure 8-99. If removed, install upper clamp (5).
2. Latch fan (9) onto radiator.
3. Mate connector (10). Install anchor in fan housing.
 

*NOTE*

*Route overflow vent hose through notch (11) when installing air duct.*
4. Install air duct (12).
  - a. Verify that lower radiator mounts are aligned with bosses.
  - b. Install screws (13). Tighten.  
Torque: 65-75 in-lbs (7.3-8.4 N-m) *Air duct screws, lower fairing*
  - c. Install nut (2). Tighten.  
Torque: 65-75 in-lbs (7.3-8.4 N-m) *Air duct nut, lower fairing*



- |                             |  |
|-----------------------------|--|
| 1. Frame, glove box         | 8. Nut, lower clamp                          |
| 2. Nut, inner air deflector | 9. Fan                                       |
| 3. Nut, coolant bottle      | 10. Connector                                |
| 4. Coolant bottle           | 11. Notch                                    |
| 5. Upper clamp              | 12. Air duct                                 |
| 6. Glove box screws (3)     | 13. Screws, lower, air deflector and fan (2) |
| 7. Nut, upper clamp (2)     | 14. Clips (2)                                |

Figure 8-99. Lower Fairing: Twin-Cooled

**COMPLETE**

| FASTENER                        | TORQUE VALUE |             |
|---------------------------------|--------------|-------------|
| Coolant bottle nut              | 65-74 in-lbs | 7.3-8.4 N-m |
| Glove box screws, lower fairing | 12-16 in-lbs | 1.4—1.8 N-m |
| Lower fairing cap flange nut    | 30-35 in-lbs | 3.4-3.9 N-m |

1. See Figure 8-99. Right side:

- a. Install coolant bottle (4) into rubber grommet and onto stud.

b. Capture filler neck in retainer.

c. Install nut (3). Tighten.

Torque: 65-74 in-lbs (7.3-8.4 N-m) *Coolant bottle nut*

2. Left side: Connect temperature sensor.

3. Move glove box frame (1) into position. Connect vent linkage.



4. Secure glove box frame with screws (6). Tighten.  
Torque: 12-16 in-lbs (1.4-1.8 N-m) *Glove box screws, lower fairing*

**NOTE**

*Lower fairing must be aligned to make sure shift lever and brake pedal do not contact fairing lower vent.*

5. Secure lower fairing to engine guard. See FAIRING LOWERS (Page 3-113).
6. Install lower fairing cap with flange nut. Tighten.  
Torque: 30-35 in-lbs (3.4-3.9 N-m) *Lower fairing cap flange nut*
7. Install access panel.
8. Install main fuse.

## REMOVE \_\_\_\_\_

*NOTE*

See Figure 8-100. The sensor is located at the left steering head caddy on all radio-equipped models.

1. Separate connector from sensor.
2. Pull sensor down to remove from caddy.

## INSTALL \_\_\_\_\_

1. See Figure 8-100. Install **new** sensor.
2. Mate connector.

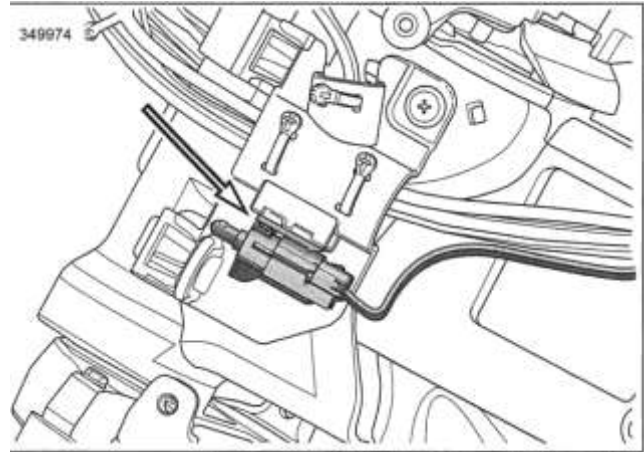


Figure 8-100. Ambient Air Temperature Sensor (FLHTK shown)

## PREPARE

1. Remove left saddlebag. See SADDLEBAGS (Page 3-161).
2. Remove left side cover. See LEFT SIDE COVER (Page 3-62).
3. Remove main fuse. See POWER DISCONNECT (Page 8-8).
4. Twin-cooled: Release lower electrical cover from bottom mounting grommets.

## REMOVE

*NOTE*

CKP sensor connector is fixed to front caddy at bottom of lower frame crossmember.

1. Detach connector from caddy.
2. Separate connector.
3. See Figure 8-101. Remove screw to free CKP sensor. Pull sensor from bore.

## INSTALL

| FASTENER        | TORQUE VALUE  |               |
|-----------------|---------------|---------------|
| CKP mount screw | 90-120 in-lbs | 10.2-13.6 N-m |

1. Install new O-ring on sensor if damaged. Apply a thin film of clean engine oil to O-ring before installation.
2. See Figure 8-101. Install sensor with screw. Tighten.  
Torque: 90-120 in-lbs (10.2-13.6 N-m) CKP mount screw

3. Route connector to front caddy at bottom of lower frame crossmember.
4. Mate connector.
5. Mount connector to caddy T-stud.

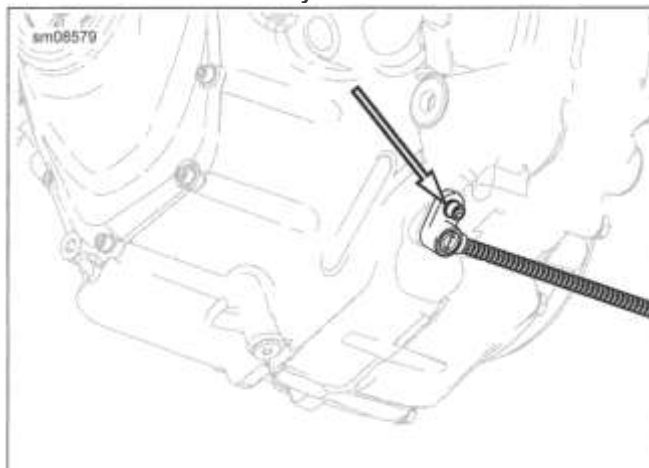


Figure 8-101. CKP Sensor Screw

## COMPLETE

1. Twin-cooled: Push lower electrical cover pins into grommets.
2. Install main fuse. See POWER DISCONNECT (Page 8-8).
3. Install left side cover. See LEFT SIDE COVER (Page 3-62).
4. Install left saddlebag. See SADDLEBAGS (Page 3-161).

## PREPARE

1. Purge fuel line. See PURGE FUEL LINE (Page 6-7).
2. Remove left saddlebag. See SADDLEBAGS (Page 3-161).
3. Remove left side cover. See LEFT SIDE COVER (Page 3-62).
4. Remove main fuse. See POWER DISCONNECT (Page 8-8).
5. Remove seat. See SEAT (Page 3-148).
6. Remove fuel tank. See FUEL TANK (Page 6-10).
7. Remove throttle body. See INDUCTION MODULE (Page 6-26).

## REMOVE

1. See Figure 8-102. Disconnect connector.
2. Remove sensor (3) from rear cylinder head.

## INSTALL

| FASTENER  | TORQUE VALUE |               |
|-----------|--------------|---------------|
| ET sensor | 11-16 ft-lbs | 14.9-21.2 N-m |

1. See Figure 8-102. Install sensor (3). Tighten.  
Torque: 11-16 ft-lbs (14.9-21.2 N-m) *ET sensor*
2. Connect connector.

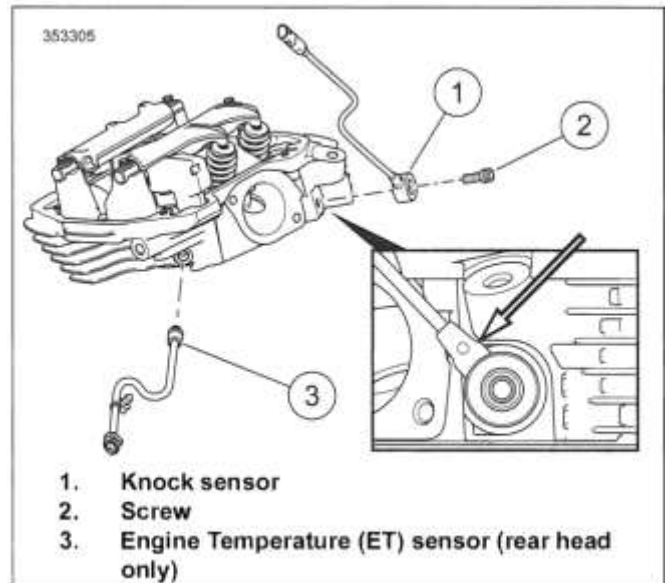


Figure 8-102. Cylinder Head Sensors

## COMPLETE

1. Install throttle body. See INDUCTION MODULE (Page 6-26).
2. Install fuel tank. See FUEL TANK (Page 6-10).
3. Install seat. See SEAT (Page 3-148).
4. Install main fuse. See POWER DISCONNECT (Page 8-8).
5. Install left side cover. See LEFT SIDE COVER (Page 3-62).
6. Install left saddlebag. See SADDLEBAGS (Page 3-161).

## PREPARE

1. Purge fuel line. See FUEL LINE (Page 6-8).
2. Remove left saddlebag. See SADDLEBAGS (Page 3-161).
3. Remove left side cover. See LEFT SIDE COVER (Page 3-62).
4. Remove main fuse. See POWER DISCONNECT (Page 8-8).
5. Remove seat. See SEAT (Page 3-148).
6. Remove fuel tank. See FUEL TANK (Page 6-10).

## REMOVE

1. See Figure 8-103. Remove screw (2).
2. Disconnect connector.
3. Remove sensor (1).

## INSTALL

- a. Install sensor against head casting as shown.

| FASTENER           | TORQUE VALUE |             |
|--------------------|--------------|-------------|
| Knock sensor screw | 13-17 ft-lbs | 17.6-23 N-m |

1. See Figure 8-103. Install sensor (1).

- b. Install screw. Tighten.

Torque: 13-17 ft-lbs (17.6-23 N-m) *Knock sensor screw*

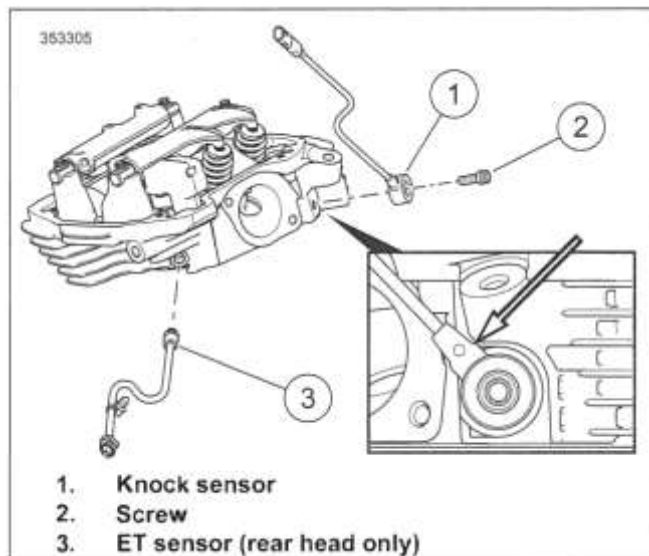


Figure 8-103. Cylinder Head Sensors

## COMPLETE

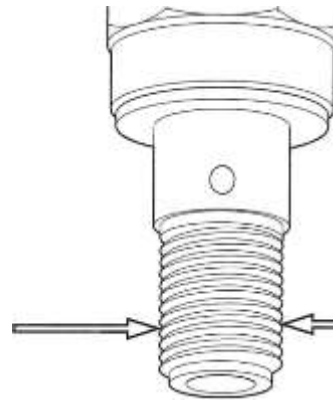
1. Install fuel tank. See FUEL TANK (Page 6-10).
2. Install seat. See SEAT (Page 3-148).
3. Install main fuse. See POWER DISCONNECT (Page 8-8).
4. Install left side cover. See LEFT SIDE COVER (Page 3-62).
5. Install left saddlebag. See SADDLEBAGS (Page 3-161).

## PREPARE

1. Purge fuel line. See PURGE FUEL LINE (Page 6-7).
2. Remove left saddlebag. See SADDLEBAGS (Page 3-161).
3. Remove left side cover. See LEFT SIDE COVER (Page 3-62).
4. Remove main fuse. See POWER DISCONNECT (Page 8-8).
5. Remove seat. See SEAT (Page 3-148).
6. Remove fuel tank. See FUEL TANK (Page 6-10).
7. Remove upper cooling lines. See OIL COOLANT LINES (Page 4-20) or COOLANT HOSES (Page 7-13).

4. See Figure 8-106. Use ACR socket to tighten.  
Torque: 17-19 ft-lbs (23-26.4 N-m) ACR  
Special Tool: ACR SOLENOID SOCKET (HD-48498-B-1)
5. Connect ACR connector.

1205500



## REMOVE

1. Disconnect ACR (Automatic compression release) connector.
2. See Figure 8-106. Remove ACR.

| PART NUMBER  | TOOL NAME           |
|--------------|---------------------|
| HD-48498-B-1 | ACR SOLENOID SOCKET |

| FASTENER | TORQUE VALUE |             |
|----------|--------------|-------------|
| ACR      | 17-19 ft-lbs | 23-26.4 N-m |

| PART NUMBER | CONSUMABLE   |
|-------------|--|
| Loctite 246 | LOCTITE 246 HIGH TEMPERATURE MEDIUM STRENGTH BLUE THREADLOCKER |

## INSTALL

### NOTE

If installing **new** ACR, verify old copper seal washer does not remain in cylinder head.

1. Verify copper seal washer is in place on ACR.
2. See Figure 8-104. Apply threadlocker.  
Consumable: LOCTITE 246 HIGH TEMPERATURE MEDIUM STRENGTH BLUE THREADLOCKER (Loctite 246)
  - a. Identify a location around the threads of the ACR approximately one-third distance from end.
  - b. See Figure 8-105. Apply three equally spaced dots of threadlocker on threads.
3. Install by hand until finger-tight.

Figure 8-104. Bottom Third

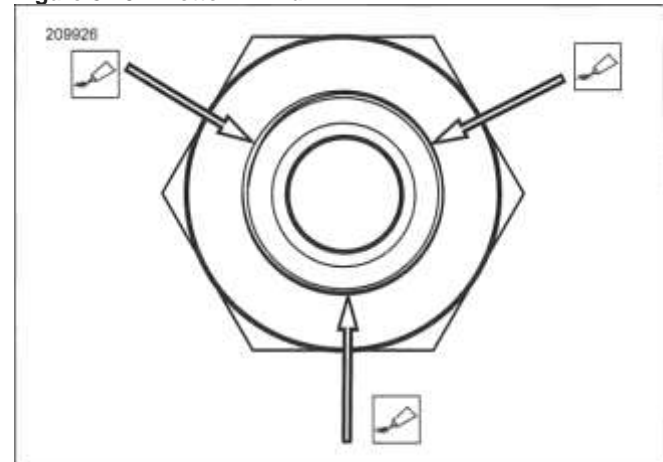


Figure 8-105. Three Dots of Threadlock

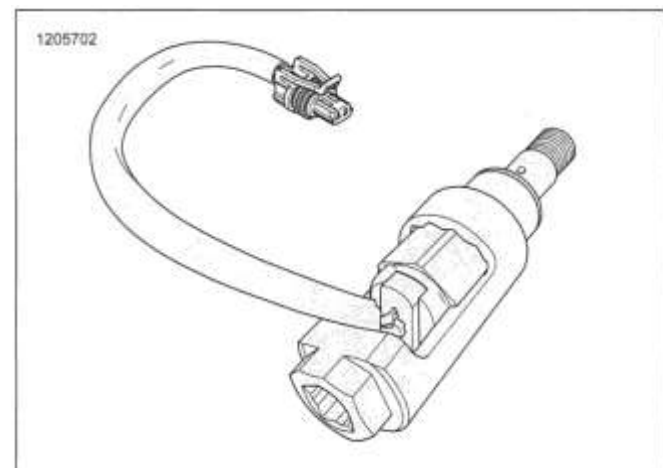


Figure 8-106. ACR Solenoid Socket and ACR

## **COMPLETE**

1. Install upper cooling lines. See OIL COOLANT LINES (Page 4-20) or COOLANT HOSES (Page 7-13).
2. Install fuel tank. See FUEL TANK (Page 6-10).
3. Install seat. See SEAT (Page 3-148).
4. Install main fuse. See POWER DISCONNECT (Page 8-8).
5. Install left side cover. See LEFT SIDE COVER (Page 3-62).
6. Install left saddlebag. See SADDLEBAGS (Page 3-161).

**PREPARE****Prepare**

1. Remove left side cover. See LEFT SIDE COVER (Page 3-62).
2. Remove main fuse. See POWER DISCONNECT (Page 8-8).
3. **Fairing models:** Remove outer fairing. See FAIRING: FORK MOUNTED (Page 3-89) or FAIRING: FRAME MOUNTED (Page 3-100).

**REMOVE****Remove**

1. Note location of cable straps and remove as needed.
2. Release sensor cable from retainers.
3. See Figure 8-107. Separate sensor connector (2).
  - a. **FLH models:** Remove sensor cable from retainer (1) on caddy.
  - b. **FLT models:** Cut cable strap (2) securing sensor cable to brake line.
4. See Figure 8-108. Release sensor cable from clip at caliper:
  - a. Push on lip (1) at rear of clip to disengage from bracket. Rotate tab (2) (stamped ABS) rearward until clip is perpendicular to bracket and remove cable.
  - b. Rotate tab (2) forward until clip is aligned with bracket and apply pressure to tab until lip (1) engages.
5. **NOTE**  
*The WSS works in conjunction with the ABS encoder bearing installed in the wheel hub. If necessary, see SEALED WHEEL BEARINGS (Page 3-26) for bearing removal and installation instructions.*

Retract axle until front WSS is free. See FRONT WHEEL (Page 3-12).

**INSTALL**

2. Secure front wheel. See FRONT WHEEL (Page 3-12). Rotate WSS until it makes contact with fork slider. Back off

**Installation**

1. **NOTE**  
*Install WSS with index pin on outboard side.*

Push axle through **new** front WSS and left fork slider.

just enough to maintain clearance between the WSS wire stem and fork slider.

3. Route sensor cable up to lower fork bracket following brake hose.
4. Route connector up through opening in lower fork bracket.
5. **FLT models:** Route cable between the upper and lower legs of inner fairing mounting bracket to the right steering head caddy.
6. See Figure 8-107. Continue to right steering head caddy. Mate connector.
  - a. **FLH models:** Secure connector on retainer (1) on caddy.
  - b. **FLT models:** Secure sensor cable to brake line just below the caddy with **new** cable strap (2).
7. Secure the sensor cable and fender tip lamp wires using three **new** cable straps:
  - a. On the brake hose lower crimp capturing WSS cable and brake hose.
  - b. Midway between the upper and lower brake hose crimps capturing WSS cable, brake hose and front fender tip lamp wires, if equipped.
  - c. On upper crimp capturing WSS cable, brake hose and front fender tip lamp wires, if equipped.
8. See Figure 8-108. Install WSS cable in retaining clip:
  - a. Push on lip (1) at rear of retaining clip to disengage from bracket. Rotate tab (2) (stamped ABS) rearward until retaining clip is perpendicular to bracket. Install cable.
  - b. Rotate tab (2) forward and apply pressure until lip (1) engages. Gently tug on cable to verify that retaining clip is properly installed.
9. **Fairing models:** Capture WSS cable to three retainers on brake hoses near steering head. Install outer fairing. See FAIRING: FORK MOUNTED (Page 3-89) or FAIRING: FRAME MOUNTED (Page 3-100).



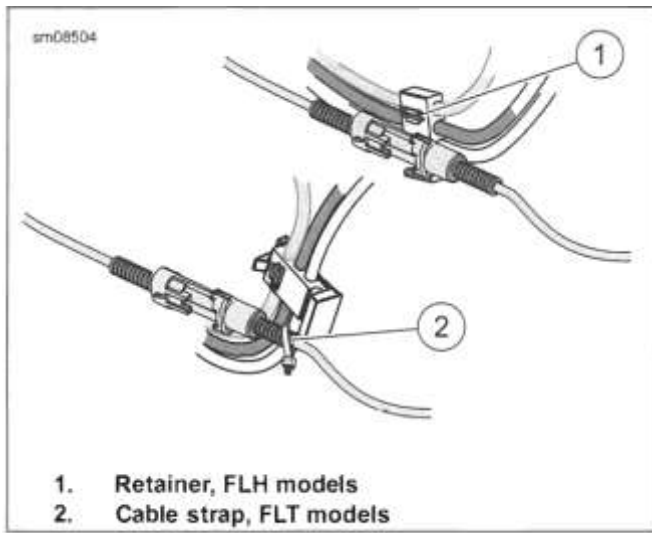


Figure 8-107. Front WSS Connector

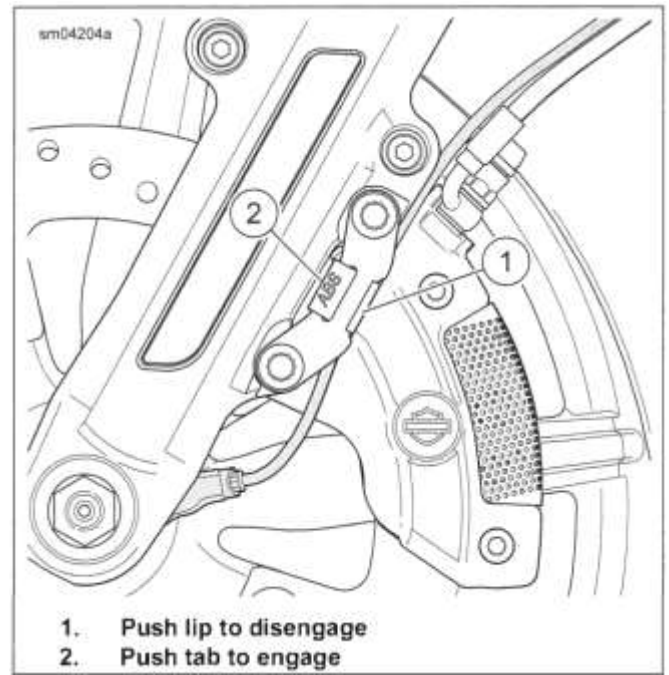


Figure 8-108. Front Wheel Speed Sensor Cable Clip

## COMPLETE

### Complete

1. **Fairing models:** Install outer fairing. See FAIRING: FORK MOUNTED (Page 3-89) or FAIRING: FRAME MOUNTED (Page 3-100).
2. Install main fuse. See POWER DISCONNECT (Page 8-8).
3. Install left side cover. See LEFT SIDE COVER (Page 3-62).

## PREPARE

1. Remove left saddlebag. See SADDLEBAGS (Page 3-161).
2. Remove left side cover. See LEFT SIDE COVER (Page 3-62).
3. Remove main fuse. See POWER DISCONNECT (Page 8-8).
4. Remove right saddlebag. See SADDLEBAGS (Page 3-161).
5. Remove right side cover. See RIGHT SIDE COVER (Page 3-63).

## REMOVE

### NOTE

- Always keep wheel speed sensor (WSS,) and ABS encoder bearing away from magnetic fields. Magnetic items will damage sensor.
- Never pull WSS cable taut or use to retain wheel, axle or other components.

1. Release rear WSS connector from anchor on right side caddy.
2. Disconnect connector.
3. Release rear WSS cable from two cable retainers and conduit clip secured to brake hose.
4. Retract axle until rear WSS is free. See REAR WHEEL (Page 3-14).

### NOTE

The WSS works in conjunction with the ABS encoder bearing installed in the wheel hub. If necessary, see SEALED WHEEL BEARINGS (Page 3-26) for bearing removal and installation instructions.

## INSTALL

1. See Figure 8-109. Hold **new** rear WSS in place with index pin outboard toward rear fork, and push axle through sensor, caliper bracket and right side of rear fork.
2. Secure rear wheel. See REAR WHEEL (Page 3-14).
3. See Figure 8-109. Rotate rear WSS until index pin makes contact with caliper bracket at point shown.
4. Route rear WSS cable forward along top of rear fork.
5. Capture rear WSS cable and brake hose in cable retainers on top of rear fork.
6. Secure cable to brake hose with conduit clip placed specified distance ahead of the rear brake hose crimp.  
1.25 in (31.8 mm)
7. Route cable to outboard side of right side caddy.

8. Mate connectors and secure to anchor.

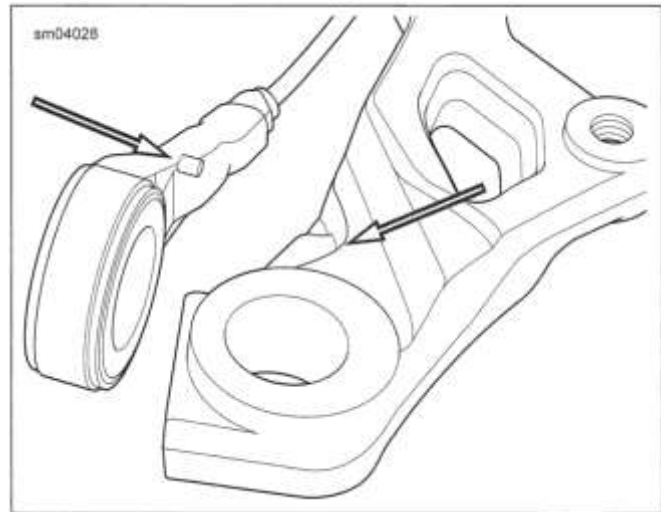


Figure 8-109. Rear Wheel Speed Sensor Index Pin

## COMPLETE

1. Adjust belt tension. See INSPECT AND ADJUST DRIVE BELT AND SPROCKETS (Page 2-37).
2. Install right side cover. See RIGHT SIDE COVER (Page 3-63).
3. Install right saddlebag. See SADDLEBAGS (Page 3-161).
4. Install main fuse. See POWER DISCONNECT (Page 8-8).
5. Install left side cover. See LEFT SIDE COVER (Page 3-62).
6. Install left saddlebag. See SADDLEBAGS (Page 3-161).

**PREPARE.**

1. Remove left saddlebag. See SADDLEBAGS (Page 3-161).
2. Remove left side cover. See LEFT SIDE COVER (Page 3-62).
3. Remove main fuse. See POWER DISCONNECT (Page 8-8).
4. Remove right saddlebag. See SADDLEBAGS (Page 3-161).
5. Remove right side cover. See RIGHT SIDE COVER (Page 3-63).

**REMOVE**

1. See Figure 8-110. Disconnect IMU connector (3).

2. Remove screws (1).

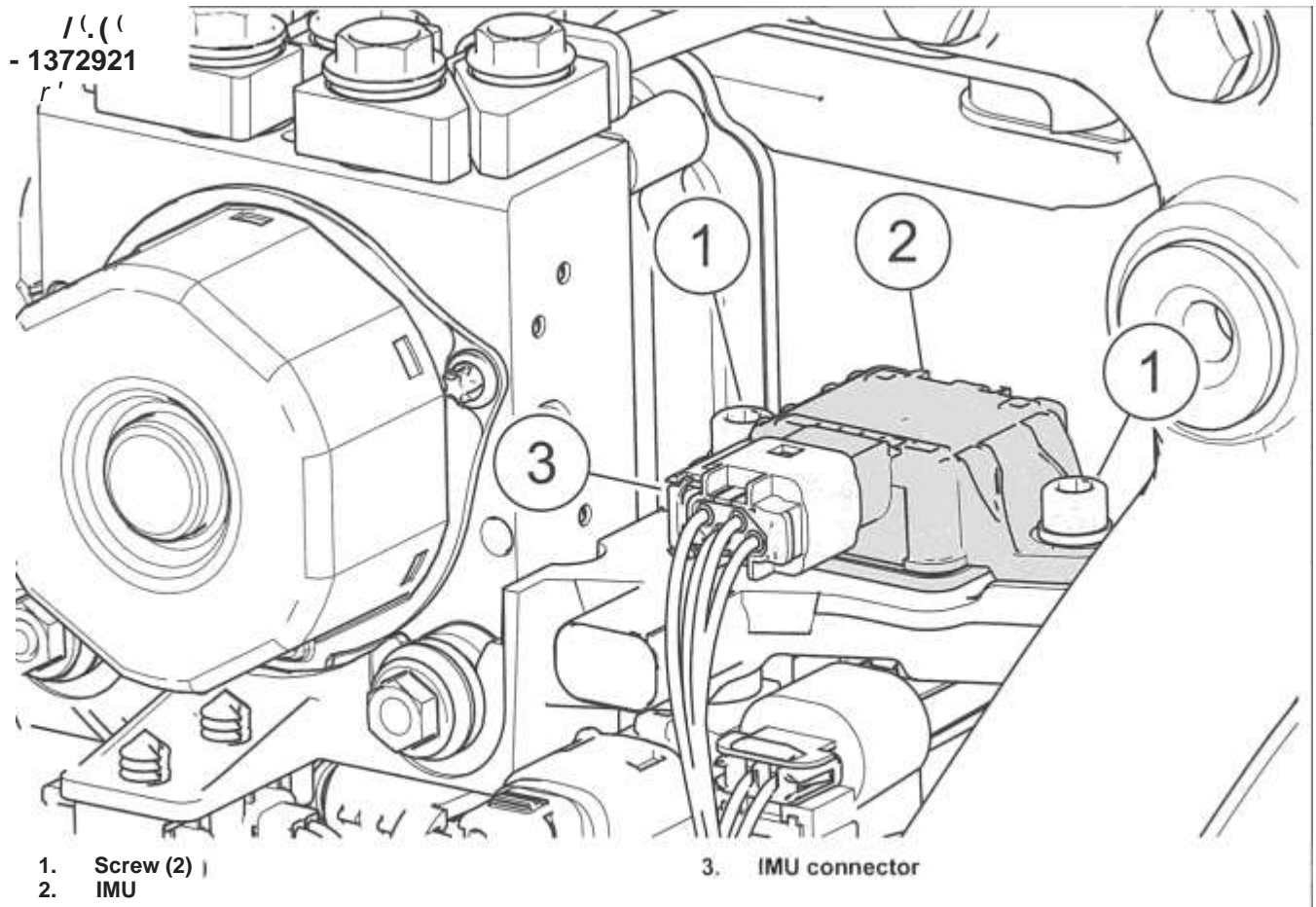
**INSTALL**

| FASTENER  | TORQUE VALUE |             |
|-----------|--------------|-------------|
| IMU screw | 32-40 in-lbs | 3.6-4.5 N-m |

1. See Figure 8-110. Install screws (1) through IMU (2). Tighten.

Torque: 32-40 **in-lbs** (3.6--4.5 N-m) *IMU screw*

2. Connect IMU connector (3) to IMU.



1. Screw (2)
2. IMU

3. IMU connector

**Figure 8-110. IMU Mounting**

**COMPLETE**

1. Install right side cover. See RIGHT SIDE COVER (Page 3-63).
2. Install right saddlebag. See SADDLEBAGS (Page 3-161).

3. Install main fuse. See POWER DISCONNECT (Page 8-8).

4. Install left side cover. See LEFT SIDE COVER (Page 3-62).
5. Install left saddlebag. See SADDLEBAGS (Page 3-161).

**PREPARE**

1. Remove left saddlebag. See SADDLEBAGS (Page 3-161).
2. Remove left side cover. See LEFT SIDE COVER (Page 3-62).
3. Remove main fuse. See POWER DISCONNECT (Page 8-8).
4. Remove lower electrical cover below voltage regulator.

**REMOVE**

1. Push anchor on sensor connector from hole in front frame cross member.
2. Disconnect connector.
3. Release wire from retention clip.
4. Move jiffy stand to full forward (down) position.
5. See Figure 8-111. Remove fastener (3). Pull sensor from jiffy stand bracket.

**INSTALL**

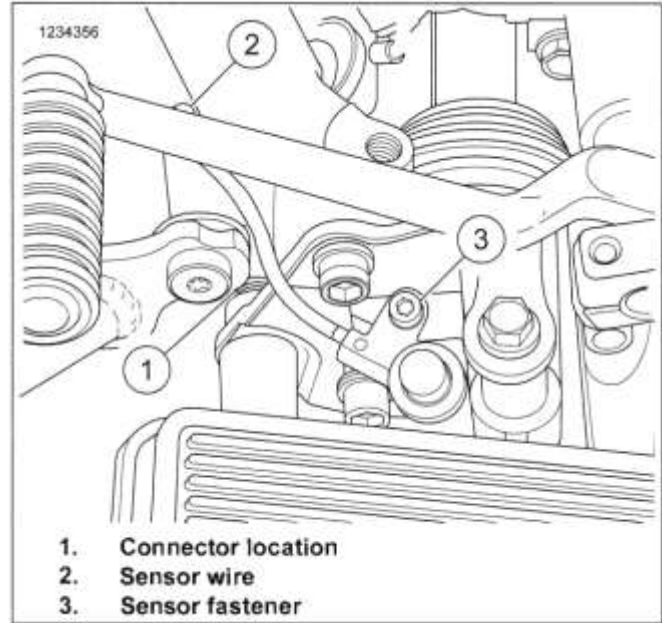
2. See Figure 8-111. Install sensor into bore of jiffy stand

| FASTENER                 | TORQUE VALUE  |               |
|--------------------------|---------------|---------------|
| Jiffy stand sensor screw | 96-120 in-lbs | 10.8-13.6 N-m |

| PART NUMBER | CONSUMABLE  |
|-------------|---|
| 99642-97    | LOCTITE 243 MEDIUM STRENGTH THREADLOCKER AND SEALANT (BLUE) |

1. Move jiffy stand to full forward (down) position.  
  
bracket.
3. If reusing fastener (3), apply a small dab of threadlocker and sealant to threads before installation.  
  
Consumable: LOCTITE 243 MEDIUM STRENGTH THREADLOCKER AND SEALANT (BLUE) (99642-97)

4. Install fastener. Tighten.  
Torque: 96-120 in-lbs (10.8-13.6 N-m) *Jiffy stand sensor screw*
5. Route wire over top of frame weldment, as shown, to area below voltage regulator.
6. Anchor wire in retention clip.
7. Connect sensor connector and push anchor into hole in front frame cross member.



**Figure 8-111. Jiffy Stand Interlock Sensor**

**COMPLETE**

1. Install lower electrical cover.
2. Install main fuse. See POWER DISCONNECT (Page 8-8).
3. Verify jiffy stand sensor operation.
4. Install left side cover. See LEFT SIDE COVER (Page 3-62).
5. Install left saddlebag. See SADDLEBAGS (Page 3-161).

**PREPARE**

1. Purge fuel line. See PURGE FUEL LINE (Page 6-7).
2. Remove left saddlebag. See SADDLEBAGS (Page 3-161).
3. Remove left side cover. See LEFT SIDE COVER (Page 3-62).
4. Remove main fuse. See POWER DISCONNECT (Page 8-8).
5. Remove fuel tank. See FUEL TANK (Page 6-10).
6. Remove air cleaner and backplate. See AIR CLEANER BACKPLATE ASSEMBLY (Page 6-3).
7. Remove each cable strap from slots in wire trough. Remove tail remnant from eyelet.
8. Install cable strap back on harness near painted lines to gather bunch of wires. Verify all wires are captured.
9. Pull breakout harnesses out through slot in breakout compartment. If ABS equipped, move harnesses outboard of brake lines.
10. **FLHR/C:** Remove fuel gauge harness from slot in front of wire trough.
11. Pry anchor pins at rear of wire trough from holes in frame backbone.
12. Remove wire trough.

**REMOVE**

1. Remove TMAP sensor connector [80].
  - a. Pull back yellow lock.
  - b. Push down firmly on latch.
  - c. Disconnect connector.
2. Disconnect fuel injector connectors.
3. Disconnect TCA connector [211]. Release anchored cable strap securing harness to induction module.
4. Disconnect ACR connectors and release connector housings from induction module support.
5. Disconnect knock sensor connectors.
6. Disconnect terminals from horn and release harness from J-clamp. Release cable straps securing harness to horn bracket.
7. Disconnect ET sensor connector [90].
8. Draw connectors to right side of motorcycle.
9. **ABS models:** Release brake lines from wire trough.
10. See Figure 8-112. Cut two cable straps to release breakout harnesses from right side of wire trough.
11. Remove wire trough cover.
12. See Figure 8-113. Using a paint pen, draw a line on both sides of each cable strap securing wire bundles.
13. **NOTE**  
See Figure 8-114. When removing cable straps, cut off the tail, not the eyelet. The cable strap can then be reused to gather wires when removing harness from wire trough.
  - a. Cut tails of cable straps as close to eyelet as possible.

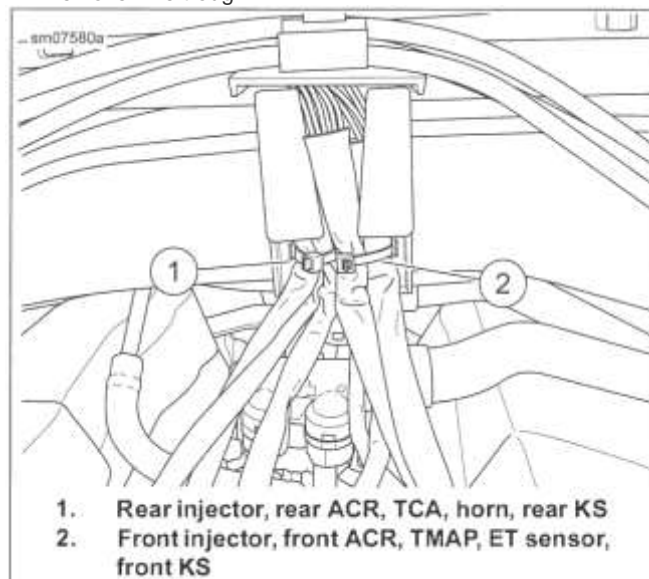


Figure 8-112. Breakout Harnesses

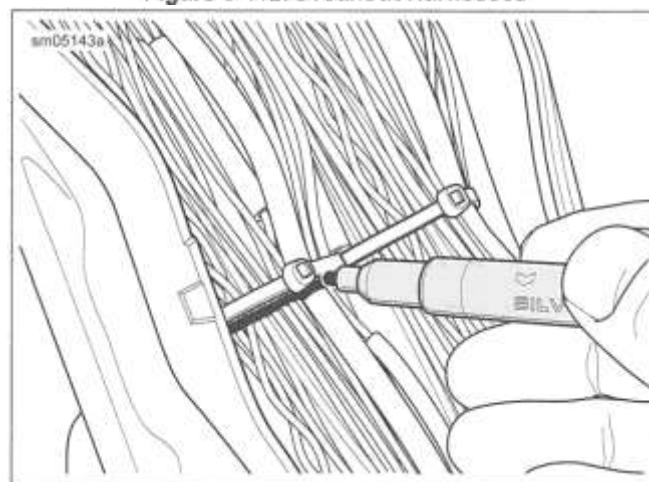
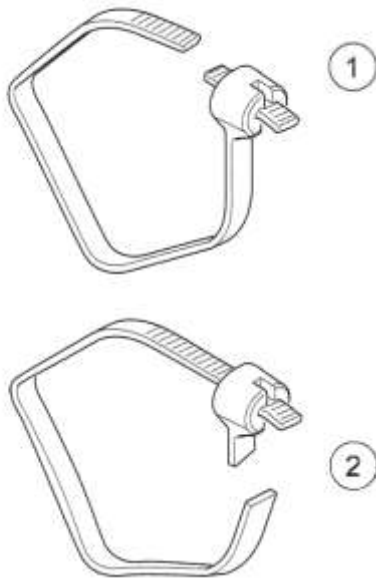


Figure 8-113. Mark Location of Cable Straps



1. Reusable (tail removed)
2. Not reusable (eyelet removed)

Figure 8-114. Cut Cable Straps

## INSTALL

1. Thread six **new** cable straps through slots inside wire trough.
2. Slide wire trough into position.
3. Route forward branches through channels in trough.
4. **Road King models:** Route fuel gauge harness through slot in front-left of wire trough.
5. See Figure 8-112. Secure breakout harnesses in rear of breakout compartment with **new** cable strap. Do not tighten.
  - a. Rear fuel injector
  - b. Rear ACR
  - c. TCA
  - d. Rear knock sensor
  - e. Horn
6. Secure breakout harnesses in front of breakout compartment with **new** cable strap. Do not tighten.
  - a. Front fuel injector
  - b. Front ACR
  - c. ET sensor
  - d. Front knock sensor
  - e. TMAP
7. **ABS models:** Pull breakout harnesses inboard of brake lines.
8. Adjust harness wires inside wire trough so they are positioned within the cable straps. Install each cable strap but do not tighten.
9. Remove cable straps used to gather wire bunches.
10. Secure rear of wire trough into holes in frame backbone.
11. Align the painted lines with the cable straps. Tighten and trim cable straps.
12. Align the painted lines on branches exiting breakout compartment with cable straps. Tighten and trim cable straps.
13. Secure cover to wire trough starting at the rear and working forward. Verify that all latches are fully engaged.
14. **ABS models:** Secure brake lines as shown in Figure 3-53.
15. Connect TMAP sensor connector. Engage yellow lock.
16. Connect rear fuel injector connector, front fuel injector connector, ET sensor connector and knock sensor connectors.
17. Install terminals onto horn contacts. Capture horn harness in J-clamp. Secure harness to horn bracket with cable straps.
18. Connect TCA connector. Secure harness to induction module with **new** anchored cable strap.
19. Connect ACR connectors.
  20. Secure knock sensor connectors, ACR connectors and ET sensor connector to lower backbone caddy.

## COMPLETE

1. Install air cleaner and backplate. See AIR CLEANER BACKPLATE ASSEMBLY (Page 6-3).
2. Install fuel tank. See FUEL TANK (Page 6-10).
3. Install main fuse. See POWER DISCONNECT (Page 8-8).
4. Install left side cover. See LEFT SIDE COVER (Page 3-62).
5. Install left saddlebag. See SADDLEBAGS (Page 3-161).

**TOP CADDY**  
**PREPARE**

1. Remove left saddlebag. See SADDLEBAGS (Page 3-161).
2. Remove left side cover. See LEFT SIDE COVER (Page 3-62).
3. Remove main fuse. See POWER DISCONNECT (Page 8-8).
4. Remove seat. See SEAT (Page 3-148).
5. Detach security system antenna. See SECURITY SYSTEM ANTENNA (Page 8-90).
6. Detach top connector. See .
7. Detach bottom connector. See .
8. Detach purge solenoid or purge solenoid connector. See
  
9. Detach ECM. See ELECTRONIC CONTROL MODULE (ECM) (Page 8-83).

**REMOVE**

1. See Figure 8-115. Remove screws (2).
2. Remove top caddy (1) from tab (3).

**INSTALL**

1. See Figure 8-115. Place top caddy (1) in position on tab (3).

| FASTENER         | TORQUE VALUE |              |
|------------------|--------------|--------------|
| Top caddy screws | 72-96 in-lbs | 8.1-10.9 N-m |

2. Install screws (2). Tighten.

Torque: 72-96 in-lbs (8.1-10.9 N-m) *Top caddy screws*

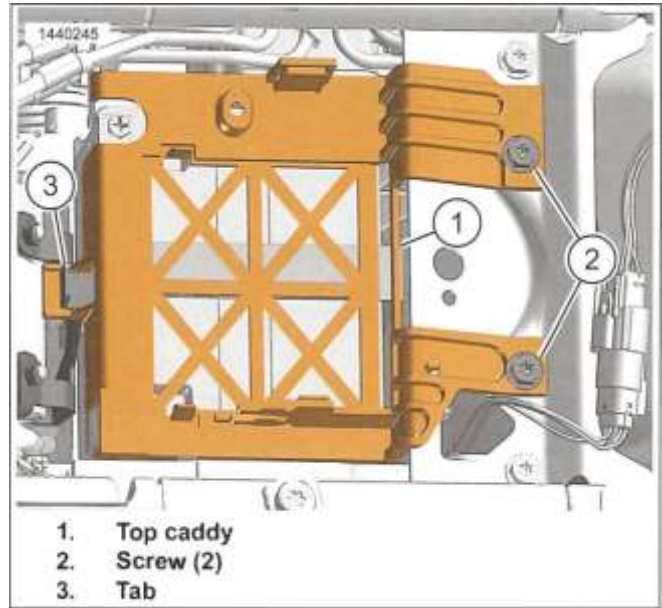


Figure 8-115. Top Caddy

**COMPLETE**

1. Attach ECM. See ELECTRONIC CONTROL MODULE (ECM) (Page 8-83).
2. Attach purge solenoid or purge solenoid connector. See .
3. Attach bottom connector. See .
4. Attach top connector. See .
5. Install security system antenna. See SECURITY SYSTEM ANTENNA (Page 8-90).
6. Install seat. See SEAT (Page 3-148).
7. Install main fuse. See POWER DISCONNECT (Page 8-8).
8. Install left side cover. See LEFT SIDE COVER (Page 3-62).
9. Install left saddlebag. See SADDLEBAGS (Page 3-161).

## PREPARE

1. Remove left saddlebag. See SADDLEBAGS (Page 3-161).
2. Remove left side cover. See LEFT SIDE COVER (Page 3-62).
3. Remove seat. See SEAT (Page 3-148).
4. Siren Equipped Models: With security fob present, turn ignition switch ON.
5. Remove main fuse. See POWER DISCONNECT (Page 8-8).
6. Disconnect rear fender lights harness connector.
7. Remove connector from retaining device.

## REMOVE

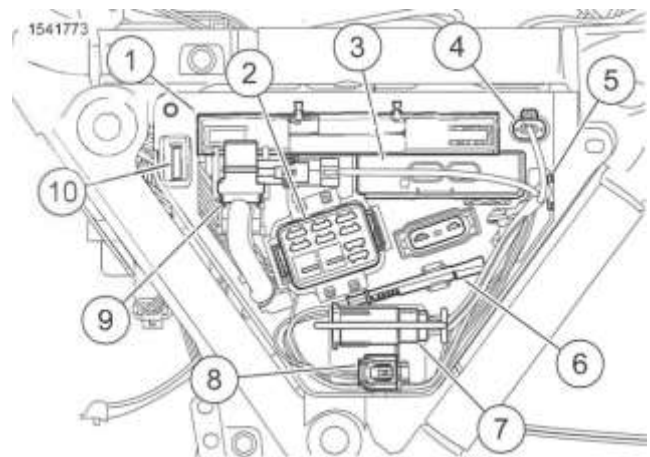
1. See Figure 8-116. Remove BCM (1). See BODY CONTROL MODULE (BCM) (Page 8-84).
2. Remove siren (3), if equipped. If not equipped, remove connector from storage location (4) on caddy.
- 3.
4. Release data link connector (8), auxiliary device connector (7) and battery tender connector (6) from caddy.  
  
Remove fuse block cover.
5. Remove two screws securing caddy.
6. Remove cable straps (5, 9, 10).
7. Pull harnesses back through openings in caddy.
8. Use a thin tool to release four latches (2) securing fuse block. Push fuse block back through opening in caddy.
9. From back side of caddy, squeeze tabs of main fuse holder and pull away from caddy.

## INSTALL

| FASTENER          | TORQUE VALUE |              |
|-------------------|--------------|--------------|
| Left caddy screws | 72-96 in-lbs | 8.1-10.9 N-m |

1. See Figure 8-116. Route harnesses through openings.
2. Loosely install a new cable strap (9) on the BCM harness.
3. Loosely secure main harness to anchor on back side of caddy with cable strap (10).
4. Install main fuse holder into caddy. Confirm that latches on fuse holder are secured to caddy.

3. Insert fuse block from back side of caddy. Confirm latches (2) are secured to fuse block.
4. Loosely secure BCM harness to tab with previously installed cable strap (9).
5. Loosely secure harnesses to tab at rear opening with a cable strap (5).
6. **NOTE**  
*Tighten cable straps only enough to secure harnesses but still allow movement.*  
  
Tighten main harness, BCM harness then rear harness cable straps until snug.
7. Route rear fender lights connector through opening in battery tray and up through opening in frame.
8. Secure caddy with two screws. Tighten.  
Torque: 72-96 in-lbs (8.1-10.9 N-m) *Left caddy screws*
9. Secure auxiliary device connector (7), data link connector (8), and battery tender connector (6) to caddy.
10. Install fuse block cover.
11. Install siren (3) and attach electrical connector, if equipped.  
  
If not equipped, attach connector to storage location (4).
14. Connect and install BCM (1). See BODY CONTROL MODULE (BCM) (Page 8-84).



1. BCM
2. Fuse block latch locations (lower two are not visible)
3. Siren (if equipped)
4. Siren connector storage
5. Cable strap, rear
6. Battery tender connector
7. Auxiliary device connector
8. Data link connector
9. Cable strap, BCM harness
10. Cable strap, main harness

Figure 8-116. Caddy Components



## **COMPLETE**

---

4.

Install seat. See SEAT (Page 3-148).

1. Connect rear fender lights harness connector.
2. Secure to retaining device.
3. Install main fuse. See POWER DISCONNECT (Page 8-8).
5. Install left side cover. See LEFT SIDE COVER (Page 3-62).
6. Install left saddlebag. See SADDLEBAGS (Page 3-161).

## PREPARE

1. Remove left saddlebag. See SADDLEBAGS (Page 3-161).
2. Remove left side cover. See LEFT SIDE COVER (Page 3-62).
3. Remove main fuse. See POWER DISCONNECT (Page 8-8).
4. Remove seat. See SEAT (Page 3-148).
5. Remove top caddy and battery. See INSPECT BATTERY (Page 2-48).
6. Remove right saddlebag. See SADDLEBAGS (Page 3-161).
7. Remove right side cover. See RIGHT SIDE COVER (Page 3-63).
8. Remove IMU. See INERTIAL MEASUREMENT UNIT (IMU) (Page 8-103).

## REMOVE

1. Detach HO2S sensor connectors.
2. See Figure 8-117. Detach CAN termination resistor connector (3).
3. Detach P&A connector (2).
4. Detach wheel speed sensor connector.
5. Remove ignition coil screws and battery hold-down bracket.
6. Remove screw (1) securing right side caddy to battery tray.
7. Remove four screws securing battery tray to frame.
8. Disengage latch on bottom of caddy. Release caddy from dovetails while lowering battery tray into frame.

9. **NOTE**  
Pry between bottom of ABS module and right caddy to release stud on bottom of module from grommet.

**ABS models:** Loosen nuts securing ABS module (4) to caddy.

10. Remove ABS module from caddy.
11. Remove caddy.

## INSTALL

| FASTENER                          | TORQUE VALUE        |             |
|-----------------------------------|---------------------|-------------|
| Right caddy to battery tray screw | 36-40 <b>in-lbs</b> | 4.1-4.5 N-m |

1. **NOTE**

Apply glass cleaner to grommets to aid installation.

ABS models: Install ABS module to ABS module caddy.

2. Install nuts. Tighten.  
Torque: 53-88 **in-lbs** (6-9.9 N-m) *ABS module locknuts*
3. Engage right side caddy onto dovetails while lifting battery tray up into position. Verify latch on bottom of caddy is engaged.
4. See Figure 8-117. Install screw (1). Tighten.  
Torque: 36-40 **in-lbs** (4.1-4.5 N-m) *Right caddy to battery tray screw*
5. Install four screws securing battery tray to frame. See BATTERY TRAY (Page 8-113).
6. Install battery hold-down bracket and screws to secure ignition coil. See IGNITION COIL (Page 8-20).

7. **NOTE**

Locate gray connector in outboard position.

Attach HO2S sensor connectors.

8. Attach wheel speed sensor connector.
9. Attach CAN termination resistor connector (3).

10. Attach P&A connector (2).

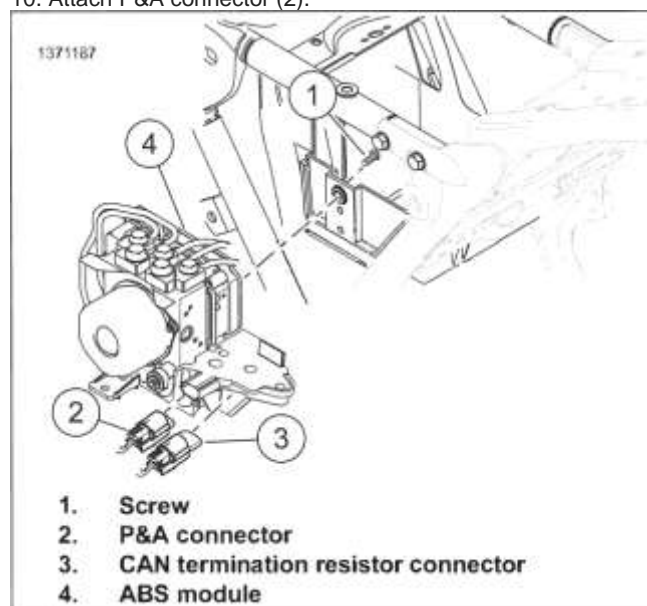


Figure 8-117. Right Side Caddy

| FASTENER            | TORQUE VALUE        |           |
|---------------------|---------------------|-----------|
| ABS module locknuts | 53-88 <b>in-lbs</b> | 6-9.9 N-m |

## **COMPLETE**

1. Install IMU. See INERTIAL MEASUREMENT UNIT (IMU) (Page 8-103).
2. Install right side cover. See RIGHT SIDE COVER (Page 3-63).
3. Install right saddlebag. See SADDLEBAGS (Page 3-161).
4. Install battery and top caddy. See INSPECT BATTERY (Page 2-48).
5. Install seat. See SEAT (Page 3-148).
6. Install main fuse. See POWER DISCONNECT (Page 8-8).
7. Install left side cover. See LEFT SIDE COVER (Page 3-62).
8. Install left saddlebag. See SADDLEBAGS (Page 3-161).

## PREPARE

1. Purge fuel line. See PURGE FUEL LINE (Page 6-7)
2. Remove left saddlebag. See SADDLEBAGS (Page 3-161)
3. Remove left side cover. See LEFT SIDE COVER (Page 3-62)
4. Remove main fuse. See POWER DISCONNECT (Page 8-8)
5. Remove fuel line from fuel tank. See FUEL LINE (Page 6-8)
6. Remove seat. See SEAT (Page 3-148)
7. Remove console. See CONSOLE (Page 6-5)
8. Remove fuel tank. See FUEL TANK (Page 6-10)

1. Plastic rivet (2)
2. Rear Automatic Compression Release (ACR) connector
3. Rear Knock Sensor (KS) connector
4. Front KS connector
5. Front ACR connector

## REMOVE

1. See Figure 8-118. Disconnect electrical connectors (2, 3, 4, 5, 7).
2. Remove caddy.
  - a. Remove two plastic rivets (1).
  - b. Slide caddy forward and down to remove.
3. Cut cable straps (8).

## INSTALL

1. See Figure 8-118. Connect electrical connectors (2, 3, 4, 5, 7).
2. Install new cable straps (8).
3. Install caddy.
  - a. Slide caddy up and rearward to engage latches.
  - b. Install two plastic rivets (1).
6. Hook
7. ET sensor connector
8. Cable strap (3)
9. Horn wires

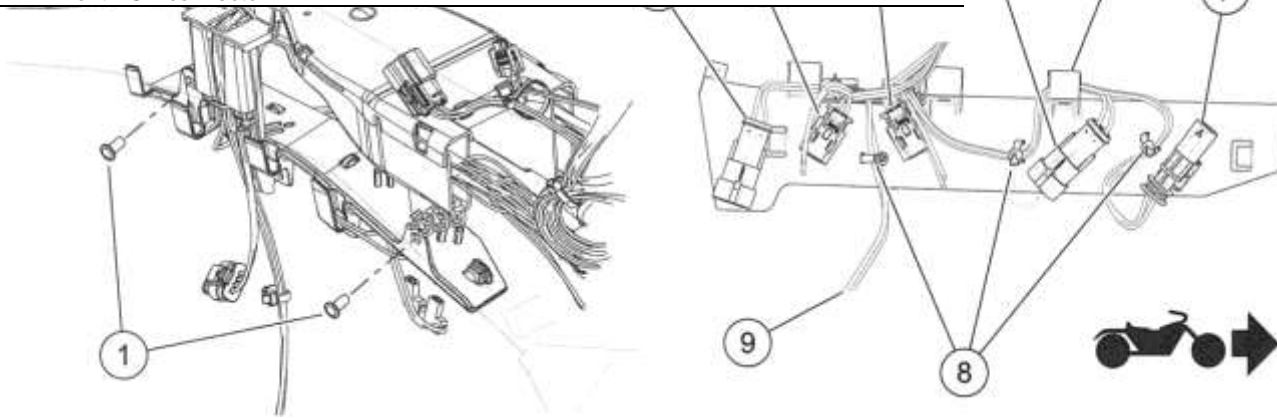


Figure 8-118. Lower Backbone Caddy

## COMPLETE

1. Install fuel tank. See FUEL TANK (Page 6-10)
2. Install fuel line on fuel tank. See FUEL LINE (Page 6-8)
3. Install console. See CONSOLE (Page 6-5)
4. Install seat. See SEAT (Page 3-148)
5. Install main fuse. See POWER DISCONNECT (Page 8-8)
6. Install left side cover. See LEFT SIDE COVER (Page 3-62)
7. Install left saddlebag. See SADDLEBAGS (Page 3-161)

## PREPARE

1. Remove seat. See SEAT (Page 3-148)
2. Disconnect negative battery cable. See POWER DISCONNECT (Page 8-8)
3. Remove left side cover. See LEFT SIDE COVER (Page 3-62)
4. Remove left side caddy screws. See LEFT SIDE CADDY (Page 8-108)
5. Remove ignition coil screws. See IGNITION COIL (Page 8-20)
6. Remove right side cover. See RIGHT SIDE COVER (Page 3-63)
7. **Vehicle with right side caddy:** Remove right side caddy screw. See RIGHT SIDE CADDY (Page 8-110)

## REMOVE

1. Position left side caddy.
  - a. Pull left side caddy away from frame while pulling rear fender lights harness out through battery tray.
2. Remove battery hold-down bracket.
3. **Vehicle without right side caddy:** Release connectors from retaining devices.
4. Remove battery tray.
  - a. Remove four screws securing battery tray.
  - b. **Vehicle with right side caddy:** Disengage latch on bottom of caddy.
  - c. **Vehicle with right side caddy:** Release caddy from dovetails while lowering battery tray into frame.
  - d. Roll front of battery tray up and out of frame.

## INSTALL

| FASTENER                    | TORQUE VALUE |               |
|-----------------------------|--------------|---------------|
| Battery tray to frame screw | 11-13 ft-lbs | 14.9-17.6 N-m |

1. Install battery tray.
  - a. Roll rear of battery tray down into frame.
  - b. **Models with right side caddy:** Engage right side caddy onto dovetails while lifting battery tray up into position.
  - c. **Models with right side caddy:** Verify latch on bottom of caddy is engaged.
  - d. Install battery tray to frame screws. Tighten.  
Torque: 11-13 ft-lbs (14.9-17.6 N-m) *Battery tray to frame screw*
2. **Models without right side caddy:** Secure connectors to retaining devices.
3. Install battery hold-down bracket.
4. Position lift side caddy.
  - a. Route rear fender lights connector through opening in battery tray and up through opening in frame.

## COMPLETE

1. **Vehicle with right side caddy:** Install right side caddy screw. See RIGHT SIDE CADDY (Page 8-110)
2. Install right side cover. See RIGHT SIDE COVER (Page 3-63)
3. Install ignition coil screws. See IGNITION COIL (Page 8-20)
4. Install left side caddy screws. See LEFT SIDE CADDY (Page 8-108)
5. Install left side cover. See LEFT SIDE COVER (Page 3-62)
6. Connect negative battery cable. See POWER DISCONNECT (Page 8-8)
7. Install seat. See SEAT (Page 3-148)

## PREPARE

1. Remove left saddlebag. See SADDLEBAGS (Page 3-161).
2. Remove left side cover. See LEFT SIDE COVER (Page 3-62).
3. Remove main fuse. See POWER DISCONNECT (Page 8-8).
4. Remove Tour-Pak liner. See TOUR-PAK (Page 3-153).
5. Remove Tour-Pak. See TOUR-PAK (Page 3-153).

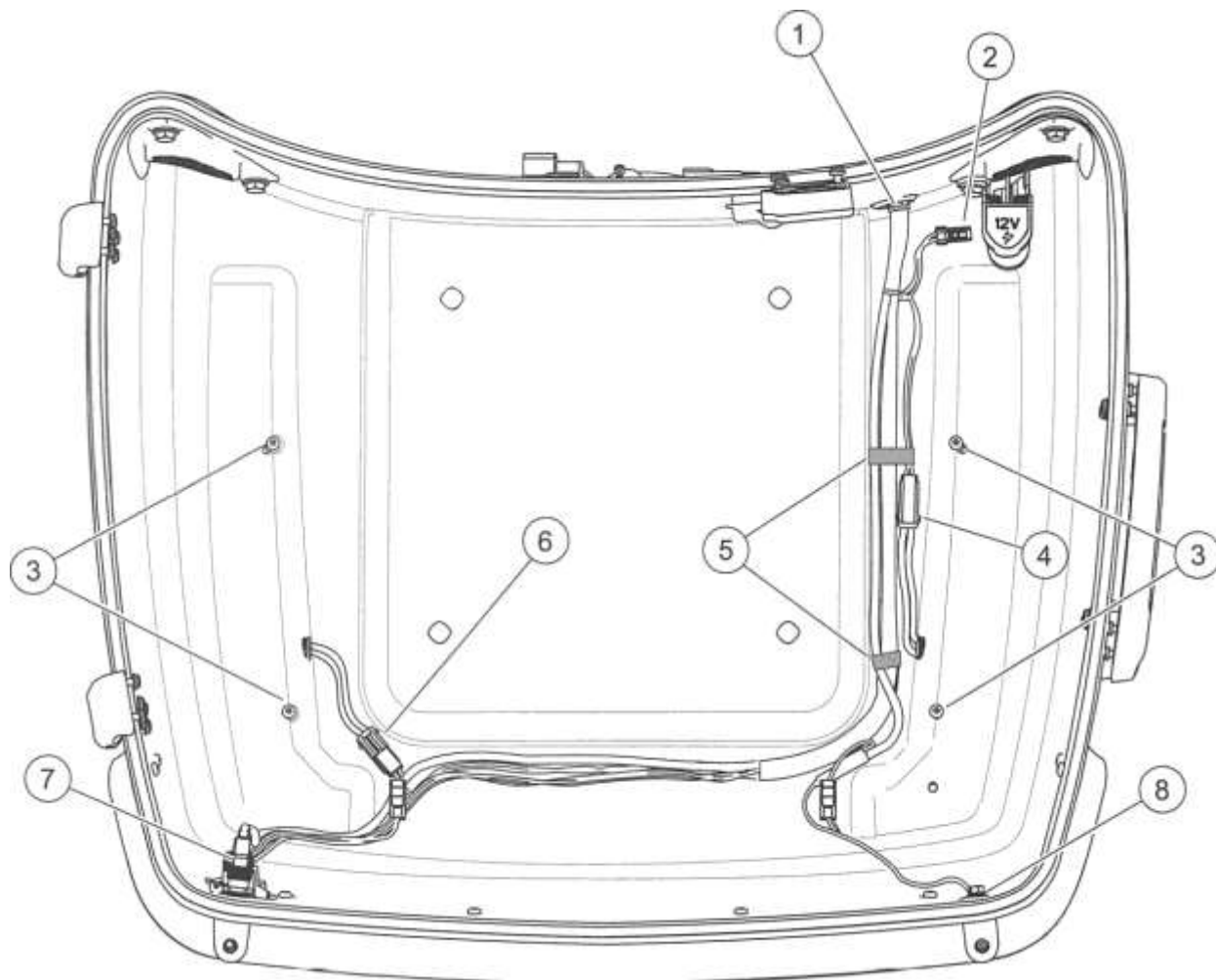
## REMOVE

1. See Figure 8-119. Remove radio antenna cable (7).
2. Remove nut, washer and ring terminal securing CB antenna cable (8).
3. Disconnect two ground connectors.
4. Disconnect side marker lamp connectors (4, 6).
5. Remove four screws (3) securing ground plate. Remove ground plate.
6. Disconnect power outlet connector (2).
7. Push grommet with harness out toward front.
8. Remove Tour-Pak lights harness.

## INSTALL

| FASTENER                    | TORQUE VALUE |             |
|-----------------------------|--------------|-------------|
| CB antenna stud nut         | 14-16 in-lbs | 1.6-1.8 N-m |
| Tour-Pak ground plate screw | 20-25 in-lbs | 2.3-2.8 N-m |

1. See Figure 8-119. Install rubber grommet on harness with split down. Position next to cable strap (1).
2. Route Tour-Pak lights harness through hole into Tour-Pak.
3. Install grommet.
4. Place harness at bottom of Tour-Pak.
5. Mate marker lamp (4, 6) and power outlet (1) connectors.
6. Install ground plate with four screws (3). Tighten.  
Torque: 20-25 in-lbs (2.3-2.8 N-m) *Tour-Pak ground plate screw*
7. Connect AM/FM antenna cable (7).
8. Install CB antenna cable (8).
  - a. Install ring terminal and flat washer onto antenna stud.
  - b. Install nut onto antenna stud.
  - c. Tighten.  
Torque: 14-16 in-lbs (1.6-1.8 N-m) *CB antenna stud nut*



- |                                    |                               |
|------------------------------------|-------------------------------|
| 1. Cable strap                     | 5. Tape                       |
| 2. Power outlet connector          | 6. Left marker lamp connector |
| 3. Ground plate/marker lamp screws | 7. Radio antenna cable        |
| 4. Right marker lamp connector     | 8. CB antenna cable           |

Figure 8-119. Tour-Pak Harness

**A WARNING**

**Be sure that all lights and switches operate properly before operating motorcycle. Low visibility of rider can result in death or serious injury. (00316a)**

1. Install Tour-Pak. See TOUR-PAK (page 3-153).
2. Install Tour-Pak liner. See TOUR-PAK (Page 3-153).
3. Install main fuse. (Page 8-8). See POWER DISCONNECT (Page 8-8).
4. Verify tail lamp, turn signal and stop lamp operation.
5. Install left side cover. See LEFT SIDE COVER (Page 3-62).
6. Install left saddlebag. See SADDLEBAGS (Page 3-161).

## PREPARE

1. Remove left saddlebag. See SADDLEBAGS (Page 3-161).
2. Remove left side cover. See LEFT SIDE COVER (Page 3-62).
3. Remove main fuse. See POWER DISCONNECT (Page 8-8).
4. Fork-mounted fairing:
  - a. Remove lamp brackets. See AUXILIARY LAMPS (Page 8-46).
  - b. Remove outer fairing and windshield. See FAIRING: FORK MOUNTED (Page 3-89).
5. Frame-mounted fairing:
  - a. Remove outer fairing and windshield. See FAIRING: FRAME MOUNTED (Page 3-100).
  - b. Remove headlamp. See HEADLAMP (Page 8-41).

## REMOVE AND INSTALL: FORK MOUNTED FAIRING

| FASTENER                            | TORQUE VALUE    |               |
|-------------------------------------|-----------------|---------------|
| Dash panel screw                    | 25-30 in-lbs    | 2.8-3.4 N-m   |
| Inner fairing to fork bracket studs | 120--180 in-lbs | 13.6-20.3 N-m |

### Remove

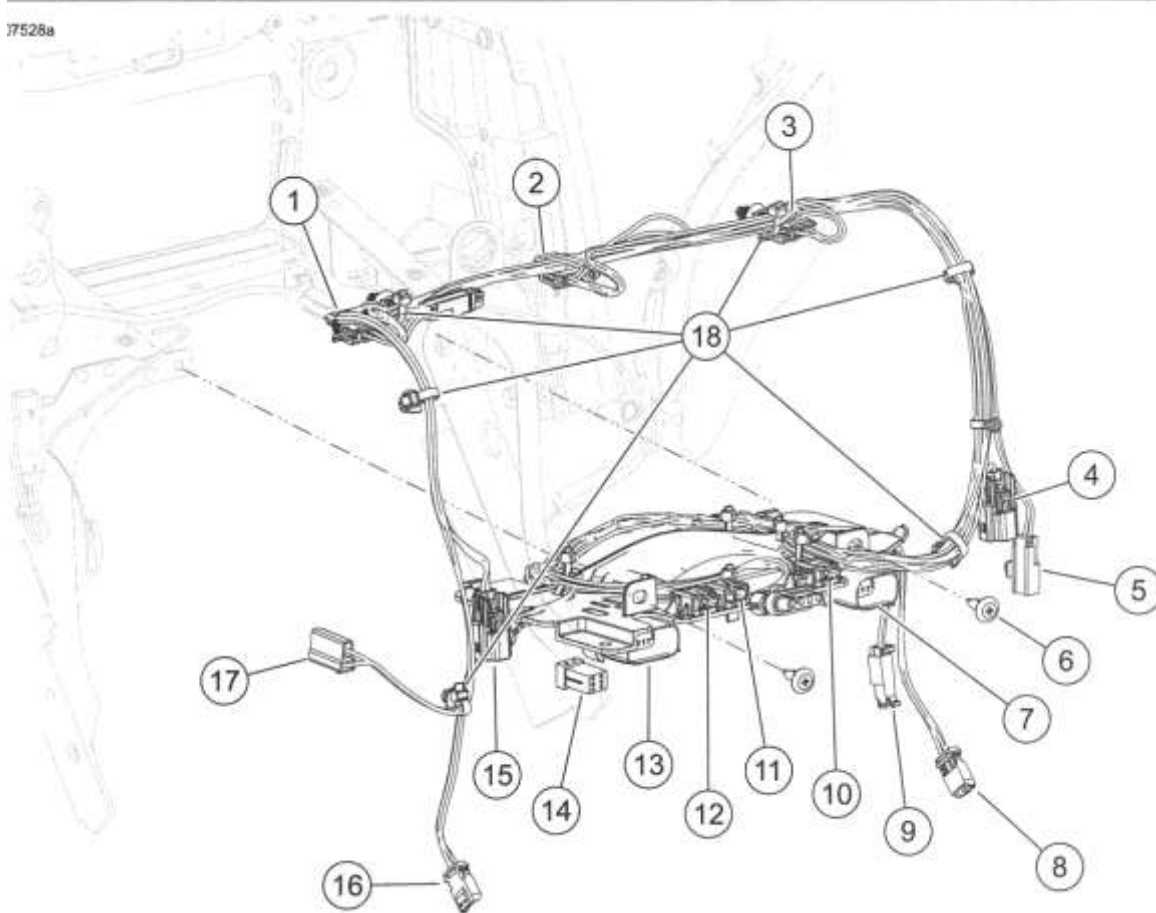
1. See Figure 8-120. Disconnect connectors (1-5). Remove from retaining devices, if present.
2. Disconnect connectors (7, 9-15, 17). Remove from retaining devices, if present.
3. Release six anchored cable straps (18) securing fairing harness.
4. Disconnect heated grips power connector (9), if equipped.

5. Remove two fasteners (6) securing electrical caddy.
6. Remove fairing harness and electrical caddy as an assembly.
7. Remove cable straps securing harness to caddy, if necessary.

### Install

1. Secure harnesses and connectors to caddy with new cable straps, if necessary.
2. Remove screws securing dash panel.
3. Remove double studs securing inner fairing to fork brackets.
4. Lift inner fairing straight up and hold.
5. While holding inner fairing up, push electrical caddy into place. Mate tabs on caddy with slots in lower fairing brackets.
6. See Figure 8-120. Secure caddy with fasteners (6).
7. Secure fairing harness with anchored cable straps (18).
8. Mate connectors (1-5). Secure to retaining devices, if present.
9. Mate connectors (7, 9-15, 17). Secure to retaining devices, if present.
10. Mate heated grips power connector (9), if equipped.
11. Install double studs securing inner fairing to fork brackets. Tighten.  
Torque: 120-180 in-lbs (13.6-20.3 N-m) *Inner fairing to fork bracket studs*
12. Install screws securing dash panel. Tighten.  
Torque: 25-30 in-lbs (2.8-3.4 N-m) *Dash panel screw*





- |   |  |
|---|--|
| 1. Voltmeter connector                                      | 10. Left handlebar switches connector        |
| 2. Instrument cluster connector                             | 11. Run/stop switch connector                |
| 3. Fuel gauge connector                                     | 12. Right handlebar switches connector       |
| 4. Left speaker connector                                   | 13. Main-to-fairing harness connector, right |
| 5. Front fender tip lamp connector                          | 14. TGS connector anchor                     |
| 6. Fastener (2)   | 15. Right speaker connector                  |
| 7. Main-to-fairing harness connector, left                  | 16. Right front lighting                     |
| 8. Left front lighting                                      | 17. Power outlet connector                   |
| 9. Auxiliary power connector (heated handgrip power: FLHTK) | 18. Anchored cable straps                    |

Figure 8-120. Inner Fairing Harness

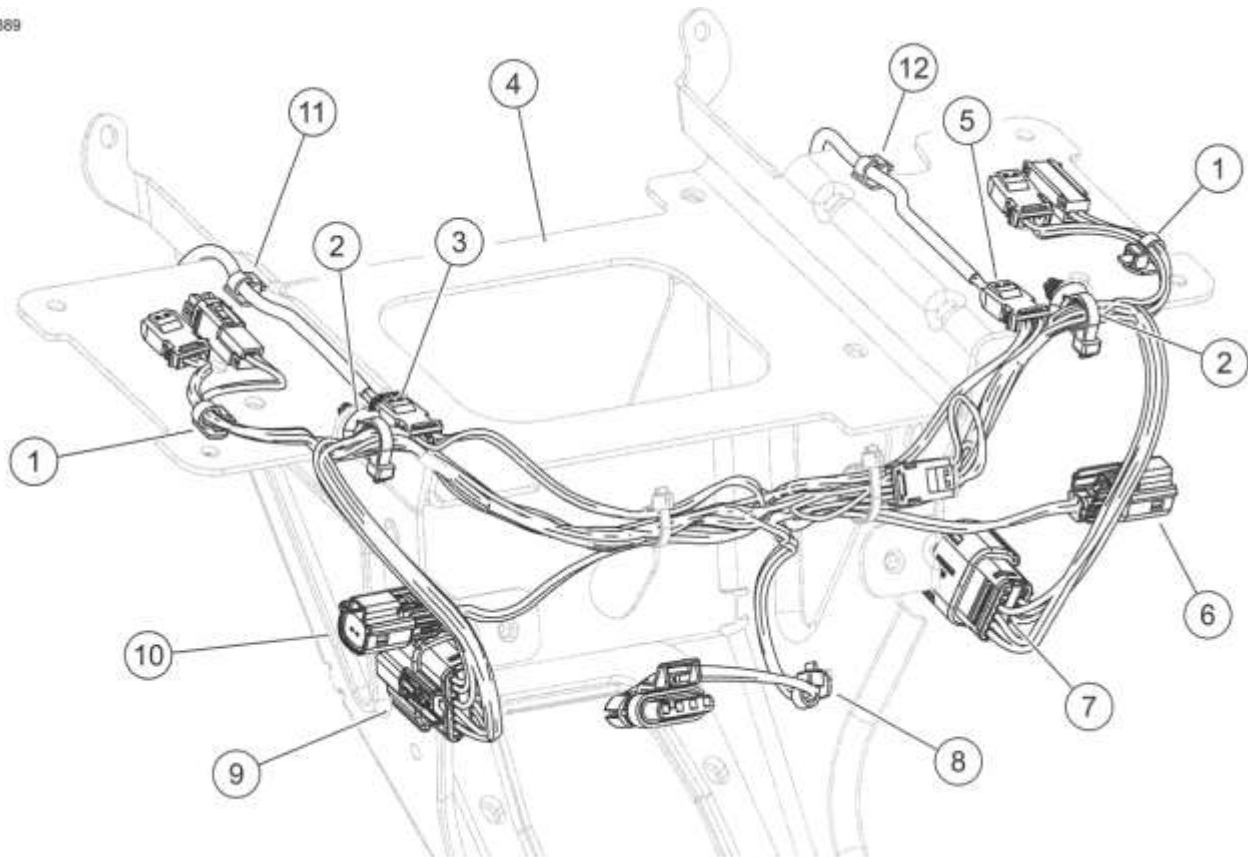
## REMOVE AND INSTALL: FRAME MOUNTED FAIRING

### Remove

- See Figure 8-121. Release left (7) and right (9) main harness connector anchors from radio support bracket. Separate connectors.
- Disconnect speaker connectors (6, 10).
- Disconnect gauge connectors (3, 5).
- Release branch harness anchors (1) from radio support bracket.
- Cut harness anchor (2) cable straps.

### Install

- See Figure 8-121. Secure fairing harness branch anchors (2) to radio support bracket.
- Mate gauge connectors (3, 5).
- Mate speaker connectors (6, 10).
- Mate main harness connectors (7, 9). Secure connector to the radio mounting bracket.
- Secure harness to harness anchors (2) with **new** cable straps.



- |   |   |
|---|---|
| <ol style="list-style-type: none"> <li>1. Turn signal branch harness anchor (2) (location stamped 2 or 4)</li> <li>2. Harness anchor (2)</li> <li>3. Voltmeter connector</li> <li>4. Radio support bracket</li> <li>5. Fuel gauge connector</li> <li>6. Left speaker connector</li> </ol> | <ol style="list-style-type: none"> <li>7. Main-to-fairing harness connector, left</li> <li>8. Headlamp harness anchor</li> <li>9. Main-to-fairing harness connector, right</li> <li>10. Right speaker connector</li> <li>11. Voltmeter jumper anchor (location stamped 1)</li> <li>12. Fuel gauge jumper anchor (location stamped 3)</li> </ol> |
|---|---|

Figure 8-121. Inner Fairing Harness: FLTR models

## COMPLETE

### 1. Frame-mounted fairing:

- a. Install headlamp. See HEADLAMP (Page 8-41).
- b. Install outer fairing and windshield. See FAIRING: FRAME MOUNTED (Page 3-100).

### 2. Fork-mounted fairing:

- a. Install outer fairing and windshield. See FAIRING: FORK MOUNTED (Page 3-89).

- b. Install lamp brackets. See AUXILIARY LAMPS (Page 8-46).
3. Install main fuse. See POWER DISCONNECT (Page 8-8).
4. Install left side cover. See LEFT SIDE COVER (Page 3-62).
5. Install left saddlebag. See SADDLEBAGS (Page 3-161).

## PREPARE

1. Purge fuel line. See PURGE FUEL LINE (Page 6-7)
2. Remove saddlebags. See SADDLEBAGS (Page 3-161)
3. Remove left side cover. See LEFT SIDE COVER (Page 3-62)
4. Remove main fuse. See POWER DISCONNECT (Page 8-8)
5. **If equipped:** Remove security siren. See SECURITY SIREN (Page 8-89)
6. Remove Body Control Module (BCM). See BODY CONTROL MODULE (BCM) (Page 8-84)
7. Remove left side caddy screws. See LEFT SIDE CADDY (Page 8-108)
8. Remove seat. See SEAT (Page 3-148)
9. Remove ECM. See ELECTRONIC CONTROL MODULE (ECM) (Page 8-83)
10. Remove battery. See INSPECT BATTERY (Page 2-48)
11. Remove fuel line from fuel tank. See FUEL LINE (Page 6-8)
12. Remove console. See CONSOLE (Page 6-5)
13. Remove fuel tank. See FUEL TANK (Page 6-10)
14. Remove right side cover. See RIGHT SIDE COVER (Page 3-63)
15. **If equipped:** Remove right side caddy screws. See RIGHT SIDE CADDY (Page 8-110)
16. Remove air cleaner cover and filter. See INSPECT AIR FILTER (Page 2-46)
17. Remove air cleaner backplate assembly. See AIR CLEANER BACKPLATE ASSEMBLY (Page 6-3)
18. Release lower backbone caddy. See LOWER BACKBONE CADDY (Page 8-112)
19. Remove starter. See STARTER (Page 8-11)
20. **Fork mounted fairing model:** See FAIRING: FORK MOUNTED (Page 3-89)
  - a. Remove outer fairing.
  - b. Remove dash panel.
21. **Frame mounted fairing model:** See FAIRING: FRAME MOUNTED (Page 3-100)
  - a. Remove outer fairing.
  - b. Remove inner fairing.
  - c. Remove instrument nacelle.
  - d. Remove fairing mounting bracket.
22. **Non-fairing model:** Remove headlamp assembly. See HEADLAMP NACELLE (Page 3-87)

**REMOVE AND INSTALL: FORK MOUNTED FAIRING****Remove***NOTE*

*Note locations of and remove cable strap anchors, wire harness anchors and cable straps as necessary.*

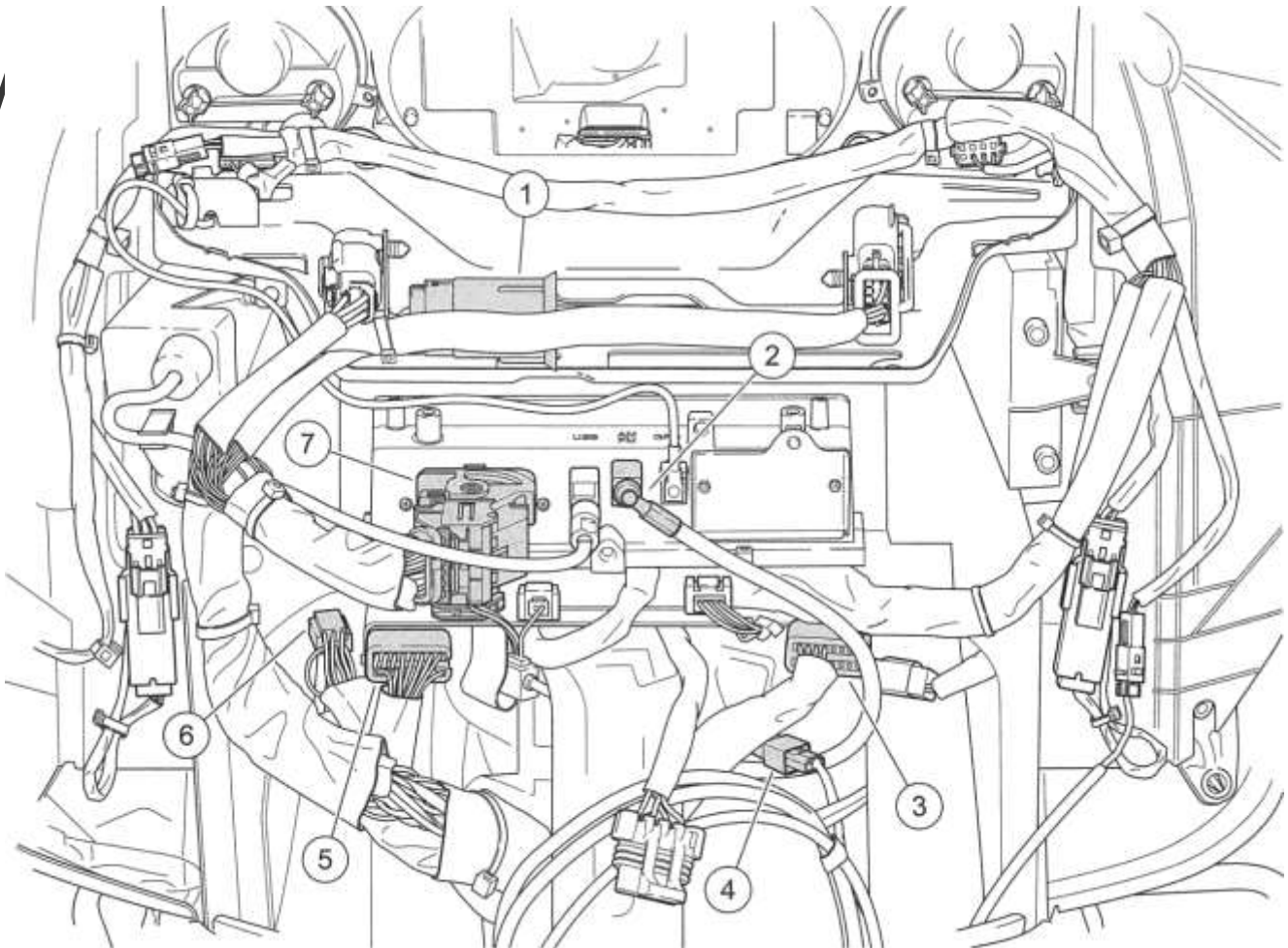
1. See Figure 8-122. **If equipped:** Disconnect electrical connectors in the fairing (1-10). Remove from retaining devices if present.
  - a. Disconnect Citizens Band (CB) module (1).
  - b. Disconnect P&A audio (2).
  - c. Disconnect AM/FM radio antenna (3).
  - d. Disconnect CB radio antenna (4).
  - e. Disconnect left main-to-fairing harness (5).
  - f. Disconnect fork bracket ground wire (6).
  - g. Disconnect right main-to-fairing harness (7).
  - h. Disconnect Twist Grip Sensor (TGS) (8).
  - i. Disconnect radio (9).
2. Disconnect ignition switch connector.
3. Pull dash panel switch and ignition switch harnesses forward into fairing area.
4. See Figure 8-123. Disconnect WSS connector (2).
5. Release brake line retainer (1).
6. See Figure 8-124. Remove steering head caddy.
  - a. Loosen retainer screw.
  - b. Pull retainer securing each steering head caddy.
  - c. Remove both caddies from steering head.

7. Pull main harnesses rearward and allow to hang.

To complete the remove procedure go to Remove and Install: Common Components (Page 8-123)

## Install

1. Route main harness forward along each side of steering head and into inner fairing area.
2. See Figure 8-124. Secure steering head caddies with retainer.
3. See Figure 8-123. Connect electrical connector/retainer in the right side steering head caddy area.
  - a. Secure brake lines to retainer (1).
  - b. Connect front WSS (2).
4. See Figure 8-122. **If equipped:** Connect electrical connectors in the fairing (1-10). Secure to anchors if present.
  - a. Connect radio (9).
5. Route dash panel and ignition switch connectors back between handlebar and upper fork bracket.
6. Connect ignition switch connector.
  - b. Connect TGS (8).
  - c. Connect right main-to-fairing harness (7).
  - d. Connect fork bracket ground wire (6).
  - e. Connect left main-to-fairing harness (5).
  - f. Connect CB radio antenna (4).
  - g. Connect AM/FM radio antenna (3).
  - h. Connect P&A audio (2).
  - i. Connect CB module (1).



- |                                 |                                  |
|---------------------------------|----------------------------------|
| 1. P&A audio                    | 5. Right main-to-fairing harness |
| 2. AM/FM radio antenna          | 6. TGS                           |
| 3. Left main-to-fairing harness | 7. Radio                         |
| 4. Fork bracket ground wire     |                                  |

Figure 8-122. Main Harness Fairing Connectors (typical)

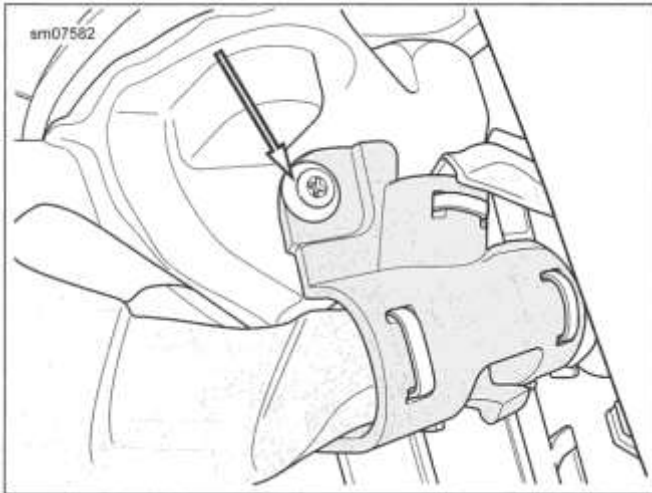
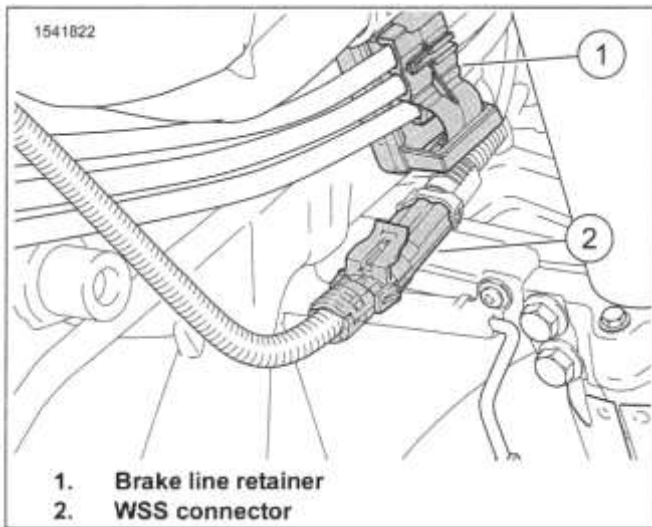


Figure 8-124. Steering Head Caddy (right side shown)

## REMOVE AND INSTALL: FRAME MOUNTED FAIRING

### Remove

1. **NOTE**  
*Note locations of and remove cable strap anchors, wire harness anchors and cable straps as necessary.*

See Figure 8-125. Disconnect electrical connectors around nacelle (1-4, 6-10). Remove retainer securing the left branch from nacelle caddy.

- a. Disconnect ground (1).
- b. Disconnect TGS (2).
- c. Disconnect LHCM (3).
- d. Disconnect RHCM (4).
- e. Disconnect right accessory switch module (6).
- f. **If equipped:** Disconnect WSS (7).
- g. Disconnect Ambient Air Temperature (MT) (8).
- h. Disconnect ignition switch (9).

Disconnect left accessory switch module (10).

Pull main harness branches rearward and allow to hang.

To complete the remove procedure go to Remove and Install: Common Components (Page 8-123)

### Install

Remove the retainer securing the left branch from the **new** nacelle caddy.

Route main harness forward along each side of steering head and into inner fairing area.

**NOTE**

*The branch with the nacelle caddy attached goes on the right side.*

See Figure 8-125. Route both harness branches up between brake lines and steering head.

Secure the left branch to the nacelle caddy.

Route accessory switch (6, 10) and ignition switch (9) connectors back between handlebar and upper fork bracket.

Connect electrical connectors in the nacelle area (1-4, 6-10).

Connect left accessory switch module (10).

Connect ignition switch (9).

Connect MT (8).

**If equipped:** Connect WSS (7).

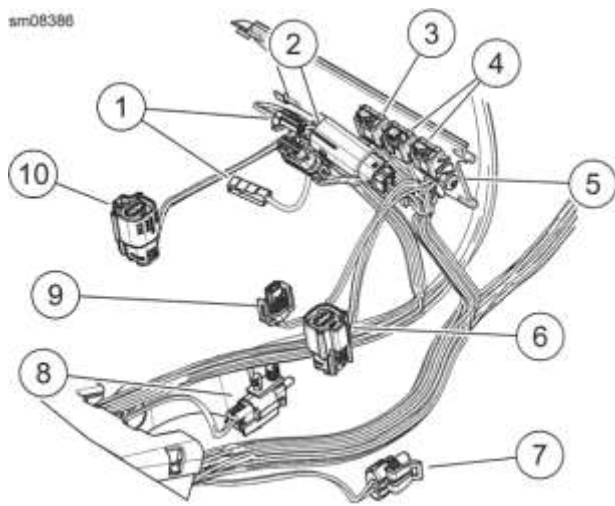
Connect right accessory switch module (6).

Connect RHCM (4).

Connect LHCM (3).

Connect TGS (2).

Connect ground (1).



1. Ground
2. TGS
3. LHCM
4. RHCM
5. Nacelle caddy
6. Right accessory switch module
7. WSS
8. AAT sensor
9. Ignition switch
10. Left accessory switch module

Figure 8-125. Nacelle Connectors

## REMOVE AND INSTALL: WITHOUT FAIRING

### Remove

#### 1. *NOTE*

Note locations of and remove cable strap anchors, wire harness anchors and cable straps as necessary.

See Figure 8-126. Disconnect electrical connectors around left steering head caddy (1-4).

Disconnect LHCM (1).

Disconnect TGS (2).

Disconnect Right auxiliary/fog/turn signal lamps (3).

Disconnect Left auxiliary/fog/turn signal lamps (4).

2. Disconnect ground wire leading to left upper fork bracket.

3. See Figure 8-127. Disconnect electrical connectors around right steering head caddy (1, 2). Leave main harness connectors secured to caddy.

Disconnect RHCM (1).

**If equipped:** Disconnect WSS (2).

To complete the remove procedure go to Remove and Install: Common Components (Page 8-123)

### Install

1. Route front right section of main harness forward along right side of steering head and into headlamp nacelle.

See Figure 8-127. Connect electrical connectors/retainer in the right steering head caddy area (1, 2, 5).

Secure steering head caddy with retainer (5).

**If equipped:** Connect front WSS (2).

Connect RHCM (1).

Route front left section of main harness forward along left side of steering head and into headlamp nacelle.

See Figure 8-126. Connect electrical connectors/retainer in the left steering head caddy area (1-5).

Secure steering head caddy with retainer (5).

Connect left auxiliary/fog/turn signal lamps (4).

Connect right auxiliary/fog/turn signal lamps (3).

Connect TGS (2).

e. Connect LHCM (1).

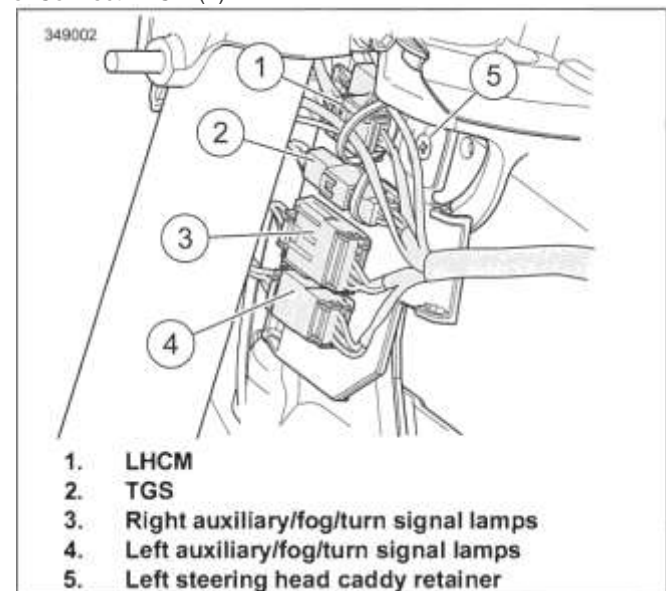


Figure 8-126. Left Steering Head Caddy Connectors

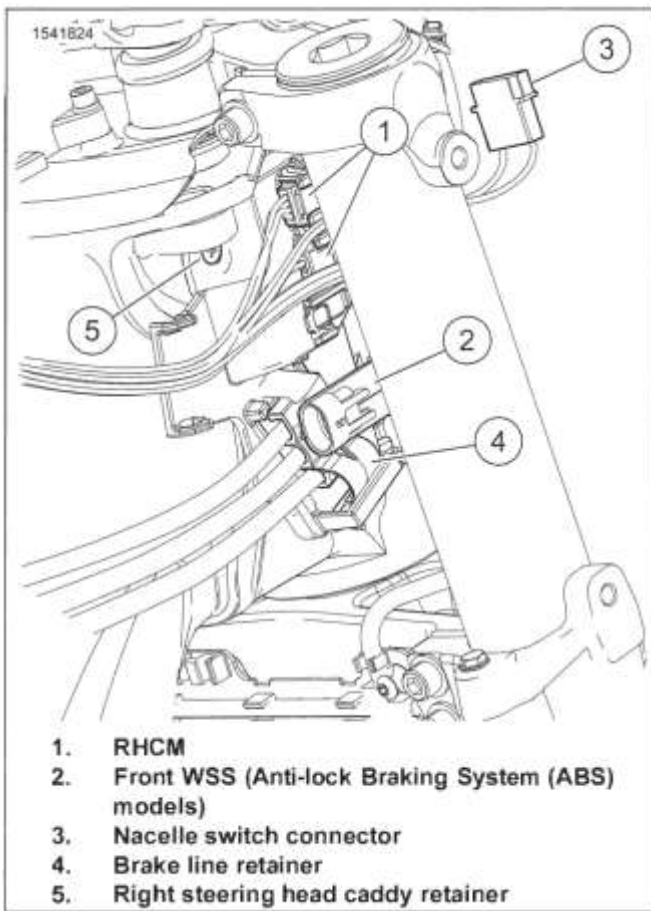


Figure 8-127. Right Steering Head Caddy

## REMOVE AND INSTALL: COMMON COMPONENTS

| FASTENER                       | TORQUE VALUE |              |
|--------------------------------|--------------|--------------|
| Harness ground stud flange nut | 50-90 in-lbs | 5.7-10.2 N-m |

### Remove

1. *NOTE*  
*Note locations of and remove cable strap anchors, wire harness anchors and cable straps as necessary*

See Figure 8-128. Disconnect electrical connectors around upper engine (3-10, 12-14).

Disconnect rear KS (3).

Disconnect rear ACR (4).

Disconnect rear fuel injector (5).

Disconnect horn (6, 7).

Disconnect Throttle Control Actuator (TCA) (8).

Disconnect Temperature, Intake Air / Manifold Absolute Pressure (TMAP) (9).

Disconnect front fuel injector (10).

Disconnect ET (12).

Disconnect front ACR (13).

Disconnect front KS (14).

Draw harnesses to right side.

**ABS models:** Release brake lines from wire trough.

Remove harness from left upper frame rails.

**FLHT models:** See Figure 8-129. Disconnect electrical connectors/ring terminals under seat area (3-6, 12).

Disconnect security antenna (3).

Disconnect purge solenoid (4).

Remove left side ground stud (5).

*NOTE*

*Record harness ground ring terminal orientation when removing.*

Remove right side ground stud (6).

Disconnect rear lighting (7).

**FLHR models:** See Figure 8-130. Disconnect electrical connectors/ring terminals under seat area (1, 3-6).

Disconnect rear lighting (1).

Disconnect security antenna (3).

Disconnect purge solenoid (4).

Remove left side ground stud (5).

*NOTE*

*Record harness ground ring terminal orientation when removing.*

Remove right side ground stud (6).

**FLHX, FLT models:** See Figure 8-131. Disconnect electrical connectors/ring terminals under seat area (1, 3-6).

Disconnect rear lighting (1).

Disconnect security antenna (3).

Disconnect purge solenoid (4).

Remove left side ground stud (5).

*NOTE*

*Record harness ground ring terminal orientation when removing.*

Remove right side ground stud (6).

Detach wire harness form holes in frame backbone.

**Tour-Pak models:** See Figure 8-137. **If equipped:**

Disconnect electrical connectors around Tour-Pak (5, 6, 9, 10).

Disconnect CB antenna (5).

Disconnect rear audio (6).

Disconnect AM/FM antenna (9).

Disconnect Tour-Pak lighting (10).

See Figure 8-132. **If equipped:** Disconnect electrical connectors under right side cover (1,3-9).

Disconnect cooling fan (1).

Disconnect rear WSS (3).

Disconnect rear HO2S (4).

Disconnect front HO2S (5).

Disconnect ABS Electronic Control Unit (ECU) (6).

Disconnect P&A accessory (7).

Disconnect Inertial Measurement Unit (IMU) (8).

Disconnect ignition coil (9).

Draw harness branch into battery tray.

See Figure 8-133. Draw out battery to starter solenoid cable (1) through opening at rear of left side caddy.

Disconnect electrical connectors around starter area (3-5).

Disconnect neutral switch 1 (3).

Disconnect neutral switch 2 (4).

Draw harness branch into battery tray.

**Twin-Cooled:** Remove pump cover.

**Air-cooled:** Remove lower electrical cover.

See Figure 8-134. **If equipped:** Disconnect electrical connectors around front of engine area (4-12).

Disconnect cooling pump (4).

Disconnect left cooling jumper (5).

Disconnect Crankshaft Position (CKP)sensor (6).

Disconnect Jiffy Stand Sensor (JSS) (7).

**Police, Trike models:** Disconnect oil cooling fan (8).

Disconnect right cooling jumper (9).

Disconnect voltage regulator (10).

Disconnect rear brake switch (11).

Disconnect oil pressure sender (12).

Free main harness from two conduit clips anchored to lower-right frame tube.

Remove main harness.

Pull up harness branch through battery tray.

While pulling left side caddy away from motorcycle, feed wire trough and harnesses out through opening.

## Install

Position harness into frame.

Feed front end of wire trough in through opening between left frame downtubes.

Pull up and out through opening at top of battery tray

Lay wire trough on top of frame backbone.

Push anchor pins at rear of wire trough into holes in frame backbone.

See Figure 8-134. Route front of engine branch.

Locate the lower front branch terminating with voltage regulator and other seen in graphic.

Route down inside of the mid downtube and to the front following the lower frame tube.

See Figure 8-133. Route starter area branch.

Locate branch seen in graphic.

Route down through opening right of ignition coil to top of transmission.

See Figure 8-132. Route right side cover area branch.

Locate branch terminating with HO2S and other seen in graphic.

Route down to area of right caddy.

**Tour-Pak models:** See Figure 8-137. Route Tour-Pak area branch.

Locate branch terminating in the Tour-Pak lights and other seen in graphic.

Route along left upper frame tube to area near Tour-Pak.

Route starter power cable and ignition coil connector down through opening left of ignition coil.

Route rear fender lights connector through opening at rear of battery tray and up through frame crossmember.

FLHX, FLT models: See Figure 8-131. Connect electrical connectors/ring terminals under seat area (1,3-6).

Install right side ground stud (6). Secure loosely with nut.

### NOTE

*Position harness ground ring terminal to per-recorded orientation records.*



Install left side ground stud (5). Secure loosely with nut.

Connect purge solenoid (4).

Connect security antenna (3).

Connect rear lighting (1).

FLHR models: See Figure 8-130. Connect electrical connectors/ring terminals under seat area (1,3-6).

- a. Install right side ground stud (6). Secure loosely with nut.

**NOTE**

*Position harness ground ring terminal to per-recorded orientation records.*

- b. Install left side ground stud (5). Secure loosely with nut.
- c. Connect purge solenoid (4).
- d. Connect security antenna (3).
- e. Connect rear lighting (1).

FLHT models: See Figure 8-129. Connect electrical connectors/ring terminals in the under seat area (3-6, 12).

Connect rear lighting (7).

Install right side ground stud (6). Secure loosely with nut.

**NOTE**

*Position harness ground ring terminal to per-recorded orientation records.*

Install left side ground stud (5). Secure loosely with nut.

Connect purge solenoid (4).

Connect security antenna (3).

Tighten ground stud flange nuts.

Torque: 50-90 in-lbs (5.7-10.2 N-m) *Harness ground stud flange nut*

See Figure 8-133. Connect electrical connectors in the starter area (3-5).

Connect neutral switch 2 (4).

Connect neutral switch 1 (3).

Install ignition coil connector.

See Figure 8-134. Route lower front of engine branch inboard of front engine mounting bracket.

Twin-Cooled:

- a. Route cooling pump (4), left fan jumper and right fan jumper (9) under the front engine mount.

Air-cooled:

- a. Route oil cooling fan (8) under the front engine mount.

Secure harness to frame crossmember with new anchored cable strap.

If equipped: Connect electrical connectors in the front of engine area (4-12).

Connect oil pressure sender (12).

Connect rear brake switch (11).

Connect voltage regulator (10).

Connect right cooling jumper (9). Secure to anchors.

Police, Trike models: Connect oil cooling fan (8). Secure to anchors.

Connect JSS (7). Secure to T-stud on front caddy.

Connect CKP (6). Push anchor on connector into hole in front caddy.

Connect left cooling jumper (5).

Connect cooling pump (4). Secure to anchors.

Secure the regulator harness and JSS harness to the frame with a new cable strap.

Air-cooled: Install protective cover to frame with new retainers.

See Figure 8-138. Secure lower front branch to mid-frame downtube with new cable strap (3).

Secure horizontal portion along lower frame in conduit clips (2).

- a. See Figure 8-136. Verify that rear brake line (1) and HO2 sensor wire (2) are secured in retainers on conduit clips.

See Figure 8-132. If equipped: Connect electrical connectors in the right side cover area (1,3-9).

Connect ignition coil (9).

Connect IMU (8).

Connect P&A accessory (7).

Connect ABS ECU (6).

Connect front HO2S (5). Secure connector to anchor on right caddy.

Connect rear HO2S (4). Secure connector to anchor on right caddy.

Connect WSS (3).

Connect cooling fan (1).

Secure harnesses to left upper frame tube with two new cable straps.

See Figure 8-139. Secure brake lines to wire trough including the central anchor block.

See Figure 8-135. Route brake lines through the retainers (2).

See Figure 8-128. Connect electrical connectors in the upper engine area (3-10, 12-14).

Connect front KS (14).

Connect ACR (13).

Connect ET (12).

Connect gray connector front fuel injector (10).

Connect TMAP (9). Engage yellow lock.

Connect TCA (8). Install **new** anchored cable strap in hole at front right side of induction module.

Route the horn branch to the left side of the engine and under the horn bracket. Route the branch under coolant lines.

Connect horn (6, 7). Capture conduit in J-clamp. Secure to horn bracket with two cable straps.

Connect black connector rear fuel injector (5).

Connect rear ACR (4).

Connect rear KS (3).

**Tour-Pak models:** Connect electrical connectors in the upper engine area (5, 6, 9, 10).

Connect Tour-Pak lighting (10).

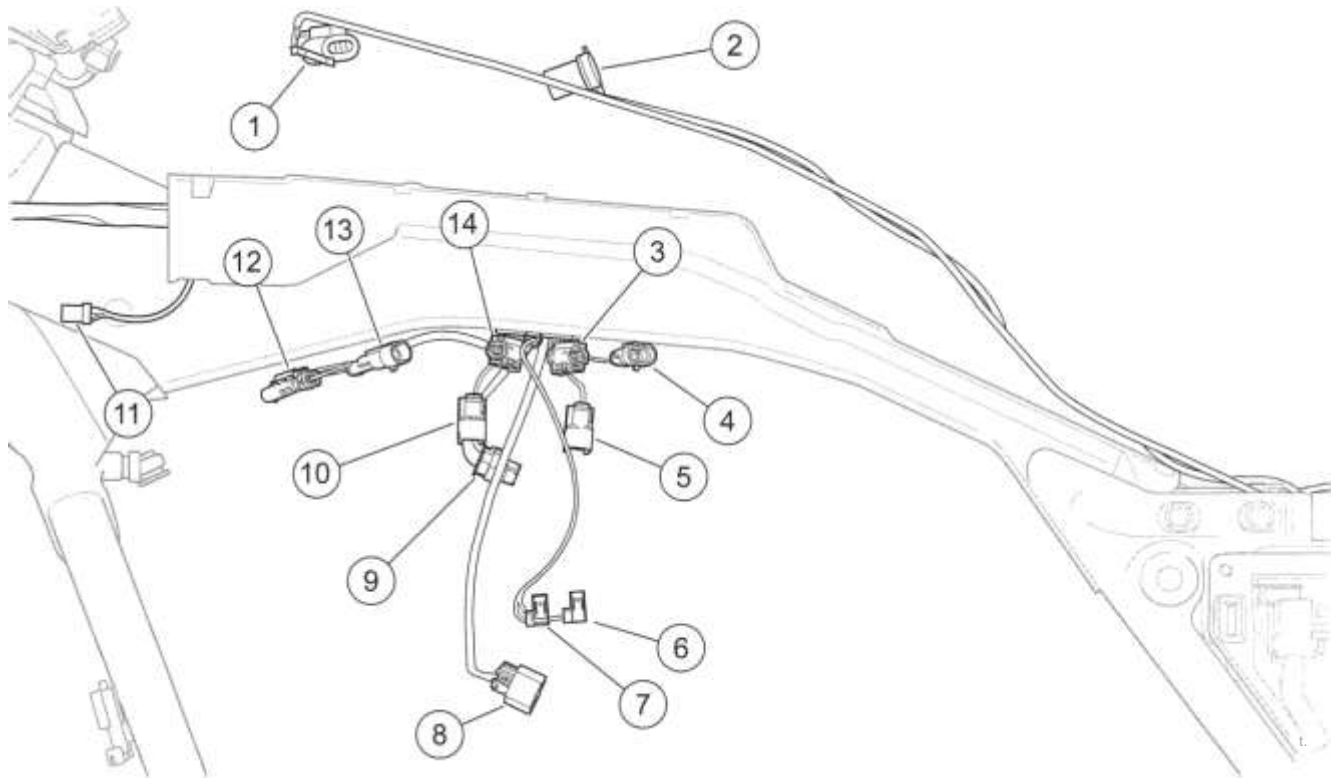
Connect AM/FM antenna (9).

Connect rear audio (6).

**If equipped:** See Figure 8-137. Connect CB antenna

Depending upon model, continue with install procedure at:

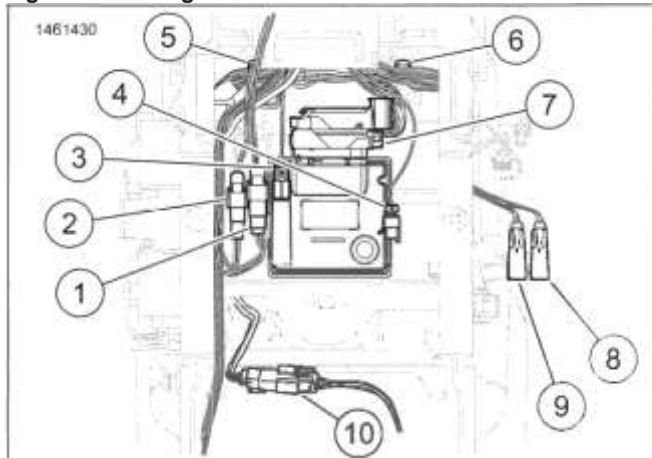
- Remove and Install: Fork Mounted Fairing (Page 8-119)
- Remove and Install: Frame Mounted Fairing (Page 8-121)
- Remove and Install: Without Fairing (Page 8-122)



- 1. Fuel pump and level sensor connector
- 2. Rider headset connector (FLHTK)
- 3. Rear KS connector
- 4. Rear ACR connector
- 5. Rear fuel injector connector
- 6. Horn connector
- 7. Horn connector

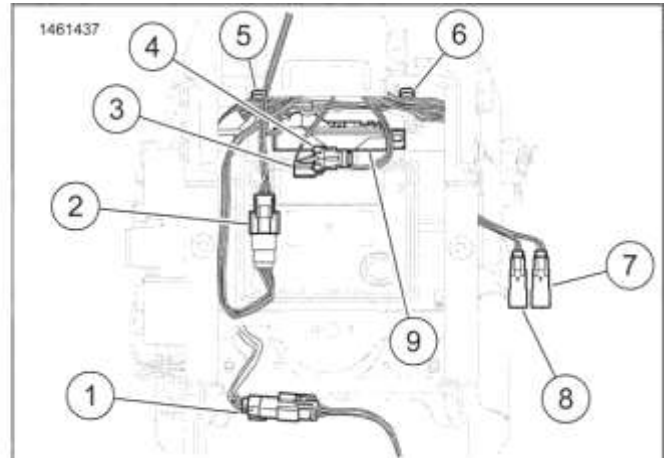
- 8. TCA connector
- 9. TMAP connector
- 11. Front fuel injector connector
- 12. Fuel gauge connector (without fairing)
- 13. ET sensor connector
- 14. Front ACR connector
- 14. Front KS connector

Figure 8-128. Engine



- 1. Fuel tank harness [13]
- 2. Rider headset [53]
- 3. Security antenna [209]
- 4. Purge solenoid [95]
- 5. Left side ground stud [GND2] [GND2A]
- 6. Right side ground stud [GND1]
- 7. ECM [78]
- 8. Pre catalyst rear HO2S [138]
- 9. Pre catalyst front HO2S [137]
- 10. Rear harness [7]

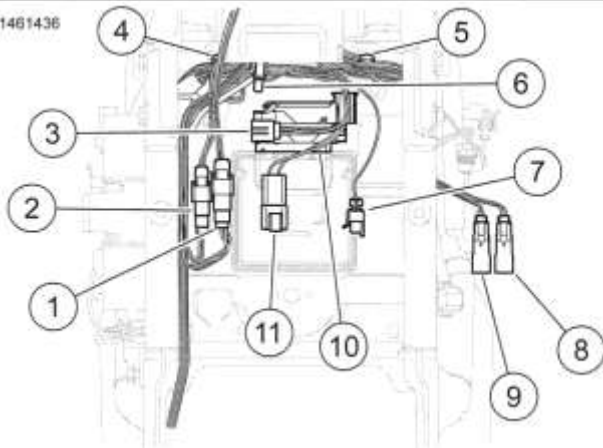
Figure 8-129. Under Seat: FLHT



- 1. Rear lighting [7]
- 2. Console harness [20]
- 3. Security antenna [209]
- 4. Purge solenoid [95]
- 5. Left side ground stud [GND2] [GND2A]
- 6. Right side ground stud [GND1]
- 7. Rear HO2S [138]
- 8. Front HO2S [137]
- 9. ECM [78]

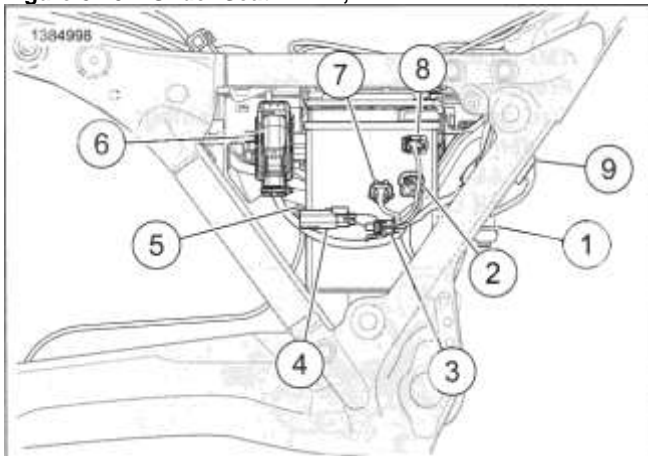
Figure 8-130. Under Seat: FLHR

1461436



- Rear lighting [7]
- Fuel tank harness [13]
- Security antenna [209]
- Purge solenoid [95]
- Left side ground stud [GND2] [GND2A]
- Right side ground stud [GND1]
- AM/FM antenna [52]
- HO2S bank 2 sensor 1 [138]
- HO2S bank 1 sensor 1 [137]
- ECM [78]

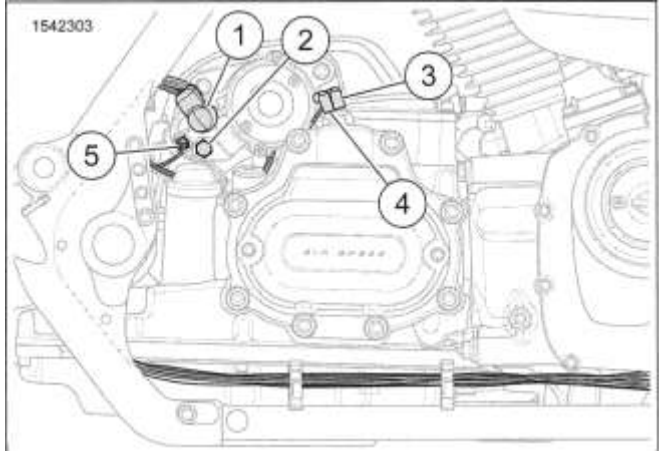
Figure 8-131. Under Seat: FLHX, FLT



- Chassis cooling fan
- Terminating resistor
- RearWSS
- Rear HO2S
- Front HO2S
- ABS ECU
- P&A accessory
- IMU
- Ignition coil

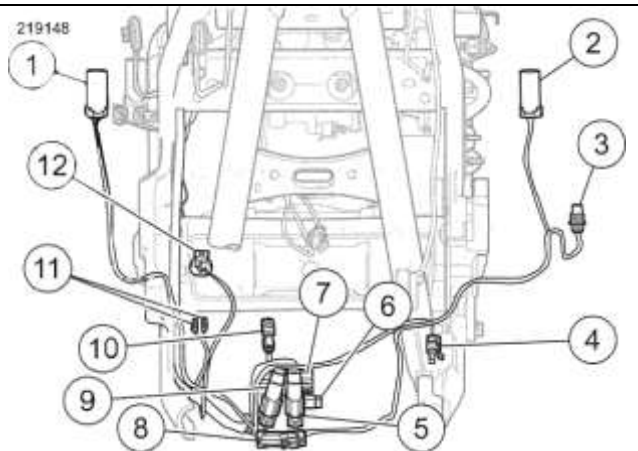
Figure 8-132. Right Side Cover Area

1542303



- 1. Battery terminal of starter solenoid
- 2. Starter terminal of starter solenoid
- 3. Neutral switch -1
- 4. Neutral switch -2
- 5. Starter solenoid

Figure 8-133. Starter Area



- Right cooling fan
- Left cooling fan
- Engine Coolant Temperature (ECT) sensor
- Cooling pump
- Left cooling jumper
- CKP sensor
- JSS
- Oil cooling fan
- Right cooling jumper
- Voltage regulator
- Rear brake switch
- Oil pressure sender

Figure 8-134. Front of Engine Area

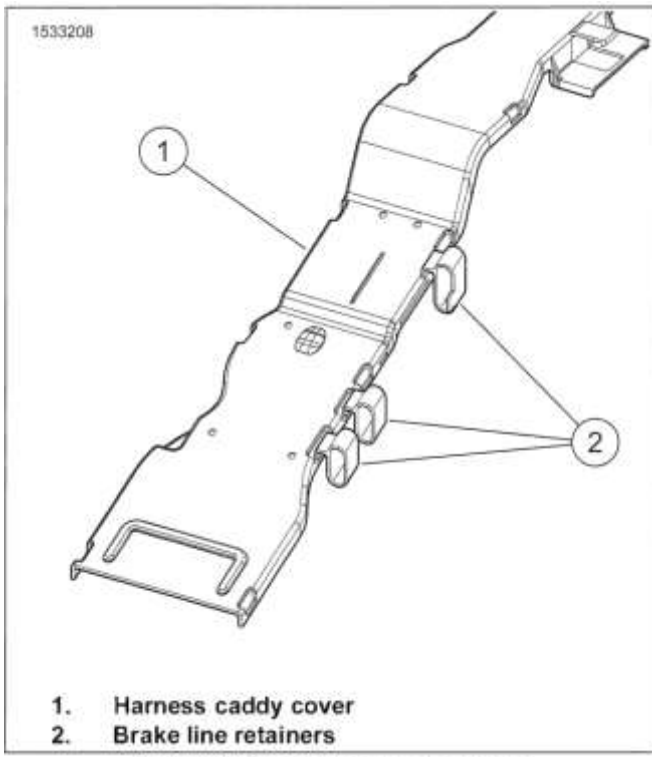


Figure 8-135. Brake Line Retainer

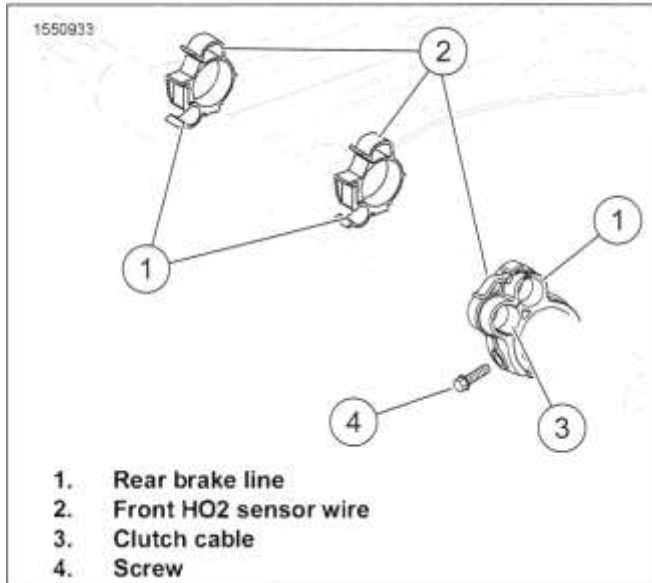
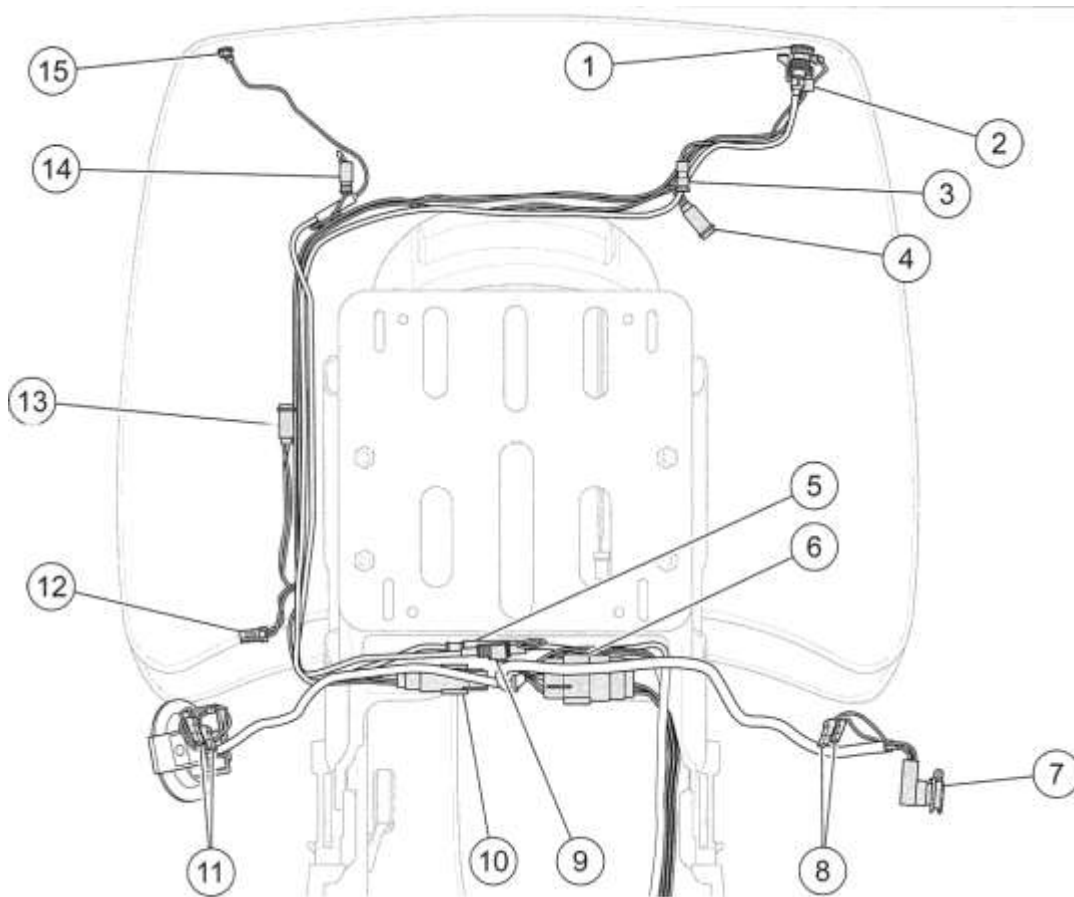


Figure 8-136. Lower Frame Rail Line and Harness Retainers



1. AM/FM antenna
2. Tour-Pak lights
3. AM/FM antenna ground
4. Left side marker lights
5. CB antenna
6. Rear audio
7. Passenger headset
8. Left rear speaker

9. AM/FM antenna
10. Tour-Pak lights
11. Right rear speaker
12. Power outlet
13. Right side marker lights
14. CB antenna ground
15. CB antenna

Figure 8-137. Tour-Pak Models

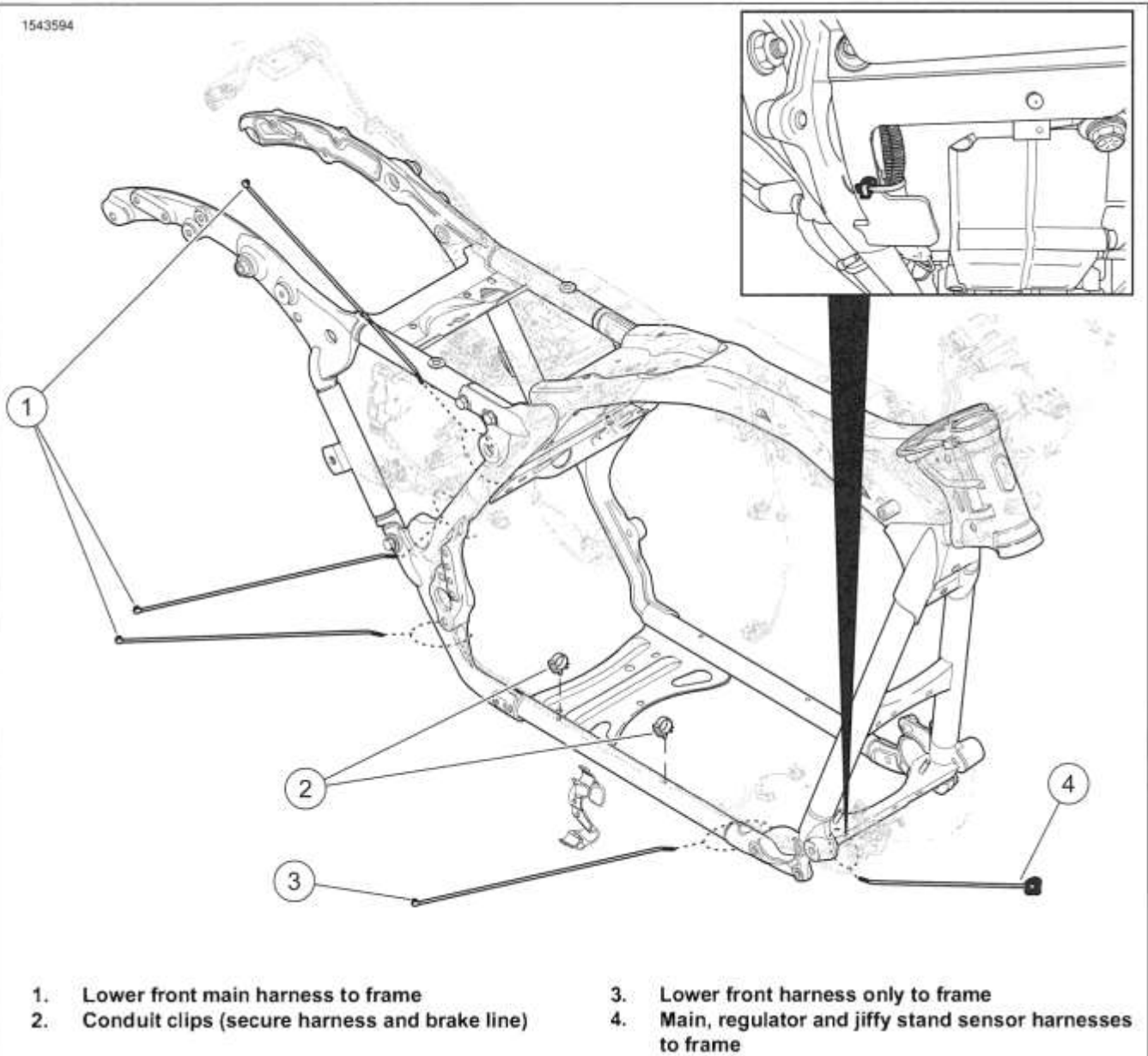
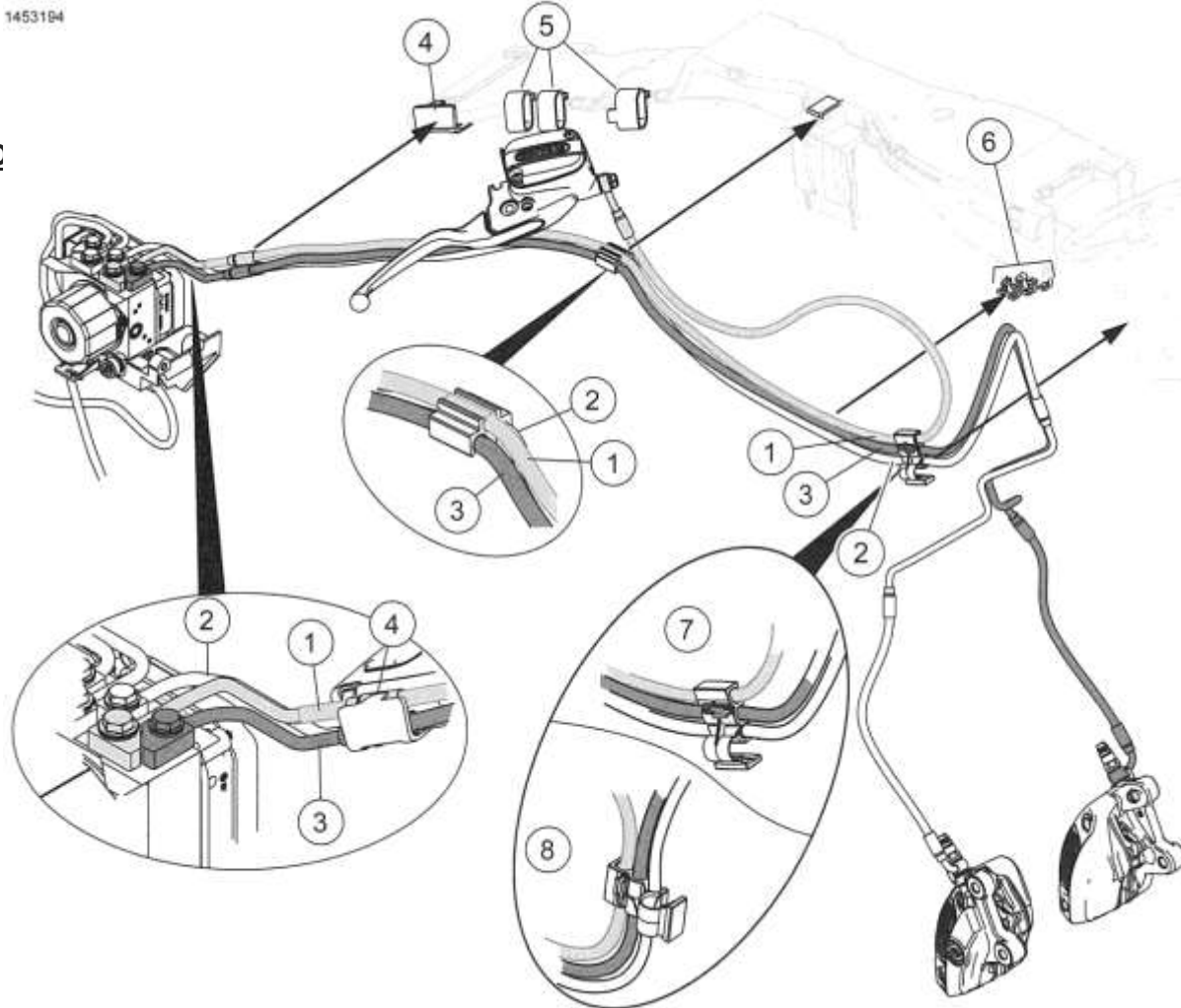


Figure 8-138. Lower Front Harness Cable Strap Locations

**CC****Figure 8-139. Front ABS Brake Line Routing**

5. Install lower backbone caddy. See LOWER BACKBONE CADDY (Page 8-112)

**Non-fairing model:** Install headlamp assembly. See HEADLAMP NACELLE (Page 3-87)

**Frame mounted fairing model:** See FAIRING: FRAME MOUNTED (Page 3-100)

Install fairing mounting bracket.

Install instrument nacelle.

Install inner fairing.

Install outer fairing.

**Fork mounted fairing model:** See FAIRING: FORK MOUNTED (Page 3-89)

Install dash panel.

Install outer fairing.

Install starter. See STARTER (Page 8-11)

6. Install air cleaner backplate assembly. See AIR CLEANER BACKPLATE ASSEMBLY (Page 6-3)

7. Install air cleaner cover and filter. See INSPECT AIR FILTER (Page 2-46)

8. **If removed:** Install right side caddy screws. See RIGHT SIDE CADDY (Page 8-110)

9. Install right side cover. See RIGHT SIDE COVER (Page 3-63)

10. Install fuel tank. See FUEL TANK (Page 6-10)

11. Install console. See CONSOLE (Page 6-5)

12. Install fuel line on fuel tank. See FUEL LINE (Page 6-8)

13. Install battery. See INSPECT BATTERY (Page 2-48)



14. Install ECM. See ELECTRONIC CONTROL MODULE (ECM) (Page 8-83)
15. Install seat. See SEAT (Page 3-148)
16. Install left side caddy screws. See LEFT SIDE CADDY (Page 8-108)
17. Install BCM. See BODY CONTROL MODULE (BCM) (Page 8-84)
18. **If removed:** Install security siren. See SECURITY SIREN (Page 8-89)
19. Install main fuse. See POWER DISCONNECT (Page 8-8)
20. Install left side cover. See LEFT SIDE COVER (Page 3-62)
21. Install saddlebags. See SADDLEBAGS (Page 3-161)



## NOTES

| <b>SUBJECT</b>                   | <b>PAGE NO.</b> |
|----------------------------------|-----------------|
| A.1 WIRING DIAGRAMS .....        | A-1             |
| A.2 WIRE HARNESS CONNECTORS..... | A-63            |

## NOTES



## GENERAL

### Wire Color Codes

Wire traces on wiring diagrams are labeled with alpha codes. Refer to Table A-1.

**For Solid Color Wires:** See Figure A-1. The alpha code identifies wire color.

**For Striped Wires:** The code is written with a slash (/) between the solid color code and the stripe code. For example, a trace labeled GN/Y is a green wire with a yellow stripe.

### Wiring Diagram Symbols

See Figure A-1. On wiring diagrams and in service/repair instructions, connectors are identified by a number in brackets []. The letter inside the brackets identifies whether the housing is a socket or pin housing.

**A=Pin:** The letter A and the pin symbol after a connector number identifies the pin side of the terminal connectors.

**B=Socket:** The letter B and the socket symbol after a connector number identifies the socket side of the terminal connectors. Other symbols found on the wiring diagrams include the following:

**Diode:** The diode allows current flow in one direction only in a circuit.

**Wire break:** The wire breaks are used to show option variances or page breaks.

**No Connection:** Two wires crossing over each other in a wiring diagram that are shown with no splice indicating they are not connected together.

**Circuit to/from:** This symbol indicates a more complete circuit diagram on another page. The symbol is also identifying the direction of current flow.

**Splice:** Splices are where two or more wires are connected together along a wiring diagram. The indication of a splice only indicates that wires are spliced to that circuit. It is not the true location of the splice in the wiring harness.

**Ground:** Grounds can be classified as either clean or dirty grounds. Clean grounds are identified by a (BK/GN) wire and are normally used for sensors or modules.

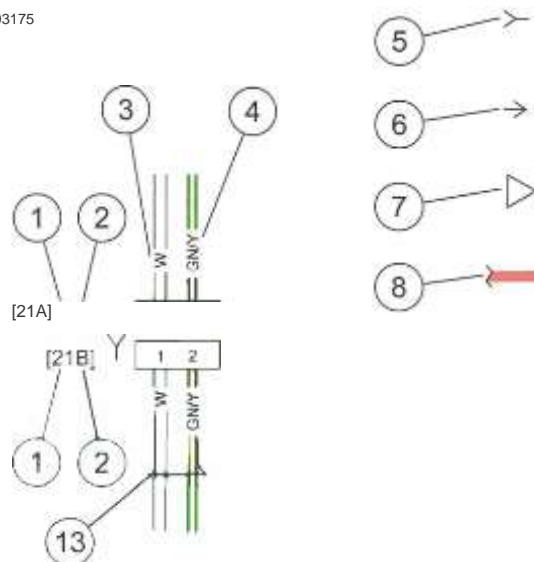
#### NOTE

*Clean grounds usually do not have electric motors, coils or anything that may cause electrical interference on the ground circuit.*

Dirty grounds are identified by a (BK) wire and are used for components that are not as sensitive to electrical interference.

**Twisted pair:** This symbol indicates the two wires are twisted together in the harness. This minimizes the circuit's electromagnetic interference from external sources. If repairs are necessary to these wires they should remain as twisted wires.

ed03175



- Connector number
  - Terminal code (A=pin, B=socket)
  - Solid wire color
  - Striped wire color
  - Socket symbol
  - Pin symbol
  - Diode
  - Wire break
  - No connection
  - Circuit to/from
  - Splice
  - Ground
  - Twisted pair
- Figure A-1. Connector/Wiring Diagram Symbols



- System power
- Battery
- Spare/fork lock (if equipped)
- Spare
- Spare
- Cooling relay
- P&A relay
- Radio
- P&A
- Cooling

Figure A-2. Fuse Block [64B]

Table A-1. Wire Color Codes

| ALPHA CODE | WIRE COLOR  |
|------------|-------------|
| BE         | Blue        |
| BK         | Black       |
| BN         | Brown       |
| GN         | Green       |
| GY         | Gray        |
| LBE        | Light Blue  |
| LGN        | Light Green |
| o          | Orange      |
| PK         | Pink        |
| R          | Red         |
| TN         | Tan         |
| V          | Violet      |
| W          | White       |
| Y          | Yellow      |

**WIRING DIAGRAMS**

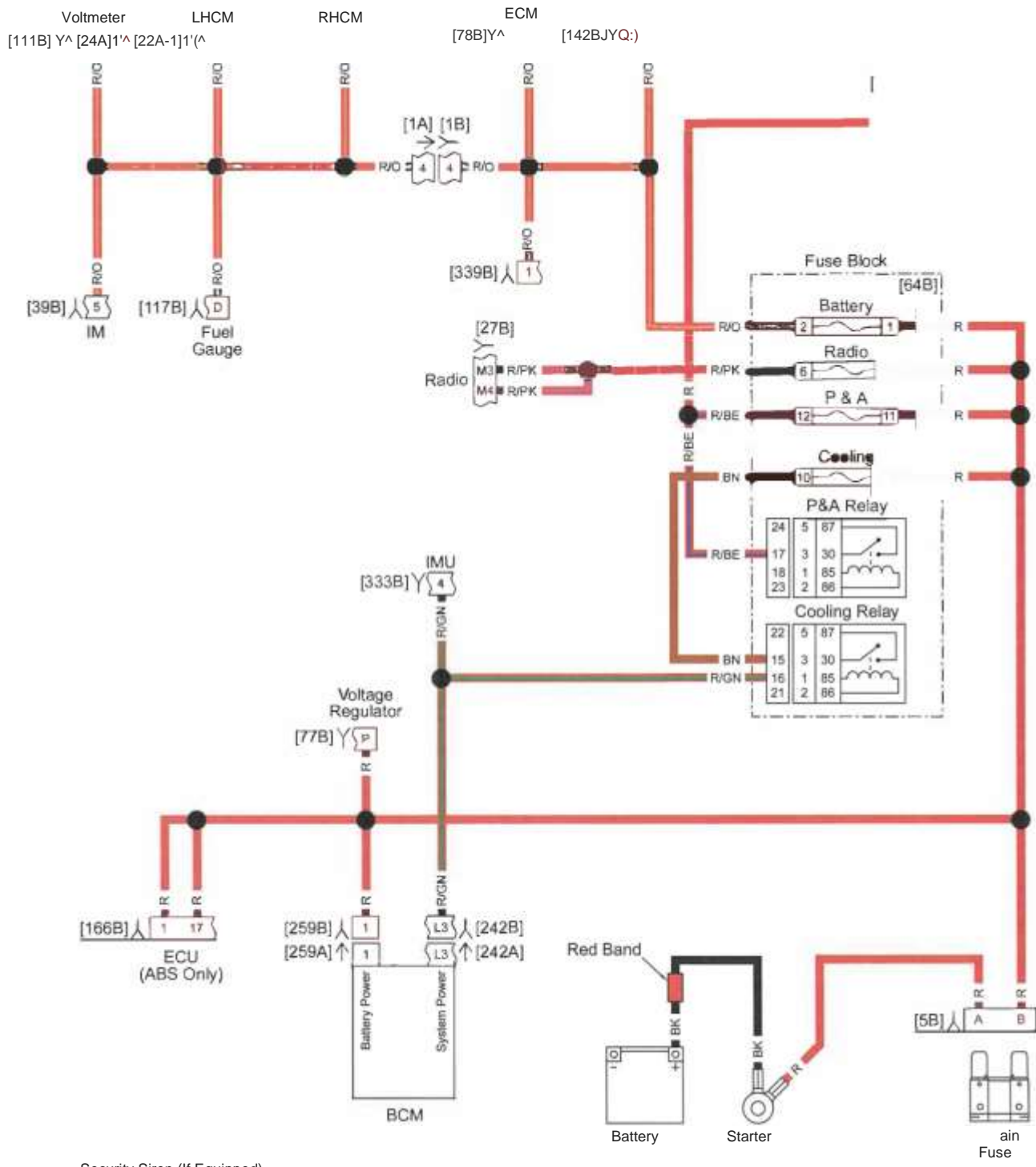
**WIRING DIAGRAM LIST**

| FIGURE   | NUMBER       |
|--|--------------|
| Battery Power Distribution: FLH with Fairing           | Figure A-3.  |
| Battery Power Distribution: FLT                        | Figure A-4.  |
| Battery Power Distribution without Fairing             | Figure A-5.  |
| Ignition and ACC FLH: 2021 Touring                     | Figure A-6.  |
| Ignition and ACC FLT: 2021 Touring                     | Figure A-7.  |
| Sensor Grounds FLH: 2021 Touring                       | Figure A-8.  |
| Sensor Grounds FLT: 2021 Touring                       | Figure A-9.  |
| Ground Circuit FLH: 2021 Touring                       | Figure A-10. |
| Ground Circuit FLT: 2021 Touring                       | Figure A-11. |
| Front Lighting and Hand Controls: 2021 Touring         | Figure A-12. |
| Fairing Harness FLH: 2021 Touring                      | Figure A-13. |
| Main Harness FLH (1 of 3): 2021 Touring (with Fairing) | Figure A-14. |
| Main Harness FLH (2 of 3): 2021 Touring (with Fairing) | Figure A-15. |
| Main Harness FLH (3 of 3): 2021 Touring (with Fairing) | Figure A-16. |
| Fairing Harness FLT: 2021 Touring                      | Figure A-17. |
| Main Harness FLT (1 of 3): 2021 Touring (with Fairing) | Figure A-18. |
| Main Harness FLT (2 of 3): 2021 Touring (with Fairing) | Figure A-19. |
| Main Harness FLT (3 of 3): 2021 Touring (with Fairing) | Figure A-20. |
| Main Harness (1 of 3): 2021 Touring (without Fairing)  | Figure A-21. |
| Main Harness (2 of 3): 2021 Touring (without Fairing)  | Figure A-22. |
| Main Harness (3 of 3): 2021 Touring (without Fairing)  | Figure A-23. |
| Rear Lighting: 2021 Touring                            | Figure A-24. |
| OE Radio: 2021 Touring (Except FLHX/S, FLT)            | Figure A-25. |
| OE Radio: 2021 Touring (No Tour-Pak)                   | Figure A-26. |
| P&A Radio with 1 Amp: 2021 Touring                     | Figure A-27. |



# WIRING DIAGRAM LIST

| FIGURE  | NUMBER       |
|---|--------------|
| P&A Radio with 2 Amps (1 of 2): 2021 Touring                      | Figure A-28. |
| P&A Radio with 2 Amps (2 of 2): 2021 Touring                      | Figure A-29. |
| P&A Radio with 4 Amps (1 of 4), Front Amp: 2021 Touring           | Figure A-30. |
| P&A Radio with 4 Amps (2 of 4), Left Saddlebag Amp: 2021 Touring  | Figure A-31. |
| P&A Radio with 4 Amps (3 of 4), Right Saddlebag Amp: 2021 Touring | Figure A-32. |
| P&A Radio with 4 Amps (4 of 4), Tour-Pak Amp: 2021 Touring        | Figure A-33. |



Security Siren (If Equipped)

Figure A-3. Battery Power Distribution: FLH with Fairing

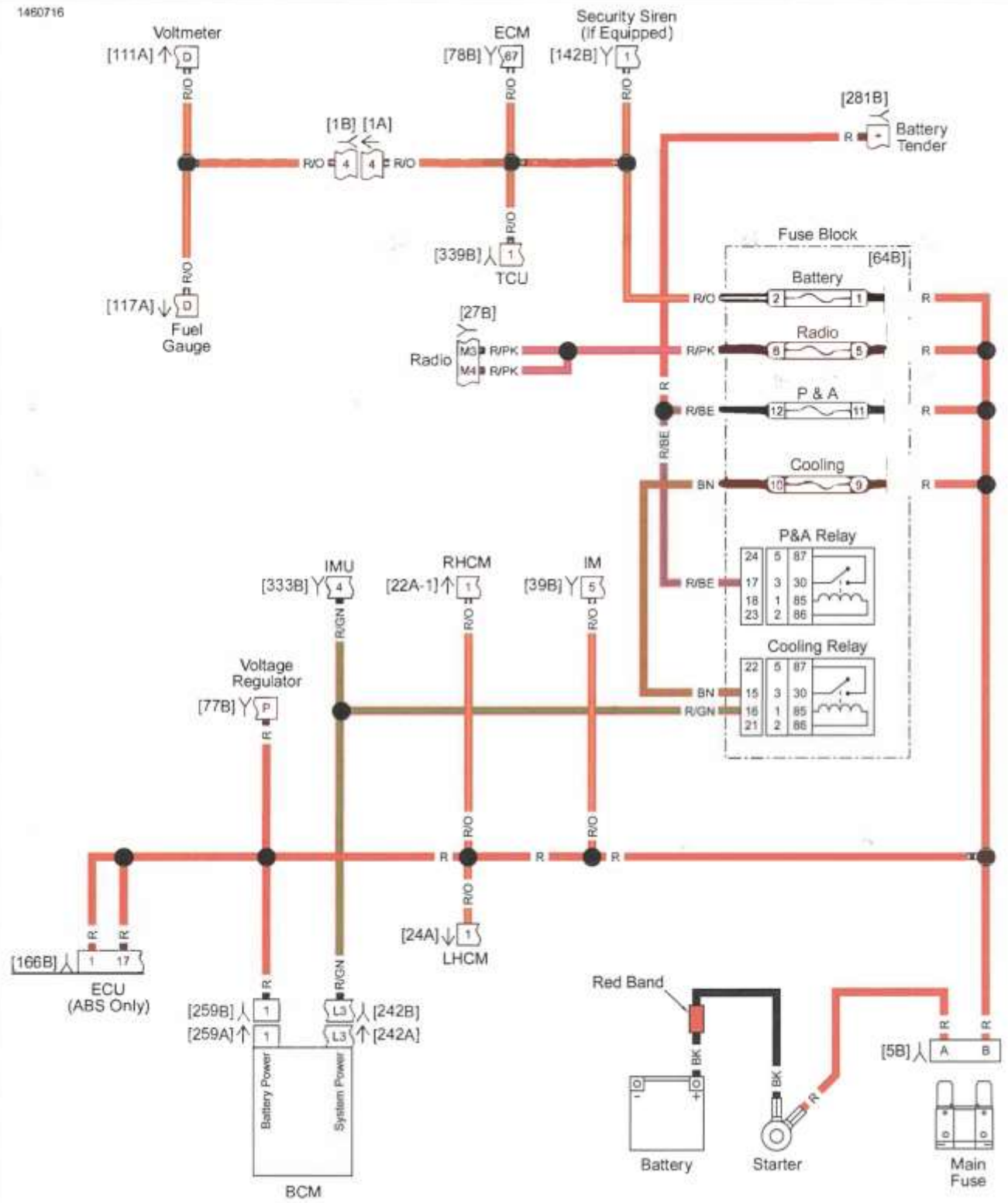
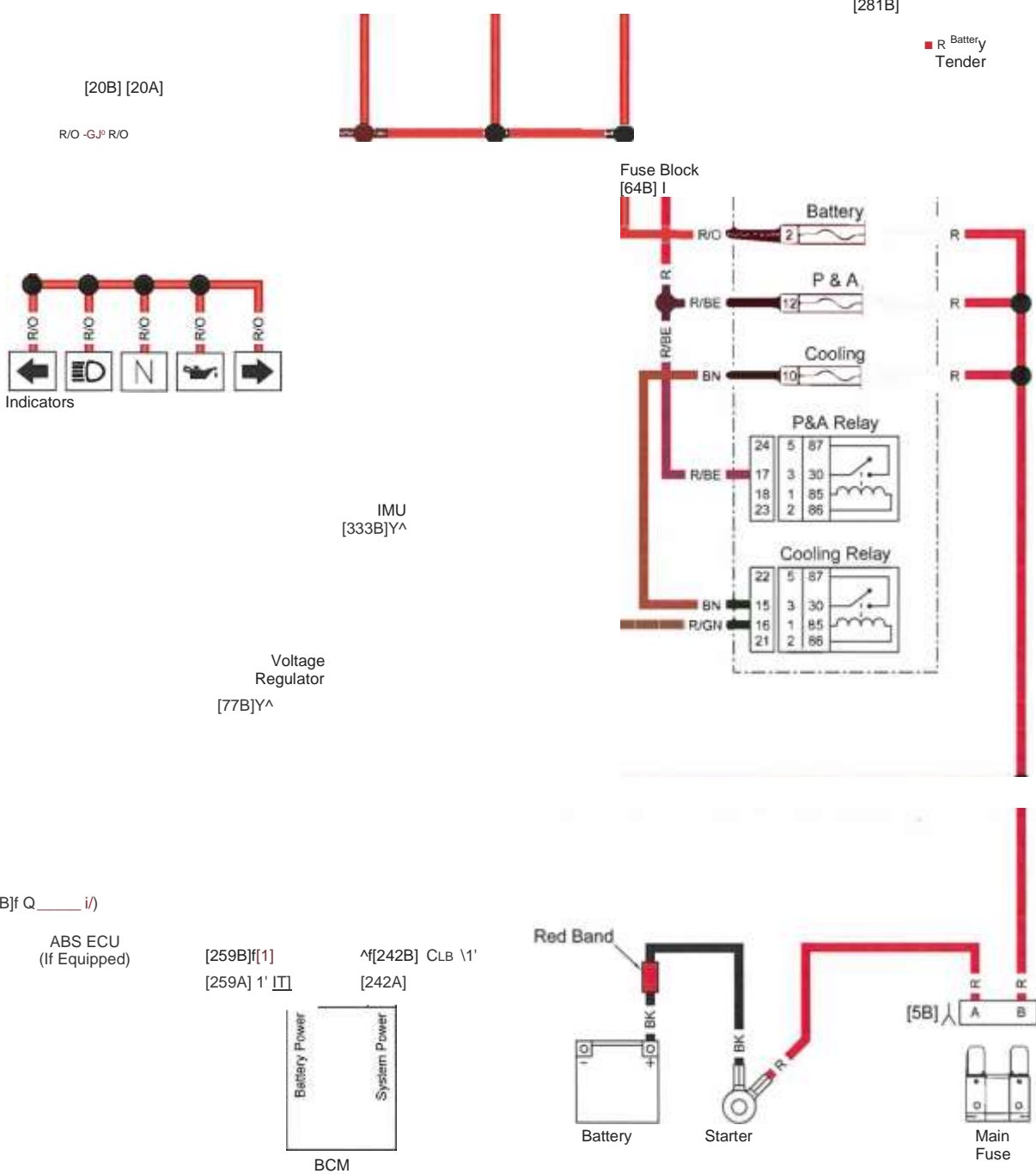


Figure A-4. Battery Power Distribution: FLT

Speedometer [39B]Y^ LHCM [24A]1'8 [22A-1]1'8 RHCM [78B]Y^ [142B]YG ECM (If Equipped) Security Siren

Figure A-5. Battery Power Distribution without Fairing





## NOTES

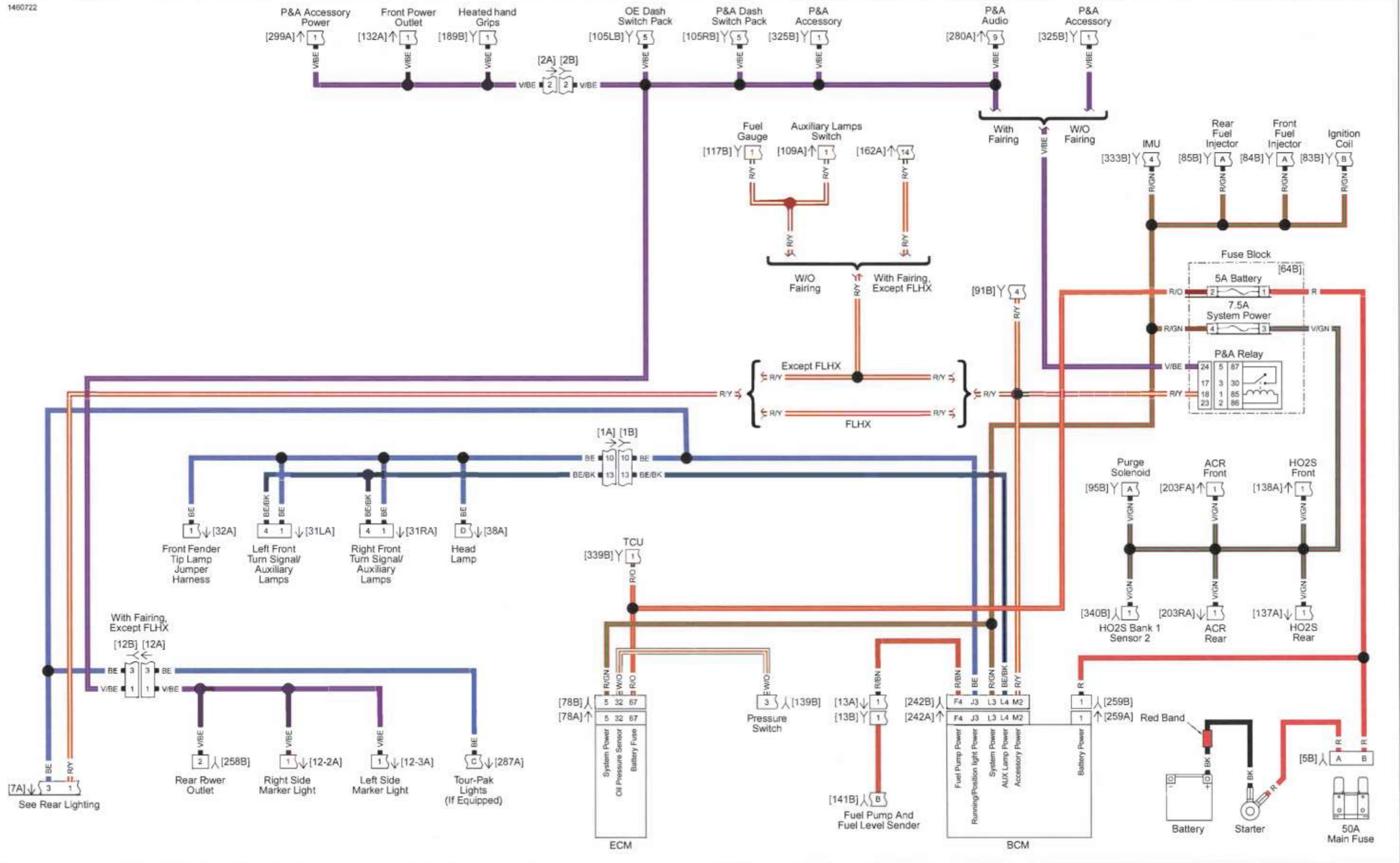


Figure A-6. Ignition and ACC FLH: 2021 Touring





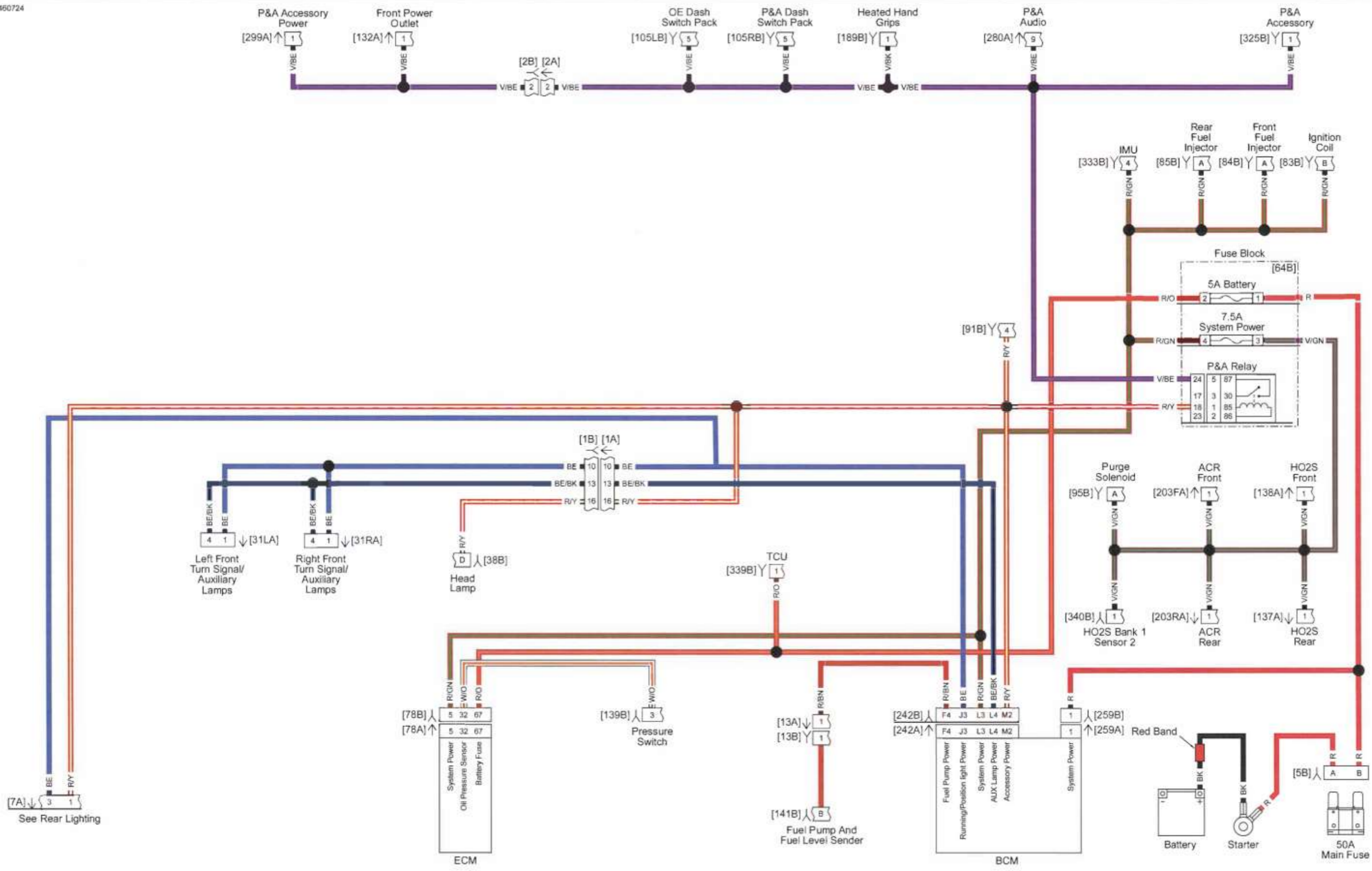


Figure A-7. Ignition and ACC FLT: 2021 Touring





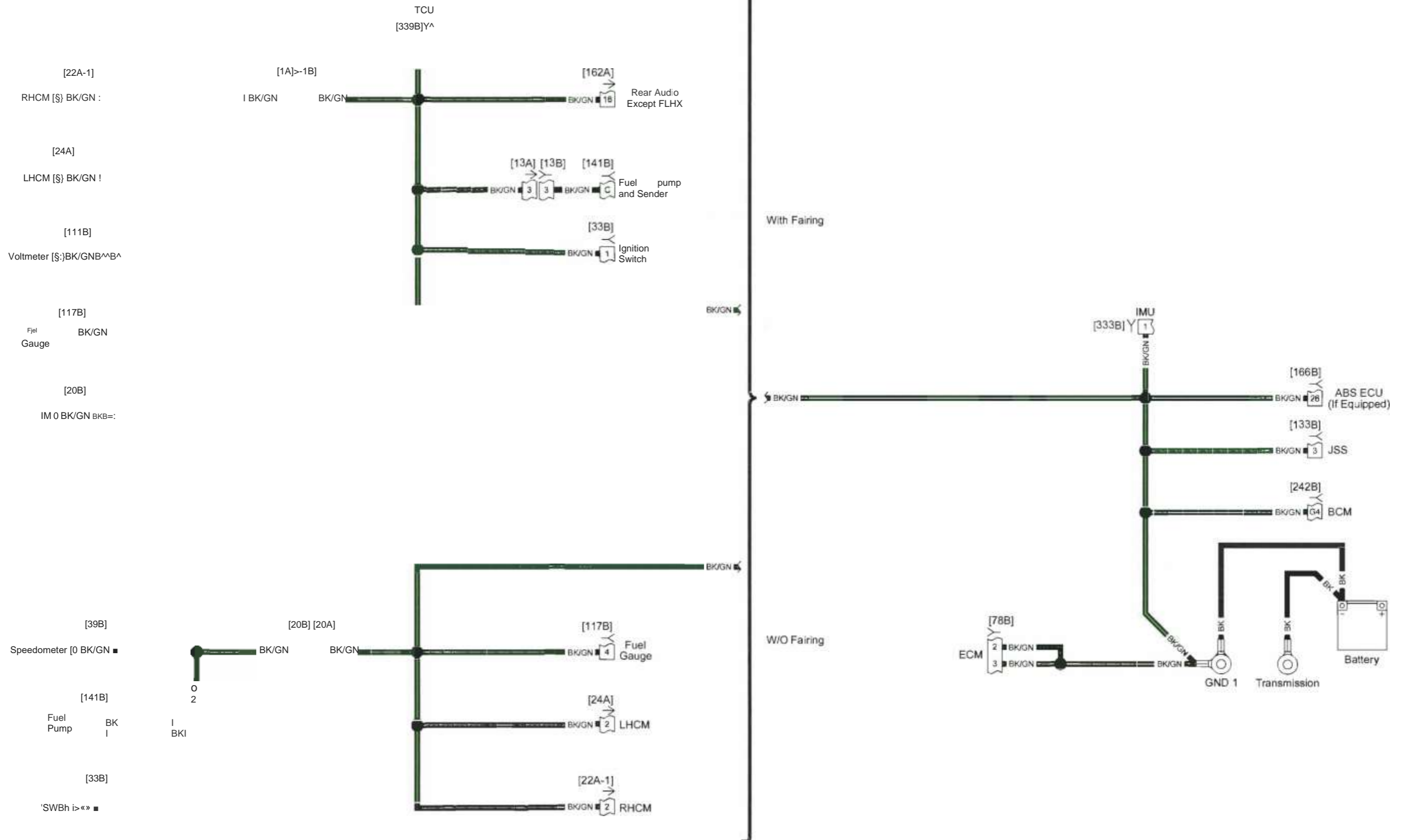


Figure A-8. Sensor Grounds FLH: 2021 Touring

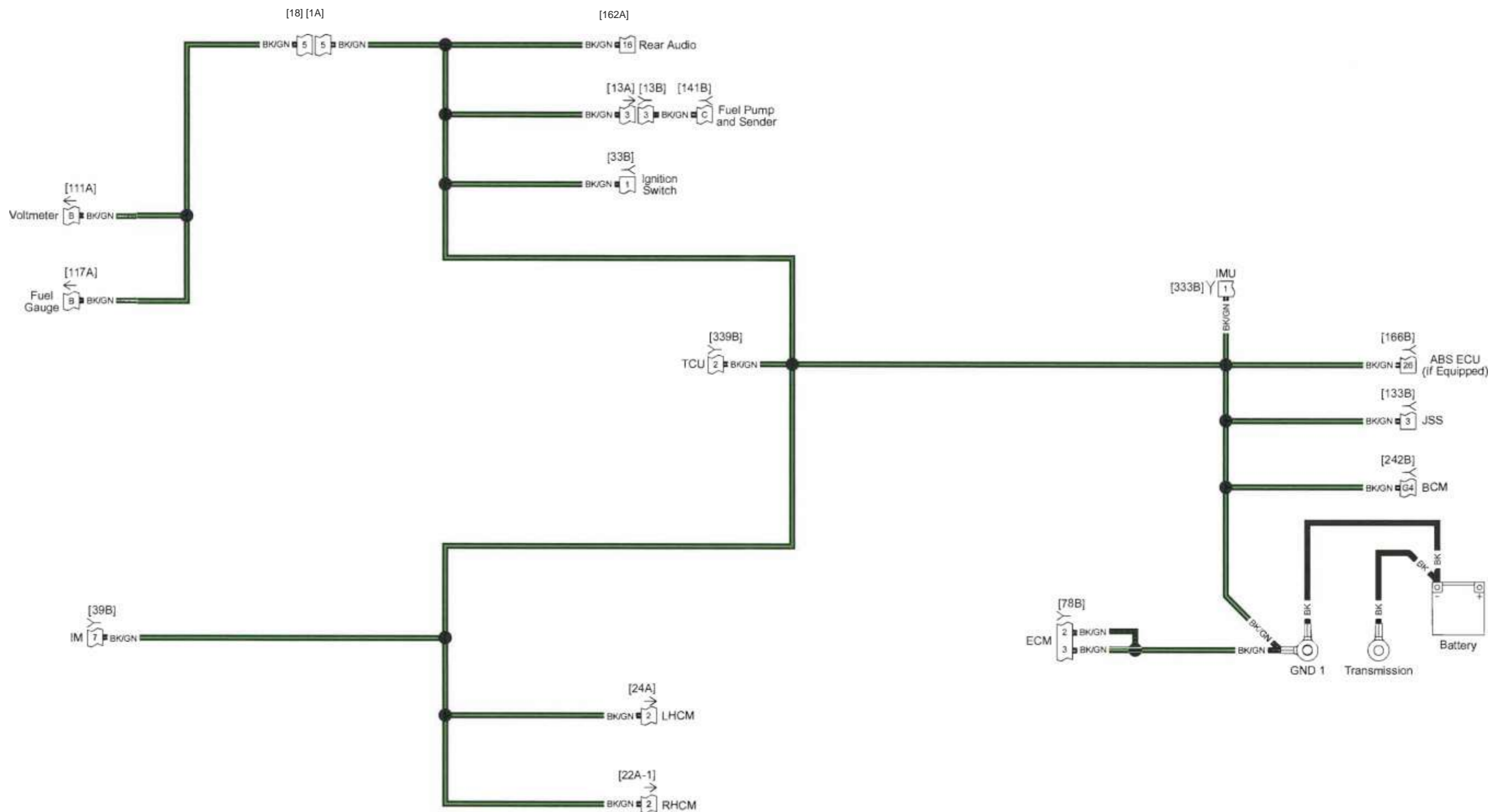


Figure A-9. Sensor Grounds FLT: 2021 Touring

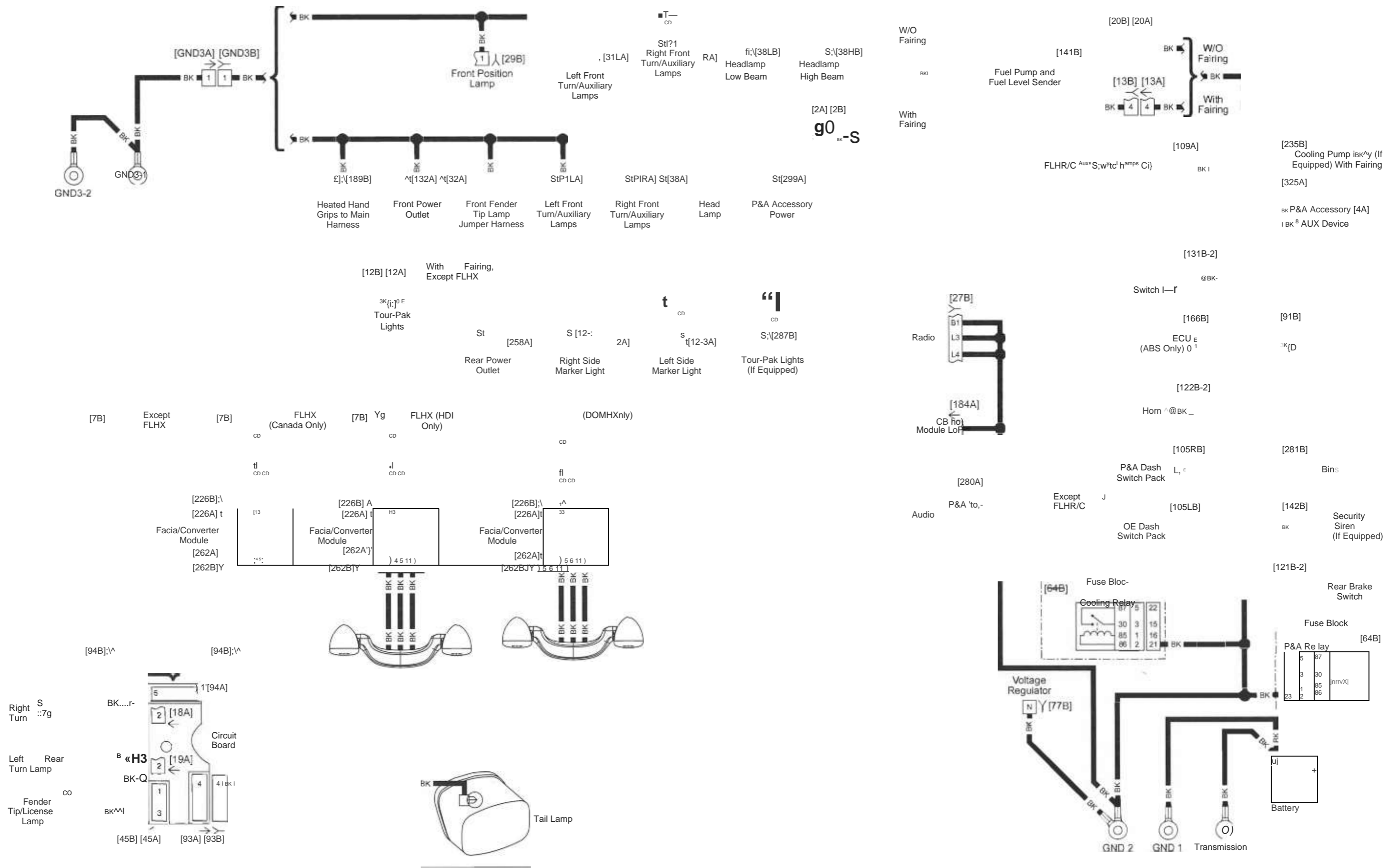


Figure A-10. Ground Circuit FLH: 2021 Touring

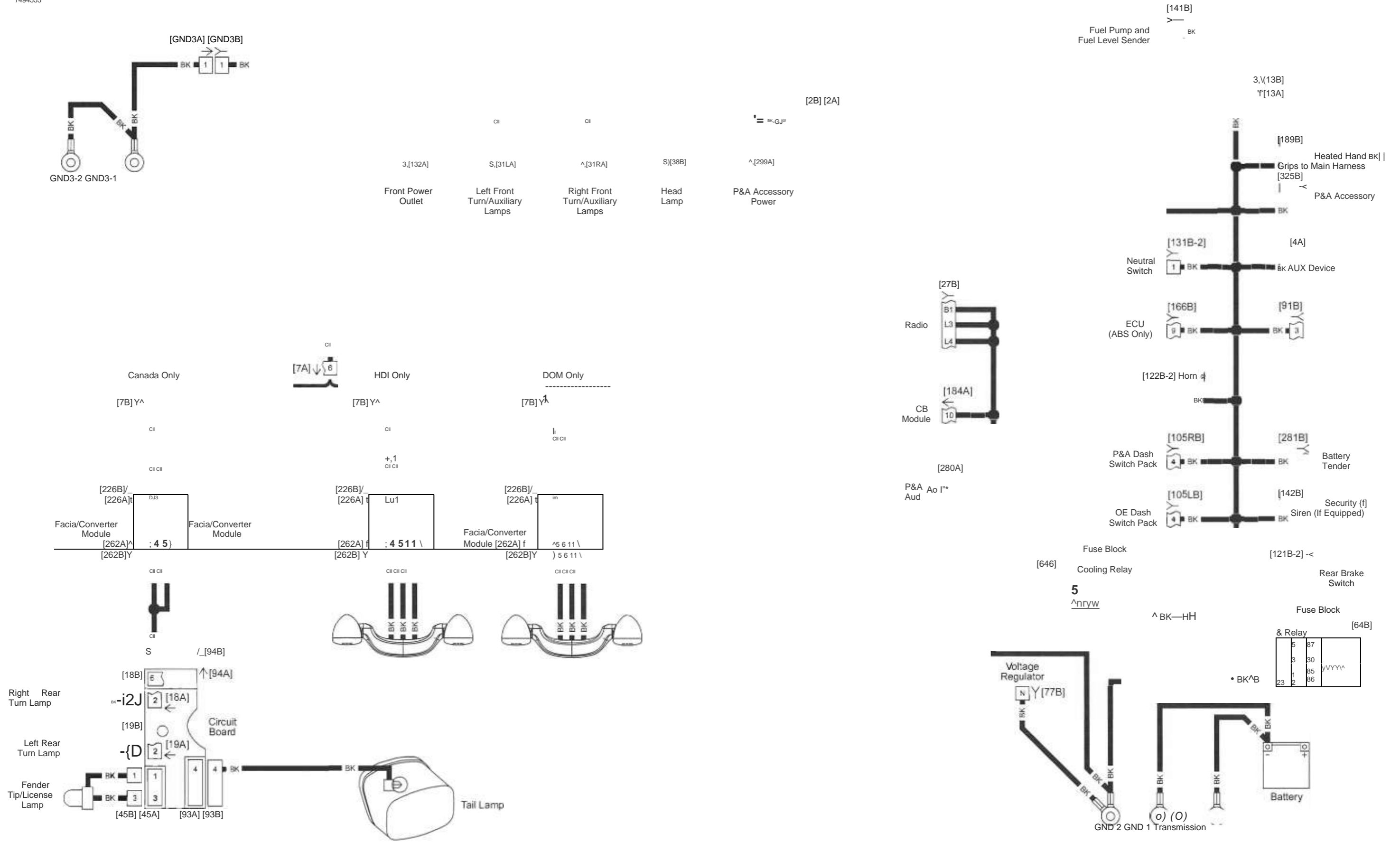


Figure A-11. Ground Circuit FLT: 2021 Touring

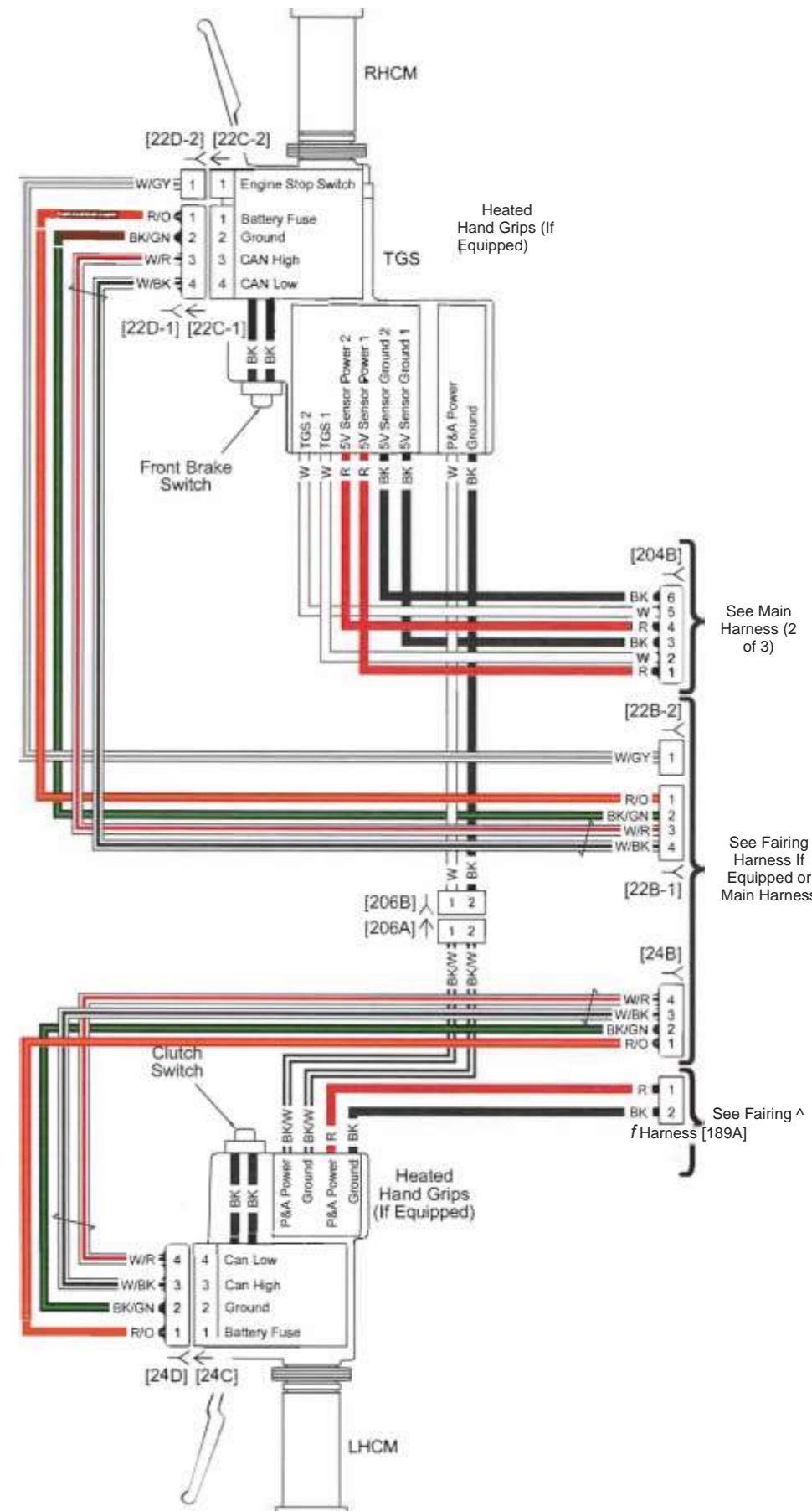
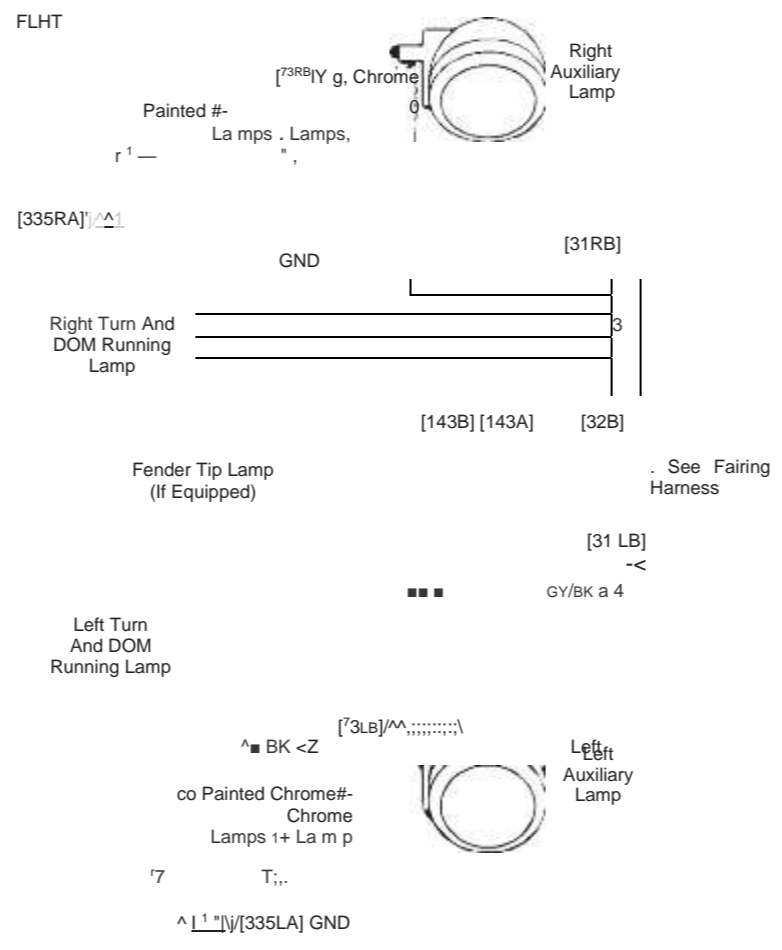
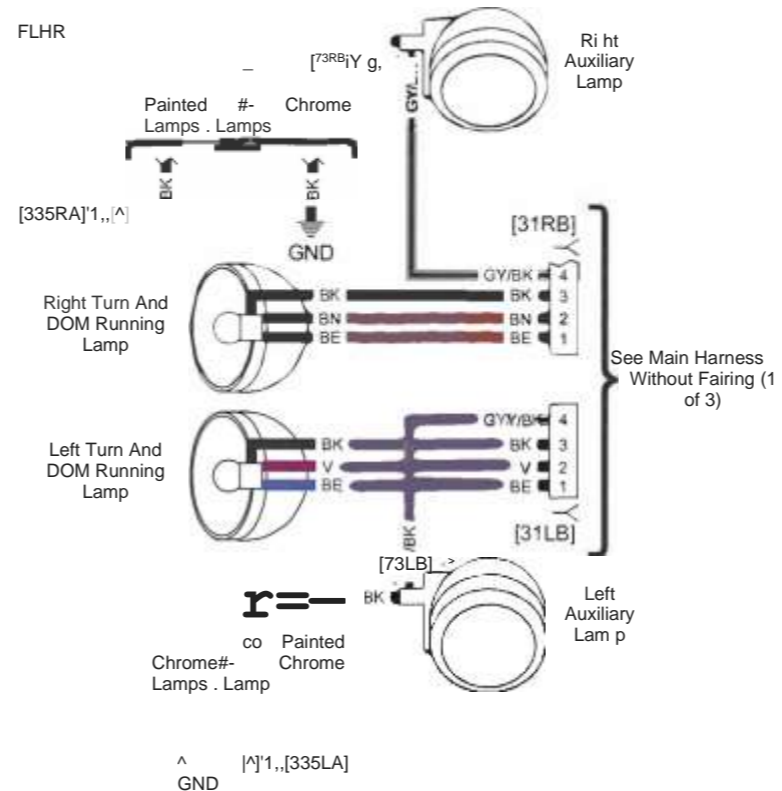
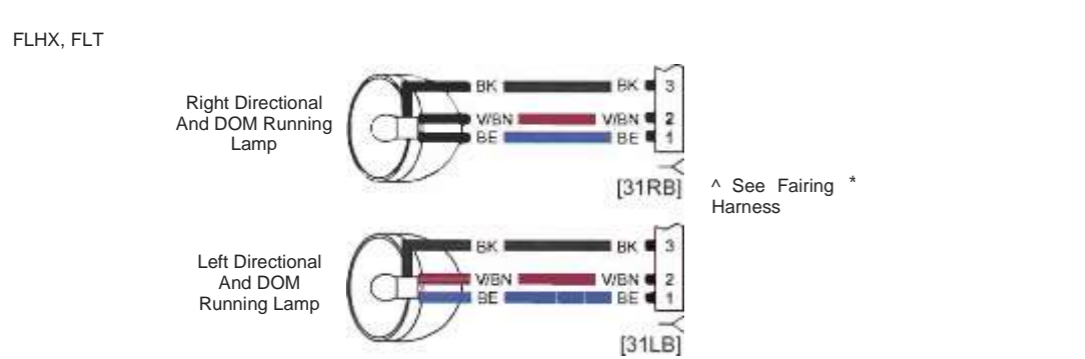
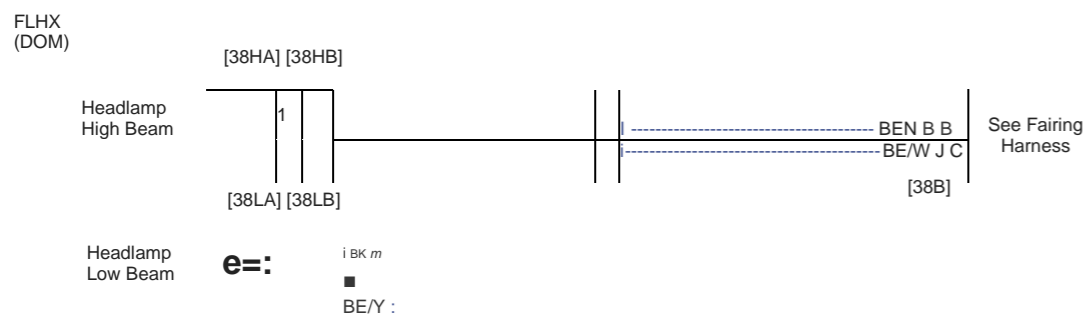
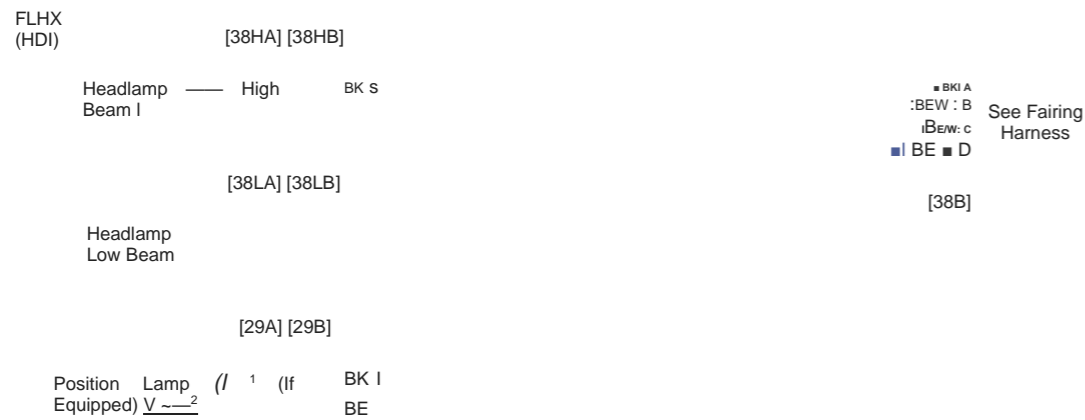


Figure A-12. Front Lighting and Hand Controls: 2021 Touring



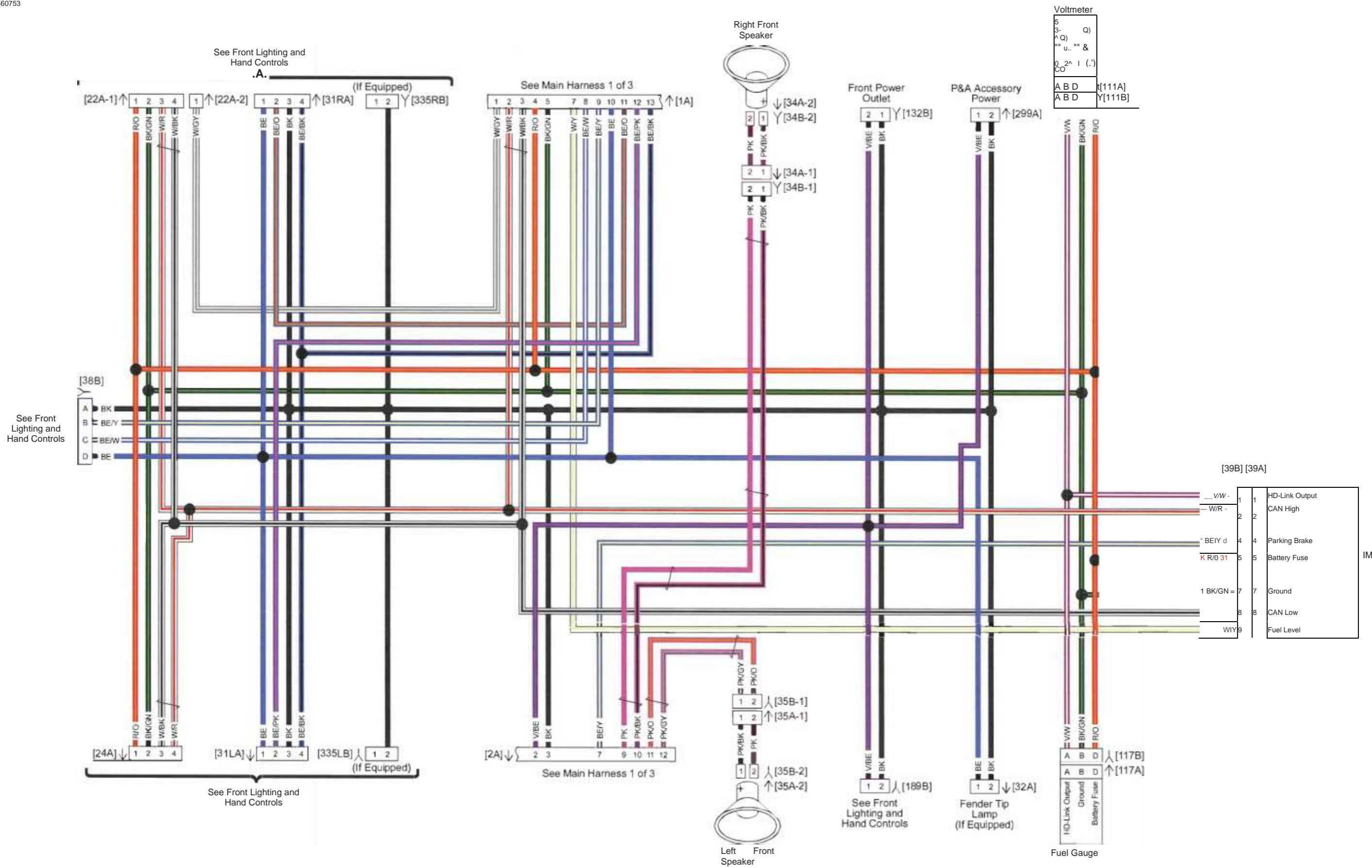


Figure A-13. Fairing Harness FLH: 2021 Touring

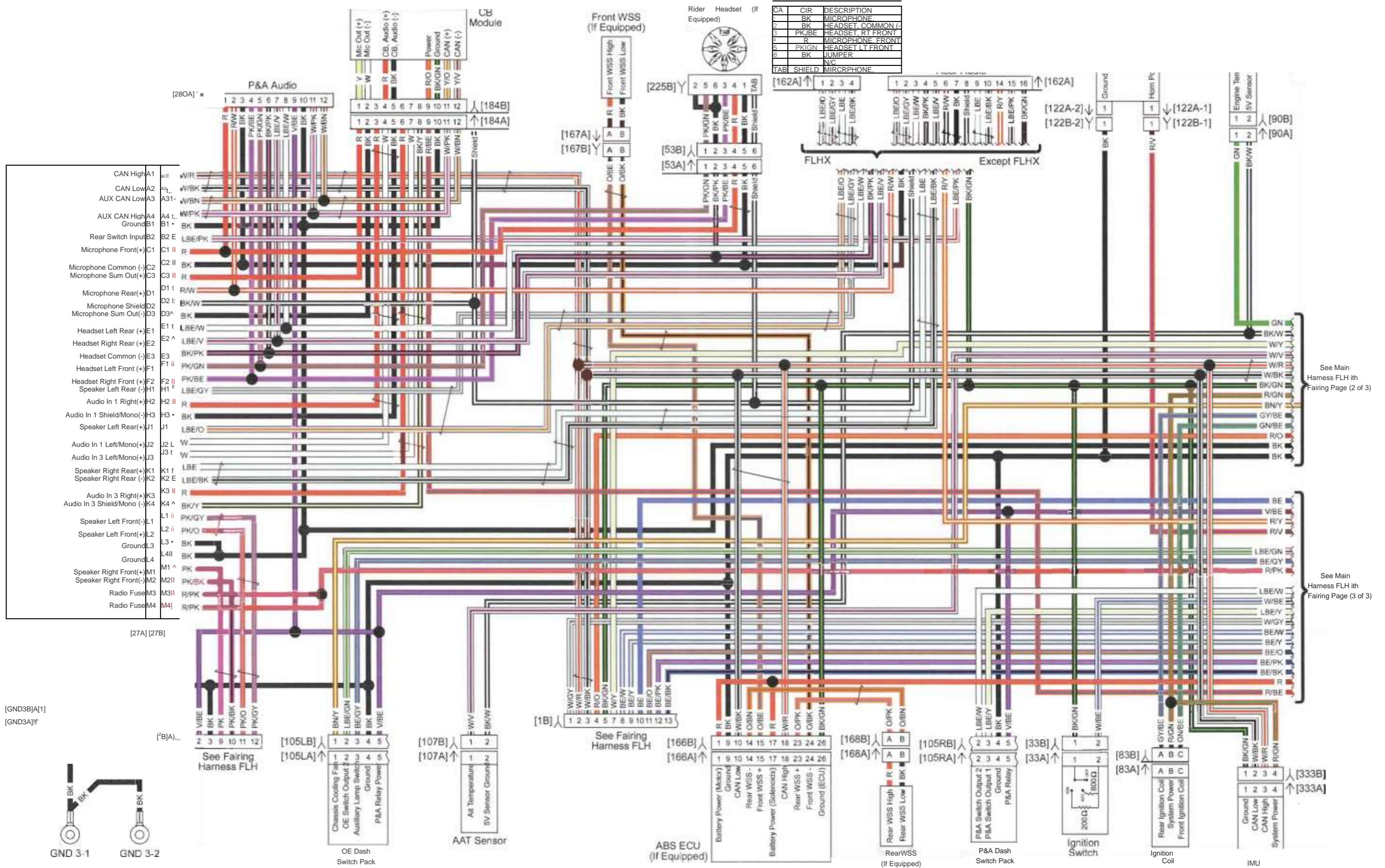


Figure A-14. Main Harness FLH (1 of 3): 2021 Touring (with Fairing)

[203FB]f  
[203FA]f

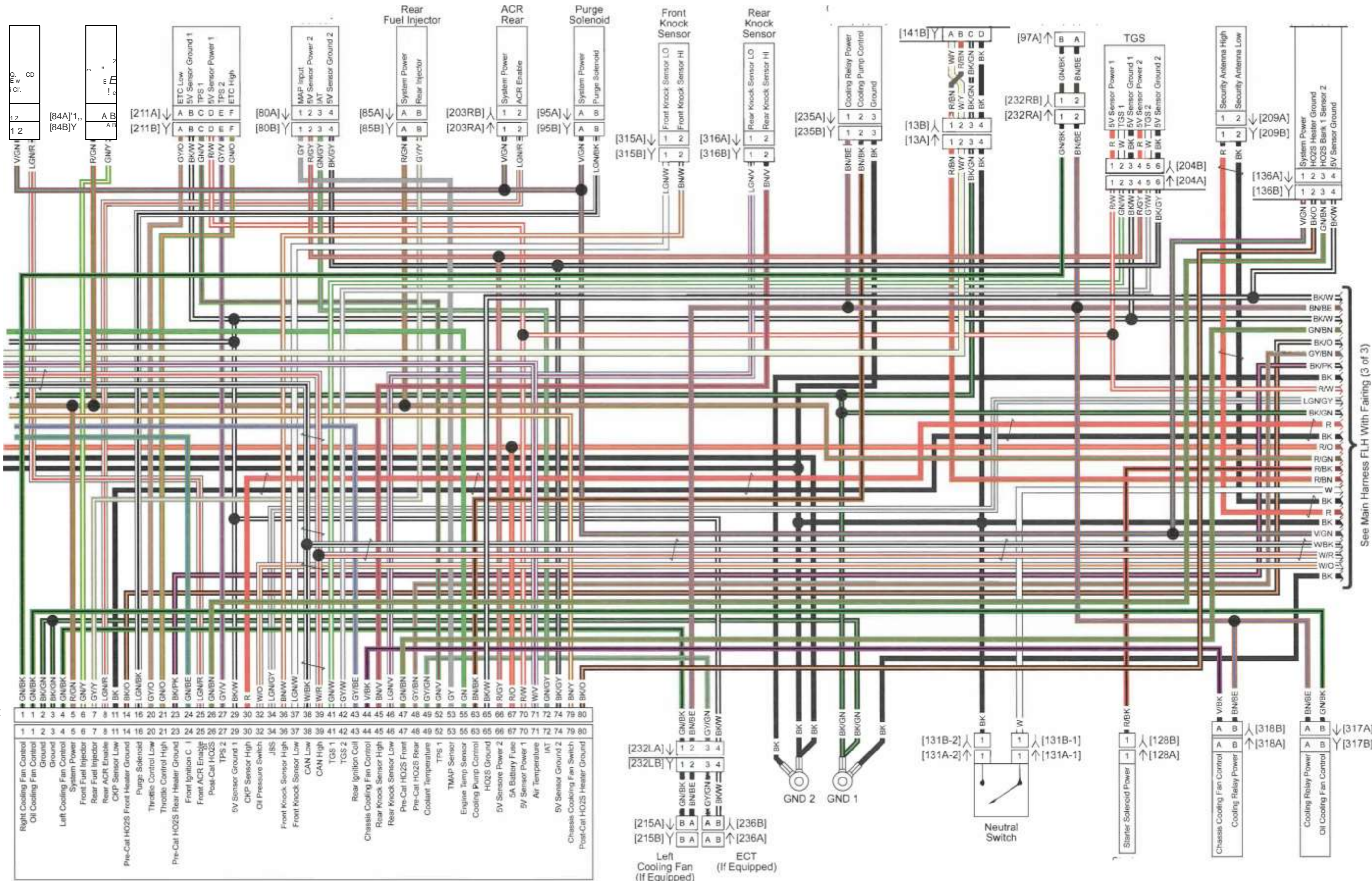
to  
FL

to  
EG

[78B1X]  
[78A]x

GN ■ F

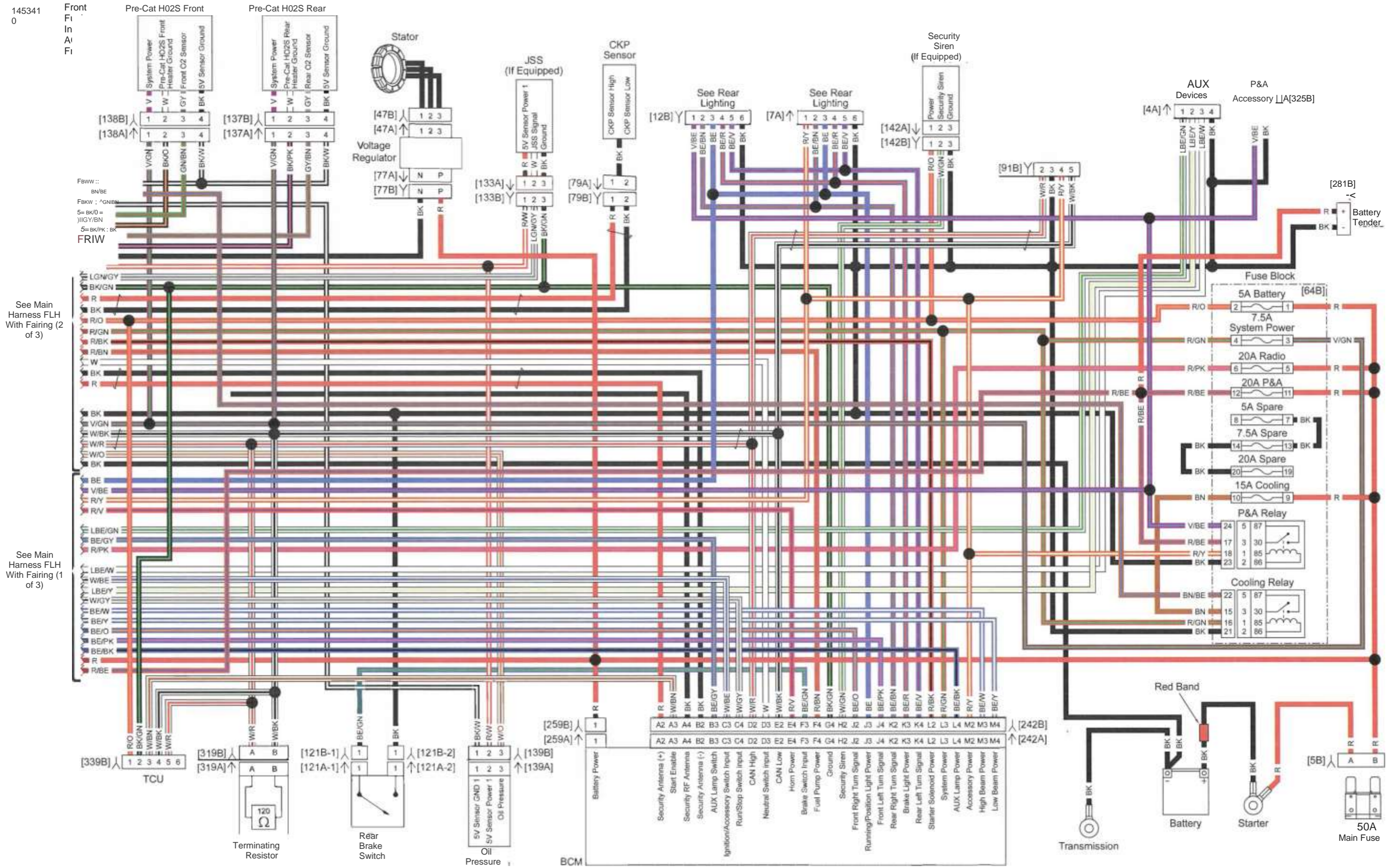
BK/W  
tw  
5;W/  
R  
)',W/B  
.  
BKK  
M AR/G 1  
F BN- i  
GY/ nr ,



See Main Harness FLH With Fairing (3 of 3)

Figure A-15. Main Harness FLH (2 of 3): 2021 Tourin

Figure A-16. Main Harness FLH (1 of 3): 2021 Touring (with Fairing)



See Main  
Harness FLH  
With Fairing (2  
of 3)

See Main  
Harness FLH  
With Fairing (1  
of 3)

Figure  
A-17.  
Main  
Harness  
FLH  
(2 of  
3):  
2021  
Tourin

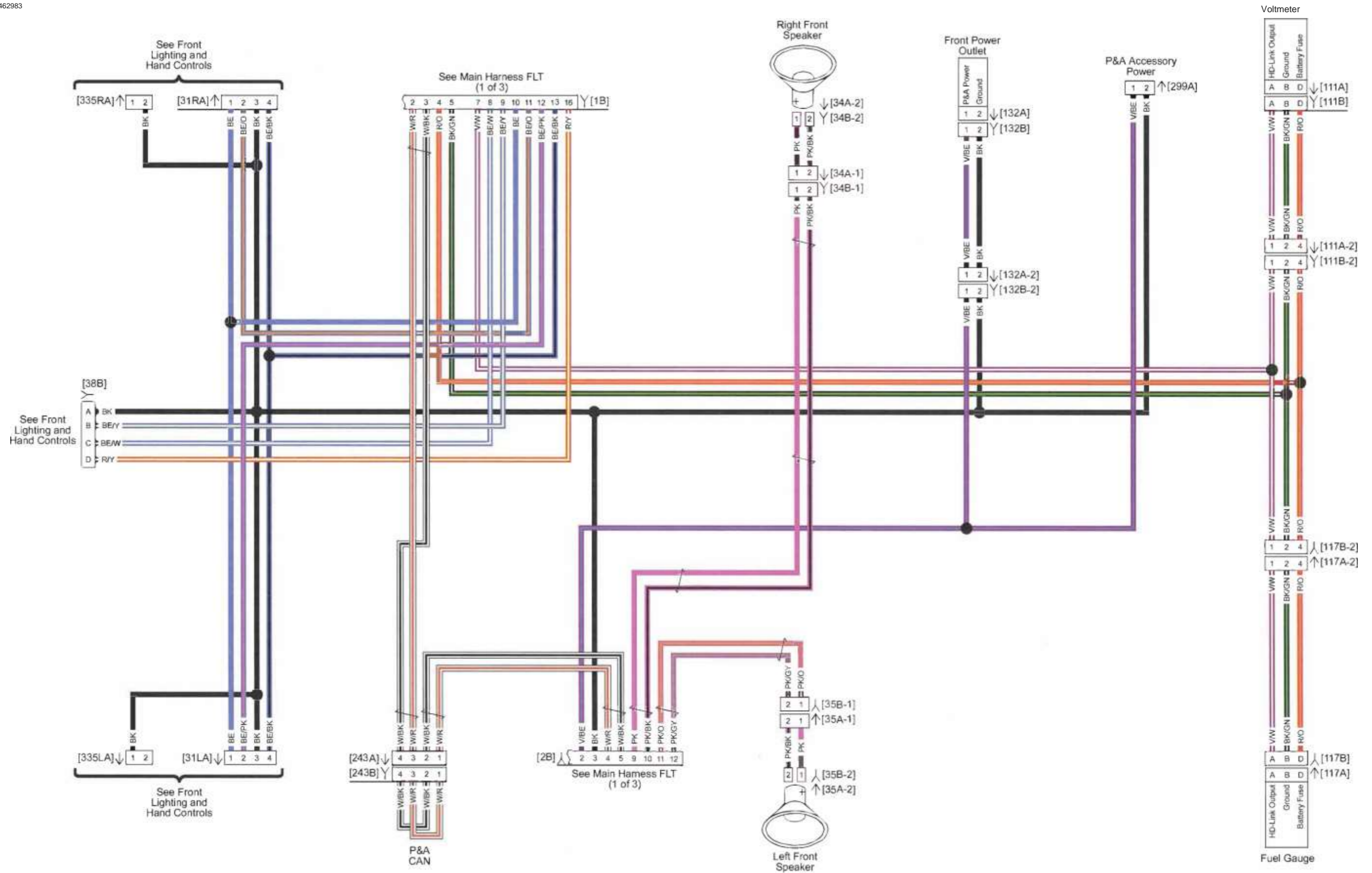
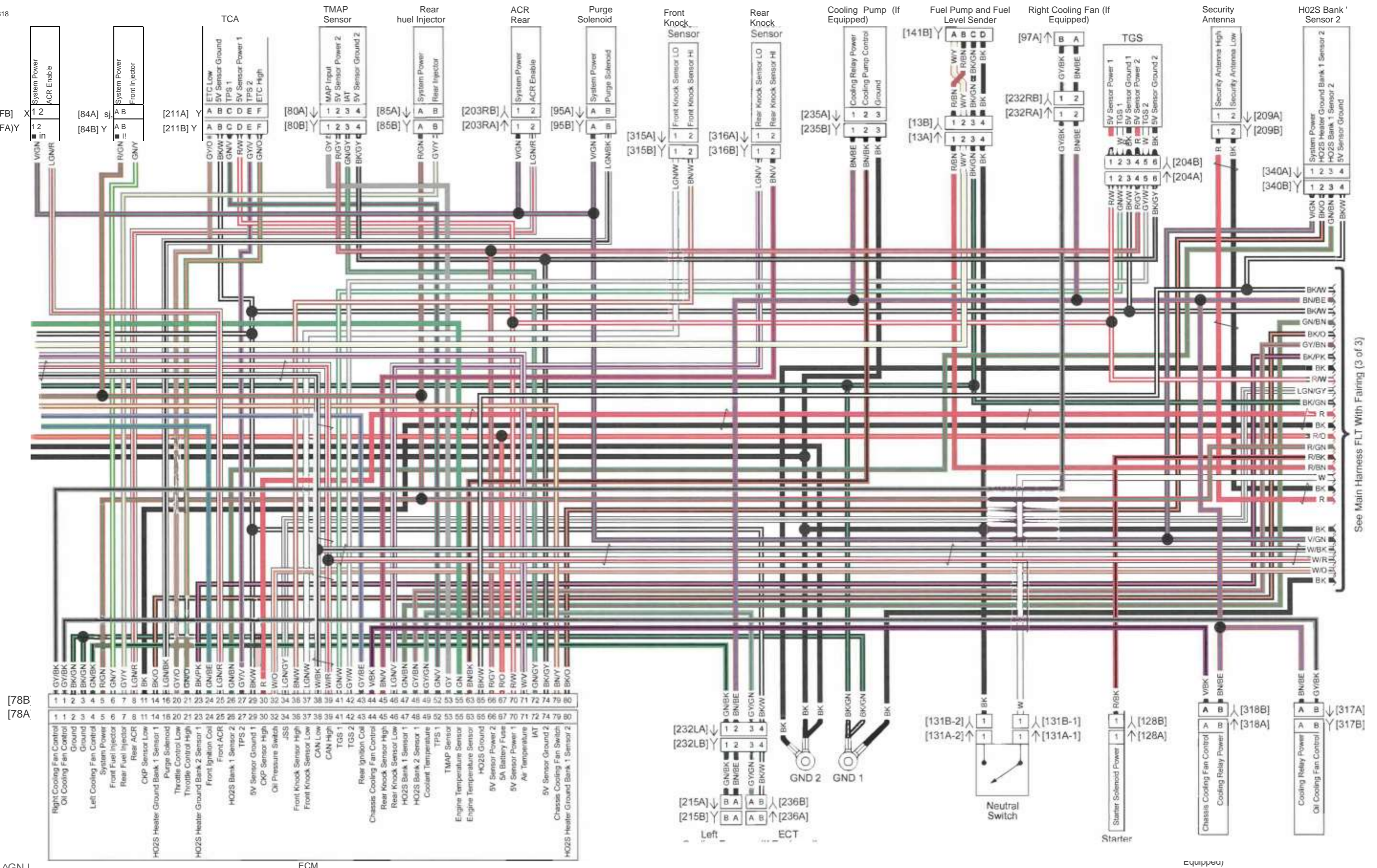


Figure A-18. Fairing Harness FLT: 2021 Touring





See Main Harness FLT With Fairing (3 of 3)

^GN I  
 £BK/W:  
 £w/y:  
 £w/v==  
 £w/R=5  
 ^W/BK  
 = £ BK/GN:  
 ^R/GNI  
 \$=  
 BNry: \$i  
 GY/BE i M

**Figure A-20.**  
**Main Harness FLT (1 of 3): 2021 Touring (with**

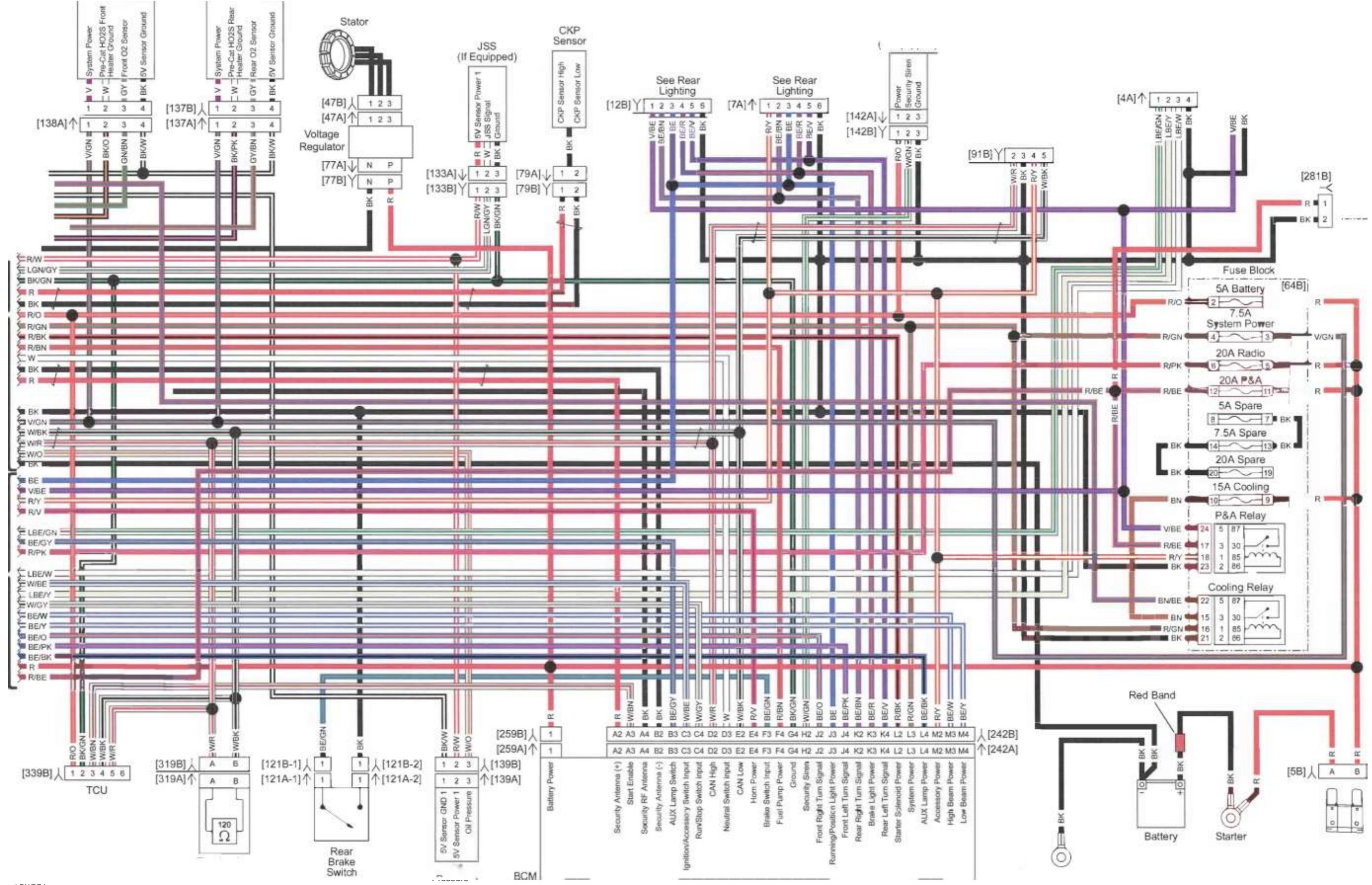


GN/BE Front  
iR/OI Fuel Injector  
^ BK I ACR  
Front

Figure A-21. Main Harness FLT (2 of 3): 2021 Touring (with Fairing)

See Main Harness FLT With Fairing (2 of 3)

See Main Harness FLT With Fairing (1 of 3)



^ BN/BE |  
 ^ BK/W  
 = ^ GN/BN  
 |  
 EBK/O:  
 5° GY/BN | p  
 BK/PK :  
 ^ BK |

**Figure A-22.**  
**Main Harness FLT (1 of 3): 2021 Touring (with**

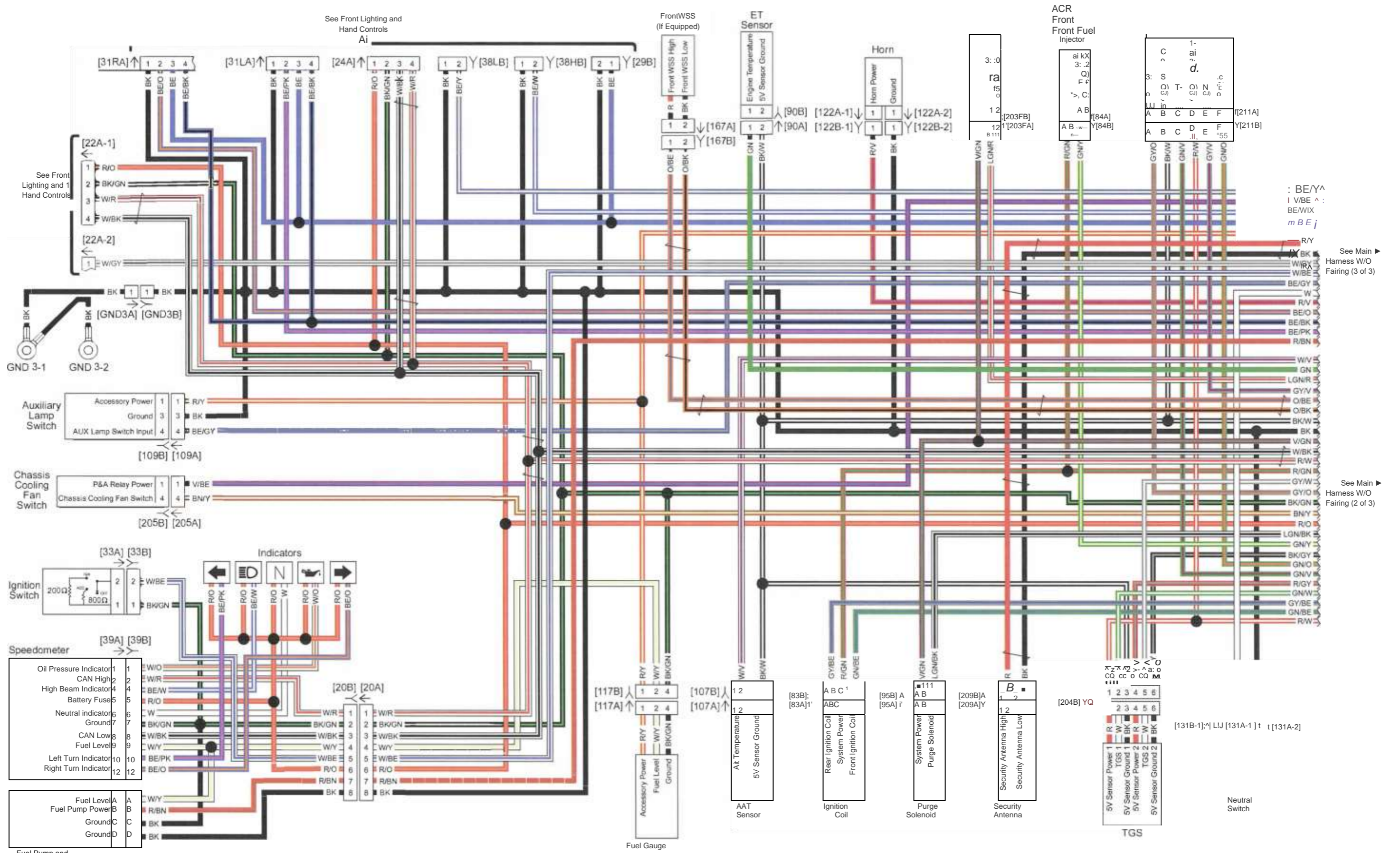
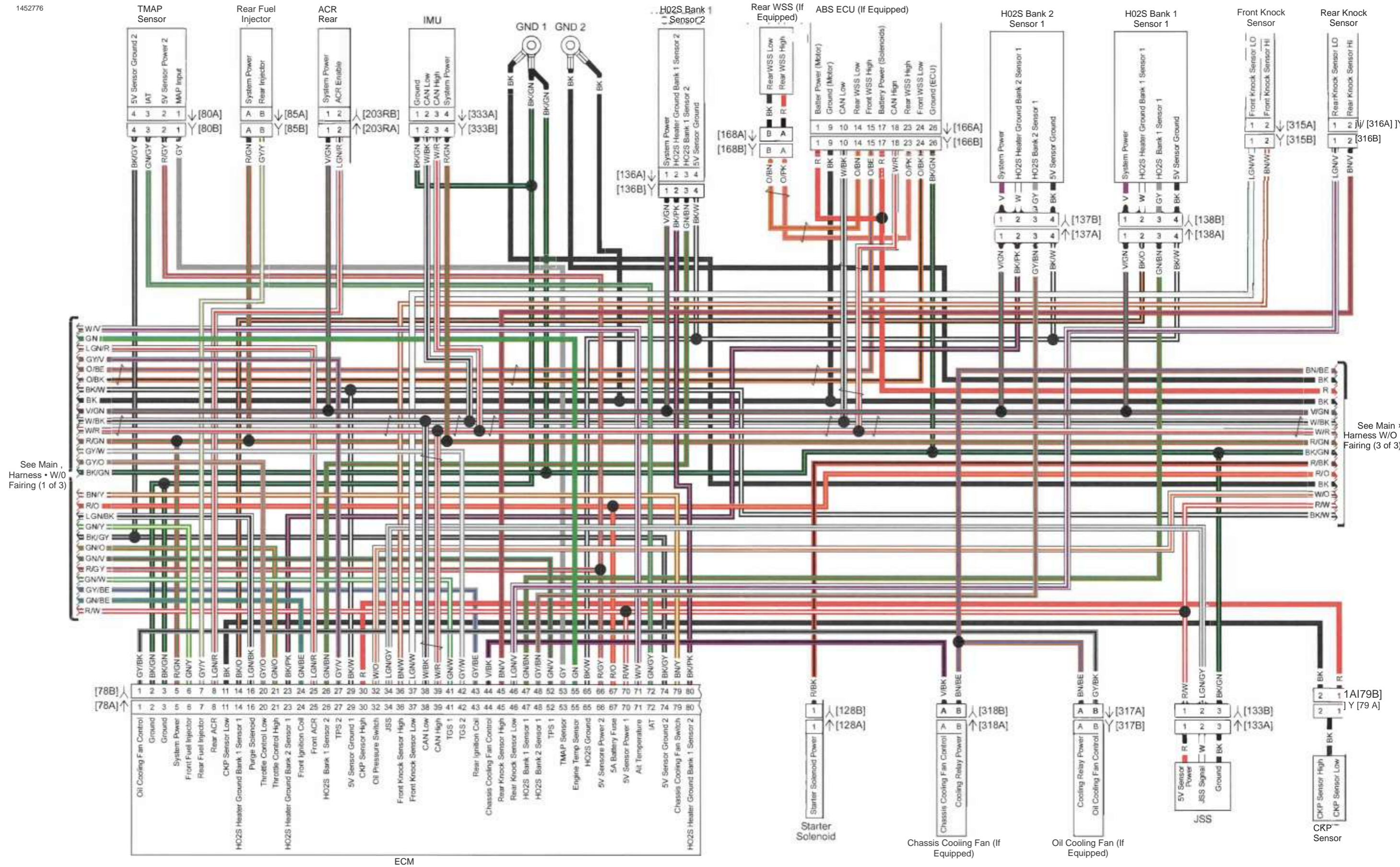


Figure A-23. Main Harness (1 of 3): 2021 Touring (without Fairing)

Fuel Pump and Fuel Level Sender [141 A] [141B]

See Main Harness W/O Fairing (3 of 3)

See Main Harness W/O Fairing (2 of 3)



See Main ,  
Harness • W/O  
Fairing (1 of 3)

See Main ,  
Harness W/O  
Fairing (3 of 3)

Figure A-24. Main Harness (2 of 3): 2021 Touring (without Fairing)

See Main  
Harness W/O  
Fairing (1 of 3)

See Main  
Harness W/O  
Fairing (2 of 3)

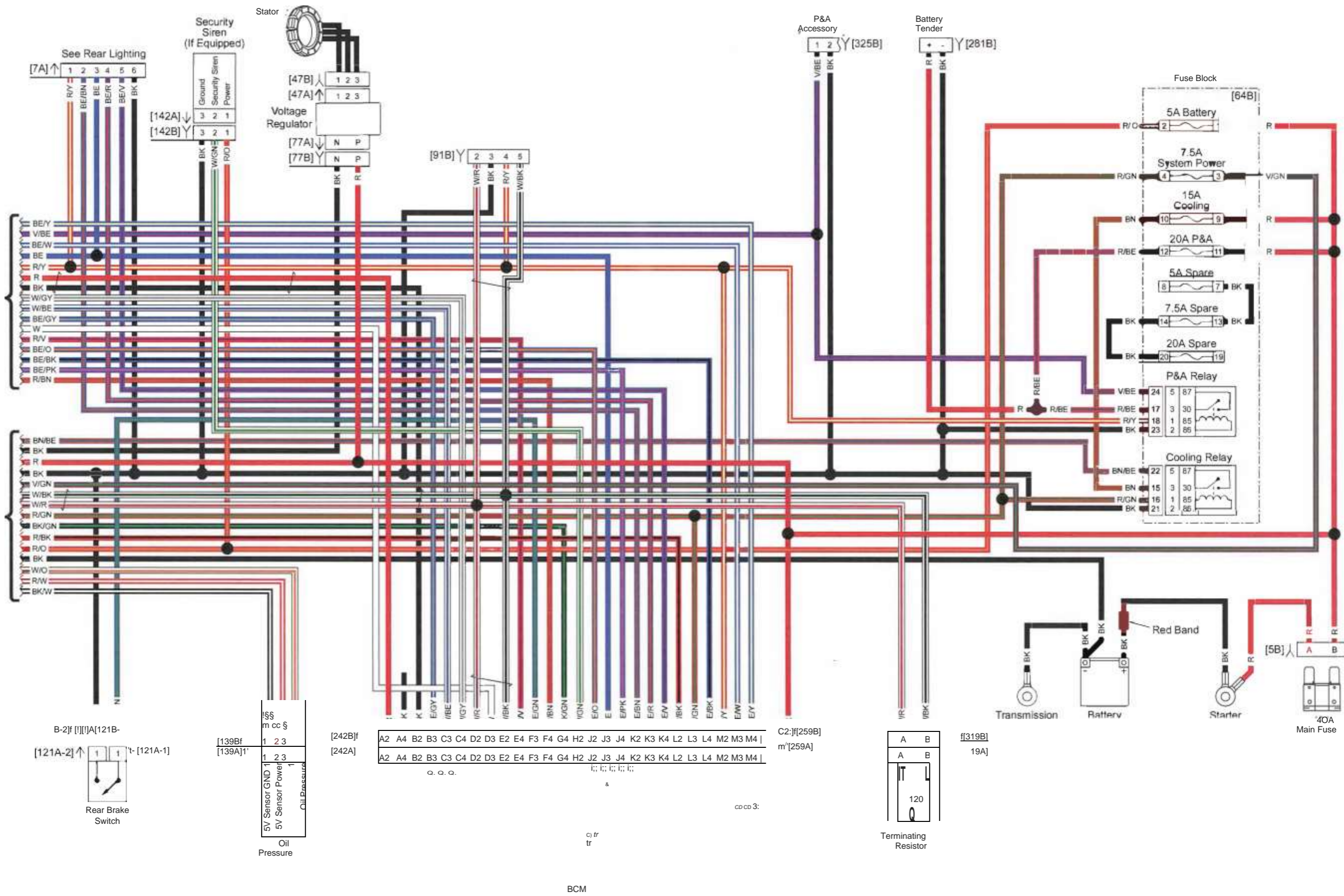


Figure A-25. Main Harness (2 of 3): 2021 Touring (without Fairing)

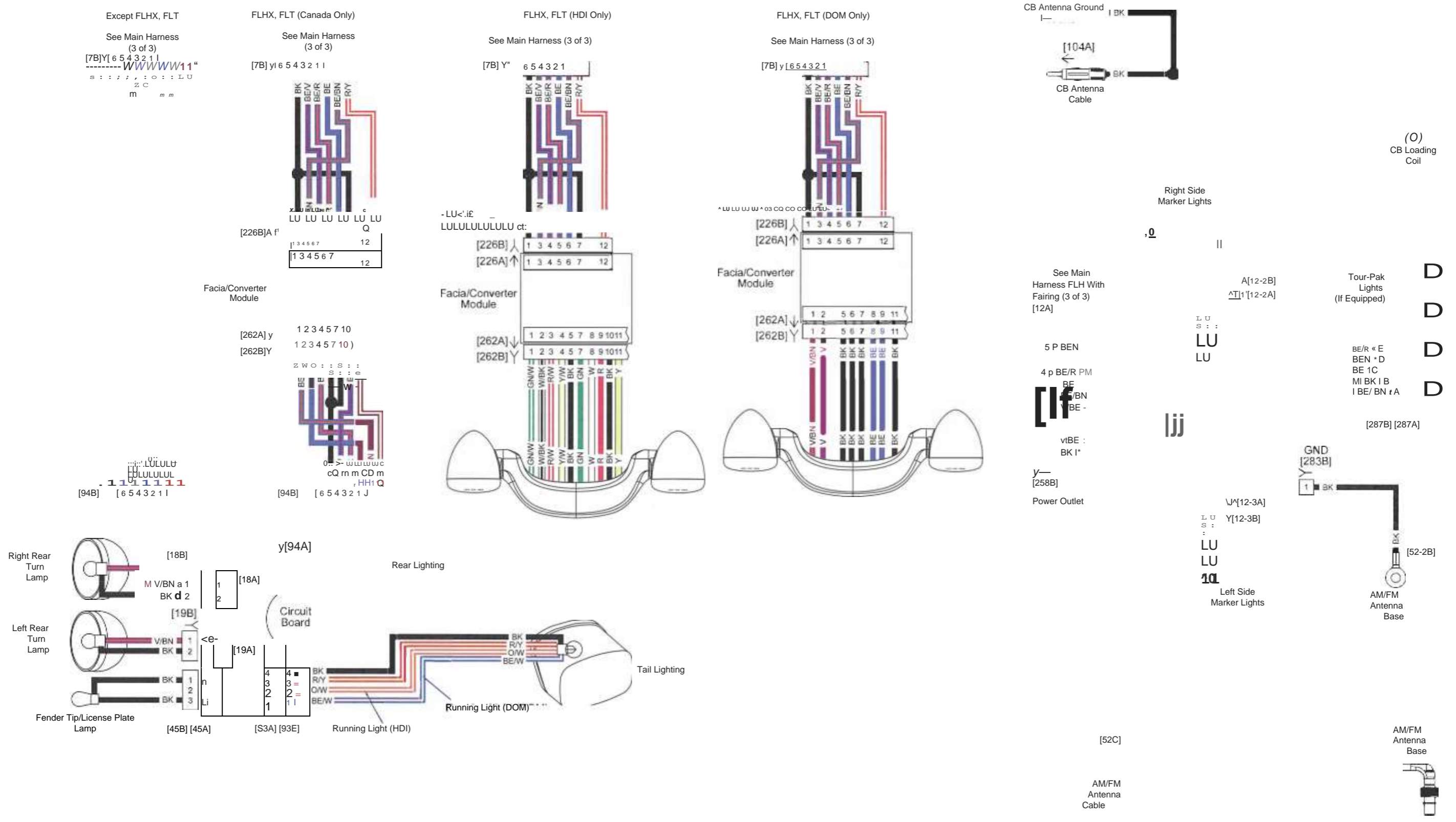


Figure A-26. Rear Lighting: 2021 Touring

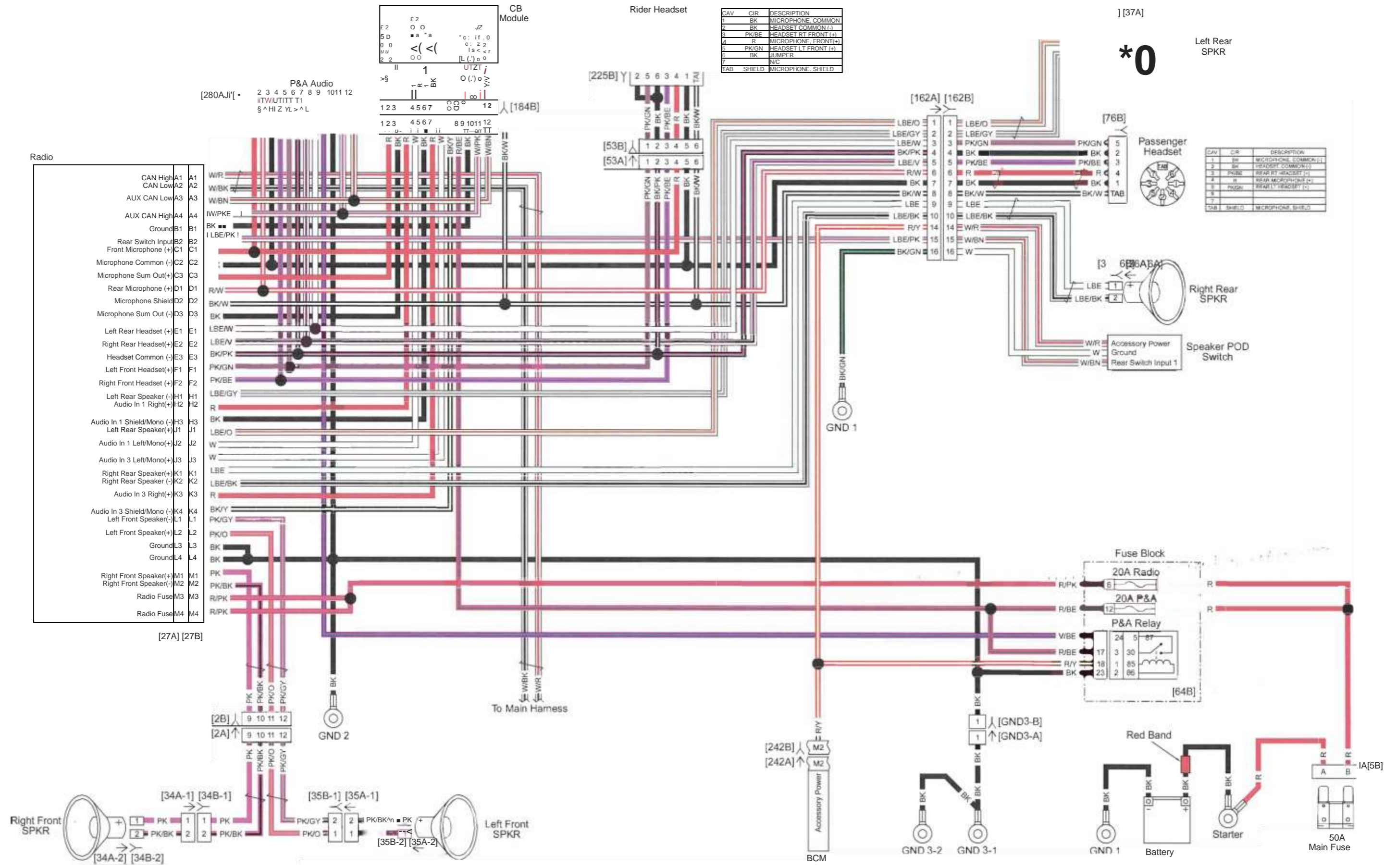
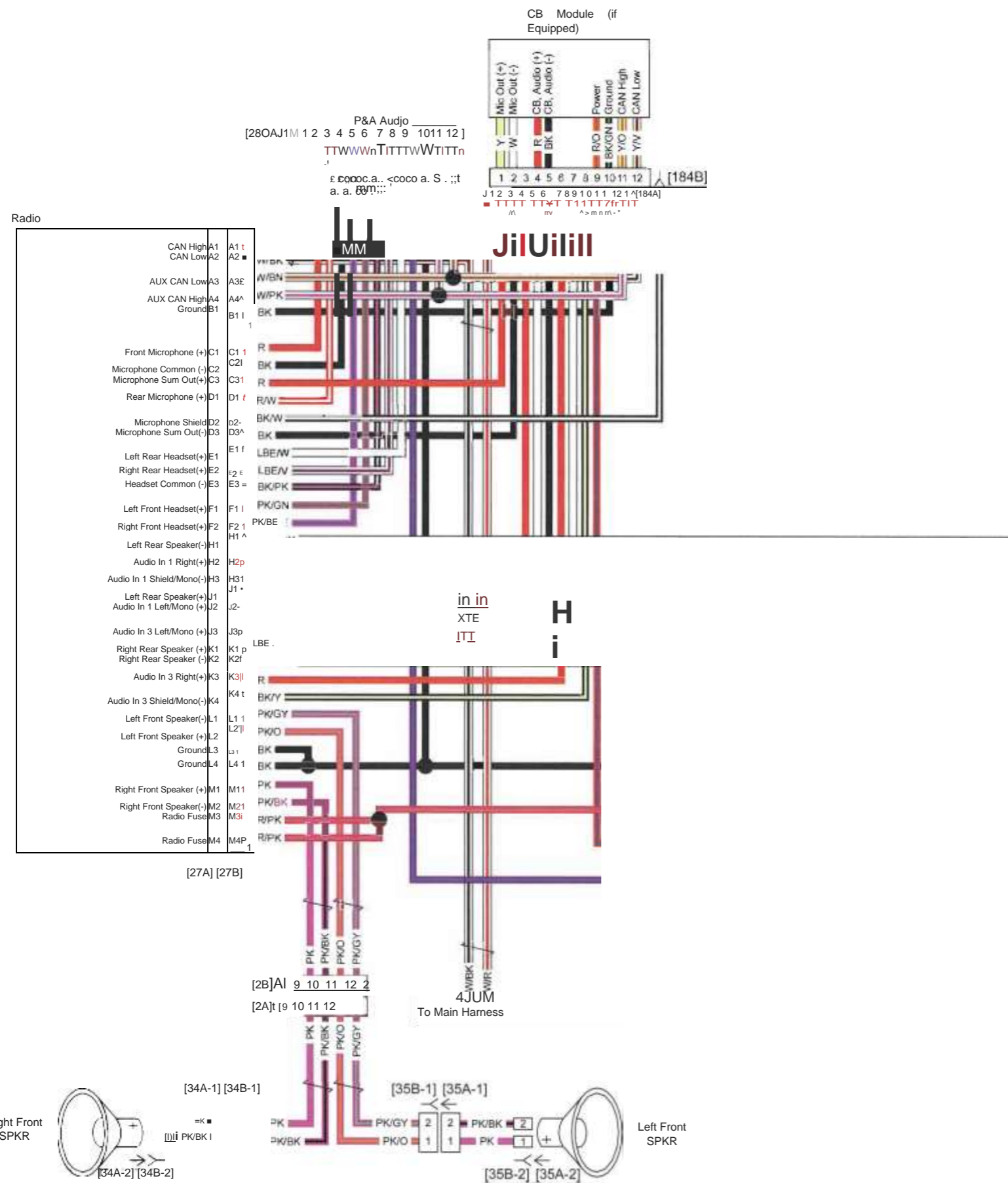


Figure A-27. OE Radio: 2021 Touring (Except FLHX/S, FLT)



[162A]  
->  
■ LSE/O - 1!  
LBE/GY / 2!  
LBE LBE/BK

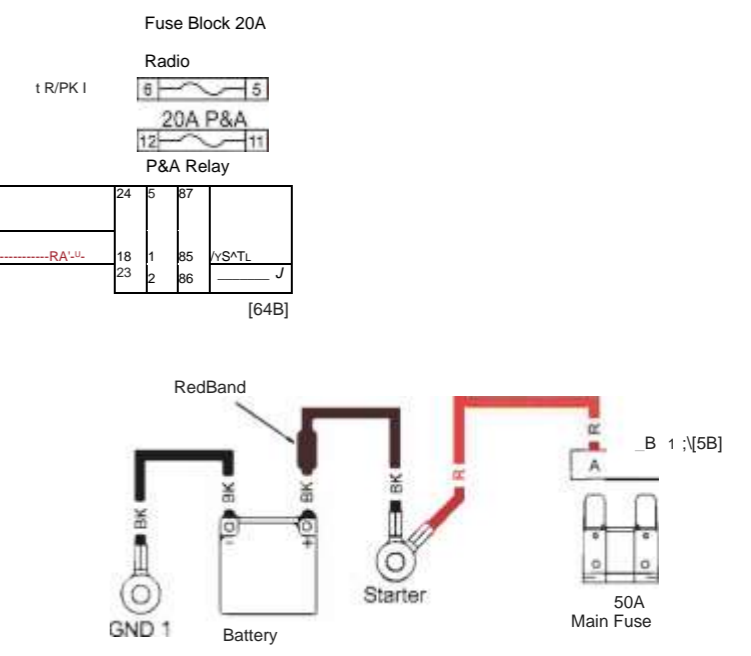


Figure A-28. OE Radio: 2021 Touring (No Tour-Pak)



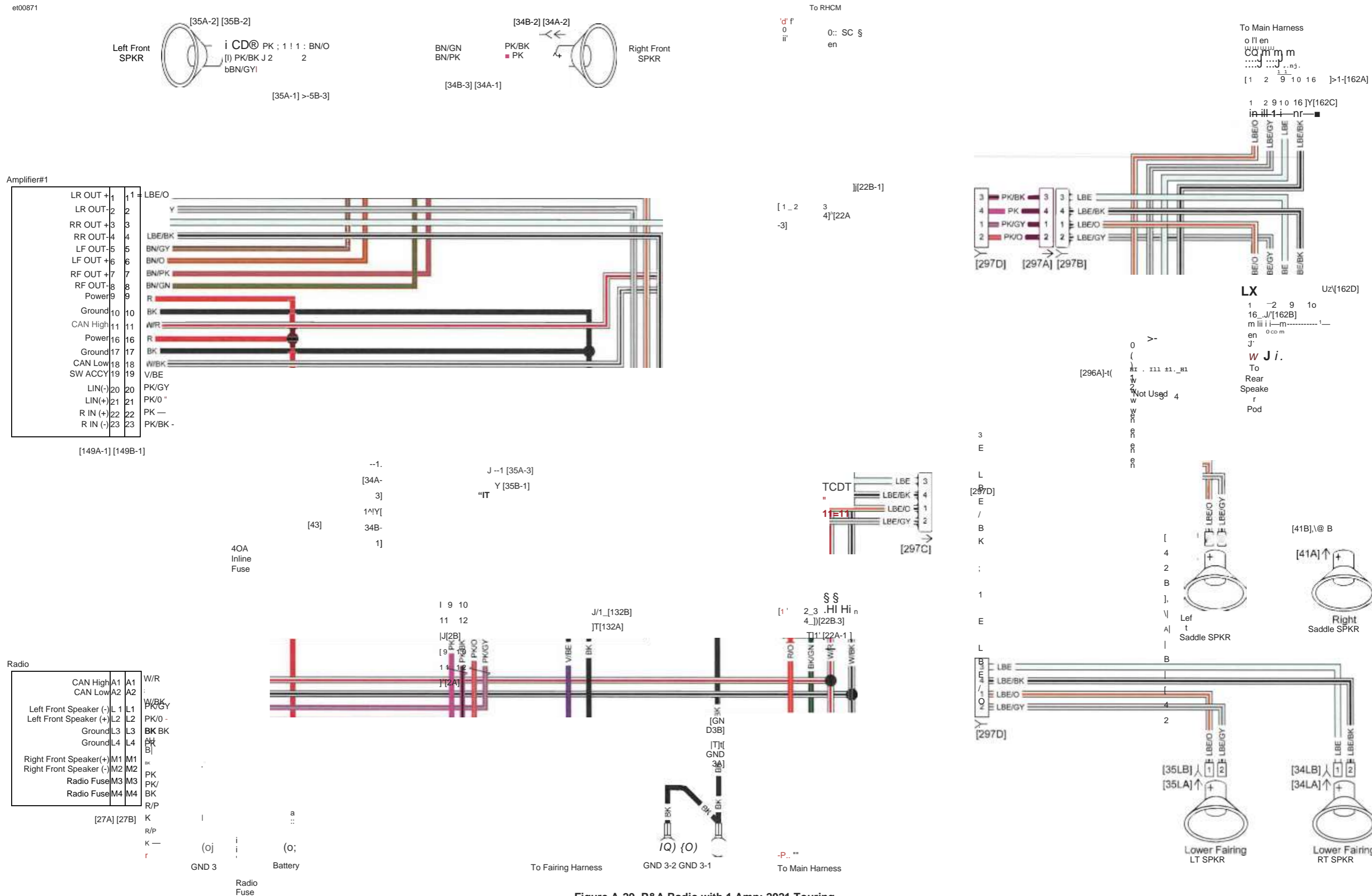


Figure A-29. P&A Radio with 1 Amp: 2021 Touring

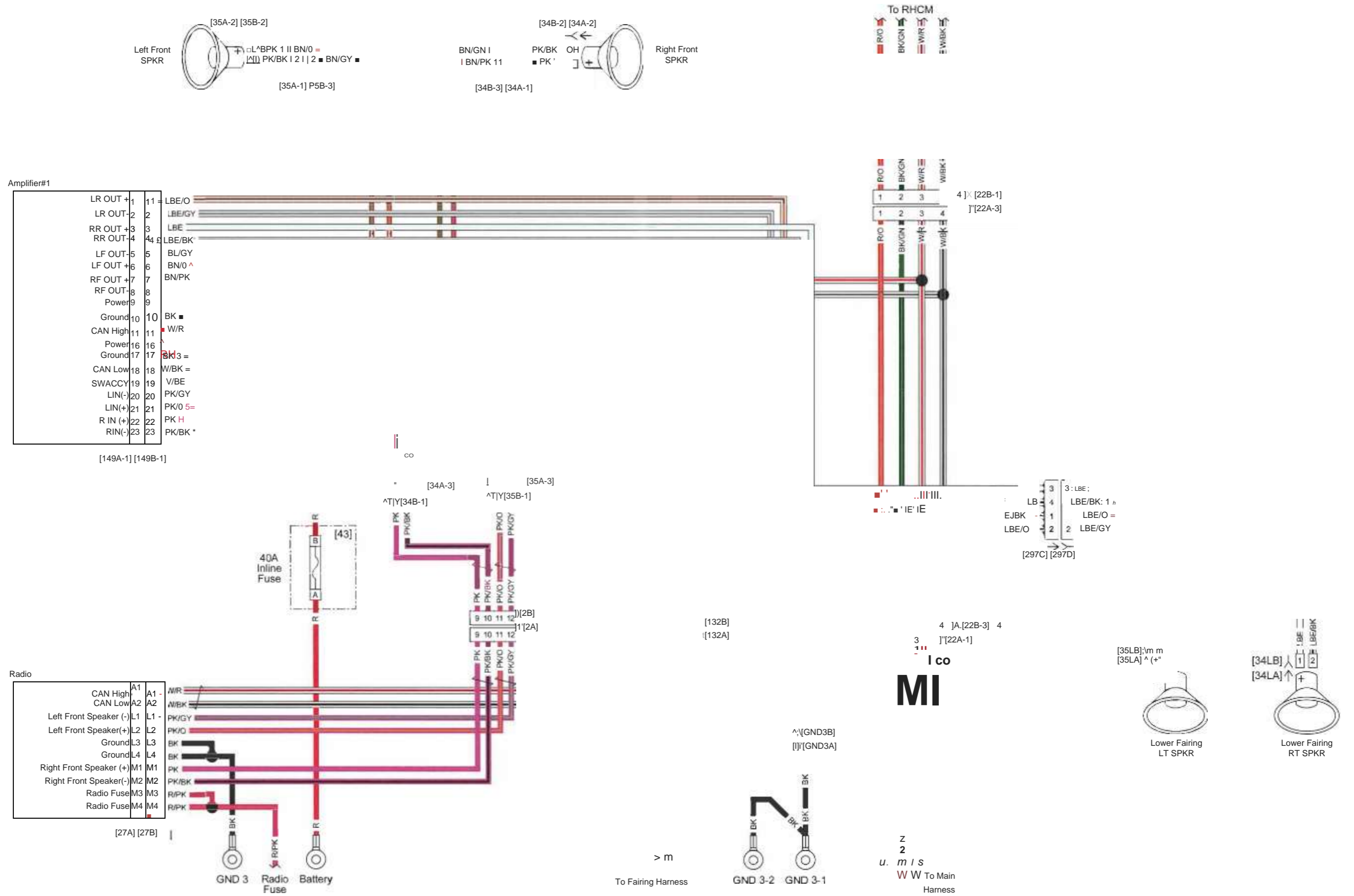
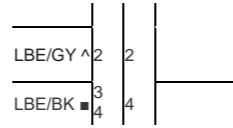
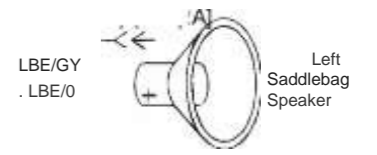
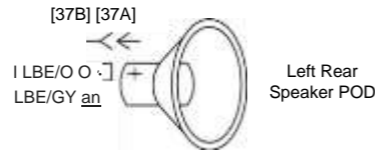


Figure A-30. P&A Radio with 2 Amps (1 of 2): 2021 Touring

10 -J [162A]  
10 Y [162C]  
1 2 9  
III III 11

!!k t i

nr



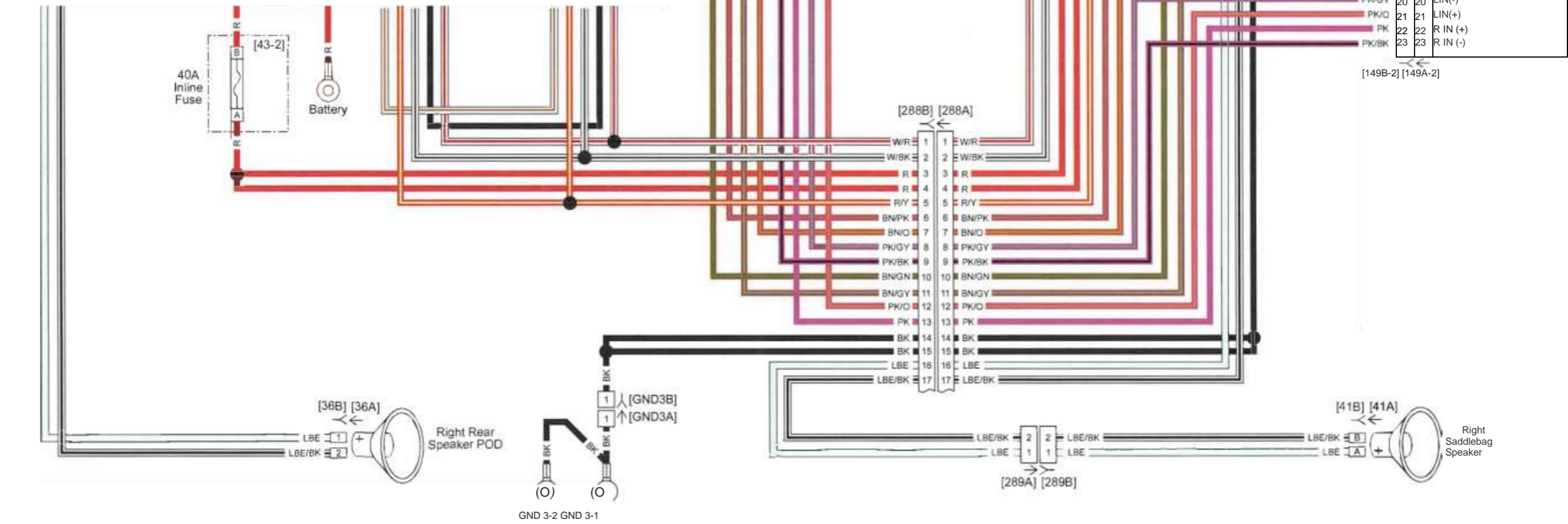
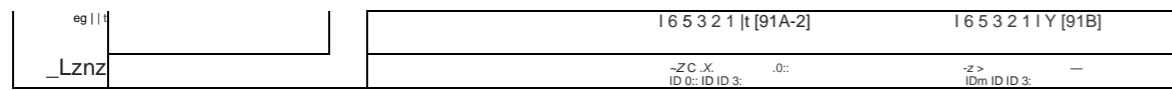
[296A] [296B]  
= LBE/O = 1 BN/O =  
LBE/GY r. 2 2 to BN/GY  
~ LBE : 3 s • BN/PK l  
LBE/BK ^ 4 BN/GN 3

[297B] [297A]

OV  
m J Cl  
ID ID

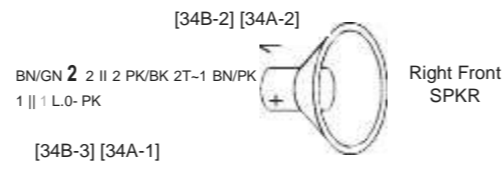
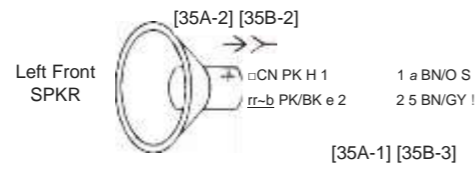
[.1 2 9 ii J  
ii 2 9 10 11 [162B]  
"H mr 11 il.

To Main



GND 3-2 GND 3-1

Figure A-31. P&A Radio with 2 Amps (1 of 2): 2021 Touring



Amplifier #1

|          |    |
|----------|----|
| LR OUT + | 1  |
| LR OUT - | 2  |
| RR OUT + | 3  |
| RR OUT - | 4  |
| LF OUT - | 5  |
| LF OUT + | 6  |
| RF OUT + | 7  |
| RF OUT - | 8  |
| Power    | 9  |
| Ground   | 10 |
| CAN High | 11 |
| Power    | 16 |
| Ground   | 17 |
| CAN Low  | 18 |
| SW ACCY  | 19 |
| LIN (-)  | 20 |
| LIN (+)  | 21 |
| R IN (+) | 22 |
| R IN (-) | 23 |

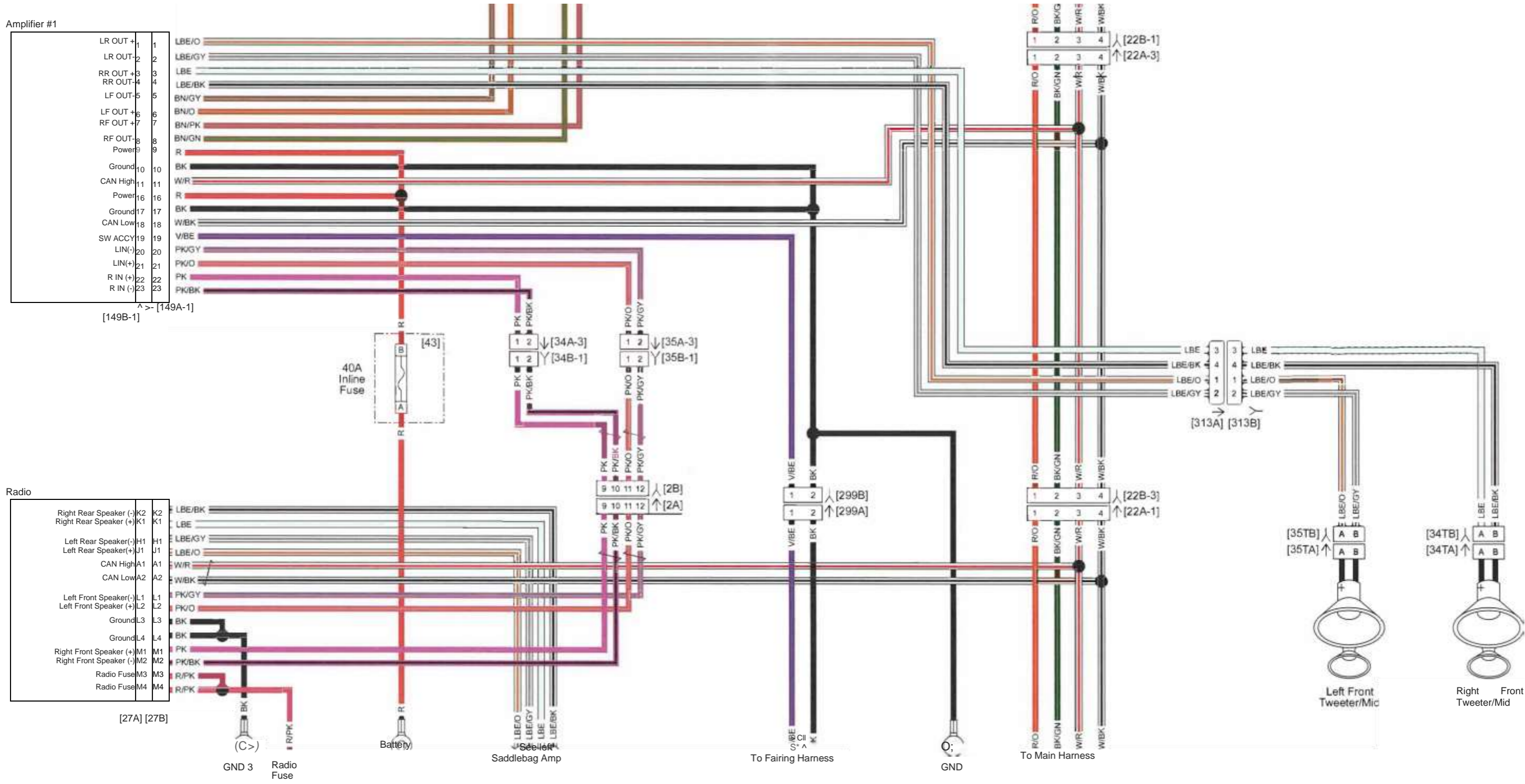


Figure A-32. P&A Radio with 4 Amps (1 of 4), Front Amp: 2021 Touring

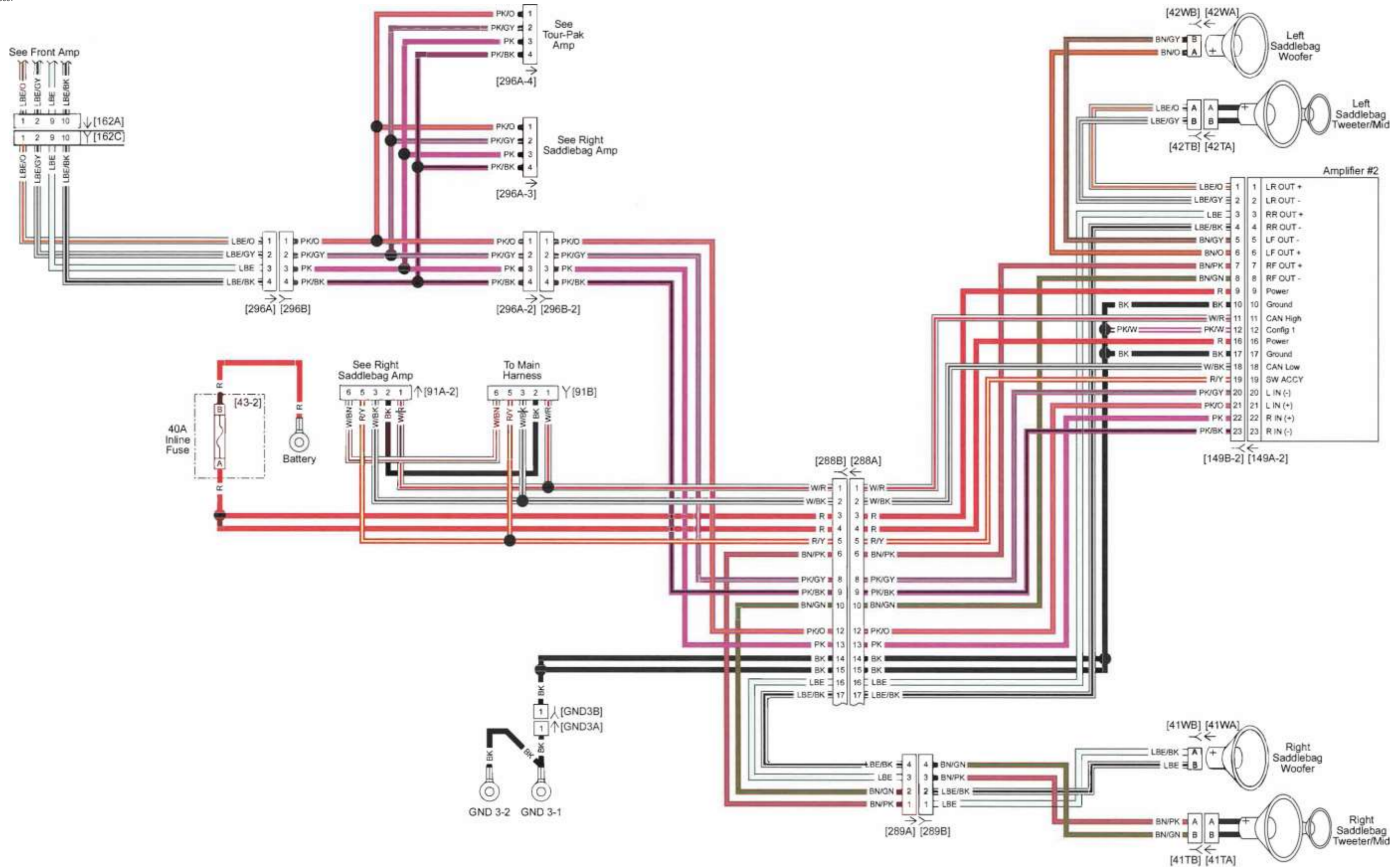
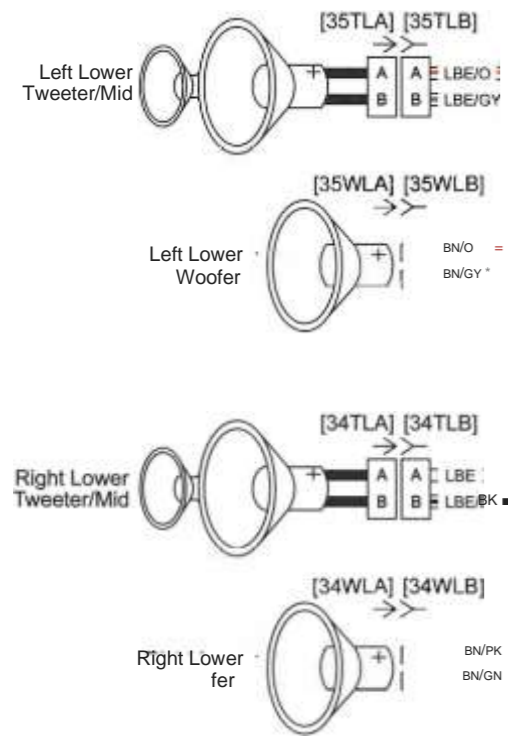


Figure A-33. P&A Radio with 4 Amps (2 of 4), Left Saddlebag Amp: 2021 Touring



[289B-2] [289A-2]

BN/O 5 BN/O  
 BN/GY 1 BN/GY  
 BN/PK 1 BN/PK  
 BN/GN 1 BN/GN

Amplifier #3

|         |    |    |          |
|---------|----|----|----------|
| LBE/O   | 1  | 1  | LR OUT + |
| LLBE/GV | 2  | 2  | LR OUT-  |
| LBE     | 3  | 3  | RR OUT + |
| LBE/BK  | 4  | 4  | RR OUT-  |
| BN/GY   | 5  | 5  | LF OUT-  |
| BN/O    | 6  | 6  | LF OUT + |
| BN/PK   | 7  | 7  | RF OUT + |
| BN/GN   | 8  | 8  | RF OUT-  |
| R       | 9  | 9  | Power    |
| BK      | 10 | 10 | Ground   |
| W/R     | 11 | 11 | CAN High |
| PK/W    | 13 | 13 | Config 2 |
| R       | 16 | 16 | Power    |
| BK in   | 17 | 17 | Ground   |
| W/BK    | 18 | 18 | CAN Low  |
| R/Y     | 19 | 19 | SWACCY   |
| PK/GY   | 20 | 20 | LIN(-)   |
| PK/O    | 21 | 21 | LIN(+)   |
| PK      | 22 | 22 | R IN(+)  |
| PK/BK   | 23 | 23 | R IN(-)  |

[149B-3] [149A-3]

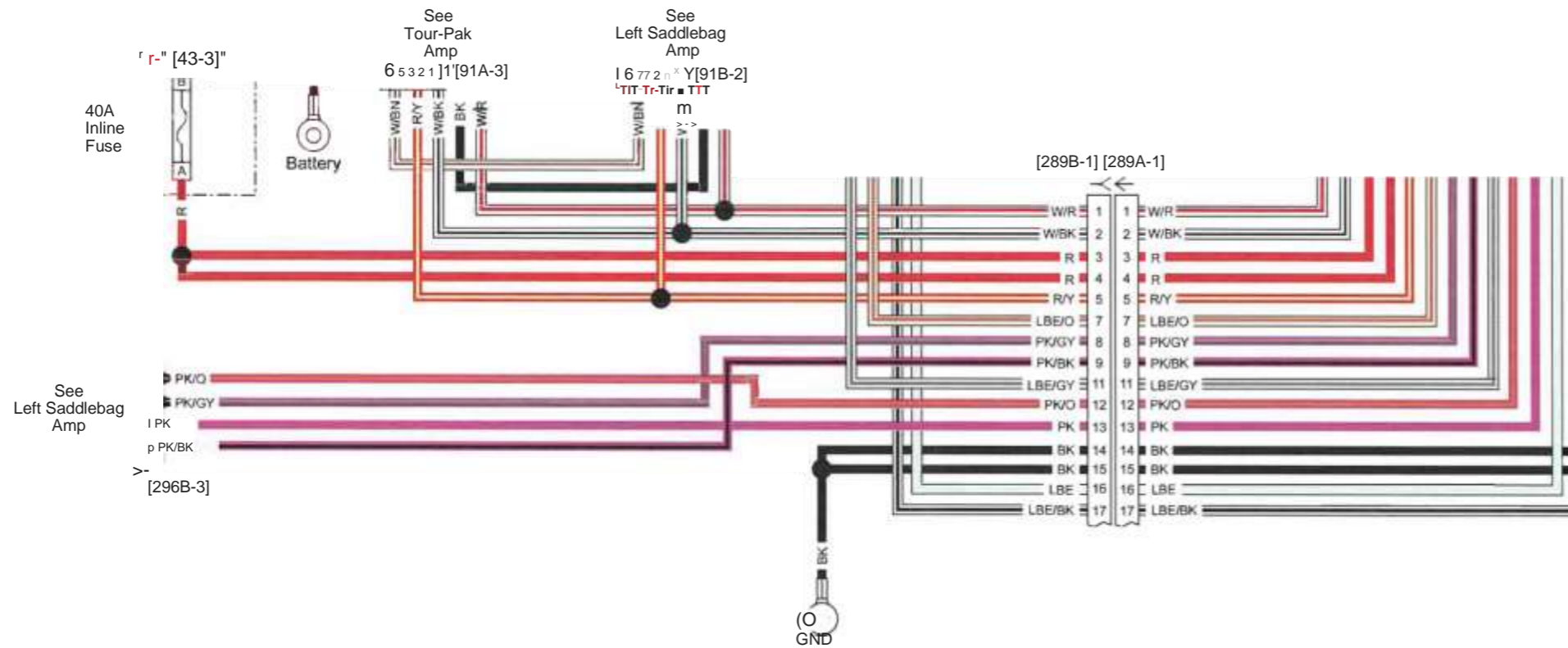


Figure A-34. P&A Radio with 4 Amps (3 of 4), Right Saddlebag Amp: 2021 Touring

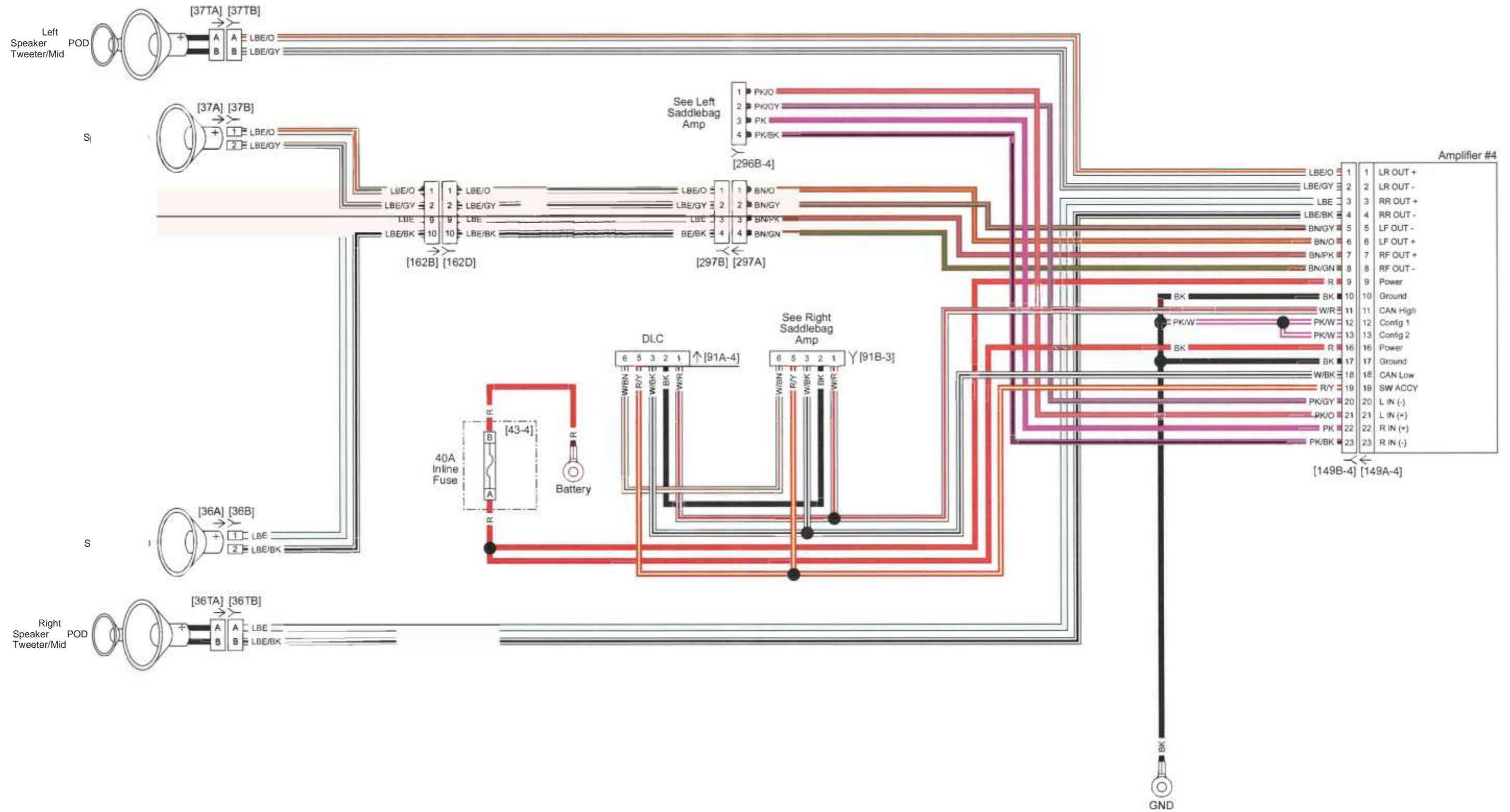


Figure A-35 . P&A Radio with 4Amps (4 of 4), Tour-Pak Amp: 2021 Touring





## GENERAL

### Function/Location

All vehicle connectors are identified by their function and location. Refer to Table A-2.

### Place and Color

The place (number of wire cavities of a connector housing) and color of the connector can also aid identification.

### Connector Number

On wiring diagrams and in service instructions, connectors are identified by a number in brackets.

### Repair Instructions

The repair instructions in Appendix B of the electrical diagnostic manual (EDM) are by connector type. Refer to Table A-2.

**Table A-2. Connector Locations**

| NO.    | DESCRIPTION                 | TYPE                                    | TERMINAL PROBE COLOR | LOCATION   |
|--------|-----------------------------|---|----------------------|--|
| [1]    | Fairing harness             | 16-way Molex MX 150 Sealed (BK)         | Gray                 | Inner fairing - right radio support bracket  |
| [2]    | Fairing harness             | 12-way Molex MX 150 Sealed (GY)         | Gray                 | Inner fairing - left radio support bracket   |
| [4]    | AUX devices                 | 4-way Molex MX150 (GY)                  | Gray                 | Under left side cover  |
| [5]    | Main fuse                   | 2-way Delphi 800 Metri-Pack Sealed (BK) | Red                  | Under left side cover  |
| [7]    | Rear fender lights harness  | 6-way Molex MX150 Sealed (BK)           | Gray                 | Top of rear fender (under seat)  |
| [12]   | Tour-Pak lights             | 6-way Molex MX150 Sealed (BK)           | Gray                 | Under seat in front of Tour-Pak  |
| [12-2] | Right side marker light     | 2-way Tyco 070 Multilock Unsealed (BK)  | Gray                 | Inside Tour-Pak  |
| [12-3] | Left side marker light      | 2-way Tyco 070 Multilock Unsealed (BK)  | Gray                 | Inside Tour-Pak  |
| [13]   | Fuel tank harness           | 4-way Molex MX150 Sealed (GY)           | Gray                 | Behind fuel tank (under seat)  |
| [18]   | Right rear turn signal      | 2-way Tyco 070 Multilock Unsealed (BK)  | Gray                 | Circuit board under tail lamp assembly   |
| [19]   | Left rear turn signal       | 2-way Tyco 070 Multilock Unsealed (BK)  | Gray                 | Circuit board under tail lamp assembly   |
| [20]   | Console harness             | 8-way Molex MX150 Sealed (BK)           | Gray                 | Under seat   |
| [22-1] | RHCM main harness           | 4-way JAE MX19 Sealed (BK)              | Yellow               | Inner fairing - under radio right side (with fairing) (except FLT)<br>Instrument nacelle (back of speedometer) (FLT models)<br>Inside headlamp nacelle (without fairing) |
|        | RHCM                        | 4-way JST JWPF Sealed (w)               | Light blue           | Inside RHCM housing  |
| [22-2] | RHCM main harness           | 2-way JAE MX19 Sealed (BK)              | Yellow               | Inner fairing - under radio right side (with fairing) (except FLT)<br>Instrument nacelle (back of speedometer) (FLT models)<br>Inside headlamp nacelle (without fairing) |
|        | RHCM                        | 2-way JST JWPF Sealed (w)               | Light blue           | Inside RHCM housing  |
| [24]   | LHCM main harness           | 4-way JAE MX19 Sealed (BK)              | Yellow               | Inner fairing - under radio left side (with fairing) (except FLT)<br>Instrument nacelle (back of speedometer) (FLT models)<br>Inside headlamp nacelle (without fairing)  |
|        | LHCM                        | 4-way JST JWPF Sealed (W)               | Light blue           | Inside LHCM housing  |
| [27]   | Radio                       | 48-way Molex CMC Sealed (BK)            | Breakout Box         | Inner fairing - back of radio (right side)   |
| [29]   | Position lamp (if equipped) | 2-way EPC (BK)                          | Gray                 | Inside headlamp nacelle  |

Table A-2 Connector Locations

| NO.            | DESCRIPTION  | TYPE   | TERMINAL PROBE COLOR | LOCATION   |
|----------------|--|--|----------------------|--|
| [31L]          | Left front turn signal/auxiliary lamp              | 4-way Tyco 070 Multilock Unsealed (BK) (without fairing) 4-way JAE MX19 Sealed (BK) (with fairing) | Gray<br>Yellow       | Inside headlamp nacelle (without fairing)<br>Inside left front turn signal/Aux lamp support (with fairing) (except FLT)<br>Inner fairing - lower right side (FLT)  |
| [31R]          | Right front turn signal/auxiliary lamp             | 6-way Tyco 070 Multilock Unsealed (BK) (without fairing) 4-way JAE MX19 Sealed (BK) (with fairing) | Gray<br>Yellow       | Inside headlamp nacelle (without fairing)<br>Inside right front turn signal/Aux lamp support (with fairing) (except FLT)<br>Inner fairing - lower right side (FLT) |
| [32]           | Front fender tip lamp jumper harness (if equipped) | 2-way Tyco 070 Multilock Unsealed (BK)   | Gray                 | Inner fairing -below upper for bracket (left side) (with fairing)<br>Inside headlamp nacelle (without fairing)   |
| [33]           | Ignition switch                                    | 2-way Delphi GT 150 3.5mm sealed (GY)  | Gray                 | Bottom of ignition switch (with fairing)<br>Under console (without fairing)  |
| [34-1]         | Right front speaker                                | 2-Way Molex MX150 (BK)   | Gray                 | Inner fairing (right speaker enclosure)  |
| [34-2]         | Right front speaker                                | Tyco Insulated Spade terminals (BK)  | Gray                 | Inner fairing (back of right speaker)  |
| [35-1]         | Left front speaker                                 | 2-Way Molex MX150 (BK)   | Gray                 | Inner fairing (left speaker enclosure)   |
| [35-2]         | Left front speaker                                 | Tyco Insulated Spade terminals (BK)  | Gray                 | Inner fairing (back of left speaker)   |
| [36+]<br>[36-] | Left rear speaker                                  | Tyco Insulated Spade terminals (BK)  | Gray                 | Inside left speaker POD (back of left speaker)   |
| [37+]<br>[37-] | Left rear speaker                                  | Tyco Insulated Spade terminals (BK)  | Gray                 | Inside right speaker POD (back of right speaker)   |
| [38]           | Headlamp   | 4-way Delphi 150 Metri-Pack (BK)   | Gray                 | Inner fairing back of headlamp   |
| [38HI]         | Headlamp high beam                                 | 2-way Tyco (GY)  | Gray                 | Inside headlamp nacelle  |
| [38LO]         | Headlamp low beam                                  | 2-way Tyco (BK)  | Gray                 | Inside headlamp nacelle  |
| [39]           | Speedometer (without fairing) IM (with fairing)    | 12-way Delphi Micro 64 Sealed (GY)   | Breakout Box         | Back of speedometer under console (without fairing) (except FLT)<br>Instrument nacelle (back of IM) (FLT models)<br>Inner fairing back of IM (with fairing)        |
| [41+]<br>[41-] | Right saddlebag speaker                            | Tyco Insulated Spade terminals (BK)  | Gray                 | Inside right saddlebag (back of speaker)   |
| [42+]<br>[42-] | Left saddlebag speaker                             | Tyco Insulated Spade terminals (BK)  | Gray                 | Inside left saddlebag (back of speaker)  |
| [45]           | Rear fender tip lamp (if equipped)                 | 2-way Tyco 070 Unsealed  | Gray                 | Circuit board under tail lamp assembly   |
| [47]           | Stator   | 3-way Dekko (BK)   | Green                | Bottom of voltage regulator (left side)  |
| [50]           | CB antenna cable                                   | 1-way AMP TCN  |                      | Inner fairing - back of CB module  |
| [51]           | Radio antenna cable                                | 1-way AMP TCN  |                      | Inner fairing - back of radio (left side)  |
| [52]           | Radio antenna cable to mast                        | 1-way AMP TCN  |                      | Inside of Tour-Pak   |
| [53]           | Rider headset                                      | 6-way Molex MX150 (BK)   | Gray                 | Under seat   |
| [64]           | Fuse block   | 24-way fargo fuse block unsealed (BK)  | Gray                 | Under left side cover  |
| [67]           | Accessory switch                                   | 4-way Tyco Mate-N-lok Unsealed (BK)  | Gray                 | Inside headlamp nacelle  |
| [73]           | Auxiliary/fog lamps                                | 2-way Delphi 280 Metri-Pack Sealed (BK)  | Purple               | Inside auxiliary/fog lamps   |
| [76]           | Passenger headset                                  | 7-way DIN (BK)   |                      | Below rear left speaker box  |
| [77]           | Voltage regulator                                  | 2-way Dekko (BK)   | Green                | Bottom of voltage regulator (right side)   |
| [78]           | ECM  | 81-way Delphi (BK)   | Breakout Box         | Under seat   |
| [79]           | CKP sensor   | 2-way Deutsch DTM Sealed (BK)  | Brown                | Rear of lower front frame crossmember  |
| [80]           | TMAP sensor  | 4-way MCON 1.2 Sealed  | Light blue           | Top of induction module  |
| [83]           | Ignition coil                                      | 3-way Delphi GT 150 3.5mm  | Gray                 | Bottom front of battery tray   |
| [84]           | Front fuel injector                                | 2-way Delphi GT 150 Sealed (BK)  | Purple               | Below fuel tank (left side)  |

Table A-2. Connector Locations

| NO.                | DESCRIPTION                                 | TYPE  | TERMINAL PROBE COLOR | LOCATION  |
|--------------------|---|---|----------------------|---|
| [85]               | Rear fuel injector                          | 2-way Delphi GT 150 Sealed (BK)   | Purple               | Below fuel tank (left side)   |
| [90]               | ET sensor                                   | 2-way MCON 1.2 Sealed   | Light blue           | Back of front cylinder (left side)  |
| [91B]              | DLC   | 6-Way Sumitomo OBD2 025 Sealed (R)  | Gray                 | Under left side cover   |
| [93]               | Tail lamp                                   | 4-way Tyco 070 Multilock Unsealed (BK)  | Gray                 | Circuit board under tail lamp assembly  |
| [94]               | Rear fender lights harness in circuit board | 6-way Tyco 070 Multilock Unsealed (BK)  | Gray                 | Circuit board under tail lamp assembly  |
| [95]               | Purge solenoid                              | 2-way Delphi 150 Metri-Pack Sealed (R)  | Gray                 | Under seat  |
| [97]               | Right cooling fan                           | 2-way Delphi 150 Metri-Pack Sealed (BK)   | Gray                 | Inside right lower fairing  |
| [105L]             | OE dash switch pack                         | 6-way Molex MX150 Sealed (BK)   | Gray                 | Behind switch cover (left side)   |
| [105R]             | P&A dash switch pack                        | 6-way Molex MX150 Sealed (BK)   | Gray                 | Behind switch cover (right side)  |
| [107]              | AAT sensor                                  | 2-way Molex MX64 Unsealed (BK)  | Light blue           | Steering head, left side  |
| [109]              | Auxiliary lamps switch (without fairing)    | 4-way Tyco Mate-N-Lok Unsealed (BK)   | Gray                 | Inside headlamp nacelle   |
| [111]              | Voltmeter                                   | 4-way Delphi GT 150 3.5mm Sealed (BK)   | Gray                 | Inner fairing (back of voltmeter)   |
| [111-2]            | Voltmeter jumper                            | 4-way JAEMX19 Sealed (BK)   | Yellow               | Inner fairing (marked with yellow spot tape)  |
| [117]              | Fuel gauge                                  | 4-way Tyco 040 Multilock unsealed (BK) (without fairing) 4-way Delphi GT 150 3.5mm Sealed (BK) (with fairing) | Gray                 | Inner fairing (back of fuel gauge) (with fairing)<br>Bottom fuel tank left side (without fairing) |
| [117-2]            | Fuel gauge jumper                           | 4-way JAEMX19 Sealed (BK)   | Yellow               | Inner fairing (marked with yellow spot tape)  |
| [120]              | Oil pressure switch                         | Push-on Right Angle Molded terminal (BK)  | Black                | Front right crankcase   |
| [121-1]<br>[121-2] | Rear brake switch                           | Push-on Molded terminals (BK)   | Red                  | Mid-chassis, lower right side between frame and exhaust pipe)                                     |
| [122-1]<br>[122-2] | Horn  | Flag terminals (BK)   | Red                  | Between cylinders (left side)   |
| [128]              | Starter solenoid                            | Delphi 56 Spade terminal (W)  | Red                  | Top of starter  |
| [131-1]<br>[131-2] | Neutral switch                              | Push-on Right Angle Molded terminals (BK)   |                      | Top of transmission (right side)  |
| [132]              | Power outlet                                | 2-way Tyco 070 Multilock Unsealed (BK)  | Gray                 | Inner fairing   |
| [132C]             | Power outlet                                | 2-way Delphi Unsealed (GY)  | Red                  | Inner fairing   |
| [133]              | JSS   | 3-way Molex MX 150 Sealed (BK)  | Gray                 | Rear of lower front frame crossmember   |
| [137]              | HO2S bank 2 sensor 1                        | 4-way Molex MX 150 Sealed (BK)  | Gray                 | Under right side cover  |
| [138]              | HO2S bank 1 sensor 1                        | 4-way Molex MX 150 Sealed (GY)  | Gray                 | Under right side cover  |
| [139]              | Oil pressure sender                         | 3-way Delphi GT 150 3.5mm Sealed  | Gray                 | Front right crankcase   |
| [141]              | Fuel pump and fuel level sender             | 4-way Delphi GT 280 Sealed (BK)   | Gray                 | Under console on top of fuel tank canopy  |
| [142]              | Security siren                              | 3-way Delphi GT 150 Sealed (BK)   | Gray                 | Under left side cover   |
| [143]              | Front fender tip lamp (if equipped)         | 2-way Tyco 070 Multilock Unsealed (BK)  | Gray                 | Under front fender tip lamp bracket   |
| [149-1]            | Audio amplifier 1                           | 23-way Tyco AMPSEAL Sealed (BK)   | Black                | Under fairing above radio   |
| [149-2]            | Audio amplifier 2                           | 23-way Tyco AMPSEAL Sealed (BK)   | Black                | Inside left saddlebag   |

Table A-2. Connector Locations

| NO.     | DESCRIPTION                     | TYPE  | TERMINAL PROBE COLOR | LOCATION   |
|---------|---------------------------------|---|----------------------|--|
| [162]   | Rear audio                      | 6-way Molex MX150 (BK)<br>(without Tour-Pak)<br>16-way Molex MX150 (BK)<br>(with Tour-Pak)                | Gray                 | Inner fairing - above radio (FLHX/S, FLT)<br>Under seat just in front of Tour-Pak (FLHT)   |
| [166]   | ABS module                      | 26-way Bosch BTC Sealed (BK)  | Breakout Box         | Under right side cover   |
| [167]   | Front WSS                       | 2-way Delphi 150 Metri-Pack Sealed (BK) (with fairing)<br>2-way Deutsch DTM Sealed (BK) (without fairing) | Gray<br>Brown        | Just below upper fork bracket right side (with fairing)<br>Inside headlamp nacelle (without fairing)   |
| [168]   | Rear WSS                        | 2-way Delphi 150 Metri-Pack Sealed (BK)   | Gray                 | Under right side cover   |
| [184]   | CB module                       | 12-way Molex MX150 Sealed (BK)  | Gray                 | Inner fairing - left side of radio   |
| [189]   | Heated handgrip to main harness | 2-way Tyco 040 multilock Unsealed (BK)  | Gray                 | Inner fairing - under radio right side (with fairing) (except FLT)<br>Instrument nacelle (back of IM) (FLT models)   |
| [193]   | GPS antenna                     |   |                      | Inner fairing- left side of radio  |
| [203FA] | ACR (front)                     | 2-way Tyco Superseal 1.5 Sealed   | Gray                 | Bracket attached to the throttle body  |
| [203RA] | ACR (rear)                      | 2-way Tyco Superseal 1.5 Sealed   | Gray                 | Bracket attached to the throttle body  |
| [204]   | TGS harness                     | 6-way JST JWPF Sealed   | Light blue           | Inner fairing - right side below radio (with fairing) (except FLT)<br>Instrument nacelle (back of IM) (FLT models)<br>Inside headlamp nacelle - fork stem nut lock plate (without fairing) |
| [205]   | Chassis cooling fan switch      | 4-way Mate-N-Lock   | Gray                 | Inside headlamp nacelle (FLHR)<br>Under fuel tank taped to the harness (FLRT)  |
| [206]   | Heated handgrip interconnect    | 2-way Tyco 040 Unsealed   | Gray                 | Inside outer fairing, right side   |
| [209]   | Security antenna                | 2-way Molex MX64 Unsealed (BK)  | Light blue           | Under seat   |
| [211]   | TCA                             | 6-way Delphi GT 150 Sealed  | Gray                 | Right side of engine (induction module)  |
| [215]   | Left cooling fan                | 2-way Delphi 150 Metri-Pack Sealed (BK)   | Gray                 | Inside left lower fairing  |
| [225]   | Rider headset                   | 7-way DIN (BK)  |                      | Under Console  |
| [226]   | Rear lighting jumper harness    | 12-way Delphi Micro 64 Sealed (GY)  | Breakout Box         | Rear fender tip fascia module  |
| [232R]  | Right cooling fan jumper        | 2-way Molex MX150 Sealed (BK)   | Gray                 | Under voltage regulator  |
| [232L]  | Left cooling fan jumper         | 4-way Molex MX150 Sealed (BK)   | Gray                 | Under voltage regulator  |
| [235]   | Cooling pump                    | 3-way MCON 1.2 Sealed   | Light blue           |  |
| [236]   | ECT sensor                      | 2-way Delphi GT 150 3.5mm Sealed (BK)   | Gray                 | Inside left lower fairing  |
| [242]   | BCM                             | 48-way Molex CMC Sealed (BK)  | Breakout Box         | Under left side cover  |
| [243]   | P&A CAN                         | 4-way JAEMX19 Sealed (BK)   | Yellow               | Inner fairing next to left speaker enclosure   |
| [258]   | Power outlet                    | 2-way Tyco 070 Multilock Unsealed (BK)  | Gray                 | Inside Tour-Pak  |
| [259]   | BCM power                       | 1-way Delphi 800 Metri-Pack Sealed (BK)   | Red                  | Under left side cover  |
| [262]   | Rear lighting jumper harness    | 12-way Delphi Micro 64 Sealed (GY)  | Breakout Box         | Rear fender tip fascia module  |
| [280]   | P&A audio                       | 12-way Molex MX150 Sealed (GY)  | Gray                 | Inner fairing - above radio  |
| [281]   | Battery tender                  | 2-way overmold (BK)   |                      | Under left side cover  |

Table A-2. Connector Locations

| NO.               | DESCRIPTION            | TYPE                                    | TERMINAL PROBE COLOR | LOCATION                             |
|-------------------|------------------------|---|----------------------|--------------------------------------|
| [287]             | Tour-Pak lights        | 5-way Delphi 150 Metri-Pack             | Gray                 | Inside Tour-Pak                      |
| [288]             | Left saddlebag         | 12-way Deutsch DT Sealed (BK)           | Black                | Inside left saddlebag                |
| [296]             | Speaker interconnect   | 4-way Molex MX150 (BK)                  | Gray                 | Under seat just in front of Tour-Pak |
| [297]             | Speaker interconnect   | 4-way Molex MX150 (BK)                  | Gray                 | Under seat just in front of Tour-Pak |
| [298]             | Right saddlebag        | 2-way Molex MX150 (BK)                  | Gray                 | Inside right saddlebag               |
| [299]             | P&A accessory power    | 2-way Tyco 070 Multilock Un-sealed (BK) | Gray                 | Inner fairing                        |
| [315]             | Front knock sensor     | 2-way KOSTAL MLK 1.2                    | Light blue           | Under fuel tank                      |
| [316]             | Rear knock sensor      | 2-way KOSTAL MLK 1.2                    | Light blue           | Under fuel tank                      |
| [317]             | Oil cooling fan        | 2-way Delphi Metr Pack 150              | Gray                 |                                      |
| [318]             | Chassis cooling fan    | 2-way Delphi Metr Pack 150              | Gray                 | Under seat                           |
| [319]             | Terminating resistor   | 2-Way Delphi GT 150                     | Gray                 | Right side cover                     |
| [325]             | P&A accessory          | 3-way Molex MX150                       | Gray                 | Right side cover                     |
| [333]             | IMU                    | 4-way Amp MQS (BK)                      | Yellow               | Beside the EHCU                      |
| [339]             | TCU                    | 6-way Molex MX150 (BK)                  | Gray                 | Behind the fairing                   |
| [340]             | HO2S bank 1 sensor 2   | 4-way Molex MX 150 Sealed               | Gray                 | Under right side cover               |
| [GND1]            | Right side ground stud | Ring terminals                          |                      | Under seat                           |
| [GND2]<br>[GND2A] | Left side ground stud  | Ring terminals                          |                      | Under seat                           |
| [GND3]            | Fork bracket ground    | 1-way Push On Molded terminal (BK)      |                      | Steering head, left side             |

CONNECTOR END VIEWS

Table A-3. Fairing Harness [1]

| TERMINAL | WIRE COLOR | CIRCUIT DESCRIPTION          |
|----------|------------|------------------------------|
| 1        | W/GY       | Run/stop switch input (FLH)  |
| 2        | W/R        | CAN high                     |
| 3        | W/BK       | CAN low                      |
| 4        | R/O        | Battery fuse                 |
| 5        | BK/GN      | Ground                       |
| 6        | -          | N/C                          |
| 7        | W/Y        | Fuel level (FLH)             |
|          | V/W        | HD-Link output (FLT)         |
| 8        | BE/W       | High beam headlamp           |
| 9        | BE/Y       | Low beam headlamp            |
| 10       | BE         | Running lights power         |
| 11       | BE/O       | Right front turn signal      |
| 12       | BE/PK      | Left front turn signal       |
| 13       | BE/BK      | Running/position light power |
| 14       | -          | N/C                          |
| 15       | -          | N/C                          |
| 16       | R/Y        | Accessory power (FLT)        |

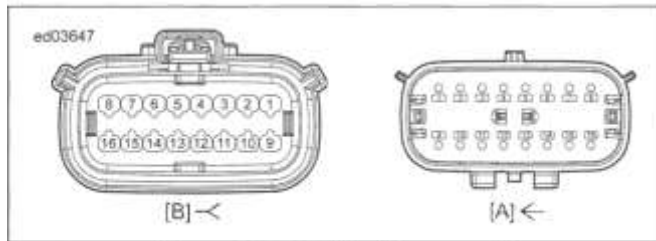


Figure A-34. Fairing Harness [1]

Table A-4. Fairing Harness [2]

| TERMINAL | WIRE COLOR | CIRCUIT DESCRIPTION     |
|----------|------------|-------------------------|
| 1        | -          | N/C                     |
| 2        | V/BE       | P&A relay power         |
| 3        | BK         | Ground                  |
| 4        | W/R        | CAN high (FLT)          |
| 5        | W/BK       | CAN low (FLT)           |
| 6        | -          | N/C                     |
| 7        | -          | N/C                     |
| 8        | -          | N/C                     |
| 9        | PK         | Speaker right front (+) |
| 10       | PK/BK      | Speaker right front (-) |
| 11       | PK/O       | Speaker left front (+)  |
| 12       | PK/GY      | Speaker left front (-)  |

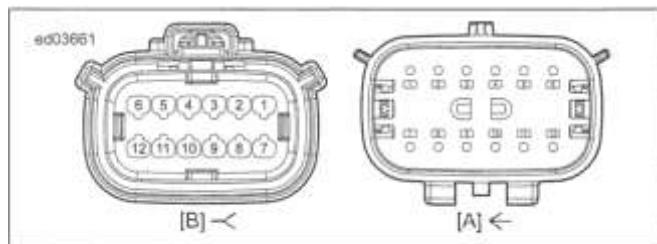


Figure A-35. Fairing Harness [2]

Table A-5. AUX Devices [4]

| TERMINAL | WIRE COLOR | CIRCUIT DESCRIPTION |
|----------|------------|---------------------|
| 1        | LBE/GN     | OE switch output 2  |
| 2        | LBE/Y      | P&A switch output 1 |
| 3        | LBE/W      | P&A switch output 2 |
| 4        | BK         | Ground              |

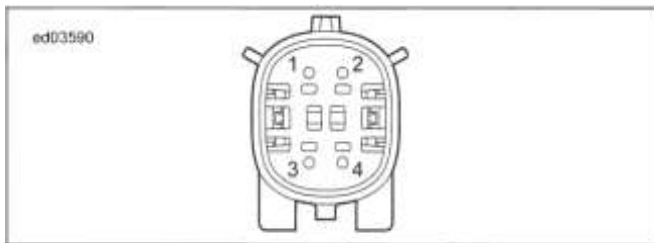


Figure A-36. P&A Accessory [4]

Table A-6. Main Fuse [5]

| TERMINAL | WIRECOLOR | CIRCUIT DESCRIPTION |
|----------|-----------|---------------------|
| A        | R         | Battery             |
| B        | R         | Main fuse           |

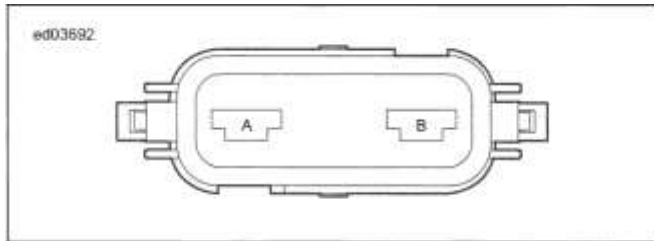


Figure A-37. Main Fuse [5]

Table A-7. Rear Lighting [7]

| TERMINAL | WIRECOLOR | CIRCUIT DESCRIPTION          |
|----------|-----------|------------------------------|
| 1        | RN        | Accessory power              |
| 2        | BE/BN     | Right rear turn signal       |
| 3        | BE        | Running/position light power |
| 4        | BE/R      | Brake light power            |
| 5        | BEN       | Left rear turn signal        |
| 6        | BK        | Ground                       |

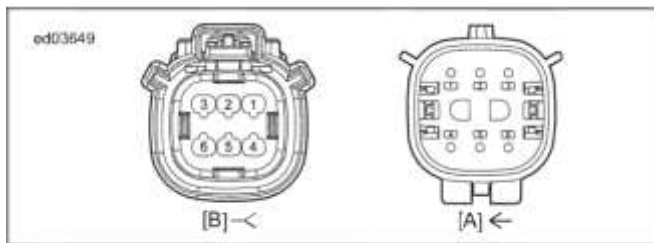


Figure A-38. Rear Lighting [7]

Table A-8. Tour-Pak Lights [12]

| TERMINAL | WIRECOLOR | CIRCUIT DESCRIPTION          |
|----------|-----------|------------------------------|
| 1        | V/BE      | P&A relay power              |
| 2        | BE/BN     | Right rear turn signal       |
| 3        | BE        | Running/position light power |
| 4        | BE/R      | Brake light power            |
| 5        | BEN       | Left rear turn signal        |
| 6        | BK        | Ground                       |

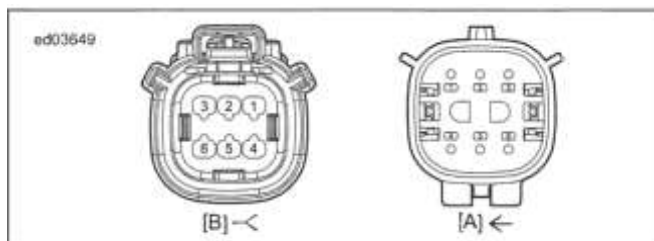


Figure A-39. Tour-Pak Lights [12]

Table A-9. Right Side Marker Lights [12-2B]

| TERMINAL | WIRECOLOR | CIRCUIT DESCRIPTION |
|----------|-----------|---------------------|
| 1        | V/BE      | P&A relay power     |
| 2        | BK        | Ground              |

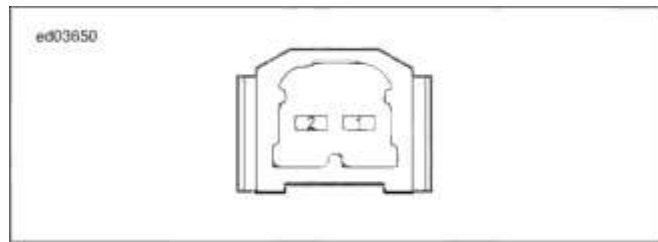


Figure A-40. Right Side Marker Lights [12-2B]

Table A-10. Left Side Marker Lights [12-3B]

| TERMINAL | WIRECOLOR | CIRCUIT DESCRIPTION |
|----------|-----------|---------------------|
| 1        | V/BE      | P&A relay power     |
| 2        | BK        | Ground              |

ed03650

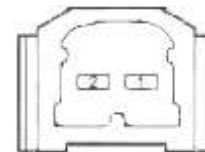


Figure A-41. Left Side Marker Lights [12-3B]

Table A-11. Fuel Tank Harness [13]

| TERMINAL | WIRECOLOR | CIRCUIT DESCRIPTION |
|----------|-----------|---------------------|
| 1        | R/BN      | Fuel pump power     |
| 2        | W/Y       | Fuel level sender   |
| 3        | BK/GN     | Sender ground       |
| 4        | BK        | Pump ground         |

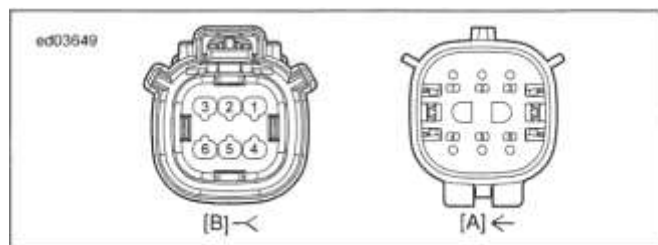


Figure A-42. Fuel Tank Harness [13]

Table A-12. Right Rear Turn Signal [18B]

| TERMINAL | WIRE COLOR | CIRCUIT DESCRIPTION    |
|----------|------------|------------------------|
| 1        | V/BN       | Right rear turn signal |
| 2        | BK         | Ground                 |

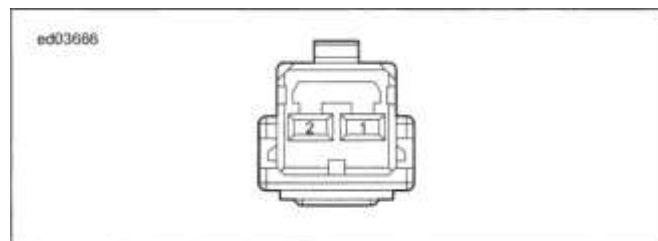


Figure A-43. Right Rear Turn Signal [18B]

| TERMINAL | WIRE COLOR | CIRCUIT DESCRIPTION   |
|----------|------------|-----------------------|
| 1        | V/BN       | Left rear turn signal |
| 2        | BK         | Ground                |

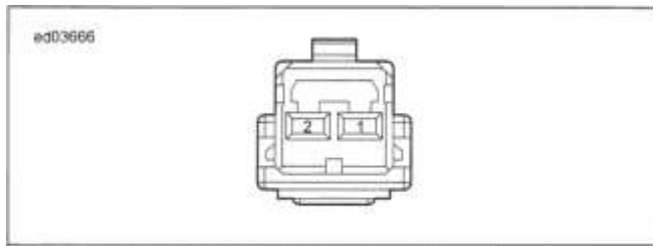


Figure A-44. Left Rear Turn Signal [19B]

Table A-14. Console Harness [20]

| TERMINAL | WIRE COLOR | CIRCUIT DESCRIPTION |
|----------|------------|---------------------|
| 1        | W/R        | CAN high            |
| 2        | BK/GN      | Ground              |
| 3        | W/BK       | CAN low             |
| 4        | W/Y        | Fuel level          |
| 5        | W/BE       | Ignition switch     |
| 6        | R/O        | Battery fuse        |
| 7        | R/BN       | Fuel pump power     |
| 8        | BK         | Ground              |

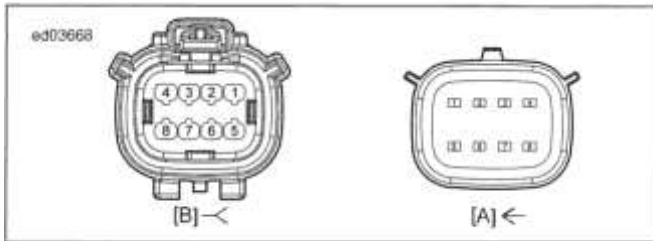


Figure A-45. Console Harness [20]

Table A-15. RHCM [22-1]

| TERMINAL | WIRE COLOR | CIRCUIT DESCRIPTION |
|----------|------------|---------------------|
| 1        | R/O        | Battery fuse        |
| 2        | BK/GN      | Ground              |
| 3        | W/R        | CAN high            |
| 4        | W/BK       | CAN low             |

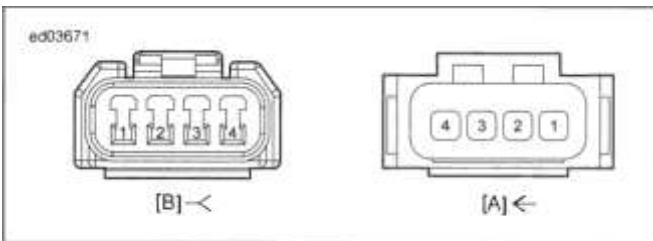


Figure A-46. RHCM [22-1]

Table A-16. RHCM [22D-1] (Inside Hand Controls)

| TERMINAL | WIRE COLOR | CIRCUIT DESCRIPTION |
|----------|------------|---------------------|
| 1        | R/O        | Battery fuse        |
| 2        | BK/GN      | Ground              |
| 3        | W/R        | CAN high            |
| 4        | W/BK       | CAN low             |

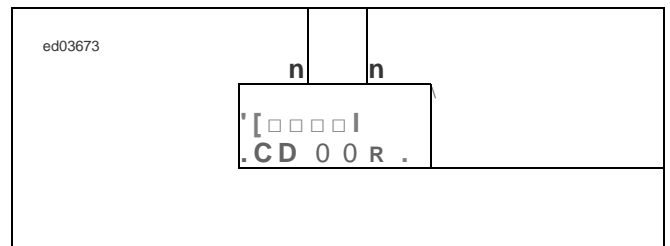


Figure A-47. RHCM [22D-1] (Inside Hand Controls)

Table A-17. RHCM [22-2]

| TERMINAL | WIRE COLOR | CIRCUIT DESCRIPTION |
|----------|------------|---------------------|
| 1        | W/GY       | Engine stop switch  |
| 2        | -          | N/C                 |

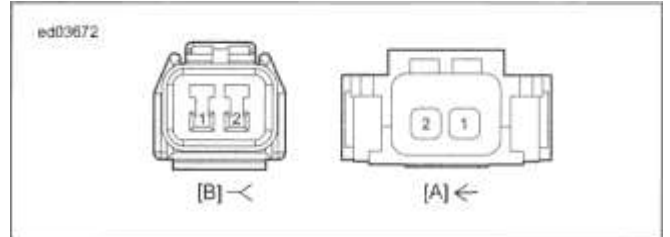


Figure A-48. RHCM [22-2]

Table A-18. RHCM [22D-2] (Inside Hand Controls)

| TERMINAL | WIRE COLOR | CIRCUIT DESCRIPTION |
|----------|------------|---------------------|
| 1        | W/GY       | Engine stop switch  |
| 2        | -          | N/C                 |



Figure A-49. RHCM [22D-2] (Inside Hand Controls)

Table A-19. LHCM [24]

| TERMINAL | WIRE COLOR | CIRCUIT DESCRIPTION |
|----------|------------|---------------------|
| 1        | R/O        | Battery fuse        |
| 2        | BK/GN      | Ground              |
| 3        | W/BK       | CAN low             |
| 4        | W/R        | CAN high            |

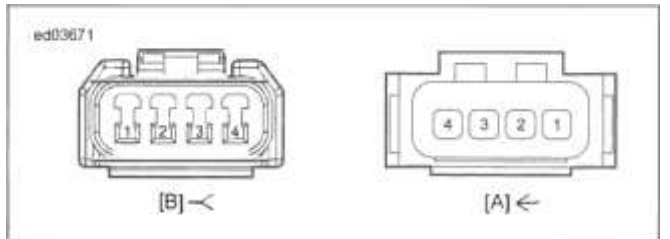


Figure A-50. LHCM [24]

Table A-20. LHCM [24D] (Inside Hand Controls)

| TERMINAL | WIRE COLOR | CIRCUIT DESCRIPTION |
|----------|------------|---------------------|
| 1        | R/O        | Battery fuse        |
| 2        | BK/GN      | Ground              |
| 3        | W/BK       | CAN low             |
| 4        | W/R        | CAN high            |

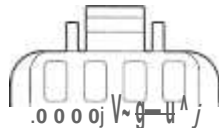


Figure A-51. LHCM [24D] (Inside Hand Controls)

Table A-21. Radio [27]

| TERMINAL | WIRE COLOR | CIRCUIT DESCRIPTION              |
|----------|------------|----------------------------------|
| A1       | W/R        | CAN high                         |
| A2       | W/BK       | CAN low                          |
| A3       | W/BN       | Aux CAN low                      |
| A4       | W/PK       | Aux CAN high                     |
| B1       | BK         | Ground                           |
| B2       | LBE/PK     | Rear switch input (FLH)          |
| B3       | -          | N/C                              |
| B4       | -          | N/C                              |
| C1       | R          | Microphone front (+)             |
| C2       | BK         | Microphone common (-)            |
| C3       | R          | Microphone sum out (+)           |
| C4       | -          | N/C                              |
| D1       | R/W        | Microphone rear (+) (FLH)        |
| D2       | BK/W       | Microphone shield (FLH)          |
| D3       | BK         | Microphone sum out (-)           |
| D4       | -          | N/C                              |
| E1       | LBE/W      | Headset left rear (+)            |
| E2       | LBEN       | Headset right rear (+)           |
| E3       | BK/PK      | Headset common (-)               |
| E4       | -          | N/C                              |
| F1       | PK/GN      | Headset front (+)                |
| F2       | PK/BE      | Headset right front (+)          |
| F3       | -          | N/C                              |
| F4       | LNE/BN     | Power external AMP power control |
| G1       | -          | N/C                              |
| G2       | -          | N/C                              |
| G3       | -          | N/C                              |
| G4       | -          | N/C                              |
| H1       | LBE/GY     | Speaker left rear (-)            |
| H2       | R          | Audio in 1 right(+)              |
| H3       | BK         | Audio in 1 shield/mono           |
| H4       | -          | N/C                              |
| J1       | LBE/O      | Speaker left rear(+)             |
| J2       | W          | Audio in 1 left mono(+)          |
| J3       | W          | Audio in 3 left mono (+)         |
| J4       | -          | N/C                              |
| K1       | LBE        | Speaker right rear (+)           |
| K2       | LBE/BK     | Speaker right rear (-)           |
| K3       | R          | Audio in 3 right (+)             |
| K4       | BK/Y       | Audio in 3 shield/mono (-)       |
| L1       | PK/GY      | Speaker left front (-)           |
| L2       | PK/O       | Speaker left front (+)           |
| L3       | BK         | Ground                           |
| L4       | BK         | Ground                           |
| M1       | PK         | Speaker right front (+)          |
| M2       | PK/BK      | Speaker right front (-)          |
| M3       | R/PK       | Radio fuse                       |
| M4       | R/PK       | Radio fuse                       |

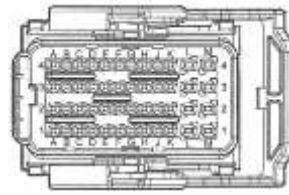


Figure A-52. Radio [27]

Table A-22. HDI Position Lamp [29] (With Fairing)

| TERMINAL | WIRE COLOR | CIRCUIT DESCRIPTION  |
|----------|------------|----------------------|
| 1        | BK         | Ground               |
| 2        | BE         | Running lights power |



Figure A-53. HDI Position Lamp [29] (With Fairing)

Table A-23. Position Lamp [29] (Without Fairing)

| TERMINAL | WIRE COLOR | CIRCUIT DESCRIPTION  |
|----------|------------|----------------------|
| 1        | BE         | Running lights power |
| 2        | BK         | Ground               |



Figure A-54. Position Lamp [29] (Without Fairing)

Table A-24. Left Front Turn Signal [31LA] (Without Fairing)

| TERMINAL | WIRE COLOR | CIRCUIT DESCRIPTION           |
|----------|------------|-------------------------------|
| 1        | BK         | Ground                        |
| 2        | BE/PK      | Left front turn signal        |
| 3        | BE         | Running lights                |
| 4        | BE/BK      | Front running/fog light power |

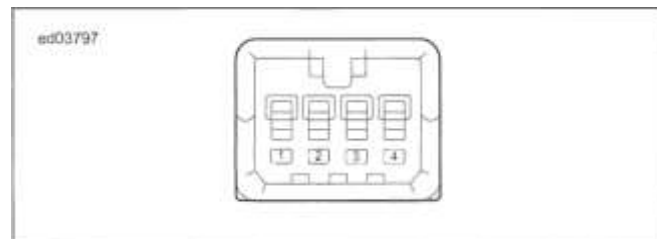


Figure A-55. Left Front Turn Signal [31 LA] (without Fairing)

Table A-25. Left Front Turn Signal [31 LB] (Without Fairing)

| TERMINAL | WIRE COLOR | CIRCUIT DESCRIPTION           |
|----------|------------|-------------------------------|
| 1        | BE         | Running lights power          |
| 2        | V          | Left turn signal              |
| 3        | BK         | Ground                        |
| 4        | GY/BK      | Front running/fog light power |



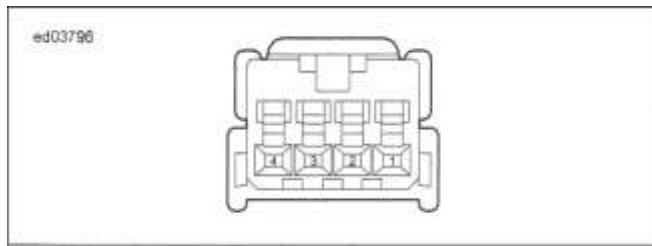


Figure A-56. Left Front Turn Signal [31LB] (Without Fairing)

Table A-26. Left Front Turn Signal [31L] (with Fairing)

| TERMINAL | WIRE COLOR | CIRCUIT DESCRIPTION           |
|----------|------------|-------------------------------|
| 1        | BE         | Running lights power          |
| 2        | BE/PK      | Left front turn signal        |
| 3        | BK         | Running lights                |
| 4        | BE/BK      | Front running/fog light power |

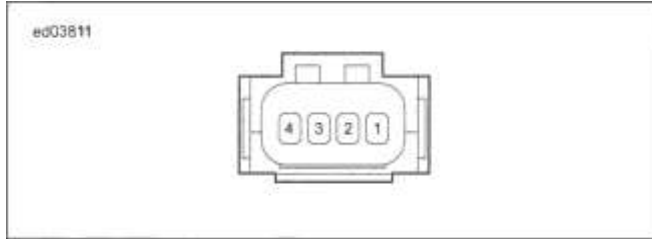


Figure A-57. Left Front Turn Signal [31 LA] (with Fairing)

Table A-27. Left Front Turn Signal [31LB] (With Fairing Except FLHX, FLT)

| TERMINAL | WIRE COLOR | CIRCUIT DESCRIPTION           |
|----------|------------|-------------------------------|
| 1        | BE         | Running lights power          |
| 2        | V          | Left turn signal              |
| 3        | BK         | Ground                        |
| 4        | GY/BK      | Front running/fog light power |

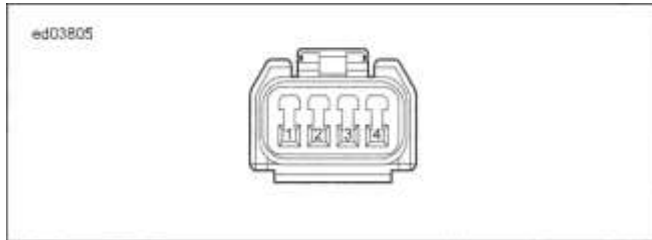


Figure A-58. Left Front Turn Signal [31LB] (With Fairing except FLHX, FLT)

Table A-28. Left Front Turn Signal [31LB] (FLHX, FLT)

| TERMINAL | WIRE COLOR | CIRCUIT DESCRIPTION  |
|----------|------------|----------------------|
| 1        | BE         | Running lights power |
| 2        | V/BN       | Left turn signal     |
| 3        | BK         | Ground               |
| 4        | -          | N/C                  |

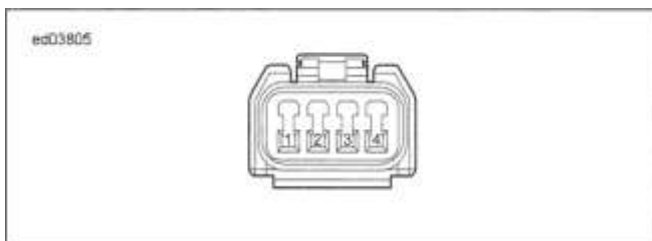


Figure A-59. Left Front Turn Signal [31LB] (FLHX, FLT)

Table A-29. Right Front Turn Signal [31RA] (without Fairing)

| TERMINAL | WIRE COLOR | CIRCUIT DESCRIPTION           |
|----------|------------|-------------------------------|
| 1        | BK         | Ground                        |
| 2        | BE/O       | Left front turn signal        |
| 3        | BE         | Running lights                |
| 4        | BE/BK      | Front running/fog light power |
| 5        | -          | N/C                           |
| 6        | -          | N/C                           |

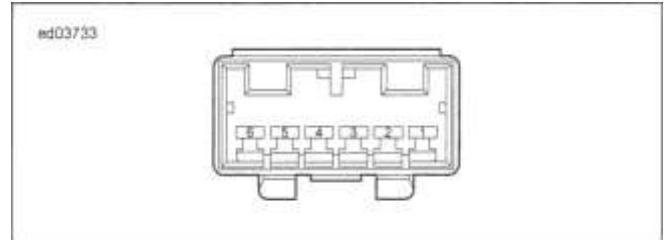


Figure A-60. Right Front Turn Signal [31RA] (without Fairing)

Table A-30. Right Front Turn Signal [31RB] (Without Fairing)

| TERMINAL | WIRE COLOR | CIRCUIT DESCRIPTION           |
|----------|------------|-------------------------------|
| 1        | BE         | Running lights power          |
| 2        | BN         | Right turn signal             |
| 3        | BK         | Ground                        |
| 4        | GY/BK      | Front running/fog light power |
| 5        | -          | N/C                           |
| 6        | -          | N/C                           |

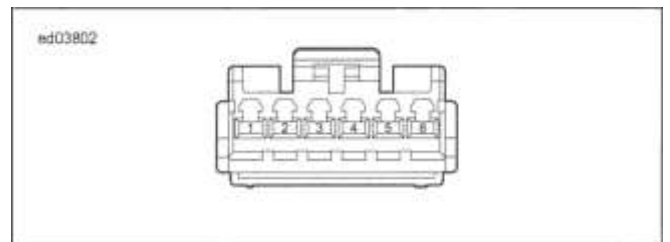


Figure A-61. Right Front Turn Signal [31RB] (Without Fairing)

Table A-31. Right Front Turn Signal [31RA] (With Fairing)

| TERMINAL | WIRE COLOR | CIRCUIT DESCRIPTION           |
|----------|------------|-------------------------------|
| 1        | BE         | Running lights power          |
| 2        | BE/O       | Right front turn signal       |
| 3        | BK         | Ground                        |
| 4        | BE/BK      | Front running/fog light power |

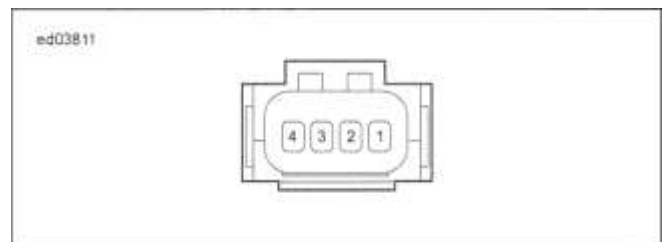


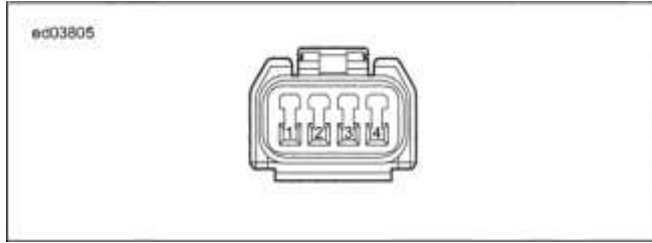
Figure A-62. Right Front Turn Signal [31RA] (with Fairing)

Table A-32. Right Front Turn Signal [31RB] (With Fairing  
Table A-36. Ignition Switch [33]  
Except FLHX, FLT)

| TERMINAL | WIRE COLOR | CIRCUIT DESCRIPTION  |
|----------|------------|----------------------|
| 1        | BE         | Running lights power |
| 2        | BN         | Right turn signal    |

**Table A-32. Right Front Turn Signal [31RB] (With Fairing Except FLHX,FLT)**

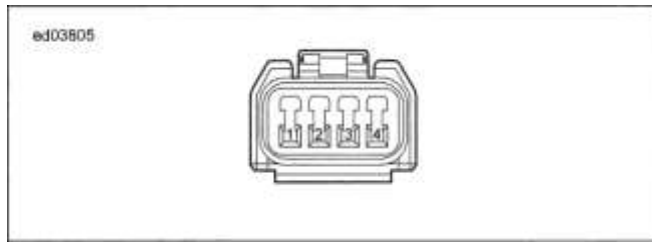
| TERMINAL | WIRE COLOR | CIRCUIT DESCRIPTION           |
|----------|------------|-------------------------------|
| 3        | BK         | Ground                        |
| 4        | GY/BK      | Front running/fog light power |



**Figure A-63. Right Front Turn Signal [31RB] (With Fairing Except FLHX,FLT)**

**Table A-33. Right Front Turn Signal [31RB] (FLHX, FLT)**

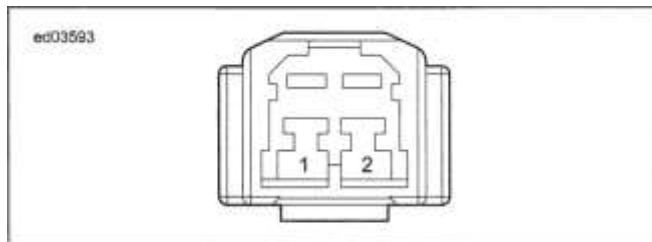
| TERMINAL | WIRE COLOR | CIRCUIT DESCRIPTION  |
|----------|------------|----------------------|
| 1        | BE         | Running lights power |
| 2        | V/BN       | Right turn signal    |
| 3        | BK         | Ground               |
| 4        | -          | N/C                  |



**Figure A-64. Right Front Turn Signal [31RB] (FLHX, FLT)**

**Table A-34. Front Fender Tip Lamp [32A]**

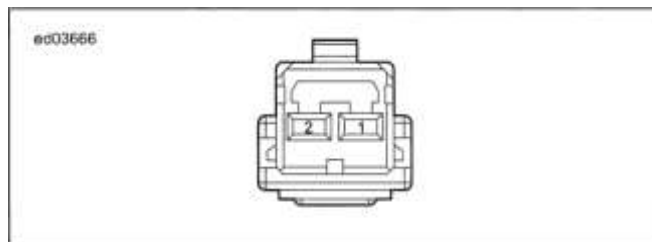
| TERMINAL | WIRE COLOR | CIRCUIT DESCRIPTION |
|----------|------------|---------------------|
| 1        | BE         | Accessory power     |
| 2        | BK         | Ground              |



**Figure A-65. Front Fender Tip Lamp [32A]**

**Table A-35. Front Fender Tip Lamp [32B]**

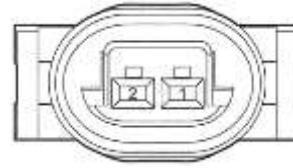
| TERMINAL | WIRECOLOR | CIRCUIT DESCRIPTION |
|----------|-----------|---------------------|
| 1        | O/W       | Accessory power     |
| 2        | BK        | Ground              |



**Figure A-66. Front Fender Tip Lamp [32B]**

| TERMINAL | WIRE COLOR | CIRCUIT DESCRIPTION |
|----------|------------|---------------------|
| 1        | BK/GN      | Ground              |
| 2        | W/BE       | Ignition switch     |

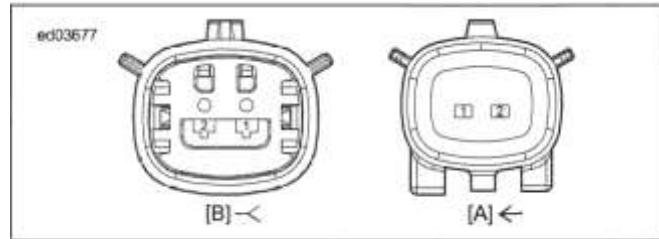
ed03686



**Figure A-67. Ignition Switch [33]**

**Table A-37. Right Front Speaker [34-1]**

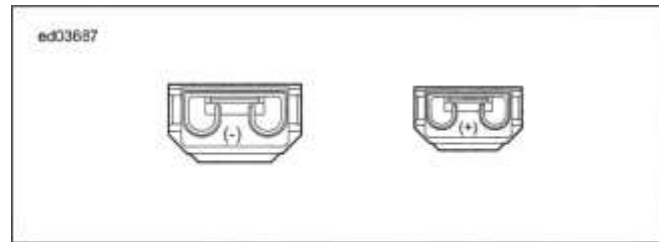
| TERMINAL | WIRE COLOR | CIRCUIT DESCRIPTION     |
|----------|------------|-------------------------|
| 1        | PK         | Right front speaker (+) |
| 2        | PK/BK      | Right front speaker (-) |



**Figure A-68. Right Front Speaker [34-1]**

**Table A-38. Right Front Speaker [34-2]**

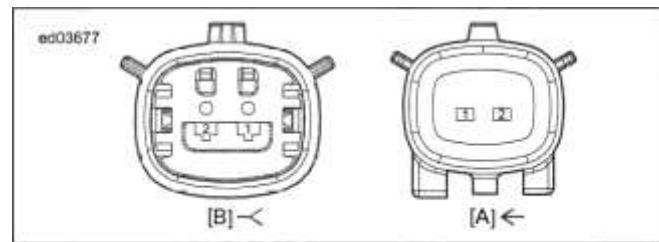
| TERMINAL | WIRE COLOR | CIRCUIT DESCRIPTION     |
|----------|------------|-------------------------|
| 1        | PK         | Right front speaker (+) |
| 2        | PK/BK      | Right front speaker (-) |



**Figure A-69. Right Front Speaker [34-2]**

**Table A-39. Left Front Speaker [35-1]**

| TERMINAL | WIRE COLOR | CIRCUIT DESCRIPTION    |
|----------|------------|------------------------|
| 1        | PK/O       | Left front speaker (+) |
| 2        | PK/BK      | Left front speaker (-) |



**Figure A-70. Left Front Speaker [35-1]**

**Table A-40. Left Front Speaker [35-2]**

| TERMINAL | WIRE COLOR | CIRCUIT DESCRIPTION    |
|----------|------------|------------------------|
| 1        | PK         | Left front speaker (+) |
| 2        | PK/BK      | Left front speaker (-) |

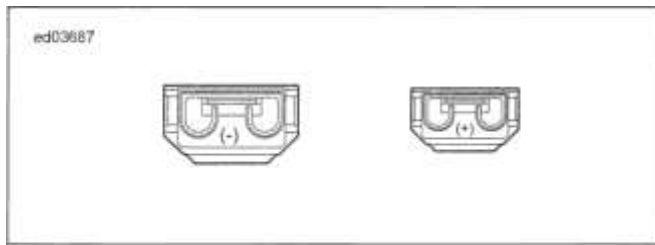


Figure A-71. Left Front Speaker [35-2]

Table A-41. Right Rear Speaker [36]

| TERMINAL | WIRE COLOR | CIRCUIT DESCRIPTION    |
|----------|------------|------------------------|
| 1        | LBE        | Right rear speaker (+) |
| 2        | LBE/BK     | Right rear speaker (-) |

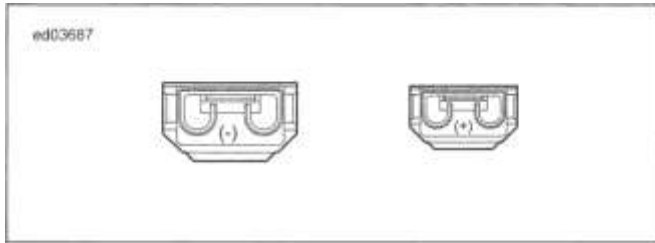


Figure A-72. Right Rear Speaker [36]

Table A-42. Left Rear Speaker [37]

| TERMINAL | WIRE COLOR | CIRCUIT DESCRIPTION   |
|----------|------------|-----------------------|
| 1        | LBE/O      | Left rear speaker (+) |
| 2        | LBE/GY     | Left rear speaker (-) |

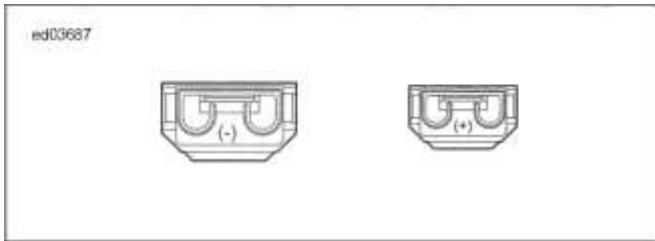


Figure A-73. Left Rear Speaker [37]

Table A-43. Headlamp [38A]

| TERMINAL | WIRE COLOR | CIRCUIT DESCRIPTION        |
|----------|------------|----------------------------|
| A        | BK         | Ground                     |
| B        | BE/Y       | Low beam power             |
| C        | BE/W       | High beam power            |
| D        | BE         | Running lights power (HDI) |

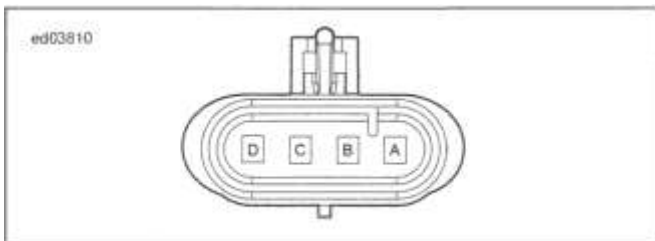


Figure A-74. Headlamp [38A]

Table A-44. Headlamp [38B]

| TERMINAL | WIRE COLOR | CIRCUIT DESCRIPTION        |
|----------|------------|----------------------------|
| A        | BK         | Ground                     |
| B        | BE/Y       | Low beam power             |
| C        | BE/W       | High beam power            |
| D        | BE         | Running lights power (FLH) |
|          | R/Y        | Accessory power (FLT)      |

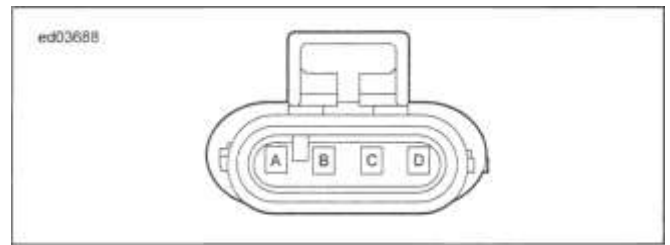


Figure A-75. Headlamp [38B]

Table A-45. Headlamp High Beam [38HI]

| TERMINAL | WIRE COLOR | CIRCUIT DESCRIPTION |
|----------|------------|---------------------|
| 1        | BK         | Ground              |
| 2        | BE/W       | High beam headlamp  |

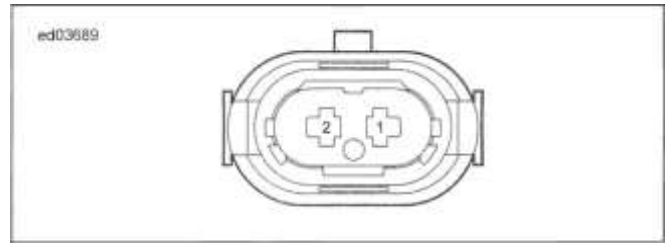


Figure A-76. Headlamp High Beam [38HI]

Table A-46. Headlamp Low Beam [38LO]

| TERMINAL | WIRE COLOR | CIRCUIT DESCRIPTION |
|----------|------------|---------------------|
| 1        | BK         | Ground              |
| 2        | BE/Y       | Low beam headlamp   |

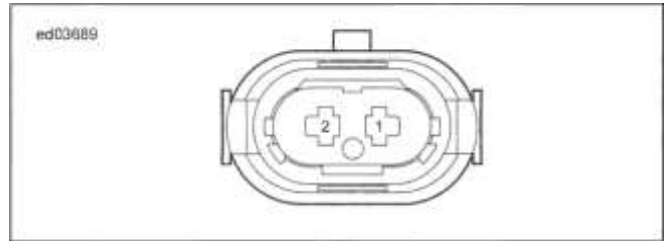


Figure A-77. Headlamp Low Beam [38LO]

Table A-47. IM [39] (with Fairing)

| TERMINAL | WIRE COLOR | CIRCUIT DESCRIPTION   |
|----------|------------|-----------------------|
| 1        | V/W        | HD-Link output        |
| 2        | W/R        | CAN high              |
| 3        | -          | N/C                   |
| 4        | TN/GN      | Parking brake (Trike) |
| 5        | R/O        | Battery fuse          |
| 6        | -          | N/C                   |
| 7        | BK/GN      | Ground                |
| 8        | W/BK       | CAN low               |
| 9        | W/Y        | Fuel level            |
| 10       | -          | N/C                   |
| 11       | -          | N/C                   |
| 12       | -          | N/C                   |

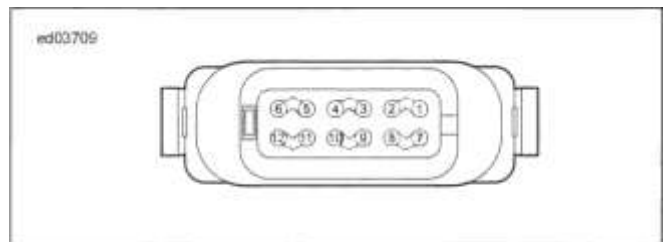


Figure A-78. IM [39] (with Fairing)

| TERMINAL | WIRE COLOR | CIRCUIT DESCRIPTION    |
|----------|------------|------------------------|
| 1        | W/O        | Oil pressure indicator |
| 2        | W/R        | CAN high               |
| 3        | -          | N/C                    |
| 4        | BE/W       | High beam indicator    |
| 5        | R/O        | Battery fuse           |
| 6        | W          | Neutral indicator      |
| 7        | BK/GN      | Ground                 |
| 8        | W/BK       | CAN low                |
| 9        | W/Y        | Fuel level             |
| 10       | BE/PK      | Left turn indicator    |
| 11       | -          | N/C                    |
| 12       | BE/O       | Right turn indicator   |

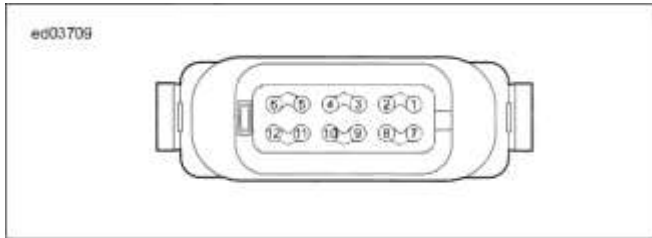


Figure A-79. Speedometer [39] (without Fairing)

Table A-49. Right Saddlebag Speaker [41]

| TERMINAL | WIRE COLOR | CIRCUIT DESCRIPTION         |
|----------|------------|-----------------------------|
| A        | LBE        | Right saddlebag speaker (+) |
| B        | LBE/BK     | Right saddlebag speaker(-)  |

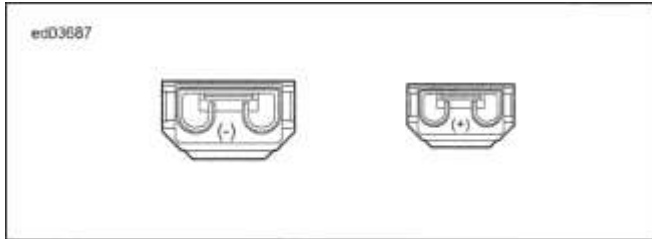


Figure A-80. Right Saddlebag Speaker [41]

Table A-50. Left Saddlebag Speaker [42]

| TERMINAL | WIRE COLOR | CIRCUIT DESCRIPTION        |
|----------|------------|----------------------------|
| A        | LBE/O      | Left saddlebag speaker (+) |
| B        | LBE/GY     | Left saddlebag speaker (-) |

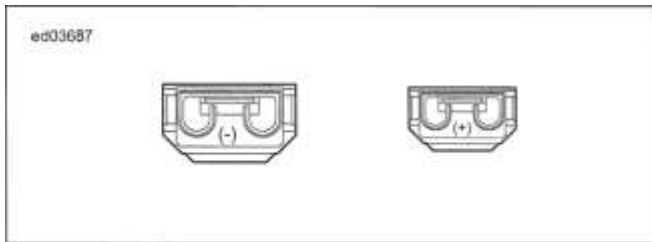


Figure A-81. Left Saddlebag Speaker [42]

Table A-51. Rear Fender Tip Lamp [45]

| TERMINAL | WIRE COLOR | CIRCUIT DESCRIPTION |
|----------|------------|---------------------|
| 1        | BK         | Running lights      |
| 2        | -          | N/C                 |
| 3        | BK         | Ground              |

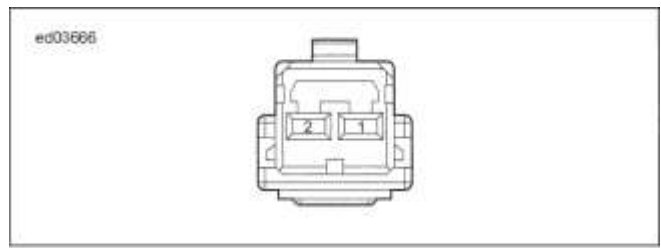


Figure A-82. Rear Fender Tip Lamp [45]

Table A-52. Stator [47]

| TERMINAL | WIRE COLOR | CIRCUIT DESCRIPTION |
|----------|------------|---------------------|
| 1        | BK         | Stator              |
| 1        | BK         | Stator              |
| 1        | BK         | Stator              |

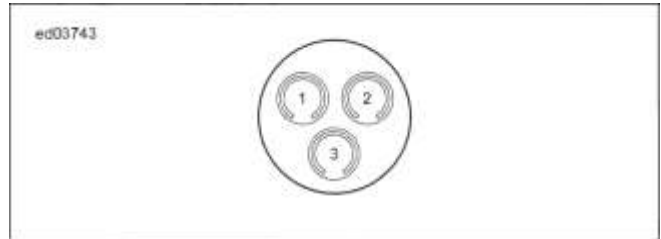


Figure A-83. Stator [47]

Table A-53. Rider Headset [53A]

| TERMINAL | WIRE COLOR | CIRCUIT DESCRIPTION     |
|----------|------------|-------------------------|
| 1        | PK/GN      | Headset left front (+)  |
| 2        | BK/PK      | Headset common (-)      |
| 3        | PK/BE      | Headset right front (+) |
| 4        | R          | Microphone front (+)    |
| 5        | BK         | Microphone common (-)   |
| 6        | BK/W       | Microphone shield (-)   |

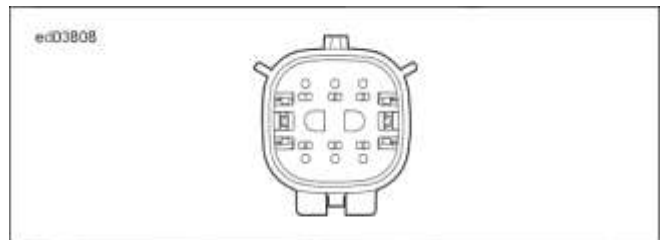


Figure A-84. Rider Headset [53A]

Table A-54. Rider Headset [53B]

| TERMINAL | WIRE COLOR | CIRCUIT DESCRIPTION     |
|----------|------------|-------------------------|
| 1        | PK/GN      | Headset left front (+)  |
| 2        | BK         | Headset common (-)      |
| 3        | PK/BE      | Headset right front (+) |
| 4        | R          | Microphone front (+)    |
| 5        | BK         | Microphone common (-)   |
| 6        | BK/W       | Microphone shield (-)   |

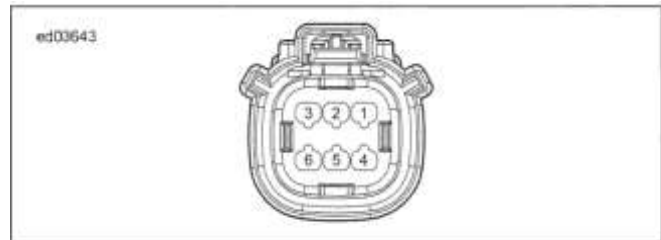


Figure A-85. Rider Headset [53B]

Table A-55. Fuse Block [64]

| TERMINAL | WIRE COLOR | CIRCUIT DESCRIPTION |
|----------|------------|---------------------|
| 1        | R          | Battery             |
| 2        | R/0        | Battery fuse        |
| 3        | V/GN       | System power fuse   |
| 4        | R/GN       | System power        |
| 5        | R          | Battery             |
| 6        | R/PK       | Radio fuse          |
| 7        | BK         | Spare               |
| 8        | -          | N/C                 |
| 9        | R          | Battery             |
| 10       | BN         | Cooling fuse        |
| 11       | R          | Battery             |
| 12       | R/BE       | P&A fuse            |
| 13       | BK         | Spare               |
| 14       | BK         | Spare               |
| 15       | BN         | Cooling fuse        |
| 16       | R/GN       | System power        |
| 17       | R/BE       | P&A fuse            |
| 18       | R/Y        | Accessory power     |
| 19       | -          | N/C                 |
| 20       | BK         | Spare               |
| 21       | BK         | Ground              |
| 22       | BN/BE      | Left cooling fan    |
| 23       | BK         | Ground              |
| 24       | VIBE       | P&A relay           |

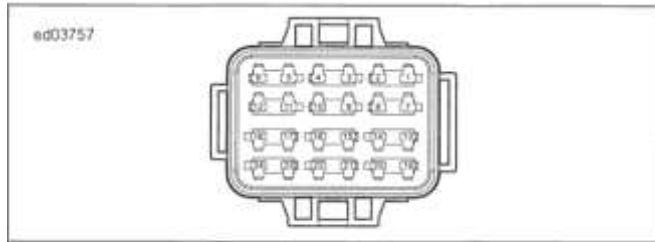


Figure A-86. Fuse Block [64]

Table A-56. Accessory Switch [67]

| TERMINAL | WIRE COLOR | CIRCUIT DESCRIPTION |
|----------|------------|---------------------|
| 1        | VIBE       | P&A relay           |
| 2        | -          | N/C                 |
| 3        | -          | N/C                 |
| 4        | LBE/GN     | P&A accessory       |

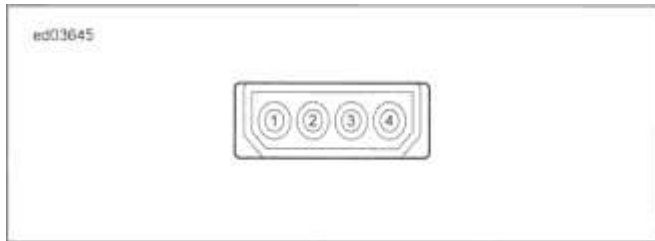


Table A-57. Auxiliary/Fog Lamps [73]

| TERMINAL | WIRE COLOR | CIRCUIT DESCRIPTION           |
|----------|------------|-------------------------------|
| A        | GY/BK      | Front running/fog light power |
| B        | BK         | Ground                        |

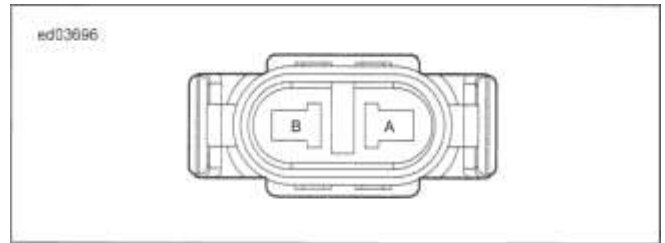


Figure A-88. Auxiliary/Fog Lamps [73]

Table A-58. Passenger Headset [76]

| TERMINAL | WIRE COLOR | CIRCUIT DESCRIPTION   |
|----------|------------|-----------------------|
| 1        | BK         | Microphone common (-) |
| 2        | BK         | Headset common (-)    |
| 3        | PK/BE      | Rear RT headset (+)   |
| 4        | R          | Rear microphone (+)   |
| 5        | PK/GN      | Rear LT headset (+)   |
| 6        | -          | N/C                   |
| 7        | -          | N/C                   |
| TAB      | BK/W       | Microphone shield     |



Figure A-89. Passenger Headset [76]

Table A-59. Voltage Regulator [77]

| TERMINAL | WIRE COLOR | CIRCUIT DESCRIPTION |
|----------|------------|---------------------|
| P        | R          | Battery             |
| N        | BK         | Ground              |

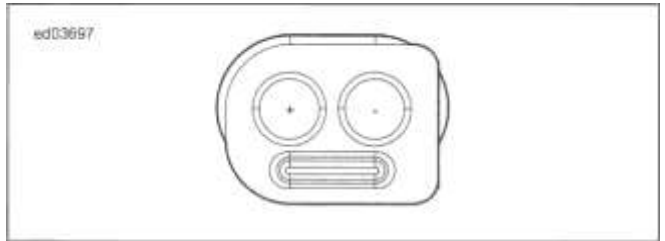


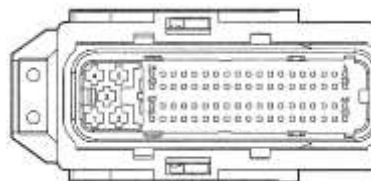
Figure A-90. Voltage Regulator [77]

**Table A-60. ECM [78]**

| TERMINAL | WIRE COLOR | CIRCUIT DESCRIPTION  |
|----------|------------|--|
| 1        | GY/BK      | Right cooling fan (if equipped)<br>Oil cooling fan (if equipped) |
| 2        | BK/GN      | Ground   |
| 3        | BK/GN      | Ground   |
| 4        | GN/BK      | Cooling fan left   |
| 5        | R/GN       | System power   |
| 6        | GN/Y       | Front fuel injector  |
| 7        | GY/Y       | Rear fuel injector   |
| 8        | LGN/R      | Rear ACR   |
| 9        | -          | N/C  |
| 10       | -          | N/C  |
| 11       | BK         | Crank position sensor  |
| 12       | -          | N/C  |
| 13       | -          | N/C  |
| 14       | BK/O       | HO2S ground bank 1 sensor 1                                      |
| 15       | -          | N/C  |
| 16       | LGN/BK     | Purge solenoid   |
| 17       | -          | N/C  |
| 18       | -          | N/C  |
| 19       | -          | N/C  |
| 20       | GY/O       | Throttle motor lo  |
| 21       | GN/O       | Throttle motor hi  |
| 22       | -          | N/C  |
| 23       | BK/PK      | HO2S ground bank 2 sensor 1                                      |
| 24       | GN/BE      | Front coil out   |
| 25       | LGN/R      | Front ACR  |
| 26       | GN/BN      | HO2S bank 1 sensor 2   |
| 27       | GY/N       | Throttle position sensor 2                                       |
| 28       | -          | N/C  |
| 29       | BK/W       | 5V sensor ground 1   |
| 30       | R          | Crank position sensor +  |
| 31       | -          | N/C  |
| 32       | W/O        | Oil pressure   |
| 33       | -          | N/C  |
| 34       | LGN/GY     | Jiffy stand  |
| 35       | -          | N/C  |
| 36       | BN/W       | Front knock sensor HI  |
| 37       | LGN/W      | Front knock sensor LO  |
| 38       | W/BK       | CAN low  |
| 39       | W/R        | CAN high   |
| 40       | -          | N/C  |
| 41       | GN/W       | Twist grip sensor 1  |
| 42       | GY/W       | Twist grip sensor 2  |
| 43       | GY/BE      | Rear coil out  |
| 44       | V/BK       | Chassis cooling fan control                                      |
| 45       | BNN        | Rear knock sensor HI   |
| 46       | LGNN       | Rear knock sensor LO   |
| 47       | GN/BN      | HO2S bank 1 sensor 1   |
| 48       | GY/BN      | HO2S bank 2 sensor 1   |
| 49       | GY/GN      | Coolant sensor   |
| 50       | -          | N/C  |
| 51       | -          | N/C  |
| 52       | GNN        | Throttle position sensor 1                                       |
| 53       | GY         | TMAP pressure in   |
| 54       | -          | N/C  |
| 55       | GN         | Engine temp sensor   |
| 56       | -          | N/C  |
| 57       | -          | N/C  |
| 58       | -          | N/C  |
| 59       | -          | N/C  |
| 60       | -          | N/C  |

**Table A-60. ECM [78]**

| TERMINAL | WIRE COLOR | CIRCUIT DESCRIPTION         |
|----------|------------|-----------------------------|
| 61       | -          | N/C                         |
| 62       | -          | N/C                         |
| 63       | BN/BK      | Coolant pump control        |
| 64       | -          | N/C                         |
| 65       | BK/W       | HO2S sensor ground          |
| 66       | R/GY       | 5V sensor power 2           |
| 67       | R/O        | 5A battery fuse             |
| 68       | -          | N/C                         |
| 69       | -          | N/C                         |
| 70       | R/W        | 5V sensor power 1           |
| 71       | W/N        | Air temperature             |
| 72       | GN/GY      | Intake air temperature      |
| 73       | -          | N/C                         |
| 74       | BK/GY      | 5V sensor ground 2          |
| 75       | -          | N/C                         |
| 76       | -          | N/C                         |
| 77       | -          | N/C                         |
| 78       | -          | N/C                         |
| 79       | BN/Y       | Chassis cooling fan switch  |
| 80       | BN/O       | HO2S heater bank 1 sensor 2 |
| 81       | -          | N/C                         |



**Figure A-91. ECM [78]**

**Table A-61. CKP Sensor [79]**

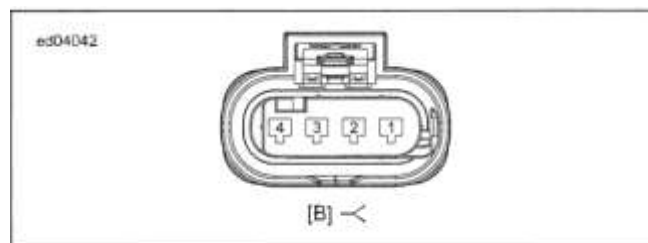
| TERMINAL | WIRE COLOR | CIRCUIT DESCRIPTION |
|----------|------------|---------------------|
| 1        | R          | CKP sensor high     |
| 2        | BK         | CKP sensor low      |



**Figure A-92. CKP Sensor [79]**

**Table A-62. TMAP [80]**

| TERMINAL | WIRE COLOR | CIRCUIT DESCRIPTION |
|----------|------------|---------------------|
| 1        | GY         | MAP input           |
| 2        | R/GY       | 5V sensor power 2   |
| 3        | GN/GY      | IAT                 |
| 4        | BK/GY      | 5V sensor ground 2  |



**Figure A-93. TMAP [80]**

| TERMINAL | WIRE COLOR | CIRCUIT DESCRIPTION |
|----------|------------|---------------------|
| A        | GY/BE      | Rear ignition coil  |
| B        | R/GN       | System power        |
| C        | GN/BE      | Front ignition coil |

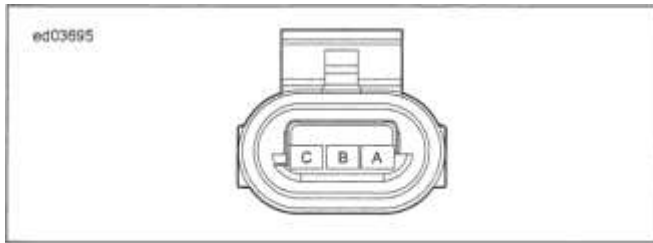


Figure A-94. Ignition Coil [83]

Table A-64. Front Fuel Injector [84]

| TERMINAL | WIRE COLOR | CIRCUIT DESCRIPTION |
|----------|------------|---------------------|
| A        | R/GN       | System power        |
| B        | GN/Y       | Front fuel injector |

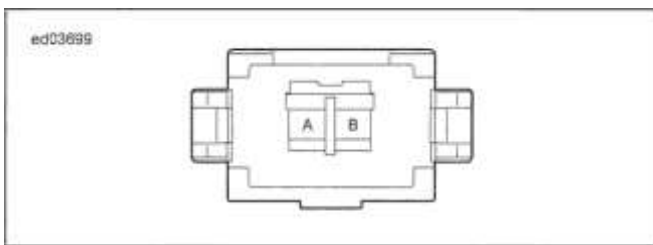


Figure A-95. Front Fuel Injector [84]

Table A-65. Rear Fuel Injector [85]

| TERMINAL | WIRE COLOR | CIRCUIT DESCRIPTION |
|----------|------------|---------------------|
| A        | R/GN       | System power        |
| B        | GY/Y       | Rear fuel injector  |

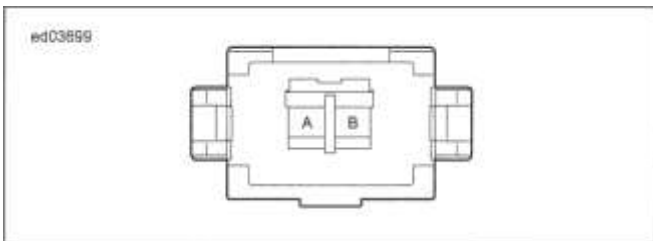


Figure A-96. Rear Fuel Injector [85]

Table A-66. ET Sensor [90]

| TERMINAL | WIRE COLOR | CIRCUIT DESCRIPTION |
|----------|------------|---------------------|
| 1        | GN         | ET sensor           |
| 2        | BK/W       | 5V sensor ground    |



Figure A-97. ET Sensor [90]

Table A-67. DLC [91 B]

| TERMINAL | WIRE COLOR | CIRCUIT DESCRIPTION |
|----------|------------|---------------------|
| 1        | -          | N/C                 |
| 2        | W/R        | CAN high            |

Table A-74. P&A Dash Switch Pack [105R]

| TERMINAL | WIRE COLOR | CIRCUIT DESCRIPTION |
|----------|------------|---------------------|
| 3        | BK         | Ground              |
| 4        | R/Y        | Accessory power     |
| 5        | W/BK       | CAN low             |
| 6        | -          | N/C                 |

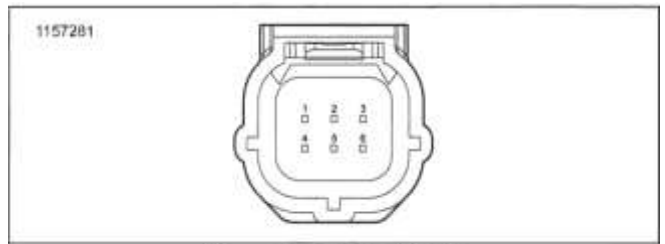


Figure A-98. DLC [91B]

Table A-68. Tail Lamp [93]

| TERMINAL | WIRE COLOR | CIRCUIT DESCRIPTION       |
|----------|------------|---------------------------|
| 1        | BE/W       | Running light power (DOM) |
| 2        | O/W        | Accessory power (HDI)     |
| 3        | R/Y        | Brake lamp power          |
| 4        | BK         | Ground                    |

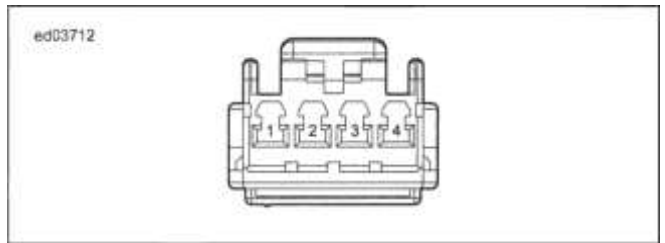


Figure A-99. Tail Lamp [93]

Table A-69. Stop Tail Lamp [94]

| TERMINAL | WIRE COLOR | CIRCUIT DESCRIPTION    |
|----------|------------|------------------------|
| 1        | R/Y        | Accessory power        |
| 2        | BE/BN      | Right rear turn signal |
| 3        | BE         | Running lights power   |
| 4        | BE/R       | Brake lamp power       |
| 5        | BEN        | Left rear turn signal  |
| 6        | BK         | Ground                 |

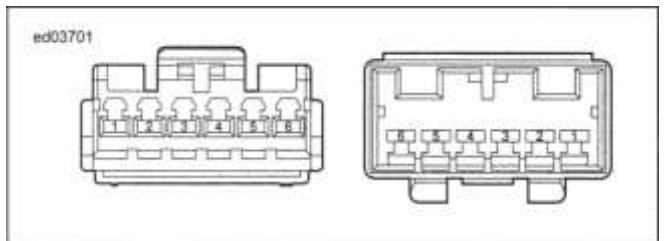


Figure A-100. Stop Tail Lamp [94]

Table A-70. Purge Solenoid [95]

| TERMINAL | WIRE COLOR | CIRCUIT DESCRIPTION |
|----------|------------|---------------------|
| A        | V/GN       | System power        |
| B        | LGN/BK     | Purge solenoid      |



Table A-68. Ignition Coil [83]

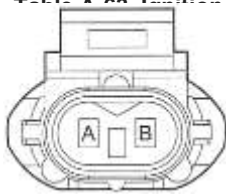


Figure A-101. Purge Solenoid [95]

Table A-71. Right Cooling Fan [97]

| TERMINAL | WIRE COLOR | CIRCUIT DESCRIPTION |
|----------|------------|---------------------|
| A        | BN/BE      | Cooling relay       |
| B        | GY/BK      | Cooling fan right   |

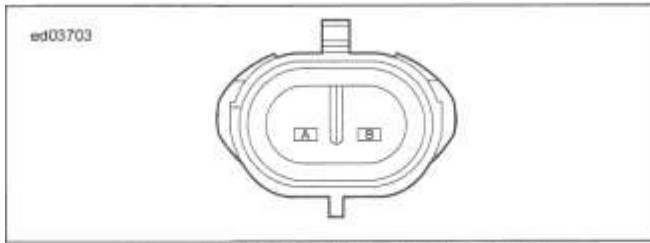


Figure A-102. Right Cooling Fan [97]

Table A-72. CB Antenna [104]

| TERMINAL | WIRE COLOR | CIRCUIT DESCRIPTION |
|----------|------------|---------------------|
| 1        | j BK       | CB antenna cable    |

ed03642



Figure A-103. CB Antenna [104]

Table A-73. OE Dash Switch Pack [105L]

| TERMINAL | WIRE COLOR | CIRCUIT DESCRIPTION |
|----------|------------|---------------------|
| 1        | BN/Y       | Chassis cooling fan |
| 2        | LBEIGN     | OE switch output 2  |
| 3        | BEIGY      | OE switch output 1  |
| 4        | BK         | Ground              |
| 5        | VIBE       | P&A relay power     |
| 6        | -          | NIC                 |

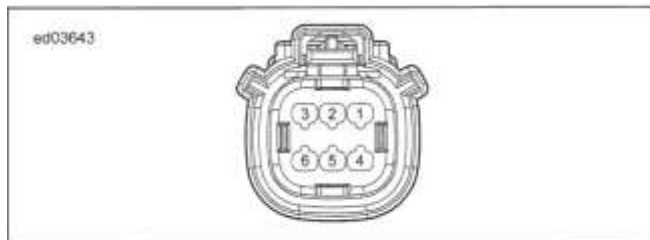


Figure A-104. OE Dash Switch Pack [105L]

Table A-67. DLC [91B]

| TERMINAL | WIRE COLOR | CIRCUIT DESCRIPTION |
|----------|------------|---------------------|
| 1        | -          | NIC                 |
| 2        | LBE/W      | P&A switch output 2 |
| 3        | LBE/Y      | P&A switch output 1 |
| 4        | BK         | Ground              |
| 5        | VIBE       | P&A relay           |
| 6        | -          | NIC                 |

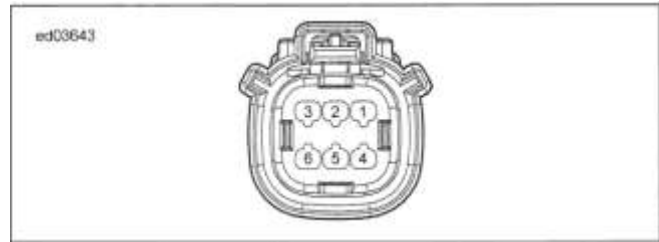


Figure A-105. P&A Dash Switch Pack [105R]

Table A-75. AAT [107]

| TERMINAL | WIRE COLOR | CIRCUIT DESCRIPTION |
|----------|------------|---------------------|
| 1        | W/W        | Air temperature     |
| 2        | BK/W       | 5V sensor ground    |

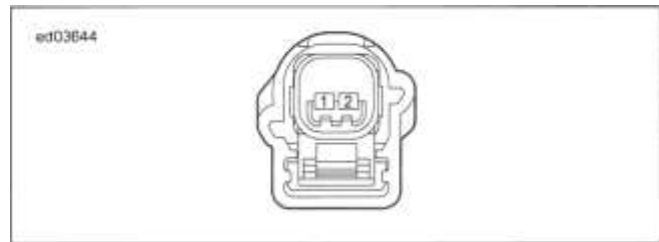


Figure A-106. AAT [107]

Table A-76. Auxiliary Lamp Switch [109]

| TERMINAL | WIRE COLOR | CIRCUIT DESCRIPTION   |
|----------|------------|-----------------------|
| 1        | R/Y        | Accessory power       |
| 2        | -          | NA                    |
| 3        | BK         | Ground                |
| 4        | BEIGY      | AUX lamp switch input |

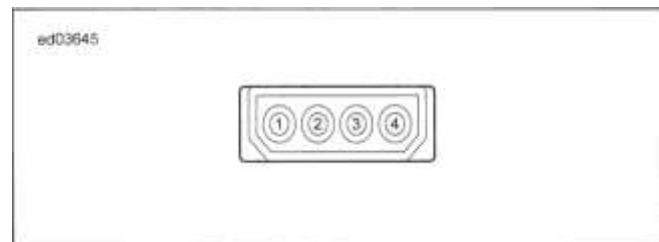


Figure A-107. Auxiliary Lamp Switch [109]

Table A-77. Voltmeter [111]

| TERMINAL | WIRE COLOR | CIRCUIT DESCRIPTION |
|----------|------------|---------------------|
| A        | V/W        | HD-Link output      |
| B        | BK/GN      | Ground              |
| C        | -          | NIC                 |
| D        | RIO        | Battery fuse        |



Figure A-108. Voltmeter [111]

Table A-78. Voltmeter Jumper [111-2] (FLT)

| TERMINAL | WIRE COLOR | CIRCUIT DESCRIPTION |
|----------|------------|---------------------|
| 1        | V/W        | HD-Link output      |
| 2        | BK/GN      | Ground              |
| 3        | -          | N/C                 |
| 4        | R/O        | Battery fuse        |

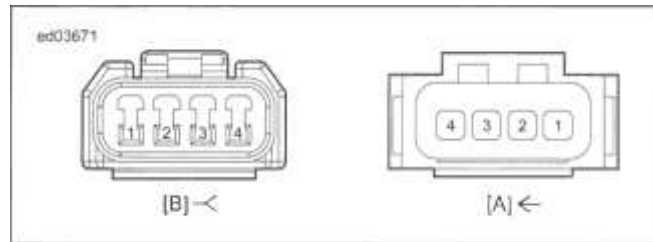


Figure A-109. Voltmeter Jumper [111-2] (FLT)

Table A-79. Fuel Gauge [117] (with Fairing)

| TERMINAL | WIRE COLOR | CIRCUIT DESCRIPTION |
|----------|------------|---------------------|
| A        | V/W        | HD-Link output      |
| B        | BK/GN      | Ground              |
| C        | -          | N/C                 |
| D        | R/O        | Battery fuse        |



Figure A-110. Fuel Gauge [117] (with Fairing)

Table A-80. Fuel Gauge [117] (without Fairing)

| TERMINAL | WIRE COLOR | CIRCUIT DESCRIPTION |
|----------|------------|---------------------|
| 1        | R/Y        | Accessory power     |
| 2        | W/Y        | Fuel level          |
| 3        | -          | N/C                 |
| 4        | BK/GN      | Ground              |

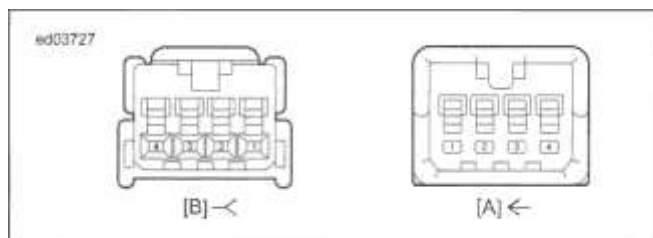


Figure A-111. Fuel Gauge [117] (without Fairing)

Table A-81. Fuel Gauge Jumper [117-2] (FLT)

| TERMINAL | WIRE COLOR | CIRCUIT DESCRIPTION |
|----------|------------|---------------------|
| 1        | V/W        | HD-Link output      |
| 2        | BK/GN      | Ground              |

Table A-81. Fuel Gauge Jumper [117-2] (FLT)

| TERMINAL | WIRE COLOR | CIRCUIT DESCRIPTION |
|----------|------------|---------------------|
| 3        | -          | N/C                 |
| 4        | R/O        | Battery fuse        |

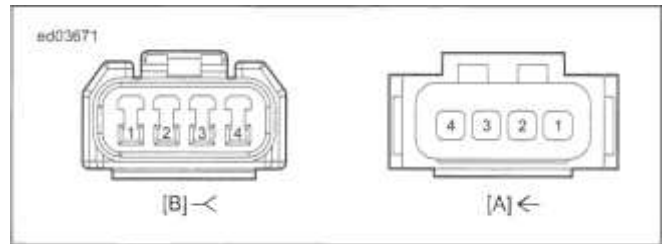


Figure A-112. Fuel Gauge Jumper [117-2] (FLT)

Table A-82. Rear Brake Switch [121]

| TERMINAL | WIRE COLOR | CIRCUIT DESCRIPTION |
|----------|------------|---------------------|
| 1        | BE/GN      | Rear brake switch   |
| 1        | BK         | Ground              |

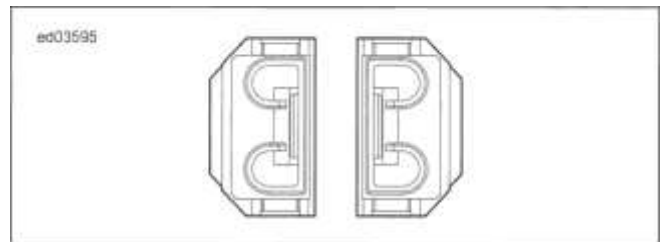


Figure A-113. Rear Brake Switch [121]

Table A-83. Horn [122]

| TERMINAL | WIRE COLOR | CIRCUIT DESCRIPTION |
|----------|------------|---------------------|
| 1        | R/V        | Horn power          |
| 1        | BK         | Ground              |

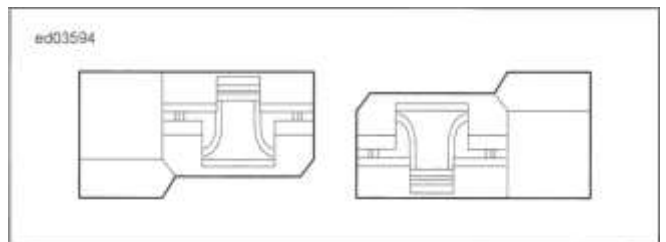


Figure A-114. Horn [122]

Table A-84. Starter Solenoid [128]

| TERMINAL | WIRE COLOR | CIRCUIT DESCRIPTION    |
|----------|------------|------------------------|
| 1        | R/BK       | Starter solenoid power |

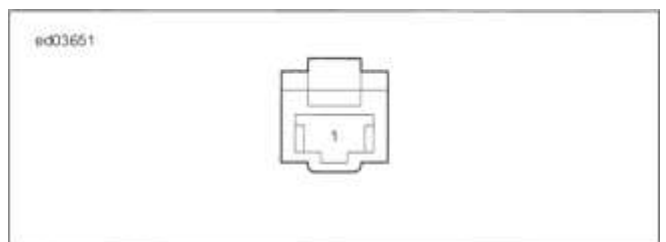


Figure A-115. Starter Solenoid [128]

Table A-85. Neutral Switch [131]

| TERMINAL | WIRE COLOR | CIRCUIT DESCRIPTION  |
|----------|------------|----------------------|
| 1        | W          | Neutral switch input |
| 1        | BK         | Ground               |

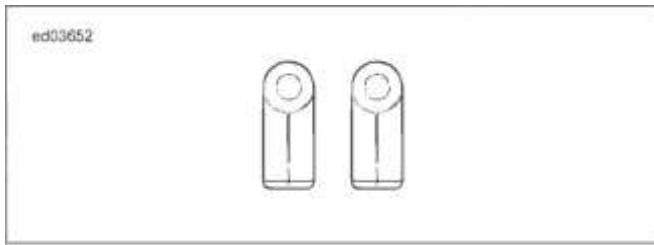


Figure A-116. Neutral Switch [131-1] [131-2]

Table A-86. Power Outlet [132C]

| TERMINAL | WIRE COLOR | CIRCUIT DESCRIPTION |
|----------|------------|---------------------|
| 1        | V/BE       | P&A relay power     |
| 2        | BK         | Ground              |

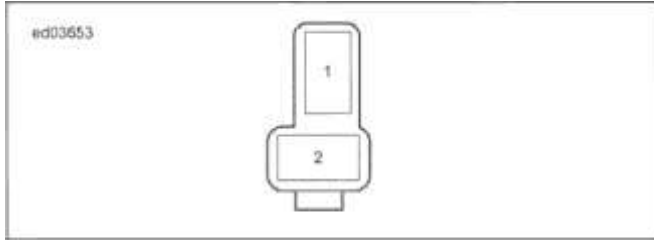


Figure A-117. Power Outlet [132C]

Table A-87. Power Outlet Jumper [132]

| TERMINAL | WIRE COLOR | CIRCUIT DESCRIPTION |
|----------|------------|---------------------|
| 1        | VIBE       | P&A relay power     |
| 2        | BK         | Ground              |

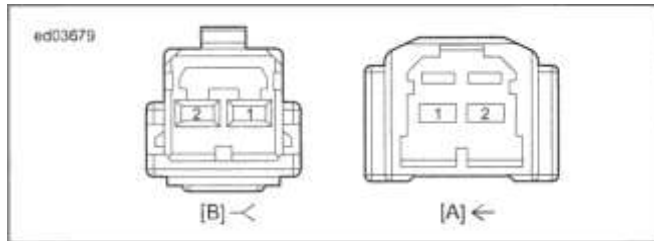


Figure A-118. Power Outlet Jumper [132]

Table A-88. Jiffy Stand [133]

| TERMINAL | WIRE COLOR | CIRCUIT DESCRIPTION |
|----------|------------|---------------------|
| 1        | R/W        | 5V sensor power 1   |
| 2        | LGNIGY     | JSS signal          |
| 3        | BK/GN      | Ground              |

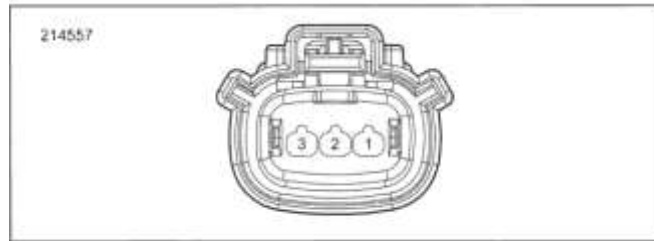


Figure A-119. Jiffy Stand [133]

Table A-89. HO2S Rear [137A]

| TERMINAL | WIRE COLOR | CIRCUIT DESCRIPTION     |
|----------|------------|-------------------------|
| 1        | VIGN       | System power fuse       |
| 2        | BK/PK      | Rear HO2S heater ground |
| 3        | GYIBN      | Rear HO2S               |
| 4        | BK/W       | 5V sensor ground        |

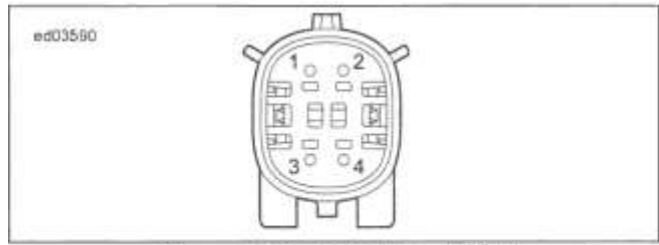


Figure A-120. HO2S Rear [137A]

Table A-90. HO2S Front [137B]

| TERMINAL | WIRE COLOR | CIRCUIT DESCRIPTION |
|----------|------------|---------------------|
| 1        | V          | System power        |
| 2        | W          | HO2S heater ground  |
| 3        | GY         | HO2S                |
| 4        | BK         | 5V sensor ground    |

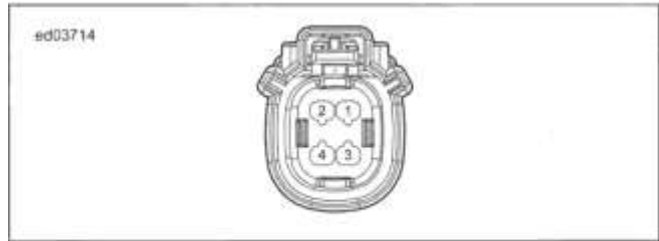


Figure A-121. HO2S Front [137B]

Table A-91. HO2S Front [138A]

| TERMINAL | WIRE COLOR | CIRCUIT DESCRIPTION      |
|----------|------------|--------------------------|
| 1        | VIGN       | System power fuse        |
| 2        | BK/O       | HO2S front heater ground |
| 3        | GNIBN      | HO2S front               |
| 4        | BK/W       | 5V sensor ground         |

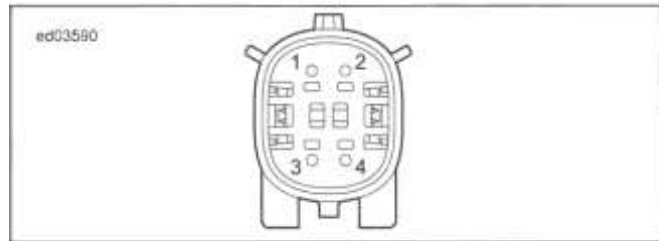


Figure A-122. HO2S Front [138A]

Table A-92. HO2S Rear [138B]

| TERMINAL | WIRE COLOR | CIRCUIT DESCRIPTION |
|----------|------------|---------------------|
| 1        | V          | System power        |
| 2        | W          | HO2S heater ground  |
| 3        | GY         | HO2S                |
| 4        | BK         | 5V sensor ground    |

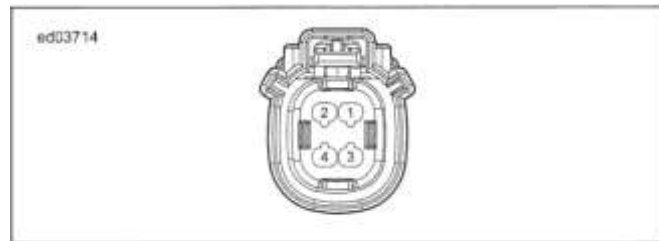


Figure A-123. HO2S Rear [138B]

| TERMINAL | WIRE COLOR | CIRCUIT DESCRIPTION |
|----------|------------|---------------------|
| 1        | BK/W       | 5V Sensor GND 1     |
| 2        | R/W        | 5V Sensor Power 1   |
| 3        | W/O        | Oil Pressure        |

ed04045



[B]-<

Figure A-124. Oil Pressure Sender [1398]

Table A-94. Fuel Pump [141] (With Fairing)

| TERMINAL | WIRE COLOR | CIRCUIT DESCRIPTION |
|----------|------------|---------------------|
| A        | W/Y        | Fuel level          |
| B        | R/BN       | Fuel pump power     |
| C        | BK/GN      | Ground              |
| D        | BK         | Ground              |

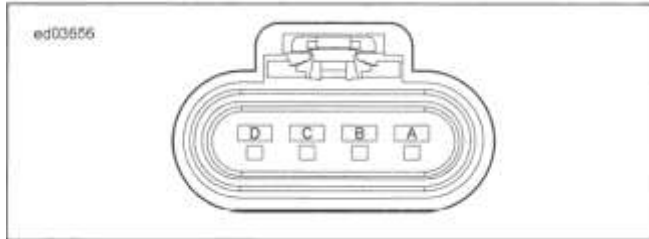


Figure A-125. Fuel Pump [141] (With Fairing)

Table A-95. Fuel Pump [141] (Without Fairing)

| TERMINAL | WIRE COLOR | CIRCUIT DESCRIPTION |
|----------|------------|---------------------|
| A        | W/Y        | Fuel level          |
| B        | R/BN       | Fuel pump power     |
| C        | BK         | Ground              |
| D        | BK         | Ground              |

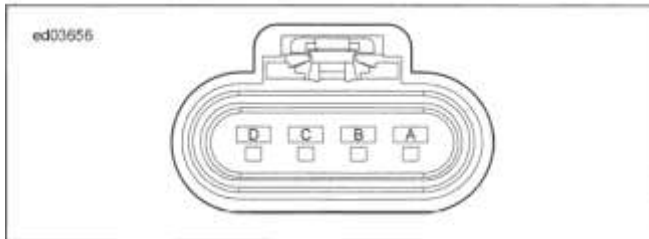


Figure A-126. Fuel Pump [141] (Without Fairing)

Table A-96. Security Siren (Optional) [142]

| TERMINAL | WIRE COLOR | CIRCUIT DESCRIPTION |
|----------|------------|---------------------|
| 1        | R/O        | Battery power       |
| 2        | W/GN       | Security siren      |
| 3        | BK         | Ground              |

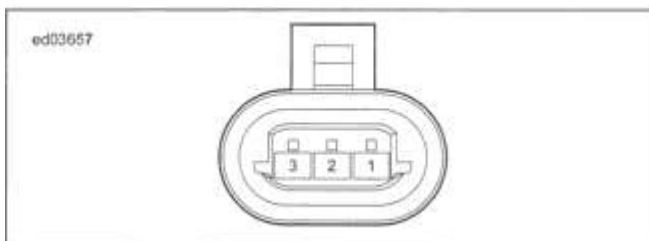


Figure A-127. Security Siren (Optional) [142]

| TERMINAL | WIRE COLOR | CIRCUIT DESCRIPTION  |
|----------|------------|----------------------|
| 1        | O/W        | Running lights power |
| 2        | BK         | Ground               |

ed03650

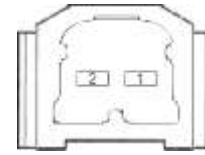


Table A-98. Audio Amplifier 1 [149-1]

| TERMINAL | WIRE COLOR | CIRCUIT DESCRIPTION |
|----------|------------|---------------------|
| 1        | LBE        | Right rear out +    |
| 2        | LBE/BK     | Right rear out -    |
| 3        | LBE/O      | Left rear out +     |
| 4        | LBE/GY     | Left rear out -     |
| 5        | BN/O       | Left front out -    |
| 6        | BN/GY      | Left front out +    |
| 7        | BN/PK      | Right front out +   |
| 8        | BN/GN      | Right front out -   |
| 9        | R          | Battery fuse        |
| 10       | BK         | Ground              |
| 11       | W/R        | CAN high            |
| 12       | -          | N/C                 |
| 13       | -          | N/C                 |
| 14       | -          | N/C                 |
| 15       | -          | N/C                 |
| 16       | R          | Battery fuse        |
| 17       | BK         | Ground              |
| 18       | W/BK       | CAN low             |
| 19       | V/BE       | P&A relay power     |
| 20       | PK/GY      | Left in (-)         |
| 21       | PK/O       | Left in (+)         |
| 22       | PK         | Right in (+)        |
| 23       | PK/BK      | Right in (-)        |

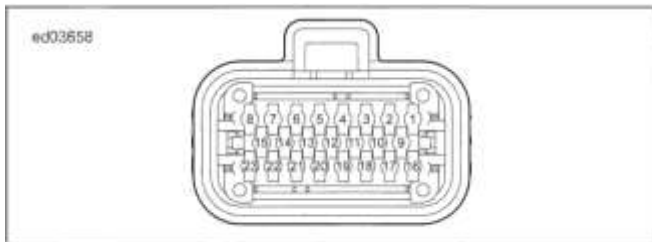


Figure A-129. Audio Amplifier 1 [149-1]

Figure A-128. Front Fender Tip Lamp [143]

**Table A-99. Audio Amplifier 2 [149-2]**

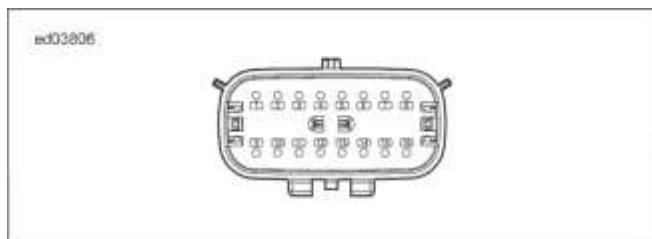
| TERMINAL | WIRE COLOR | CIRCUIT DESCRIPTION |
|----------|------------|---------------------|
| 1        | LBE/O      | Right rear out +    |
| 2        | LBE/GY     | Right rear out -    |
| 3        | LBE        | Right rear out +    |
| 4        | LBE/BK     | Right rear out -    |
| 5        | BN/O       | Left front out -    |
| 6        | BN/GY      | Left front out +    |
| 7        | BN/PK      | Right front out +   |
| 8        | BN/GN      | Right front out -   |
| 9        | R          | Battery fuse        |
| 10       | BK         | Ground              |
| 11       | W/R        | CAN high            |
| 12       | PK/W       | Config 1 (ground)   |
| 13       | -          | N/C                 |
| 14       | -          | N/C                 |
| 15       | -          | N/C                 |
| 16       | R          | Battery fuse        |
| 17       | BK         | Ground              |
| 18       | W/BK       | CAN low             |
| 19       | R/Y        | Accessory power     |
| 20       | PK/GY      | Left in (-)         |
| 21       | PK/O       | Left in (+)         |
| 22       | PK         | Right in (+)        |
| 23       | PK/BK      | Right in (-)        |



**Figure A-130. Audio Amplifier 2 [149-2]**

**Table A-100. Rear Audio [162A] (Except FLHX and FLT)**

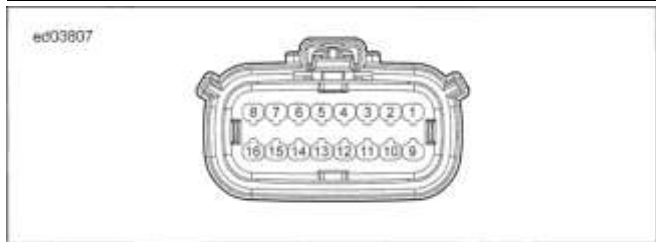
| TERMINAL | WIRE COLOR | CIRCUIT DESCRIPTION    |
|----------|------------|------------------------|
| 1        | LBE/O      | Speaker left rear (+)  |
| 2        | LBE/GY     | Speaker left rear (-)  |
| 3        | LBE/W      | Headset left rear (+)  |
| 4        | BK/PK      | Headset common (-)     |
| 5        | LBE/V      | Headset right rear (+) |
| 6        | R/W        | Microphone rear (+)    |
| 7        | BK         | Microphone common (-)  |
| 8        | BK/W       | Shield                 |
| 9        | LBE        | Speaker right rear (+) |
| 10       | LBE/BK     | Speaker right rear (-) |
| 11       | -          | N/C                    |
| 12       | -          | N/C                    |
| 13       | -          | N/C                    |
| 14       | R/Y        | Accessory power        |
| 15       | LBE/PK     | Rear switch input      |
| 16       | BK/GN      | Ground                 |



**Figure A-131. Rear Audio [162A] (Except FLHX and FLT)**

**Table A-101. Rear Audio [162B] (Except FLHX and FLT)**

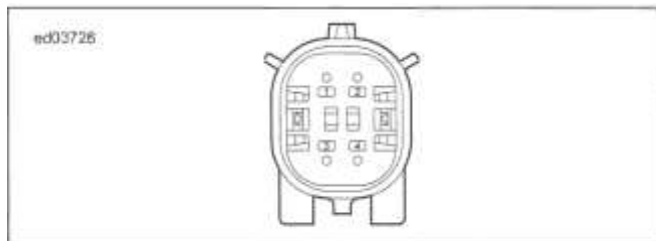
| TERMINAL | WIRE COLOR | CIRCUIT DESCRIPTION    |
|----------|------------|------------------------|
| 1        | LBE/O      | Speaker left rear (+)  |
| 2        | LBE/GY     | Speaker left rear (-)  |
| 3        | PK/GN      | Headset left rear (+)  |
| 4        | BK         | Headset common (-)     |
| 5        | PK/BE      | Headset right rear (+) |
| 6        | R          | Microphone rear (+)    |
| 7        | BK         | Microphone common (-)  |
| 8        | BK/W       | Shield                 |
| 9        | LBE        | Speaker right rear (+) |
| 10       | LBE/BK     | Speaker right rear (-) |
| 11       | -          | N/C                    |
| 12       | -          | N/C                    |
| 13       | -          | N/C                    |
| 14       | W/R        | Accessory power        |
| 15       | W/BN       | Rear switch input      |
| 16       | W          | Ground                 |



**Figure A-132. Rear Audio [162B] (Except FLHX and FLT)**

**Table A-102. Rear Audio [162] (FLHX, FLT)**

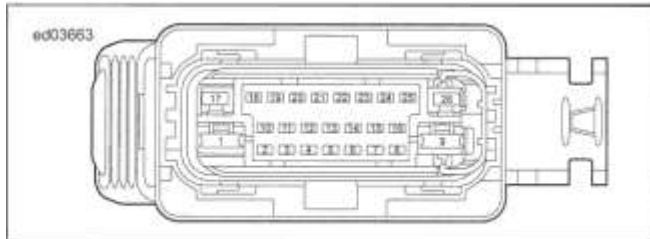
| TERMINAL | WIRE COLOR | CIRCUIT DESCRIPTION    |
|----------|------------|------------------------|
| 1        | LBE/O      | Speaker left rear (+)  |
| 2        | LBE/GY     | Speaker left rear (-)  |
| 3        | LBE        | Speaker right rear (+) |
| 4        | LBE/BK     | Speaker right rear (-) |



**Figure A-133. Rear Audio [162] (FLHX, FLT)**

**Table A-109. Heated Handgrips [189B]**

| TERMINAL | WIRE COLOR | CIRCUIT DESCRIPTION       |
|----------|------------|---------------------------|
| 1        | R          | Battery power (motor)     |
| 2        | -          | N/C                       |
| 3        | -          | N/C                       |
| 4        | -          | N/C                       |
| 5        | -          | N/C                       |
| 6        | -          | N/C                       |
| 7        | -          | N/C                       |
| 8        | -          | N/C                       |
| 9        | BK         | Ground                    |
| 10       | W/BK       | CAN low                   |
| 11       | -          | N/C                       |
| 12       | -          | N/C                       |
| 13       | -          | N/C                       |
| 14       | O/BN       | Rear WSS -                |
| 15       | O/BE       | Front WSS +               |
| 16       | -          | N/C                       |
| 17       | R          | Battery power (solenoids) |
| 18       | W/R        | CAN high                  |
| 19       | -          | N/C                       |
| 20       | -          | N/C                       |
| 21       | -          | N/C                       |
| 22       | -          | N/C                       |
| 23       | O/PK       | Rear WSS +                |
| 24       | O/BK       | Front WSS -               |
| 25       | -          | N/C                       |
| 26       | BK/GN      | Ground (ECU)              |

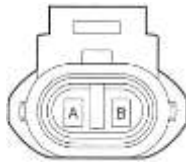


**Figure A-134. ABS [166]**

**Table A-104. Front WSS [167] (with Fairing)**

| TERMINAL | WIRE COLOR | CIRCUIT DESCRIPTION |
|----------|------------|---------------------|
| A        | O/BE       | Front WSS high      |
| B        | O/BK       | Front WSS low       |

ed03664

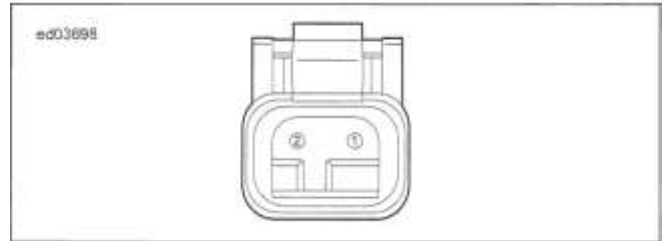


**Figure A-135. Front WSS [167] (with Fairing)**

**Table A-105. Front WSS [167] (without Fairing)**

| TERMINAL | WIRE COLOR | CIRCUIT DESCRIPTION |
|----------|------------|---------------------|
| 1        | O/BE       | Front WSS high      |
| 2        | O/BK       | Front WSS low       |

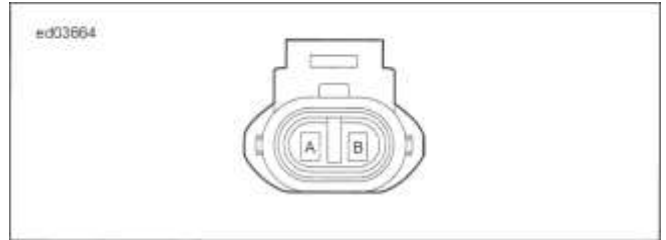
**Table A-113. TGS [204B]**



**Figure A-136. Front WSS [167] (without Fairing)**

**Table A-106. Rear WSS [168]**

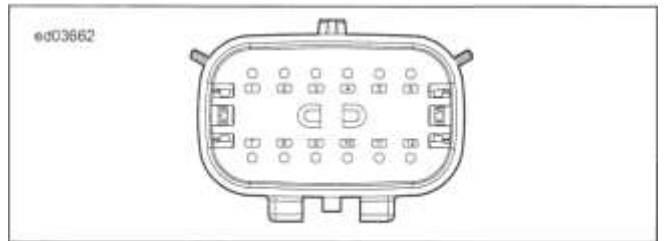
| TERMINAL | WIRE COLOR | CIRCUIT DESCRIPTION |
|----------|------------|---------------------|
| A        | O/PK       | Rear WSS high       |
| B        | O/BN       | RearWSS low         |



**Figure A-137. Rear WSS [168]**

**Table A-107. CB Module [184]**

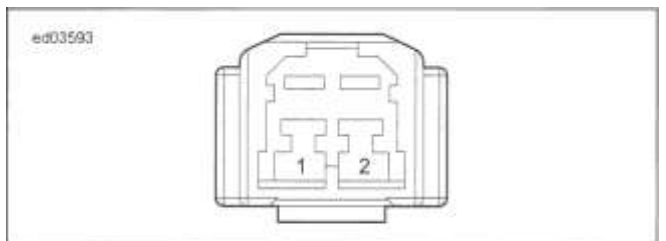
| TERMINAL | WIRE COLOR | CIRCUIT DESCRIPTION        |
|----------|------------|----------------------------|
| 1        | R          | Microphone sum out(+)      |
| 2        | BK         | Microphone sum out (-)     |
| 3        | R          | Audio in 1 right (+)       |
| 4        | W          | Audio in 1 left/mono(+)    |
| 5        | BK         | Audio in 1 shield/mono(-)  |
| 6        | R          | Audio in 3 shield/mono (-) |
| 7        | W          | Audio in 3 left/mono (+)   |
| 8        | BK/Y       | Audio in 3 shield/mono (-) |
| 9        | R/BE       | P&A relay power            |
| 10       | BK         | Ground                     |
| 11       | W/PK       | Aux CAN high               |
| 12       | W/BN       | Aux CAN low                |



**Figure A-138. CB Module [184]**

**Table A-108. Heated Handgrips [189A]**

| TERMINAL | WIRE COLOR | CIRCUIT DESCRIPTION |
|----------|------------|---------------------|
| 1        | R          | P&A power           |
| 2        | BK         | Ground              |



**Figure A-139. Heated Handgrips [189A]**

Table A-103. ABS [1661]

| TERMINAL | WIRE COLOR | CIRCUIT DESCRIPTION |
|----------|------------|---------------------|
| 1        | V/BE       | P&A power           |
| 2        | BK         | Ground              |

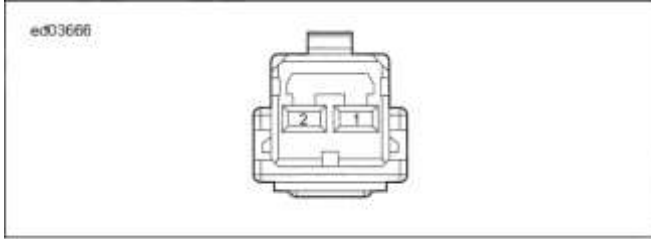


Figure A-140. Heated Handgrips [189B]

Table A-110. GPS Antenna [193]

| TERMINAL | WIRE COLOR | CIRCUIT DESCRIPTION |
|----------|------------|---------------------|
| 1        | Black      | GPS antenna cable   |

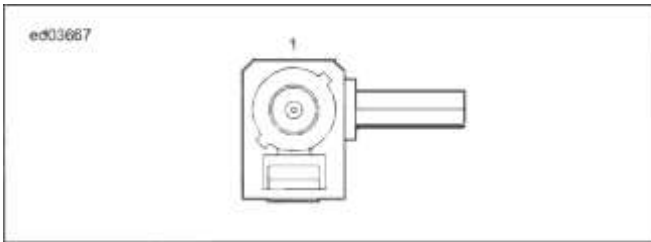


Figure A-141. GPS Antenna [193]

Table A-111. ACR [203]

| TERMINAL | WIRE COLOR | CIRCUIT DESCRIPTION |
|----------|------------|---------------------|
| 1        | VIGN       | System power fuse   |
| 2        | LGWR       | ACR enable          |

ed03669

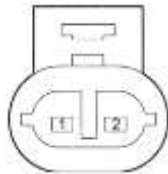


Figure A-142. ACR [203]

Table A-112. TGS [204A]

| TERMINAL | WIRE COLOR | CIRCUIT DESCRIPTION |
|----------|------------|---------------------|
| 1        | R/W        | 5V sensor power 1   |
| 2        | GNW        | TGS 1               |
| 3        | BK/W       | 5V sensor ground 1  |
| 4        | RIGY       | 5V sensor power 2   |
| 5        | GY/W       | TGS2                |
| 6        | BK/GY      | 5V sensor ground 2  |

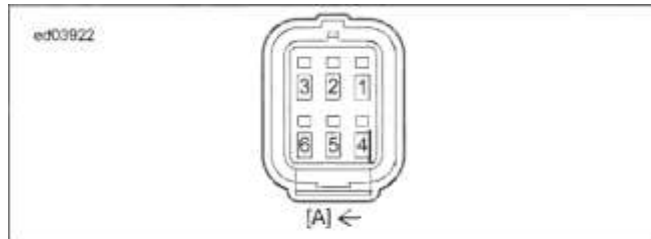


Figure A-143. TGS [204A]

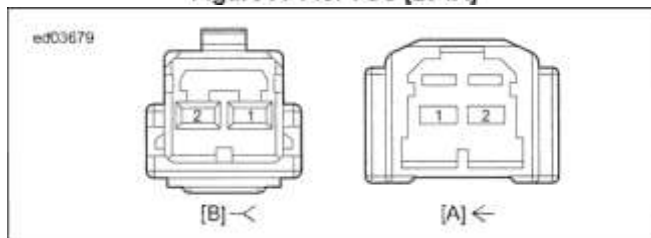


Figure A-146. Heated Handgrip Interconnect [206]

| TERMINAL | WIRE COLOR | CIRCUIT DESCRIPTION |
|----------|------------|---------------------|
| 1        | R          | 5V sensor power 1   |
| 2        | W          | TGS 1               |
| 3        | BK         | 5V sensor ground 1  |
| 4        | R          | 5V sensor power 2   |
| 5        | W          | TGS2                |
| 6        | BK         | 5V sensor ground 2  |

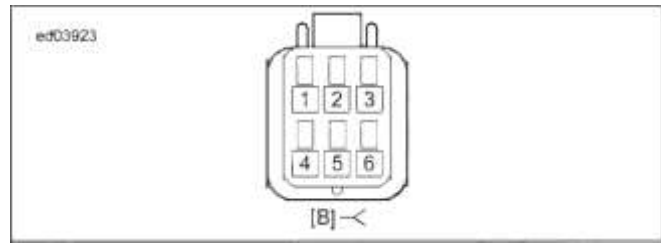


Figure A-144. TGS [2048]

Table A-114. Chassis Cooling Fan Switch [205]

| TERMINAL | WIRE COLOR | CIRCUIT DESCRIPTION        |
|----------|------------|----------------------------|
| 1        | VIBE       | P&A relay power            |
| 2        | -          | NIC                        |
| 3        | -          | NIC                        |
| 4        | BN/Y       | Chassis cooling fan switch |

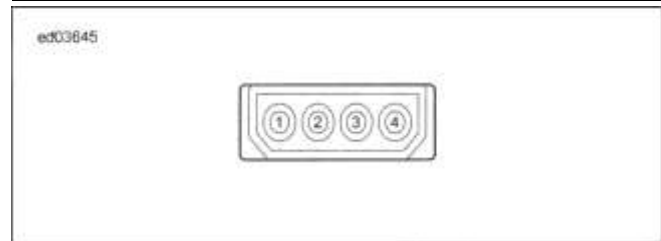


Figure A-145. Chassis Cooling Fan Switch [205]

Table A-115. Heated Handgrip Interconnect [206]

| TERMINAL | WIRE COLOR | CIRCUIT DESCRIPTION |
|----------|------------|---------------------|
| 1        | W          | P&A power           |
| 2        | BK         | Ground              |

Table A-116. Security Antenna [209]

| TERMINAL | WIRE COLOR | CIRCUIT DESCRIPTION   |
|----------|------------|-----------------------|
| 1        | R          | Security antenna high |
| 2        | BK         | Security antenna low  |

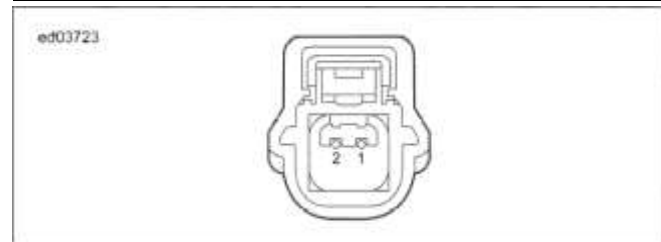


Figure A-147. Security Antenna [209]

Table A-117. TCA [211]

| TERMINAL | WIRE COLOR | CIRCUIT DESCRIPTION |
|----------|------------|---------------------|
| A        | GY/O       | ETC low             |
| B        | BK/W       | 5V sensor ground 1  |
| C        | GN/N       | TPS 1               |
| D        | R/W        | 5V sensor power 1   |
| E        | GYN        | TPS 2               |
| F        | GN/O       | ETC high            |

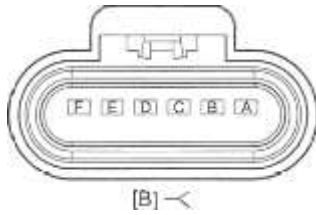


Figure A-148. TCA [211]

Table A-118. Left Cooling Fan [215]

| TERMINAL | WIRE COLOR | CIRCUIT DESCRIPTION     |
|----------|------------|-------------------------|
| A        | BN/BE      | Cooling fan relay power |
| B        | GN/BK      | Cooling fan left        |

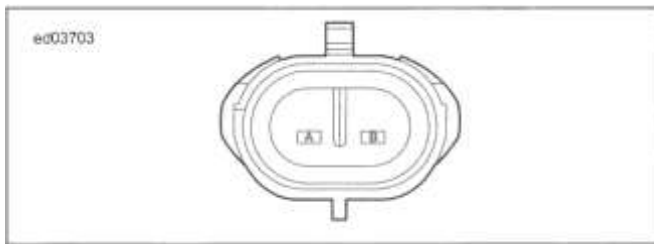


Figure A-149. Left Cooling Fan [215]

Table A-119. Driver Headset [225]

| TERMINAL | WIRE COLOR | CIRCUIT DESCRIPTION   |
|----------|------------|-----------------------|
| 1        | BK         | Microphone common (-) |
| 2        | BK         | Headset common (-)    |
| 3        | PK/BE      | Rear RT headset (+)   |
| 4        | R          | Rear microphone (+)   |
| 5        | PK/GN      | Rear LT headset (+)   |
| 6        | BK         | Jumper                |
| 7        | -          | N/C                   |
| TAB      | BK/W       | Microphone shield     |

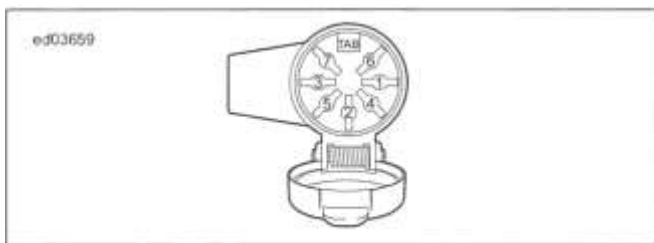


Figure A-150. Driver Headset [225]

Table A-120. Rear Lighting Jumper Harness [226]

| TERMINAL | WIRE COLOR | CIRCUIT DESCRIPTION    |
|----------|------------|------------------------|
| 1        | BK         | Ground                 |
| 2        | -          | N/C                    |
| 3        | BE/BN      | Right rear turn signal |
| 4        | BEN        | Left rear turn signal  |
| 5        | BE/R       | Brake light power      |
| 6        | BE         | Running lights power   |
| 7        | BK         | Ground                 |
| 8        | -          | N/C                    |
| 9        | -          | N/C                    |
| 10       | -          | N/C                    |
| 11       | -          | N/C                    |
| 12       | R/Y        | Accessory power        |

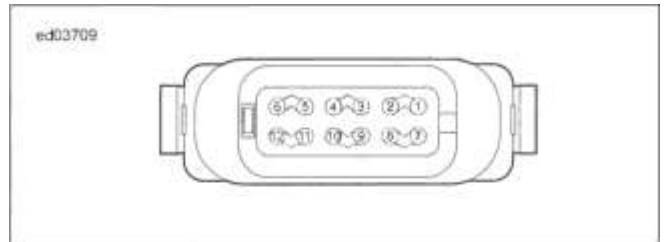


Figure A-151. Rear Lighting Jumper Harness [226]

Table A-121. Left Cooling Fan Jumper [232L]

| TERMINAL | WIRE COLOR | CIRCUIT DESCRIPTION     |
|----------|------------|-------------------------|
| 1        | GN/BK      | Cooling fan left        |
| 2        | BN/BE      | Cooling fan relay power |
| 3        | GY/GN      | Coolant temperature     |
| 4        | BK/W       | 5V sensor ground        |

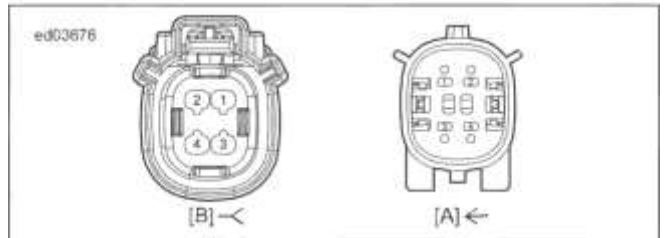


Figure A-152. Left Cooling Fan jumper [232L]

Table A-122. Right Cooling Fan Jumper [232R]

| TERMINAL | WIRE COLOR | CIRCUIT DESCRIPTION |
|----------|------------|---------------------|
| 1        | GY/BK      | Cooling fan right   |
| 2        | BN/BE      | Cooling relay power |

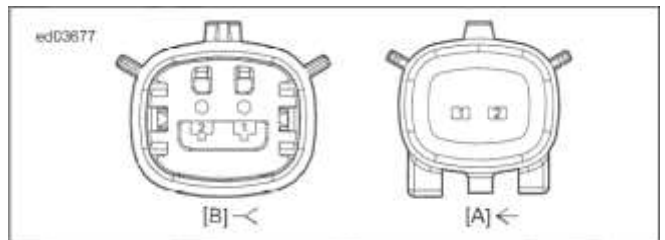


Figure A-153. Right Cooling Fan Jumper [232R]

Table A-123. Cooling Pump [235]

| TERMINAL | WIRE COLOR | CIRCUIT DESCRIPTION  |
|----------|------------|----------------------|
| 1        | BN/BE      | Cooling relay power  |
| 2        | BN/BK      | Cooling pump control |
| 3        | BK         | Ground               |



Table A-126. P&A CAN [243]

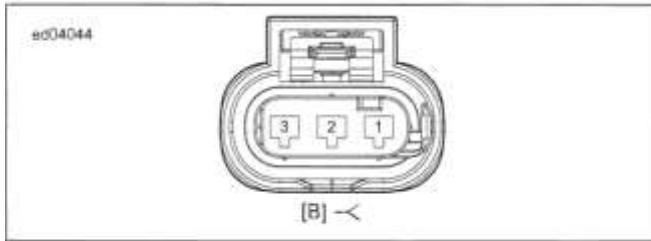


Figure A-154. Cooling Pump [235]

Table A-124. ECT Sensor [236]

| TERMINAL | WIRE COLOR | CIRCUIT DESCRIPTION |
|----------|------------|---------------------|
| A        | GY/GN      | Coolant temperature |
| B        | BK/W       | 5V sensor ground    |

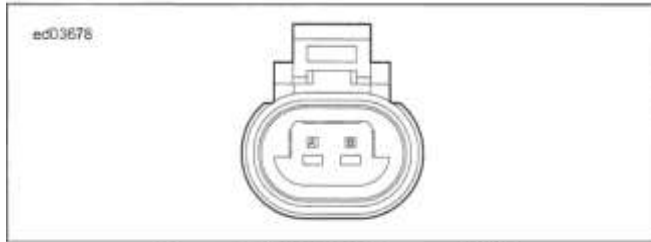


Figure A-155. ECT Sensor [236]

| TERMINAL | WIRE COLOR | CIRCUIT DESCRIPTION             |
|----------|------------|---------------------------------|
| A1       | -          | N/C                             |
| A2       | R          | Security antenna high           |
| A3       | W/BN       | Start enable                    |
| A4       | BK         | Security RF antenna             |
| B1       | -          | N/C                             |
| B2       | BK         | Security antenna low            |
| B3       | BE/GY      | Aux lamp switch                 |
| B4       | -          | N/C                             |
| C1       | -          | N/C                             |
| C2       | -          | N/C                             |
| C3       | W/BE       | Ignition/accessory switch input |
| C4       | W/GY       | Engine stop switch input        |
| D1       | -          | N/C                             |
| D2       | W/R        | CAN high                        |
| D3       | W          | Neutral switch input            |
| D4       | -          | N/C                             |
| E1       | -          | N/C                             |
| E2       | W/BK       | CAN low                         |
| E3       | W/O        | Oil pressure switch input       |
| E4       | RN         | Horn power                      |
| F1       | -          | N/C                             |
| F2       | -          | N/C                             |
| F3       | BE/GN      | Brake switch input              |
| F4       | R/BN       | Fuel pump power                 |
| G1       | -          | N/C                             |
| G2       | -          | N/C                             |
| G3       | -          | N/C                             |
| G4       | BK/GN      | Ground                          |
| H1       | -          | N/C                             |
| H2       | W/GN       | Security siren                  |
| H3       | -          | N/C                             |
| H4       | -          | N/C                             |
| J1       | -          | N/C                             |
| J2       | BE/O       | Right front turn signal         |
| J3       | BE         | Running/position lights         |
| J4       | BE/PK      | Left front turn signal          |
| K1       | -          | N/C                             |
| K2       | BE/BN      | Right rear turn signal          |
| K3       | BE/R       | Brake lamp power                |
| K4       | BEN        | Left rear turn signal           |
| L1       | -          | N/C                             |
| L2       | R/BK       | Starter solenoid power          |
| L3       | R/GN       | System power                    |
| L4       | BE/BK      | Front running/fog light power   |
| M1       | -          | N/C                             |
| M2       | R/Y        | Accessory power                 |
| M3       | BE/W       | High beam power                 |
| M4       | BE/Y       | Low beam power                  |

ed03681

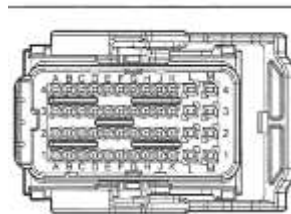


Figure A-156. BCM [242]

| TERMINAL | WIRE COLOR | CIRCUIT DESCRIPTION |
|----------|------------|---------------------|
| 1        | W/R        | CAN high            |
| 2        | W/BK       | CAN low             |
| 3        | W/R        | CAN high            |
| 4        | W/BK       | CAN low             |

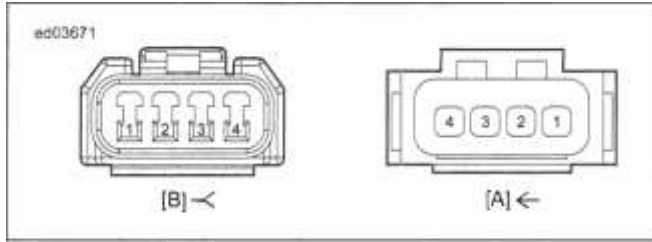


Figure A-157. P&A CAN [243]

Table A-127. Power Outlet [258]

| TERMINAL | WIRE COLOR | CIRCUIT DESCRIPTION |
|----------|------------|---------------------|
| A        | V/BE       | P&A relay power     |
| B        | BK         | Ground              |

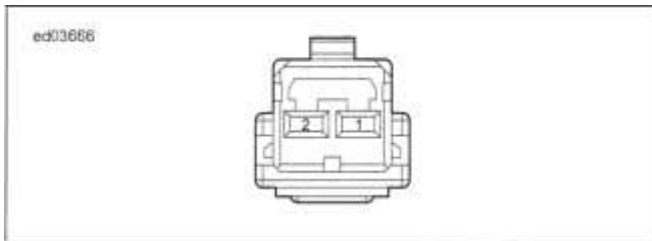


Figure A-158. Power Outlet [258]

Table A-128. BCM Power [259]

| TERMINAL | WIRE COLOR | CIRCUIT DESCRIPTION |
|----------|------------|---------------------|
| 1        | R          | Battery power       |



Figure A-159. BCM Power [259]

Table A-129. Rear Lighting Jumper Harness [262] (DOM)

| TERMINAL | WIRE COLOR | CIRCUIT DESCRIPTION    |
|----------|------------|------------------------|
| 1        | V/BN       | Right rear turn signal |
| 2        | V          | Left rear turn signal  |
| 3        | -          | N/C                    |
| 4        | -          | N/C                    |
| 5        | BK         | Ground                 |
| 6        | BK         | Ground                 |
| 7        | BK         | LP lamp                |
| 8        | BE         | Left tail lamp         |
| 9        | BE         | Right tail lamp        |
| 10       | -          | N/C                    |
| 11       | BK         | LP ground              |
| 12       | -          | N/C                    |

Table A-125. BCM [242]

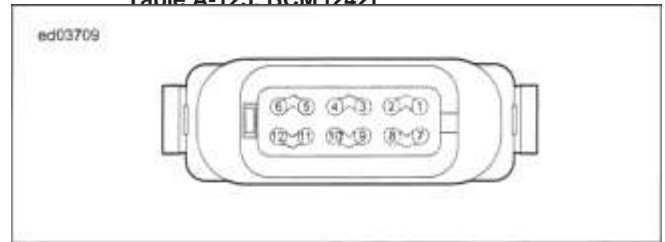


Figure A-160. Rear Lighting Jumper Harness [262] (DOM)

Table A-130. Rear Lighting Jumper Harness [262] (Canada)

| TERMINAL | WIRE COLOR | CIRCUIT DESCRIPTION    |
|----------|------------|------------------------|
| 1        | BE/BN      | Right rear turn signal |
| 2        | BE         | Running lights power   |
| 3        | BE/R       | Brake light power      |
| 4        | BK         | Ground                 |
| 5        | BK         | Ground                 |
| 6        | -          | N/C                    |
| 7        | BEN        | Left rear turn signal  |
| 8        | -          | N/C                    |
| 9        | -          | N/C                    |
| 10       | R/Y        | Accessory power        |
| 11       | -          | N/C                    |
| 12       | -          | N/C                    |

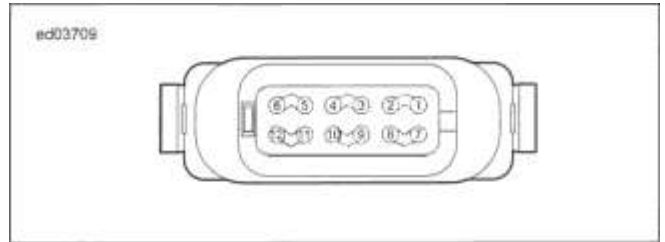


Figure A-161. Rear Lighting Jumper Harness [262] (Canada)

Table A-131. Rear Lighting Jumper Harness [262] (HDI)

| TERMINAL | WIRE COLOR | CIRCUIT DESCRIPTION    |
|----------|------------|------------------------|
| 1        | GN/W       | Right rear turn signal |
| 2        | W/BK       | Right tail lamp        |
| 3        | R/W        | Right stop lamp        |
| 4        | Y/W        | Ground                 |
| 5        | BK         | Ground                 |
| 6        | -          | N/C                    |
| 7        | GN         | Left rear turn signal  |
| 8        | W          | Left tail lamp         |
| 9        | R          | Left stop lamp         |
| 10       | BK         | LP lamp                |
| 11       | Y          | Ground                 |
| 12       | -          | N/C                    |

ed03709



Figure A-162. Rear Lighting Jumper Harness [262] (HDI)

Table A-132. P&A Audio [280]

| TERMINAL | WIRE COLOR | CIRCUIT DESCRIPTION   |
|----------|------------|-----------------------|
| 1        | R          | Microphone front (+)  |
| 2        | R/W        | Microphone rear (-)   |
| 3        | BK         | Microphone common (-) |

Table A-132. P&A Audio [280]

| TERMINAL | WIRE COLOR | CIRCUIT DESCRIPTION     |
|----------|------------|-------------------------|
| 4        | PK/BE      | Headset right front (+) |
| 5        | PK/GN      | Headset left front (+)  |
| 6        | BK/PK      | Headset common (-)      |
| 7        | LBEN       | Headset right rear (+)  |
| 8        | LBE/W      | Headset left rear (+)   |
| 9        | VIBE       | P&A relay power         |
| 10       | BK         | Ground                  |
| 11       | W/PK       | Aux CAN high            |
| 12       | W/BN       | Aux CAN low             |

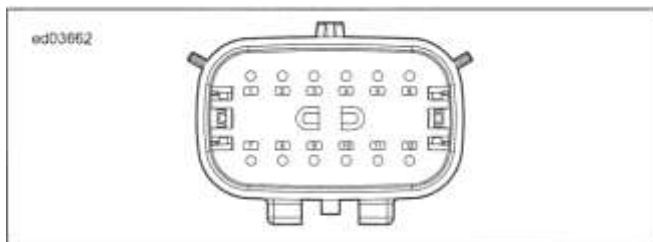


Figure A-163. P&A Audio [280]

Table A-133. Battery Tender [281]

| TERMINAL | WIRE COLOR | CIRCUIT DESCRIPTION |
|----------|------------|---------------------|
| 1        | R          | Battery power       |
| 2        | BK         | Ground              |

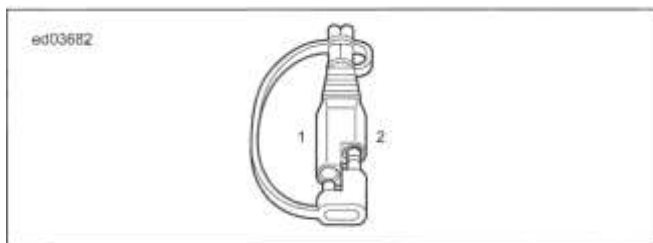


Figure A-164. Battery Tender [281]

Table A-134. Ground [283]

| TERMINAL | WIRE COLOR | CIRCUIT DESCRIPTION |
|----------|------------|---------------------|
| 1        | BK         | AM/FM antenna base  |

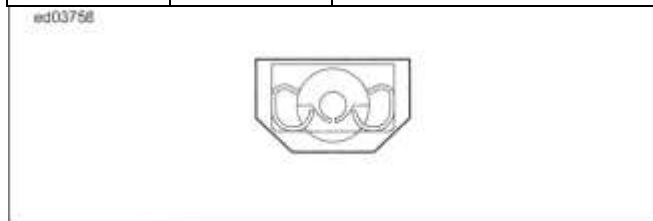


Figure A-165. Ground [283]

Table A-135. Tour-Pak Lights [287]

| TERMINAL | WIRE COLOR | CIRCUIT DESCRIPTION    |
|----------|------------|------------------------|
| A        | BE/BN      | Right rear turn signal |
| B        | BK         | Ground                 |
| C        | BE         | Running lights power   |
| D        | BEN        | Left rear turn signal  |
| E        | BE/R       | Brake light power      |



Figure A-166. Tour-Pak Lights [287]

Table A-136. Left Saddlebag [288]

| TERMINAL | WIRE COLOR | CIRCUIT DESCRIPTION |
|----------|------------|---------------------|
| 1        | W/R        | CAN high            |
| 2        | W/BK       | CAN low             |
| 3        | R          | Battery fuse        |
| 4        | R          | Battery fuse        |
| 5        | R/Y        | Accessory power     |
| 6        | BN/PK      | Right front out +   |
| 7        | BN/O       | Left front out -    |
| 8        | PK/GY      | Left in (-)         |
| 9        | PK/BK      | Right in (-)        |
| 10       | BN/GN      | Right front out -   |
| 11       | BN/GY      | Left front out +    |
| 12       | PK/O       | Right in (-)        |
| 13       | PK         | Right in (+)        |
| 14       | BK         | Ground              |
| 15       | BK         | Ground              |
| 16       | LBE        | Right rear out +    |
| 17       | LBE/BK     | Right rear out -    |
| 18       | -          | N/C                 |

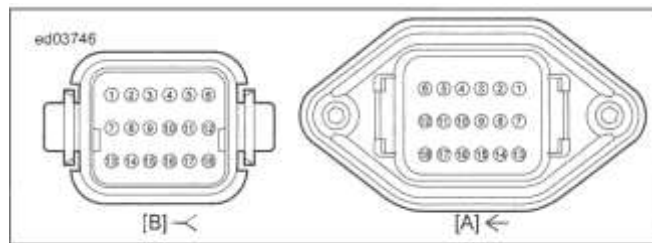


Figure A-167. Left Saddlebag [288]

Table A-137. Speaker POD Interconnect [296A]

| TERMINAL | WIRE COLOR | CIRCUIT DESCRIPTION |
|----------|------------|---------------------|
| 1        | LBE/O      | Speaker left (+)    |
| 2        | LBE/GY     | Speaker left (-)    |
| 3        | LBE        | Speaker right (+)   |
| 4        | LBE/BK     | Speaker right (-)   |

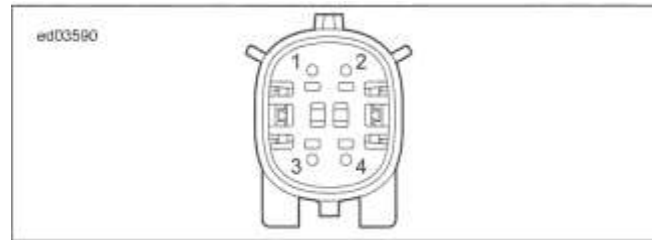


Figure A-168. Speaker POD Interconnect [296A]

Table A-138. Speaker POD Interconnect [296B]

| TERMINAL | WIRE COLOR | CIRCUIT DESCRIPTION |
|----------|------------|---------------------|
| 1        | PK/O       | Speaker left (+)    |
| 2        | PK/GY      | Speaker left (-)    |
| 3        | PK         | Speaker right (+)   |
| 4        | PK/BK      | Speaker right (-)   |



Figure A-169. Speaker POD Interconnect [296B]

ed03650

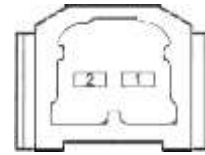


Figure A-173. P&A Accessory Power [299]

Table A-139. Speaker POD Interconnect [297A]

| TERMINAL | WIRE COLOR | CIRCUIT DESCRIPTION |
|----------|------------|---------------------|
| 1        | LBE/O      | Speaker left (+)    |
| 2        | LBE/GY     | Speaker left (-)    |
| 3        | LBE        | Speaker right (+)   |
| 4        | LBE/BK     | Speaker right (-)   |

Table A-143. Front Knock Sensor [315]

| TERMINAL | WIRE COLOR | CIRCUIT DESCRIPTION   |
|----------|------------|-----------------------|
| 1        | LGN/W      | Front knock sensor LO |
| 2        | BN/W       | Front knock sensor HI |

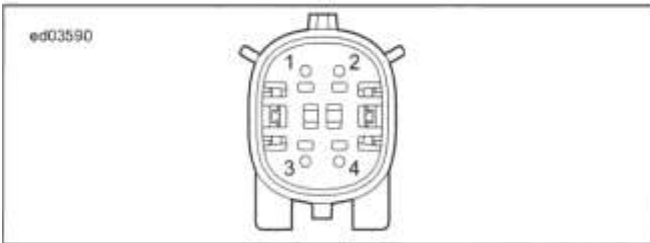


Figure A-170. Speaker POD Interconnect [297A]

Table A-140. Speaker POD Interconnect [297B]

| TERMINAL | WIRE COLOR | CIRCUIT DESCRIPTION |
|----------|------------|---------------------|
| 1        | BN/O       | Speaker left (+)    |
| 2        | BN/GY      | Speaker left (-)    |
| 3        | BN/PK      | Speaker right (+)   |
| 4        | BN/GN      | Speaker right (-)   |

Table A-144. Rear Knock Sensor [316]

| TERMINAL | WIRE COLOR | CIRCUIT DESCRIPTION  |
|----------|------------|----------------------|
| 1        | LGNN       | Rear knock sensor LO |
| 2        | BNN        | Rear knock sensor HI |

ed04043



Figure A-174. Knock Sensor

Table A-145. Oil Cooling Fan [317]

| TERMINAL | WIRE COLOR | CIRCUIT DESCRIPTION     |
|----------|------------|-------------------------|
| A        | BN/BE      | Cooling relay power     |
| B        | GY/BK      | Oil cooling fan control |

ed03703

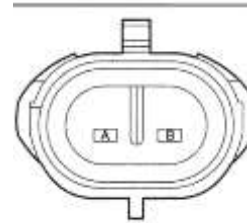


Figure A-175. Oil Cooling Fan [317]

Table A-146. Chassis Cooling Fan [318]

| TERMINAL | WIRE COLOR | CIRCUIT DESCRIPTION         |
|----------|------------|-----------------------------|
| A        | V/BK       | Chassis cooling fan control |
| B        | BN/BE      | Cooling relay power         |

ed03664

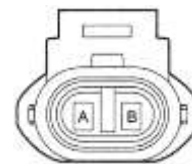


Figure A-176. Chassis Cooling Fan [318]



Figure A-171. Speaker POD Interconnect [297B]

Table A-141. Right Saddlebag Speaker [298]

| TERMINAL | WIRE COLOR | CIRCUIT DESCRIPTION         |
|----------|------------|-----------------------------|
| 1        | LBE        | Right saddlebag speaker(+)  |
| 2        | LBE/BK     | Right saddlebag speaker (-) |

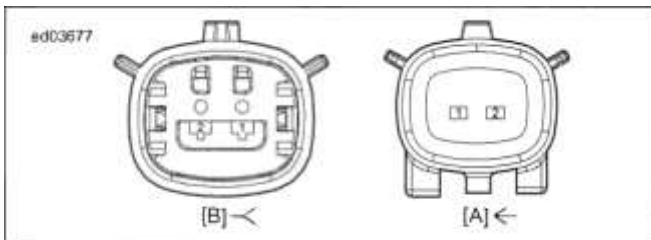


Figure A-172. Right Saddlebag Speaker [298]

Table A-142. P&A Accessory Power [299]

| TERMINAL | WIRE COLOR | CIRCUIT DESCRIPTION |
|----------|------------|---------------------|
| 1        | V/BE       | System power fuse   |
| 2        | BK         | Ground              |

Table A-147. Termination Resistor [319]

| TERMINAL | WIRE COLOR | CIRCUIT DESCRIPTION |
|----------|------------|---------------------|
| A        | W/R        | CAN High            |
| B        | W/BK       | CAN Low             |



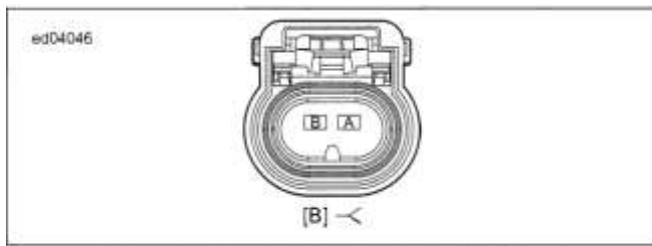


Figure A-177. Termination Resistor [319]

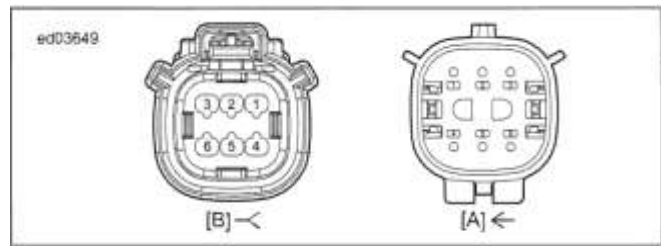


Figure A-180. TCU [339]

Table A-148. P&A Accessory [325]

| TERMINAL | WIRE COLOR | CIRCUIT DESCRIPTION |
|----------|------------|---------------------|
| 1        | V/BE       | P&A relay power     |
| 2        | BK         | Ground              |
| 3        | -          | N/C                 |

Table A-151. HO2S Sensor 2 [340A]

| TERMINAL | WIRE COLOR | CIRCUIT DESCRIPTION         |
|----------|------------|-----------------------------|
| 1        | V/GN       | System power fuse           |
| 2        | BK/O       | HO2S sensor 2 heater ground |
| 3        | GN/BN      | HO2S sensor 2               |
| 4        | BK/W       | 5V sensor ground            |



Figure A-178. P&A Accessory [325]

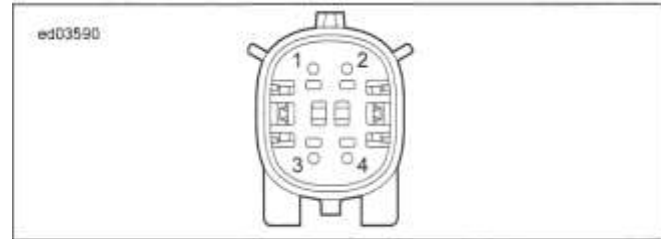


Figure A-181. HO2S Sensor 2 [340A]

Table A-149. IMU [333]

| TERMINAL | WIRE COLOR | CIRCUIT DESCRIPTION |
|----------|------------|---------------------|
| 1        | BK/GN      | Ground              |
| 2        | W/BK       | CAN low             |
| 3        | W/R        | CAN high            |
| 4        | R/GN       | System power        |

Table A-152. HO2S Sensor 2 [340B]

| TERMINAL | WIRE COLOR | CIRCUIT DESCRIPTION         |
|----------|------------|-----------------------------|
| 1        | V          | System power                |
| 2        | W          | HO2S sensor 2 heater ground |
| 3        | GY         | HO2S sensor 2               |
| 4        | BK         | 5V sensor ground            |

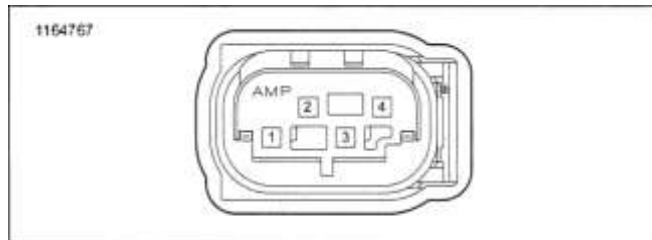


Figure A-179. IMU [333]

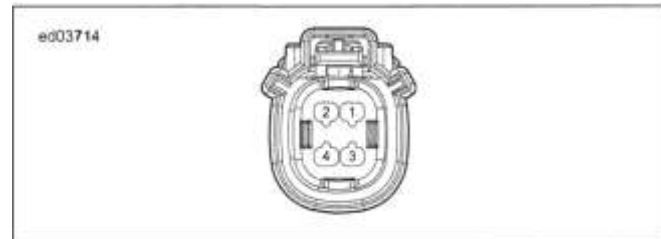


Figure A-182. HO2S Sensor 2 [340B]

Table A-150. TCU [339]

| TERMINAL | WIRE COLOR | CIRCUIT DESCRIPTION |
|----------|------------|---------------------|
| 1        | R/O        | Battery power       |
| 2        | BK/GN      | Ground              |
| 3        | W/BN       | Remote IMMOB        |
| 4        | W/BK       | CAN low             |
| 5        | W/R        | CAN high            |
| 6        | -          | N/C                 |

Table A-153. Fork Clamp Ground [GND3]

| TERMINAL | WIRE COLOR | CIRCUIT DESCRIPTION |
|----------|------------|---------------------|
| 1        | BK         | Ground              |

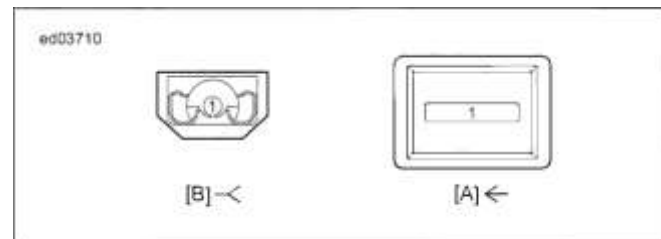


Figure A-183. Fork Clamp Ground [GND3]

## NOTES

| SUBJECT                    | PAGE NO. |
|----------------------------|----------|
| B.1 GLOSSARY .....         | B-1      |
| B.2 METRIC CONVERSION..... | B-4      |
| B.3 FLUID CONVERSION ..... | B-5      |



## NOTES



**ACRONYMS AND ABBREVIATIONS**

Refer to the table below for a list of common acronyms and abbreviations.

**Table B-1. Acronyms and Abbreviations**

| ACRONYM OR ABBREVIATION | DESCRIPTION   |
|-------------------------|---|
| A                       | Amperes   |
| AAT                     | Ambient air temperature                             |
| ABS                     | Anti-lock braking system                            |
| AC                      | Alternating current                                 |
| ACC                     | Accessory position on ignition switch               |
| ACR                     | Automatic compression release                       |
| AGM                     | Absorbed glass mat (battery)                        |
| Ah                      | Ampere-hour   |
| AIS                     | Active intake solenoid                              |
| AWG                     | American wire gauge                                 |
| B+                      | Battery voltage                                     |
| bar                     | Bar   |
| BAS                     | Bank angle sensor                                   |
| BCM                     | Body control module                                 |
| BMU                     | Battery Management Unit                             |
| BOB                     | Breakout box  |
| BTDC                    | Before top dead center                              |
| °C                      | Celsius (Centigrade)                                |
| CA                      | California  |
| CAL                     | Calibration   |
| CAN                     | Controller area network                             |
| CB Tx                   | CB send transmission                                |
| CB Rx                   | CB receive transmission                             |
| cc                      | Cubic centimeters                                   |
| CCA                     | Cold cranking amps                                  |
| CCW                     | Counterclockwise                                    |
| CKP                     | Crankshaft position                                 |
| cm                      | Centimeters   |
| cm <sup>3</sup>         | Cubic centimeters                                   |
| CW                      | Clockwise   |
| DC                      | Direct current                                      |
| DLC                     | Data link connector                                 |
| DOM                     | Domestic  |
| DOT                     | Department of Transportation                        |
| DTC                     | Diagnostic trouble code                             |
| DVOM                    | Digital volt ohm meter                              |
| ECM                     | Electronic control module                           |
| ECT                     | Engine coolant temperature                          |
| ECU                     | Electronic control unit                             |
| EEPROM                  | Electrically erasable programmable read only memory |
| EFI                     | Electronic fuel injection                           |
| EHCUC                   | Electro hydraulic control unit                      |
| EPTC                    | Electronic Powertrain Controller                    |
| ET                      | Engine temperature                                  |
| ETC                     | Electronic throttle control                         |
| EVAP                    | Evaporative emissions control system                |
| EVPT                    | Electric Vehicle Powertrain                         |
| °F                      | Fahrenheit  |
| fl oz                   | Fluid ounce   |
| FPS                     | Fuel pressure sensor                                |
| ft                      | Feet  |
| ft-lbs                  | Foot pounds   |
| FTP                     | Flash to pass                                       |
| g                       | Gram  |
| gal                     | Gallon  |

**Table B-1. Acronyms and Abbreviations**

| <b>ACRONYM OR ABBREVIATION</b> | <b>DESCRIPTION</b>                    |
|--------------------------------|---------------------------------------|
| GAWR                           | Gross axle weight rating              |
| GND                            | Ground (electrical)                   |
| GPS                            | Global positioning system             |
| GVWR                           | Gross vehicle weight rating           |
| HCU                            | Hydraulic control unit                |
| HDI                            | Harley-Davidson International         |
| HD-Link                        | Networking system                     |
| H-DSSS                         | Harley-Davidson smart security system |
| <b>HFM</b>                     | Hands-free mode                       |
| HFSM                           | Hands-free security module            |
| Hg                             | Mercury                               |
| H02S                           | Heated oxygen sensor                  |
| hp                             | Horsepower                            |
| hr                             | Hour                                  |
| IAC                            | Idle air control                      |
| IAT                            | Intake air temperature                |
| IC                             | Instrument cluster                    |
| ID                             | Inside diameter                       |
| IGN                            | Ignition light/key switch position    |
| <b>IM</b>                      | Instrument module                     |
| IMU                            | Inertial Measurement Unit             |
| in                             | inch                                  |
| in <sup>3</sup>                | Cubic inch                            |
| INJ PW                         | Injector pulse width                  |
| INTCM                          | Intercom                              |
| <b>in-lbs</b>                  | Inch pounds                           |
| JSS                            | Jiffy stand sensor                    |
| kg                             | Kilogram                              |
| km                             | Kilometer                             |
| km/h                           | Kilometers per hour                   |
| kPa                            | Kilopascal                            |
| kW                             | Kilowatt                              |
| KS                             | Knock sensor                          |
| L                              | Liter                                 |
| lb                             | Pounds                                |
| LCD                            | Liquid crystal display                |
| LED                            | Light emitting diode                  |
| LH                             | Left hand                             |
| LHCM                           | Left hand control module              |
| <b>LP</b>                      | License plate                         |
| <b>LT</b>                      | Left                                  |
| mA                             | Milliampere                           |
| <b>MAP</b>                     | Manifold absolute pressure            |
| max                            | Maximum                               |
| <b>MCM</b>                     | Motor Control Module                  |
| mi                             | Mile                                  |
| min                            | Minimum                               |
| mL                             | Milliliter                            |
| mm                             | Millimeter                            |
| mph                            | Miles per hour                        |
| ms                             | Millisecond                           |
| Nm                             | Newton-meter                          |
| <b>NIM</b>                     | Navigation interface module           |
| <b>NiMH</b>                    | Nickel metal hydride                  |
| <b>N/A</b>                     | Not applicable                        |
| <b>O<sub>2</sub></b>           | Oxygen                                |
| OBC                            | Onboard Charger                       |
| OD                             | Outside diameter                      |
| <b>OEM</b>                     | Original equipment manufacturer       |
| oz                             | Ounce                                 |
| P&A                            | Parts and Accessories                 |
| Part No.                       | Part number                           |
| <b>PIN</b>                     | Personal identification number        |

**Table B-1. Acronyms and Abbreviations**

| <b>ACRONYM OR ABBREVIATION</b> | <b>DESCRIPTION</b>                         |
|--------------------------------|--|
| PND                            | Personal navigation device                 |
| psi                            | Pounds per square inch                     |
| PWM signal                     | Pulse width modulated signal               |
| qt                             | Quart                                      |
| RAD                            | Radio                                      |
| RCM                            | Reverse control module                     |
| RDS                            | Radio data system                          |
| RES                            | Reserve mark on fuel supply valve          |
| RESS                           | Rechargeable Energy Storage System         |
| RH                             | Right hand                                 |
| RHCM                           | Right hand control module                  |
| rpm                            | Revolutions per minute                     |
| RT                             | Right                                      |
| s                              | Seconds                                    |
| SCFH                           | Cubic feet per hour at standard conditions |
| SDARS                          | Satellite digital audio radio service      |
| SPDO                           | Speedometer                                |
| SPKR                           | Speaker                                    |
| STT                            | Stop/tail/turn                             |
| TA                             | Traffic announcement                       |
| TCA                            | Throttle control actuator                  |
| TCU                            | Telemetry Control Unit                     |
| TDC                            | Top dead center                            |
| TGS                            | Twist grip sensor                          |
| TPMS                           | Tire pressure monitoring system            |
| TPS                            | Throttle position sensor                   |
| TSM                            | Turn signal module                         |
| TSSM                           | Turn signal/security module                |
| TT                             | Telltale                                   |
| USB                            | Universal serial bus                       |
| V                              | Volt                                       |
| VAC                            | Volts of alternating current               |
| VDC                            | Volts of direct current                    |
| VIN                            | Vehicle identification number              |
| VR                             | Voice recognition                          |
| VSC                            | Vehicle Security Advisory Controller       |
| VSS                            | Vehicle speed sensor                       |
| W                              | Watt                                       |
| WA                             | Weather alert                              |
| WHIM                           | Wireless headset interface module          |
| WSS                            | Wheel speed sensor                         |

**Table B-2. Metric Conversions**

| MILLIMETERS to INCHES<br>MM x 0.03937 = IN) |       |    |       |    |       |     |       | INCHES to MILLIMETERS (IN x 25.40 = MM) |        |         |        |         |       |         |        |
|---|-------|----|-------|----|-------|-----|-------|---|--------|---------|--------|---------|-------|---------|--------|
| mm  | in    | mm | in    | mm | in    | mm  | in    | in                                      | mm     | in      | mm     | in      | mm    | in      |        |
| .1  | .0039 | 25 | .9842 | 58 | 2.283 | 91  | 3.582 | .001                                    | .025   | .6      | 15.240 | 1-15/16 | 49.21 | 3-5/16  | 84.14  |
| .2  | .0078 | 26 | 1.024 | 59 | 2.323 | 92  | 3.622 | .002                                    | .051   | 5/8     | 15.875 | 2       | 50.80 | 3-3/8   | 85.72  |
| .3  | .0118 | 27 | 1.063 | 60 | 2.362 | 93  | 3.661 | .003                                    | .076   | 11/16   | 17.462 | 2-1/16  | 52.39 | 3.4     | 86.36  |
| .4  | .0157 | 28 | 1.102 | 61 | 2.401 | 94  | 3.701 | .004                                    | .102   | .7      | 17.780 | 2.1     | 53.34 | 3-7/16  | 87.31  |
| .5  | .0197 | 29 | 1.142 | 62 | 2.441 | 95  | 3.740 | .005                                    | .127   | 3/4     | 19.050 | 2-1/8   | 53.97 | 3-1/2   | 88.90  |
| .6  | .0236 | 30 | 1.181 | 63 | 2.480 | 96  | 3.779 | .006                                    | .152   | .8      | 20.320 | 2-3/16  | 55.56 | 3-9/16  | 90.49  |
| .7  | .0275 | 31 | 1.220 | 64 | 2.519 | 97  | 3.819 | .007                                    | .178   | 13/16   | 20.638 | 2.2     | 55.88 | 3.6     | 91.44  |
| .8  | .0315 | 32 | 1.260 | 65 | 2.559 | 98  | 3.858 | .008                                    | .203   | 7/8     | 22.225 | 2-1/4   | 57.15 | 3-5/8   | 92.07  |
| .9  | .0354 | 33 | 1.299 | 66 | 2.598 | 99  | 3.897 | .009                                    | .229   | .9      | 22.860 | 2.3     | 58.42 | 3-11/16 | 93.66  |
| 1   | .0394 | 34 | 1.338 | 67 | 2.638 | 100 | 3.937 | .010                                    | .254   | 15/16   | 23.812 | 2-5/16  | 58.74 | 3.7     | 93.98  |
| 2   | .0787 | 35 | 1.378 | 68 | 2.677 | 101 | 3.976 | 1/64                                    | .397   | 1       | 25.40  | 2-3/8   | 60.32 | 3-3/4   | 95.25  |
| 3   | .1181 | 36 | 1.417 | 69 | 2.716 | 102 | 4.016 | .020                                    | .508   | 1-1/16  | 26.99  | 2.4     | 60.96 | 3.8     | 96.52  |
| 4   | .1575 | 37 | 1.456 | 70 | 2.756 | 103 | 4.055 | .030                                    | .762   | 1.1     | 27.94  | 2-7/16  | 61.91 | 3-13/16 | 96.84  |
| 5   | .1968 | 38 | 1.496 | 71 | 2.795 | 104 | 4.094 | 1/32                                    | .794   | 1-1/8   | 28.57  | 2-1/2   | 63.50 | 3-7/8   | 98.42  |
| 6   | .2362 | 39 | 1.535 | 72 | 2.834 | 105 | 4.134 | .040                                    | 1.016  | 1-3/16  | 30.16  | 2-9/16  | 65.09 | 3.9     | 99.06  |
| 7   | .2756 | 40 | 1.575 | 73 | 2.874 | 106 | 4.173 | .050                                    | 1.270  | 1.2     | 30.48  | 2.6     | 66.04 | 3-15/16 | 100.01 |
| 8   | .3149 | 41 | 1.614 | 74 | 2.913 | 107 | 4.212 | .060                                    | 1.524  | 1-1/4   | 31.75  | 2-5/8   | 66.67 | 4       | 101.6  |
| 9   | .3543 | 42 | 1.653 | 75 | 2.953 | 108 | 4.252 | 1/16                                    | 1.588  | 1.3     | 33.02  | 2-11/16 | 68.26 | 4-1/16  | 102.19 |
| 10  | .3937 | 43 | 1.693 | 76 | 2.992 | 109 | 4.291 | .070                                    | 1.778  | 1-5/16  | 33.34  | 2.7     | 68.58 | 4.1     | 104.14 |
| 11  | .4331 | 44 | 1.732 | 77 | 3.031 | 110 | 4.331 | .080                                    | 2.032  | 1-3/8   | 34.92  | 2-3/4   | 69.85 | 4-1/8   | 104.77 |
| 12  | .4724 | 45 | 1.772 | 78 | 3.071 | 111 | 4.370 | .090                                    | 2.286  | 1.4     | 35.56  | 2.8     | 71.12 | 4-3/16  | 106.36 |
| 13  | .5118 | 46 | 1.811 | 79 | 3.110 | 112 | 4.409 | .1                                      | 2.540  | 1-7/16  | 36.51  | 2-13/16 | 71.44 | 4.2     | 106.68 |
| 14  | .5512 | 47 | 1.850 | 80 | 3.149 | 113 | 4.449 | 1/8                                     | 3.175  | 1-1/2   | 38.10  | 2-7/8   | 73.02 | 4-1/4   | 107.95 |
| 15  | .5905 | 48 | 1.890 | 81 | 3.189 | 114 | 4.488 | 3/16                                    | 4.762  | 1-9/16  | 39.69  | 2.9     | 73.66 | 4.3     | 109.22 |
| 16  | .6299 | 49 | 1.929 | 82 | 3.228 | 115 | 4.527 | .2                                      | 5.080  | 1.6     | 40.64  | 2-15/16 | 74.61 | 4-5/16  | 109.54 |
| 17  | .6693 | 50 | 1.968 | 83 | 3.268 | 116 | 4.567 | 1/4                                     | 6.350  | 1-5/8   | 41.27  | 3       | 76.20 | 4-3/8   | 111.12 |
| 18  | .7086 | 51 | 2.008 | 84 | 3.307 | 117 | 4.606 | .3                                      | 7.620  | 1-11/16 | 42.86  | 3-1/16  | 77.79 | 4.4     | 111.76 |
| 19  | .7480 | 52 | 2.047 | 85 | 3.346 | 118 | 4.645 | 5/16                                    | 7.938  | 1.7     | 43.18  | 3.1     | 78.74 | 4-7/16  | 112.71 |
| 20  | .7874 | 53 | 2.086 | 86 | 3.386 | 119 | 4.685 | 3/8                                     | 9.525  | 1-3/4   | 44.45  | 3-1/8   | 79.37 | 4-1/2   | 114.30 |
| 21  | .8268 | 54 | 2.126 | 87 | 3.425 | 120 | 4.724 | .4                                      | 10.160 | 1.8     | 45.72  | 3-3/16  | 80.96 | 4-9/16  | 115.89 |
| 22  | .8661 | 55 | 2.165 | 88 | 3.464 | 121 | 4.764 | 7/16                                    | 11.112 | 1-13/16 | 46.04  | 3.2     | 81.28 | 4.6     | 116.84 |
| 23  | .9055 | 56 | 2.205 | 89 | 3.504 | 122 | 4.803 | 1/2                                     | 12.700 | 1-7/8   | 47.62  | 3-1/4   | 82.55 | 4-5/8   | 117.47 |
| 24  | .9449 | 57 | 2.244 | 90 | 3.543 | 123 | 4.842 | 9/16                                    | 14.288 | 1.9     | 48.26  | 3.3     | 83.82 | 4-11/16 | 119.06 |

**UNITED STATES SYSTEM \_\_\_\_\_ BRITISH IMPERIAL SYSTEM**

Unless otherwise specified, all fluid volume measurements in this manual are expressed in United States (U.S.) units-of-measure. See below:

- 1 pint (U.S.) = 16 fluid ounces (U.S.)
- 1 quart (U.S.) = 2 pints (U.S.) = 32 fl. oz. (U.S.)
- 1 gallon (U.S.) = 4 quarts (U.S.) = 128 fl. oz. (U.S.)

**METRIC SYSTEM \_\_\_\_\_**

Fluid volume measurements in this manual include the metric system equivalents. In the metric system, 1 liter (L) = 1,000 milliliters (mL). To convert between U.S. units-of-measure and metric units-of-measure, refer to the following:

- fluid ounces (U.S.) x 29.574 = milliliters
- pints (U.S.) x 0.473 = liters
- quarts (U.S.) x 0.946 = liters
- gallons (U.S.) x 3.785 = liters
- milliliters x 0.0338 = fluid ounces (U.S.)
- liters x 2.114 = pints (U.S.)
- liters x 1.057 = quarts (U.S.)
- liters x 0.264 = gallons (U.S.)

Fluid volume measurements in this manual do not include the British Imperial (Imp.) system equivalents. The following conversions exist in the British Imperial system:

- 1 pint (Imp.) = 20 fluid ounces (Imp.)
- 1 quart (Imp.) = 2 pints (Imp.)
- 1 gallon (Imp.) = 4 quarts (Imp.)

Although the same unit-of-measure terminology as the U.S. system is used in the British Imperial (Imp.) system, the actual volume of each British Imperial unit-of-measure differs from its U.S. counterpart. The U.S. fluid ounce is larger than the British Imperial fluid ounce. However, the U.S. pint, quart, and gallon are smaller than the British Imperial pint, quart, and gallon, respectively. To convert between U.S. units and British Imperial units, refer to the following:

- fluid ounces (U.S.) x 1.042 = fluid ounces (Imp.)
- pints (U.S.) x 0.833 = pints (Imp.)
- quarts (U.S.) x 0.833 = quarts (Imp.)
- gallons (U.S.) x 0.833 = gallons (Imp.)
- fluid ounces (Imp.) x 0.960 = fluid ounces (U.S.)
- pints (Imp.) x 1.201 = pints (U.S.)
- quarts (Imp.) x 1.201 = quarts (U.S.)
- gallons (Imp.) x 1.201 = gallons (U.S.)





## NOTES

# TOOLS

| Part Number | TOOLNAME  | NOTES   |
|-------------|---|---|
| 93979-10    | MAGNETIC LIFTER HOLDERS                                       | 4.21 CAM COMPARTMENT AND COMPONENTS, Remove   |
| 94086-09    | PUSHROD TUBE CLIP REMOVER AND INSTALLER                       | 4.17 PUSHRODS, LIFTERS AND COVERS, Remove<br>4.17 PUSHRODS, LIFTERS AND COVERS, Install   |
| 94686-00    | OIL FILTER WRENCH   | 2.5 REPLACE ENGINE OIL AND FILTER, Change Oil and Oil Filter  |
| 94863-10    | OIL FILTER WRENCH   | 2.5 REPLACE ENGINE OIL AND FILTER, Change Oil and Oil Filter  |
| B-45525     | VALVE GUIDE HONE  | 4.18 CYLINDER HEADS, Clean and Inspect  |
| B-49312     | CYLINDER HEAD HOLDING FIXTURE                                 | 4.18 CYLINDER HEADS, Disassemble<br>4.18 CYLINDER HEADS, Assemble   |
| BB200A      | BASIC VACUUM BRAKE BLEEDER                                    | 2.11 CHECK AND REPLACE BRAKE FLUID, Drain and Replace Fluid<br>3.18 BRAKE LINES, Brake Line: Front Master Cylinder to ABS Module<br>3.18 BRAKE LINES, Brake Line: Front Caliper to ABS Module<br>3.18 BRAKE LINES, Brake Line: Rear Master Cylinder to ABS Module<br>BRAKE LINES, Brake Line: Rear Caliper to ABS Module<br>ABS MODULE, Prepare<br>BLEED BRAKES, Drain<br>3.20 BLEED BRAKES, Fill and Bleed |
| FRX181      | FLARE NUT SOCKET  | HEADLAMP, Adjust<br>AUXILIARY LAMPS, Remove<br>8.23 AUXILIARY LAMPS, Install  |
| HD-23688    | BATTERY TESTER  | 7.4 DIAGNOSE AND TEST, Freeze Point Test  |
| HD-25070    | ROBINAIR HEAT GUN   | 3.35 WINDSHIELD, Disassemble<br>3.48 TOUR-PAK, Disassemble and Assemble<br>4.24 CRANKCASE, Sprocket Shaft Bearing Inner Race  |
| HD-26568    | BATTERY TESTER  | 7.4 DIAGNOSE AND TEST, Freeze Point Test  |
| HD-29545-6A | COOLANT FLUORESCENT LEAK DETECTION DYE                        | 7.4 DIAGNOSE AND TEST, Leak Detection Dye Test  |
| HD-33223-1  | CYLINDER COMPRESSION GAUGE                                    | 4.7 TROUBLESHOOTING, Compression Test   |
| HD-34736-B  | VALVE SPRING COMPRESSOR                                       | 4.18 CYLINDER HEADS, Disassemble<br>4.18 CYLINDER HEADS, Assemble   |
| HD-34751    | CLEANING BRUSH  | 4.18 CYLINDER HEADS, Clean and Inspect<br>4.18 CYLINDER HEADS, Assemble   |
| HD-34902-B  | BIG-TWIN MAINSHAFT PRIMARY BEARING RACE REMOVER AND INSTALLER | 4.24 CRANKCASE, Sprocket Shaft Bearing Inner Race   |
| HD-34902-C  | BEARING RACE REMOVER AND INSTALLER KIT                        | 5.11 PRIMARY CHAINCASE HOUSING, Mainshaft Bearing Inner Race  |
| HD-35316-D  | MAIN DRIVE GEAR REMOVER AND INSTALLER SET                     | 5.14 MAIN DRIVE GEAR AND BEARING, Remove<br>5.14 MAIN DRIVE GEAR AND BEARING, Install   |
| HD-35381-A  | BELT TENSION GAUGE  | 2.18 INSPECT AND ADJUST DRIVE BELT AND SPROCKETS, Measure Drive Belt Deflection   |
| HD-35457    | BLACK LIGHT LEAK DETECTOR                                     | 7.4 DIAGNOSE AND TEST, Leak Detection Dye Test  |
| HD-35667-A  | CYLINDER LEAKDOWN TESTER                                      | 4.7 TROUBLESHOOTING, Cylinder Leakdown Test   |
| HD-35801    | INTAKE MANIFOLD SCREWDRIVER                                   | 6.17 INDUCTION MODULE, Remove<br>6.17 INDUCTION MODULE, Install   |
| HD-41137    | HOSE CLAMP PLIERS   | 4.8 CRIMP CLAMPS, Install<br>4.11 OIL COOLANT LINES, Remove   |
| HD-41177    | FORK TUBE HOLDER  | 3.23 FRONT FORK, Disassemble  |

## TOOLS

| Part Number  | TOOL NAME  | NOTES  |
|--------------|--|--|
|              |  | 3.23 FRONT FORK, Assemble  |
| HD-41182     | FUEL PRESSURE GAUGE                                | 6.5 FUEL PRESSURE TEST, Test   |
| HD-41417     | PROPANE ENRICHMENT KIT                             | 6.18 INTAKE LEAK TEST, Leak Tester   |
| HD-42320-D   | PISTON PIN EXTRACTOR                               | 4.20 PISTONS, Remove   |
| HD-42325-C   | CAMSHAFT NEEDLE BEARING REMOVER/INSTALLER          | 4.21 CAM COMPARTMENT AND COMPONENTS, Camshaft Needle Bearings  |
| HD-42326-B   | CRANKSHAFT GUIDE                                   | 4.24 CRANKCASE, Assemble   |
| HD-44060-1QA | COLLET   | 3.9 SEALED WHEEL BEARINGS, Remove  |
| HD-44060-11A | COLLET   | 3.9 SEALED WHEEL BEARINGS, Remove  |
| HD-44060D    | WHEEL BEARING INSTALLER/REMOVER                    | 3.9 SEALED WHEEL BEARINGS, Remove<br>3.9 SEALED WHEEL BEARINGS, Install  |
| HD-44061     | FUEL PRESSURE GAUGE ADAPTER                        | 6.5 FUEL PRESSURE TEST, Test   |
| HD-44358     | FLYWHEEL SUPPORT FIXTURE                           | 4.24 CRANKCASE, Sprocket Shaft Bearing Inner Race  |
| HD-45322     | VALVE GUIDE SEAL INSTALLER                         | 4.18 CYLINDER HEADS, Assemble  |
| HD-45327     | REAR SWINGARM BEARING INSTALLER                    | 3.25 REAR FORK, Assemble   |
| HD-45335     | COOLANT SYSTEM PRESSURE TESTER                     | 7.4 DIAGNOSE AND TEST, Pressure Cap Test<br>7.4 DIAGNOSE AND TEST, System Pressure Test<br>7.4 DIAGNOSE AND TEST, Gasket Leak Test   |
| HD-45968     | FAT JACK   | 2.2 GENERAL, Secure the Motorcycle for Service<br>4.23 REPLACE ENGINE, Remove  |
| HD-46282A    | FINAL DRIVE SPROCKET LOCKING TOOL                  | 5.12 TRANSMISSION SPROCKET, Remove<br>5.12 TRANSMISSION SPROCKET, Install  |
| HD-47856     | MAIN DRIVE GEAR SEAL INSTALLER KIT                 | 5.14 MAIN DRIVE GEAR AND BEARING, Install  |
| HD-47910     | MAINSHAFT LOCKNUT WRENCH                           | 5.12 TRANSMISSION SPROCKET, Remove<br>5.12 TRANSMISSION SPROCKET, Install  |
| HD-47925     | AXLE NUT TORQUE ADAPTER                            | 2.18 INSPECT AND ADJUST DRIVE BELT AND SPROCKETS, Adjust Belt<br>3.5 REAR WHEEL, Remove  |
| HD-47932     | MAIN DRIVE GEAR BEARING AND SEAL INSTALLATION TOOL | 5.14 MAIN DRIVE GEAR AND BEARING, Replace Needle Bearings  |
| HD-47933     | MAIN DRIVE GEAR SEAL INSTALLER                     | 5.14 MAIN DRIVE GEAR AND BEARING, Replace Mainshaft Seal   |
| HD-47941     | CRANKSHAFT/CAMSHAFT SPROCKET LOCKING TOOL          | 4.21 CAM COMPARTMENT AND COMPONENTS, Remove<br>4.21 CAM COMPARTMENT AND COMPONENTS, Install  |
| HD-48219     | PRIMARY DRIVE LOCKING TOOL                         | 5.9 DRIVE COMPONENTS, Remove<br>5.9 DRIVE COMPONENTS, Install  |
| HD-48497-A   | DOT 4 BRAKE FLUID MOISTURE TESTER                  | INSPECT BRAKES, Inspect<br>CHECK AND REPLACE BRAKE FLUID, Check Brake Fluid Level  |
| HD-48498-B-1 | ACR SOLENOID SOCKET                                | 8.52 AUTOMATIC COMPRESSION RELEASE (ACR), Install  |
| HD-48646     | CAM RING REMOVER/INSTALLER                         | 6.9 FUEL TANK TOP PLATE, Remove<br>6.9 FUEL TANK TOP PLATE, Install  |
| HD-48650     | DIGITAL TECHNICIAN II                              | 2.11 CHECK AND REPLACE BRAKE FLUID, Drain and Replace Fluid<br>3.10 TIRE PRESSURE MONITORING SYSTEM (TPMS), Complete<br>ABS MODULE, Install<br>BLEED BRAKES, Fill and Bleed<br>6.6 PURGE FUEL LINE, Purge<br>8.32 RADIO, Complete<br>8.40 ELECTRONIC CONTROL MODULE (ECM), Install |

## TOOLS

| Part Number  | TOOL NAME   | NOTES  |
|--------------|---|--|
|              |   | BODY CONTROL MODULE (BCM), Install<br>SECURITY SYSTEM ACTIVATION, Fob Assignment<br>8.44 SECURITY SYSTEM MAINTENANCE, Service Mode   |
| HD-48921     | REAR WHEEL COMPENSATOR SPROCKET BEARING REMOVER/INSTALLER | 3.8 REAR WHEEL COMPENSATOR, Disassemble<br>3.8 REAR WHEEL COMPENSATOR, Assemble  |
| HD-48985     | SPOKE TORQUE WRENCH                                       | 2.8 INSPECT TIRES AND WHEELS, Wheel Spokes   |
| HD-50549     | BORESCOPE   | 4.7 TROUBLESHOOTING, Compression Test<br>4.7 TROUBLESHOOTING, Cylinder Leakdown Test   |
| HD-51069     | PISTON PIN CLIP REMOVER/INSTALLER KIT                     | 4.20 PISTONS, Remove   |
| HD-51069-17  | NOSE ADAPTER  | 4.20 PISTONS, Install  |
| HD-51069-2   | PISTON PIN RETAINING RING INSTALLER                       | 4.20 PISTONS, Install  |
| HD-51198     | IGNITION SWITCH ALIGNMENT TOOL                            | 8.9 IGNITION SWITCH, Remove and Install: Fairing Models  |
| HD-51337     | SHIFTER SHAFT SEAL INSTALLATION TOOL                      | 5.15 TRANSMISSION CASE, Assemble   |
| HD-51656     | DIN CONNECTOR TOOL  | 8.34 REAR SPEAKERS, Disassemble<br>8.34 REAR SPEAKERS, Assemble<br>8.36 RIDER HEADSET CONNECTOR, Remove<br>8.36 RIDER HEADSET CONNECTOR, Install   |
| HD-51727     | STEERING HEAD BEARING INSTALLER                           | 3.24 STEERING HEAD/FORK STEM AND BRACKET ASSEMBLY, Install   |
| HD-51794     | TPMS ACTIVATION TOOL                                      | 3.10 TIRE PRESSURE MONITORING SYSTEM (TPMS), Complete  |
| HD-52004     | 24 INCH HOSE CLAMP TOOL                                   | 7.5 COOLANT, Drain and Fill Cooling System<br>7.8 COOLANT HOSES, Remove and Install: Horizontal Tube<br>7.8 COOLANT HOSES, Remove and Install: Coolant Lines<br>7.8 COOLANT HOSES, Remove and Install: Coolant Downtubes |
| HD-52006     | ADJUSTABLE SPARK PLUG WIRE PULLER                         | 2.24 CLEAN AND INSPECT SPARK PLUGS, Remove<br>8.10 SPARK PLUG CABLES, Remove   |
| HD-52020     | CYLINDER HOLD-DOWN NUTS                                   | 4.19 CYLINDERS, Install  |
| HD-52064     | LEFT MAIN BEARING OIL SEAL INSTALLATION TOOL              | 4.24 CRANKCASE, Assemble   |
| HD-52065     | BALANCER SCISSOR GEAR ALIGNMENT TOOL                      | 4.24 CRANKCASE, Disassemble<br>4.24 CRANKCASE, Assemble  |
| HD-52071     | MAIN BEARING REMOVER AND INSTALLER                        | 4.24 CRANKCASE, Repair Right Crankcase Half<br>4.24 CRANKCASE, Repair Left Crankcase Half  |
| HD-52073     | ALTERNATOR ROTOR REMOVER AND INSTALLER                    | 8.7 ALTERNATOR, Remove<br>8.7 ALTERNATOR, Install  |
| HD-52185     | PISTON SUPPORT PLATE                                      | 4.19 CYLINDERS, Install  |
| HD-52252     | CRANKSHAFT LOCKING TOOL                                   | 4.7 TROUBLESHOOTING, Cylinder Leakdown Test  |
| HD-52977     | 17MM OXYGEN SENSOR SOCKET                                 | 6.19 HEATED OXYGEN SENSORS (HO2S), Remove<br>6.19 HEATED OXYGEN SENSORS (HO2S), Install  |
| HD-59000B    | FORK OIL LEVEL GAUGE                                      | 3.23 FRONT FORK, Assemble  |
| HD-94660-2   | PILOT   | 5.12 TRANSMISSION SPROCKET, Remove<br>5.12 TRANSMISSION SPROCKET, Install  |
| HD-94681-80  | SPOKE WRENCH  | 2.8 INSPECT TIRES AND WHEELS, Wheel Spokes   |
| HD-95637-46B | WEDGE ATTACHMENT  | 4.24 CRANKCASE, Sprocket Shaft Bearing Inner Race  |



## TOOLS

| Part Number   | TOOLNAME                                     | NOTES   |
|---------------|--|---|
| HD-96333-51 F | PISTON RING COMPRESSOR                       | 4.19 CYLINDERS, Install   |
| HD-96921-52D  | OIL PRESSURE TEST GAUGE KIT                  | 4.6 OIL PRESSURE, Oil Pressure Check  |
| HD-97225-55C  | SPROCKET SHAFT BEARING INSTALLER             | 4.24 CRANKCASE, Assemble<br>4.24 CRANKCASE, Sprocket Shaft Bearing Inner Race |
| HD-99500-80   | WHEEL TRUING STAND                           | 3.7 CHECKING AND TRUING WHEELS, Checking Wheel Runout                         |
| MCR102A       | MATCO VACUUM VENTURI COOLING SYSTEM REFILLER | 7.5 COOLANT, Drain and Fill Cooling System                                    |
| MPT10128      | COOLING SYSTEM ADAPTER                       | 7.5 COOLANT, Drain and Fill Cooling System                                    |
| TA360         | TORQUE ANGLE GAUGE                           | 5.12 TRANSMISSION SPROCKET, Install   |

## Torque Values

| FASTENER  | TORQUE VALUE     |               | NOTES  |
|---|------------------|---------------|--|
| Temperature manifold absolute pressure (TMAP) screw                       | 22-40 in-lbs     | 2.5-4.5 N-m   | 6.14 TEMPERATURE MANIFOLD ABSOLUTE PRESSURE (TMAP) SENSOR, Install                     |
| ABS module banjo bolt   | 28-30 ft-lbs     | 38-40.6 N-m   | 3.18 BRAKE LINES, Brake Line: Front Master Cylinder to ABS Module                      |
| ABS module locknuts   | 53-89 in-lbs     | 6-10 N-m      | 3.19 ABS MODULE, Install   |
| ACR   | 17-19 ft-lbs     | 23-26.4 N-m   | 8.52 AUTOMATIC COMPRESSION RELEASE (ACR), Install                                      |
| AM/FM antenna stud nut  | 16-19 in-lbs     | 1.8-2.1 N-m   | 8.29 TOUR-PAK LIGHTING, Remove and Install: Wrap-Around Lamp                           |
| Accessory switch module screw   | 12-17 in-lbs     | 1.4-1.9 N-m   | 8.14 ACCESSORY SWITCHES, Remove and Install: Frame Mounted Fairing                     |
| Accessory switch module screw   | 12-17 in-lbs     | 1.4-1.9 N-m   | 8.14 ACCESSORY SWITCHES, Remove and Install: Fork Mounted Fairing                      |
| Air cleaner backplate screws, oval  | 55-60 in-lbs     | 6.2-6.8 N-m   | 6.3 AIR CLEANER BACKPLATE ASSEMBLY, Install  |
| Air cleaner breather bolts, oval  | 22-24 ft-lbs     | 29.8-32.5 N-m | 6.3 AIR CLEANER BACKPLATE ASSEMBLY, Install  |
| Air cleaner breather bolts, standard                                      | 22-24 ft-lbs     | 29.8-32.5 N-m | 6.3 AIR CLEANER BACKPLATE ASSEMBLY, Install  |
| Air cleaner cover screw   | 36-60 in-lbs     | 4.1-6.8 N-m   | 2.22 INSPECT AIR FILTER, Install<br>Apply LOCTITE 243 (blue) to the threads of screw.  |
| Air cleaner insert screws   | 27-32 in-lbs     | 3.1-3.6 N-m   | 2.22 INSPECT AIR FILTER, Install   |
| Air duct nut, lower fairing   | 65-75 in-lbs     | 7.3-8.4 N-m   | 8.47 COOLING FAN, Install  |
| Air duct screws, lower fairing  | 65-75 in-lbs     | 7.3-8.4 N-m   | 8.47 COOLING FAN, Install  |
| Air filter element screws, standard                                       | 40-60 in-lbs     | 4.5-6.8 N-m   | 6.3 AIR CLEANER BACKPLATE ASSEMBLY, Install  |
| Air filter element screws, oval   | 50-60 in-lbs     | 5.6-6.8 N-m   | 2.22 INSPECT AIR FILTER, Install<br>Apply LOCTITE 243 (blue) to the threads of screws. |
| Air filter element screws, standard                                       | 40-60 in-lbs     | 4.5-6.8 N-m   | 2.22 INSPECT AIR FILTER, Install   |
| Auxiliary/fog lamp door screw   | 10-14 in-lbs     | 1.1-1.6 N-m   | 8.23 AUXILIARY LAMPS, Bulb Replacement   |
| Auxiliary/fog lamp flange nut: Models with bullet style turn signal lamps | 20-24 ft-lbs     | 27.1-32.5 N-m | 8.22 HEADLAMP, Adjust  |
| Auxiliary/fog lamp flange nut: Models with flat lens turn signal lamps    | 15-18 ft-lbs     | 20.3-24.4 N-m | 8.22 HEADLAMP, Adjust  |
| Auxiliary/fog lamp stud locknut   | 20-24 ft-lbs     | 27.1-32.5 N-m | 8.23 AUXILIARY LAMPS, Install  |
| Balancer bearing screw  | 80-110 in-lbs    | 9-12.4 N-m    | 4.24 CRANKCASE, Repair Right Crankcase Half  |
| Banjo bolt to ABS module, 10 mm   | 17-19 ft-lbs     | 23.1-25.8 N-m | 3.19 ABS MODULE, Install   |
| Banjo bolt to ABS module, 12 mm   | 28-30 ft-lbs     | 38-40.6 N-m   | 3.18 BRAKE LINES, Brake Line: Rear Master Cylinder to ABS Module                       |
| Banjo bolt to ABS module, mm  | 17.0-19.0 ft-lbs | 23.1-25.8 N-m | 3.18 BRAKE LINES, Brake Line: Rear Caliper to ABS Module                               |
| Banjo bolt to rear caliper  | 17.0-19.0 ft-lbs | 23.1-25.8 N-m | 3.18 BRAKE LINES, Brake Line: Rear Caliper to ABS Module                               |
| Banjo bolt to rear master cylinder  | 17 ft-lbs        | 23.1 N-m      | 3.18 BRAKE LINES, Brake Line: Rear Master Cylinder to ABS Module                       |
| Battery cables screws   | 60-70 in-lbs     | 6.8-7.9 N-m   | 2.23 INSPECT BATTERY, Install  |
| Battery ground cable to transmission                                      | 66-114 in-lbs    | 7.5-12.9 N-m  | 5.15 TRANSMISSION CASE, Install  |
| Battery hold-down screws  | 32-40 in-lbs     | 3.6-4.5 N-m   | 8.11 IGNITION COIL, Install  |
| Battery tray screws   | 132-156 in-lbs   | 14.9-17.6 N-m | 3.19 ABS MODULE, Install   |
| Battery tray to frame screw   | 11-13 ft-lbs     | 14.9-17.6 N-m | 8.62 BATTERY TRAY, Install   |

## Torque Values

| FASTENER   | TORQUE VALUE   |               | NOTES  |
|--|----------------|---------------|--|
| Brake bleeder screw, front                           | 72-108 in-lbs  | 8.1-12.2 N-m  | 2.11 CHECK AND REPLACE BRAKE FLUID, Drain and Replace Fluid  |
| Brake bleeder screw, rear                            | 75-102 in-lbs  | 8.5-11.5 N-m  | 2.11 CHECK AND REPLACE BRAKE FLUID, Drain and Replace Fluid  |
| Brake caliper screw                                  | 43-48 ft-lbs   | 58-65 N-m     | 3.5 REAR WHEEL, Complete   |
| Brake disc screw, front                              | 16-24 ft-lbs   | 21.5-32.5 N-m | 3.4 FRONT WHEEL, Assemble<br>Always use new screws   |
| Brake line bracket to lower fork bracket screws      | 12-18 in-lbs   | 1.4-2 N-m     | 3.24 STEERING HEAD/FORK STEM AND BRACKET ASSEMBLY, Install   |
| Brake line, rear, P-clamp screw                      | 80-100 in-lbs  | 9-11.3 N-m    | 3.18 BRAKE LINES, Brake Line: Rear Master Cylinder to ABS Module   |
| Brake master cylinder, front, clamp screw            | 60-80 in-lbs   | 6.8-9 N-m     | 3.37 HANDLEBAR, Remove and Install: Without Fairing  |
| Brake master cylinder, front, reservoir cover screws | 12-15 in-lbs   | 1.4-1.7 N-m   | 2.11 CHECK AND REPLACE BRAKE FLUID, Drain and Replace Fluid  |
| Brake master cylinder, rear, reservoir cover screws  | 12-15 in-lbs   | 1.4-1.7 N-m   | 2.11 CHECK AND REPLACE BRAKE FLUID, Drain and Replace Fluid  |
| Brake pad pin  | 75-102 in-lbs  | 8.5-11.5 N-m  | 2.10 INSPECT BRAKES, Replace Front Brake Pads  |
| Brake pedal shaft locknut                            | 180-240 in-lbs | 20.3-27.1 N-m | 3.15 REAR BRAKE MASTER CYLINDER, Install   |
| Breather screw                                       | 90-120 in-lbs  | 10.2-13.6 N-m | 4.14 BREATHERS, Install  |
| CB antenna base set screw                            | 14-16 in-lbs   | 1.6-1.8 N-m   | 8.29 TOUR-PAK LIGHTING, Remove and Install: Wrap-Around Lamp   |
| CB antenna stud nut                                  | 14-16 in-lbs   | 1.6-1.8 N-m   | 8.29 TOUR-PAK LIGHTING, Remove and Install: Wrap-Around Lamp   |
| CB module bracket to speaker enclosure screw         | 25-35 in-lbs   | 2.8-4 N-m     | 8.37 CB MODULE, Install  |
| CKP mount screw                                      | 90-120 in-lbs  | 10.2-13.6 N-m | 8.49 CRANKSHAFT POSITION SENSOR (CKP), Install   |
| Cam chain tensioner fasteners                        | 90-120 in-lbs  | 10.2-13.6 N-m | 4.21 CAM COMPARTMENT AND COMPONENTS, Install   |
| Cam needle bearing installation maximum torque       | 25 ft-lbs      | 33.9 N-m      | 4.21 CAM COMPARTMENT AND COMPONENTS, Camshaft Needle Bearings  |
| Cam support plate screws                             | 90-120 in-lbs  | 10.2-13.6 N-m | 4.21 CAM COMPARTMENT AND COMPONENTS, Install   |
| Camshaft cover screws                                | 90-120 in-lbs  | 10.2-13.6 N-m | 4.21 CAM COMPARTMENT AND COMPONENTS, Remove and Install: Camshaft Cover  |
| Camshaft sprocket screw, 1st torque                  | 15.0 ft-lbs    | 20.3 N-m      | 4.21 CAM COMPARTMENT AND COMPONENTS, Install<br>See procedure to verify alignment specification before tightening. Apply LOCTITE 262 HIGH STRENGTH THREADLOCKER AND SEALANT (red). |
| Camshaft sprocket screw, alignment check torque      | 15.0 ft-lbs    | 20.3 N-m      | 4.21 CAM COMPARTMENT AND COMPONENTS, Install<br>See procedure to verify alignment specification before tightening.   |
| Camshaft sprocket screw, final torque                | 34 ft-lbs      | 46.1 N-m      | 4.21 CAM COMPARTMENT AND COMPONENTS, Install   |
| Camshaft timer cover screws                          | 25-35 in-lbs   | 2.8-4 N-m     | 4.21 CAM COMPARTMENT AND COMPONENTS, Remove and Install: Camshaft Cover  |
| Charcoal canister                                    | 15-20 in-lbs   | 1.7-2.3 N-m   | 6.23 CHARCOAL CANISTER: EVAPORATIVE EMISSIONS, Install   |



## Torque Values

| FASTENER  | TORQUE VALUE   |                | NOTES  |
|---|----------------|----------------|--|
| Clutch cable fitting  | 90-120 in-lbs  | 10.2-13.6 N-m  | 5.6 CLUTCH RELEASE COVER, Install  |
| Clutch hand lever screw   | 60-80 in-lbs   | 6.8-9 N-m      | 3.28 CLUTCH CONTROL, Install   |
| Clutch hub jamnut   | 72-120 in-lbs  | 8.1-13.6 N-m   | 2.12 CHECK AND ADJUST CLUTCH, Check and Adjust   |
| Clutch hub mainshaft nut  | 70-80 ft-lbs   | 94.9-108.5 N-m | 5.9 DRIVE COMPONENTS, Install  |
| Clutch inspection cover screws                                    | 84-108 in-lbs  | 9.5-12.2 N-m   | 2.6 REPLACE PRIMARY CHAINCASE LUBRICANT, Change Primary Chaincase Lubricant<br>Torque sequence   |
| Clutch lever anti-rattle screw                                    | 19-23 in-lbs   | 2.1-2.6 N-m    | 3.28 CLUTCH CONTROL, Assemble  |
| Clutch lever bracket clamp screw                                  | 60-80 in-lbs   | 6.8-9 N-m      | 3.37 HANDLEBAR, Remove and Install: Without Fairing  |
| Clutch release cover screws                                       | 132-156 in-lbs | 14.9-17.6 N-m  | 5.6 CLUTCH RELEASE COVER, Install  |
| Compensating sprocket bolt, 1st torque                            | 100 ft-lbs     | 135.6 N-m      | 5.9 DRIVE COMPONENTS, Install<br>Loosen then final tighten   |
| Compensating sprocket bolt, final torque                          | 175 ft-lbs     | 237.3 N-m      | 5.9 DRIVE COMPONENTS, Install  |
| Console screw (Front)   | 20-30 in-lbs   | 2.3-3.4 N-m    | 6.4 CONSOLE, Install   |
| Console screw (Rear)  | 40-60 in-lbs   | 4.1-6.8 N-m    | 6.4 CONSOLE, Install   |
| Coolant bottle nut  | 65-74 in-lbs   | 7.3-8.4 N-m    | 8.47 COOLING FAN, Complete   |
| Coolant down tube upper screws (2)                                | 90-110 in-lbs  | 10.2-12.4 N-m  | 3.33 ENGINE GUARD, Install   |
| Coolant downtube lower screws                                     | 20-22 ft-lbs   | 27.1-29.8 N-m  | 4.9 OIL COOLER, Install  |
| Coolant downtube upper screws                                     | 90-110 in-lbs  | 10.2-12.4 N-m  | 4.9 OIL COOLER, Install  |
| Coolant line manifold screws                                      | 90-120 in-lbs  | 10.2-13.6 N-m  | 7.8 COOLANT HOSES, Remove and Install: Coolant Lines   |
| Coolant overflow tank nut   | 65-74 in-lbs   | 7.3-8.4 N-m    | 7.7 COOLANT OVERFLOW TANK, Install   |
| Crankcase oil check valve or plug with O-ring                     | 18-22 ft-lbs   | 24.4-29.8 N-m  | 4.10 OIL CHECK VALVE, Install  |
| Crankcase screws, 1st torque                                      | 120 in-lbs     | 13.6 N-m       | 4.24 CRANKCASE, Assemble   |
| Crankcase screws, final torque                                    | 15-19 ft-lbs   | 20.3-25.8 N-m  | 4.24 CRANKCASE, Assemble   |
| Crankcase tapered plugs   | 120-144 in-lbs | 13.6-16.3 N-m  | 4.24 CRANKCASE, Plugs and Oil Fittings   |
| Crankshaft sprocket screw, 1st torque                             | 15.0 ft-lbs    | 20.3 N-m       | 4.21 CAM COMPARTMENT AND COMPONENTS, Install<br>Apply LOCTITE 262 HIGH STRENGTH THREADLOCKER AND SEALANT (red)   |
| Crankshaft sprocket screw, alignment check torque                 | 15.0 ft-lbs    | 20.3 N-m       | 4.21 CAM COMPARTMENT AND COMPONENTS, Install<br>See procedure to verify alignment specification before tightening.   |
| Crankshaft sprocket screw, final torque                           | 24 ft-lbs      | 32.5 N-m       | 4.21 CAM COMPARTMENT AND COMPONENTS, Install   |
| Cylinder head nut torque step 1.                                  | 20-30 ft-lbs   | 27.1-40.7 N-m  | 4.18 CYLINDER HEADS, Install<br>Apply ENGINE OIL to cylinder head bolt washers and threaded portion of the new cylinder head bolts. See procedure for torque sequence. |
| Cylinder head nut torque step 2. Loosen one turn.                 | -360°          | -360°          | 4.18 CYLINDER HEADS, Install   |
| Cylinder head nut torque step 3.                                  | 9-11 ft-lbs    | 12.2-14.9 N-m  | 4.18 CYLINDER HEADS, Install   |
| Cylinder head nut torque step 4.                                  | 25-27 ft-lbs   | 33.9-36.6 N-m  | 4.18 CYLINDER HEADS, Install   |
| Cylinder head nut torque step 5. Tighten additional degree value. | 90°            | 90°            | 4.18 CYLINDER HEADS, Install   |
| Cylinder stud   | 120-240 in-lbs | 13.6-27.1 N-m  | 4.24 CRANKCASE, Cylinder Studs   |
| Dash panel screw  | 25-30 in-lbs   | 2.8-3.4 N-m    | 8.64 FAIRING WIRE HARNESS, Remove and Install: Fork Mounted Fairing  |
| Debris deflector screw  | 65-85 in-lbs   | 7.3-9.6 N-m    | 3.25 REAR FORK, Complete   |

## Torque Values

| FASTENER   | TORQUE VALUE          |               | NOTES  |
|--|-----------------------|---------------|--|
| ET sensor  | 11-16 ft-lbs          | 14.9-21.2 N-m | 8.50 ENGINE TEMPERATURE (ET) SENSOR, Install                                       |
| Engine guard lower screws  | 15-20 ft-lbs          | 20.3-27.1 N-m | 3.33 ENGINE GUARD, Install   |
| Engine guard upper screws  | 22-28 ft-lbs          | 29.8-37.9 N-m | 3.33 ENGINE GUARD, Install   |
| Engine mount, lower front, end cap screws                              | 42-48 ft-lbs          | 56.9-65 N-m   | 4.12 FRONT ENGINE MOUNT, Remove and Install: Lower Front Engine Mount              |
| Engine mount, lower front, flange nut                                  | 50-55 ft-lbs          | 67.8-74.6 N-m | 4.12 FRONT ENGINE MOUNT, Remove and Install: Lower Front Engine Mount              |
| Engine mount, upper front, stabilizer link screws                      | 30.0-35.0 ft-lbs      | 40.7-47.5 N-m | 4.12 FRONT ENGINE MOUNT, Remove and Install: Upper Front Engine Mount              |
| Engine oil drain plug  | 14-21 ft-lbs          | 19-28.5 N-m   | 2.5 REPLACE ENGINE OIL AND FILTER, Change Oil and Oil Filter                       |
| Engine stabilizer bracket screws                                       | 45.0-50.0 ft-lbs      | 61-67.8 N-m   | 4.12 FRONT ENGINE MOUNT, Remove and Install: Upper Front Engine Mount              |
| Enginemount end cap screws, front                                      | 42-48 ft-lbs          | 56.9-65 N-m   | 3.18 BRAKE LINES, Brake Line: Rear Master Cylinder to ABS Module                   |
| Exhaust bracket to transmission, screw                                 | <b>100-120</b> in-lbs | 11.3-13.6 N-m | 6.21 EXHAUST SYSTEM, Install   |
| Exhaust cross-over bracket flange bolt                                 | 14-18 ft-lbs          | 19-24.4 N-m   | 6.21 EXHAUST SYSTEM, Install   |
| Exhaust cross-over pipe clamp  | 38-43 ft-lbs          | 51.5-58.3 N-m | 6.21 EXHAUST SYSTEM, Install   |
| Exhaust flange nut, 1st torque   | 9-18 in-lbs           | 1-2 N-m       | 6.21 EXHAUST SYSTEM, Install<br>See procedure for appropriate tightening sequence. |
| Exhaust flange nut, final torque                                       | <b>100-120</b> in-lbs | 11.3-13.6 N-m | 6.21 EXHAUST SYSTEM, Install<br>See procedure for appropriate tightening sequence. |
| Exhaust header bracket flange locknut                                  | 15-20 ft-lbs          | 20.3-27.1 N-m | 6.21 EXHAUST SYSTEM, Install   |
| Exhaust shield clamps  | 20-40 in-lbs          | 2.3-4.5 N-m   | 6.21 EXHAUST SYSTEM, Install   |
| Fairing air deflector screws fork-mounted fairing                      | 15-25 in-lbs          | 1.7-2.8 N-m   | 3.34 AIR DEFLECTORS, Remove and Install: Fork Mounted Fairing                      |
| Fairing air deflector screws frame-mounted fairing                     | 8-15 in-lbs           | 0.9-1.7 N-m   | 3.34 AIR DEFLECTORS, Remove and Install: Frame Mounted Fairing                     |
| Fairing air deflector screws: Frame-mounted fairing                    | 8-15 in-lbs           | 0.9-1.7 N-m   | 3.31 FAIRING: FRAME MOUNTED, Remove and Install: Storage Compartments              |
| Fairing gauge screw  | 8-15 in-lbs           | 0.9-1.7 N-m   | 3.31 FAIRING: FRAME MOUNTED, Disassemble and Assemble: Inner Fairing Shell         |
| Fairing lower inner panel screws                                       | 65-75 in-lbs          | 7.3-8.5 N-m   | 3.32 FAIRING LOWERES, Disassemble and Assemble: Air-Cooled                         |
| Fairing mount to steering head locknuts: Frame-mounted fairing         | 20-30 ft-lbs          | 27.1-40.7 N-m | 3.31 FAIRING: FRAME MOUNTED, Remove and Install: Mounting Bracket                  |
| Fairing speaker enclosure to fairing screws                            | 48-60 in-lbs          | 5.4-6.8 N-m   | 3.30 FAIRING: FORK MOUNTED, Remove and Install: Fairing                            |
| Fairing speaker enclosure to fairing support screws                    | 48-60 in-lbs          | 5.4-6.8 N-m   | 8.33 FRONT SPEAKERS, Remove and Install: Fork Mounted Fairing                      |
| Fairing speaker grille screws  | 9-13 in-lbs           | 1-1.5 N-m     | 3.30 FAIRING: FORK MOUNTED, Remove and Install: Fairing                            |
| Fairing speaker screws   | 9-13 in-lbs           | 1-1.5 N-m     | 8.33 FRONT SPEAKERS, Remove and Install: Fork Mounted Fairing                      |
| Fairing support bracket-to-engine guard screws                         | 40-50 in-lbs          | 4.5-5.7 N-m   | 3.31 FAIRING: FRAME MOUNTED, Remove and Install: Inner Fairing Shell               |
| Fairing support bracket-to-inner fairing screws: Frame-mounted fairing | 48-60 in-lbs          | 5.4-6.8 N-m   | 3.31 FAIRING: FRAME MOUNTED, Remove and Install: Inner Fairing Shell               |
| Fairing vent to inner fairing: fork mounted fairing                    | 20-30 in-lbs          | 2.3-3.4 N-m   | 3.30 FAIRING: FORK MOUNTED, Remove and Install: Vent                               |
| Fascia lamp screw  | 18-22 in-lbs          | 2-2.5 N-m     | 8.28 REAR FENDER TIP LAMP, Remove and Install: Fascia Lamp                         |

## Torque Values

| FASTENER  | TORQUE VALUE   |               | NOTES   |
|---|----------------|---------------|---|
| Fender tip lamp, front  | 20-25 in-lbs   | 2.3-2.8 N-m   | 8.25 FRONT FENDER TIP LAMP, Install                                 |
| Fender trim strips, front   | 10-15 in-lbs   | 1.1-1.7 N-m   | 8.25 FRONT FENDER TIP LAMP, Install                                 |
| Footboard bracket screws, rider   | 36--42 ft-lbs  | 48.8-56.9 N-m | 3.43 RIDER FOOTRESTS, Install                                       |
| Footboard pivot screw nut, rider  | 60-80 in-lbs   | 6.8-9 N-m     | 3.43 RIDER FOOTRESTS, Assemble                                      |
| Footboard/footpeg lower fastener, passenger: FLHX, FLHXS, FLTRX, FLTRXS, FLHRXS | 48-72 in-lbs   | 5.4-8.1 N-m   | 3.44 PASSENGER FOOTRESTS, Install                                   |
| Footboard/footpeg upper fastener, passenger: FLHX, FLHXS, FLTRX, FLTRXS, FLHRXS | 36--42 ft-lbs  | 48.8-56.9 N-m | 3.44 PASSENGER FOOTRESTS, Install                                   |
| Footpeg pad screw: FLHX, FLHXS, FLTRX, FLTRXS, FLHRXS                           | 15-20 ft-lbs   | 20.3-27.1 N-m | 3.44 PASSENGER FOOTRESTS, Install                                   |
| Footpeg pad screw: FLHX,FLHXS, FLTRX, FLHRXS, FLHRXS                            | 15-20 ft-lbs   | 20.3-27.1 N-m | 3.44 PASSENGER FOOTRESTS, Assemble                                  |
| Fork bracket to fork pinch screws   | 14-18 ft-lbs   | 19-24.4 N-m   | 3.23 FRONT FORK, Install  |
| Fork bracket to fork pinch screws   | 14-18 ft-lbs   | 19-24.4 N-m   | 3.24 STEERING HEAD/FORK STEM AND BRACKET ASSEMBLY, Install          |
| Fork bracket to steer stem pinch screw  | 22-26 ft-lbs   | 29.8-35.2 N-m | 3.24 STEERING HEAD/FORK STEM AND BRACKET ASSEMBLY, Install          |
| Fork mounted dash panel screw   | 25-30 in-lbs   | 2.8-3.4 N-m   | 3.30 FAIRING: FORK MOUNTED, Remove and Install: Dash Panel          |
| Fork mounted fairing screw  | 20-30 in-lbs   | 2.3-3.4 N-m   | 3.30 FAIRING: FORK MOUNTED, Remove and Install: Outer Fairing Shell |
| Fork mounted headlamp door screw  | 9-18 in-lbs    | 1-2 N-m       | 3.30 FAIRING: FORK MOUNTED, Remove and Install: Headlamp Assembly   |
| Fork mounted headlamp screw   | 22-32 in-lbs   | 2.5-3.6 N-m   | 3.30 FAIRING: FORK MOUNTED, Remove and Install: Headlamp Assembly   |
| Fork mounted inner fairing double stud  | 120-180 in-lbs | 13.6-20.3 N-m | 3.30 FAIRING: FORK MOUNTED, Detach Fairing For Service              |
| Fork mounted windshield screw   | 25-30 in-lbs   | 2.8-3.4 N-m   | 3.30 FAIRING: FORK MOUNTED, Remove and Install: Outer Fairing Shell |
| Fork slider assembly screw  | 30-37 ft-lbs   | 40-50 N-m     | 3.23 FRONT FORK, Assemble   |
| Fork slider cover screws  | 24--48 in-lbs  | 2.7-5.4 N-m   | 3.23 FRONT FORK, Install  |
| Fork-mounted mirror flange nut  | 20-30 in-lbs   | 2.3-3.4 N-m   | 3.38 MIRRORS, Remove and Install: Fairing Mount                     |
| Front axle nut  | 70-75 ft-lbs   | 95-102 N-m    | 3.4 FRONT WHEEL, Install  |
| Front axle pinch screw  | 18-22 ft-lbs   | 24.5-30 N-m   | 3.4 FRONT WHEEL, Install  |
| Front caliper banjo bolt  | 17-19 ft-lbs   | 23-26 N-m     | 3.14 FRONT BRAKE CALIPER, Complete                                  |
| Front caliper mounting screw  | 28-38 ft-lbs   | 38-51.5 N-m   | 3.14 FRONT BRAKE CALIPER, Install                                   |
| Front fender mounting screw   | 16-20 ft-lbs   | 21.7-27.1 N-m | 3.39 FRONT FENDER, Install  |
| Front fender tip screw  | 20-25 in-lbs   | 2.3-2.8 N-m   | 3.39 FRONT FENDER, Assemble   |
| Front fender trim nut   | 10-15 in-lbs   | 1.1-1.7 N-m   | 3.39 FRONT FENDER, Assemble   |
| Front fender trim skirt nut   | 10-15 in-lbs   | 1.1-1.7 N-m   | 3.39 FRONT FENDER, Assemble   |
| Front master cylinder banjo bolt  | 17-19 ft-lbs   | 23.1-25.8 N-m | 3.13 FRONT BRAKE MASTER CYLINDER, Install                           |
| Front master cylinder clamp screw   | 60-80 in-lbs   | 6.8-9 N-m     | 3.13 FRONT BRAKE MASTER CYLINDER, Install                           |
| Front turn signal mounting screw: bullet style                                  | 96-120 in-lbs  | 10.9-13.6 N-m | 8.23 AUXILIARY LAMPS, Install                                       |
| Fuel rail screw   | 30-50 in-lbs   | 3.5-5.5 N-m   | 6.16 FUEL INJECTORS, Install  |
| Fuel tank front screws  | 15-20 ft-lbs   | 20.3-27.1 N-m | 6.8 FUEL TANK, Install  |
| Fuel tank rear bracket screws   | 15-20 ft-lbs   | 20.3-27.1 N-m | 6.8 FUEL TANK, Install  |
| Gauges, 2-inch diameter gauge screws  | 8-15 in-lbs    | 0.9-1.7 N-m   | 3.30 FAIRING: FORK MOUNTED, Remove and Install: Fairing             |
| Gauges, instrument cluster screws   | 10-20 in-lbs   | 1.1-2.3 N-m   | 3.30 FAIRING: FORK MOUNTED, Remove and Install: Fairing             |

## Torque Values

| FASTENER   | TORQUE VALUE        |               | NOTES  |
|--|---------------------|---------------|--|
|  |                     |               |  |
| Glove box screws, lower fairing                      | 12-16 in-lbs        | 1.4—1.8 N-m   | 8.47 COOLING FAN, Complete   |
| Glovebox screw                                       | 60-84 in-lbs        | 6.8-9.5 N-m   | 3.30 FAIRING: FORK MOUNTED, Remove and Install: Glovebox               |
| Ground plate/marker lamp screws                      | 20-25 in-lbs        | 2.3-2.8 N-m   | 8.29 TOUR-PAK LIGHTING, Remove and Install: Side Lamps/Trim Strips     |
| Handlebar clamp shroud screw                         | <b>10-20</b> in-lbs | 1.1-2.3 N-m   | 3.29 HEADLAMP NACELLE, Install   |
| Handlebar upper clamp screws                         | 16-20 ft-lbs        | 21.7-27.1 N-m | 3.37 HANDLEBAR, Adjust   |
| Handlebar upper clamp screws                         | 16-20 ft-lbs        | 21.7-27.1 N-m | 3.37 HANDLEBAR, Remove and Install: Without Fairing                    |
| Harness ground stud flange nut                       | 50-90 in-lbs        | 5.7-10.2 N-m  | 8.65 MAIN WIRE HARNESS, Remove and Install: Common Components          |
| Harness ground stud flange nut                       | 50-90 in-lbs        | 5.7-10.2 N-m  | 8.11 IGNITION COIL, Install  |
| Headlamp bezel: Dual headlamp                        | 8-15 in-lbs         | 0.9-1.7 N-m   | 8.22 HEADLAMP, Remove and Install: Dual Headlamp                       |
| Headlamp door screw                                  | 9-18 in-lbs         | 1-2 N-m       | 3.29 HEADLAMP NACELLE, Install   |
| Headlamp mount to nacelle screw                      | 9-18 in-lbs         | 1-2 N-m       | 3.29 HEADLAMP NACELLE, Install   |
| Headlamp nacelle acorn nut FLHR/C                    | 96-132 in-lbs       | 10.8-14.9 N-m | 3.29 HEADLAMP NACELLE, Install   |
| Headlamp nacelle chrome strip flange nut             | 15-20 in-lbs        | 1.7-2.3 N-m   | 3.29 HEADLAMP NACELLE, Install   |
| Headlamp nacelle stud/nut/grommet assembly FLHR/C    | 96-132 in-lbs       | 10.8-14.9 N-m | 3.29 HEADLAMP NACELLE, Install   |
| Headlamp retaining ring screws: Single headlamp      | 23-26 in-lbs        | 2.6-2.9 N-m   | 8.22 HEADLAMP, Remove and Install: Single Headlamp                     |
| Headlamp screws: Dual headlamp                       | 48-60 in-lbs        | 5.4-6.8 N-m   | 8.22 HEADLAMP, Remove and Install: Dual Headlamp                       |
| Horn bracket acorn nut                               | 80-120 in-lbs       | 9-13.6 N-m    | 8.21 HORN, Install   |
| Horn bracket to cylinder head screws                 | 35-40 ft-lbs        | 47.5-54.2 N-m | 8.21 HORN, Install   |
| Horn cover to bracket                                | 35-40 in-lbs        | 3.9-4.5 N-m   | 8.21 HORN, Assemble  |
| Horn rubber mount                                    | 120-180 in-lbs      | 13.6-20.3 N-m | 8.21 HORN, Install   |
| Horn stud flange nut                                 | 80-100 in-lbs       | 9-11.3 N-m    | 8.21 HORN, Assemble  |
| Hydraulic line multi-clamp screw                     | 10-15 in-lbs        | 1.1-1.7 N-m   | 3.18 BRAKE LINES, Brake Line: Rear Master Cylinder to ABS Module       |
| IM screw: Fork-mounted fairing                       | <b>10-20</b> in-lbs | 1.1-2.3 N-m   | 8.15 INSTRUMENT MODULE (IM), Install                                   |
| IM screw: Frame-mounted fairing                      | 12-17 in-lbs        | 1.4-1.9 N-m   | 8.15 INSTRUMENT MODULE (IM), Install                                   |
| IMU screw  | 32-40 in-lbs        | 3.6-4.5 N-m   | 8.55 INERTIAL MEASUREMENT UNIT (IMU), Install                          |
| Ignition coil screws                                 | 32-40 in-lbs        | 3.6-4.5 N-m   | 8.11 IGNITION COIL, Install  |
| Ignition switch housing screws: Fairing models       | 85-115 in-lbs       | 9.6-13 N-m    | 8.9 IGNITION SWITCH, Remove and Install: Fairing Models                |
| Ignition switch screws: Road King                    | 25-35 in-lbs        | 2.8-3.9 N-m   | 8.9 IGNITION SWITCH, Remove and Install: Non-Fairing Models            |
| Induction module flange adapter screws.              | 96-156 in-lbs       | 10.9-17.6 N-m | 6.17 INDUCTION MODULE, Install   |
| Induction module screw                               | 66-84 in-lbs        | 7.5-9.5 N-m   | 6.17 INDUCTION MODULE, Assemble  |
| Inner fairing to fork bracket studs                  | 120-180 in-lbs      | 13.6-20.3 N-m | 8.64 FAIRING WIRE HARNESS, Remove and Install: Fork Mounted Fairing    |
| Inner fairing to mount screws: frame-mounted fairing | 96-144 in-lbs       | 10.9-16.3 N-m | 3.31 FAIRING: FRAME MOUNTED, Remove and Install: Radio Support Bracket |
| Inner fairing-to-mount screws: Frame-mounted fairing | 96 in-lbs           | 10.9 N-m      | 3.31 FAIRING: FRAME MOUNTED, Remove and Install: Inner Fairing Shell   |
| Instrument bezel screws                              | 10-15 in-lbs        | 1.1-1.7 N-m   | 3.31 FAIRING: FRAME MOUNTED, Remove and Install: Instrument Bezel      |
| Instrument nacelle to fork bracket screws            | 96 in-lbs           | 10.8 N-m      | 3.31 FAIRING: FRAME MOUNTED, Remove and Install: Instrument Nacelle    |
| Jiffy stand bracket fasteners                        | 36-42 ft-lbs        | 48.8-57 N-m   | 3.45 JIFFY STAND, Install  |
| Jiffy stand leg stop hex screw                       | 15-20 ft-lbs        | 20.3-27.1 N-m | 3.45 JIFFY STAND, Install  |

## Torque Values

| FASTENER   | TORQUE VALUE   |               | NOTES  |
|--|----------------|---------------|--|
| Jiffy stand sensor screw                           | 96-120 in-lbs  | 10.8-13.6 N-m | 8.56 JIFFY STAND SENSOR (JSS), Install                                     |
| Knock sensor screw                                 | 13-17 ft-lbs   | 17.6-23 N-m   | 8.51 KNOCK SENSOR (KS), Install  |
| LHCM housing screw.                                | 35-44 in-lbs   | 4-5 N-m       | 8.12 LEFT HAND CONTROL MODULE (LHCM), Install                              |
| Left caddy screws                                  | 72-96 in-lbs   | 8.1-10.9 N-m  | 8.59 LEFT SIDE CADDY, Install  |
| License plate bracket screws                       | 60-80 in-lbs   | 6.8-9 N-m     | 8.26 REAR TURN SIGNAL LAMPS, Remove and Install: Bullet Style              |
| Lifter anti-rotation device screw                  | 90-120 in-lbs  | 10.2-13.6 N-m | 4.17 PUSHRODS, LIFTERS AND COVERS, Install                                 |
| Lifter cover screws                                | 132-156 in-lbs | 14.9-17.6 N-m | 4.17 PUSHRODS, LIFTERS AND COVERS, Install                                 |
| Lower air vent halves                              | 9-13 in-lbs    | 1-1.5 N-m     | 3.31 FAIRING: FRAME MOUNTED, Remove and Install: Lower Vents               |
| Lower air vent to inner fairing                    | 8-15 in-lbs    | 0.9-1.7 N-m   | 3.31 FAIRING: FRAME MOUNTED, Remove and Install: Lower Vents               |
| Lower fairing cap flange nut                       | 30-35 in-lbs   | 3.4-3.9 N-m   | 3.32 FAIRING LOWERES, Remove and Install: Air-Cooled                       |
| Lower fairing glove box screws                     | 12-17 in-lbs   | 1.4-1.9 N-m   | 3.32 FAIRING LOWERES, Disassemble and Assemble: Air-Cooled                 |
| Lower fairing glove box tray screws                | 12-18 in-lbs   | 1.4-2 N-m     | 3.32 FAIRING LOWERES, Disassemble and Assemble: Air-Cooled                 |
| Lower fairing vent knob screw                      | 12-18 in-lbs   | 1.4-2 N-m     | 3.32 FAIRING LOWERES, Disassemble and Assemble: Air-Cooled                 |
| Lower fairing, lower clamp                         | 90-100 in-lbs  | 10.2-11.3 N-m | 3.32 FAIRING LOWERES, Remove and Install: Air-Cooled                       |
| Lower fairing, upper clamp nuts                    | 30-35 in-lbs   | 3.4-3.9 N-m   | 3.32 FAIRING LOWERES, Remove and Install: Air-Cooled                       |
| Lower screw (7)                                    | 48-72 in-lbs   | 5.4-8.1 N-m   | 3.44 PASSENGER FOOTRESTS, Install  |
| Lower vent to inner fairing: frame-mounted fairing | 8-15 in-lbs    | 0.9-1.7 N-m   | 3.31 FAIRING: FRAME MOUNTED, Disassemble and Assemble: Inner Fairing Shell |
| Master cylinder banjo bolt                         | 17-19 ft-lbs   | 23.1-25.8 N-m | 3.18 BRAKE LINES, Brake Line: Front Master Cylinder to ABS Module          |
| Master cylinder screws                             | 126-150 in-lbs | 14.2-17 N-m   | 3.15 REAR BRAKE MASTER CYLINDER, Install                                   |
| Media compartment screw, lower                     | 8-12 in-lbs    | 0.9-1.3 N-m   | 3.30 FAIRING: FORK MOUNTED, Remove and Install: Fairing                    |
| Media compartment screw, upper                     | 25-35 in-lbs   | 2.8-4 N-m     | 3.30 FAIRING: FORK MOUNTED, Remove and Install: Upper Support Bracket      |
| Mid-Frame deflector screw                          | 25-35 in-lbs   | 2.8-4 N-m     | 3.34 AIR DEFLECTORS, Remove and Install: Mid Frame Deflectors              |
| Mirror stem acorn nut                              | 120-144 in-lbs | 13.6-16.3 N-m | 3.38 MIRRORS, Remove and Install: Handlebar Mount                          |
| Muffler to clamp                                   | 38-43 ft-lbs   | 51.5-58.3 N-m | 6.20 MUFFLERS, Install   |
| Muffler to saddlebag support screws                | 14-18 ft-lbs   | 19-24.4 N-m   | 2.18 INSPECT AND ADJUST DRIVE BELT AND SPROCKETS, Adjust Belt              |
| Nacelle switch hex nut                             | 9-15 in-lbs    | 1-1.7 N-m     | 8.14 ACCESSORY SWITCHES, Remove and Install: Nacelle Mounted               |
| Negative battery cable screw                       | 60-70 in-lbs   | 6.8-7.9 N-m   | 8.4 POWER DISCONNECT, Negative Battery Cable                               |
| Oil cooler screws                                  | 96-120 in-lbs  | 10.8-13.6 N-m | 4.9 OIL COOLER, Assemble   |
| Oil line manifold screws                           | 90-120 in-lbs  | 10.2-13.6 N-m | 4.11 OIL COOLANT LINES, Install  |
| Oil pan fasteners                                  | 132-156 in-lbs | 14.9-17.6 N-m | 4.26 OIL PAN, Install  |
| Oil pan tapered plug                               | 30-36 ft-lbs   | 40.7-48.8 N-m | 4.26 OIL PAN, Install  |
| Oil pump screws, 1st torque                        | 12-60 in-lbs   | 1.4-6.8 N-m   | 4.21 CAM COMPARTMENT AND COMPONENTS, Install                               |

## Torque Values

| FASTENER   | TORQUE VALUE          |               | NOTES   |
|--|-----------------------|---------------|---|
| Oil pump screws, final torque  | 90-120 in-lbs         | 10.2-13.6 N-m | 4.21 CAM COMPARTMENT AND COMPONENTS, Install  |
| Oil return tube screw  | <b>100-120</b> in-lbs | 11.3-13.6 N-m | 5.15 TRANSMISSION CASE, Assemble  |
| Outer fairing lower screws (also air deflector): frame mounted fairing | 8-15 in-lbs           | 0.9-1.7 N-m   | 3.31 FAIRING: FRAME MOUNTED, Remove and Install: Outer Fairing Shell                      |
| Outer fairing screws: Fork-mounted fairing models                      | 20-30 in-lbs          | 2.3-3.4 N-m   | 3.30 FAIRING: FORK MOUNTED, Remove and Install: Windshield                                |
| Outer fairing upper screws (near speakers): frame mounted fairing      | 20-30 in-lbs          | 2.3-3.4 N-m   | 3.31 FAIRING: FRAME MOUNTED, Remove and Install: Outer Fairing Shell                      |
| Oxygen sensor, heated  | 12-14 ft-lbs          | 16-19 N-m     | 6.19 HEATED OXYGEN SENSORS (HO2S), Install<br>add anti-seize lubricant (98960-97)         |
| Parking brake nut  | 10-14 ft-lbs          | 14-19 N-m     | 3.17 PARKING BRAKE ASSEMBLY, Install  |
| Passenger audio switch screws  | 25-30 in-lbs          | 2.8-3.4 N-m   | 8.34 REAR SPEAKERS, Assemble  |
| Passenger backrest flange nuts.  | 108-132 in-lbs        | 12.2-14.9 N-m | 3.48 TOUR-PAK, Install  |
| Passenger backrest flap screws   | 21-24 in-lbs          | 2.4-2.7 N-m   | 3.48 TOUR-PAK, Install  |
| Passenger headset connector nut  | 7-9 in-lbs            | 0.8-1 N-m     | 8.34 REAR SPEAKERS, Assemble  |
| Piston jet screws  | 25-35 in-lbs          | 2.8-3.9 N-m   | 4.24 CRANKCASE, Repair Right Crankcase Half   |
| Power outlet, front  | 13-17 in-lbs          | 1.5-1.9 N-m   | 3.30 FAIRING: FORK MOUNTED, Remove and Install: Fairing                                   |
| Primary chain tensioner fasteners                                      | 21-24 ft-lbs          | 28.5-32.6 N-m | 5.9 DRIVE COMPONENTS, Install   |
| Primary chaincase drain plug   | 14-21 ft-lbs          | 19-28.5 N-m   | 2.6 REPLACE PRIMARY CHAINCASE LUBRICANT, Change Primary Chaincase Lubricant               |
| Primary chaincase sealing screws                                       | 26-28 ft-lbs          | 35.3-38 N-m   | 5.11 PRIMARY CHAINCASE HOUSING, Install   |
| Primary cover screws   | 144-156 in-lbs        | 16.3-17.6 N-m | 5.8 PRIMARY CHAINCASE COVER, Install<br>See sequence in the procedure                     |
| RHCM housing screw   | <b>35-44</b> in-lbs   | 4-5 N-m       | 8.13 RIGHT HAND CONTROL MODULE (RHCM), Install  |
| Radio antenna base inner set screw                                     | 14-16 in-lbs          | 1.6-1.8 N-m   | 8.29 TOUR-PAK LIGHTING, Remove and Install: Wrap-Around Lamp                              |
| Radio support bracket to inner fairing screws: frame-mounted fairing   | 48-60 in-lbs          | 5.4-6.8 N-m   | 3.31 FAIRING: FRAME MOUNTED, Disassemble and Assemble: Inner Fairing Shell                |
| Radio to fairing support bracket screws                                | 60-84 in-lbs          | 6.8-9.5 N-m   | 8.32 RADIO, Remove and Install: Frame Mounted Fairing                                     |
| Radio upper bracket: FLTR  | 25-35 in-lbs          | 2.8-4 N-m     | 8.32 RADIO, Remove and Install: Frame Mounted Fairing                                     |
| Radio-to-upper support bracket screw                                   | 60-84 in-lbs          | 6.8-9.5 N-m   | 8.32 RADIO, Remove and Install: Fork Mounted Fairing                                      |
| Rear axle cone nut, 1st torque   | 15-20 ft-lbs          | 20-27 N-m     | 2.18 INSPECT AND ADJUST DRIVE BELT AND SPROCKETS, Adjust Belt<br>For belt adjustment only |
| Rear axle cone nut, final torque                                       | 135-145 ft-lbs        | 183-196.6 N-m | 2.18 INSPECT AND ADJUST DRIVE BELT AND SPROCKETS, Adjust Belt                             |
| Rear battery tray screw  | 132-156 in-lbs        | 14.9-17.6 N-m | 3.18 BRAKE LINES, Brake Line: Front Master Cylinder to ABS Module                         |
| Rear caliper banjo bolt  | 17-19 ft-lbs          | 23.1-25.8 N-m | 3.16 REAR BRAKE CALIPER, Complete   |
| Rear caliper mounting screw  | 43-48 ft-lbs          | 58.3-65.1 N-m | 3.16 REAR BRAKE CALIPER, Install  |
| Rear fender mounting nut   | 15-20 ft-lbs          | 20.3-27.1 N-m | 3.40 REAR FENDER, Assemble  |
| Rear fender mounting screw   | 15-20 ft-lbs          | 20.3-27 N-m   | 3.40 REAR FENDER, Install   |
| Rear fender stud plate nut   | 60-96 in-lbs          | 6.8-10.8 N-m  | 3.40 REAR FENDER, Assemble  |

## Torque Values

| FASTENER  | TORQUE VALUE    |               | NOTES  |
|---|-----------------|---------------|--|
| Rear fork bracket screws                                    | 55-65 ft-lbs    | 74.6-88.1 N-m | 3.25 REAR FORK, Install  |
| Rear fork pivot shaft screws                                | 55-65 ft-lbs    | 74.6-88.1 N-m | 3.25 REAR FORK, Install  |
| Rear frame to main frame fastener                           | 40-45 ft-lbs    | 54.2-61 N-m   | 3.47 REAR FRAME, Install   |
| Rear lightbar screw   | 84-120 in-lbs   | 9.5-13.6 N-m  | 8.26 REAR TURN SIGNAL LAMPS, Remove and Install: Flat Lens Style |
| Rear master cylinder banjo bolt                             | 17-19 ft-lbs    | 23-25.8 N-m   | 3.15 REAR BRAKE MASTER CYLINDER, Install                         |
| Rear rotor screw  | 30-45 ft-lbs    | 41-61 N-m     | 3.5 REAR WHEEL, Assemble   |
| Rear shock absorber mounting bolt                           | 63-70 ft-lbs    | 85.4-95 N-m   | 3.27 REAR SHOCK ABSORBERS, Install                               |
| Rear speaker enclosure to Tour-Pak screws                   | 20-25 in-lbs    | 2.3-2.8 N-m   | 8.34 REAR SPEAKERS, Install                                      |
| Rear stop lamp switch                                       | 144 in-lbs      | 16.3 N-m      | 8.30 REAR STOPLAMP SWITCH, Install                               |
| Rear turn signal to lightbar screw                          | 30-50 in-lbs    | 3.4-5.6 N-m   | 8.26 REAR TURN SIGNAL LAMPS, Remove and Install: Flat Lens Style |
| Rider headset connector nut                                 | 7-9 in-lbs      | 0.8-1 N-m     | 8.36 RIDER HEADSET CONNECTOR, Install                            |
| Right caddy to battery tray screw                           | 36-40 in-lbs    | 4.1-4.5 N-m   | 8.60 RIGHT SIDE CADDY, Install                                   |
| Rocker cover, lower, screws                                 | 90-120 in-lbs   | 10.2-13.6 N-m | 4.15 LOWER ROCKER COVERS, Install                                |
| Rocker cover, lower, stud                                   | 90-120 in-lbs   | 10.2-13.6 N-m | 4.13 UPPER ROCKER COVERS, Install                                |
| Rocker cover, upper, screws                                 | 120-140 in-lbs  | 13.6-15.8 N-m | 4.13 UPPER ROCKER COVERS, Install                                |
| Rocker shaft screw  | 23-27 ft-lbs    | 31.2-36.6 N-m | 4.16 ROCKER ARMS, Install  |
| Saddlebag face plate/hinge screw                            | 40-45 in-lbs    | 4.5-5.1 N-m   | 3.50 SADDLEBAGS, Assemble  |
| Saddlebag face plate/hinge screws                           | 40-45 in-lbs    | 4.5-5.1 N-m   | 3.50 SADDLEBAGS, Assemble  |
| Saddlebag guard to frame screw, lower                       | 32-36 ft-lbs    | 43.4-48.8 N-m | 3.51 SADDLEBAG SUPPORTS, Install                                 |
| Saddlebag guard to frame screw, upper                       | 32-36 ft-lbs    | 43.4-48.8 N-m | 3.51 SADDLEBAG SUPPORTS, Install                                 |
| Saddlebag hinge to latch assembly screws                    | 30-35 in-lbs    | 3.4-3.9 N-m   | 3.50 SADDLEBAGS, Assemble  |
| Saddlebag hinge to saddlebag screws                         | 40-45 in-lbs    | 4.5-5.1 N-m   | 3.50 SADDLEBAGS, Assemble  |
| Saddlebag latch assembly screws                             | 40-45 in-lbs    | 4.5-5.1 N-m   | 3.50 SADDLEBAGS, Assemble  |
| Saddlebag latch handle screw                                | 40-45 in-lbs    | 4.5-5.1 N-m   | 3.50 SADDLEBAGS, Assemble  |
| Saddlebag lock lever nut                                    | 25-35 in-lbs    | 2.8-3.9 N-m   | 3.50 SADDLEBAGS, Assemble  |
| Saddlebag lock screw  | 20-30 in-lbs    | 2.3-3.4 N-m   | 3.50 SADDLEBAGS, Assemble  |
| Saddlebag strike screw                                      | 15-20 in-lbs    | 1.7-2.3 N-m   | 3.50 SADDLEBAGS, Assemble  |
| Saddlebag support casting to frame screw                    | 15-20 ft-lbs    | 20.3-27.1 N-m | 3.51 SADDLEBAG SUPPORTS, Install                                 |
| Saddlebag support tube screw                                | 70-100 in-lbs   | 7.9-11.3 N-m  | 3.51 SADDLEBAG SUPPORTS, Install                                 |
| Saddlebag support tube to support casting fastener, large   | 30-37 ft-lbs    | 40.7-50.2 N-m | 3.51 SADDLEBAG SUPPORTS, Install                                 |
| Saddlebag support tube to support casting fastener, small   | 15-20 ft-lbs    | 20.3-27.1 N-m | 3.51 SADDLEBAG SUPPORTS, Install                                 |
| Saddlebag tether screws                                     | 40-45 in-lbs    | 4.5-5.1 N-m   | 3.50 SADDLEBAGS, Assemble  |
| Seat bumper fastener: FLHX, FLHXS and FLTRX, FLTRXS, FLHRXS | 32-36 ft-lbs    | 43.4-48.8 N-m | 3.46 SEAT, Install   |
| Seat mounting screw   | 48-72 in-lbs    | 5.4-8.1 N-m   | 3.46 SEAT, Install   |
| Seat strap bracket screw                                    | 120-144 in-lbs  | 13.6-16.3 N-m | 3.51 SADDLEBAG SUPPORTS, Install                                 |
| Seat strap screw  | 48-72 in-lbs    | 5.4-8.1 N-m   | 3.46 SEAT, Install   |
| Shift drum detent screw                                     | 120-150 in-lbs  | 13.6-17 N-m   | 5.13 TRANSMISSION, Assemble                                      |
| Shift drum lock plate screws                                | 57-63 in-lbs    | 6.4-7.1 N-m   | 5.13 TRANSMISSION, Assemble                                      |
| Shift lever pinch screw                                     | 9.0-12.0 ft-lbs | 12.2-16.3 N-m | 5.5 SHIFTER LINKAGE, Foot Shift Lever                            |
| Shifter pawl centering screw                                | 18-23 ft-lbs    | 24.4-31.2 N-m | 5.15 TRANSMISSION CASE, Assemble                                 |
| Shifter peg screw   | 96-144 in-lbs   | 10.9-16.3 N-m | 5.5 SHIFTER LINKAGE, Foot Shift Lever                            |
| Shifter rod jamnut  | 80-120 in-lbs   | 9-13.6 N-m    | 5.5 SHIFTER LINKAGE, Shifter Rod                                 |
| Shifter rod lever pinch screw                               | 18-22 ft-lbs    | 24.4-29.8 N-m | 5.15 TRANSMISSION CASE, Assemble                                 |
| Shifter rod lever pinch screw, front lever                  | 132-156 in-lbs  | 14.9-17.6 N-m | 5.5 SHIFTER LINKAGE, Shifter Rod Lever, Front                    |
| Shifter rod nut   | 8-12 ft-lbs     | 11-16 N-m     | 5.5 SHIFTER LINKAGE, Shifter Rod                                 |

## Torque Values

| FASTENER                                       | TORQUE VALUE     |               | NOTES  |
|--|------------------|---------------|--|
| Shock absorber mounting bolt                   | 63-70 ft-lbs     | 85.4-95 N-m   | 3.25 REAR FORK, Complete   |
| Spark plug                                     | 89-133 in-lbs    | 10-15 N-m     | 2.24 CLEAN AND INSPECT SPARK PLUGS, Install  |
| Speaker enclosure mounting screws, front, FLTR | 48-60 in-lbs     | 5.4-6.8 N-m   | 8.33 FRONT SPEAKERS, Remove and Install: Frame Mounted Fairing   |
| Speaker mounting screws                        | 9-13 in-lbs      | 1-1.5 N-m     | 8.33 FRONT SPEAKERS, Remove and Install: Frame Mounted Fairing   |
| Speedometer bracket acorn nuts: FLHP           | 72-108 in-lbs    | 8.1-12.2 N-m  | 3.29 HEADLAMP NACELLE, Complete  |
| Spoke nipple                                   | 55 in-lbs        | 6.2 N-m       | 2.8 INSPECT TIRES AND WHEELS, Wheel Spokes   |
| Starter mounting screw                         | 22-24 ft-lbs     | 29.8-32.5 N-m | 8.6 STARTER, Install<br>Apply a light coat of LOCTITE 243 MEDIUM STRENGTH THREADLOCKER AND SEALANT (BLUE) (99642-97) |
| Starter solenoid stud nut                      | 70-104 in-lbs    | 7.9-11.8 N-m  | 8.6 STARTER, Install   |
| Stator mounting screws                         | 55-75 in-lbs     | 6.2-8.5 N-m   | 8.7 ALTERNATOR, Install<br>Always use new screws   |
| Storage compartment door hinge screws          | 8-15 in-lbs      | 0.9-1.7 N-m   | 3.31 FAIRING: FRAME MOUNTED, Remove and Install: Storage Compartment Doors and Hinges                                |
| Storage compartment door screws                | 8-15 in-lbs      | 0.9-1.7 N-m   | 3.31 FAIRING: FRAME MOUNTED, Remove and Install: Storage Compartment Doors and Hinges                                |
| Storage compartment screws                     | 48-60 in-lbs     | 5.4-6.8 N-m   | 3.31 FAIRING: FRAME MOUNTED, Disassemble and Assemble: Inner Fairing Shell   |
| Switch, Neutral Indicator                      | 120-180 in-lbs   | 13.6-20.3 N-m | 8.20 NEUTRAL INDICATOR SWITCH, Install   |
| Switch, Oil Pressure                           | 13-17 ft-lbs     | 17-23 N-m     | 8.19 OIL PRESSURE SWITCH, Install  |
| Tail lamp base screw                           | 40-48 in-lbs     | 4.5-5.4 N-m   | 8.27 TAIL LAMP, Install  |
| Tail lamp screws                               | 20-24 in-lbs     | 2.3-2.7 N-m   | 8.27 TAIL LAMP, Bulb Replacement   |
| Temperature sensor, radiator                   | 17.7-19.2 ft-lbs | 24-26 N-m     | 7.9 ENGINE COOLANT TEMPERATURE (ECT) SENSOR, Install   |
| Throttle body to manifold screws               | 35-53 in-lbs     | 4-6 N-m       | 6.17 INDUCTION MODULE, Assemble  |
| Top caddy screws                               | 72-96 in-lbs     | 8.1-10.9 N-m  | 8.58 TOP CADDY, Install  |
| Top vent door mechanism screws                 | 6-8 in-lbs       | 0.7-0.9 N-m   | 3.31 FAIRING: FRAME MOUNTED, Remove and Install: Upper Vent  |
| Tour-Pak adapter mounting screws               | 60-72 in-lbs     | 6.8-8.1 N-m   | 3.48 TOUR-PAK, Install   |
| Tour-Pak catch screws                          | 25-35 in-lbs     | 2.8-3.9 N-m   | 3.48 TOUR-PAK, Disassemble and Assemble  |
| Tour-Pak ground plate screw                    | 20-25 in-lbs     | 2.3-2.8 N-m   | 8.63 TOUR-PAK WIRE HARNESS, Install  |
| Tour-Pak hinge screw                           | 25-35 in-lbs     | 2.8-3.9 N-m   | 3.48 TOUR-PAK, Disassemble and Assemble  |
| Tour-Pak latch handle screws                   | 25-35 in-lbs     | 2.8-3.9 N-m   | 3.48 TOUR-PAK, Disassemble and Assemble  |
| Tour-Pak lockset screws                        | 25-35 in-lbs     | 2.8-3.9 N-m   | 3.48 TOUR-PAK, Disassemble and Assemble  |
| Tour-Pak luggage rack fastener                 | 40-48 in-lbs     | 4.5-5.4 N-m   | 3.48 TOUR-PAK, Disassemble and Assemble  |
| Tour-Pak mounting nuts                         | 60-72 in-lbs     | 6.8-8.1 N-m   | 3.48 TOUR-PAK, Install   |
| Tour-Pak side marker lamp screws               | 20-25 in-lbs     | 2.3-2.8 N-m   | 3.48 TOUR-PAK, Disassemble and Assemble  |
| Tour-Pak support cover screws                  | 8-18 in-lbs      | 0.9-2 N-m     | 3.49 TOUR-PAK SUPPORT, Assemble  |
| Tour-Pak support screws                        | 15-20 ft-lbs     | 20.3-27.1 N-m | 3.49 TOUR-PAK SUPPORT, Install   |
| Tour-Pak tether anchor screws                  | 16-22 in-lbs     | 1.8-2.5 N-m   | 3.48 TOUR-PAK, Disassemble and Assemble  |





## Torque Values

| FASTENER   | TORQUE VALUE   |                 | NOTES   |
|--|----------------|-----------------|---|
| Tour-Pak tether reel screws  | 16-22 in-lbs   | 1.8-2.5 N-m     | 3.48 TOUR-PAK, Disassemble and Assemble   |
| Transmission bearing housing screw   | 22-25 ft-lbs   | 29.8-33.9 N-m   | 5.13 TRANSMISSION, Install  |
| Transmission drain plug  | 14-21 ft-lbs   | 19-28.5 N-m     | 2.7 REPLACE TRANSMISSION LUBRICANT, Change Transmission Lubricant   |
| Transmission filler plug/dipstick  | 25-75 in-lbs   | 2.8-8.5 N-m     | 2.7 REPLACE TRANSMISSION LUBRICANT, Check Transmission Lubricant  |
| Transmission mainshaft/countershaft locknuts   | 85-95 ft-lbs   | 115.3-128.8 N-m | 5.13 TRANSMISSION, Assemble   |
| Transmission mounting bolts, 1st torque  | 15 ft-lbs      | 20.3 N-m        | 5.15 TRANSMISSION CASE, Install   |
| Transmission mounting bolts, final torque  | 34-39 ft-lbs   | 46.1-52.9 N-m   | 5.15 TRANSMISSION CASE, Install   |
| Transmission sprocket lockplate screws   | 90-120 in-lbs  | 10.2-13.6 N-m   | 5.12 TRANSMISSION SPROCKET, Install Lock patch, use 3-5 times   |
| Transmission sprocket nut, 1st torque  | 100 ft-lbs     | 135.6 N-m       | 5.12 TRANSMISSION SPROCKET, Install   |
| Transmission sprocket nut, 2nd torque  | 35 ft-lbs      | 47.5 N-m        | 5.12 TRANSMISSION SPROCKET, Install plus 35-40 degrees  |
| Transmission sprocket nut, final torque  |                | 35-40°          | 5.12 TRANSMISSION SPROCKET, Install Do not loosen to align lockplate screws.  |
| Transmission top cover screw   | 132-156 in-lbs | 14.9-17.6 N-m   | 5.13 TRANSMISSION, Install  |
| Turn signal lamp mounting screw, front: frame mounted fairing                        | 48-60 in-lbs   | 5.4-6.8 N-m     | 3.31 FAIRING: FRAME MOUNTED, Remove and Install: Outer Fairing Shell  |
| Turn signal lamp to auxiliary/fog lamp bracket screw: Bullet style turn signal lamps | 96-120 in-lbs  | 10.9-13.5 N-m   | 8.22 HEADLAMP, Adjust   |
| Turn signal lamp to auxiliary/fog lamp bracket screws: Flat lens turn signal lamps   | 36-60 in-lbs   | 4.1-6.8 N-m     | 8.22 HEADLAMP, Adjust   |
| Turn signal lamp, front, mounting bracket screws: Flat lens style                    | 36-60 in-lbs   | 4.1-6.8 N-m     | 8.24 FRONT TURN SIGNAL LAMPS, Remove and Install: Light Bar Mount   |
| Turn signal lamps bracket, rear, screws  | 84-144 in-lbs  | 9.5-16.3 N-m    | 8.26 REAR TURN SIGNAL LAMPS, Remove and Install: Bullet Style LOCTITE 262 HIGH STRENGTH THREADLOCKER AND SEALANT (RED) (94759-99) |
| Turn/aux/fog lamp bracket acorn nut, fairing models                                  | 120-180 in-lbs | 13.6-20.3 N-m   | 8.23 AUXILIARY LAMPS, Install   |
| Turn/aux/fog lamp bracket acorn nut, road king models                                | 72-108 in-lbs  | 8.1-12.2 N-m    | 8.23 AUXILIARY LAMPS, Install   |
| Upper screw (2)  | 36-42 ft-lbs   | 48.8-56.9 N-m   | 3.44 PASSENGER FOOTRESTS, Install   |
| Upper steering stem pinch screw  | 22-26 ft-lbs   | 29.8-35.2 N-m   | 2.14 ADJUST AND LUBRICATE STEERING HEAD BEARINGS, Check and Adjust  |
| Upper steering stem, 1st torque  | 35 ft-lbs      | 47.5 N-m        | 3.24 STEERING HEAD/FORK STEM AND BRACKET ASSEMBLY, Install  |
| Upper steering stem, final torque: Fork mounted fairing models                       | 63 in-lbs      | 7.1 N-m         | 2.14 ADJUST AND LUBRICATE STEERING HEAD BEARINGS, Lubricate   |
| Upper steering stem, final torque: Frame mounted fairing models                      | 192 in-lbs     | 21.7 N-m        | 2.14 ADJUST AND LUBRICATE STEERING HEAD BEARINGS, Lubricate   |
| Upper steering stem, final torque: Road King models                                  | 108 in-lbs     | 12.2 N-m        | 2.14 ADJUST AND LUBRICATE STEERING HEAD BEARINGS, Lubricate   |
| Upper steering stem, final torque: Trike models                                      | 108 in-lbs     | 12.2 N-m        | 2.14 ADJUST AND LUBRICATE STEERING HEAD BEARINGS, Lubricate   |
| Upper steering stem, first torque  | 35 ft-lbs      | 47.5 N-m        | 2.14 ADJUST AND LUBRICATE STEERING HEAD BEARINGS, Lubricate   |
| Upper support bracket to glovebox screw  | 2.0-3.0 ft-lbs | 2.7-4 N-m       | 3.30 FAIRING: FORK MOUNTED, Remove and Install: Glovebox  |
| Upper support bracket to inner fairing screw   | 0.8-1.6 ft-lbs | 1.1-2.2 N-m     | 3.30 FAIRING: FORK MOUNTED, Remove and Install: Glovebox  |



## Torque Values

| FASTENER  | TORQUE VALUE       |               | NOTES   |
|---|--------------------|---------------|---|
| Upper support bracket to speaker enclosure screw    | 4.0-5.0 ft-lbs     | 5.4-6.8 N-m   | 3.30 FAIRING: FORK MOUNTED, Remove and Install: Glovebox              |
| Upper support bracket to inner fairing screws       | 10-19 in-lbs       | 1.1-2.2 N-m   | 3.30 FAIRING: FORK MOUNTED, Remove and Install: Fairing               |
| Upper support bracket to radio (storage box) screws | 25-35 in-lbs       | 2.8-4 N-m     | 3.30 FAIRING: FORK MOUNTED, Remove and Install: Upper Support Bracket |
| Upper support bracket to speaker enclosure screws   | 48-60 in-lbs       | 5.4-6.8 N-m   | 3.30 FAIRING: FORK MOUNTED, Remove and Install: Upper Support Bracket |
| Valve stem  | 23-27 in-lbs       | 2.6-3 N-m     | 3.10 TIRE PRESSURE MONITORING SYSTEM (TPMS), Install                  |
| Valve stem nut                                      | 12-15 in-lbs       | 1.4-1.7 N-m   | 3.11 TIRES, Install   |
| Vent assembly to inner fairing screw                | 20-30 in-lbs       | 2.3-3.4 N-m   | 3.30 FAIRING: FORK MOUNTED, Disassemble and Assemble: Vent            |
| Voltage regulator screws                            | 96-120 in-lbs      | 10.8-13.6 N-m | <b>8.8</b> VOLTAGE REGULATOR, Install                                 |
| Windshield screws: Fork-mounted fairing models      | 25-30 in-lbs       | 2.8-3.4 N-m   | 3.30 FAIRING: FORK MOUNTED, Remove and Install: Windshield            |
| Windshield screws: Frame mounted fairing models     | <b>8-12</b> in-lbs | 0.9-1.4 N-m   | 3.31 FAIRING: FRAME MOUNTED, Remove and Install: Windshield           |
| Windshield screws: frame mounted fairing            | <b>8-12</b> in-lbs | 0.9-1.4 N-m   | 3.31 FAIRING: FRAME MOUNTED, Remove and Install: Outer Fairing Shell  |
| Windshield window screw Road King models            | 20-25 in-lbs       | 2.3-2.8 N-m   | 3.35 WINDSHIELD, Assemble   |
| Wrap-around lamp screws                             | 20-25 in-lbs       | 2.3-2.8 N-m   | 8.29 TOUR-PAK LIGHTING, Remove and Install: Wrap-Around Lamp          |

# Index

|  |       |   |       |
|--|-------|---|-------|
| ABS Module Remove and Install .....  | 3-58  | Brake Fluid, Drain and Replace .....                        | 2-24  |
| ABS Module, General .....  | 3-58  | Brake Line, Front Caliper to ABS Module .....               | 3-51  |
| Accessory Switches, Fork Mounted Fairing, Remove and Install .....           | 8-28  | Brake Line, Front Master Cylinder to ABS Module .....       | 3-48  |
| Accessory Switches, Frame Mounted Fairing, Remove and Install .....          | 8-28  | Brake Line, Rear Caliper to ABS Module .....                | 3-56  |
| Accessory Switches, Nacelle Mounted, Remove and Install .....                | 8-29  | Brake Line, Rear Master Cylinder to ABS Module .....        | 3-53  |
| Adhesive Strips Remove and Install .....                                     | 3-167 | Brake Lines, Inspect .....                                  | 2-25  |
| Adjust Auxiliary Lamps .....   | 8-48  | Brake Master Cylinder, Disassemble and Assemble .....       | 3-37  |
| Adjust Headlamp .....  | 8-43  | Brake Master Cylinder, Front, Clean and Inspect .....       | 3-38  |
| Air Cleaner Remove and Install .....   | 6-3   | Brake Master Cylinder, Front, Remove and Install .....      | 3-37  |
| Air Deflectors, Fork Mounted Fairing .....                                   | 3-119 | Brake Master Cylinder, Rear, Clean and Inspect .....        | 3-44  |
| Air Deflectors, Frame Mounted Fairing .....                                  | 3-119 | Brake Master Cylinder, Rear, Disassemble and Assemble ..... | 3-43  |
| Air Deflectors, Mid Frame .....  | 3-119 | Brake Master Cylinder, Rear, Remove and Install .....       | 3-42  |
| Air Filter, Clean and Inspect .....  | 2-46  | Brake Pads, Front, Replace .....                            | 2-20  |
| Air Filter, Remove and Install .....   | 2-46  | Brake Pads, Rear, Replace .....                             | 2-21  |
| Air Temperature Sensor, Ambient, Remove and Install .....                    | 8-94  | Brake Switch, Front, Replacement .....                      | 8-27  |
| Align Headlamp .....   | 8-42  | Brake Switch, Rear, Stoplamp, Remove and Install .....      | 8-65  |
| Alpha Step .....   | 1     | Brake Troubleshooting .....                                 | 2-57  |
| Alternator Remove and Install .....  | 8-12  | Brakes, Fill and Bleed .....                                | 3-60  |
| Ambient Air Temperature Sensor Remove and Install .....                      | 8-94  | Brakes, Fluid, Drain .....                                  | 3-60  |
| Antenna Cables, Extension, Models With Tour-Pak, Remove and Install .....    | 8-80  | Brakes, Inspect .....                                       | 2-19  |
| Antenna Cables, Extension, Models Without Tour-Pak, Remove and Install ..... | 8-81  | Breather Operation .....                                    | 4-10  |
| Antenna Cables, Main Cable, Remove and Install .....                         | 8-80  | Breathers Remove and Install .....                          | 4-26  |
| Antenna, GPS, Remove and Install .....                                       | 8-79  | Bulb Replacement, Front Turn Signal Lamps .....             | 8-49  |
| Antenna, Security System, Remove and Install .....                           | 8-90  | Bulb Replacement, Tail Lamp .....                           | 8-59  |
| Assemble Topic .....   | 1     |   |       |
| Audio Controls, Passenger, General .....                                     | 8-76  | CB Module Remove and Install .....                          | 8-78  |
| Automatic Compression Release Remove and Install .....                       | 8-98  | Cable Lubrication .....                                     | 2-18  |
| Auxiliary Lamps Adjust .....   | 8-48  | Caddy, Left Side, Remove and Install .....                  | 8-108 |
| Auxiliary Lamps Remove and Install .....                                     | 8-46  | Caddy, Lower Backbone, Remove and Install .....             | 8-112 |
|  |       | Caddy, Right Side, Remove and Install .....                 | 8-110 |
|  |       | Caddy, Top, Remove and Install .....                        | 8-107 |
|  |       | Caliper, Front, Remove and Install .....                    | 3-40  |
|  |       | Caliper, Rear, Remove and Install .....                     | 3-45  |
|  |       | Cam Compartment and Components Inspect .....                | 4-54  |
|  |       | Cam Compartment and Components Remove and Install .....     | 4-53  |
|  |       | Cam Drive Components Inspect .....                          | 4-54  |
|  |       | Cam Drive Components Remove and Install .....               | 4-53  |
|  |       | Cam Support Plate Inspect .....                             | 4-54  |
|  |       | Cam Support Plate Remove and Install .....                  | 4-53  |
|  |       | Camshaft Cover Remove and Install .....                     | 4-52  |
|  |       | Camshaft Inspect .....                                      | 4-54  |
|  |       | Camshaft Needle Bearings .....                              | 4-56  |
|  |       | Camshaft Remove and Install .....                           | 4-53  |
|  |       | Charcoal Canister Remove and Install .....                  | 6-38  |
|  |       | Chassis Lubrication .....                                   | 2-18  |
|  |       | Chassis Specifications .....                                | 3-8   |
|  |       | Check Valve, Oil, Remove and Install .....                  | 4-19  |
|  |       | Clamps, Crimp, Remove and Install .....                     | 4-16  |
|  |       | Cleaning .....  | 11    |
|  |       | Clutch Control Clean and Inspect .....                      | 3-81  |
|  |       | Clutch Control Disassemble and Assemble .....               | 3-84  |
|  |       | Clutch Control Remove and Install .....                     | 3-81  |
|  |       | Clutch Hub Disassemble and Assemble .....                   | 5-22  |
|  |       | Clutch Pack Disassemble and Assemble .....                  | 5-20  |
|  |       | Clutch Release Cover Clean and Inspect .....                | 5-9   |
|  |       | Clutch Release Cover Remove and Install .....               | 5-9   |
|  |       | Clutch Release Lever Disassemble and Assemble .....         | 5-9   |
|  |       | Clutch Release Push Rod Components .....                    | 5-12  |
|  |       | Clutch Remove and Install .....                             | 5-16  |
|  |       | Clutch Service Wear Limits .....                            | 5-2   |
| Badges Remove and Install .....  | 3-167 |   |       |
| Balance Wheels .....   | 3-34  |   |       |
| Battery .....  | 2-48  |   |       |
| Battery Tray Remove and Install .....  | 8-113 |   |       |
| Battery, Clean and Inspect .....   | 2-48  |   |       |
| Battery, Remove and Install .....  | 2-48  |   |       |
| Battery, Storage .....   | 2-49  |   |       |
| Battery, Voltage Test .....  | 2-48  |   |       |
| Bearing, Wheel .....   | 2-16  |   |       |
| Bearings, Wheel, Sealed, Inspect .....                                       | 3-26  |   |       |
| Bearings, Wheel, Sealed, Remove and Install .....                            | 3-26  |   |       |
| Belt Guards Remove and Install .....   | 3-79  |   |       |
| Belt, Drive, Remove and Install .....  | 5-6   |   |       |
| Bleed Brakes, Drain .....  | 3-60  |   |       |
| Bleed Brakes, Fill and Bleed .....   | 3-60  |   |       |
| Body Control Module Remove and Install .....                                 | 8-84  |   |       |
| Bracket, Mounting, Frame Mounted Fairing .....                               | 3-108 |   |       |
| Bracket, Radio Support, Frame Mounted Fairing .....                          | 3-109 |   |       |
| Bracket, Rear License Plate, Disassemble and Assemble .....                  | 3-141 |   |       |
| Bracket, Rear License Plate, Remove and Install .....                        | 3-141 |   |       |
| Bracket, Upper Support, Fork Mounted Fairing .....                           | 3-97  |   |       |
| Brake Caliper, Front, Remove and Install .....                               | 3-40  |   |       |
| Brake Caliper, Rear, Remove and Install .....                                | 3-45  |   |       |
| Brake Fluid Level, Check .....   | 2-24  |   |       |

# Index

|   |       |   |           |
|---|-------|---|-----------|
| Clutch Switch Replacement .....                                     | 8-24  | Disassemble Topics .....  | 1         |
| Clutch, Check and Adjust.....                                       | 2-27  | Downtubes, Coolant, Remove and Install.....                     | 7-15      |
| Coil, Ignition, Remove and Install .....                            | 8-20  | Drive Belt Deflection, Measure .....                            | 2-38      |
| Compensating Sprocket Remove and Install .....                      | 5-16  | Drive Belt Remove and Install .....                             | 5-6       |
| Compensator, Rear Wheel, Clean and Inspect .....                    | 3-25  | Drive Belt and Sprockets, Inspect.....                          | 2-37      |
| Compensator, Rear Wheel, Disassemble and Assemble..                 | 3-24  | Drive Belt, Adjust.....   | 2-39      |
| Compensator, Rear Wheel, Remove and Install .....                   | 3-24  | Drive Components Remove and Install .....                       | 5-16      |
| Complete Topic.....   | 1     | Drive Specification .....                                       | 5-2       |
| Compression Test.....   | 4-12  |   |           |
| Conduit, Rear Fender Wire, Remove and Install .....                 | 3-140 | Electrical Specifications.....                                  | 8-5       |
| Connecting Rods Inspect .....                                       | 4-73  | Electrical System Troubleshooting .....                         | 2-56      |
| Connecting Rods Symptoms .....                                      | 4-73  | Electronic Control Module Remove and Install .....              | 8-83      |
| Connector End Views .....   | A-67  | Emblems, Tank, Remove and Install .....                         | 3-167     |
| Console Remove and Install .....                                    | 6-5   | Engine Coolant Temperature (ECT) Sensor Remove and Install..... | 7-17      |
| Control Module, Left Hand, Clutch Switch Replacement..              | 8-24  | Engine Guard Remove and Install .....                           | 3-118     |
| Control Module, Left Hand, Remove and Install .....                 | 8-22  | Engine Lubrication .....  | 2-7       |
| Control Module, Left Hand, Switch Caps .....                        | 8-23  | Engine Mount, Lower Front, Remove and Install .....             | 4-22      |
| Control Module, Right Hand, Front Brake Switch Replacement.....     | 8-27  | Engine Mount, Upper Front, Remove and Install .....             | 4-22      |
| Control Module, Right Hand, Remove and Install.....                 | 8-25  | Engine Oil Flow .....   | 4-6       |
| Control Module, Right Hand, Switch Caps .....                       | 8-26  | Engine Oil and Filter, Change .....                             | 2-9       |
| Coolant .....   | 2-34  | Engine Oil and Filter, Check.....                               | 2-9       |
| Coolant Downtubes Remove and Install .....                          | 7-15  | Engine Remove and Install.....                                  | 4-61      |
| Coolant Flow .....  | 7-3   | Engine Service Wear Limits .....                                | 4-4       |
| Coolant Hoses Remove and Install .....                              | 7-13  | Engine Specifications .....                                     | 4-3       |
| Coolant Level Check.....  | 7-8   | Engine Temperature Sensor Remove and Install .....              | 8-96      |
| Coolant Lines Remove and Install.....                               | 7-14  | Engine Troubleshooting .....                                    | 2-54      |
| Coolant Overflow Tank Remove and Install .....                      | 7-12  | Enhanced Chassis Control.....                                   | 3-36      |
| Coolant Pump Remove and Install .....                               | 7-11  | Exhaust System Leak Check .....                                 | 2-45      |
| Coolant System, Horizontal Tube, Remove and Install .....           | 7-13  | Exhaust System Remove and Install .....                         | 6-34      |
| Coolant System, Radiator, Remove and Install .....                  | 7-18  |   |           |
| Coolant Temperature (ECT), Engine, Sensor, Remove and Install ..... | 7-17  | Fairing Gauges Remove and Install .....                         | 8-34      |
| Coolant, Drain and Fill System .....                                | 7-8   | Fairing Lower, Air-Cooled, Remove and Install.....              | 3-113     |
| Cooling Fan Remove and Install .....                                | 8-91  | Fairing Lower, Air-cooled, Disassemble and Assemble..           | 3-115     |
| Cooling System Specifications.....                                  | 7-2   | Fairing Lower, Twin-Cooled, Disassemble and Assemble .....      | 3-116     |
| Cooling System Gasket Leak Test.....                                | 7-7   | Fairing Lower, Twin-cooled, Remove and Install .....            | 3-113     |
| Cooling System Leak Detection Dye Test.....                         | 7-6   | Fairing Power Outlet Remove and Install .....                   | 8-10      |
| Cooling System Operation .....                                      | 7-3   | Fairing Wire Harness Remove and Install .....                   | 8-116     |
| Cooling System Pressure Cap Test.....                               | 7-5   | Fairing, Fork Mounted, Air Deflectors .....                     | 3-119     |
| Cooling System Pressure Test.....                                   | 7-5   | Fairing, Fork Mounted, Dash Panel.....                          | 3-92      |
| Cooling System Troubleshooting .....                                | 7-5   | Fairing, Fork Mounted, Detach for Service .....                 | 3-92      |
| Cooling System Freeze Point Test.....                               | 7-6   | Fairing, Fork Mounted, Headlamp Assembly.....                   | 3-91      |
| Cover, Left Side, Remove and Install.....                           | 3-62  | Fairing, Fork Mounted, Inner Fairing Shell .....                | 3-95      |
| Cover, Right Side, Remove and Install .....                         | 3-63  | Fairing, Fork Mounted, Media Compartment .....                  | 3-98      |
| Crankcase Clean and Inspect .....                                   | 4-64  | Fairing, Fork Mounted, Outer Fairing Shell .....                | 3-89      |
| Crankcase Disassemble and Assemble .....                            | 4-63  | Fairing, Fork Mounted, Perimeter Trim.....                      | 3-90      |
| Crankcase, Left Half, Repair .....                                  | 4-68  | Fairing, Fork Mounted, Remove and Install .....                 | 3-93      |
| Crankcase, Right Half, Repair.....                                  | 4-66  | Fairing, Fork Mounted, Upper Support Bracket .....              | 3-97      |
| Crankshaft Position Sensor Remove and Install .....                 | 8-95  | Fairing, Fork Mounted, Vent.....                                | 3-96      |
| Crankshaft Runout, Measure .....                                    | 4-13  | Fairing, Fork Mounted, Vent Bezel.....                          | 3-91,3-96 |
| Crimp Clamps Remove and Install .....                               | 4-16  | Fairing, Fork Mounted, Windshield.....                          | 3-89      |
| Cylinder Heads Clean .....  | 4-37  | Fairing, Frame Mounted, Air Deflectors.....                     | 3-119     |
| Cylinder Heads Clean and Inspect.....                               | 4-38  | Fairing, Frame Mounted, Inner Fairing Shell .....               | 3-107     |
| Cylinder Heads Disassemble and Assemble .....                       | 4-38  | Fairing, Frame Mounted, Instrument Bezel .....                  | 3-104     |
| Cylinder Heads Remove and Install .....                             | 4-36  | Fairing, Frame Mounted, Instrument Nacelle .....                | 3-104     |
| Cylinder Leakdown Test .....  | 4-12  | Fairing, Frame Mounted, Lower Vents.....                        | 3-103     |
| Cylinder Studs .....  | 4-71  | Fairing, Frame Mounted, Media Cable.....                        | 3-112     |
| Cylinder, Deglaze .....   | 4-44  | Fairing, Frame Mounted, Mounting Bracket .....                  | 3-108     |
| Cylinders, Clean and Inspect .....                                  | 4-44  | Fairing, Frame Mounted, Outer Fairing Shell .....               | 3-102     |
| Cylinders, Remove and Install.....                                  | 4-42  |   |           |
| Dash Panel, Fork Mounted Fairing .....                              | 3-92  |   |           |
| Deglaze Cylinder .....  | 4-44  |   |           |
| Detach Fairing for Service, Fork Mounted Fairing .....              | 3-92  |   |           |
| Diagnose Smoking Engine or High Oil Consumption .....               | 4-14  |   |           |
| Diagnose Valve Train Noise .....                                    | 4-14  |   |           |

# Index

|  |       |
|--|-------|
| Fairing, Frame Mounted, Radio Support Bracket                | 3-109 |
| Fairing, Frame Mounted, Remove and Install                   | 3-105 |
| Fairing, Frame Mounted, Storage Compartment Doors and Hinges | 3-110 |
| Fairing, Frame Mounted, Storage Compartments                 | 3-111 |
| Fairing, Frame Mounted, Upper Vent                           | 3-100 |
| Fairing, Frame Mounted, Windshield                           | 3-100 |
| Fan, Cooling, Remove and Install                             | 8-91  |
| Fender Tip Lamp Remove and Install                           | 8-52  |
| Fender Tip Lamp, Facia Lamp, Remove and Install              | 8-61  |
| Fender, Front, Disassemble and Assemble                      | 3-134 |
| Fender, Front, Remove and Install                            | 3-134 |
| Fender, Rear, Disassemble and Assemble                       | 3-138 |
| Fender, Rear, Remove and Install                             | 3-137 |
| Fender, Rear, Wire Conduit, Remove and Install               | 3-140 |
| Filter, Fuel, Remove and Install                             | 6-12  |
| Flywheel Inspect   | 4-73  |
| Flywheel Symptoms  | 4-73  |
| Fob Battery  | 8-87  |
| Footrests, Passenger, Disassemble and Assemble               | 3-145 |
| Footrests, Passenger, Remove and Install                     | 3-144 |
| Footrests, Rider, Disassemble and Assemble                   | 3-142 |
| Footrests, Rider, Remove and Install                         | 3-142 |
| Fork Stem and Bracket Remove and Install                     | 3-71  |
| Fork, Front, Clean and Inspect                               | 3-68  |
| Fork, Front, Disassemble and Assemble                        | 3-66  |
| Fork, Front, Remove and Install                              | 3-64  |
| Fork, Rear, Disassemble and Assemble                         | 3-76  |
| Fork, Rear, Remove and Install                               | 3-75  |
| Frame, Rear, Remove and Install                              | 3-151 |
| Freeze Point Test  | 7-6   |
| Front Fender Disassemble and Assemble                        | 3-134 |
| Front Fender Remove and Install                              | 3-134 |
| Front Fork Clean and Inspect                                 | 3-68  |
| Front Fork Disassemble and Assemble                          | 3-66  |
| Front Fork Remove and Install                                | 3-64  |
| Front Wheel Clean and Inspect                                | 3-13  |
| Front Wheel Disassemble and Assemble                         | 3-13  |
| Front Wheel Remove and Install                               | 3-12  |
| Fuel Injectors Remove and Install                            | 6-25  |
| Fuel   | 2-7   |
| Fuel Filter Remove and Install                               | 6-12  |
| Fuel Level Gauge Remove and Install                          | 8-35  |
| Fuel Line Remove and Install                                 | 6-8   |
| Fuel Line, Purge   | 6-7   |
| Fuel Line, Vent Tube, Remove and Install                     | 6-19  |
| Fuel Pressure Regulator Remove and Install                   | 6-12  |
| Fuel Pressure Test   | 6-6   |
| Fuel Pump Clean and Inspect                                  | 6-16  |
| Fuel Pump Disassemble and Assemble                           | 6-17  |
| Fuel Pump Remove and Install                                 | 6-16  |
| Fuel Pump Specifications                                     | 6-2   |
| Fuel Tank Remove and Install                                 | 6-10  |
| Fuel Tank Top Plate Disassemble and Assemble                 | 6-12  |
| Fuel Tank Top Plate Remove and Install                       | 6-11  |
| Fuses Remove and Install                                     | 8-6   |

## G

|  |      |
|--|------|
| GPS Antenna Remove and Install         | 8-79 |
| Gasoline Blends                        | 2-7  |
| Gauge, Fuel Level, Remove and Install  | 8-35 |
| General                                | I    |
| General, Cable and Chassis Lubrication | 2-18 |
| Glovebox Remove and Install            | 3-90 |

## H

|  |             |
|--|-------------|
| Hand Grips Remove and Install                            | 3-123,3-123 |
| Handlebar Disassemble and Assemble                       | 3-129       |
| Handlebar, Adjust  | 3-130       |
| Handlebar, Fork Mounted Fairing, Remove and Install      | 3-126       |
| Handlebar, Frame Mounted Fairing, Remove and Install     | 3-128       |
| Handlebar, Without Fairing, Remove and Install           | 3-125       |
| Handling Troubleshooting                                 | 2-56        |
| Harness, Fairing, Remove and Install                     | 8-116       |
| Harness, Main, Fork Mounted Fairing, Remove and Install  | 8-119       |
| Harness, Main, Frame Mounted Fairing, Remove and Install | 8-121       |
| Harness, Main, Without Fairing, Remove and Install       | 8-122       |
| Harness, Tour-Pak, Remove and Install                    | 8-114       |
| Headlamp Adjustment                                      | 8-43        |
| Headlamp Alignment                                       | 8-42        |
| Headlamp Assembly, Fork Mounted Fairing                  | 3-91        |
| Headlamp Nacelle Remove and Install                      | 3-87        |
| Headlamp, Dual, Remove and Install                       | 8-42        |
| Headlamp, Single, Remove and Install                     | 8-41        |
| Heads, Cylinder, Clean                                   | 4-37        |
| Heads, Cylinder, Clean and Inspect                       | 4-38        |
| Heads, Cylinder, Disassemble and Assemble                | 4-38        |
| Heads, Cylinder, Remove and Install                      | 4-36        |
| Headset Connector, Rider, Remove and Install             | 8-77        |
| Heated Oxygen Sensors Remove and Install                 | 6-31        |
| Horn Disassemble and Assemble                            | 8-39        |
| Horn Remove and Install                                  | 8-38        |
| Hub, Angle Flange, Wheel Lacing                          | 3-17        |

## I

|   |       |
|---|-------|
| IMU Remove and Install                                  | 8-103 |
| Icons   | I     |
| Ignition Coil Remove and Install                        | 8-20  |
| Ignition Switch, Fairing Models, Remove and Install     | 8-16  |
| Ignition Switch, Non-Fairing Models, Remove and Install | 8-17  |
| Indicator Lamps Remove and Install                      | 8-33  |
| Induction Module Disassemble and Assemble               | 6-28  |
| Induction Module Remove and Install                     | 6-26  |
| Injectors, Fuel, Remove and Install                     | 6-25  |
| Inspect Brakes  | 2-19  |
| Install Topics  | I     |
| Instrument Bezel, Frame Mounted Fairing                 | 3-104 |
| Instrument Module Remove and Install                    | 8-31  |
| Instrument Nacelle, Frame Mounted Fairing               | 3-104 |
| Intake Leak Test  | 6-30  |
| Isolator, Rear Sprocket, Inspect                        | 2-42  |





# Index

|  |       |
|--|-------|
| Jiffy Stand Remove and Install.....        | 3-146 |
| Jiffy Stand Sensor Remove and Install..... | 8-104 |

|                                   |      |
|-----------------------------------|------|
| Motorcycle Storage .....          | 2-52 |
| Mufflers Remove and Install ..... | 6-33 |

## K

|                                       |      |
|---------------------------------------|------|
| Knock Sensor Remove and Install ..... | 8-97 |
|---------------------------------------|------|

## L

|   |             |
|---|-------------|
| Layout.....   | I           |
| Leak Test, Intake .....                                     | 6-30        |
| Left Side Caddy Remove and Install .....                    | 8-108       |
| Left Side Cover Remove and Install.....                     | 3-62        |
| License Plate Bracket, Rear, Remove and Install .....       | 3-141       |
| License Plate Bracket, Rear,, Disassemble and Assemble..... | 3-141       |
| License Plate Lamp, General .....                           | <b>8-66</b> |
| Lifters Clean and Inspect .....                             | 4-33        |
| Lifters Inspect .....                                       | 4-33        |
| Lifters Remove and Install.....                             | 4-32        |
| Loctite .....   | 11 I        |
| Lower Backbone Caddy Remove and Install.....                | 8-112       |
| Lower Rocker Covers Remove and Install .....                | 4-28        |
| Lubricant, Primary Chaincase, Change.....                   | 2-11        |
| Lubricant, Transmission, Change .....                       | 2-13        |
| Lubricant, Transmission, Check .....                        | 2-13        |
| Lubrication Points .....                                    | 2-18        |
| Lubrication System Troubleshooting.....                     | 2-55        |
| Lubrication, Engine .....                                   | 2-7         |
| Lubrication, Winter.....                                    | 2-8         |

## M

|  |              |
|--|--------------|
| Main Drive Gear and Bearing Disassemble and Assemble.....                | 5-43         |
| Main Drive Gear and Bearing Remove and Install .....                     | 5-42         |
| Main Wire Harness, Fork Mounted Fairing, Remove and Install .....        | 8-119        |
| Main Wire Harness, Frame Mounted Fairing, Remove and Install .....       | <b>8-121</b> |
| Main Wire Harness, Without Fairing, Remove and Install.....              | 8-122        |
| Mainshaft Bearing Inner Race Remove and Install .....                    | 5-27         |
| Mainshaft Bearing and Seal Remove and Install.....                       | 5-26         |
| Mainshaft Needle Bearing Remove and Install .....                        | 5-44         |
| Mainshaft Seal Remove and Install.....                                   | 5-45         |
| Maintenance .....  | 2-3          |
| Maintenance Schedule .....   | 2-4          |
| Manifold Absolute Pressure Sensor, Temperature, Remove and Install ..... | <b>6-21</b>  |
| Manual.....  | 1,1          |
| Master Cylinder, Front Brake, Clean and Inspect.....                     | 3-38         |
| Master Cylinder, Front Brake, Disassemble and Assemble.....              | 3-37         |
| Master Cylinder, Front Brake, Remove and Install .....                   | 3-37         |
| Master Cylinder, Rear Brake, Clean and Inspect .....                     | 3-44         |
| Master Cylinder, Rear Brake, Disassemble and Assemble.....               | 3-43         |
| Master Cylinder, Rear Brake, Remove and Install.....                     | 3-42         |
| Medallions Remove and Install .....                                      | 3-167        |
| Media Cable, Frame Mounted Fairing.....                                  | 3-112        |
| Media Compartment, Fork Mounted Fairing.....                             | 3-98         |
| Mirrors, Fairing Mount, Remove and Install.....                          | 3-132        |
| Mirrors, Handlebar Mount, Remove and Install .....                       | 3-132        |

|   |       |
|---|-------|
| Nacelle, Headlamp, Remove and Install.....        | 3-87  |
| Nacelle, Instrument, Frame Mounted Fairing .....  | 3-104 |
| Neutral Indicator Switch Remove and Install ..... | 8-37  |
| Numeric Step .....                                | I     |

|   |      |
|---|------|
| Oil Check Valve Remove and Install .....              | 4-19 |
| Oil Consumption, High, Diagnose .....                 | 4-14 |
| Oil Coolant Lines Remove and Install.....             | 4-20 |
| Oil Cooler and Downtube Disassemble and Assemble..... | 4-17 |
| Oil Cooler and Downtube Remove and Install .....      | 4-17 |
| Oil Flow, Engine .....                                | 4-6  |
| Oil Leak Check, Front Fork .....                      | 3-64 |
| Oil Pan Remove and Install .....                      | 4-75 |
| Oil Pressure Check .....                              | 4-11 |
| Oil Pressure Operation .....                          | 4-11 |
| Oil Pressure Switch Remove and Install.....           | 8-36 |
| Oil Pump Operation.....                               | 4-9  |
| Oil Pump Operation, General .....                     | 4-9  |
| Oil Pump Remove and Install .....                     | 4-58 |
| Oil Pump, Disassemble, Inspect and Assemble .....     | 4-58 |
| Oil and Filter, Engine, Change .....                  | 2-9  |
| Oil and Filter, Engine, Check.....                    | 2-9  |
| Oil, Primary Chaincase, Change .....                  | 2-11 |
| Order of Operation .....                              | I    |
| Overflow Tank, Coolant, Remove and Install.....       | 7-12 |
| Oxygen Sensors, Heated, Remove and Install .....      | 6-31 |

|   |            |
|---|------------|
| Passenger Audio Controls, General .....                                       | 8-76       |
| Passenger Footrests Disassemble and Assemble .....                            | 3-145      |
| Passenger Footrests Remove and Install .....                                  | 3-144      |
| Piston Ring Gap Check.....  | 4-49       |
| Pistons Clean and Inspect.....  | 4-48       |
| Pistons Disassemble and Assemble .....  | 4-48       |
| Pistons Remove and Install .....  | 4-46       |
| Plugs and Oil Fittings .....  | 4-71       |
| Power Disconnect .....  | <b>8-8</b> |
| Power Disconnect, Main Fuse.....  | <b>8-8</b> |
| Power Outlet, Fairing, Remove and Install .....                               | 8-10       |
| Prepare Topic.....  | I          |
| Pressure Cap, Cooling System, Test .....                                      | 7-5        |
| Pressure Test, Cooling System .....   | 7-5        |
| Primary Chaincase Cover Remove and Install .....                              | 5-14       |
| Primary Chaincase Housing Inspect.....  | 5-25       |
| Primary Chaincase Housing, Mainshaft Bearing and Seal Remove and Install..... | 5-26       |
| Primary Chaincase Housing, Vent Hose, Remove and Install.....                 | 5-28       |
| Primary Chaincase Lubricant, Change .....                                     | 2-11       |



# Index

|   |       |  |        |
|---|-------|--|--------|
| Primary Chaincase Housing Remove and Install .....        | 5-25  | Shell, Outer Fairing, Frame Mounted Fairing .....                      | 3-102  |
| Pump, Oil, Operation .....                                | 4-9   | Shift Lever, Foot, Remove and Install .....                            | 5-7    |
| Purge Lines Remove and Install .....                      | 6-39  | Shift Rod Lever, Front .....   | 5-8    |
| Purge Solenoid Remove and Install .....                   | 6-37  | Shifter Rod Remove and Install .....                                   | 5-7    |
| Pushrod Covers Assemble .....                             | 4-34  | Shifter Shaft Bushing Remove and Install .....                         | 5-27   |
| Pushrod Covers Clean and Inspect .....                    | 4-33  | Shock Absorber, Adjust .....   | 2-43   |
| Pushrod Covers Remove and Install .....                   | 4-32  | Shock Absorber, Rear, Clean and Inspect .....                          | 3-80   |
| Pushrods Clean and Inspect .....                          | 4-33  | Shock Absorber, Rear, Disassemble and Assemble .....                   | 3-80   |
| Pushrods Remove and Install .....                         | 4-32  | Shock Absorber, Rear, Remove and Install .....                         | 3-80   |
|   |       | Shop Practices .....   | 11,III |
|   |       | Side Cover, Left, Remove and Install .....                             | 3-62   |
|   |       | Side Cover, Right, Remove and Install .....                            | 3-63   |
|   |       | Siren, Security System, Remove and Install .....                       | 8-89   |
|   |       | Smoking Engine, Diagnose .....   | 4-14   |
|   |       | Solenoid, Purge, Remove and Install .....                              | 6-37   |
|   |       | Spark Plug .....   | 2-50   |
|   |       | Spark Plug Cables Remove and Install .....                             | 8-19   |
|   |       | Spark Plugs, Clean and Inspect .....                                   | 2-50   |
|   |       | Spark Plugs, Remove and Install .....                                  | 2-50   |
|   |       | Speakers, Front, Fork Mounted Fairing, Remove and Install .....        | 8-70   |
|   |       | Speakers, Front, Frame Mounted Fairing, Remove and Install .....       | 8-71   |
|   |       | Speakers, Rear, Disassemble and Assemble .....                         | 8-74   |
|   |       | Speakers, Rear, Remove and Install .....                               | 8-73   |
|   |       | Special Tools .....  | 111    |
|   |       | Specifications, Chassis .....  | 3-8    |
|   |       | Specifications, Electrical .....                                       | 8-5    |
|   |       | Specifications, Fuel Pump .....  | 6-2    |
|   |       | Spoke, Wheel Lacing, Angle Flange Hub .....                            | 3-17   |
|   |       | Spokes, Wheel .....  | 2-16   |
|   |       | Sprocket Isolator, Rear, Inspect .....                                 | 2-42   |
|   |       | Sprocket Shaft Bearing Inner Race .....                                | 4-69   |
|   |       | Stand, Jiffy, Remove and Install .....                                 | 3-146  |
|   |       | Starter Remove and Install .....                                       | 8-11   |
|   |       | Steering Head Bearings, Check and Adjust .....                         | 2-31   |
|   |       | Steering Head Bearings, Lubricate .....                                | 2-33   |
|   |       | Steering Head Remove and Install .....                                 | 3-71   |
|   |       | Stoplamp Switch, Rear, Remove and Install .....                        | 8-65   |
|   |       | Storage Compartment Doors and Hinges, Frame Mounted Fairing .....      | 3-110  |
|   |       | Storage Compartments, Frame Mounted Fairings .....                     | 3-111  |
|   |       | Storage, Place Motorcycle in .....                                     | 2-52   |
|   |       | Storage, Remove Motorcycle from .....                                  | 2-53   |
|   |       | Symbols .....  | I      |
|   |       |  |        |
|   |       | Tank Emblems Remove and Install .....                                  | 3-167  |
|   |       | Temperature Sensor, Engine, Remove and Install .....                   | 8-96   |
|   |       | Temperature Manifold Absolute Pressure Sensor Remove and Install ..... | 6-21   |
|   |       | Test, Compression .....  | 4-12   |
|   |       | Test, Cylinder Leakdown .....  | 4-12   |
|   |       | Test, Fuel Pressure .....  | 6-6    |
|   |       | Test, Intake Leak .....  | 6-30   |
|   |       | Tire Pressure Monitoring System (TPMS) .....                           | 3-29   |
|   |       | Tire Runout, Check .....   | 3-34   |
|   |       | Tires .....  | 3-32   |
|   |       | Tires, Clean, Inspect and Repair .....                                 | 3-32   |
|   |       | Tires, General .....   | 2-15   |
|   |       | Tires, Inspect .....   | 2-16   |
|   |       | Tires, Remove and Install .....  | 3-31   |
|   |       | Tires, Replace .....   | 2-16   |
|   |       | Tool .....   | III    |
|   |       | Top Caddy Remove and Install .....                                     | 8-107  |
| Radiator Remove and Install .....                         | 7-18  |  |        |
| Radiator, Clean .....                                     | 2-34  |  |        |
| Radio, Fork Mounted Fairing, Remove and Install .....     | 8-67  |  |        |
| Radio, Frame Mounted Fairing, Remove and Install .....    | 8-68  |  |        |
| Rear Fender Disassemble and Assemble .....                | 3-138 |  |        |
| Rear Fender Remove and Install .....                      | 3-137 |  |        |
| Rear Fender Wire Conduit Remove and Install .....         | 3-140 |  |        |
| Rear Fork Disassemble and Assemble .....                  | 3-76  |  |        |
| Rear Fork Remove and Install .....                        | 3-75  |  |        |
| Rear Frame Remove and Install .....                       | 3-151 |  |        |
| Rear License Plate Bracket Disassemble and Assemble ..... | 3-141 |  |        |
| Rear License Plate Bracket Remove and Install .....       | 3-141 |  |        |
| Rear Shock Absorber Clean and Inspect .....               | 3-80  |  |        |
| Rear Shock Absorber Disassemble and Assemble .....        | 3-80  |  |        |
| Rear Shock Absorber Remove and Install .....              | 3-80  |  |        |
| Rear Wheel Clean and Inspect .....                        | 3-16  |  |        |
| Rear Wheel Disassemble and Assemble .....                 | 3-16  |  |        |
| Rear Wheel Remove and Install .....                       | 3-14  |  |        |
| Reflex Defensive Rider System .....                       | 3-36  |  |        |
| Regulator, Fuel Pressure, Remove and Install .....        | 6-12  |  |        |
| Regulator, Voltage, Remove and Install .....              | 8-14  |  |        |
| Relays Remove and Install .....                           | 8-6   |  |        |
| Remove Topic .....  | I     |  |        |
| Right Side Caddy Remove and Install .....                 | 8-110 |  |        |
| Right Side Cover Remove and Install .....                 | 3-63  |  |        |
| Ring Gap, Pistons, Check .....                            | 4-49  |  |        |
| Rocker Arms Clean and Inspect .....                       | 4-30  |  |        |
| Rocker Arms Remove and Install .....                      | 4-30  |  |        |
| Rocker Covers, Lower, Remove and Install .....            | 4-28  |  |        |
| Rocker Covers, Upper, Remove and Install .....            | 4-24  |  |        |
| Runout, Checking Wheel .....                              | 3-22  |  |        |
| Runout, Tire, Check .....                                 | 3-34  |  |        |
| Shell, Inner Fairing, Fork Mounted Fairing .....          | 3-95  |  |        |
| Shell, Inner Fairing, Frame Mounted Fairing .....         | 3-107 |  |        |
| Shell, Outer Fairing, Fork Mounted Fairing .....          | 3-89  |  |        |
| Saddlebag Supports Remove and Install .....               | 3-165 |  |        |
| Saddlebags Disassemble and Assemble .....                 | 3-161 |  |        |
| Saddlebags Remove and Install .....                       | 3-161 |  |        |
| Safety .....  | 1-1   |  |        |
| Schedule, Maintenance .....                               | 2-4   |  |        |
| Seat Remove and Install .....                             | 3-148 |  |        |
| Secure Motorcycle for Service .....                       | 2-3   |  |        |
| Security Siren Battery .....                              | 8-87  |  |        |
| Security Siren Remove and Install .....                   | 8-89  |  |        |
| Security System Activation .....                          | 8-85  |  |        |
| Security System Antenna Remove and Install .....          | 8-90  |  |        |
| Security System Maintenance .....                         | 8-87  |  |        |
| Security System, Changing the PIN .....                   | 8-86  |  |        |
| Service Mode .....  | 8-87  |  |        |
| Service Wear Limits, Engine .....                         | 4-4   |  |        |
| Servicing a New Motorcycle .....                          | 2-3   |  |        |
| Tail Lamp Bulb Replacement .....                          | 8-59  |  |        |
| Tail Lamp Remove and Install .....                        | 8-59  |  |        |

# Index

|   |       |  |       |
|---|-------|--|-------|
| Top Plate, Fuel Tank, Disassemble and Assemble .....                | 6-12  | Twist Grip Sensor Remove and Install .....                     | 6-22  |
| Top Plate, Fuel Tank, Remove and Install .....                      | 6-11  | Vent Bezel, Fork Mounted Fairing .....                         | 3-91  |
| Tour-Pak Disassemble and Assemble .....                             | 3-155 | Vent Hose, Primary Chaincase Housing, Remove and Install ..... | 5-28  |
| Tour-Pak Lighting, Side Lamps/Trim Strips, Remove and Install ..... | 8-62  | Vent, Fork Mounted Fairing .....                               | 3-96  |
| Tour-Pak Lighting, Wrap-Around Lamp, Remove and Install .....       | 8-63  | Vent, Upper, Frame Mounted Fairing .....                       | 3-100 |
| Tour-Pak Remove and Install .....                                   | 3-153 | Vents, Lower, Frame Mounted Fairing .....                      | 3-103 |
| Tour-Pak Support Disassemble and Assemble .....                     | 3-159 | Voltage Regulator Remove and Install .....                     | 8-14  |
| Tour-Pak Support Remove and Install .....                           | 3-159 |  |       |
| Tour-Pak Wire Harness Remove and Install .....                      | 8-114 |  |       |
| Trademarks .....  | IIUII |  |       |
| Transmission Case Clean and Inspect .....                           | 5-48  | Wear Limits, Service, Engine .....                             | 4-4   |
| Transmission Case Disassemble and Assemble .....                    | 5-48  | Wheel Bearings .....   | 2-16  |
| Transmission Case Remove and Install .....                          | 5-47  | Wheel Bearings, Sealed, Inspect .....                          | 3-26  |
| Transmission Clean and Inspect .....                                | 5-37  | Wheel Bearings, Sealed, Remove and Install .....               | 3-26  |
| Transmission Disassemble and Assemble .....                         | 5-33  | Wheel Compensator, Rear, Clean and Inspect .....               | 3-25  |
| Transmission Lubricant, Change .....                                | 2-13  | Wheel Compensator, Rear, Disassemble and Assemble .....        | 3-24  |
| Transmission Lubricant, Check .....                                 | 2-13  | Wheel Compensator, Rear, Remove and Install .....              | 3-24  |
| Transmission Operation .....  | 5-4   | Wheel Lacing, 16 inch Rear Wheel .....                         | 3-18  |
| Transmission Remove and Install .....                               | 5-32  | Wheel Lacing, Angle Flange Hub .....                           | 3-17  |
| Transmission Specifications .....                                   | 5-2   | Wheel Speed Sensor, Front, Remove and Install .....            | 8-100 |
| Transmission Sprocket Remove and Install .....                      | 5-29  | Wheel Speed Sensor, Rear, Remove and Install .....             | 8-102 |
| Transmission Troubleshooting .....                                  | 2-56  | Wheel Spokes .....   | 2-16  |
| Transport Mode .....  | 8-87  | Wheel, Front, Clean and Inspect .....                          | 3-13  |
| Trim, Perimeter, Fork Mounted Fairing .....                         | 3-90  | Wheel, Front, Disassemble and Assemble .....                   | 3-13  |
| Troubleshooting, Brakes .....                                       | 2-57  | Wheel, Front, Remove and Install .....                         | 3-12  |
| Troubleshooting, Electrical System .....                            | 2-56  | Wheel, Rear, Clean and Inspect .....                           | 3-16  |
| Troubleshooting, Engine .....                                       | 2-54  | Wheel, Rear, Disassemble and Assemble .....                    | 3-16  |
| Troubleshooting, General .....                                      | 2-54  | Wheel, Rear, Remove and Install .....                          | 3-14  |
| Troubleshooting, Handling .....                                     | 2-56  | Wheels, Balance .....  | 3-34  |
| Troubleshooting, Lubrication System .....                           | 2-55  | Wheels, Checking Wheel Runout .....                            | 3-22  |
| Troubleshooting, Transmission .....                                 | 2-56  | Wheels, Checking and Truing, General .....                     | 3-22  |
| Turn Signal Lamps, Front, Bulb Replacement .....                    | 8-49  | Wheels, General .....  | 2-15  |
| Turn Signal Lamps, Front, Handlebar Mount, Remove and Install ..... | 8-50  | Windshield Disassemble and Assemble .....                      | 3-121 |
| Turn Signal Lamps, Front, Light Bar Mount, Remove and Install ..... | 8-50  | Windshield Remove and Install .....                            | 3-121 |
| Turn Signal Lamps, Rear, Bulb Replacement .....                     | 8-54  | Windshield, Fork Mounted Fairing .....                         | 3-89  |
| Turn Signal Lamps, Rear, Bullet Style, Remove and Install .....     | 8-54  | Windshield, Frame Mounted Fairing .....                        | 3-100 |
| Turn Signal Lamps, Rear, Flat Lens Style, Remove and Install .....  | 8-56  | Winter Lubrication .....                                       | 2-8   |
|   |       | Wire Conduit, Rear Fender, Remove and Install .....            | 3-140 |
|   |       | Wire Trough Remove and Install .....                           | 8-105 |
|   |       | Wiring Diagrams .....  | A-2   |
| Upper Rocker Covers Remove and Install .....                        | 4-24  |  |       |
| Using the Manual .....  | I     |  |       |
| Valve Train Noise, Diagnose .....                                   | 4-14  |  |       |
| Valve and Seat Repair .....   | 4-39  |  |       |
| Vehicle Identification Number (VIN) .....                           | 3-10  |  |       |



## NOTES