

Band Saw Dump Truck

By: Acutabove Woodworking

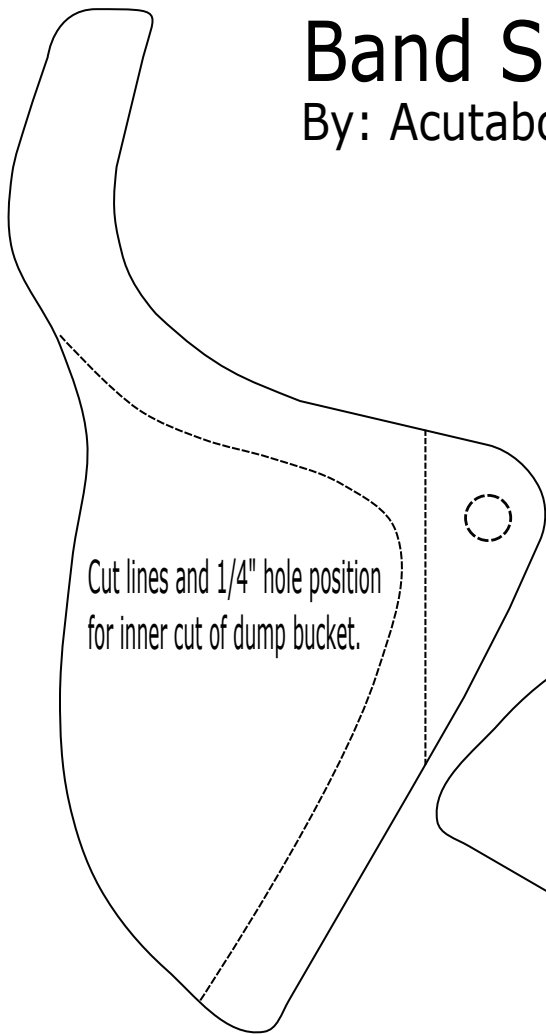

Wheels. Make 4 @ 1/2" thick, 1" dia.

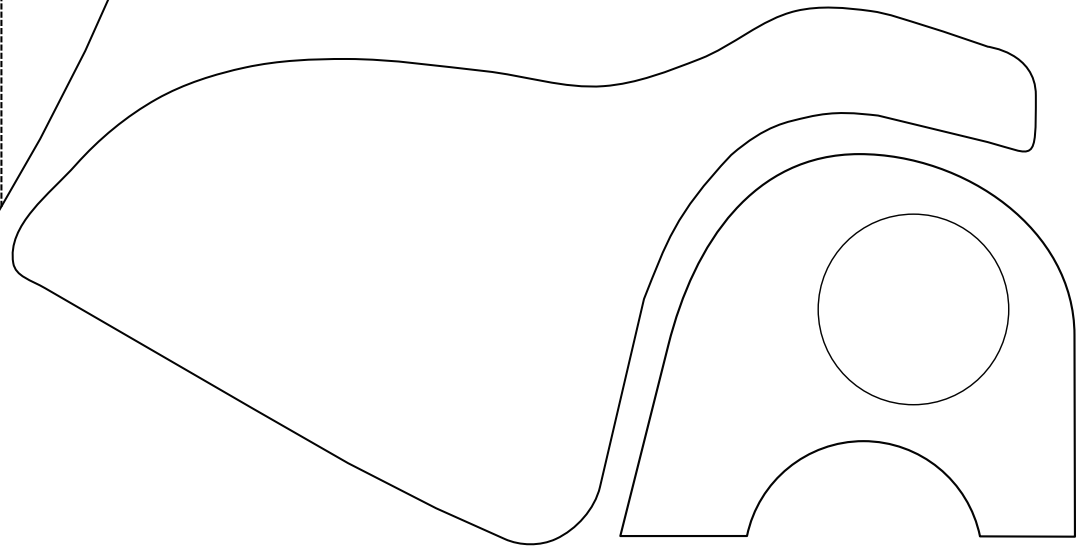
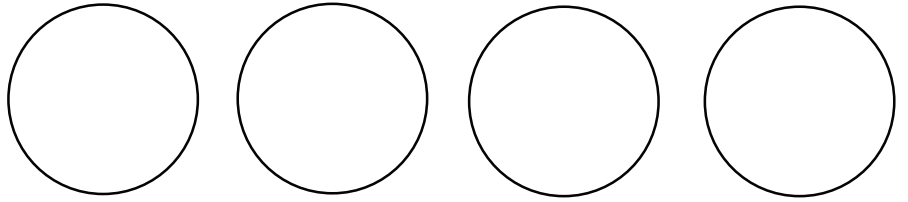

Cutting pattern for truck cab and exterior cuts of the dump bucket.

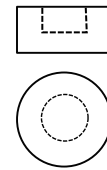
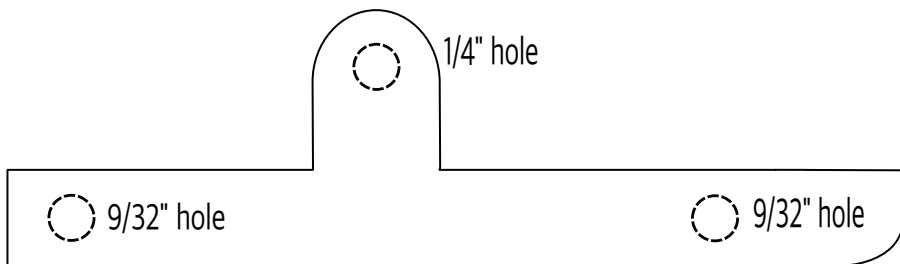

Axle Caps. Make 6 from 1/2" dia dowel with a

1/4" dia hole, 1/8" deep.

Main frame. Cut one.
Thickness is determined
by the width of the truck

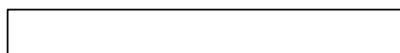

Bucket Axle. Make one from 1/4" dia dowel, 2-1/16" long

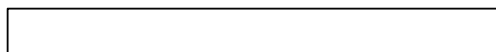

Wheel Axle. Make two from 1/4" dia dowel, 2-9/16" long