

**Acutabove Woodworkings**

**Classic Phone Toy**

**www.acutabovewoodworkings.com**

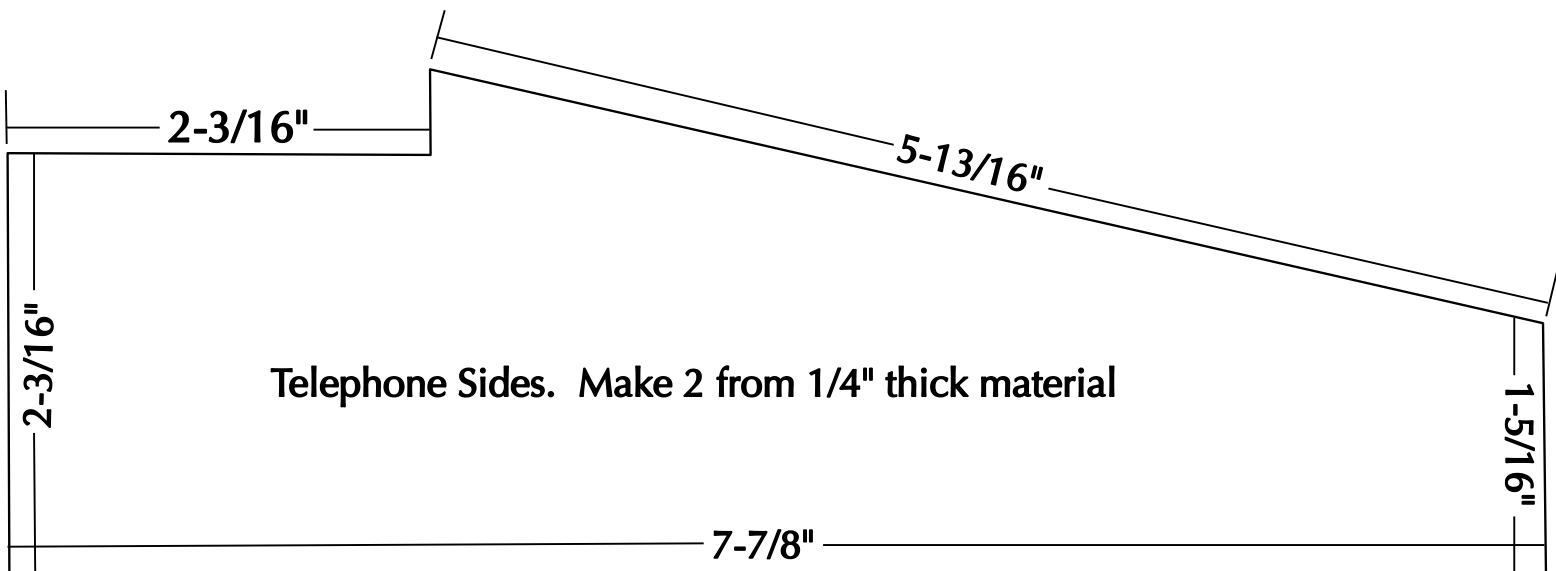
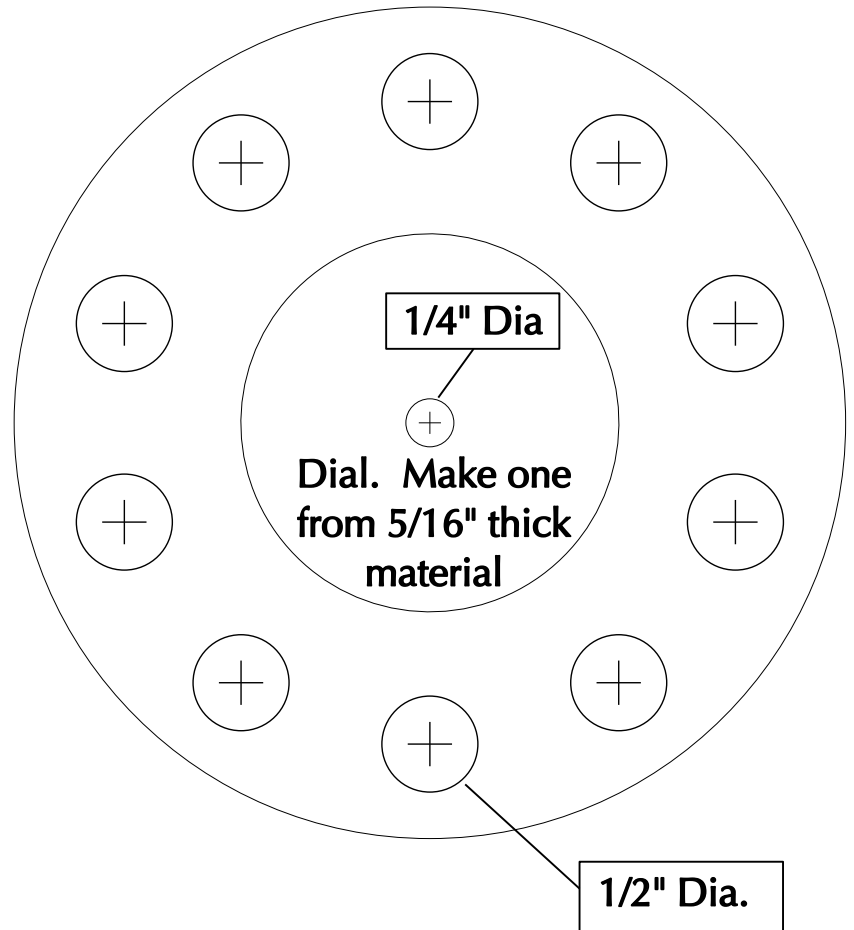
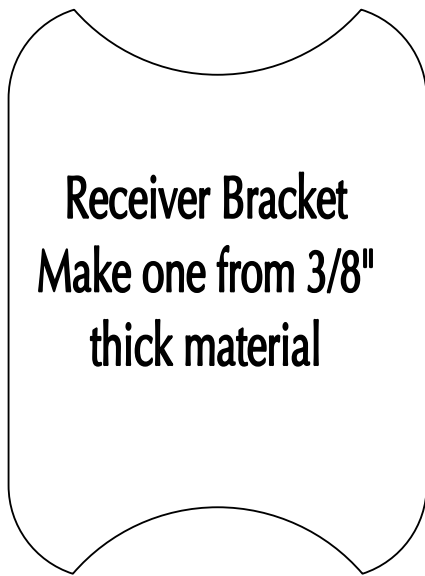

**Acutabove Woodworkings**  
**Classic Phone Toy**  
[www.acutabovewoodworkings.com](http://www.acutabovewoodworkings.com)

2" Dia.

Receiver Ear and Mouth Piece.  
Make 2 from 3/4" Thick Material

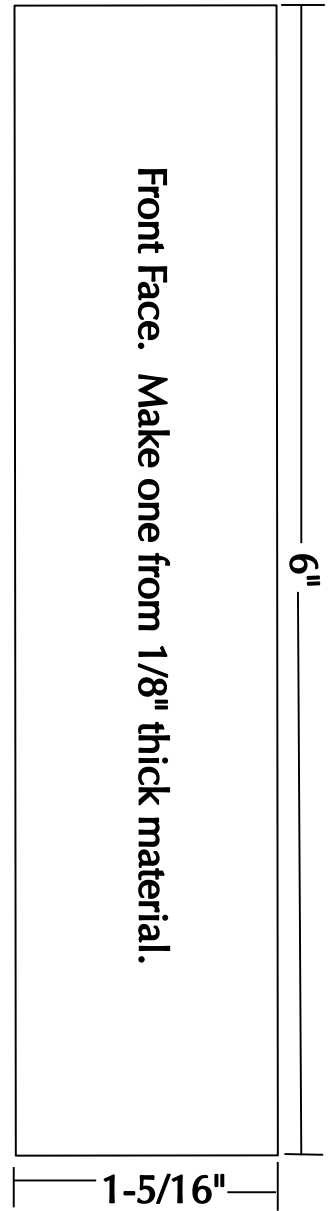
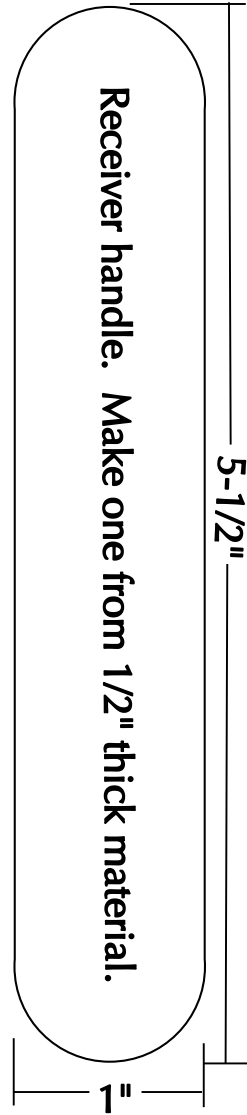
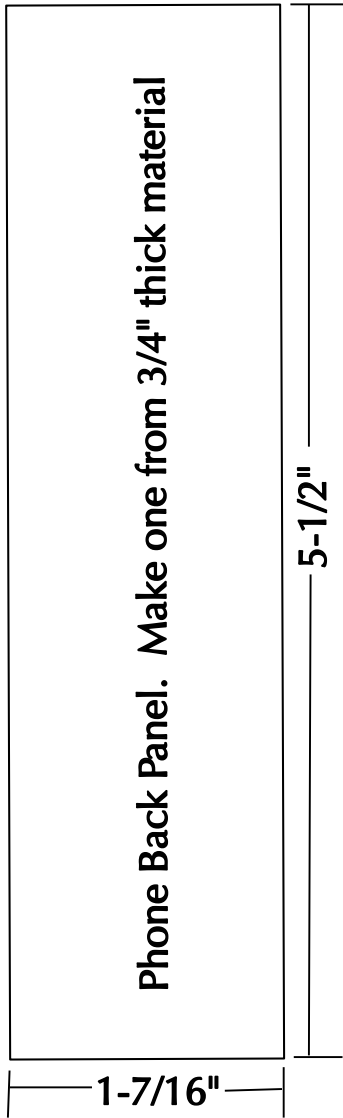
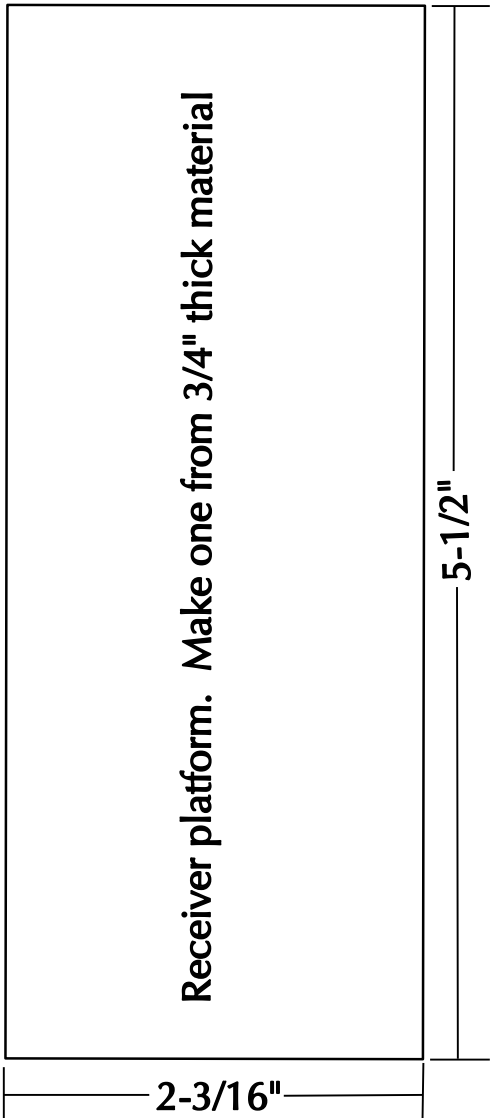

**Acutabove Woodworkings**  
**Classic Phone Toy**  
[www.acutabovewoodworkings.com](http://www.acutabovewoodworkings.com)

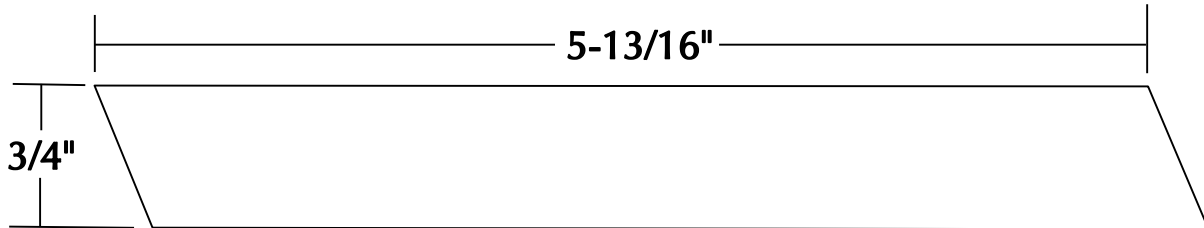

**Phone Top Panel. Make one from  $3/4"$  thick material.  
Ends cut at  $13^*$  angle.**

**Phone's bottom panel will be cut from  $3/4"$  thick material. Cut one panel  $7-1/4" \times 5-1/2"$ . Use a block plane to taper the top front edge to fit below the top panel of the phone. (piece not shown on pattern)**